



**Universiteit  
Leiden**  
The Netherlands

## **An egg is always an adventure: anthropogenic impacts on *Culex pipiens* population dynamics**

Boerlijst, S.P.

### **Citation**

Boerlijst, S. P. (2025, March 18). *An egg is always an adventure: anthropogenic impacts on *Culex pipiens* population dynamics*. Retrieved from <https://hdl.handle.net/1887/4198436>

Version: Publisher's Version

License: [Licence agreement concerning inclusion of doctoral thesis in the Institutional Repository of the University of Leiden](#)

Downloaded from: <https://hdl.handle.net/1887/4198436>

**Note:** To cite this publication please use the final published version (if applicable).

# **AN EGG IS ALWAYS AN ADVENTURE**

Anthropogenic impacts on *Culex pipiens* population dynamics

SAM P. BOERLIJST

© **2024** Sam Philip Boerlijst 2024

An Egg is Always An Adventure © **2024** by Sam Philip Boerlijst is licensed under Attribution 4.0 International. To view a copy of this license, visit <https://creativecommons.org/licenses/by/4.0/>

**Ph.D. Thesis**, Leiden University, the Netherlands

The research described in this thesis was conducted at the Institute of Environmental Sciences (CML), Leiden University, the Netherlands

An electronic copy of this thesis can be found at <https://scholarlypublications.universiteitleiden.nl>

**ISBN** 978-90-5191-213-5

**Cover design and Layout** Sam P. Boerlijst

**Photos and illustrations** Sam P. Boerlijst

**Printed by** Ipskamp printing

# **AN EGG IS ALWAYS AN ADVENTURE**

Anthropogenic impacts on *Culex pipiens* population dynamics

Proefschrift

ter verkrijging van  
de graad van doctor aan de Universiteit Leiden,  
op gezag van rector magnificus prof.dr.ir. H. Bijl,  
volgens besluit van het college van promoties  
te verdedigen op dinsdag 18 maart 2025  
klokke 16:00 uur  
door

Sam Philip Boerlijst  
geboren te De Haan, België  
in 1995

**Promotor:**

Prof dr. ir. P.M. van Bodegom

**Co-promotores:**

Dr. M.J.J. Schrama

Dr. E. Boelee (Deltares)

**Promotiecomissie:**

Prof. dr. ing. M.G. Vijver

Prof. dr. K. Biesmeijer (Naturalis Biodiversity Center, Leiden University)

Prof. dr. F. Bartumeus Ferré (University Pompeu Fabra)

Prof. dr. Q.A. ten Bosch (Wageningen University & Research)

Dr. M. Braks (RIVM, Leiden University)

This publication is part of the project 'Preparing for vector-borne virus outbreaks in a changing world: a One Health Approach' (NWA.1160.1S.210) which is (partly) financed by the Dutch Research Council (NWO).

*“That which appears to be chaotic in nature  
is only a more complex kind of order.”*

- Gary Snyder



# Contents

		<b>Page</b>
Chapter 1	General introduction	1
Chapter 2	Biting the hand that feeds: anthropogenic drivers interactively make mosquitoes thrive	21
Chapter 3	In the heat of the moment: including realistic thermal fluctuations using an open-source thermoregulator results in dramatically altered key population parameters	53
Chapter 4	Taking it with a grain of salt: tolerance to increasing salinization in <i>Culex pipiens</i> (Diptera: Culicidae) across a low-lying delta	87
Chapter 5	Clashing in murky waters: on amphibian mosquito suppression	115
Chapter 6	Discussion	147
	References	163
	Summary	205
	Samenvatting	211
	Acknowledgements	217
	Curriculum vitae and publications	223



Graphical illustration of an adult female house mosquito in mid-flight.

## Chapter 1

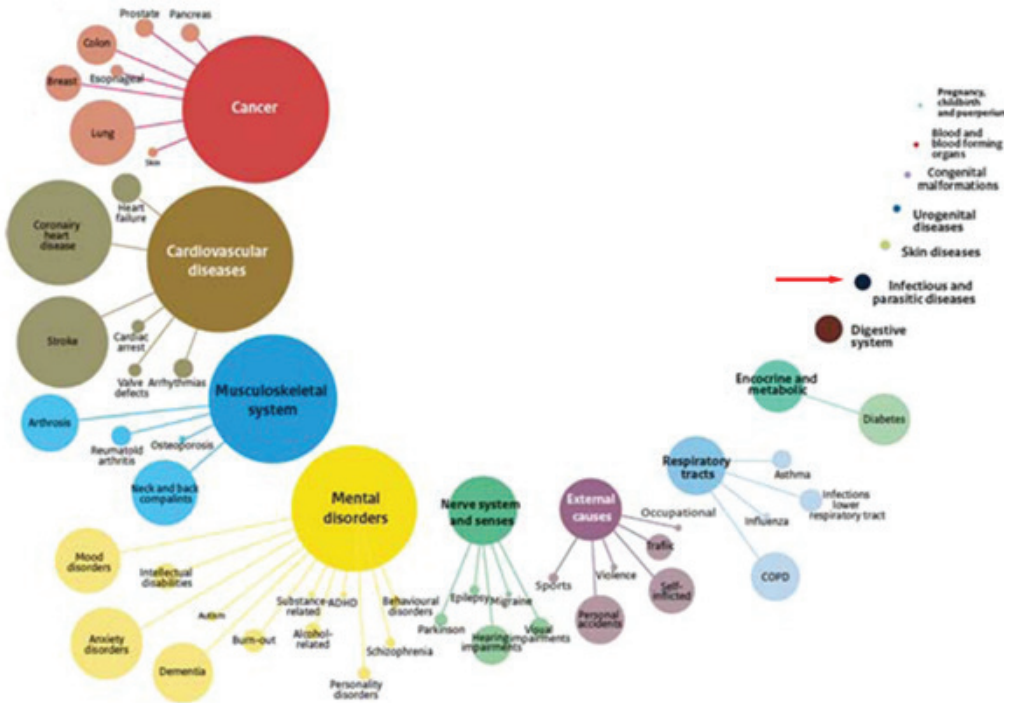
### **General introduction**

## 1.1 Infectious disease burden in Europe

In the past century the patterns of human trade and travel, climate conditions, and land and water usage, have undergone significant change (Lambin & Meyfroidt, 2011). The joint effect of these changes have caused rapid transmission of diseases to become more prevalent (Lühken et al., 2023), highlighting the interconnectedness of human well-being with earth's natural systems. The need for collaborative efforts and shared resources is therefore increasingly emphasized, to mitigate the spread of diseases, guarantee access to essential healthcare services, and promote equitable health outcomes worldwide, a concept known as planetary health (Whitmee et al., 2015).

Infectious diseases constitute a key challenge to planetary health (Myers, 2017), encompassing a wide array of pathogens including bacteria, viruses, and parasites. Among the various mechanisms through which these pathogens spread, arthropods play a crucial role as *vector\** (WHO, 2014). Mosquito-borne pathogens, in particular, contribute significantly to the global disease burden, with a majority of arthropod-borne disease burden attributed to them (WHO, 2014).

Despite the interconnectedness facilitated by globalization and the changing environmental conditions, the current morbidity of infectious diseases, at least in Europe is still relatively low (Charalampous et al., 2023; Hilderink et al., 2020; Figure 1.1 exemplifying this for the Netherlands), especially when compared to tropical regions, where such diseases (e.g. Chikungunya, Dengue, malaria, West Nile fever and Zika) are increasingly prevalent (Global Burden of Disease Pediatrics Collaboration, 2016; Roser et al., 2021). These figures are in stark contrast to historical figures, e.g. in the 19th century, when Europe was more susceptible to outbreaks of infectious diseases than recently, with circulation of malaria (Boualam et al., 2021; Green, 2018), Cholera, typhoid and tuberculosis (Griffioen, 2024; Peters et al., 2021; Wolleswinkel-van den Bosch et al., 1997). Understanding whether the abovementioned global changes may eventually lead to the return of omnipresent vector borne diseases (hereafter VBD) in Europe as a key challenge, may aid the public-health infrastructure to prepare for potential re-emergence. For this, identifying changes in the *pathogenic landscape\**, related to the disease ecology, is pivotal (Gratz, 1999).



**Figure 1.1** Burden of Disease in the Netherlands in 2015, for 17 chapters of the international classification of diseases and associated health conditions. The size of the bubbles represents the burden of disease, expressed in disability-adjusted life years. Burden of disease for the combined infectious diseases is highlighted with a red arrow (Adapted from Hilderink et al., 2020).

## 1.2 Pathogenic landscapes

The pathogenic landscape – i.e., the interplay between environment, people, vectors, and animal *hosts*\* – is subject to diverse natural processes that operate along spatial and temporal axes. Spatially, infectious diseases are influenced by factors such as land use types, vector habitat preferences, wildlife habitats, and ultimately human interactions with vectors, all of which contribute to the geographic distribution and prevalence of diseases (Abella-Medrano et al., 2015; Day, 2016; Ferraguti et al., 2023). Temporally, disease dynamics exhibit variations driven by climate-induced seasonal changes, fluctuations in vector activity, patterns of host migration and movement, and global travel, impacting the likelihood of disease transmission and outbreak occurrence (Beck-Johnson, Nelson, Paaijmans, Read, & Bjørnstad, 2017; Gratz, 1999; Tatem et al., 2012).

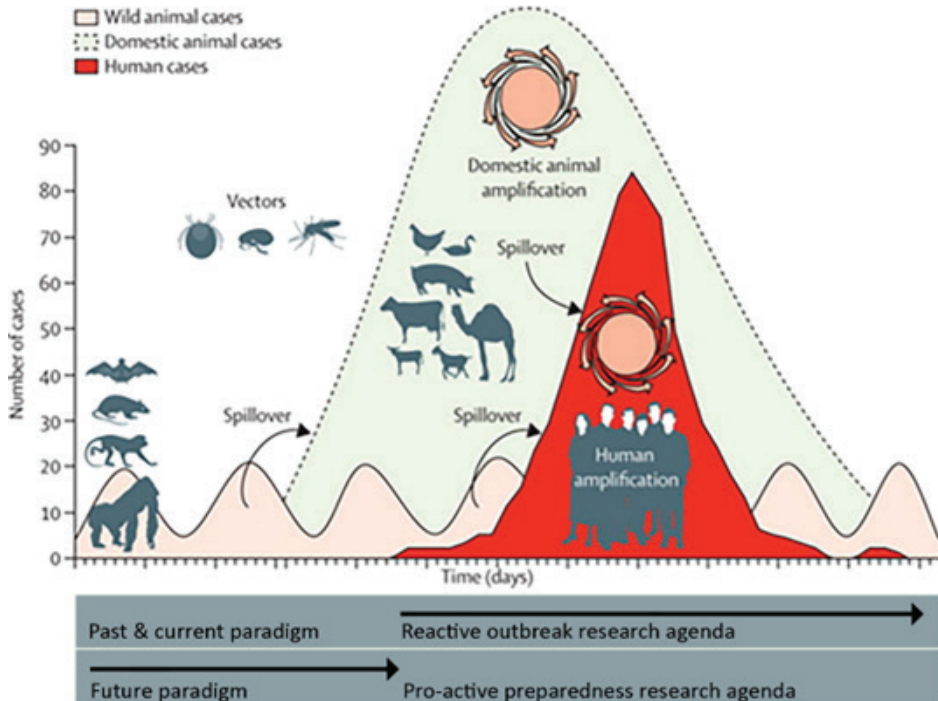
## Chapter 1

---

There is a discernible trend of increasing incidence and spread of pathogen outbreaks over time, extending beyond natural oscillations (Lühken et al., 2023), suggesting that anthropogenic influences such as human activities and environmental changes underly these trends. These activities directly affect pathogens via encounter rates with vectors, and indirectly affect pathogens via climate change, land use change, and water management, thereby impacting habitat quantity and quality for *reservoir species\**, vector species, and human populations (see section 1.4).

Changes in the pathogenic landscape may impact, and be impacted by, shifts in the distributions and abundances of reservoir species, vector species, and human populations, influencing disease transmission and outbreak potential (Lambin et al., 2010). Traditional assessments and interventions for infectious diseases often operate in separate disciplines (i.e. ecology, entomology and medical sciences) and measures tend to be reactive, initiated only after disease spillover into human populations has occurred, thereby often limiting their effectiveness (Laydon et al., 2023; Sacco et al., 2023).

Proactive measures that anticipate and mitigate outbreaks prior to occurrence might lead to more effective responses to disease outbreaks (Laydon et al., 2023; Meckawy et al., 2022; Sacco et al., 2023; Figure 1.2). By addressing the underlying factors driving changes in the pathogenic landscape, proactive measures can help prevent the emergence and spread of infectious diseases. A holistic assessment, integrating insights from various disciplines, is necessary to understand and manage infectious diseases effectively. A *One Health\** approach offers a framework for comprehensive assessment and intervention, considering the complex interactions within the pathogenic landscape, to improve disease management in a changing world.



**Figure 1.2** Transmission of infection and amplification in people (bright red) occurs after a pathogen from wild animals (pink) moves into reservoir species (e.g., livestock) to cause an outbreak (light green) that amplifies the capacity for pathogen transmission to people. Proactive research may provide early warning indicators for changes for risk assessment and fitting interventions to limit spillover to people. Spillover arrows show cross-species transmission. (Adapted from Karesh et al., 2012).

### 1.3 A one health approach towards preparedness

Early detection of infectious disease outbreaks is vital for timely and proactive response and effective interventions. Monitoring of early warning indicators, including changes in vector populations, wildlife behavior, and environmental conditions, can provide crucial insights into potential disease emergence (Becker et al., 2019; Childs et al., 2019; Montgomery et al., 2017). Effective interventions, however, require a comprehensive understanding of the factors that shape the pathogenic landscape which includes intricate interactions between different players, including hosts, vectors, and environmental factors. Information on the relative importance of these factors is currently, however, not available. Acquiring this information requires interdisciplinary expertise, as interventions can then be tailored to target specific vulnerabilities within the pathogenic landscape.

## Chapter 1

---

To address the interdisciplinary challenges regarding this approach to study infectious disease, the One Health PACT consortium was assembled in 2020 ([www.onehealthpact.org](http://www.onehealthpact.org)), a partnership between (Dutch) national and international partners, to address shared health challenges collectively. The project is a collaboration of experts ranging from ecological and climate modelling to medical entomology, virology and public health, and aims to determine large-scale changes (tipping points) in disease transmission, which could lead to outbreaks of VBD. To this end, the project i) generates data on the dynamics of humans, vectors, and reservoirs, ii) characterizes arbovirus infections, iii) models the complex interplay that drive arbovirus dynamics, and iv) develops interventions and surveillance strategies. This thesis plays a central role in this endeavor by investigating the ramifications of the effects of land use and change therein on mosquito vector populations.

By investigating how anthropogenic activities impact ecosystem dynamics, proactive measures, including a surveillance network, can be developed for timely interventions to minimize disease risks. Identifying factors that limit disease outbreaks, such as vector presence and abundance, further informs these interventions by identifying and predicting potential risk sites. Vector ecology plays a crucial role in this process, as vector presence and abundance directly influence disease dynamics (Kolimenakis et al., 2021), and since effective interventions often target mosquitoes (Aryaprema et al., 2023; Benelli, 2015; Benelli et al., 2016; Floore, 2006; Pilger et al., 2010). Thus, integrating insights from ecological studies on critical facets of disease transmission, including vector dynamics, enables a comprehensive approach to mitigating the impacts of infectious diseases as a result of anthropogenic changes in the environment.

### 1.4 Mosquito ecology in a changing world

Anthropogenic impacts on disease transmission can occur in a number of ways 1) through changes in land use, 2) through changes in water management, 3) through changes in climatic conditions, and joined effects of these on overall biodiversity. These factors are especially relevant to the transmission of mosquito borne diseases, which are responsible for a major part of vector borne disease incidences (van den Berg & Schaffner, 2016; WHO, 2017).

Vector borne diseases may be affected by fragmentation of ecosystems resulting from the conversion of natural habitats, e.g. for agriculture and urbanization (Ferraguti et al., 2016, 2023). Deforestation, in particular, disturbs wildlife habitats, leading to increased human-wildlife interactions and observed subsequent spillover of pathogens (Gottwalt, 2013; Gratz, 1999; Ortiz et al., 2022). Changes in land use can modify vector habitat suitability, promoting pioneer species, such as disease-transmitting mosquitoes (Abella-Medrano et al., 2015; Steiger et al., 2012). Agricultural practices, including irrigation and deforestation, can create nutrient rich breeding grounds for disease vectoring mosquitoes, amplifying

disease transmission cycles (Buxton et al., 2020; Rasmussen, 1998; Waters et al., 2021). Moreover, urbanization concentrates human populations, facilitating the rapid spread of infectious diseases in densely populated areas (Romeo-Aznar et al., 2018).

Water management, and changes therein, may impact pathogen transmission as well (Akanda et al., 2020). Changes in water flow patterns, for instance, can create favorable conditions for mosquito breeding, leading to increased transmission of VBD (Elias et al., 2022). Poor sanitation and wastewater management further exacerbate the risk of disease transmission by creating high quality breeding habitats (Lines et al., 1994).

Climate change-induced alterations in precipitation patterns and water availability can further influence disease dynamics by affecting water permeability of soil, thereby creating mosquito breeding sites (Caplan et al., 2019; Krol et al., 2023). Rising temperatures can expand the geographic range of disease vectors, allowing them to thrive in previously inhospitable areas (Kraemer et al., 2015; Lühken et al., 2023; Medlock et al., 2012). Ongoing salinization on the other hand may limit their geographic range (Jardine et al., 2008; Roberts & Irving-Bell, 1997). Finally, climate change can disrupt seasonal patterns, prolonging the transmission seasons of VBD (Romeo-Aznar et al., 2018) and increasing the frequency and intensity of extreme weather events (Stott, 2016), which can facilitate disease outbreaks and exacerbate health risks (Esser et al., 2019). Although all these facets can impact mosquito ecology, it is currently unknown what their relative importance is, as this is highly context dependent. Their relevance, particularly in the Dutch landscape, should therefore be more closely examined.

### 1.5 Shifting mosquito habitat dynamics in the pathogenic landscape

Understanding mosquito ecology is crucial to identify how anthropogenic influences impact mosquito population dynamics and behavior, and thereby associated disease transmission and eventually the pathogenic landscape. The quality and availability of larval habitats play a critical role in shaping mosquito populations (Beck-Johnson et al., 2013; Radrova et al., 2013; Rejmánková, Grieco, Achee, & Roberts, 2013). Evaluating *pressures\** from environmental variation and human impacts (Lambin et al., 2001; Steiger et al., 2011) on habitat quality and availability therefore provides a framework for understanding the impacts on mosquito *oviposition\** behavior and *life-history traits\**.

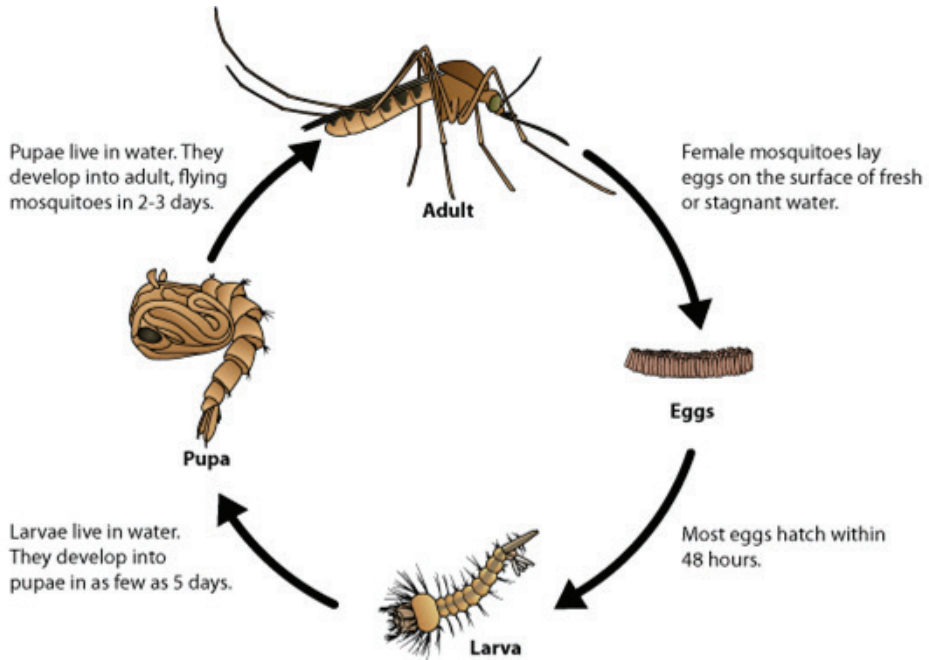
Any one pressure may have multiple (interconnected) influences. For instance, habitat quality may directly shape populations, by influencing factors such as development rate, mortality and sex ratio (Beck-Johnson et al., 2013; Couret & Benedict, 2014; Knight et al., 2004). Additionally, habitat quality may alter ovipositioning behavior, thereby impacting whether a larval habitat gets colonized at all. Namely, changes in pressures, such as food availability, chemical pollution and density of other mosquito larvae, may alter cues that inform decision making on where and where not to put one's eggs (M. Akiner & Eksi,

2015; Dhileepan, 1997; J. Li et al., 2009; Mwingira et al., 2020; Rejmánková, Grieco, Achee, Roberts, et al., 2013). The identified *stressors\** therefore provide insight in the dynamics and productivity of these habitats and can thus be used to model and predict adult abundance. This in turn can be used to inform interventions and thereby limit disease risk. Although most current literature focuses on a limited set of single stressors (Alcalay et al., 2018), more and more studies demonstrate the importance of synergetic and antagonistic effects on population dynamics (Courret & Benedict, 2014; Krol et al., 2019; Meyabeme Elono et al., 2018; Schrama et al., 2018; Sukiato et al., 2019), highlighting the need for a more holistic approach.

### 1.6 Quantifying effects of stressors on mosquito population dynamics

Mosquito population dynamics are characterized by several parameters dictating population size and structure, including development rate, survival rate, sex ratio, and oviposition behavior. None of these parameters occur in a vacuum and as a result they may impact each other. For instance, high conspecific densities may speed up development (Alcalay et al., 2018) and ovipositioning behavior may affect larval survival and population growth (Ikeshoji, 1966). These parameters and their interactions determine the size and distribution of mosquito populations, in turn influencing transmission of mosquito-borne diseases.

Development rate, defined as the duration it takes for mosquitoes to progress from egg to adult (Figure 1.3), is dependent on resource availability and expenditure (Beketov & Liess, 2007; Huxley et al., 2021; Rivero et al., 2011; Ukubuiwe et al., 2017), with potentially life stage specific effects (Clark et al., 2004). Generally limited by the amount of energy allocated for growth, development times may adaptively increase as maintenance and repair processes to maintain homeostasis become increasingly necessary as a result of stress. This stress can be due to various factors impacting metabolic rate (such as food availability and temperature) or toxicity (e.g., water quality, salinization and pesticides). Under exposure to accumulative stressors, however, there may be selection for early maturation (Alcalay et al., 2018; Jourdan et al., 2016). By entering metamorphosis with fewer resources, the individual then increases its chances to emerge, at the cost of decreased longevity and fecundity (Alcalay et al., 2018; Reisen et al., 1984).



**Figure 1.3** Life stages of *Culex* species mosquitoes (Adapted from CDC, 2022)

Responses in development rate are relatively well known for single stressors like temperature, eutrophication, pesticides and conspecific density under static conditions (Agnew et al., 2000; Ciota et al., 2014; Couret & Benedict, 2014; Kiarie-Makara et al., 2015), but increasing evidence suggests that including natural fluctuations, particularly for temperature, may exacerbate the effects of a stressor (Beck-Johnson, Nelson, Paaijmans, Read, Thomas, et al., 2017; Colinet et al., 2015; Hagstrum & Milliken, 1991). While including natural oscillations may yield more accurate and relevant results, it is underrepresented, likely as small-scale and affordable experimental systems were until recently unavailable (Hagstrum & Milliken, 1991; Hermann et al., 2022). This highlights the need for an inexpensive fieldable temperature control system and validation comparing commonly used temperature regimes for mosquitoes.

The impacts of the environmental variable salinization are less well known, but nevertheless of increasing relevance (Lassiter, 2021). While numerous studies have examined mortality associated with salinity (Kengne et al., 2019; Thamer & Abdulsamad, 2005; Van Schie et al., 2009), and occasionally sublethal effects such as development rates (Schuler & Relyea, 2018), little is known on sublethal effects for species considered particularly vulnerable to salinity, like *Cx. pipiens* (Kengne et al., 2019). This lack of understanding is especially true for interactive stressors like temperature, which could modify ion uptake via increased metabolism. Information on the impacts of salinity is even scarcer in regions

## Chapter 1

---

experiencing ongoing salinization, such as the Netherlands (Oude Essink et al., 2010; Pauw et al., 2012). Gradual exposure near the coast in such regions may have caused adaptations (Ramasamy & Surendran, 2012), possibly developing more rapidly than in their predators, due to differences in generation time, which may cause alleviation in predation pressure (Schuler & Relyea, 2018). Understanding the impacts of salinization is therefore crucial, as this may inform us whether to regard areas with ongoing salinization as potential mosquito hotspots.

Mosquito survival, referring to the percentage of individuals that develop from one life stage to the next, is impacted similarly, through effects of resource availability (and lack thereof) and expenditure. For instance, minor stress may be overcome if sufficient resources are available (Huxley et al., 2021). If limited resources are available, survival may be prioritized over reproduction, as described above. As a result, combined and synergistic stressor effects may cause increased mortality compared to single stressor experiments (Mottram et al., 1994). One such synergistic interaction may involve larval competition (Agnew et al., 2000), translating to availability of food resources per capita. This interaction is known to depend on larval density (Alto et al., 2012), larval habitat size (Wynn & Paradise, 2001) and microbial abundance (Peck & Walton, 2006). A potential link with temperature exists via bacterial production and larval competition (Adams et al., 2010; Ezeakacha & Yee, 2019), but has not been explored in this context. These impacts on mortality may be sex-specific, thereby causing shifts in sex ratio. Female mosquitoes on average take longer to emerge as a result of their larger body size (Loetti et al., 2011; Virginio et al., 2015). As a result, they may be exposed to (accumulative) stress for longer periods than male individuals, which may cause increased mortality resulting in a skewed sex ratio (Alcalay et al., 2018).

There are many ways in which individuals may deal with stress, such as adaptations in morphology and behavior, or by avoiding high-stress locations altogether. Egg-laying behavior actively affects the impacts of stressors to which the eggs, larvae and pupae are subjected. For instance, gravid females provide their brood with favorable conditions such as food availability and lowered competition (Bruno & Laurence, 1979; Hasselschwert & Rockett, 1988; Mwingira et al., 2020; Silberbush et al., 2014). As a result, conditions under which mosquito larvae theoretically could be present, may not be colonized (M. M. Akiner & Eksi, 2015; Day, 2016; Ikeshoji & Mulla, 1970). It is therefore essential to determine both the effects of single stressors as well as antagonistic and synergetic effects on egg-laying behavior to contextualize the results of the experiments of *systemic\** and *external drivers\**.

## 1.7 Interventions

Interventions to mitigate mosquito-borne disease transmission primarily focus on mosquito control (Aryaprema et al., 2023; Pilger et al., 2010). Among these interventions, a substantial proportion concentrates on the control of mosquito larvae, as immature stages are confined in relatively high densities in small habitats and allow for increased efficacy (Becker et al., 2013). Such interventions historically often involved the use of chemicals like biocides (Nazni et al., 2005; Rochlin et al., 2016). More recently, use of toxic secondary metabolites from microorganisms such as Bti has become prevalent (Kroeger et al., 2013; Poopathi & Abidha, 2010; Setha et al., 2007). However, these chemical methods are short-term solutions, leading to resistance (Hamdan et al., 2005; Li et al., 2002) and creating a pesticide treadmill. As competing species are often impacted similarly, chemical control may result in rapid recolonization (Meyabeme Elono et al., 2018) and overcompensation (Neale & Juliano, 2019) by mosquitoes and subsequent ecological imbalances (Allgeier et al., 2019; Brühl et al., 2020; Meyabeme Elono et al., 2018), potentially posing risks to conservation areas. This combined with the limited information on food-web effects (Brühl et al., 2020), and the subsequent unknown fate of the substances, makes its use risky, especially in conservation areas. As a result, development of alternative interventions is increasingly considered.

In recent years, proactive measures have gained considerable attention as alternatives to traditional larvicides. Notably, natural control – i.e., the release or facilitation of predator species – has emerged as a promising alternative (Benelli et al., 2016). Many mosquito breeding sites, however, especially those in urban and peri-urban areas, lack natural predators. Facilitating predatory organisms in these breeding sites therefore presents an environmentally sustainable, long-term and potentially effective means of mosquito control. This method deters egg-laying (Rubbo et al., 2011; Sougué et al., 2021) and limits immature survival whilst lowering growth rates, fecundity and delaying reproduction (S. Fischer et al., 2012; Lundkvist et al., 2003; Schrama et al., 2018). Additionally, stressful conditions – including predator presence – promote a more heterogeneous mix of developmental stages, as a result of different growth strategies among the mosquito larvae (S. Fischer et al., 2012; Knight et al., 2004), which could enable cannibalistic behavior (El Husseiny et al., 2018; Koenraadt & Takken, 2003).

The potential predator species for mosquito larval control encompass a diverse array of organisms, including aquatic beetles, true bugs, amphibians, and fishes (Covaciu-Marcov, 2010; DuRant & Hopkins, 2008; Fischer et al., 2012; Lundkvist et al., 2003; Saha et al., 2010; Saleeza et al., 2014). These predators exhibit species-specific degrees of effectiveness in controlling mosquito larvae, depending on factors such as habitat type, mosquito species, and predator-prey interactions. Current information on predator efficiency is, however, mainly limited to groups of invertebrate species (Benelli, 2015; Lacey & Orr, 1994; McDonald & Buchanan, 1981), while amphibians are hypothesized to be far more efficient (DuRant & Hopkins, 2008). As such, despite the growing interest in employing

natural predators for mosquito control, a critical gap exists in our understanding of which species are most suitable for this purpose.

Additionally, there is a scarce information indicating interactions between predation and the environment (Krol et al., 2019; Schrama et al., 2018). Murky – nutrient-rich – waters affect larval mosquito feeding behavior (Dadd, 1975; Merritt et al., 1992), and may therefore impact predator encounter rates. Eutrophication's impact on predators is uncertain (Schmutzer et al., 2008), potentially affecting their oxygen acquisition (Coffin et al., 2021) and hunting efficiency due to increased anti-predator behavior (Tuno et al., 2004) and reduced vision-based hunting (Abrahams & Kattenfeld, 1997), increasing ways for the prey to seek shelter. This highlights the need for a comparison of amphibian and invertebrate predator groups, and an assessment of predator effectiveness across the eutrophic range.

## 1.8 Aims of this thesis

The primary goal of this thesis is to identify the key drivers of *Culex pipiens* population dynamics in response to anthropogenic drivers (objective f). To gain a comprehensive understanding of how the drivers shape *Culex pipiens* its population dynamics, this thesis will assess the main systemic and external pressures (objective a and d) of selected stressors, their interactions, and how they interact with the life-history traits and egg laying behavior (objective e; Figure 1.4). Additionally, this thesis will assess a potential adaptation to ongoing coastal salinization (objective c) and evaluate the impacts of temperature fluctuations (objective b), to bring these results into their ecological context.

To address these objectives, the current thesis will focus on *Culex pipiens* s.l.. This species complex, more commonly referred to as the house mosquito, is a cosmopolitan assemblage consisting of the species *Culex australicus*, *Culex globocoxitus*, *Culex pipiens* and *Culex quinquefasciatus*. *Culex pipiens* s.l. is the most abundant mosquito species assemblage in the Netherlands, (Ibanez-Justicia et al., 2015) and locally consists of *Cx. pipiens pipiens*, *Cx. pipiens molestus* and *Cx. torrentium*. This thesis will treat this assemblage as a whole, as the complex is extremely tedious to separate these three species by morphological and molecular methods (Harbach, 2012). The species can hibernate and is therefore frequently found during winter (Becker et al., 2013; Cianci et al., 2015). It has a wide tolerance for temperature and eutrophication levels and is known to occupy almost every kind of water source, making it a common nuisance in urban environments (Becker et al., 2013).

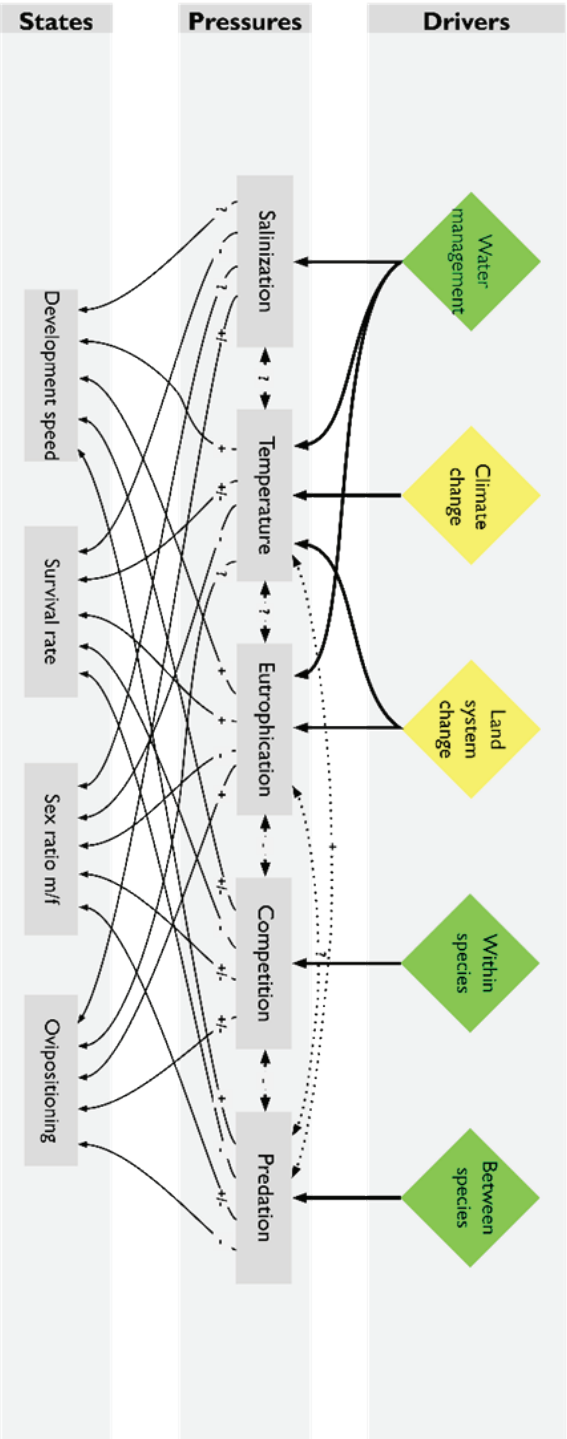
*Culex* as a genus represents the predominant vectors of West Nile virus (WNV), of which the *Culex pipiens* assemblage is the most widespread (Harbach, 2012). Wild populations of the common house mosquito have also been confirmed to transmit avian malaria, Batai, Sindbis and Usutu (Ibanez-Justicia et al., 2015). An additional aptitude for

transmission of *Dirofilaria immitis*, Tahyna and Zika was verified in lab experiments (Guo et al., 2016; Ibanez-Justicia et al., 2015). Due to its high abundance, wide range and its aptitude for transmission of a wide variety of diseases, it is important to understand the population dynamics of the species. Even more so considering the recent findings of WNV in the north-west of Europe, including the United Kingdom and the Netherlands (Folly et al., 2020; Vlaskamp et al., 2020). Both for assessment of vector competence under different scenarios and as a competitor with invasive species.

This thesis examines the main external and systemic drivers of population parameters for *Culex pipiens* (Diptera: *Culicidae*), the common house mosquito in a mesocosm set-up. For this, the current thesis focuses on the interactions between and within i) systemic pressures impacting larval habitat, such as climate variables and nutrient availability and ii) external pressures impacting *Cx. pipiens* larvae, such as predation and density dependence.

Specifically, the work in this thesis has the following objectives:

- a. Assess the effects of salinization, temperature, eutrophication, larval density and relevant interactions on mosquito populations.
- b. Develop a temperature control system to study the significance of thermal variation on mosquito development.
- c. Evaluate local adaptation of house mosquito populations to salinization along a coastal-to-inland gradient by quantifying their tolerance to varying chloride concentrations.
- d. Assess the effectiveness of common amphibian species in controlling mosquito populations.
- e. Determine the influence of selected stressors and their interactions on egg-laying behavior.
- f. Identify the main anthropogenic drivers on *Culex pipiens* population dynamics.



**Figure 1.4** Overview of systemic and external drivers on abiotic pressures and its impacts on downstream population parameters of mosquitoes. For each of the established impacts between pressures and states, it is indicated whether the association is positive (+), negative (-) or both (+/-). Question marks indicate hypothesized links and interactions of pressures where further work is needed.

## 1.9 Thesis outline

**Chapter 2** investigates the impact of anthropogenic pressures on mosquito populations and the potential implications for the transmission of mosquito-borne diseases. Specifically, the text aims to explore the effects of salinization, temperature, and food availability on mosquito populations, as well as the interactions between these factors (objectives a and e). This chapter aims to provide a comprehensive assessment of the effects of these environmental stressors on mosquito population parameters. The presented study provides an overview of the main stressors and interactions on *Culex pipiens* population dynamics, thereby providing a basis for predictive models, prevention and mitigation strategies.

**Chapter 3** further examines the effects of temperature via the development of an inexpensive, easily reproducible, and open-source Arduino-based temperature control system that can emulate natural sinusoidal fluctuations in temperature above ambient levels (objective b). The ultimate goal is to provide a more accurate assessment of the relative importance of thermal variation on ectotherm development, which could have implications for predicting the effects of large-scale disturbances like climate change on these organisms.

**Chapter 4** evaluates whether (local) adaptation to salinization has occurred in populations of the house mosquito along a gradient from coast to inland (objective c and e). The study aims to quantify and compare the tolerance of *Cx. pipiens* populations to varying concentrations of chloride in mesocosms, ranging from freshwater to the predicted maximum inland surface water concentration of 7.5 g/L Cl<sup>-</sup> or the brackish-marine transition zone at almost half the concentration of seawater.

**Chapter 5** explores the effectiveness of various predator species in controlling mosquito populations, with a focus on the European amphibian species smooth newt and edible frog as well as the invertebrate species two-spot water beetle and backswimmer. The study aims to compare the predator competence of these species in different ecological contexts, including levels of turbidity, and to determine whether there is a sex-specificity in predator competence among the amphibian species (objectives d and e). Additionally, the study aims to examine the effect of predator presence on mosquito oviposition behavior and to validate predatory behavior on other mosquito genera. In doing so this chapter aims to provide insights into the potential of natural predators as a means of controlling

## Chapter 1

---

mosquito populations, particularly in light of concerns about the effectiveness and environmental impact of chemical interventions.

**Chapter 6** discusses the obtained insights into main anthropogenic effects on *Culex pipiens* populations, examining their effects and interactions across ecological scales (objective f). It is further demonstrated how this understanding may enhance ecological realism in experimental vector ecology. A perspective is then provided on how these insights into the population dynamics of *Culex pipiens* contribute to epidemiological preparedness, via the processes of surveillance, risk-mapping and modelling and landscape design.

---

**Textbox 1. Terminology surrounding vector ecology**

Consistent terminology helps to avoid ambiguity in scientific and regulatory discourse. Definitions of terms surrounding vector ecology and anthropogenic pressures as adhered to in this thesis are provided below.

**Anthropogenic pressures:** Human-induced changes or disturbances to natural ecosystems.

**Community composition:** The relative abundance and diversity of species in a particular community.

**Driver:** refers to a process that directly or indirectly influences an ecosystem or population. Drivers may include climate change, land use changes, or freshwater use. These drivers can have both direct and indirect effects on mosquito populations, such as affecting food sources or inducing mortality.

**External driver:** biotic influences on an ecosystem or population as a result of interactions between and within species, such as predation, density dependence, and competition.

**Host:** an organism that harbors and provides a habitat for a pathogen, allowing it to live, grow, and potentially cause harm or disease within the host organism. Hosts can be humans, animals, plants, or even microorganisms such as bacteria or fungi.

**Infectious diseases:** illnesses caused by pathogenic microorganisms, such as bacteria, viruses, fungi, or parasites, which can spread directly or indirectly from one person to another, typically through contact with contaminated surfaces, bodily fluids, respiratory droplets, or vector species.

**Life-history traits:** characteristics of an organism that influence its survival and reproduction, encompassing traits such as age at maturity, reproductive output, and lifespan.

**Mesocosm:** a controlled environment used to simulate natural conditions. Mesocosms are used in ecological research to study the effects of various factors, such as temperature, salinity, or pollution, on populations or species communities. Mesocosms can vary in size and complexity, but they typically consist of a container or enclosure that contains a sample of an ecosystem, such as a pond or a forest, along with (a selection of) the organisms that inhabit it. Conditions within the mesocosm, such as by changing the temperature or adding pollutants, may be manipulated to observe how the species or population respond. Mesocosms allow us to conduct experiments in a controlled setting while still capturing some of the complexity of natural ecosystems, making them a valuable tool for studying ecological processes.

**Natural control:** The use of natural predators or other biological agents to control pest populations.

**One Health:** a collaborative interdisciplinary framework embracing the interconnectedness between human, animal and environmental health by recognizing that addressing health challenges requires an effort across multiple disciplines.

**Oviposition:** the process of laying eggs.

**Pathogenic landscape:** environment concerning the presence, distribution, and characteristics of pathogens (disease-causing microorganisms) within a particular geographical area or population.

**Population parameters:** measurable characteristics or attributes of a population. These parameters provide information about the size, structure, and dynamics of a population and may include, but are not limited to, sex ratio, mortality rate, growth rate and density.

**Pressure:** refers to an external forces or process that may affect ecosystems or populations. These pressures can be natural, such as soil type, or anthropogenic, meaning they are caused by human activities like land use practices. These pressures can shape ecosystems and influence the abundance and composition of species.

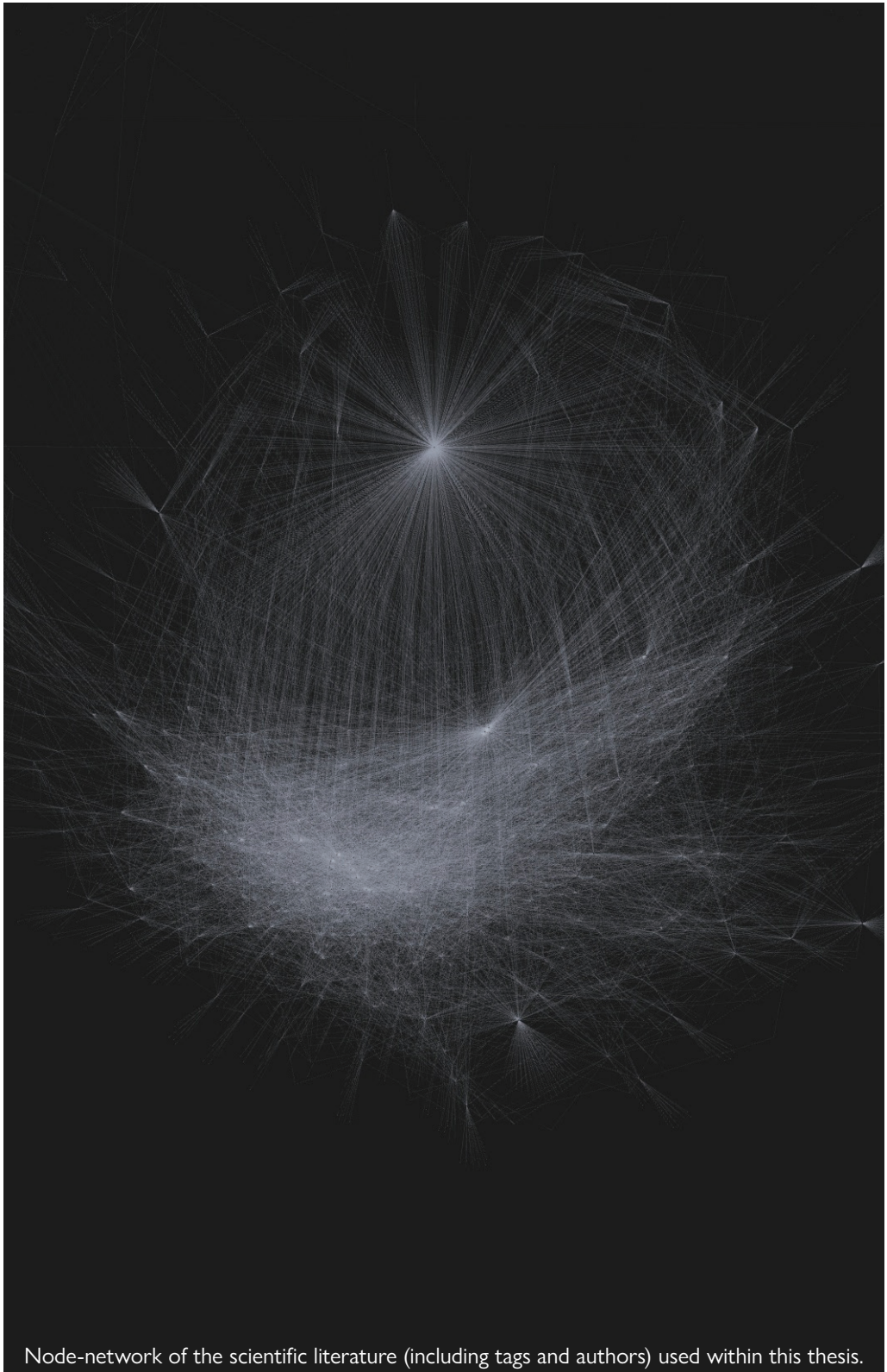
**Reservoir:** a population of organisms in which a pathogen reproduces, often without causing disease for the host. Reservoir species play a crucial role in the lifecycle of certain infectious agents by serving as a source of infection for other susceptible hosts, including humans. Reservoir species may actively participate in transmission to other hosts and may amplify or simply maintain the pathogen.

**Stressor:** refers to any biotic or abiotic factor that can cause stress to organisms in an ecosystem. This stress can be i) physical, such as changes in temperature, ii) biological, such as predation, or iii) chemical, such as salinization. Stressors can directly and indirectly affect various aspects of an organism's life, such as its egg-laying behavior, growth, and survival.

**Systemic driver:** anthropogenically induced influences on an ecosystem or population via for instance changes in climate, land use, and water management.

**Vector:** an organism, typically an invertebrate arthropod like a mosquito, tick, or flea, which transmits pathogens from one host to another.





Node-network of the scientific literature (including tags and authors) used within this thesis.

## Chapter 2

# **Biting the hand that feeds:** anthropogenic drivers interactively make mosquitoes thrive



*Science of The Total Environment* (2023) 858(2)  
DOI: [10.1016/j.scitotenv.2022.159716](https://doi.org/10.1016/j.scitotenv.2022.159716)

Sam P. Boerlijst, Erin S. Johnston, Anne Ummels, Louie Krol,  
Eline Boelee, Peter M. van Bodegom and Maarten Schrama

## Highlights

- 1) Impacts of interlinked anthropogenic stressors are relatively unknown.
- 2) Such stressors include land use change, freshwater pollution, and extreme weather.
- 3) Full-factorial experiments assessed stressor impacts on disease vector *Culex pipiens*.
- 4) The stressors and their interactions had major impacts on key mosquito life-history traits.
- 5) Results show important ramifications for mosquito populations and the pathogenic landscape.

## Abstract

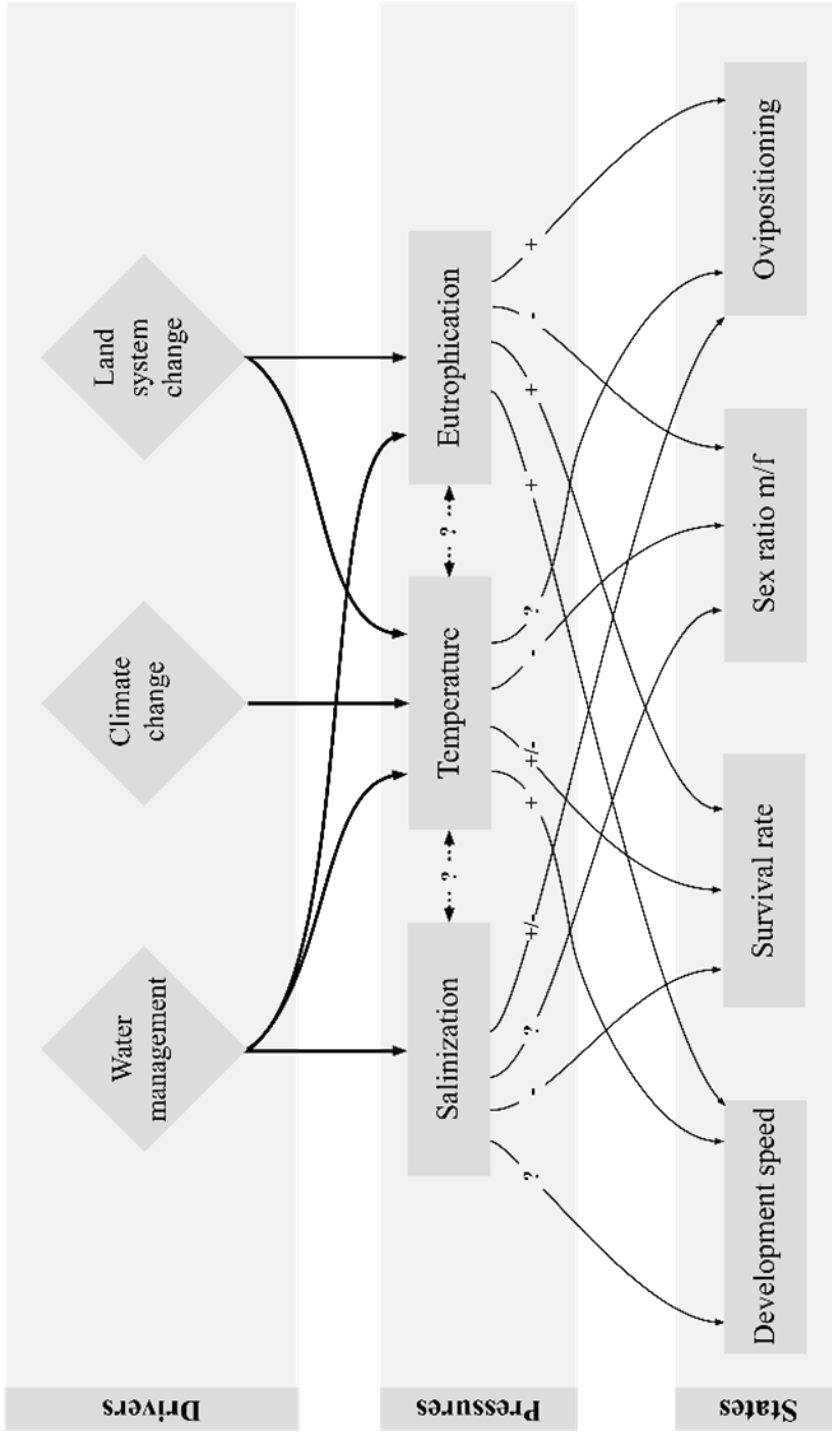
Anthropogenic stressors on the environment are increasing at unprecedented rates and include urbanization, nutrient pollution, water management, altered land use and climate change. Their effects on disease vectors are poorly understood. A series of full factorial experiments investigated how key human induced abiotic pressures, and interactions between these, affect population parameters of the cosmopolitan disease vector, *Culex pipiens s.l.* Selected pressures include eutrophication, salinity, mean temperature, and temperature fluctuation. Data were collected for each individual pressure and for potential interactions between eutrophication, salinization and temperature. All experiments assessed survival, time to pupation, time to emergence, sex-ratio and ovipositioning behavior. The results show that stressors affect vector survival, may speed up development and alter female to male ratio, although large differences between stressors exist to quite different extents. While positive effects of increasing levels of eutrophication on survival were consistent, negative effects of salinity on survival were only apparent at higher temperatures, thus indicating a strong interaction effect between salinization and temperature. Temperature had no independent effect on larval survival. Overall, increasing eutrophication and temperatures, and the fluctuations thereof, lowered development rate, time to pupation and time to emergence while increasing levels of salinity increased development time. Higher levels of eutrophication positively impacted egg-laying behavior; the reverse was found for salinity while no effects of temperature on egg-laying behavior were observed. Results suggest large and positive impacts of anthropogenically induced habitat alterations on mosquito population dynamics. Many of these effects are exacerbated by increasing temperatures and fluctuations therein. In a world where eutrophication and salinization are increasingly abundant, mosquitoes are likely important benefactors. Ultimately, this study illustrates the importance of including multiple and combined stressors in predictive models as well as in prevention and mitigation strategies, particularly because they resonate with possible, but yet underdeveloped action plans.

**Keywords:** Interactive effects, Habitat alteration, Mosquito, Planetary boundary framework, Salinization, Temperature fluctuations

## 2.1. Introduction

2 Anthropogenic pressures play a pivotal role in shaping ecosystems on a global and local scale (Foley et al., 2005; Nelson et al., 2006), and subsequently affect species abundance and composition (Barausse et al., 2011; Cecco et al., 2022; Eremeeva and Sushchev, 2005). While most insect species are declining due to anthropogenic pressures, such as urbanization, agricultural practices, water management and climate change (Hallmann et al., 2017; van der Sluijs, 2020), recent evidence shows that many mosquito species thrive under these conditions (Colón-González et al., 2021; Messina et al., 2019; Roche et al., 2015), thus showing a contrasting pattern, particularly in areas of high anthropogenic pressures (Kamdem et al., 2012; Nilsson et al., 2018; Ramasamy and Surendran, 2016; Schrama et al., 2020; Steiger et al., 2012). This suggests that human-induced environmental changes might have a positive impact on the availability of disease transmitting organisms (hereafter vectors), which might also influence the incidence of mosquito transmitted pathogens, such as protozoa and arthropod-borne viruses (arboviruses) (Franklinos et al., 2019; Kamdem et al., 2012; Neiderud, 2015).

Research on understanding impacts of human-induced changes on infectious diseases has until now focused on the large-scale influence of climatic variables such as mean temperature for mosquito occurrence and precipitation for mosquito abundance (Loetti et al., 2011; Mottram et al., 1994; Petrić et al., 2014; Reisen et al., 1984), while the effects of anthropogenic pressures that operate mainly on a local scale have been poorly addressed. Such local stressors include effects of changes in land use, freshwater use, biogeochemical flows, local temperature fluctuations, as well as the interplay between these drivers on microclimatic conditions (Rejmánková et al., 2013). While observational studies carried out at the landscape scale hint at the importance of these factors (Ferraguti et al., 2016; Krol et al., 2022; Schrama et al., 2020; Versteirt et al., 2013), a comprehensive understanding of the causal relationships between mosquito population size and structure and specific landscape features is lacking (Franklinos et al., 2019; Schrama et al., 2020). Moreover, the interactions of the different pressures, which often co-occur, have not been investigated in depth (Figure 2.1, supplementary Table 2.1). To understand the importance of these key anthropogenic pressures on mosquito population dynamics, which might lead to increased vulnerability to changes in (combinations of) environmental factors, in-depth experimental work is needed.



**Figure 2.1** Overview of anthropogenic pressures as drivers on abiotic pressures and its impacts on downstream population parameters of mosquitoes. For each of the established impacts between pressures and states, it is indicated whether the association is positive (+), negative (-) or both (+/-) (based on literature summarized in Supplementary Table 1). Question marks indicate hypothesized links and interactions of pressures where further work is needed.

Here, we experimentally explore the impact of salinization, temperature and eutrophication on mosquito populations (Figure 2.1). Freshwater use – more broadly defined as water management, thus including biogeochemical flow boundaries – mainly impacts eutrophication, temperature, and salinity by a variety of pathways, such as dredging of inland water bodies (Lohrer and Wetz, 2003; Smith and Huang, 2010), water retention (Ceccatelli et al., 2021; Modoni et al., 2013; Zhu et al., 2015) and freshwater extraction (de Louw et al., 2013; Schmork and Mercado, 1969). Land use change, in which humans transform the natural landscape impacts water bodies with respect to dissolved nutrient concentrations (potentially leading to eutrophication) and temperature via changes in sunlight in cleared areas (Franklinos et al., 2019) and albedo (Adegoke et al., 2007), respectively. Climate change, caused by greenhouse gas emissions leads to increasing mean temperatures and changes in diurnal temperature oscillations due to increasing nightly temperatures (Braganza et al., 2004).

Each of these large-scale environmental impacts can be expected to directly affect mosquito populations. Salinization, which occurs naturally in coastal areas (Don et al., 2006; Lassiter, 2021), is strengthened by climate induced sea-level rise, draining of fresh water, management of waterways and exploitation of groundwater for agriculture (Pauw et al., 2012; Ramasamy and Surendran, 2012). It is known to have species specific impacts on mosquito mortality rates (Jude et al., 2012; Kengne et al., 2019; Mottram et al., 1994) and egg laying (hereafter ovipositioning) behavior (De Brito Arduino et al., 2015; Navarro et al., 2003; Silberbush et al., 2014), but landscape wide responses to changes in salinity levels are poorly characterized. Eutrophication has previously been shown to influence development speed, survival, sex-ratio (Krol et al., 2019; Merritt et al., 1992; Reisen et al., 1984; Rejmánková et al., 2013; Schrama et al., 2018) and ovipositioning behavior (Rejmánková et al., 2013), but interactions with other stressors, e.g. larval densities of the same species (hereafter conspecific density), are not well represented.

While the effects of temperature on mosquitoes have been studied extensively, the effects of an increases in temperature fluctuations, which is expected because of climate change (Masson-Delmotte et al., 2021), are yet unknown. Temperature is known to affect mosquito development speed and mortality levels as well as sex-ratio with sex-specific effects (Loetti et al., 2011; Mottram et al., 1994; Petrić et al., 2014; Reisen et al., 1984), where increasing temperature generally leads to shortened development times and higher mortality. However, the vast majority

of experiments focusing on temperature have been performed by manipulating (continuous) mean temperatures (Ciota et al., 2014; Kiarie-Makara, Ngumbi, and Lee n.d.; Loetti et al., 2011), even though temperature fluctuations have previously been hypothesized to influence mosquito development (Alcalay et al., 2018; Couret and Benedict, 2014; Kiarie-Makara et al., 2015; Mottram et al., 1994; Spanoudis et al., 2019). As yet, its impact remains severely understudied (Alcalay et al., 2018; Beck-Johnson et al., 2017).

Aside from a comprehensive understanding of the isolated effects of the selected stressors, there is also a large potential for the influence of non-additive interactive effects (Tran et al., 2018). Indeed, a growing number of studies point to the ubiquity of interactive non-additive effects between stressors on population parameters (Agnew et al., 2000; Alcalay et al., 2018; Couret and Benedict, 2014; Schrama et al., 2018), but little is currently known about interactive effects. Interaction between eutrophication, larval density and temperature may manifest itself as changes in food intake per capita; interaction between salinization and temperature might increase energy expenditure for active osmoregulation via increased competition (Bradley, 1987; Kengne et al., 2019). The current lack of information on solitary and interactive effects of the selected stressors calls for a coherent and comprehensive assessment.

This study aims to evaluate and quantify the effects of eutrophication, salinization, temperature fluctuations including the interactions between eutrophication and conspecific density, temperature and eutrophication, and temperature and salinity on multiple mosquito population parameters in a series of mesocosm experiments. The cosmopolitan mosquito species *Culex pipiens* s.l. (hereafter denoted as *Cx. pipiens*) is used as a model species. *Cx. pipiens* is a known vector, e.g., for West Nile virus, Usutu virus, Sindbis virus, and parasites Filarioidea, Plasmodium and Hemoproteus (Bravo-Barriga et al., 2016; Gutiérrez-López et al., 2016; Hubálek, 2008; Kazlauskienė et al., 2013). It has a wide habitat tolerance ranging from clean rainwater-filled containers to strongly polluted temporal waterbodies such as ground puddles and even manure tanks (Becker et al., 2013; Rejmánková et al., 2013). Wild caught individuals were used – unless mention otherwise – without distinguishing between the different (sub)species of the species complex. This allowed for a more accurate estimate of the pressures on a mixed natural community.

## 2.2. Methods

### 2.2.1. General experimental design

All experiments were carried out in polypropylene mesocosm containers under outdoor conditions at the Living Lab field station or at the botanical garden of Leiden University, The Netherlands. The experiments focused on semi-realistic field conditions, as the temperatures, eutrophication levels and salinities are representative of a range of larval habitats (Alcalay et al., 2019; Ikeshoji and Mulla, 1970; Loeb and Verdonschot, 2008; Oude Essink et al., 2010; Roberts and Irving-Bell, 1997; Rockett, 1987; Wallis, 1954). The treatments were - unless mentioned otherwise - applied to 65 l black polypropylene mesocosms filled up to 30 l and placed in a second, fully buried identical mesocosm thus providing an air-filled layer of insulation to buffer temperature fluctuations (Krol et al., 2019).

Each mesocosm was filled with tap water and then spiked with a microbial community acquired by filtering a standardized amount of water from an adjacent lake through a  $\Phi$  200 nm plankton net with  $\Phi$  53  $\mu$ m collector, so that each volume of water in the mesocosms contained a similar microbial community to that found in the same volume of water in the lake. To simulate the different levels of eutrophication standardized dried cow manure (2.4 % N; 1.5 % P<sub>2</sub>O<sub>5</sub>; 3.1 % K<sub>2</sub>O) was added. The mesocosms were then left to incubate for a minimum of one week so that the microbial communities could stabilize. During this period, the mesocosms were covered with shading cloth to prevent Chironomidae and Culicidae colonization. After the acclimation period, all water within the mesocosms was filtered with a  $\Phi$  300  $\mu$ m sieve, to remove large particles and any remaining macro-invertebrates. Unless mentioned otherwise, *Culex pipiens* s.l. egg rafts were collected during a four-day period prior to the start of an experiment from naturally colonized black plastic buckets at the Living lab field station. Larvae were randomly selected and then added in random block design.

During the experiments all containers were covered with emergence traps (Cadmus et al., 2016) to prevent i) colonization by *Culex pipiens* s.l. mosquitoes and any other species that might compete with the experimental population, ii) mosquito predators from entering and iii) trap emerged adults. The water level was kept stable by daily replenishment of the evaporated volume with dechlorinated tap water after measurements were taken. The temperature in each mesocosm was recorded every thirty minutes for the duration of each experiment by a temperature logger (iButton DS1921G#F5D) near the water surface. Abiotic

conditions were measured weekly using a HACH HD40 for dissolved oxygen, pH and conductivity measurements, an Aquafluor 8000-010 for chlorophyll *a* and turbidity measurements and a Vernier Labquest2 for ammonium, chloride, nitrate and phosphor concentrations.

## 2.2.2. Experiments

### 2.2.2.1. Eutrophication-density interaction

The experiment on interactive effects of eutrophication and larval densities took place between August and October of 2020. Eutrophication levels were chosen so as to span the entirety of the oligotrophic-hypertrophic range with levels representing a low-eutrophic water body (5 mg/l N-total), a high-eutrophic water body (20 mg/l N-total) and a hypertrophic land puddle (100 mg/l N-total) (Loeb and Verdonschot, 2008). To simulate the different levels of eutrophication standardized dry cow manure (2.4 % N; 1.5 % P<sub>2</sub>O<sub>5</sub>; 3.1 % K<sub>2</sub>O) was added. Larval densities representative of 0.1, 1 and 10 egg rafts (20, 200 and 2000 larvae, respectively) were used to study the effects of increasing conspecific competition (Agnew et al., 2000). The treatments were applied with four replicates in a random block design.

Egg laying behavior was not measured within this experiment as the effects of eutrophication could be determined from experiment 2.2.2 and the effects of larval presence had already been studied (Mwingira et al., 2020).

### 2.2.2.2. Eutrophication-temperature interaction

The experiment on the interactive effects of eutrophication and temperature levels was conducted in 65 l black polypropylene mesocosms filled up to 30 l between April and June of 2020. Eutrophication levels were chosen as described in Section 2.2.1, additionally including a treatment representing rainwater (0 mg/l N-total). Temperature levels were selected around the optimal rearing temperature (Loetti et al., 2011) and set at 20, 25 and 30 degrees Celsius. Temperature treatments were regulated using 200 W heaters (HSaqua).

The treatments were applied with four replicates in a random block design. Twenty first instar larvae were added to each of the mesocosms. The low larval density served to exclude potential effects of density dependence (Alcalay et al., 2018). After the experiment, each mesocosm was filtered with a  $\Phi$  300  $\mu$ m sieve to remove any remaining (dead) larvae and/or pupae. The emergence traps were then removed and ovipositioning choice was scored for five consecutive days.

### 2.2.2.3. *Salinity and temperature interaction*

The experiment on interactive effects of salinity and temperature was conducted in white 12 l polypropylene mesocosms filled to 10 l during the months of May and June of 2021. The selected salinity levels were representative for the current and expected salinity levels encountered at the Dutch coastal areas, freshwater (0 g/l chloride), brackish (0.3 g/l chloride) and saline (1 g/l chloride) conditions (Oude Essink et al., 2010).

Salinity levels were applied using a sodium chloride stock solution. Temperature levels were selected near the optimal rearing temperature (Loetti et al., 2011) and set at 27 and 30 degrees Celsius. A eutrophication level of 20 mg N-total was applied to minimize competition over resources, as determined by the experiment described in Section 2.2.1. The salinity-temperature treatments were applied and 200 first instar larvae were added with three replicates in a random block design. Any pupa encountered during the experiment was counted and removed as the pupae do not eat and have a hardened exoskeleton (Becker et al., 2010), which limits their interaction with the environment (Balasubramanian et al., 2019; Mottram et al., 1994; Patrick and Bradley, 2000). Consequently, data on time to emergence and sex-ratio were not collected for this experiment.

To test the effect of salinity on ovipositioning choice, 5 blocks of five 12 l black mesocosms were prepared with a concentration that is representative of the range between freshwater and saltwater (0, 0.4, 1.6, 16 and 32 g/l sodium chloride). The blocks were distributed across the botanical gardens (80 m apart) in the shade. Egg rafts were collected for five consecutive days.

### 2.2.2.4. *Temperature fluctuations*

The experiment on the effects of increasing levels of temperature fluctuation was executed in white 12 l polypropylene mesocosms filled to 10 l between the end of March and beginning of May 2021. This experiment took place during the overwintering of the natural populations, so that the ambient temperature would not overtake the experimental temperatures. During this experiment, the water temperature conditions of an average day in June were mimicked. June is commonly regarded as the optimal month for mosquito development in NW Europe as the amount of sunlight energy is maximal (Becker et al., 2010).

To determine appropriate temperatures, water surface temperatures were monitored in three white 8 l containers with an interval of 30 min between the months of May and July 2020. From these data a mean, minimum and maximum temperature, as well as the temporal interval between these, were derived and used to set four treatments of increasing fluctuation with the same amount of energy applied per 24 h. These included a constant, block and curve scheme as well as a treatment with twice the amplitude of daily fluctuations, hereafter referred to as curve2 (Supplementary Figure 2.1). The treatments were temperature-controlled with thermostats and an Arduino UNO microcontroller. For this experiment *Culex pipiens pipiens* first instar larvae were obtained from culture from Wageningen University & Research, The Netherlands. The treatments were applied and 200 first instar larvae were added with five replicates in a random block design. A eutrophication level of 20 mg N-total was applied to minimize competition over resources, as determined during the experiment on interactive effects of eutrophication and larval density (see Section 2.2.1). Egg laying behavior was not measured within this experiment as temperature was determined to not affect larval habitat site selection during the experiment on interactive effects of temperature and eutrophication (see Section 2.2.2).

### 2.2.3. Rearing of larvae

For the experiment on temperature fluctuations *Culex pipiens pipiens* first instar larvae were obtained from culture from Wageningen University & Research, The Netherlands.

For the remaining experiments, *Culex pipiens* s.l. egg rafts were collected during the four days prior to the start of an experiment from naturally colonized black plastic buckets at the Living lab field station. For this, the buckets were filled with 6 l hypertrophic water (100 mg N-total). The larvae were subsequently allowed to hatch in white 12 l mesocosms containing 10 l of lake water where they were kept at ambient temperature until the start of the experiment. Previous pilot studies indicated that this type of experiments attracts *Culex pipiens* only. The collected egg rafts were distinguished from those of *Culiseta annulata* by their difference in size (Chapman et al., 2020; Sames et al., 2005).

### 2.2.4. Measurements and life stage identification

Larval development was measured five days a week by stirring clockwise once with a 400 mm wide  $\Phi$  200  $\mu$ m sieve to create a circular water flow to prevent the larvae from diving. The sieve was subsequently used to collect the larvae by

2 fully submerging the sieve and moving anti-clockwise twice. All collected larvae were morphologically characterized to developmental stage by using the size of the head capsule as a morphological indicator (Becker et al., 2010). The identifications were compared daily with a previously reared reference collection of *Cx. pipiens* developmental stages. The procedure was repeated up to five times until at least five, twenty or a hundred larvae were sampled for the densities of 20, 200 and 2000, respectively.

Each day, emerged mosquitoes were collected with an aspirator and sex was determined based on characteristics including, but not limited to, plumose/pilose antennae, and the length of the palps (Becker et al., 2010). The survival rate was determined by dividing the number of adults that had emerged by the applied density. The median time to pupation was defined as the interval between the start of the experiment and the first day upon which at least 50 % of the subsampled larvae had turned/developed into pupae. The median time to emergence was determined by calculating the interval between the start of the experiment and capture of 50 % of the emerged adults. When no more pupae and adult mosquitoes were found for two subsequent days in a mesocosm, it was assumed that there were no living mosquitoes left and the mesocosm was closed off.

Ovipositioning behavior was recorded by daily counts of egg rafts per mesocosm per day. Encountered egg rafts were removed to minimize the positive feedback caused by their presence (Bruno and Laurence, 1979).

### 2.2.5. Statistical analysis

All data were analyzed in R version 4.04 (R Core Team, 2022). Differences in survival, development, sex-ratio and ovipositioning behavior between and within eutrophication and density levels, between and within eutrophication and temperature levels and between levels of temperature fluctuation, were tested with general linear models comparing the number of emerged mosquitos, average development stage, the number of emerged mosquitoes per sex and the number of egg-rafts respectively. Dissolved oxygen, nitrate, ammonium, and chloride levels as well as chlorophyll  $\alpha$  concentrations were included as main effects. The effects of survival, development and ovipositioning behavior between and within salinity and temperature levels, were tested with general linear models comparing the number of emerged mosquitos, average development stage and the number of egg-rafts respectively. For this, chlorophyll  $\alpha$  and dissolved oxygen

concentrations were included as main effects. Lastly, the effects of survival and development between and within salinity and temperature levels, were tested with general linear models comparing the number of emerged mosquitos and average development stage. For this, chlorophyll  $a$  and dissolved oxygen concentrations were included as main effects. All (16) corresponding full models are presented in Supplementary Table 2. Covariates and their interactions were stepwise removed from the full models during model optimization if not significant and if the Akaike information criterion indicated a worse fit of the data.

## 2.3. Results

As the aim of this paper is to shed light on the effect that anthropogenic pressures have on each of the population parameters, the results have been grouped per dependent variable. This facilitated the comparison of effects between the different pressures. Estimated regression coefficients and standard errors for each of the tests are listed in Supplementary Table 2.

### 2.3.1. Impact of anthropogenic pressures on absolute survival

Absolute survival rate was not impacted by different levels of temperature, temperature fluctuations, or combined effects of temperature and eutrophication within the ranges tested ( $p > 0.1$ ). Survival did however decrease under increasing temperatures within the saline treatment ( $F(22,178) = 1.983$ ,  $p < 0.01$ , partial  $\omega^2 = 0.073$ , power = 0.964). Post hoc analysis revealed significant differences in survival between the highest salinity at 30 degrees and lowest salinity at 27 degrees for day 7 of the experiment and between the two temperatures at the highest salinity for days 7 and 10 ( $p < 0.05$  after Bonferroni correction) (Figure 2.2a). Survival also decreased with increased conspecific density ( $F(2, 25) = 11.613$ ,  $p < 0.001$ , partial  $\omega^2 = 0.384$ , power = 0.994) and decreasing amounts of food per capita ( $F(4, 25) = 5.745$ ,  $p = 0.002$ , partial  $\omega^2 = 0.358$ , power = 0.981). Post hoc analysis revealed significant differences between the oligotrophic treatment with 2000 larvae and all other treatments ( $p < 0.001$ , Bonferroni correction) as well as among the hypertrophic treatments with 20 and 200 larvae ( $p < 0.05$ , Bonferroni correction; Figure 2.2d).

### 2.3.2. *Impact of anthropogenic pressures on time to pupation*

Development time up to pupation decreased significantly with increasing temperatures in both the salinity experiment ( $F(1,15) = 4.868$ ,  $p < 0.05$ , partial  $\omega^2 = 0.156$ , power = 0.594; Figure 2.3a) and the experiment on interactive effects of eutrophication and temperature ( $F(2,40) = 38.57$ ,  $p < 0.001$ , partial  $\omega^2 = 0.620$ , power = 1; Figure 2.3c) by 7 and 3 days, respectively. Additionally a trend was found for the interaction between temperature and salinity ( $F(2,15) = 2.709$ ,  $p < 0.1$ , partial  $\omega^2 = 0.140$ , power = 0.529). Post hoc analysis revealed that this was caused by a trend in contrasts between the temperatures within highest salinity level ( $p < 0.06$ , Bonferroni correction) (Figure 2.3a). Increasing levels of temperature fluctuation also decreased development time up to pupation. Differences were detected between the constant and curve treatments ( $\chi^2 = 2.017$ ,  $p = 0.022$ ) and the constant and curve 2 treatments ( $\chi^2 = 2.711$ ,  $Df = 3$ ,  $p = 0.003$ ) (Figure 2.3b). No solitary or interactive effects of eutrophication level were found (Figure 2.3c) except at higher densities, where decreasing amounts of food per capita resulted in longer development times. This was true when manipulating the eutrophication level ( $F(2, 25) = 22.286$ ,  $p < 0.001$ , partial  $\omega^2 = 0.556$ , power = 1), density ( $F(2, 25) = 5.924$ ,  $p = 0.008$ , partial  $\omega^2 = 0.225$ , power = 0.876) and the combination of the two ( $F(4, 25) = 3.012$ ,  $p = 0.037$ , partial  $\omega^2 = 0.191$ , power = 0.802). Post hoc analysis revealed significant contrasts between the oligotrophic treatment with 2000 larvae (a) and all other treatments (b) ( $p < 0.001$ , Bonferroni correction; Figure 2.3d).

### 2.3.3. *Impact of anthropogenic pressures on time to emergence*

Development up to emergence was similarly impacted as development times decreased with increasing temperatures ( $F(3, 41) = 230.7$ ,  $p < 0.001$ , partial  $\omega^2 = 0.936$ , power = 1; Figure 2.4b). Increasing levels of temperature fluctuations lowered development time ( $F(3, 14) = 230.7$ ,  $p < 0.001$ , partial  $\omega^2 = 0.833$ , power = 1). Post hoc analysis indicated differences between the constant treatment (a) and all other treatments (b, c) ( $P < 0.001$ , Bonferroni correction) and between the block (b) and curve treatments (c) ( $p < 0.05$ , Bonferroni correction; Figure 2.4a). Eutrophication did not impact development under low densities but did so under higher densities (Figure 2.4c). Decreasing amounts of food per capita increased time to emergence when manipulating eutrophication levels ( $F(2, 25) = 19.429$ ,  $p < 0.001$ , partial  $\omega^2 = 0.520$ , power = 1), density ( $F(2, 25) = 4.246$ ,  $p = 0.026$ , partial  $\omega^2 = 0.160$ , power = 0.741) and a trend was detected when altering both ( $F(4, 25) = 2.297$ ,  $p = 0.087$ , partial  $\omega^2 = 0.132$ , power = 0.672). Post hoc

analysis revealed significant contrasts between the oligotrophic treatment with 2000 larvae (b) and all other treatments (a) ( $p < 0.001$ , Bonferroni correction; Figure 2.4c).

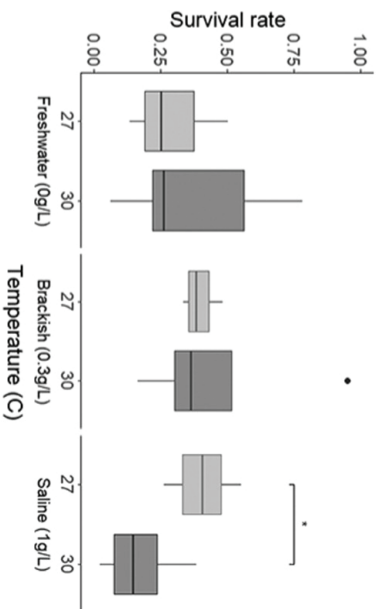
#### 2.3.4. *Impact of anthropogenic pressures on sex ratio*

The proportion of females increased with increasing temperatures ( $F(2, 40) = 38.57$ ,  $p < 0.001$ , partial  $\omega^2 = 0.620$ , power = 1; Figure 2.5b) and between the eutrophic and hypertrophic treatments ( $H(2) = 9.5126$ ,  $p = 0.015$ ; Figure 2.5c) within the highest density. The sex ratio was not impacted by temperature fluctuations and density within the ranges tested ( $p > 0.05$ ). No other effects on sex ratio were detected.

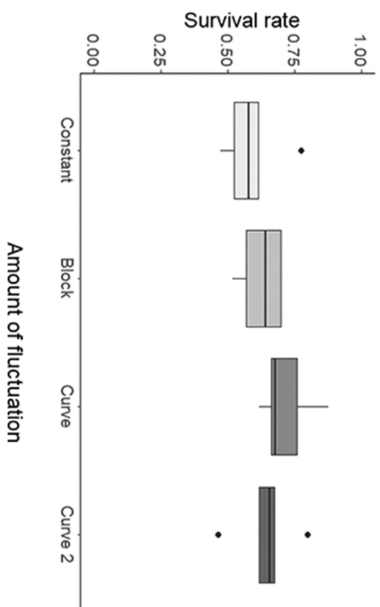
#### 2.3.5. *Impact of anthropogenic pressures on ovipositioning behavior*

Egg laying behavior decreased with increasing salinity ( $F(16,63) = 8.480$ ,  $p < 0.001$ , partial  $\omega^2 = 0.491$ , power = 1, Figure 2.6a). Post hoc analyses revealed a contrast between the treatments 16 g/l and 32 g/l and all lower salinities after day 1 of the experiment ( $p < 0.05$ , Bonferroni correction). Ovipositioning behavior also increased with increasing eutrophication ( $\chi^2 = 32.857$ ,  $df = 3$ ,  $p < 0.001$ , Figure 2.6b). Post-hoc analysis indicated a difference between the hypertrophic treatment (b) and all other eutrophication levels (a).

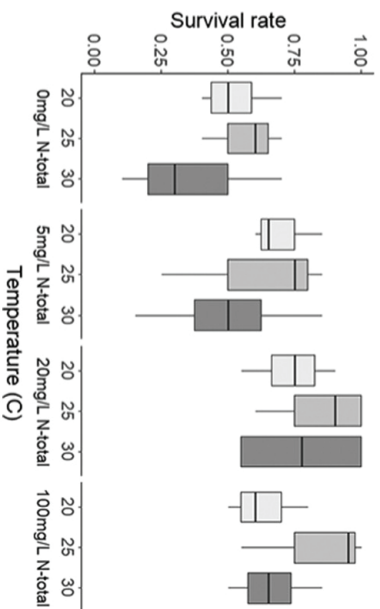
A



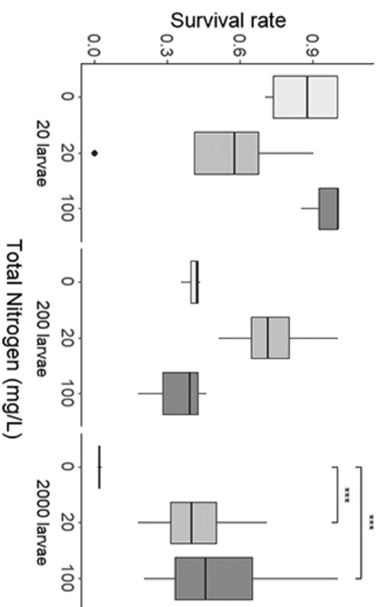
B



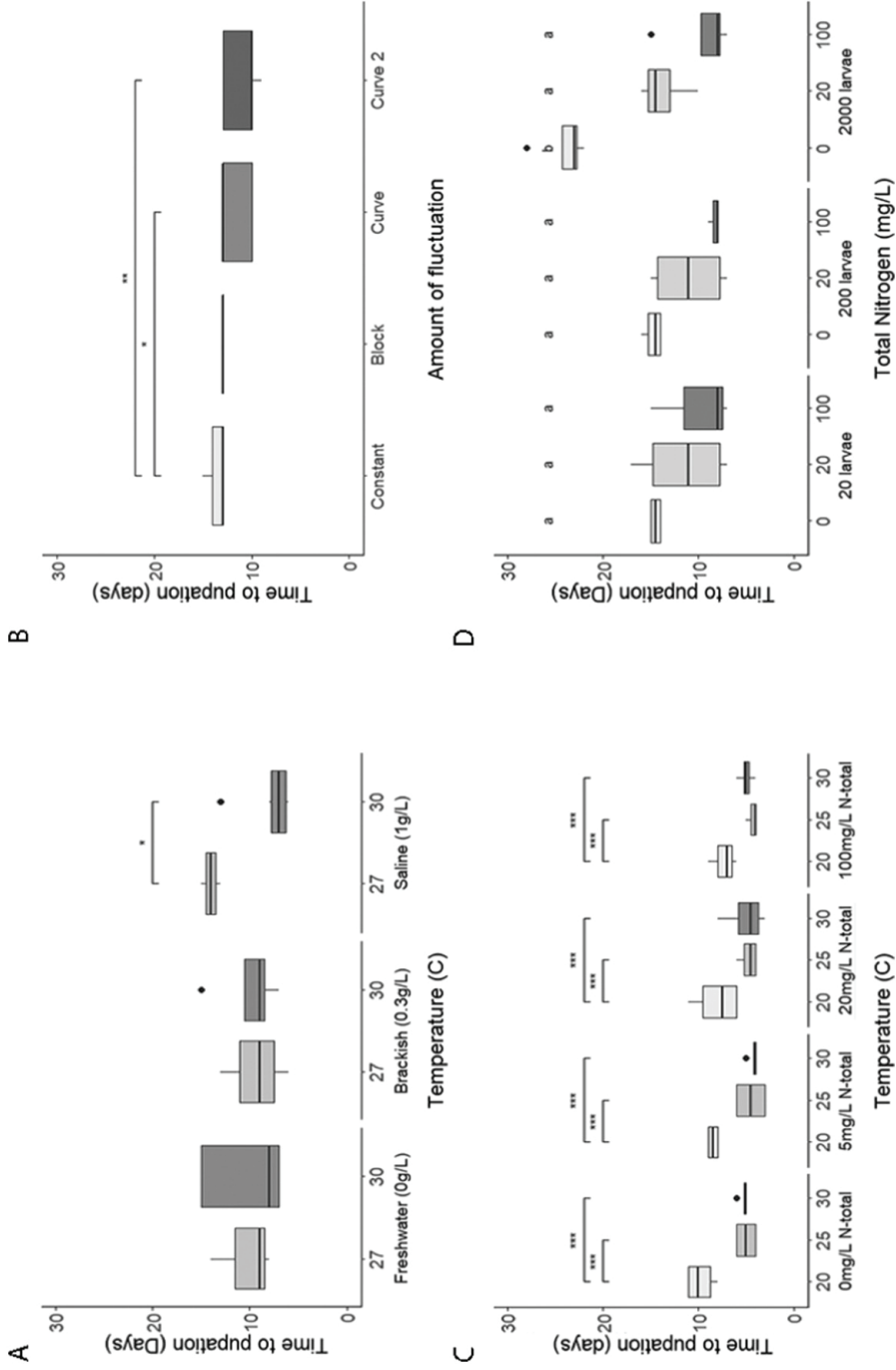
C



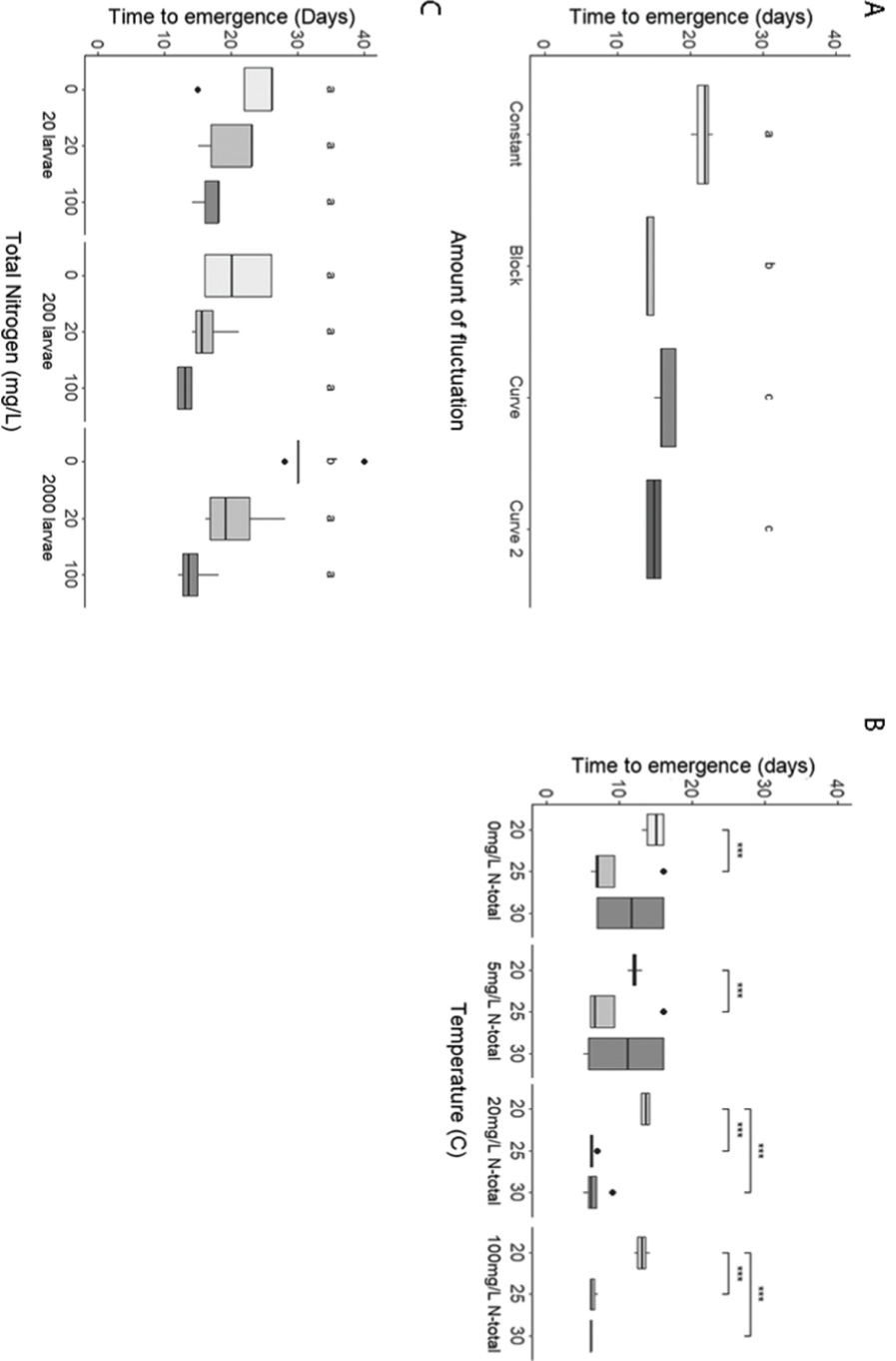
D



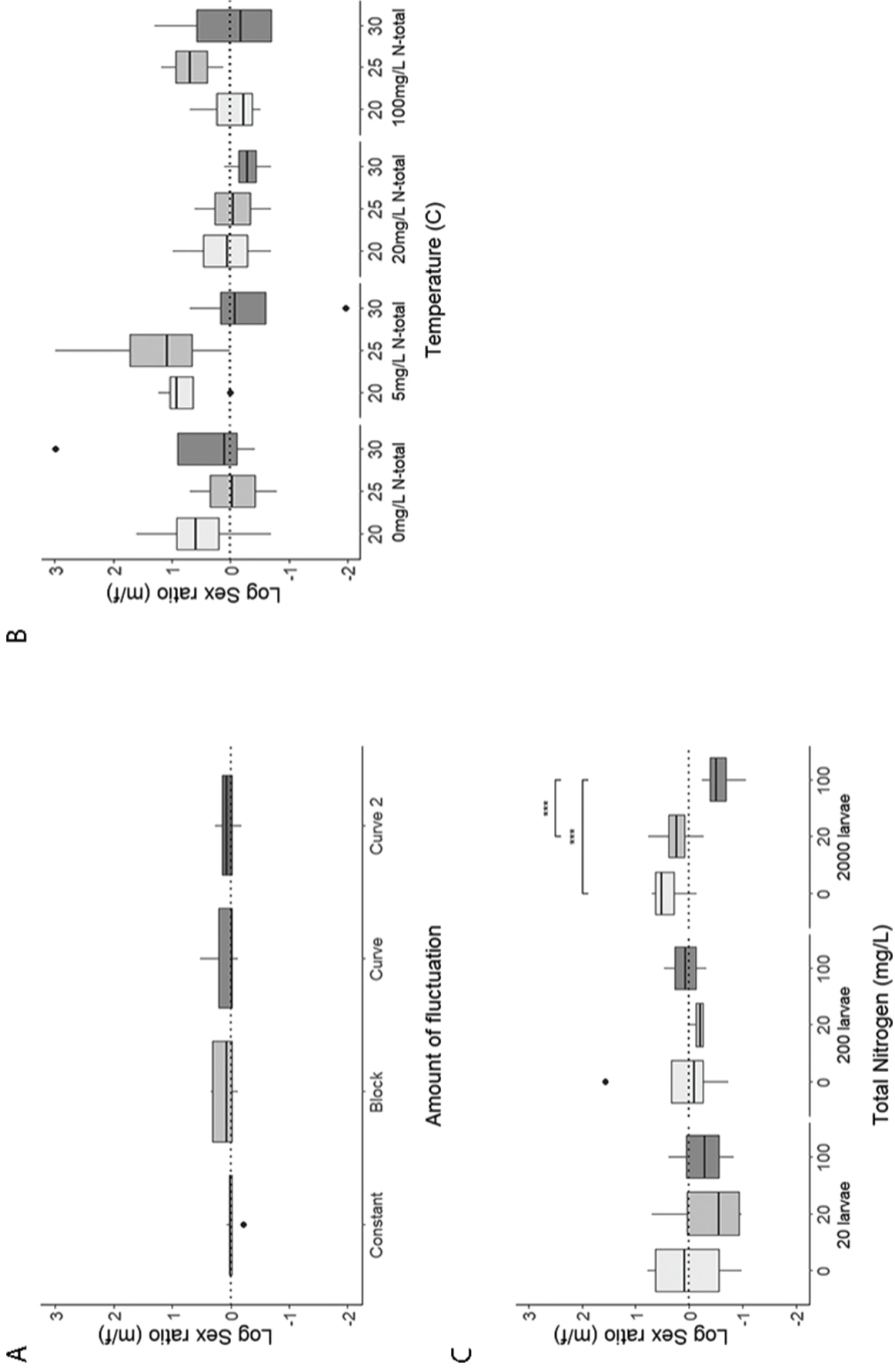
**Figure 2.2** Absolute survival rate across different anthropogenic pressures. Absolute survival rate depicted as the number of emerged adults as a fraction of the initial number of larvae at the end of each experiment for A. effects of salinity at different temperatures, B. increasing levels of temperature fluctuation, C. effects of increasing eutrophication at different temperatures and D. effects of eutrophication at different densities.



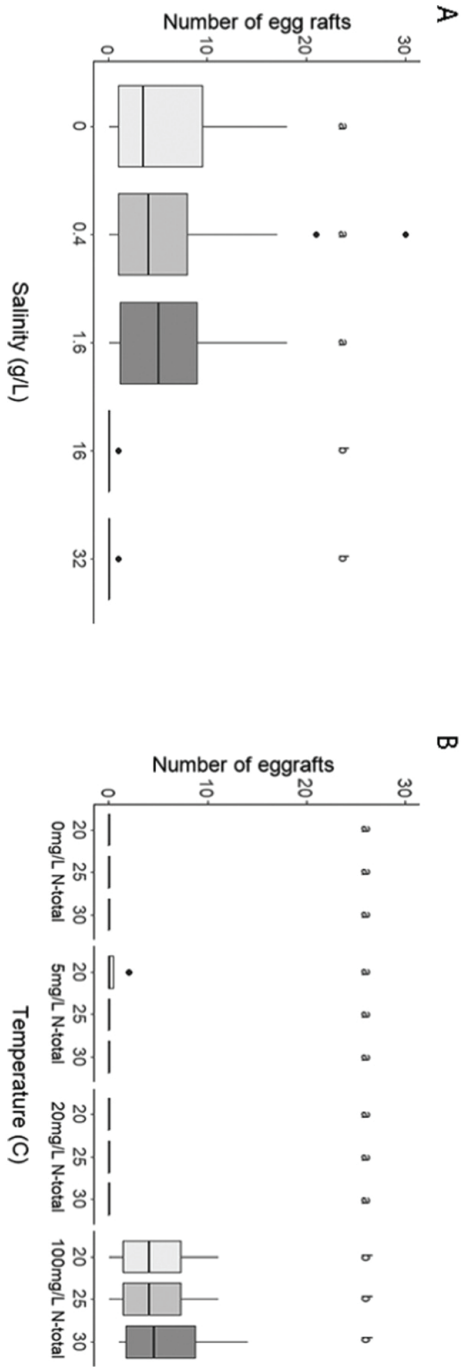
**Figure 2.3** Median time to pupation across different anthropogenic pressures. Time to pupation in days at the end of each experiment for A. temperature grouped by salinity, B. increasing levels of temperature fluctuation, C. temperature grouped by eutrophication and D. eutrophication grouped by density. a, b Significantly contrasting groups.



**Figure 2.4** Median time to emergence across different anthropogenic pressures. Time to emergence in days at the end of each experiment for A. increasing levels of temperature fluctuation, B. temperature grouped by eutrophication and C. eutrophication grouped by density. a, b, c Significantly contrasting groups.



**Figure 2.5** Sex-ratio (SR) across different anthropogenic pressures. Male to female sex ratio (transformed as natural logarithm) at the end of each experiment for A. increasing levels of temperature fluctuation, B. temperature grouped by eutrophication and C. eutrophication grouped by density.



**Figure 2.6** Ovipositioning behavior across different anthropogenic pressures. Number of egg rafts for A. temperature grouped by salinity, B. temperature grouped by eutrophication. a, b Significantly contrasting groups.

## 2.4. Discussion

Anthropogenic pressures are mounting in a fast-changing world. This study assessed the life-history responses of *Cx. pipiens* to the three most prominent anthropogenically induced pressures that act directly on the mosquito larval habitat: eutrophication, temperature, and salinization. A series of full-factorial mesocosm experiments demonstrated that each of these pressures, together shaping the larval habitat, are relevant during different immature life-stages. Overall, the results suggest large and previously underestimated impacts of multiple pressures – both single and interactive – on mosquito population dynamics, well beyond the impact of changes in temperatures. However, the direction and magnitude of the effect of stressors on the investigated mosquito life history parameters, differs profoundly between the investigated stressors. Also, while interactive effects between stressors were common, some interactions are more important than others. These are further discussed in the following paragraphs.

### 2.4.1. Impacts of anthropogenic pressures on mosquito survival and development time

While eutrophication and conspecific density had large, consistent effects on larval survival, exposure to different temperature regimes and differences in salinity levels only showed effect on development time. These results likely reflect different physiological processes. Eutrophication acts directly on resource competition, temperature acts on metabolic rate and salt has a toxic though sublethal effect (Balasubramanian et al., 2019; Emidi et al., 2017). Indeed, under decreasing levels of eutrophication, larval survival was markedly lower as a result of fierce competition over resources (El Hussein et al., 2018; Merritt et al., 1992; Reisen et al., 1984). This is abundantly clear when comparing the survival under the hypertrophic treatment (45 %) to that in the oligotrophic treatment (<1 %). Similar effects were found when comparing the survival at the highest larval densities (40 %) to the lowest densities (55 %) at average eutrophication levels. This effect has been reported to be even stronger when several developmental stages are present, as mosquito larvae have repeatedly been observed to cannibalize on lower instars (El Hussein et al., 2018; Koenraadt and Takken, 2003). The effect of salinity had a negatively and stepwise effect on the larval energy budget, likely because the toxic chloride needs to be expelled actively within *Culex* larvae (Bradley, 1987; Donini et al., 2007; Bradley and Phillips, 1976; Patrick and Bradley, 2000), thus slowing larval development (Clark et al., 2004). The higher instars seemed disproportionately more sensitive to this effect, which can be explained by the lower surface-to-volume ratio of higher instars. Within

the investigated temperature ranges, which mimic optimal rearing conditions, a marked effect of temperature on development time was observed, which is in line with previously reported effects that relate this to an increase in metabolic rate. Overall, the results suggest that single effects of the investigated stressors on mosquito population parameters are present in each of the mosquito life history parameters and follow directly from the physiological processes they act on.

Although the results of the interactive experiments are far more complex, in general terms they follow a very similar pattern. An illustration of this is the interactive effect of temperature with salinity and eutrophication. As temperature increases the metabolic rate, higher temperatures can be expected to lead to speeding up the single effects of both stressors. Indeed, the experimental results show that survival rate at oligotrophic conditions was lower when larvae were exposed to higher temperatures. Likewise, larval survival at higher levels of salinity was lower when larvae were exposed to higher temperatures. As these results were all collected within a relevant parameter range for the current northern European situation, it is difficult to make any inferences outside this range. For example to delta regions in tropical areas that struggle with salinization such as the region around the Mekong delta (Bauer et al., 2022). Likewise, higher temperature ranges may alter the effect of other stressors. Indeed, several experiments have reported lethal effects of temperatures above 30 degrees Celsius (Ciota et al., 2014; Loetti et al., 2011), but it is unknown whether this might change when interacting with other stressors. One effect that might be accentuated is the masking effect, where eutrophic conditions could mask temperature stress by facilitating rapid emergence, similar to what has been observed with its effect on pesticide toxicity (Barmantlo et al., 2018). A comparable exacerbation of stressor effects by interaction with mean temperature might be present for increasing temperature fluctuations, as these seem to further increase metabolic rates which are discussed below. Although the experiments took place during different periods of the year, no confounding effects of photoperiod on development time were expected, as most experiments were conducted before mid-summer and diapause generally sets on after August (Robich and Denlinger, 2005). Additionally, diapause-associated developmental alterations take place during adulthood (Robich and Denlinger, 2005; Zhou and Miesfeld, 2009), whereas these experiments were limited to sub-adult development.

#### 4.2. *Impact of fluctuating temperature regimes*

The impacts of higher constant temperature on larval development rate are clear and widely acknowledged (van der Have and de Jong, 1996). The experiments demonstrated similar effects both prior to and during metamorphosis, irrespective of nutrient availability, but strengthened by increased salinity. Moreover, the results show that fluctuations in temperature have large effects on larval development time, well beyond what was expected. Larval development time, at natural temperature fluctuations, was on average 7 days shorter than under constant temperature regime. Several authors have previously hypothesized that temperature fluctuations might have a large effect on insect growth rate (Alcalay et al., 2018; Hagstrum and Milliken, 1991; Loetti et al., 2011). The experimental results also show that most of these differences arise during pupation (Figure 2.3). This is probably caused by temperature sensitivity of a multitude of enzymatic reactions around different optimum temperatures impacting enzymatic activity and thereby metabolic rate, possibly as an evolutionary adaptation in cold-blooded organisms, as has been found in insects in general (Behrens et al., 1983; Hagstrum and Milliken, 1991).

#### 2.4.3. *Impacts of anthropogenic pressures on sex-ratio of mosquitoes*

Anthropogenic pressures may have different effects on male and female mosquitoes, thus leading to sex-specific life history trajectories (Alcalay et al., 2018). For instance, although bigger males and females both live longer (Reisen et al., 1984), comparably lower natural selection for size might push males towards early maturation, leading to smaller sizes and wing length (Alcalay et al., 2018; Loetti et al., 2011; Reisen et al., 1984; Virginio et al., 2015). The longer average development time of female mosquitoes may also result in prolonged exposure to stress, potentially making them more vulnerable (Hamaidia and Soltani, n.d.; Schrama et al., 2018; Virginio et al., 2015). These experiments show that significantly fewer females survived under the highest density where food-stress was most prominent. Female abundance was higher at higher temperatures, irrespective of eutrophication level, which might be due to higher development rates allowing for earlier emergence and subsequent lower exposure to competition and chemical stressors such as secondary metabolites produced by cyanobacteria. Sex ratio was not affected by temperature fluctuations or density, the latter of which indicates that cannibalism is opportunistic and does not select for certain sexes, which is in line with Loetti et al. (2011)'s notion that sexual dimorphism in growth rate only exists from the fourth larval development stage onwards. Overall, our findings indicate that expected rising temperatures and nutrient pollution will lead

to a higher female survival. As females represent the sex transmitting pathogens, this may have implications for disease transmission.

### 2.4.4. Impacts of anthropogenic pressure on egg-laying behavior of mosquitoes

The results show a pronounced impact on ovipositioning behavior for chemical cues (eutrophication and salinization), but no impact of temperature. These results are in line with the notion that *Cx. pipiens* is widely known to actively seek and evaluate temporal water bodies by sensing gaseous substances (Becker et al., 2013), bacteria (Buxton et al., 2020; Dhileepan, 1997; Hasselschwert and Rockett, 1988), pheromones (Day, 2016; Ko and Eliel, 1986; Michaelakis et al., 2005) and visual cues (Bentley, 1989; Ortiz Perea and Callaghan, 2017). Thus, increasing levels of eutrophication, and the higher levels of bacterial activity that resulted from this, were indeed preferred during egg laying, as females oviposited exclusively in the hypertrophic treatment. Likewise, increasing salinity levels impacted ovipositioning behavior, though it is unclear whether ovipositioning responded directly to high salt levels or whether it occurred through salt-induced changes in bacterial composition. No measurable effect of temperature on ovipositioning was observed, which is unexpected as higher water temperatures in larval habitats have very large impact on larval development rate, suggesting that the response is primarily chemically induced rather than physically. Thus, changes in water pollution or salt content may have far ranging consequences for ovipositioning, reinforcing some of the previously observed effects on development rate and survival.

### 2.4.5. Implications

The planetary boundary framework (Steffen et al., 2015) is commonly acknowledged as a concept defining the global drivers of environmental change and the safe operating space for humanity within them. Crossing the boundaries increases the risk of large-scale and irreversible environmental changes. There is widespread consensus that, for the vast majority of species, crossing the planetary boundaries leads to long term negative effects at the individual or population level (Wu et al., 2021). So far, evidence for the effects on infectious diseases had remained fragmented (Butler, 2012). Our results indicate that mosquito species may be suffering far less or even benefiting from large scale environmental change. Furthermore, the fact that the effect of most of these stressors was exacerbated by increasing temperatures illustrates how ongoing crossing of planetary boundaries may lead to even more beneficial habitat conditions. As such, these results underscore the importance of changes in environmental conditions

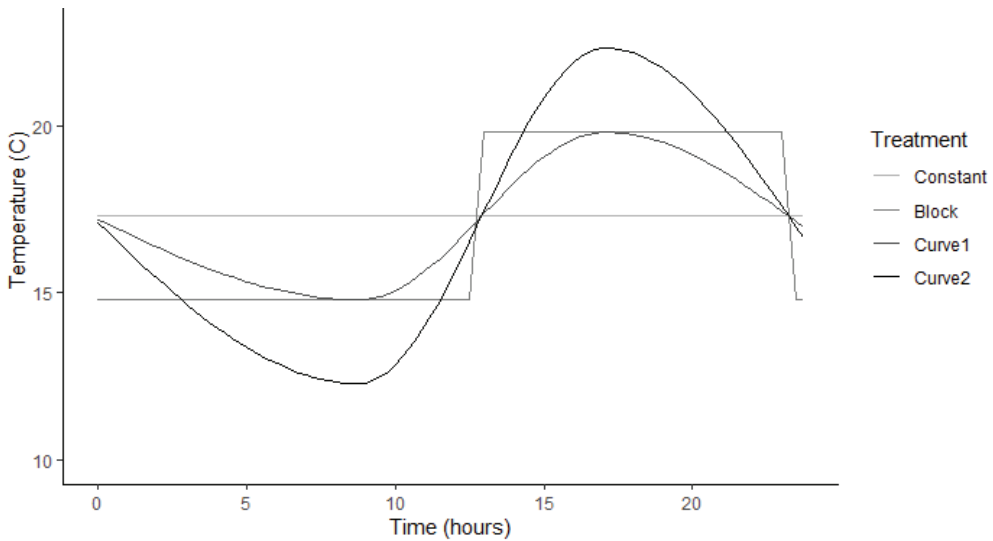
(Lambin et al., 2010; Schrama et al., 2020) by identifying its consistent pattern across a range of important stressors and climatic conditions. Given the global extent and intensity of the investigated anthropogenic pressures, these results are likely relevant for a wide array of disease vectors and provides a mechanism for the association between ecosystem degradation and disease. Overall, these results strongly suggest that the planetary boundary concept has important consequences for changes to mosquito abundances and likely feeds through to changes in disease risk, thus highlighting the need to further include these in models and interventions. The crucial question is, however, whether the mosquitoes are better adapted to these changes than their predators and (invasive) competitors, whose ranges are expanded due to human activities (Costanzo et al., 2005). As such, extended work is needed on interactions with(in) biotic pressures, including interspecific competition and predation.

## **CRedit authorship contribution statement**

SB and MS conceived the general idea for the experiments. SB set up the experiments and carried out the measurements together with EJ, AU and LK. SB carried out all statistical analysis, with feedback provided by PB and MS. EB, EJ, MS and PB contributed to the writing of the manuscript. All authors read and approved the final manuscript.

## **Acknowledgements**

Pieter Rouweler & Sander Koenraadt are gratefully acknowledged for supplying mosquitoes from the Wageningen University rearing facility. Many thanks to Anniek de Jong, Niels van der Windt, Kiki Streng, Karsten de Wit, Antje van der Gaast, Neal Corneth, Olaf van Raalte, Robin Vergeer and Casper Braams for their help with setting up the experiments. Afonso Dimas-Martins is thanked for his comments on the setup of the salinity data. Sincere thanks to Martha Dellar and Marc Weeber for their help during the writing of the manuscript. Many thanks to Lois van Laere for her help in designing the graphical abstract.



**Figure S2.1** Treatments of increasing temperature fluctuation. Overview of the four levels of temperature fluctuation used during the experiment. All four treatments result in the same amount of degree days. The maximum, minimum and mean temperatures as well as the daylength were derived by averaging aquatic surface temperatures from May and July 2020.

**Table S2.1** Non-exhaustive overview of relevant literature for each of the established relationships between pressure and states.

Pressure	State	References <sup>1</sup>
Temperature	Development speed	(Loetti et al. 2011; Mottram et al. 1994; Petrić et al. 2014; Reisen et al. 1984; Spanoudis et al. 2019)
	Survival rate	(Loetti et al. 2011; Mottram et al. 1994; Reisen et al. 1984; Spanoudis et al. 2019)
	Sex ratio (m/f)	(Loetti et al. 2011; Reisen et al. 1984; Spanoudis et al. 2019)
Salinization	Survival rate	(Balasubramanian et al. 2019; Bradley and Phillips 1976; Clark, Flis, and Remold 2004; Donini et al. 2007; Mottram et al. 1994; Silberbush et al. 2014)
	Ovipositioning	(De Brito Arduino et al. 2015; Hudson 1956; Navarro et al. 2003; Ramasamy and Surendran 2012, 2016; Roberts and Irving-Bell 1997)
Eutrophication	Development speed	(Buxton et al. 2020; Krol et al. 2019; Merritt et al. 1992; Reisen et al. 1984; Rejmánková et al. 2013; Schrama et al. 2018)
	Survival rate	(Krol et al. 2019; Merritt et al. 1992; Reisen et al. 1984; Rejmánková et al. 2013; Schrama et al. 2018)
	Sex ratio (m/f)	(Reisen et al. 1984)
	Ovipositioning	(Bentley 1989; Bond et al. 2005; Buxton et al. 2020; Day 2016; Dhileepan 1997; Ikeshoji and Mulla 1970; Navarro et al. 2003; Rockett 1987)

<sup>1</sup> Studies on direct (experimental) links between pressures and states were collected by use of the query “‘*Culex pipiens*’ AND populations AND (immature OR larva\*) AND (survival OR development OR “sex ratio” OR “ovipositioning behavior”) AND (eutrophication OR salinization OR temperature OR “temperature fluctuation”) AND interacti\*\* -insecticide’. When no literature was found for this species, additional searches were performed for other species within its genus or else for the genera *Aedes* or *Anopheles*.

## Chapter 2

**Table S2.2.** Model coefficients. Estimated regression coefficients, standard errors and other values for the various statistical analyses of the results of experimental tests on *C. pipiens*.

Stressor	Population Parameter	Formula	Variable	Estimate	Std. Error	t value	Pr(> t )
Temperature	Survival rate	survival_rate ~ Treatment	(Intercept)	118.4	9.486569	12.4808025	1.16E-09
			Treatment-Block	6.6	13.416035	0.4919486	6.29E-01
			Treatment-Curve	25.2	13.416035	1.8783493	7.87E-02
			Treatment-Curve2	10.2	13.416035	0.7602842	4.58E-01
Sex ratio	sex_ratio ~ Treatment	(Intercept)	0.97788	0.1040257	9.40E+00	1.12E-07	
		Treatment-Block	0.16664	0.1471145	1.13E+00	2.75E-01	
		Treatment-Curve	0.17644	0.1471145	1.20E+00	2.49E-01	
		Treatment-Curve2	0.090245	1.56E-01	0.5783508	5.72E-01	
Time to pupation	TTP ~ Treatment	(Intercept)	13.6	5.92E-01	22.988	1.11E-13	
		Treatment-Block	-0.6	8.37E-01	-0.717	4.84E-01	
		Treatment-Curve	-1.8	8.37E-01	-2.151	4.71E-02	
		Treatment-Curve2	-2.6	0.8367	-3.11E+00	0.00677	
Time to emergence	TTE ~Treatment	(Intercept)	21.66667	0.6374553	33.989314	7.43E-15	
		Treatment-Block	-7.26667	0.8063242	-9.01209	3.33E-07	
		Treatment-Curve	-5.06667	0.8063242	-6.283659	2.01E-05	
		Treatment-Curve2	-6.66667	0.8063242	-8.267973	9.31E-07	
Eutro:Temp	Time to pupation	TTP ~ O2 + Eutrophication + Temperature	(Intercept)	4.148	1.53879	2.696	1.03E-02
			O2	0.02741	0.02276	1.204	0.2357
			Eutrophication1	-0.09498	0.72558	-0.131	0.8965
			Eutrophication2	-0.77008	0.55532	-1.387	0.1734

		Eutrophication3	0.12179	0.37016	0.329	0.7439	
		Temperature1	2.34313	0.29348	7.984	9.95E-10	
		Temperature2	-1.25789	0.28737	-4.377	8.73E-05	
Time to emergence	TTE ~ Temperature	(Intercept)	8.1661	0.1195	68.35	2.00E-16	
		Temperature1	4.2339	0.1688	25.08	2.00E-16	
		Temperature2	-1.8804	0.1718	-10.94	7.09E-14	
Ovipositioning	Rafts ~ Eutrophication	(Intercept)	1.3333	0.3477	3.835	0.0004	
		Eutrophication1	-1.3333	0.6022	-2.214	0.03206	
		Eutrophication2	-1.1667	0.6022	-1.937	0.05916	
		Eutrophication3	-1.3333	0.6022	-2.214	0.03206	
Salinity	Survival rate	survival_rate ~ Treatment * Temperature * Day + Error(Cosm/(Treatment*Day))	Control:Brackish	0.2407	0.138	1.747	0.2172
			Control:Saline	-0.0224	0.143	-0.157	0.9866
			Brackish:Saline	-0.263	0.146	-1.804	0.198
			Control:Brackish	8.12	16.2	0.503	0.8711
Time to pupation	TTP ~ Treatment * Day * Temperature + Error(Cosm/(Treatment*Day))	Control:Saline	6.48	18.5	0.35	0.9349	
		Brackish:Saline	-1.65	18.7	-0.088	0.9958	

## Chapter 2

<i>Stressor</i>	<i>Population Parameter</i>	<i>Formula</i>	<i>Variable</i>	<i>Sum Sq</i>	<i>Mean Sq</i>	<i>F value</i>	<i>Pr(&gt;F)</i>
Salinity	Ovipositioning	Rafts ~Location * Day + Treatment * Day + Error(Cosm/(Treatment * Day))	Day	4211	1052.8	46.883	2.00E-16
			Location:- Day	842	52.6	2.344	0.00861
			Day:Treatment	3047	190.4	8.48	2.07E-10
			Residuals	1415	22.5		
Eutro:Temp	Survival rate	survival_rate ~ Eutrophication + Temperature	Eutrophication	0.3115	0.10382	1.902	0.145
			Temperature	0.1329	0.06646	1.218	0.307
			Residuals	2.1286	0.05458		
	Sex ratio	Sex_ratio ~ Eutrophication + Temperature	Eutrophication	43.9	14.636	0.896	0.452
			Temperature	7.4	3.692	0.226	0.799
			Residuals	653.6	16.34		

Biting the hand that feeds

Eutro:Density	Survival rate	Survival_rate ~ Eutrophication * Density	Density	152.7	76.3	4.246	0.0259
			Eutrophication	698.7	349.3	19.429	8.11E-06
			Density:Eutrophication	165.2	41.3	2.297	0.0872
			Residuals	449.5	18		
Time to pupation	TTP ~ Eutrophication * Density	Density	116.2	58.09	5.924	0.00784	
		Eutrophication	437.1	218.55	22.286	2.78E-06	
		Density:Eutrophication	118.2	29.54	3.012	0.03708	
		Residuals	245.2	9.81			
Sex ratio	Sex_ratio ~ Eutrophication + Density	Density	0.31	0.1551	0.204	0.817	
		Eutrophication	2.875	1.4375	1.888	0.172	
		Density:Eutrophication	1.379	0.3447	0.453	0.77	
		Residuals	19.038	0.7615			
Time to emergence	TTE ~ Eutrophication * Density	Density	152.7	76.3	4.246	0.0259	
		Eutrophication	698.7	349.3	19.429	8.11E-06	
		Density:Eutrophication	165.2	41.3	2.297	0.0872	
		Residuals	449.5	18			



Fourth instar larvae of the house mosquito

## Chapter 3

### **In the heat of the moment:**

*including realistic thermal fluctuations using an open-source thermoregulator results in dramatically altered key population parameters*



*Ecology & Evolution (2024)*  
*DOI: 10.1002/ece3.70124*

Sam P. Boerlijst, Eline Boelee, Peter M. van Bodegom  
and Maarten Schrama



## Abstract

Temperature is commonly acknowledged as one of the primary forces driving ectotherm vector populations, most notably by influencing metabolic rates and survival. Although numerous experiments have shown this for a wide variety of organisms, the vast majority has been conducted at constant temperatures and changes therein, while temperature is far from constant in nature, and includes seasonal and diurnal cycles. As fluctuating temperatures have been described to affect metabolic processes at (sub)cellular level, this calls for studies evaluating the relative importance of temperature fluctuations and the changes therein. To gain insight in the effects of temperature fluctuations on ectotherm development, survival, and sex-ratio, we developed an inexpensive, easily reproducible, and open-source, Arduino-based temperature control system, which emulates natural sinusoidal fluctuations around the average temperature. We used this novel setup to compare the effects of constant (mean) temperatures, most commonly used in experiments, block schemes and natural sinusoidal fluctuations as well as an extreme variant with twice its amplitude using the cosmopolitan mosquito species *Culex pipiens* s.l. as a study organism. Our system accurately replicated the preprogrammed temperature treatments under outdoor conditions, even more accurately than traditional methods. While no effects were detected on survival and sex-ratio within the ranges of variation evaluated, development was sped up considerably by including temperature fluctuations, especially during pupation, where development under constant temperatures took almost a week (30%) longer than under natural fluctuations. Doubling the amplitude further decreased development time by 1.5 days. These results highlight the importance of including (natural) oscillations in experiments on ectotherm organisms – both aquatic and terrestrial – that use temperature as a variable. Ultimately, these results have major repercussions for downstream effects at larger scales that may be studied with applications such as ecological niche models, disease risk models and assessing ecosystem services that rely on ectotherm organisms.

**Keywords:** Arduino, *Culex pipiens*, heat wave, larval development, mesocosm, microcontroller, mosquito, temperature fluctuations.

### 3.1 Introduction

Temperature is commonly acknowledged as one of the primary forces driving ectotherm populations (Mellanby and Gardiner 1997; Newell 1966). Temperature influences metabolic rates at cellular and subsequently organismic level (Kuznetsov et al. 2016) as a result of differences in optimal temperatures for different enzymatic reactions (Rao and Bullock 1954). In extreme cases, survival might be affected, as a result of denaturation and impaired membrane function (Bowler 2018). Experiments using temperature are of major importance to predict the effects of large-scale disturbances like climate change on these organisms.

Global warming affects not only daily mean temperature, but also the daily interval in temperature (Colinet et al. 2015; Easterling et al. 1997; Paaijmans et al. 2013). Additionally, effects on a local scale exist, wherein effects like urban heat islands affect diurnal and seasonal temperature fluctuations. Various studies suggest that indeed the diurnal amplitude also might affect the development of ectotherm organisms (Kern, Cramp, and Franklin 2015; Kingsolver, Higgins, and Augustine 2015; Kuznetsov et al. 2016; Ludwig and Cable 1933; Waqas et al. 2020), possibly via temperature dependent processes such as growth and cell differentiation (van der Have and de Jong 1996; Ratte 1984). Similar, and possibly sex-specific effects (Agnew, Haussy, and Michalakis 2000; Alcalay et al. 2018), have been detected for mosquito vectors (Colinet et al. 2015; De Majo et al. 2019; Headlee 1941; Huffaker 1944; Ratte 1984), which undergo their subadult development in shallow (often temporary) water bodies where drastic temperature changes are common. To understand how to manage such anthropogenic impacts, it is thus crucial to understand the exact effects of temperature fluctuations on arthropod vector development. However, a small-scale and inexpensive experimental system to do so was until recently unavailable (Hagstrum and Hagstrum 1970; Hermann et al. 2022).

Most ecological experimental studies including temperature as a variable (i.e., micro- and mesocosms) have hitherto been dependent on decentralized temperature regimes in climate cabinets (Greenspan et al. 2016; Hagstrum and Hagstrum 1970) or with heating elements set to a constant temperature (Bayoh and Lindsay 2004; Brust and Kalpage 1967; Impoinvil et al. 2007; Shapiro, Whitehead, and Thomas 2017; Shelton 1973). The latter system occasionally has been adapted to a block scheme, where temperatures fluctuate between two levels that are fixed over a set amount of time (Alcalay et al. 2018; Spanoudis et al. 2019) or by physically moving the study organism between climate chambers

(Niederegger, Pastushek, and Mall 2010). However, the widespread availability of micro-controllers (Bolanakis 2019) allow for a well replicated assessment of the relative importance of thermal variation.

To better understand the precise effects of temperature on ectotherm development, we developed an inexpensive, easily reproducible, and open-source Arduino-based temperature control system. This setup allows for emulation of natural sinusoidal fluctuations above ambient temperatures whilst keeping the number of degree-days over all treatments the same. Here, as a case study to validate the metabolic effects, we compared the effects of commonly used constant (mean) temperature and block schemes with natural sinusoidal fluctuations, as well as an extreme regime with twice its amplitude. We used the mosquito species *Culex pipiens* (hereafter *Cx. pipiens*), a cosmopolitan vector for a range of viral pathogens including West Nile virus, Sindbis virus and Usutu, as a model species. As the subadult stages of this species are aquatic, this allows for easy implementation of temperature regimes via immersible heating elements.

## 3.2 Materials and methods

To study the effects of natural temperature oscillations on metabolic rates in aquatic systems, we used the following procedure.

### 3.2.1 Temperature control system

Our novel temperature control system (holistic intermittent heatwave instrument; hereafter HIHI) for investigating the effects of temperature fluctuations is comprised of a closed container to hold the electronics, a power supply, the internal electronics, and relay-controlled power strips. The setup allows for up to eight groups of heaters to be connected per HIHI, for a total of 10 Ampère per group. Using 200W heaters, this translates to 80 mesocosms in total.

#### 3.2.1.1 Container

As the HIHI may be used outdoors, care was taken to protect the electronic components and their connections from rain/humidity whilst preventing build-up of heat. Two polycarbonate storage boxes were used to house the electronic components, one for the microcontroller and relay board, and one for the power strips and their connection to the heaters. Holes were cut into the bottom of both boxes for ventilation, and into the overhang of the lid to allow wires to pass through. The cables were glued in place with hot glue to prevent moisture from entering. To allow for sufficient air supply, holes were

cut on the bottom of the containers and were placed on a layer of stones to allow for aeration. Placement of the containers was limited by the length of the power cables and cables of the temperature sensors. In our case we placed the containers in the middle of the experimental setup.

### 3.2.1.2 Power supply

HIHI is operated by one 5v micro-USB power supply, which may be connected to a laptop to allow for logging the temperatures from the serial logger included in the Arduino IDE or may be connected to a 1A phone charger. The relay board operates on grid power (240V).

### 3.2.1.3 Control box

The control box internal electronics are shown in Table 3.1 and Figure 3.1. The costs for the electronics are estimated at 49 euro. The programmed temperature is compared to the current surface water temperature, measured by DS18B20 (i-button) sensors (Maxim integrated, San Jose). Based on this information, each treatment is heated or left to (passively) cool via activation or deactivation of the heaters connected via an optocoupled relay with a specified interval.

**Table 3.1** Components for the temperature controller

Component	Quantity	Price (€)	Specifications	Use
Arduino uno	1	24,95		Controls temperature
Temperature sensor	4	4x2,95	DS18B20; minimum of 2 per treatment	Measures temperature
Optocoupler relay module	1	10,00	2ph109375a or equivalent; 240V/10A per relay; 2 channel or more	Turns heaters on or off
Resistors	4	4x0,03	470Ω	Limits current to sensors
perfboard	1	0,70	Size approximately 4x6 cm	To assemble circuit onto
Insulated conductor cable	1	0,60	1m	Connects components
Female header pin	1	0,18	1x6 pins	Connector to relay module
	Total price	48,35		

### 3.2.1.4 Relay-controlled power strips

The power strips are driven by opening the live wire and connecting these to the COM and NO connections of their respective relay-group. Heaters were plugged into the power strips. Care was taken to adequately distribute the heaters over multiple relays as not to overload the relay and/or power strip (commonly rated for 10A and 16A, respectively).



### 3.2.1.5 Operational process

The operational procedure that the temperature controller undergoes is specified in Figure 3.1a. The microcontroller can be pre-programmed with user-specified temperature schemes for each time interval (e.g., 1, 2 or 5 minutes). The operational code needed to operate the temperature controller may be downloaded from GitHub and uploaded using the open-source Arduino integrated development environment (Wheat 2011; see data accessibility section). Temperature schemes can be altered to any temperature scheme, for instance real-world thermal regimes captured from environmental data loggers, by changing the temperature arrays. Diurnal temperature fluctuations can be programmed with the “curve calculation” Excel file provided in the dryad repository, by changing the interval, daylength, mean temperature and amplitude and subsequently copying the produced array to the code.

### 3.2.2 Validation tests

Two exploratory studies were performed as generic validation to 1) determine the interval with which the temperature controller should operate and 2) to determine and correct for any bias present in the programmed temperatures. These tests were performed in white polypropylene carbonate 12L buckets (31,6 x 32,5 x 25,5 cm), which were also used for the proof of principle experiment.

#### 3.2.2.1 Interval calculation

The interval for the temperature controller was determined by recording the time needed to either warm or passively cool the 12L bucket by 0.1°C. This was done by taking the average time over 2°C heating/cooling. Using 200W HS-aqua heaters, a 2-minute interval proved sufficient, as this allowed the container to either cool by 0.1°C or to heat up by 0.08°C during the allotted time. From this, a heat transfer coefficient could be derived to predict intervals that may be used for similar setups (surface, volume and humidity) under a range of temperatures as compared to ambient air temperature (Table 3.2).

**Table 3.2** Predicted intervals to cool 0.1°C derived from Newtons law of cooling, a heat transfer coefficient of 623587 W/(m<sup>2</sup>K), a diameter of 32 cm, relative humidity of 68% and variable temperature interval as compared to ambient air temperature.

Temperature difference (°C)	Interval (minutes)
20	0.69
18	0.77
16	0.87
14	1.00
12	1.16
10	1.40
8	1.75
6	2.34
4	3.52
2	7.13

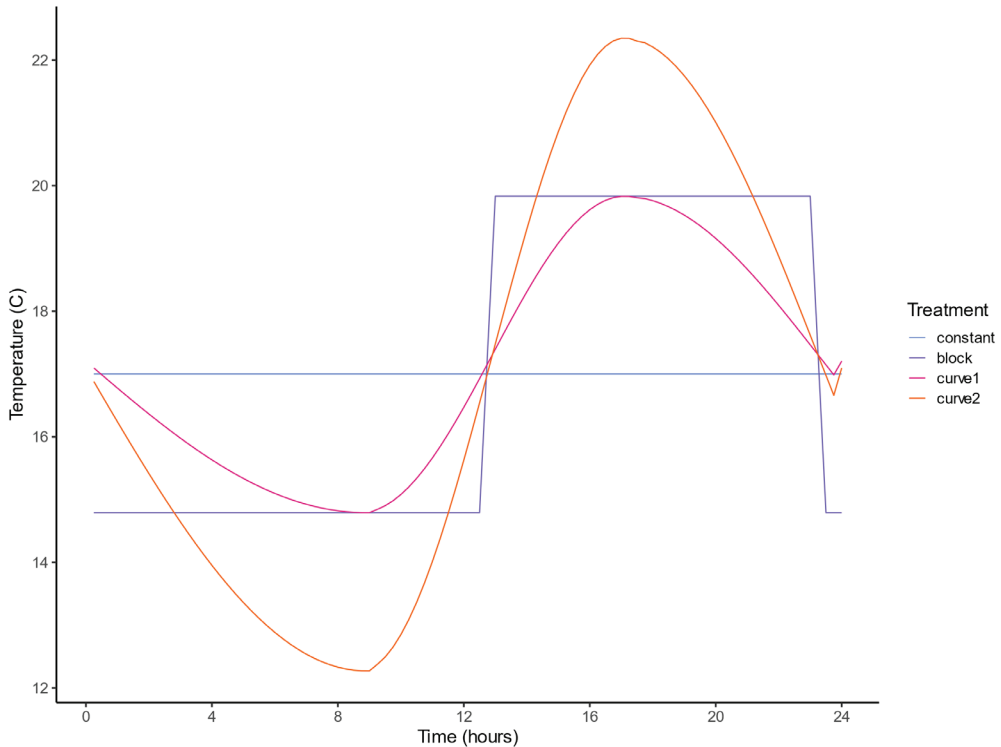
### 3.2.2.2 Bias correction

Adherence to the programmed temperatures specified in section 2.3 was validated by use of a one-day pilot. The setup was allowed to run normally, and the number of degree-days, equal to the sum of the mean temperature per 15 minutes for a 24-hour period, was estimated for each treatment by calculating the approximation of the surface between each (2-minute interval) timepoint as a trapezoid. Using this data, a bias of +0.1C was found, after which the formulas were corrected, and the pilot was run again to validate that the bias had been reduced (supplementary Table S3.1).

### 3.2.3 Temperature treatments

Recent insect development models propose that ectotherm metabolism and development do not respond additively to temperature fluctuations (Wu, Shiao, and Okuyama 2015), and are dependent on a variety of temperatures (Kuznetsov et al. 2016; Ludwig and Cable 1933; Newell 1966; Waqas et al. 2020; Wu et al. 2015) for optimal cell growth and differentiation (van der Have and de Jong 1996; Ratte 1984). This could result in variation across populations as a result of (local) adaptations (Sternberg and Thomas 2014). As to our knowledge an optimum diurnal temperature fluctuation has hitherto not been established for our model species, we chose to simulate as much realism as possible, and thus used temperatures associated with the peak of the mosquito season for our latitude. Because of this we simulate an average day at the peak of the Dutch

mosquito season. To ensure the number of degree days to be consistent across the four treatments of increasing fluctuation, we used the following procedure. Based on aquatic surface temperatures measured in May and July 2020, we determined mean, minimum, maximum temperature, and the temporal interval between these (Supplementary Figure S3.1). These temperature metrics were used to create four treatments with equal mean (Figure 3.2) using the methods described in the operational code (see data availability section).

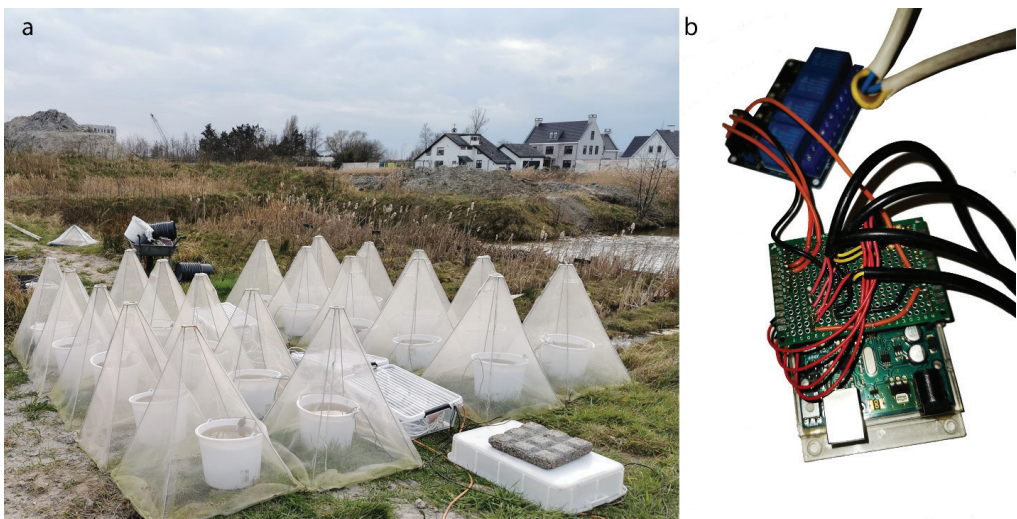


**Figure 3.2** Visual representation of the programmed temperature regimes of increasing levels of temperature fluctuation. The area under the graph – indicative for the amount of energy in the aquatic system – is the same for all treatments. The temperatures mimic an average day in June (2020) in the Netherlands.

#### 3.2.4 Proof of principle experiment

In order to validate the reliability of the proposed system, and the effect of temperature fluctuations on the development and (sex-specific) survival of an ectotherm organism, a proof-of-principle experiment was conducted at the living lab field station of Leiden University, the Netherlands (Boerlijst et al. 2023).

The current experiment used the mosquito *Cx. pipiens* as a model organism. The experiment took place between the end of March and beginning of May of 2021 and took 34 days. As the outside temperatures are relatively low in that period, this allowed us to mimic the natural temperature conditions of an average day in June 2020, because the ambient temperatures sufficiently low to cool down the buckets to the desired temperatures. June is commonly regarded as the optimal month for mosquito development in NW Europe as the amount of sunlight energy, a direct determinant of the water temperature, is at its maximum (Becker et al., 2010). The experiment, containing four temperature treatments (Figure 3.2), had 5 replicates each consisting of white polypropylene carbonate 12L buckets (31,6 × 32,5 × 25,5 cm; Figure 3.3; Supplementary Figure S3.1). The containers are representative of the artificial containers that *Cx. pipiens* is known to colonize (Koenraadt and Harrington 2008). Within these small, temporary water bodies, fluctuation of temperature is highest and there is little competition and predation (Kumar and Hwang 2006).



**Figure 3.3** Overview of the experimental setup. Panel a shows the mesocosms covered by emergence traps and the HHIH and power strips in the middle. Panel b shows the HHIH, with the Arduino and circuit board to the left, and the relay board to the right.

Each bucket was filled with 10 liters of dechlorinated tap water and a standardized community of algae and bacteria, collected with a plankton net (250  $\mu\text{m}$  with a 53  $\mu\text{m}$  collector) from a neighboring lake (Dellar, Boerlijst, and Holmes 2022). The filtered algae and bacteria obtained were divided equally over all containers so that one liter of water in the set-up contained as much microbes as a liter of

ditch water. An eutrophic environment (20 mg/L N-total; Loeb and Verdonschot 2008) was created, using cow manure pellets (2,4% N; 1,5% P<sub>2</sub>O<sub>5</sub>; 3,1% K<sub>2</sub>O) to minimize intraspecific competition (Boerlijst et al. 2023). The buckets were thereafter covered with a 0.1mm mesh to prevent natural colonization and left to acclimatize for one week. 200 first instar larvae were then added to each container and the four treatments were semi-randomly assigned within a Latin square design (Appendix 3). During the experiment, an emergence trap (Cadmus, Pomeranz, and Kraus 2016) was used to prevent colonization, protect the mosquitoes from predators and to prevent the emerged mosquitoes from flying out. Evaporated water was replenished daily using dechlorinated tap water stored at ambient temperature.

Life-stage specific development and sex-specific emergence rates were included as dependent variables. Additionally, dissolved oxygen concentration, turbidity and chlorophyll a concentration were measured as indicators for resource competition due to their relation with bacterial and algal metabolism (Ansa-Asare, Marr, and Cresser 2000; Coolidge 2017).

### 3.2.4.1 Study organism

*Culex pipiens* var. *pipiens* egg rafts were obtained from the rearing facility of Wageningen university, the Netherlands. The larvae were subsequently allowed to hatch in a white plastic bucket containing 10 liters of lake water where they were kept at ambient temperature until the start of the experiment.

### 3.2.4.2 Measurements

The temperature in each mesocosm was recorded every 15 minutes for the duration of the experiment by a temperature logger (iButton DS1921G#F5D) placed 5cm under the water surface to i) measure the temperature near the water surface where mosquito larvae spend most of their time (Becker et al. 2010) and ii) prevent the loggers from emerging due to evaporation. Larval development was measured 5 days a week and time to pupation, time to emergence, survival rate and sex-ratio were determined congruent with the methods of Boerlijst et al, 2022. Dissolved oxygen concentration (DOC), chlorophyll a and turbidity levels were measured weekly with a Hach HD40 and Aquafluor 8000-010, respectively, using manufacturers protocols.

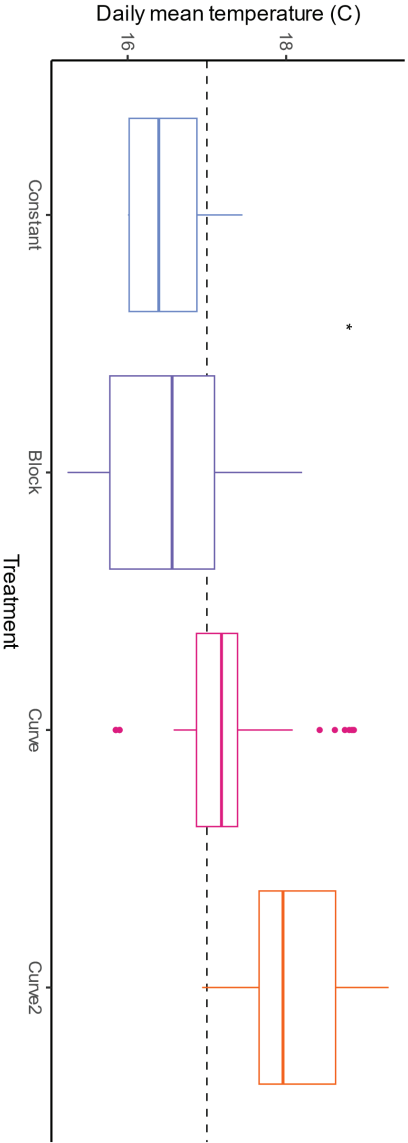
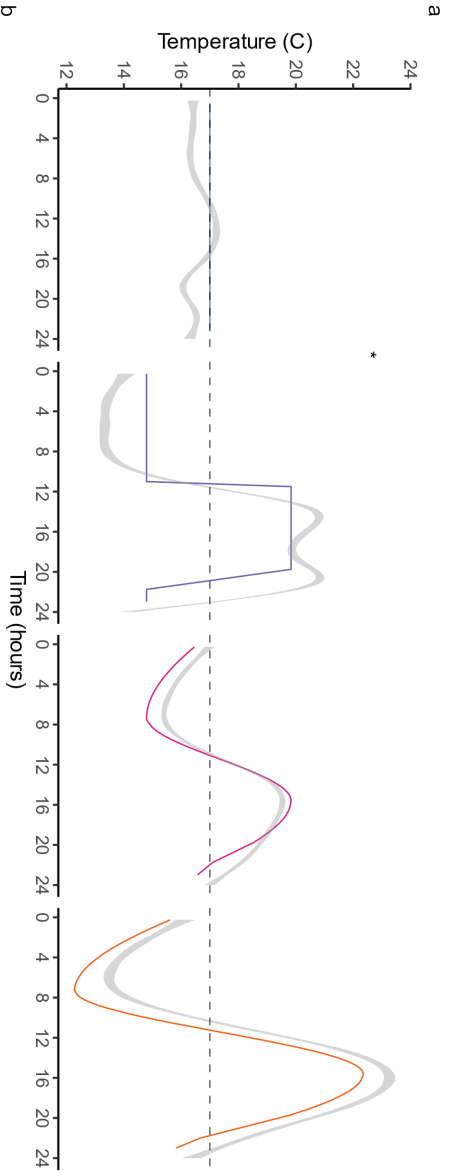
### 3.2.5 Statistical analysis

All data were analyzed in R version 4.04 (R Core Team 2018). To compare the amount of energy per day between the different treatments, we calculated the degree days in unit of hour per day per mesocosm as approximated integral of the iButton measurements with trapezoidal integration from the pracma package (Borchers 2022). Adherence of the treatments to their respective programmed temperatures was analyzed using an ANOVA on a linear mixed effect models with the formula:  $\text{Temperature} \sim \text{time} + \text{predicted temperature} + (1|\text{Cosm}) + (1|\text{Day})$  for the block, curve and curve 2 treatments. As all predicted values for the constant treatment are equal to its mean, we analyzed this treatment using a Wilcoxon rank sum test. The block treatment was analyzed using the (10) days prior to the short circuit of this treatment (Figure 3.4a). Effects on the life-history of the within day variation within the full experiment (Supplementary Figs. S3,4) are described in the discussion. Daily mean temperature for each of the respective treatments was assessed using a two-way ANOVA using the formula  $\text{Degree days} \sim \text{Day} + \text{Treatment} + \text{Day:Treatment}$ . Data from day eight was excluded as a blown fuse within the field facility had disrupted the block and constant treatments.

Differences in time to pupation, time to emergence, survival and sex-ratio were assessed with general linear models comparing the number of emerged mosquitos, average development stage, the number of emerged mosquitoes per sex respectively whilst using DOC, chlorophyll  $\alpha$  and turbidity as main factors. Covariates and their interactions were stepwise removed from the full models during model optimization if not significant and if the Akaike information criterion indicated a worse fit of the data. All full models are presented in supplementary Table S3.2.

## 3.3 Results

To assess the effect of temperature fluctuations on culicid metabolic rate, data was collected on 1) temperature, to allow for comparison with target temperatures and thus HHI accuracy and 2) life-history traits to detect developmental differences across different levels of thermal fluctuation.



**Figure 3.4** Measured temperatures as compared to the programmed temperature regimes of increasing levels of temperature fluctuation. Panel a shows the measured temperatures over time, including standard error, in gray, and the programmed regimes in color. Panel b shows the mean daily temperature in color for the temperature sensors shown in gray. \* subset of first 10 days of the experiment (up to the short circuit of the respective treatment).

### 3.3.1 Temperature series

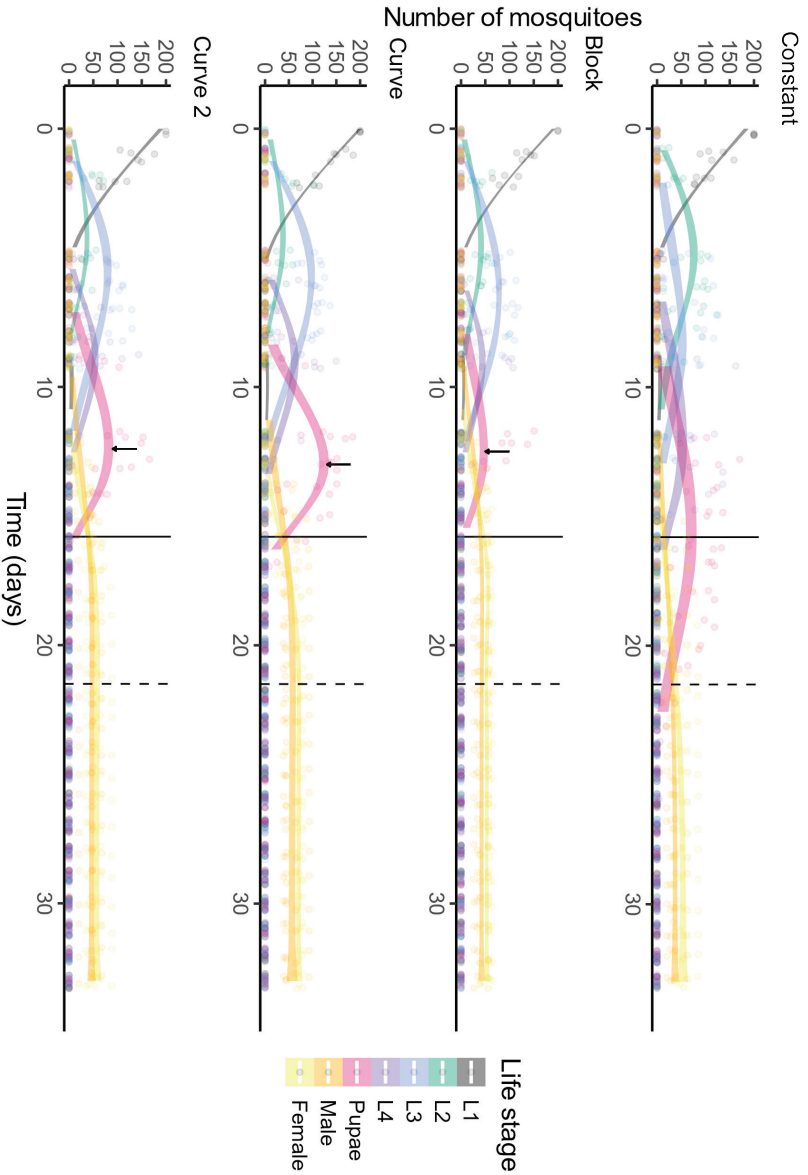
To compare the reliability of our proposed system, we compared predicted and actual temperature measurements per 15 minutes for each treatment (Figure 3.4a). A 0.5°C difference was detected in temperature between the predicted and actual measurements ( $W = 5963$ ,  $p < 0.001$ ). No significant differences were detected for the block ( $F_{1,1} = 0.01$ ,  $p = 0.94$ ), constant ( $F_{1,1} = 0.003$ ,  $p = 0.97$ ), curve ( $F_{1,1} = 0.43$ ,  $p = 0.63$ ) and curve 2 ( $F_{1,1} = 1.63$ ,  $p = 0.42$ ) treatments.

The daily mean temperatures derived from the iButtons were subsequently compared per day across treatments with increasing temperature fluctuation to detect differences in energy input (Figure 3.4b). Differences were detected over time ( $F_{20} = 8.972$ ;  $p < 2e-16$ ; power = 1) across treatments ( $F_3 = 144.66$ ;  $p < 2e-16$ ; power = 1), also interactively ( $F_{60} = 4.759$ ;  $p < 2e-16$ ; power = 1). Post hoc pairwise t-tests indicated differences between Constant and the treatments curve and curve 2 at day 3 and 7 ( $p < 0.05$ ). Further differences were detected between Block and the treatments Constant from day 11 onwards ( $p < 0.05$ ), Curve at day 9-18, 20 and 22 ( $p < 0.05$ ) and curve 2 at day 9 ( $p < 0.05$ ).

### 3.3.2 Life-history effects

Absolute survival rate and sex-ratio were not impacted by different levels of temperature fluctuation within the ranges tested ( $p > 0.1$ ). No differences in DOC, chlorophyll and turbidity were found between the treatments.

Increasing levels of temperature fluctuation decreased development time up to pupation (Figure 3.5). Differences were detected between the constant and curve treatments ( $\chi^2 = 2.017$ ,  $p = 0.022$ ) and the constant and curve 2 treatments ( $\chi^2 = 2.711$ ,  $Df = 3$ ,  $p = 0.003$ ). Increasing levels of temperature fluctuations also lowered time to emergence ( $F(3, 14) = 230.7$ ,  $p < 0.001$ , partial  $\omega^2 = 0.833$ , power = 1). Post hoc analysis indicated differences between the constant treatment and all other treatments ( $P < 0.001$ , Bonferroni correction) and between the block and curve treatments ( $p < 0.05$ , Bonferroni correction). Differences in development time exacerbated during pupation (Figure 3.5, Supplementary Figures. S3.5-6, Table 3.3).



**Figure 3.5** Counts per life stage for constant, block, curve and curve 2. As mortality over time was not measured, the sum of the life stages at each timepoint has been assumed to be equal to the total number of emerged adults for each respective container, except for day 0, which is equal to the starting density. Subsequently, for visualization purposes, all mortality is assumed to occur between day 0 and 1. Median time to pupation and 95% pupation in the control treatment are indicated by solid and dashed lines respectively. Median time to pupation in the other treatments are indicated by a purple arrow.

**Table 3.3** Differences in median time to pupation ( $\Delta TTP$ ) and median time to emergence ( $\Delta TTE$ ) for each contrasting treatment. Increase/decrease indicates whether differences enlarged or reduced during pupation.

Treatment	$\Delta TTP$ (days)	$\Delta TTE$ (days)	$\Delta TTE - \Delta TTP$ (days)	$\Delta TTE / \Delta TTP$ (%)	Increase / decrease
Block – Constant	-2.4	-7.3	-4.8	291	Increase
Block – Curve	-0.5	-2.2	-1.7	440	Increase
Block – Curve 2	0.2	-0.6	-0.8	-300	Decrease
Constant – Curve	2.0	5.1	3.1	253	Increase
Constant – Curve 2	2.6	6.7	4.0	247	Increase
Curve – Curve 2	0.7	1.6	0.9	229	Increase

### 3.4 Discussion

Here we developed a system to assess the effect of thermal fluctuations on ectotherm metabolic rate. Our HIHI system accurately replicated the preprogrammed temperature treatments under outdoor conditions. Comparatively, it performs even more accurately than the traditional Constant and Block regimes, which tend to overshoot and overcompensate due to the thermostat its accuracy of approximately one degree Celsius (Figure 3.4a) as compared to the 0.5 degrees Celsius accuracy of the temperature sensor in the proposed setup. The new system was successfully applied to assess the impact of temperature fluctuations on the development of *Culex* mosquito larvae.

Fluctuations in temperature in our proof-of-principle study had large effects on larval development time, in line with recent models of insect development (Colinet et al. 2015; Kuznetsov et al. 2016; Vajedsamiei et al. 2021; Waqas et al. 2020; Wu et al. 2015), but we did not detect any effect on survival or sex-ratio. Median time to pupation decreased with increasing levels of fluctuation from 16 to 13 days. This effect became even larger during pupation itself with median time to emergence ranging from 22 to 14 days. This is in line with the notion of Kingsolver et al. (2015), that the effect of temperature fluctuations varies across developmental stages. Natural (curve) temperature fluctuations resulted in an average decrease of 7 days (or a third of the development time), as compared to constant temperatures. For both time to pupation and time to emergence, most of the differences in development appear when comparing the constant to natural levels of fluctuation. When comparing Constant to Curve2, thus doubling the amplitude, development decreased by another 1.5 days. Development under the block treatment resembled the natural fluctuation remarkably well, which might partially be explained by the deviation from the preprogrammed mean temperature and occasionally higher amplitude as a result of the short circuit for this treatment after the first 10 days (Supplementary Figs. 3,4). However, the effects of the treatment surpass the change in development rate that might be explained by just a 2°C increase alone (Loetti, Schweigmann, and Burrioni 2011), which suggests that there are additional biological processes at play, with life-stage specific effects.

The remarkable difference during the pupation phase sheds light on the required additional biological explanation. Pupae solely metamorphose, as their pupal enclosure only allows for respiration, not feeding (Becker et al. 2010). This indicates

that interaction with their environment is limited during this stage. As such, the difference in development time with different temperature fluctuations during this life stage is largely internally regulated. Although temperature fluctuations have been described to affect metamorphosis disproportionately (Banahene et al. 2018; Niederegger et al. 2010), we hypothesize that larval stages might be more severely affected than currently visible. During the stages prior to metamorphosis, by other interactions with the environment (competition, food availability, etc.), because of which could mask the effect of thermal fluctuations is less noticeable. Below we elaborate on the possible biological processes underlying the effects of temperature fluctuations on metabolic rate.

Plastic responses to thermal stress, as a part of environmentally induced phenotypic change (plasticity), have been previously described in other ectotherm organisms to be correlated to gene activation, sometimes leading to life-stage-specific tolerances (Belén Arias, Josefina Poupin, and Lardies 2011). Although some gene-specific responses and adaptations are documented (Clark and Worland 2008), there is a very poor understanding of system-wide responses (Gracey et al. 2004). It might be assumed that combined with enzymatic activity (Rao and Bullock 1954), adaptations like gene-activation and its effect on metabolic rate might make development under (natural) variable temperatures more favorable. The exact *modus operandi* behind this pattern, and the relative importance of temperature and genetic dependence on temperature fluctuations, however, remains unknown and requires further study.

Overall, our results strongly suggest that including thermal oscillations in experiments likely results in substantial differences in estimations of key life history parameters (e.g. development time), in our case for mosquitoes. Based on a large body of historical (pre-1970's) as well as more recent literature, there are good reasons to believe that our results are highly similar to those of a large range of ectotherm organisms (De Majo et al. 2019; Hall and Warner 2020; Kuznetsov et al. 2016; Newell 1966; Spanoudis et al. 2019; Waqas et al. 2020; Wu et al. 2015). We speculate that the reason for this is that developmental mechanisms are highly conserved. As such, temperature fluctuations, and systematic impacts thereon – like climate change and urban heat islands – should be considered in experimental work determining the effects of temperature and its interactions. Given that development time of multiple other ectotherm organisms has been shown to be affected by fluctuating temperatures, these findings may have implications ranging far beyond those for mosquitoes.

Our novel temperature control system (HIHI) allows for a crucial step, when aiming to include ecological realism in experimental setups. Our system provides an economic means to simulate natural fluctuations under field-like conditions above ambient temperature and provides a major improvement as compared to currently used systems. A remaining question is whether further steps need be taken when emulating climatic conditions. Fluctuations at different mean temperatures have been described to affect ectotherm organisms non-linearly (De Majo et al. 2019; Kingsolver et al. 2015; Wu et al. 2015), with species specific optimal means (Niederegger et al. 2010). As such there is a need to implement thermal fluctuations in experiments on for instance the effects of heat spikes and more complex fluctuations (Greenspan et al. 2016) on (potentially sex-specific) mortality and assessing severeness of metabolic effects in other organisms. These alterations could be implemented by simply adapting the temperatures within the code. When doing this, we urge future users to verify the interval using a similar pilot as in section 2.2.1 as passive cooling is dependent on a multitude of variables including, but not limited to, ambient temperature, humidity and volume/surface ratio. The current setup does not allow for active cooling as such equipment is costly and likely introduces significant additional disturbance. Therefore, without adaptations, the current setup is limited to temperature regimes above ambient temperatures, or experiments using phenological forcing. Regions with distinct seasonal temperature variations may thus be better suited for the proposed equipment in its current form. As such, alterations would be necessary if cooling below ambient temperature is desired. For instance, by circulating of cooling water via heat exchangers or using a jacketed mesocosm (Potter 2023; Silverberg, Gagnon, and Lee 1995). Alternatively, ambient heating could be minimized by using shading cloth (Schrama et al. 2018; Sukiato et al. 2019). Adaptation to terrestrial setups might be preferable, which can be done similar to the works of Cheng et al. (2011) and Greenspan et al. (2016) i.e. by introducing a humidity sensor and ultrasonic transducer. Similarly, more complex systems should be considered to assess, incorporating interactive effects related to water flow of e.g., presence of organic matter, salinity, vegetation, etc. As such our tool provides a reliable and cost-effective means for a broad range of applications.

---

## Acknowledgements

Pieter Rouweler & Sander Koenraadt are gratefully acknowledged for supplying mosquitoes from the Wageningen University rearing facility. Many thanks to Anne Ummels for her help with the data collection. Martha Dellar, Gertjan Geerling and Louie Krol are thanked for their help during internal review.

## Authors' contributions

SB and MS conceived the general idea for the equipment and experiment. Design and development were done by SB. Data collection was performed by SB assisted by MS. EB, MS and PB assisted with the writing of the manuscript. All authors read and approved the final manuscript.

## Data Availability

The data supporting the findings of this study, R-script and the operational code are available from the Zenodo repository: <https://zenodo.org/doi/10.5281/zenodo.10724529>. Build instructions are available within the article its supplementary materials.

## Funding

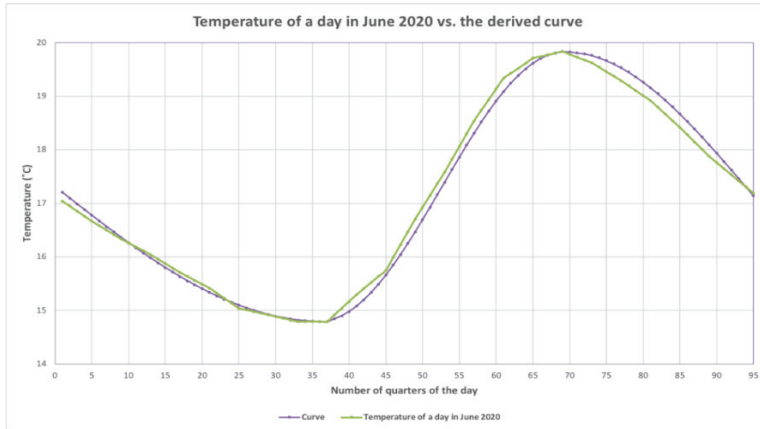
This publication is part of the project 'Preparing for vector-borne virus outbreaks in a changing world: a One Health Approach' (NWA.1160.1S.210) which is (partly) financed by the Dutch Research Council (NWO).

## Conflict of Interest statement

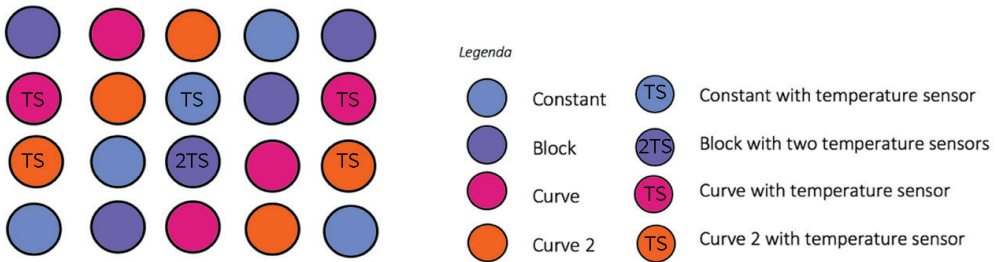
The authors declare that they have no competing interests.

## Supplementary information

### Section 1 Supplementary figures and tables



**Figure S3.1** Average surface water temperature of a day in June 2020 at the experimental site (green). From this data a sinusoidal curve was constructed using the day-length, mean, minimum, maximum temperature, and interval (purple).



**Figure S3.2** Overview of the experimental design. The circles show the containers with treatments with increasing temperature fluctuation. There was one-meter distance between all containers. The temperature sensors indicate DS18B20 sensors used in real time by the HIHI (for Curve and Curve2) or thermostat (for Constant and Block) to activate/deactivate the heaters per treatment.

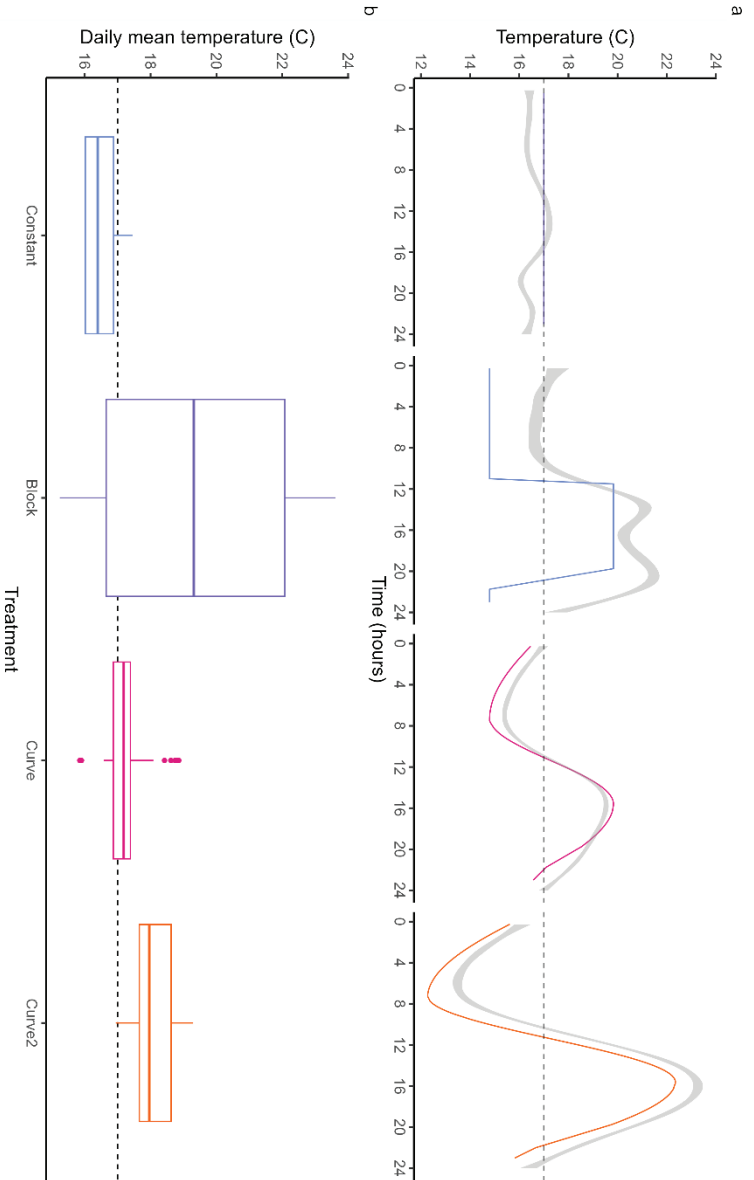
**Table S3.1** Proportion of degree days in each of the treatments during the calibration pilot

Treatment	Prior to calibration		After calibration	
	Degree-days	Proportion respective to constant (%)	Degree-days	Proportion respective to constant (%)
Constant	741.77	100.0	894.05	100.0
Curve 1	753.58	101.6	896.03	100.2
Curve 2	766.45	103.3	885.20	99.0

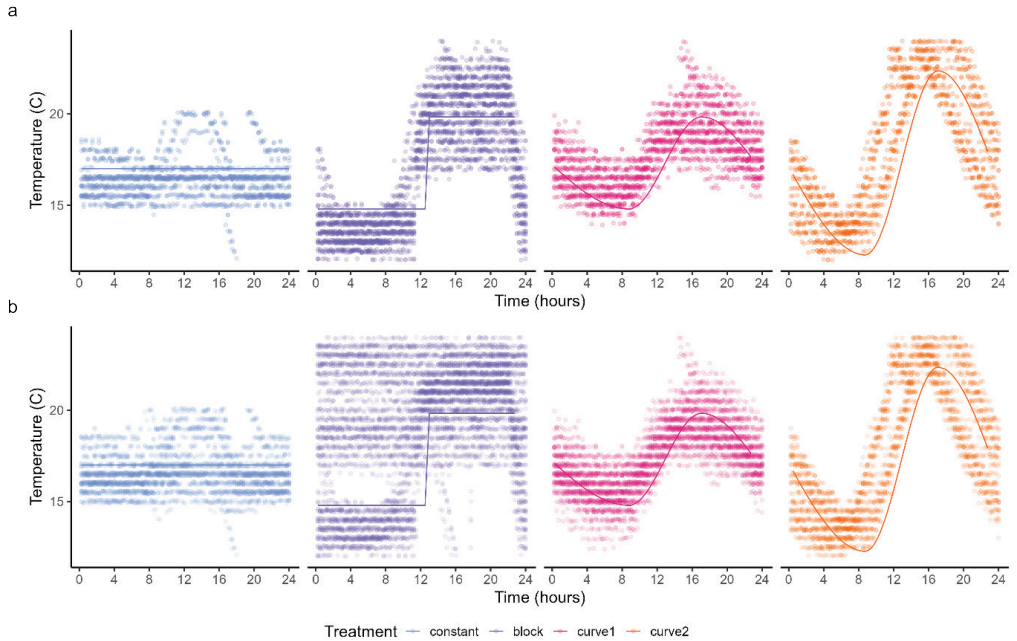
**Table S3.2** Estimated regression coefficients and standard errors for each of the tests

Population Parameter	Formula	Treatment	Estimate	Std. Error	t value	Pr(> t )
Survival rate	survival_rate ~ Treatment	(Intercept)	118.4	9.486569	12.4808025	1.16E-09
		Block	6.6	13.416035	0.4919486	6.29E-01
		Curve	25.2	13.416035	1.8783493	7.87E-02
		Curve2	10.2	13.416035	0.7602842	4.58E-01
Sex ratio	sex ratio ~ Treatment	(Intercept)	0.97788	0.1040257	9.40E+00	1.12E-07
		Block	0.16664	0.1471145	1.13E+00	2.75E-01
		Curve	0.17644	0.1471145	1.20E+00	2.49E-01
		Curve2	0.090245	1.56E-01	0.5783508	5.72E-01
Time to pupation	TTP ~ Treatment	(Intercept)	13.6	5.92E-01	22.988	1.11E-13
		Block	-0.6	8.37E-01	-0.717	4.84E-01
		Curve	-1.8	8.37E-01	-2.151	4.71E-02
		Curve2	-2.6	0.8367	-3.11E+00	0.00677
Time to emergence	TTE ~Treatment	(Intercept)	21.666667	0.6374553	33.989314	7.43E-15
		Block	-7.266667	0.8063242	-9.01209	3.33E-07
		Curve	-5.066667	0.8063242	-6.283659	2.01E-05
		Curve2	-6.666667	0.8063242	-8.267973	9.31E-07

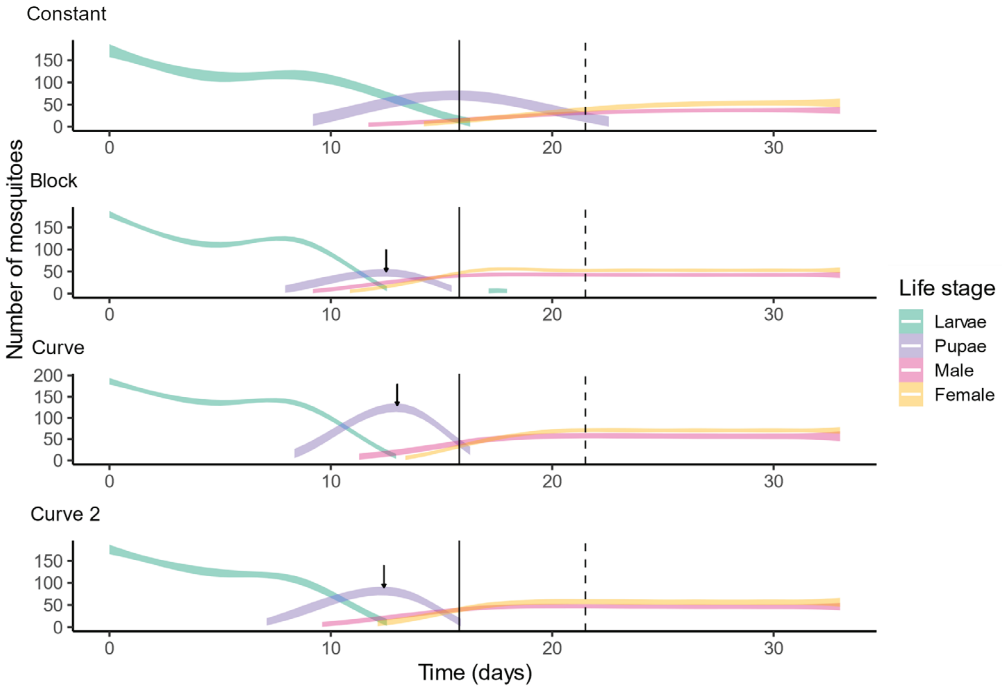




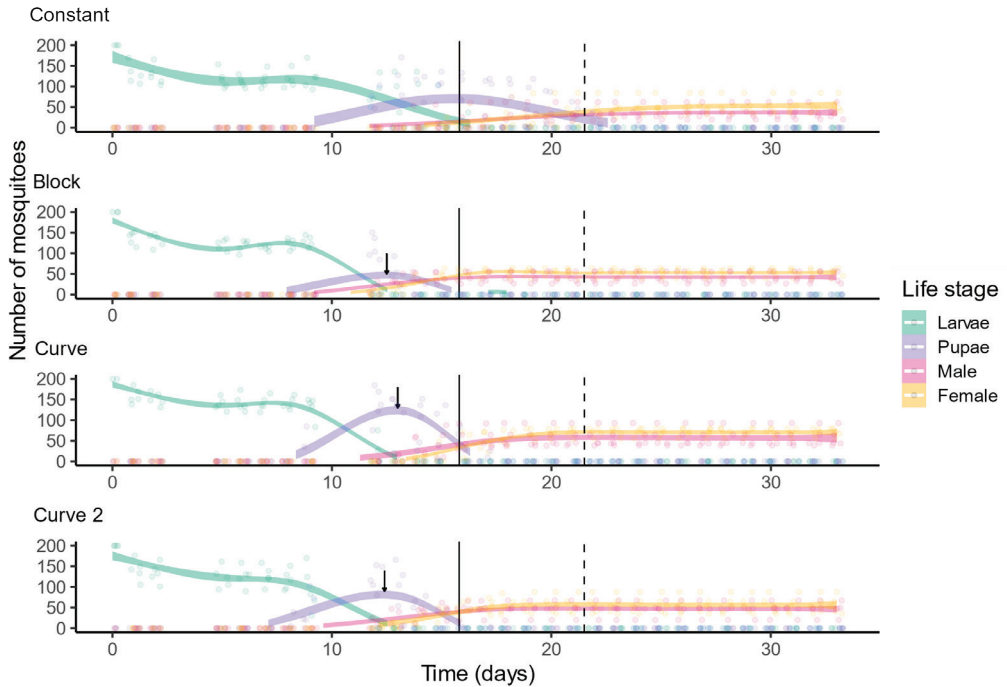
**Figure S3.3** Measured temperatures as compared to the programmed temperatures over time for daily fluctuation regimes of increasing levels of fluctuation for the entire duration of the experiment. Panel a shows the measured temperatures over time with standard error in gray and the programmed regimes in color. Panel b shows the mean daily temperature in color with the standard error ( $\pm 0.5$ ) for the temperature sensors shown in gray.



**Figure S3.4** Raw data of measured temperatures as compared to the programmed temperatures over time for the daily fluctuation regimes of increasing levels of fluctuation. Panel a shows the measured temperatures over time and the programmed regimes in as lines up to the short circuit. Panel b shows the measured temperatures over time and the programmed regimes as lines for the entire duration of the experiment.



**Figure S3.5** Counts per life stage for constant, block, curve 1 and curve 2. The proportion of the life stages at each timepoint has been extrapolated to the total number of emerged adults for each respective container. As mortality over time was not measured, the sum of the life stages at each timepoint has been assumed to be equal to the total number of emerged adults for each respective container, except for day 0, which is equal to the starting density. Subsequently, for visualization purposes, all mortality is assumed to occur between day 0 and 1. Median time to pupation and 95% pupation in the control treatment are indicated by solid and dashed lines respectively. Median time to pupation in the other treatments are indicated by a red arrow.

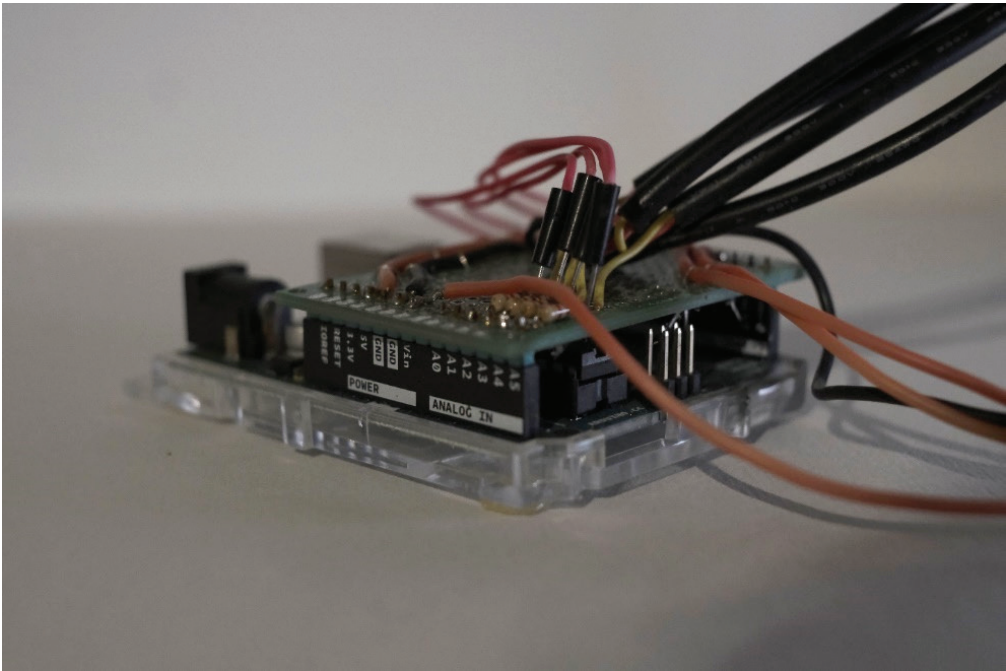


**Figure S3.6** Counts per life stage for constant block, curve 1 and curve 2. As mortality over time was not measured, the sum of the life stages at each timepoint has been assumed to be equal to the total number of emerged adults for each respective container. As mortality over time was not measured, the sum of the life stages at each timepoint has been assumed to be equal to the total number of emerged adults for each respective container, except for day 0, which is equal to the starting density. Subsequently, for visualization purposes, all mortality is assumed to occur between day 0 and 1. Median time to pupation and 95% pupation in the control treatment are indicated by solid and dashed lines respectively. Median time to pupation in the other treatments are indicated by a purple arrow.

**Section 2** *Build instructions H1H1*

The following are building instructions for the temperature control module. The module consists of two groups of connections. First, the incoming signals, from the temperature sensors, connected to a common ground (black) and 5V (red), and each a separate digital pin (D8-12) for their signal (yellow). Secondly, the outgoing signal, going to the relay board. The relay board is powered by the Vin (red) and is driven by two data lines from digital pin 3 and 4 activating and deactivating the relays. The relay board is connected using female header pins for easy storage. Optionally, the control module can be mounted on the Arduino like a shield using male header pins.

3



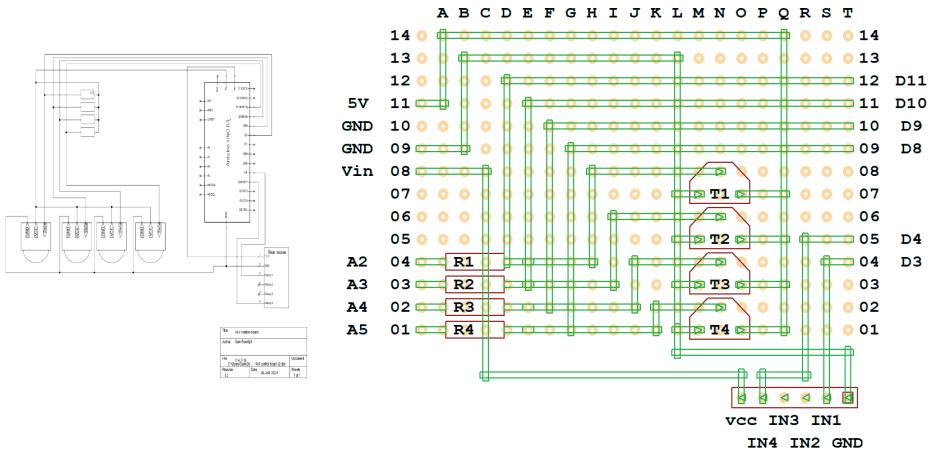
**Figure S3.8** *Overview of the temperature control module*

Step 1. Components list

- Arduino uno
- DS18B20 temperature sensor (4x)
- 4 Channel octocoupler relay interface board (e.g. 2ph109375a)
- Resistors 470  $\Omega$  (4x)
- perfboard
- Red and black insulated wire (approx. 50cm each)
- Soldering iron and solder
- Female header pin 1x6; as connector to the relay board
- Optional: male header pin (1x14 and 1x8 as shown or 1x1 for each of the four corners; to mount the PCB to the Arduino)
- Optional: 20cm metal wire (for cable management and to secure the wires to the relay module)



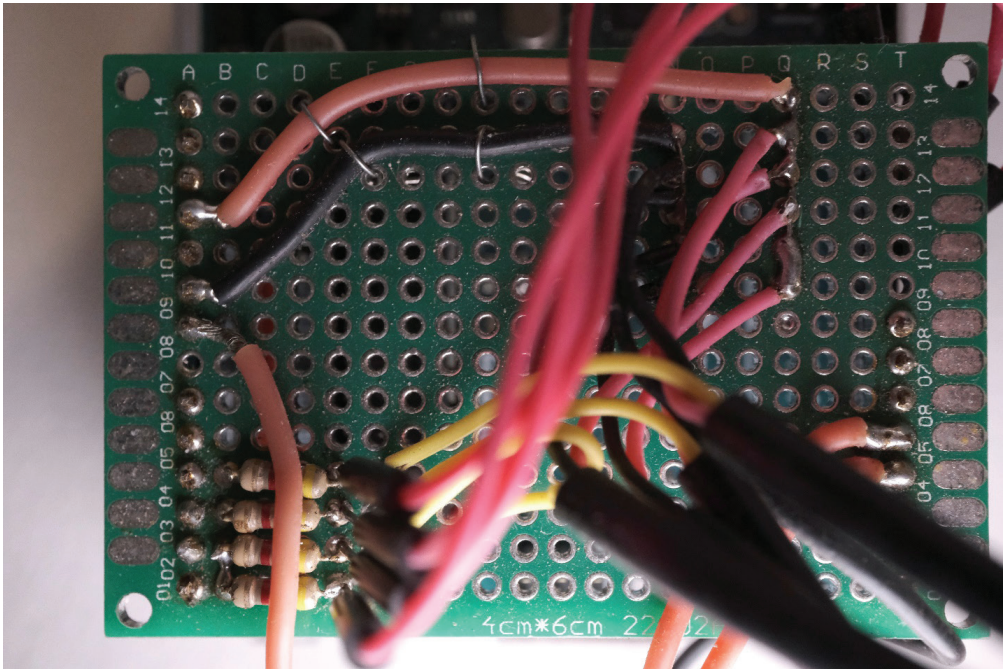
Step 2. Circuit diagram



**Figure S3.9** Schematic overview of the temperature control module, with a circuit diagram (left) and an example of the corresponding physical layout (right).

### Step 3. Building process

- Insert all components into the perf board in a similar arrangement to the circuit diagram (Figure S8) and bend the legs to prevent them from falling out.
- Optionally, insert the header pins into unused connections on the Arduino. Lay the PCB on top so that it rests flat on the header pins.
- Connect all wires:
  - o Relay module: Vin - 12V, GND – GND, D3 – Relay 1, D4 – Relay 2
  - o Sensor1: GND – GND, 5V – VCC, D8 & R1 – Data
  - o Sensor2: GND – GND, 5V – VCC, D9 & R2 – Data
  - o Sensor3: GND – GND, 5V – VCC, D10 & R3 – Data
  - o Sensor4: GND – GND, 5V – VCC, D11 & R4 – Data
  - o Resistors: 5V – R1 & R2 & R3 & R4
- Solder the connections alternating between components, so that they can cool sufficiently.
- Optionally, cut the metal wire into 4cm strands and secure the wires leading to the relay module at the bottom of the control unit, so that stress on the wires will not damage the solder joint. You may use any remaining wire for cable management.
- Insert the female header pins into the relay module (Figure S3.11) and solder the respective wires in place. Take care not to heat each connection for too long as this may cause the plastic to melt.

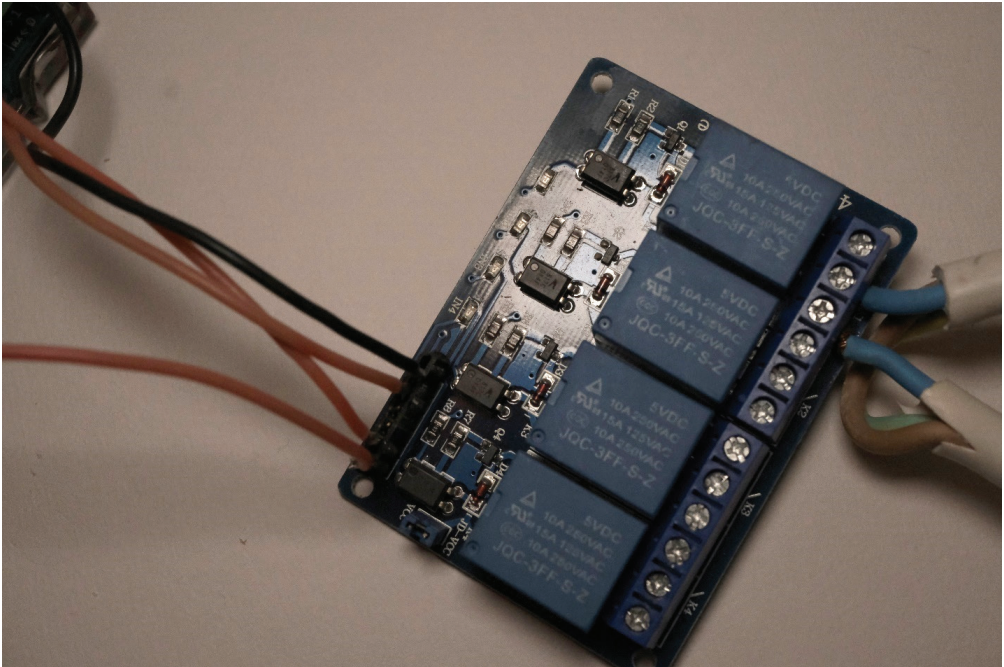


**Figure S3.10** Overview of the control module.

Connections are indicated using the perf board its indices from A-T (left-right) and 1-14 (bottom-top). The ground (A9) and 5v (A11) connections are split across the temperature sensors at the top (N9-13, Q9-14). Their data lines in yellow at the bottom left (E1-5) are connected directly to digital pins 8-12 at the top right (T11-14), and via resistors at the bottom left (B1-5) to the 5v connector (via the underside of the board; B11). The relay module is powered by the Vin (B8) and ground (N9) and driven by digital pins 3 and 4 of the Arduino (T4,5).

### Step 4 Connect the power strips

- Using a set of pliers, remove 3cm of the outer insulation of each power strip, at roughly 10cm from the plug.
- Cut the blue wire and strip 1cm of insulation of each end.
- Screw open the common and normally closed ports of the respective relays, insert one end of the blue wire into each of the ports and screw the ports shut to secure the wire.



**Figure S3.11** Overview of the relay module.

The input from the control board (left) consists of (from top to bottom) the ground in black, data line relay 1 in red, data line relay 4 in red and 5v in red. The output to the power strip (right), here shown for relay 1, is connected to the common (middle) and normally closed (NC; bottom) port of the relay.

### Step 5. Upload the script

Connect the Arduino using the supplied USB connector to your computer and upload the script using Arduino IDE.

Step 6. Check functionality

- Prepare a glass of cold water
- Power the Arduino.
- Take the temperature sensors into your hand and heat them up to body temperature.
- Confirm that the relays open by auditory (hearing the relay 'click') and visual cues (using the led indicator).
- Drop the sensors into the cold water
- Confirm that the relays close by auditory (hearing the relay 'click') and visual cues (using the led indicator).



A sample of house mosquito adults within an aspirator

## Chapter 4

### **Taking it with a grain of salt:**

*tolerance to increasing salinization in Culex pipiens  
(Diptera: Culicidae) across a low-lying delta*



*Parasites & Vectors (2024)*  
DOI: 10.1186/s13071-024-06268-8.

Sam P. Boerlijst, Antje van der Gaast, Lisa M.W. Adema,  
Roderick W. Bouman, Eline Boelee, Peter M. van Bodegom  
and Maarten Schrama



## Abstract

Salinity, exacerbated by rising sea levels, is a critical environmental cue affecting freshwater ecosystems. Predicting ecosystem structure in reaction to such changes and their implications for the geographic distribution of arthropod disease vectors requires further insights into the plasticity and adaptability of lower trophic level species in freshwater systems. Our study investigated whether mosquito populations of *Culex pipiens*, typically considered sensitive to salt, have adapted due to gradual exposure. Mesocosm experiments were conducted to evaluate responses in life history traits to increasing levels of salinity in three populations along a gradient perpendicular to the North Sea coast. Salt concentrations up to the brackish-marine transition zone (8 g/L chloride) were used, upon which no survival was expected. To determine how this process affects oviposition, a colonization experiment was performed by exposing the coastal population to the same concentrations. While concentrations up to the currently described LD50 (4 g/L) were surprisingly favored during egg laying, even the treatment with the highest salt concentration was incidentally colonized. Differences in development rates among populations were observed, yet the influence of salinity was evident only at 4 g/L and higher, resulting in only a one-day delay. Mortality rates were lower than expected, only reaching 20% for coastal and inland populations and 41% for the intermediate population at the highest salinity. Sex ratios remained unaffected across the tested range. The high tolerance to salinity for all key life-history parameters across populations suggests that *Culex pipiens* is unlikely to shift its distribution in the foreseeable future, with potential implications for the disease risk of associated pathogens.

**Keywords:** Adaptation; *Culex pipiens*; Environmental change; Mosquito; Population dynamics; Oviposition experiments; Salinization

## 4.1 Introduction

Salinization of fresh water in coastal areas, especially in low-lying deltas, is a natural process that is currently exacerbated by anthropogenic drivers, such as climate change-induced sea level rise, land subsidence and saline ground water seepage, strengthened by the removal of overlying freshwater (van Baaren & Oude Essink, 2009). Saltwater infiltration is commonly acknowledged to negatively affect agricultural yield and freshwater ecosystem services (Bonte & Zwolsman, 2010). The underlying physical processes of salinization are relatively well described (Khan et al., 2011; Lassiter, 2021), and animal diversity at large is understood to decrease under transitory conditions (Telesh et al., 2013). However, little is known about the direct and indirect effects of salinization on animal populations inhabiting (currently freshwater) ecosystems in deltas, especially for species that are disease vectors.

4 The cosmopolitan house mosquito *Culex pipiens* species complex is a known vector for a variety of pathogens, including West Nile virus, Usutu and avian malaria (Bravo-Barriga et al., 2016; Gutiérrez-López et al., 2016; Hubálek, 2008; Kazlauskienė et al., 2013). It has a wide habitat tolerance, ranging from clean rainwater-filled containers to strongly polluted temporal waterbodies, such as ground puddles, and even manure tanks (Becker et al., 2013; Rejmánková et al., 2013). Similar to other mosquito larvae typically associated with freshwater, it accumulates organic osmolytes to combat ionic pressure instead of active ion transport (Chown & Nicolson, 2004) and is known to be quite vulnerable to changes in salinization relative to other mosquito species (Abou-Attia et al., 2000; Kenawy et al., 2013; Kengne et al., 2019) with a median lethal dose (LD50) of 4 g/L and a lethal dose (LD100) of 6-10 g/L chloride for acute salinity stress (Brown & Platzer, 1978; Chidester, 1916; Kengne et al., 2019).

Although a variety of responses to salinization exist among invertebrates (Chown & Nicolson, 2004), general trends exist in the whole invertebrate community. Salinization has been shown to shape insect community structures, negatively affecting diversity (Bleich et al., 2011; Silberbush et al., 2005) via decreased food availability (Ersoy et al., 2022; van Dijk et al., 2019). Although mosquitoes have previously been described to react quite similarly (Balasubramanian et al., 2019; Telesh et al., 2013), it has also been hypothesized that their short generation time (when compared to that of many other macrofauna species, including

their predators (Verberk et al., 2008)) might enable mosquitoes to adapt faster (Carlson et al., 2014; Martin & Palumbi, 1993; Thomas et al., 2010). This could subsequently cause a relative increase in population size in transitory systems due to the alleviation of predation pressure and the relative increase in food resources (Silberbush et al., 2005). Such a fast adaptation rate is observed for a variety of other stressors, such as pesticides (Hamdan et al., 2005; Nazni et al., 2005; Ser & Cetin, 2019). These adaptations are similar to the response to salinization, i.e., by affecting the excretion of harmful compounds (Asakura, 1980; Chown & Nicolson, 2004). This renders it likely that mosquitoes are better able to adapt to increasing salinity than other insect species.

Salinization affects mosquito habitat quality and may thus lower larval survival. However, this depends on how well the larvae are adapted to temporary (i.e., flooding) and continuous salinization events and processes, causing species-specific effects (Kengne et al., 2019). These adaptations in osmoregulation include physiological (reduced surface area of anal papillae or active transport of ions) (Akhter et al., 2017, 2017; Donini et al., 2007) and behavioral adaptations (increased metabolism and uptake of organic compounds in hemolymph) (Aly & Dadd, 1989; Bradley, 1987; Bradley & Phillips, 1976; De Brito Arduino et al., 2015; Donini et al., 2007; Patrick & Bradley, 2000), resulting in tolerance that changes across life stages (Mottram et al., 1994) and differ between sexes (Alcalay et al., 2018). Namely, female mosquitoes tend to be less strongly selected for early maturation, which may lead to prolonged exposure to stress as compared to males (Boerlijst et al., 2023). With time, has adaptations to salinization caused species-specific preferences during oviposition (Boerlijst et al., 2023; Navarro et al., 2003; D. M. Roberts & Irving-Bell, 1997; Silberbush et al., 2014), further shaping mosquito community composition.

At the population level, commonly considered intolerant species such as *Culex pipiens* s.l. (hereafter denoted as *Cx. pipiens*) might be affected by salinization in a variety of ways. Salinization might cause i) no change when tolerance via for instance plastic behavior proves sufficient, ii) local extinction of the species if tolerance is insufficient, iii) displacement when unfavorable conditions are perceived during ovipositing, or iv) local adaptation leading to possibly increased tolerance due to gradual, continuous exposure.

This study aimed to evaluate whether (local) adaptation to salinization occurred, by quantifying and comparing the tolerance of *Cx. pipiens* populations along a gradient from coast to inland. We expected increasing levels of adaptation (i.e. lower mortality, more rapid development and a balanced sex-ratio) closer to the coast as a result of gradual exposure. To this end we performed a mesocosm experiment. We varied concentrations from zero to eight grams of chloride per liter with intervals of two grams, i.e., from freshwater to the predicted maximum inland surface water concentration of 7.5 g/L Cl<sup>-</sup> (Delsman et al., 2020), or the brackish-marine transition zone (Dahl, 1956), at almost half the concentration of sea water.

## 4.2 Materials and methods

### 4.2.1 Collection and rearing of experimental populations

*Culex pipiens* egg rafts were collected during the two days prior to the start of an experimental round from one set of naturally colonized black plastic mesocosms in peri-urban areas of the cities of Leiden, Utrecht and Nijmegen, representing coastal (7 km to sea), intermediate (43 km to sea) and inland (108 km to sea) mosquito populations, respectively. All populations were collected at similar altitude (2-5 m asl). For this purpose, the mesocosms were filled with 6 liters of hypertrophic water (100 mg N-total), after which they were placed under tree cover. The larvae were subsequently allowed to hatch in 50 mL Falcon tubes, where they were kept at ambient temperature until the start of the experiment. Previous pilot studies have indicated that this type of experiment attracts *Cx. pipiens* and *Culiseta annulata* only (Boerlijst et al., 2023; Dellar et al., 2022). The collected egg rafts were distinguished from those of *Culiseta annulata* by their difference in size (Chapman et al., 2020; Sames et al., 2005).

### 4.2.2 Experimental setup

The setup consisted of 45 white plastic 12 L mesocosms, each with a 200-Watt aquarium heater. The experiments were conducted under standardized outdoor conditions (Boerlijst et al., 2023) at the Hortus botanicus, Leiden, The Netherlands. The aquarium heaters were programmed at a minimum temperature of 20°C for optimal development, whilst allowing for natural fluctuations, so that the development was representative of field conditions during the peak of the Dutch mosquito season (Beck-Johnson et al., 2017; Boerlijst et al., 2023; De Majo et al., 2019). Namely, as increased temperature heightens metabolism, ion uptake and transport may be increased, making it imperative to work under such conditions.

All 45 mesocosms were filled with eight liters of dechlorinated tap water (kept at constant level during the experiments), a natural concentration of microbes, a high concentration of nutrients and a specific concentration of sea salt (Jozo, Rotterdam, The Netherlands). For the natural concentration of microbes, one liter of water from a local lake was filtered per liter of tap water using a 250  $\mu\text{m}$  plankton net and 53  $\mu\text{m}$  collector. The high concentration of nitrogen prevents food from being a limiting factor and thus minimalizes cannibalism (Koenraadt & Takken, 2003). This was achieved by adding 20 mg/L N in the form of dry cow manure (2.4% N, 1.5% P<sub>2</sub>O<sub>5</sub>, and 3.1% K<sub>2</sub>O) to the water. The mesocosms were randomly allocated to five increasing concentrations of commercially available sea salt – 0 g/L, 2 g/L, 4 g/L, 6 g/L, and 8 g/L Cl<sup>-</sup> – and split into two rounds of experiments due to spatial constraints, which are described below. The treatments were representative of freshwater (Oude Essink et al., 2010), the highest measured salinity in a Dutch ditch (Geest et al., 2022), the LD50 (Kengne et al., 2019), the highest measured salinity in seepage water (Geest et al., 2022), and the highest reported LD100 for *Cx. pipiens* (Kengne et al., 2019), respectively (Table 4.1). In the first round, 0 g/L, 2 g/L, and 6 g/L Cl<sup>-</sup> were used, and in the second round, 0 g/L, 4 g/L, and 8 g/L Cl<sup>-</sup> were used.

**Table 4.1** Conversion table salinity treatments

	Chloride			Total salts		
	g/L (‰)	ppm	%	g/L (‰)	ppm	%
Fresh water	0.0	0	0.0	0.0	0	0.0
Maximum ditch	2.0	2002	0.2	3.6	3604	0.4
LD50	4.0	4005	0.4	7.3	7308	0.7
Maximum seepage	6.0	6007	0.6	11.0	11013	1.1
LD100	8.0	8009	0.8	14.6	14617	1.5
Typical sea water	18.9	18921	1.9	34.5	34539	3.5

For each of the concentrations, a mixture of water, microbes, nutrients, and sea salt was prepared (Boerlijst et al., 2023; Dellar et al., 2022), and salt was added over the course of four days in equal parts to limit osmotic stress to the microbial community. The mixture was thereafter covered with fine mesh (0.1 mm) to prevent additional colonization and subsequently left to acclimatize for a period of two weeks. After the acclimation period, the water was divided over the experimental mesocosms using a 500  $\mu\text{m}$  sieve to filter out any detritus and

macroinvertebrates. After filtering, 100 second instar larvae were added, and the aquarium heaters were turned on. Allocation of the populations and saline concentrations was performed in a Latin square, leading to 5 replicates for each population-concentration combination. During the experiment, the mesocosms were once again closed off using mesh to prevent predation and colonization from the outside and to ensure that the emerged mosquitoes could not escape. Temperature, chlorophyll-a concentration, turbidity, and conductivity were measured as potential covariates using a Hach HQ40d multi and Turner designs Aquafluor. Before the second round of the experiment, the original mixtures were collected, and the concentrations were increased from 2 g/L to 4 g/L and from 6 g/L to 8 g/L. The mixtures were once again left to acclimatize and were subsequently allocated to a new Latin square.

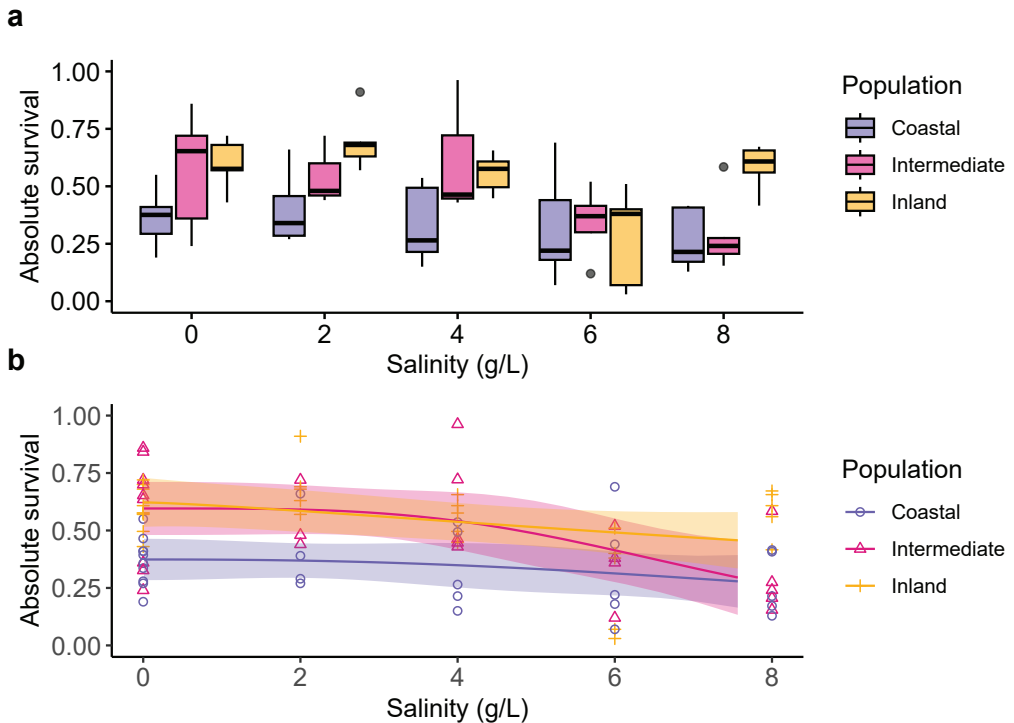
### 4.2.3 Measurements of population parameters

Larval development was measured five days a week. First, the water was stirred clockwise once with a 400 mm wide  $\varnothing$  200  $\mu$ m sieve to create a circular water flow and prevent the larvae from diving. The sieve was subsequently used to collect the larvae by fully submerging the sieve and moving it counterclockwise twice. All the collected larvae were morphologically characterized to developmental stage by using the size of the head capsule as a morphological indicator (Becker et al., 2010). The identifications were compared daily with a previously reared reference collection of *Cx. pipiens* developmental stages. The procedure was repeated up to five times until at least twenty larvae were sampled.

Pupa were collected daily, after which they were allowed to emerge in 50 ml falcon tubes. Sex was determined based on characteristics, including plumose/pilose antennae and the length of the palps (Becker et al., 2010). The proportion of total survival was determined by dividing the number of emerged adults by the original density of 100 larvae. The proportion of survival, used for visualization, were calculated by subtracting the mean of the control per population from the absolute survival rate. The time to pupation was determined after completion of the experiment. Time to pupation was defined as the interval between the start of the experiment and the first day upon which at least 50% of the subsampled larvae had turned/developed into pupae. The median time to emergence was determined by calculating the interval between the start of the experiment and capture of 50% of the emerged adults. When no more pupae and adult mosquitoes were found for two subsequent days in a mesocosm, it was assumed that there were no living mosquitoes left and the mesocosm was closed off.

#### 4.2.4 Ovipositioning behavior

The ovipositioning behavior of the coastal population was determined in a separate experiment at the Hortus botanicus Leiden, The Netherlands. Five clusters – each consisting of one black, plastic 8 L bucket for each of the five salt concentrations – were placed around the botanical gardens at a distance of at least 58 m from each other to prevent the clusters from interfering with each other. The water, microbial community and salinity levels were prepared as described in the previous section. Ovipositioning behavior was recorded by daily counts of egg rafts per mesocosm for a total of twelve days. Encountered egg rafts were removed to minimize the positive feedback caused by their presence (Bruno & Laurence, 1979).



**Figure 4.1** Proportion of normalized total survival per population across increasing salinization levels as a. boxplot with outliers as dots and b. dose-response curve with standard error. Total survival is depicted as the number of emerged adults at the end of the experiment as a fraction of the initial number of larvae.

#### 4.2.5 Statistical analyses

All data were analyzed in R version 4.2.2 (R Core Team, 2018). Variance across experimental rounds was normalized based on the observed variance across the experimental rounds per population per salinity. Log-logistic regression was used to determine the LD50 and LD100 using the drc package (Ritz et al., 2015). Linear mixed effects models were used to test for (normalized) differences in survival, development time (to pupation and emergence) and sex ratio across the different salinity levels. The salinity level, population, experimental round, average turbidity, conductivity and chlorophyll-a concentration were included as covariates. The individual mesocosms were included as random effect. The effect on ovipositioning behavior was explored similarly; a linear mixed model was applied using salinity level as main effects and day and location as random variables. All models (Supplementary Table 4.1) were optimized by Akaike information criterion using stepwise regression with backwards elimination. Dependent variables were tested for normality and assessed using quantile quantile plots and Levene's test ( $P=0.05$ ).

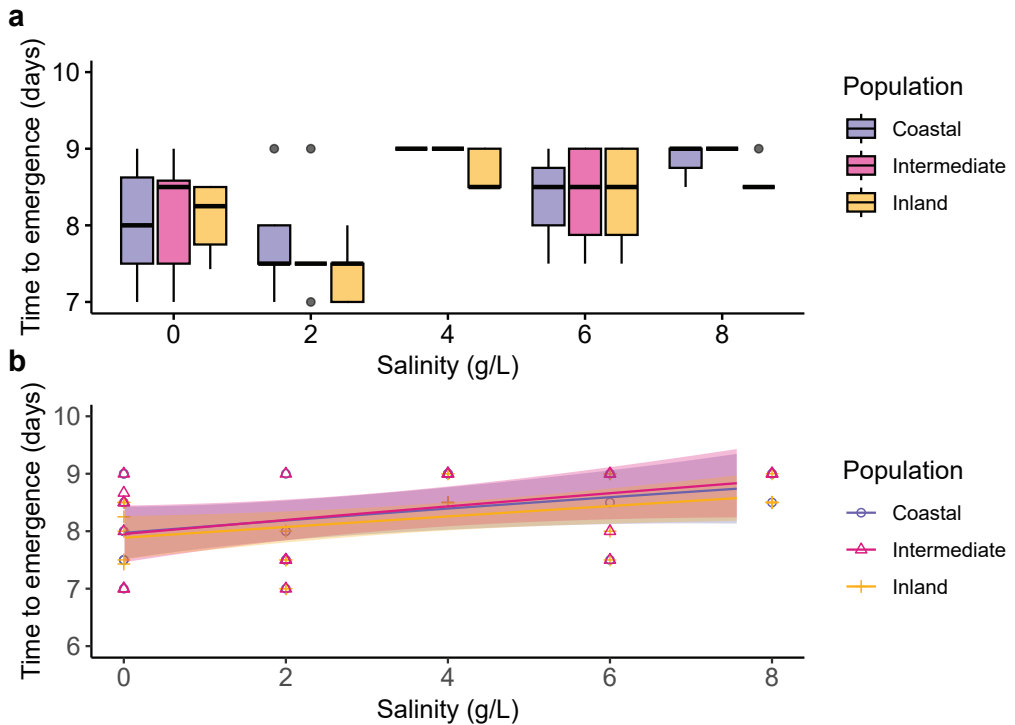
### 4.3 Results

#### 4.3.1 Effect of salinity on total proportion of survival

The total proportion of survival decreased with increasing salinity for all populations ( $F_{(4,85)}=5.60$ ,  $p<0.001$ , partial  $\eta^2=0.281$ ), with 18%, 42% and 20% ( $p<0.001$ ,  $p=0.005$ , and  $p=0.001$  for coastal, intermediate and inland respectively; Figure 4.1) from 4 g/L onward (Supplementary Table S4.2). Differences in slope were detected between the coastal and intermediate population ( $t_{(30,27)}=-2.51$ ,  $p_{\text{adj}}<0.001$ ), coastal and inland population ( $t_{(30,28)}=-3.83$ ,  $\text{adj}=0.031$ ), but not between the intermediate and inland populations ( $t_{(28,27)}=0.69$ ,  $p_{\text{adj}}>0.05$ ).

#### 4.3.2 Effect of salinity on development rates

A minor increase in the time to pupation (Supplementary Figure S4.1) and time to emergence (Figure 4.2) was detected with increasing salinity. Development to emergence was equally slowed for all populations. On average, the larvae exposed to 8 g/L took 1 day longer to emerge than those exposed to 0 g/L NaCl ( $t(4,71)=-2.849$ ,  $p<0.041$ , partial  $\eta^2=0.412$ ; Figure 4.2; Supplementary Table S4.3).



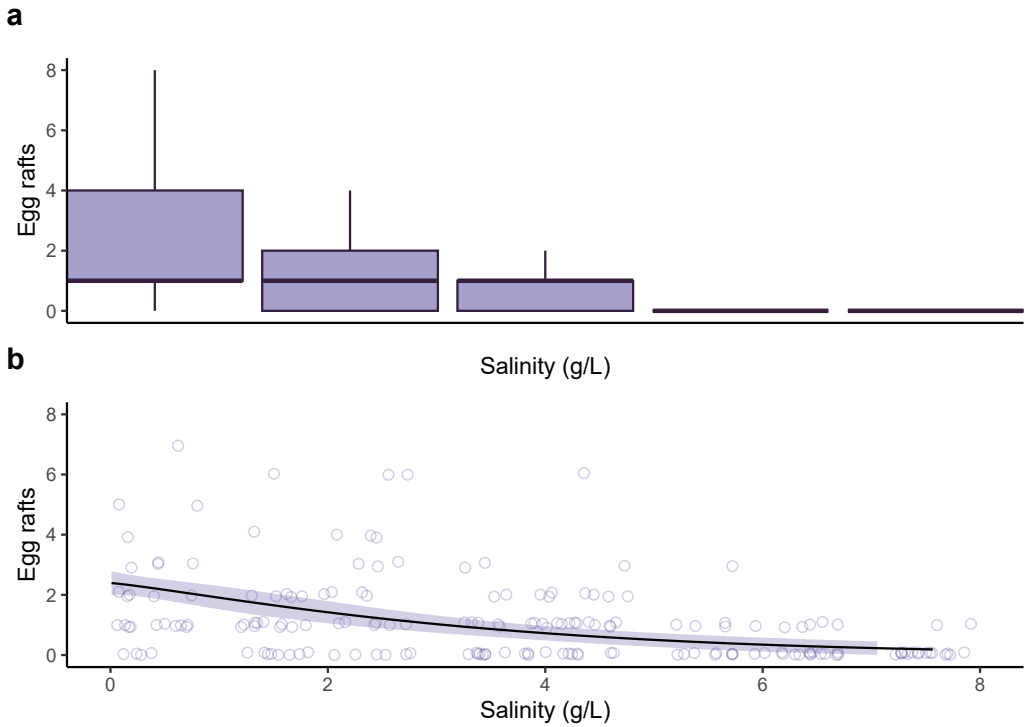
**Figure 4.2** Normalized median time to emergence in days per population across increasing salinization levels as a. boxplot with outliers as dots and b. dose-response curve with standard error.

#### 4.3.3 Effect of salinity on sex ratio

A minor difference in sex ratio was detected with increasing salinity or among any of the populations ( $F(2,62) = 3.266$ ,  $p=0.045$ , partial  $\eta^2 = 0.102$ ; Figure 4.3; Supplementary Table S4.4), between the coastal and inland populations ( $p_{\text{adj}}=0.013$ ).

#### 4.3.4 Effect of salinity on ovipositioning behavior

Oviposition decreased with increasing salt concentration ( $F(4,297) = 25.863$ ,  $p<0.001$ , partial  $\eta^2 = 0.273$ ; Figure 4.3; Table 4.2; Supplementary Table S4.5). The average oviposition rate decreased by 67% to 1.5 rafts or approximately 300 eggs (Becker et al., 2010) at 2 g/L and subsequently by 11% to 1 or approximately 200 eggs at 4 g/L. Oviposition rates at 6 g/L were almost negligible at 9%.



**Figure 4.3** Daily ovipositioning behavior across increasing salinization levels, showing the number of egg rafts for each salinization level as a. boxplot and b. dose-response curve with standard error.

**Table 4.2** Summary statistics on the ovipositioning rates for each salinity comparison

Contrast	Estimate	SE	t ratio	Adj. p value
0 g/L - 2 g/L	1.52	0.665	2.285	0.1997
0 g/L - 4 g/L	1.92	0.667	2.879	0.07
0 g/L - 6 g/L	4.69	0.665	7.058	<.0001***
0 g/L - 8 g/L	5.79	0.665	8.711	<.0001***
2 g/L - 4 g/L	0.4	0.663	0.604	0.9724
2 g/L - 6 g/L	3.17	0.661	4.802	0.0016**
2 g/L - 8 g/L	4.27	0.661	6.464	0.0001***
4 g/L - 6 g/L	2.77	0.663	4.183	0.0055**
4 g/L - 8 g/L	3.87	0.663	5.841	0.0002***
6 g/L - 8 g/L	1.1	0.661	1.663	0.4824

## 4.4 Discussion and conclusion

Contrary to our expectations, our results suggest that investigated populations of *Cx pipiens* are highly tolerant to salinization, irrespective of their proximity to the current coastline. At the highest salinity (Figure 4.1), representative of almost half the concentration of sea water, more than half of the larvae survived for all tested populations, instead of the expected 0% (Brown & Platzer, 1978; Chidester, 1916; Kengne et al., 2019). Differences in development rates among populations were observed, yet the influence of salinity was evident only at 4 g/L or higher, resulting in a minor delay (Figure 4.2). The sex ratios remained unaffected across the tested range, indicating no expected effect on potential population growth (Figure 4.3). Our data additionally suggest that, although concentrations up to the previously described LD50 (4 g/L) were favored during egg laying, *Cx. pipiens* readily lays eggs under conditions of up to 6 g/L Cl<sup>-</sup> and, incidentally, under 8 g/L Cl<sup>-</sup>. This finding is in line with observational data, as *Cx. pipiens* has recently been repeatedly observed to inhabit Dutch salt marches (pers. comm. J.G. van der Beek), which suggests a more congruent link between ovipositioning behavior and larval survival than has been described for other species (D. Roberts, 1996; D. M. Roberts & Irving-Bell, 1997; Yee et al., 2020).

Our observations are striking in contrast to the previously described LD100 of 6-7 g/L Cl<sup>-</sup> in the USA and France (Brown & Platzer, 1978; Chidester, 1916; Kengne et al., 2019). There are several methodological differences that exist between the current study and previous literature: i) the use of second-instar larvae, which might increase the potential for physiological changes in response to saline conditions (Bradley, 1987) compared to the use of older larvae; ii) the use of eutrophic conditions, which, by increasing the energy budget of the larvae, might allow for higher metabolic rates, increasing the ability to expel the ionic waste (Bradley & Phillips, 1976); and, finally, iii) gradual acclimation of the locally sourced microbial community, which might have allowed for a higher microbial abundance and thus food availability during the experiment. The latter might have allowed for increased uptake of organic compounds, which may reduce the effects of the water's osmolality (De Brito Arduino et al., 2015). While the relevance of each of these differences in setup cannot be distinguished with the current setup, the difference in total survival between our study and the earlier findings is far greater than might be explained by changes in methodology.

As our experimental setting is more representative of field conditions, the currently described responses might be more ecologically relevant than those described in previous studies under controlled conditions in the laboratory, as these generally use alternate food sources (e.g. fish feed), tap water without a natural microbial community (Kauffman et al., 2017), or laboratory-reared communities of a laboratory colony with a single subspecies. Given the ecological relevance of the setup applied, the observed pattern might be representative of populations in the Netherlands and possibly even for many other, low-lying deltas. Based on these results, we speculate that similar patterns may exist for other mosquito species that inhabit lowland delta areas, such as *Culiseta morsitans*, *Culex modestus* and perhaps even *Aedes aegypti*, which would imply that the current LD50 and LD100 should be reassessed. Taken together, the difference in the responses of our study and laboratory studies suggests that, while a wide range of mosquito species are typically associated with freshwater systems (Multini et al., 2021), they may exhibit substantial plasticity and/or (local) adaptation to increasing salinization.

The current results suggest that coastal house mosquito populations will persist and will not show salinity-induced inland dispersal or local reductions in survival. The ecological implications are that they may instead locally increase in population size, despite the presence of predators. Many freshwater predator groups, including dragonflies and damselflies (Golovatyuk & Shitikov, 2016) and mayflies and true bugs (Dunlop et al., 2008), have longer generation times and may be vulnerable to salinization within the range tested. However, this assumption remains to be tested. Species diversity in transitory systems tends to decrease between freshwater and saline water (Bleich et al., 2011; Telesh et al., 2013), while total insect abundance may remain unchanged (Silberbush et al., 2005). Consequently, species that are able to persist in such systems may experience alleviation of predation pressure, causing population sizes to increase over time and strengthening nuisance and disease risk. However, additional information is needed, as many studies on the tolerances of predator species are prone to methodological limitations similar to those of prior work on mosquitoes themselves. Nevertheless, house mosquito nuisance in coastal areas is likely to persist during the foreseeable future, and our results suggest that it is not unlikely that other mosquito species in coastal areas are similarly able to adapt to increasing salt levels even though their predators cannot.

---

## Acknowledgements

Gertjan Geerling is gratefully acknowledged for his help in the collection of egg rafts. We thank Hortus botanicus Leiden for allowing us to conduct our experiments on their premises. We thank Toos van Peuzelen for their helpful discussions and support during the conceptualization and collection of the data.

## Author contributions

SB and MS conceived the general idea for the experiments. SB set up the experiments, and AG and LA carried out the measurements. Interpretation was performed by SB together with EB, RB, PB and MS. SB carried out all statistical analyses, together with PB and MS. All the authors contributed critically to the drafts and gave final approval for publication.

## Availability of data and materials

Data supporting the conclusions of this article are included within the article and its additional files. The original datasets used and analyzed during the present study are freely and openly available within the supplementary information files.

## Ethics approval and consent to participate

Not applicable. Ethical clearance was not needed for this study.

## Consent for publication

Not applicable.

## Competing interests

The authors declare that they have no competing interests.

## Electronic appendix

### Time to pupation

Lambda = 2

Formula:  $((\text{Day}^\lambda - 1)/\lambda) \sim \text{Treatment} + (1 | \text{Cosm})$

Data: DR\_MTP

#### Analysis of Variance Table

	npar	Sum Sq	Mean Sq	F value
Treatment	4	2006.8	501.7	7.2123

REML criterion at convergence: 1608

#### Scaled residuals:

Min	1Q	Median	3Q	Max
-2.4045	-0.4825	0.2376	0.6180	2.1521

#### Random effects:

Groups	Name	Variance	Std.Dev.
Cosm	(Intercept)	0.00	0.00
Residual		72.94	8.54

Number of obs: 228, groups: Cosm, 45

#### Fixed effects:

	Estimate	Std. Error	t value
(Intercept)	28.0353	0.9263	30.265
Treatment2	-6.4149	1.4862	-4.316
Treatment4	7.4111	1.8609	3.983
Treatment6	1.4353	1.7330	0.828
Treatment8	6.6869	1.8866	3.544

#### Correlation of Fixed Effects:

	(Intr)	Trtmn2	Trtmn4	Trtmn6
Treatment2 -	0.623			
Treatment4 -	0.498	0.310		
Treatment6	-0.535	0.333	0.266	
Treatment8	-0.491	0.306	0.244	0.262

optimizer (nloptwrap) convergence code: 0 (OK)

Taking it with a grain of salt

(Intercept)	Treatment2	Treatment4	Treatment6	Treatment8	
1.479537e-80	2.393689e-05	9.253775e-05	4.084389e-01	4.802100e-04	
Contrast	estimate	SE	df	t.ratio	p.value
Treatment0 - Treatment2	6.415	1.49	48.5	4.299	0.0008
Treatment0 - Treatment4	-7.411	1.86	114.8	-3.977	0.0011
Treatment0 - Treatment6	-1.435	1.74	83.3	-0.825	0.9221
Treatment0 - Treatment8	-6.687	1.89	118.0	-3.540	0.0051
Treatment2 - Treatment4	-13.826	1.99	200.8	-6.936	<.0001
Treatment2 - Treatment6	-7.850	1.88	101.5	-4.183	0.0006
Treatment2 - Treatment8	-13.102	2.02	134.3	-6.497	<.0001
Treatment4 - Treatment6	5.976	2.18	159.6	2.737	0.0530
Treatment4 - Treatment8	0.724	2.30	183.5	0.314	0.9979
Treatment6 - Treatment8	-5.252	2.20	194.7	-2.382	0.1245

Note: contrasts are still on the ( scale

Degrees-of-freedom method: kenward-roger

P value adjustment: tukey method for comparing a family of 5 estimates

*Time to emergence*

Lambda = 2

Formula: ((Day^lambda - 1)/lambda) ~ Treatment + (1 | Cosm)

REML criterion at convergence: 1256

Analysis of Variance Table

	npar	Sum Sq	Mean Sq	F value
Treatment	4	2006.8	501.7	7.2123

Scaled residuals:

Min	1Q	Median	3Q	Max
-2.24368	-0.80490	0.09433	0.95199	1.45162

Random effects:

Groups	Name	Variance	Std.Dev.
Cosm	(Intercept)	0.00	0.00
Residual		69.56	8.34

## Chapter 4

Number of obs: 180, groups: Cosm, 44

Fixed effects:

	Estimate	Std. Error	t value
(Intercept)	30.713	1.011	30.366
Treatment2	-2.820	1.505	-1.874
Treatment4	7.587	2.379	3.189
Treatment6	1.347	1.951	0.690
Treatment8	6.631	2.317	2.861

Correlation of Fixed Effects:

	(Intr)	Trtmn2	Trtmn4	Trtmn6
Treatment2	-0.672			
Treatment4	-0.425	0.286		
Treatment6	-0.518	0.348	0.220	
Treatment8	-0.436	0.293	0.186	0.226

optimizer (nloptwrap) convergence code: 0 (OK)

(Intercept)	Treatment2	Treatment4	Treatment6	Treatment8
3.139731e-71	6.262380e-02	1.695946e-03	4.908814e-01	4.742289e-03

Contrast	estimate	SE	df	t.ratio	p.value
Treatment0 - Treatment2	2.820	1.51	37.4	1.864	0.3541
Treatment0 - Treatment4	-7.587	2.39	129.2	-3.172	0.0160
Treatment0 - Treatment6	-1.347	1.97	60.0	-0.685	0.9591
Treatment0 - Treatment8	-6.631	2.33	116.2	-2.849	0.0407
Treatment2 - Treatment4	-10.407	2.44	160.6	-4.273	0.0003
Treatment2 - Treatment6	-4.167	2.02	66.9	-2.062	0.2486
Treatment2 - Treatment8	-9.451	2.37	122.5	-3.983	0.0011
Treatment4 - Treatment6	6.240	2.74	133.5	2.277	0.1590
Treatment4 - Treatment8	0.956	3.01	160.6	0.318	0.9978
Treatment6 - Treatment8	-5.284	2.69	174.0	-1.968	0.2862

Note: contrasts are still on the ( scale

Degrees-of-freedom method: kenward-roger

P-value adjustment: tukey method for comparing a family of 5 estimates

Sex-ratio

Lambda = 0.3838384

Formula:  $((\text{SRlog\_corrected\_rel}^\lambda - 1)/\lambda) \sim \text{City} + (1 \mid \text{Cosm})$

REML criterion at convergence: 151

Analysis of Variance Table

	npar	Sum Sq	Mean Sq	F value
City	2	0.23147	0.11573	3.0896

Scaled residuals:

Min	1Q	Median	3Q	Max
-1.43023	-0.85746	0.08101	0.65570	2.71416

Random effects:

Groups	Name	Variance	Std.Dev.
Cosm	(Intercept)	0.0000	0.0000
Residual		0.6493	0.8058

Number of obs: 62, groups: Cosm, 45

Fixed effects:

	Estimate	Std. Error	t value
(Intercept)	-1.9143	0.1758	-10.887
Intermediate	0.1141	0.2487	0.459
Inland	0.4615	0.2518	1.833

Correlation of Fixed Effects:

	(Intr)	CtyUtr
Intermediate	-0.707	
Inland	-0.698	0.494

optimizer (nloptwrap) convergence code: 0 (OK)

(Intercept)	Intermediate	Inland
1.520655e-15	6.481710e-01	7.199709e-02

## Chapter 4

Total proportion of survival

Lambda = 0.5858586

Formula: ((ASR\_corrected\_rel^lambda - 1)/lambda) ~ City + Treatment + (1 | Cosm)

REML criterion at convergence: 36.4

	npar	Sum Sq	Mean Sq	F value
City	2	0.63438	0.31719	8.2936
Treatment	4	0.85740	0.21435	5.6047

Scaled residuals:

Min	1Q	Median	3Q	Max
-2.06181	-0.55392	-0.00123	0.56390	2.81515

Random effects:

Groups	Name	Variance	Std.Dev.
Cosm	(Intercept)	0.01721	0.1312
Residual		0.05761	0.2400

Number of obs: 85, groups: Cosm, 45

Fixed effects:

	Estimate	Std. Error	t value
(Intercept)	-0.66000	0.06881	-9.591
Intermediate	0.20807	0.07248	2.871
Inland	0.23742	0.06967	3.408
Treatment2	0.14136	0.09428	1.499
Treatment4	-0.05414	0.09205	-0.588
Treatment6	-0.33562	0.09216	-3.642
Treatment8	-0.22498	0.09021	-2.494

Correlation of Fixed Effects:

	(Intr)	Intermediate	Inland	Trtmn2	Trtmn4	Trtmn6
Intermediate	-0.510					
Inland	-0.485	0.481				
Treatment2	-0.467	-0.007	-0.051			
Treatment4	-0.497	-0.003	0.005	0.493		
Treatment6	-0.499	0.027	-0.022	0.364	0.371	
Treatment8	-0.501	-0.002	-0.016	0.371	0.379	0.517

Taking it with a grain of salt

(Intercept)	Intermediate	Inland	Treatment2	Treatment4	Treatment6	Treatment8
9.914e-15	5.302e-03	1.050e-03	1.379e-01	5.582e-01	4.919e-04	1.480e-02
Contrast	estimate	SE	df	t.ratio	p.value	
Coastal - Intermediate	-0.2081	0.0744	78.0	-2.798	0.0176	
Coastal - Inland	-0.2374	0.0713	69.7	-3.332	0.0039	
Intermediate - Inland	-0.0294	0.0742	77.5	-0.395	0.9175	

Results are averaged over the levels of: Treatment

Note: contrasts are still on the ( scale

Degrees-of-freedom method: kenward-roger

P value adjustment: tukey method for comparing a family of 3 estimates

Contrast	estimate	SE	df	t.ratio	p.value
Treatment0 - Treatment2	-0.1414	0.0945	63.9	-1.496	0.5691
Treatment0 - Treatment4	0.0541	0.0922	62.4	0.587	0.9765
Treatment0 - Treatment6	0.3356	0.0923	62.3	3.637	0.0049
Treatment0 - Treatment8	0.2250	0.0902	60.8	2.493	0.1056
Treatment2 - Treatment4	0.1955	0.0942	41.6	2.076	0.2494
Treatment2 - Treatment6	0.4770	0.1054	75.3	4.526	0.0002
Treatment2 - Treatment8	0.3663	0.1037	74.9	3.533	0.0062
Treatment4 - Treatment6	0.2815	0.1035	74.9	2.719	0.0605
Treatment4 - Treatment8	0.1708	0.1017	74.5	1.680	0.4521
Treatment6 - Treatment8	-0.1106	0.0897	38.5	-1.233	0.7323

Results are averaged over the levels of: City

Note: contrasts are still on the ( scale

Degrees-of-freedom method: kenward-roger

P value adjustment: tukey method for comparing a family of 5 estimates

Slope

group1	group2	n1	n2	statistic	df	p	p.adj
Coastal	Inland	30	28	-3.8344723	55.9619	0.000321	0.000963
Coastal	Intermed.	30	27	-2.5086395	49.80637	0.015	0.031
Inland.	Intermed.	28	27	0.6902263	47.41384	0.493	0.493



## Chapter 4

### Ovipositioning behavior

Lambda = -0.1818182

Formula: ((Egg\_rafts^lambda - 1)/lambda) ~ Treatment + (1 | Location) + (1 | Day) + (1 | Cosm)

Random effects: REML criterion at convergence: 1504.2

#### Analysis of Variance Table

	npar	Sum Sq	Mean Sq	F value
Treatment	4	887.19	221.8	25.863

#### Scaled residuals:

Min	1Q	Median	3Q	Max
-2.23494	-0.70171	0.00891	0.77327	2.20855

#### Random effects:

Groups	Name	Variance	Std.Dev.
Cosm	(Intercept)	0.3772	0.6142
Day	(Intercept)	0.8563	0.9254
Location	(Intercept)	0.6625	0.8139
Residual		8.5758	2.9284

Number of obs: 297, groups: Cosm, 25; Day, 12; Location, 5

#### Fixed effects:

	Estimate	Std. Error	t value
(Intercept)	-1.1741	0.6538	-1.796
Treatment2	-1.5191	0.6648	-2.285
Treatment4	-1.9195	0.6666	-2.880
Treatment6	-4.6923	0.6648	-7.059
Treatment8	-5.7911	0.6648	-8.711

#### Correlation of Fixed Effects:

	(Intr)	Trtmn2	Trtmn4	Trtmn6
Treatment2	-0.514			
Treatment4	-0.513	0.504		
Treatment6	-0.514	0.506	0.504	
Treatment8	-0.514	0.506	0.504	0.506

(Intercept)	Treatment2	Treatment4	Treatment6	Treatment8
7.357064e-02	2.303516e-02	4.280169e-03	1.260673e-11	2.397374e-16

Taking it with a grain of salt

Contrast	estimate	SE	df	t.ratio	p.value
Treatment0 - Treatment2	1.52	0.665	16.1	2.285	0.1997
Treatment0 - Treatment4	1.92	0.667	16.3	2.879	0.0700
Treatment0 - Treatment6	4.69	0.665	16.1	7.058	<.0001
Treatment0 - Treatment8	5.79	0.665	16.1	8.711	<.0001
Treatment2 - Treatment4	0.40	0.663	16.0	0.604	0.9724
Treatment2 - Treatment6	3.17	0.661	15.8	4.802	0.0016
Treatment2 - Treatment8	4.27	0.661	15.8	6.464	0.0001
Treatment4 - Treatment6	2.77	0.663	16.0	4.183	0.0055
Treatment4 - Treatment8	3.87	0.663	16.0	5.841	0.0002
Treatment6 - Treatment8	1.10	0.661	15.8	1.663	0.4824

Note: contrasts are still on the ( scale

Degrees-of-freedom method: kenward-roger

P value adjustment: tukey method for comparing a family of 5 estimates

**Table S4.1** Differences in survival rate over the salinity gradient

Contrast	Estimate	SE	Df	T.ratio	p value
Coastal - intermediate	-0.2081	0.0744	78.0	-2.798	0.0176
Coastal - inland	-0.2374	0.0713	69.7	-3.332	0.0039
Intermediate - inland	-0.0294	0.0742	77.5	-0.395	0.9175

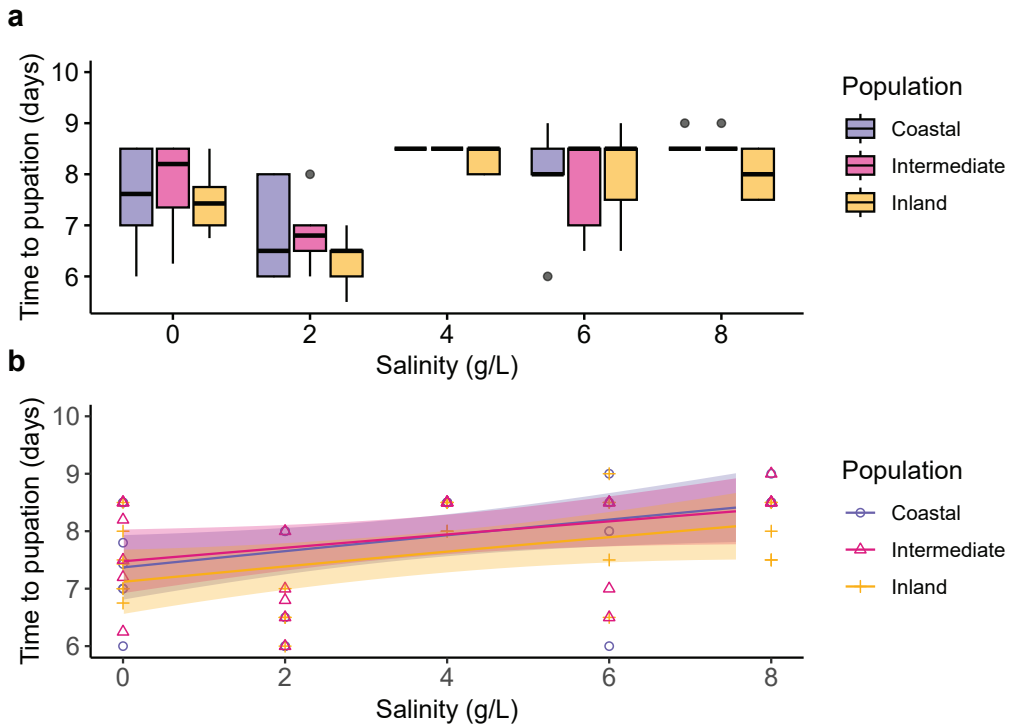
**Table S4.2** Summary statistics on the survival ratios for each salinity comparison per population

Population	Coastal		Estimate SE		Df	T.ratio	P.value
	Contrast						
	0 g/L	- 2 g/L	-0.131	0.095	62.9	-1.378	0.6437
	0 g/L	- 4 g/L	0.0714	0.0951	63.2	0.751	0.9434
	0 g/L	- 6 g/L	0.3519	0.0927	61.5	3.796	0.003
	0 g/L	- 8 g/L	0.2125	0.0927	61.7	2.293	0.1611
	2 g/L	- 4 g/L	0.2023	0.0998	41.2	2.028	0.2711
	2 g/L	- 6 g/L	0.4828	0.1061	73.3	4.551	0.0002
	2 g/L	- 8 g/L	0.3434	0.1061	73.3	3.237	0.0152
	4 g/L	- 6 g/L	0.2805	0.1064	73.3	2.635	0.0744
	4 g/L	- 8 g/L	0.1411	0.1064	73.5	1.327	0.6757
	6 g/L	- 8 g/L	-0.1394	0.0946	37.4	-1.473	0.5857

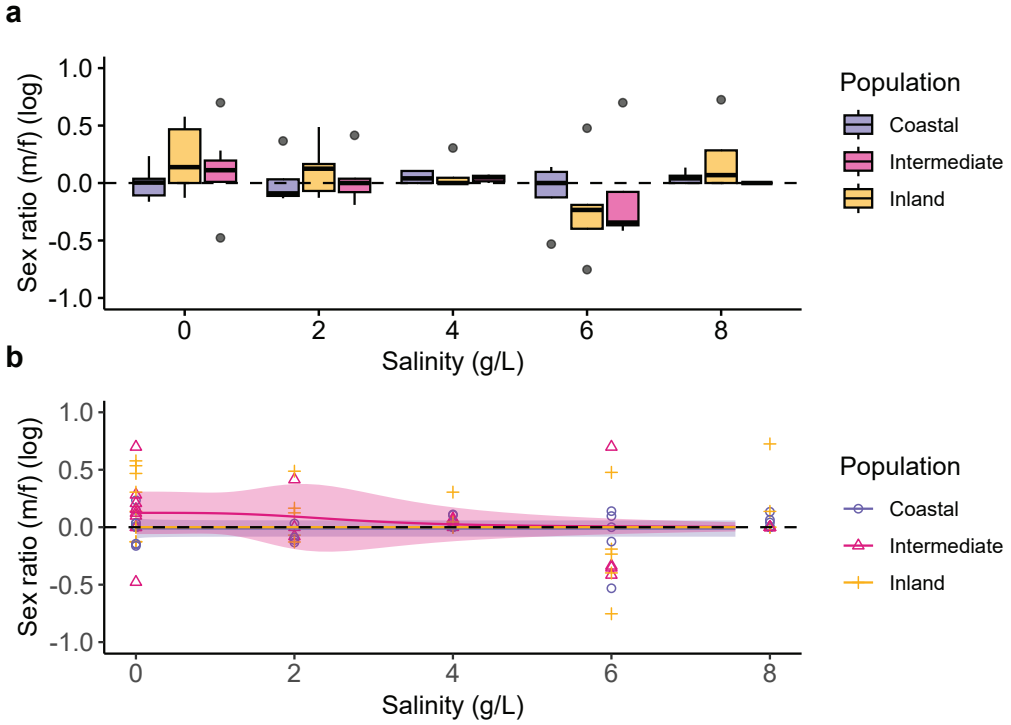
Population	Intermediate		Estimate SE		Df	T.ratio	P.value
	Contrast						
	0 g/L	- 2 g/L	-0.131	0.095	62.9	-1.378	0.6437
	0 g/L	- 4 g/L	0.0714	0.0951	63.2	0.751	0.9434
	0 g/L	- 6 g/L	0.3519	0.0927	61.5	3.796	0.003
	0 g/L	- 8 g/L	0.2125	0.0927	61.7	2.293	0.1611
	2 g/L	- 4 g/L	0.2023	0.0998	41.2	2.028	0.2711
	2 g/L	- 6 g/L	0.4828	0.1061	73.3	4.551	0.0002
	2 g/L	- 8 g/L	0.3434	0.1061	73.3	3.237	0.0152
	4 g/L	- 6 g/L	0.2805	0.1064	73.3	2.635	0.0744
	4 g/L	- 8 g/L	0.1411	0.1064	73.5	1.327	0.6757
	6 g/L	- 8 g/L	-0.1394	0.0946	37.4	-1.473	0.5857

Population	Inland		Estimate SE		Df	T.ratio	P.value
	Contrast						
	0 g/L	- 2 g/L	-0.131	0.095	62.9	-1.378	0.6437
	0 g/L	- 4 g/L	0.0714	0.0951	63.2	0.751	0.9434
	0 g/L	- 6 g/L	0.3519	0.0927	61.5	3.796	0.003
	0 g/L	- 8 g/L	0.2125	0.0927	61.7	2.293	0.1611
	2 g/L	- 4 g/L	0.2023	0.0998	41.2	2.028	0.2711
	2 g/L	- 6 g/L	0.4828	0.1061	73.3	4.551	0.0002
	2 g/L	- 8 g/L	0.3434	0.1061	73.3	3.237	0.0152
	4 g/L	- 6 g/L	0.2805	0.1064	73.3	2.635	0.0744
	4 g/L	- 8 g/L	0.1411	0.1064	73.5	1.327	0.6757
	6 g/L	- 8 g/L	-0.1394	0.0946	37.4	-1.473	0.5857





**Figure S4.1** Normalized median time to pupation in days per population across increasing salinization levels as a. boxplot with outliers as dots and b. dose-response curve with standard error.



**Figure S4.2** Normalized male to female sex ratio (transformed as natural logarithm) at the end of the experiment per population across increasing salinization levels as a. boxplot with outliers as dots and b. dose-response curve with standard error

4

**Table S4.3** Model summary statistics on the time to emergence for each salinity comparison and population.

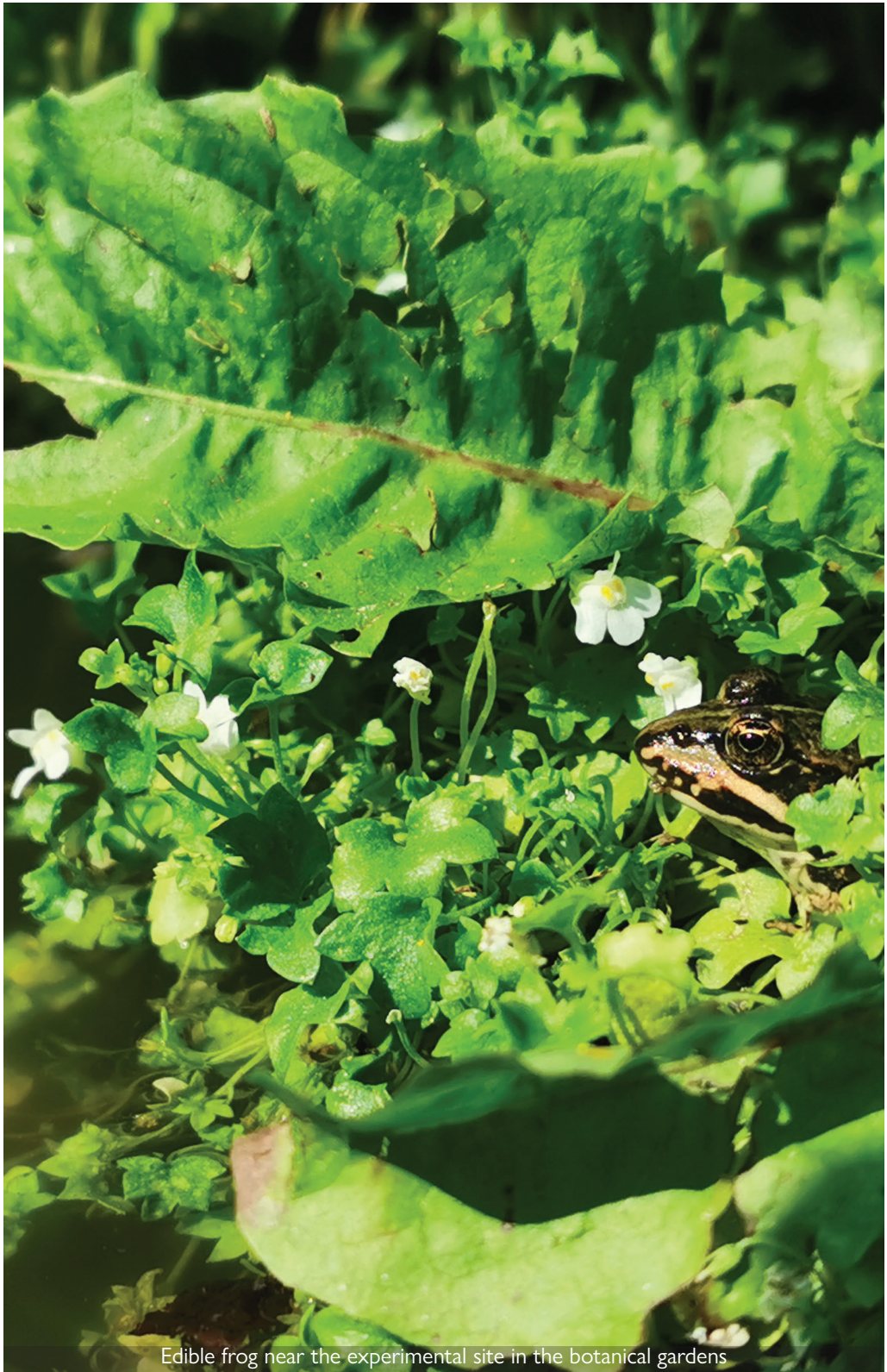
	Estimate	St.E.	t value	p value
(Intercept)	30.713	1.011	30.366	3.139731e-71
Treatment2	-2.82	1.505	-1.874	6.262380e-02
Treatment4	7.587	2.379	3.189	1.695946e-03
Treatment6	1.347	1.951	0.69	4.908814e-01
Treatment8	6.631	2.317	2.861	4.742289e-03

**Table S4.4** Model summary statistics on the male:female sex ratio for each population

	Estimate	Std. Error	t value	p value
(Intercept)	-1.9143	0.1758	-10.887	1.52E-15
Inland population	0.1141	0.2487	0.459	6.48E-01
Intermediate population	0.4615	0.2518	1.833	7.20E-02

**Table S4.5** Model summary statistics on the ovipositioning behavior for each population

	Estimate	Std. Error	t value	p value
(Intercept)	-1.1741	0.6538	-1.796	7.36E-02
Treatment2	-1.5191	0.6648	-2.285	2.30E-02
Treatment4	-1.9195	0.6666	-2.88	4.28E-03
Treatment6	-4.6923	0.6648	-7.059	1.26E-11
Treatment8	-5.7911	0.6648	-8.711	2.40E-16



Edible frog near the experimental site in the botanical gardens

## Chapter 5

### **Clashing in murky waters:** *on amphibian mosquito suppression*



Sam P. Boerlijst, Anne Ummels, Annemarieke M. Spitzen-van der Sluijs, Jeroen Spitzen, Roderick W. Bouman, Eline Boelee, Peter M. van Bodegom and Maarten Schrama



---

**Abstract**

Mosquito-borne diseases are on the rise globally due to the shifting distribution of key mosquito vector species. One Health approaches, like natural control, are gaining attention as a potential solution, especially given the link between increasing mosquito abundances and the biodiversity crisis. However, the effectiveness of different natural predators and their role in an ecological context remain poorly understood. This study compares the predator effectiveness of the common European amphibian species *Lissotriton vulgaris* and *Pelophylax kl. esculentus* to that of the common invertebrate predators *Agabus bipustulatus* and *Notonecta glauca*. We used the cosmopolitan mosquito *Culex pipiens*, known for transmitting pathogens like the West Nile virus, as a model species. We assessed predation rates, sex-specific effectiveness in amphibians, the interaction with eutrophication in *Lissotriton vulgaris* and the impact of amphibian presence on mosquito oviposition behavior. The tested amphibians proved to be effective mosquito predators, consuming between 4-8 times as many larvae per individual as compared to the invertebrates in this research. No difference in effectiveness was detected between the two amphibian species, nor between their sexes or the levels of eutrophication. Predator presence deterred oviposition behavior across the entire experimental setup, thus suggesting the ability of mosquitoes to react to a (purported) landscape of fear. The combined effect of deterring egg laying and lowering mosquito survival highlight the potential of natural predation, and particularly of amphibian species as natural larval control agents. Overall, our results highlight the importance of conserving these –globally threatened – species and facilitating them in urban and rural environments.

**Keywords:** Amphibian, biological control, control agent, *Culex pipiens*, *Lissotriton vulgaris*, *Pelophylax kl. esculentus*, urban green spaces

## 5.1 Introduction

In recent decades, distributions of several mosquito species that are key vectors of diseases have been shifting rapidly (Neiderud, 2015; Steiger et al., 2012). This has contributed to an expansion of pathogen distributions and associated increases in disease risk globally (Colón-González et al., 2021; Kraemer et al., 2015; Roche et al., 2015). Despite extensive mosquito control efforts by governments and healthcare sectors in the global south, and increasing efforts in the global north (Medlock et al., 2012), mosquito-borne diseases continue to emerge and re-emerge across the world (Ferguson, 2018).

Control of larval mosquitoes is strongly geared towards chemical interventions. In general, these measures are expensive, and their long-term effectiveness has been widely questioned (Hamdan et al., 2005; Nazni et al., 2005; Paris et al., 2011). Furthermore, direct or indirect effects on non-target organisms pose additional threats for biodiversity loss (Antwi & Reddy, 2015; Lawler, 2017; Moura & Souza-Santos, 2020; Thompson et al., 2020). As this decline in biodiversity may cause alleviation in predation pressure, mosquitoes may thrive on the long-term. Promoting ecologically healthy systems, i.e., ecosystems with an abundance of natural predators, as part of a One Health approach, has therefore gained increasing attention. With this came an increasing interest in natural control (Benelli et al., 2016), but more information is needed on which natural predators effectively suppress mosquito populations (in ephemeral water bodies), or how (neighboring) habitats could be adapted to facilitate them (Carlson et al., 2004).

The importance of natural control agents, and how their effectiveness differs in an ecological context, remains poorly understood (Shalan & Canyon, 2009). Even though, predator-prey relationships are generally well-studied, information in the context of mosquitoes is relatively scarce. This is particularly worrisome as large-scale decreases in potential predator populations were recently reported (Eisenhauer et al., 2023; Kehoe et al., 2021). Impacts on public health are therefore hard to predict, as loss of natural control agents may necessitate alternative forms of mosquito control.

To gain insight into the role of different species of mosquito predators, species specificity is likely to be a key factor. In general, predator effectiveness – i.e. kill rate or consumed prey over time – is a species-specific interaction, as anti-predator behavior differs across species and may enhance or impair kill rates

(Ohba & Ushio, 2015; Sih, 1986). Meta analyses of predation efficiency exist for groups such as dragonflies and damselflies (Priyadarshana & Slade, 2023) and mayflies (Dasrat & Maharaj, 2021), which prey on mosquitoes during their aquatic life stages (Dasrat & Maharaj, 2021; Priyadarshana & Slade, 2023). However, these analyses are limited to specific groups of (often invertebrate) predators (Benelli, 2015; Lacey & Orr, 1994; McDonald & Buchanan, 1981), while vertebrate predators have been hypothesized to be far more efficient predators (DuRant & Hopkins, 2008).

Particularly amphibians are a poorly understood mosquito predator group (Benelli, 2015), while incidentally been proven to be potentially effective natural agents, because like mosquitoes, they often depend on ephemeral water bodies (Brodman & Dorton, 2006a; DuRant & Hopkins, 2008). Aside from lowering mosquito survival, there may be other direct or indirect inter-specific interactions that adversely impact the development of mosquito larvae in shared habitats (Alto et al., 2012; Fischer et al., 2012; Meadows et al., 2017). Tadpoles, for instance, may prey on mosquito eggs, compete with larvae, predate on mosquito larvae during their later developmental stages and affect habitat choice (Weterings, 2015). Competitive effects with mosquitoes have been shown to prevent successful recolonization by mosquitoes in crustacean competitors (Kroeger et al., 2013), and as such, predator species with herbivore immature stages like frogs, may deter, limit and prevent mosquitoes from establishing. A broad scale inventory of predatorial capacity including vertebrate taxa is hitherto lacking and therefore it is not well known how predation by different predators compare across different ecological contexts.

As such, we aimed to compare the predator effectiveness of two common European amphibians — the smooth newt (Caudata: *Lissotriton vulgaris*) and the edible frog (Anura: *Pelophylax kl. esculentus*) — against two common European invertebrate mosquito predators found in ephemeral habitats: the two-spot water beetle (Coleoptera: *Agabus bipustulatus*; Culler & Lamp, 2009) and backswimmer (Hemiptera: *Notonecta glauca*; Saha et al., 2010) across a range of ecologically realistic conditions. Experiments were conducted to assess i) the predator effectiveness of selected invertebrate and vertebrate species across different levels of eutrophication, ii) whether there is a sex specificity of predator effectiveness of selected amphibian species, and iii) the effect of predator presence on mosquito oviposition behavior.

To address these aims, we conducted a series of experiments determining and comparing the predation rate on *Culex pipiens*. We focus on *Culex pipiens* s.l., a common and cosmopolitan species with a wide tolerance to temperature and eutrophication, known to occupy almost every type of water body (Becker et al., 2010a). *Culex* as a genus represents the predominant vectors of West Nile virus, Usutu, Avian malaria and Dirofilariasis amongst other pathogens, of which the *Culex pipiens* species group is the most widespread (Harbach, 2012). Wild populations of *Culex pipiens* have been confirmed to transmit Avian malaria, Batai, Sindbis and Usutu (Ibañez-Justicia et al., 2015). Due to its locally high abundance, wide distribution range and its aptitude for transmission of a variety of pathogens, it is an important vector and nuisance species. *Culex pipiens* thrives in small aquatic systems (Buxton et al., 2020), especially under hypertrophic and subsequently anoxic conditions (Boerlijst et al., 2023).

Predatory behavior on the mosquito genera *Aedes* and *Anopheles* was validated for *L. vulgaris* and *Pelophylax kl. esculentus* to determine whether our results could translate to other mosquito taxa. Adult frogs were used as development of the mouthparts allow for carnivorous diet only during the short window between Gosner stages 42 and 46 (Gosner, 1960; Johansson et al., 2010).

## 5.2 Methods

### 5.2.1 Experimental setup

The experiments consist of i) a comparison in predator effectiveness of *L. vulgaris*, *A. bipustulatus* and *N. glauca*, ii) an assessment of *L. vulgaris* predator effectiveness across different eutrophic levels, iii) a large-scale comparison of sex-specific predator effectiveness of *L. vulgaris* and *P. esculentus*, iv) an assessment of amphibian presence on mosquito oviposition, and v) a comparison of amphibian predator effectiveness on *Aedes* and *Anopheles* larvae. All experiments were performed in a full factorial setup under outdoor conditions.

#### 5.2.1.1. Pre-experimental conditions

For each experiment, we used a set of similar pre-experimental conditions. A series of mesocosms (Table 5.1) was placed in a randomized full-factorial grid. The mesocosms are representative of the artificial containers that *Cx. pipiens* is known to colonize (Koenraadt & Harrington, 2008). Each mesocosm was filled with dechlorinated tap water and a standardized community of algae and

bacteria, collected with a plankton net (250  $\mu\text{m}$  with a 53  $\mu\text{m}$  collector) from the lake next to the Living Lab field station (Leiden, The Netherlands), where all selected predator species naturally occur. The filtered algae and bacteria obtained were divided equally across all mesocosms so that one liter of water in the set-up contained as much microbes as a liter of ditch water (Dellar et al., 2022). Eutrophic levels representative of Dutch ditches (4-10mg/L N-total; Loeb and Verdonschot 2008) were created, using cow manure pellets (2,4% N; 1,5%  $\text{P}_2\text{O}_5$ ; 3,1%  $\text{K}_2\text{O}$ ) (Boerlijst et al., 2023). As such, 4 and 8 mg N-total was used for experiment 2 and 4mg N-total for all other experiments. After a day of acclimation, the contents of the mesocosms were stirred and strained through a 300 $\mu\text{m}$  sieve to remove any large particulate matter. The mesocosms were then covered with a 0.1mm mesh to prevent natural colonization by mosquitoes and predators and to prevent the emerged mosquitoes from flying out. The bacterial community was thereafter left to acclimatize for one week.

**Table 5.1** Mesocosm set-up for each of the experiments

Experiment	Mesocosm	Replicates (treatment/control)
1	16L white polypropylene	3/3
2	16L white polypropylene	8/4
3	48L black polypropylene	11 /14
4	48L black polypropylene	11/14
5	48L black polypropylene	8

Evaporated water was replenished daily using dechlorinated tap water stored at ambient temperature. To maximally mimic field conditions and to limit the amount of stress of the predators, natural shelter for salamanders in the form of a handful of Canadian waterweeds (*Elodea vulgaris*), a stone to climb out of the water, and an air stone connected to an air pump (Vt AP-10) were provided in each mesocosm. Prey densities of 50 third/fourth instar mosquito larvae were added to each mesocosm.

### 5.2.1.2 Experiment 1: comparing predator effectiveness

Kill rates of different vertebrate vs invertebrate predators were assessed in May 2020. The experiment consisted of four predator treatments, with either one individual of *L. vulgaris*, *A. bipustulatus*, *N. glauca*, or no predator (control). Each treatment combination had three replicates. The experiment took place on 6 May 2020 and had a duration of one day. The number of mosquito larvae, pupae and adults were counted 1, 2 and 3 hours after the mosquito larvae were placed in the mesocosm.

We focused on predator species that are able to survive such conditions by i.e. their ability to breath air and migrate over land, like true bugs (Fischer et al., 2012), beetles (Lundkvist et al., 2003a) and amphibians (Brodman & Dorton, 2006a). Similarly, we focused on larger predator species as they are less temperature dependent (Van Der Have & De Jong, 1996), and as food intake increases with size of the animal (DuRant & Hopkins, 2008; Jennings et al., 2002). Both *L. vulgaris* and *P. esculentus* are known to feed while in and under water (Anamaria et al., 2011; Blommers-Schlösser, 1992; Covaciu-Marcov, 2010; Sas et al., 2007, 2009; Tyler, 1958)2010; Sas et al., 2007, 2009; Tyler, 1958 and Nematocera larvae have been incidentally described as a food source (Anamaria et al., 2011; Covaciu-Marcov, 2010; Sas et al., 2007).

### 5.2.1.3 Experiment 2: Predation across eutrophication

The impact of eutrophic conditions on predator effectiveness was assessed by taking two eutrophication treatments (4mg/L N-total and 8mg/L N-total) and two predation treatments (*L. vulgaris*, control), with eight *L. vulgaris* replicates and four control replicates. The experiment took place at the beginning of May 2020 and had a duration of 5 days. The number of mosquito larvae, pupae and adults were counted 2, 4, 6, 12, 14, 16, 18, 36, 38, 40, 42, 52 and 62 hours after *L. vulgaris* had been placed in the mesocosm. We performed daily chlorophyll a and turbidity measurements using an Aquafluor 8000-010 using manufacturers protocols, as these are indicators for both visibility and resource competition due to their relation with bacterial and algal metabolism (Ansa-Asare et al., 2000; Coolidge, 2017).

### 5.2.1.4 Experiment 3: sex-specific Amphibian predator effectiveness

Amphibian predator effectiveness was assessed by imposing three predation treatments (*L. vulgaris*, *P. esculentus*, control) Due to limitations in availability, we used two male, and nine female replicates for *L. vulgaris*, seven male, and four

female replicates for *P. esculentus*, and fourteen control replicates. The experiment took place in June 2021. A terrestrial resting spot was included in each mesocosm in the form of a 180x87x41mm brick placed vertically in the water (Figure 5.1). The number of mosquito larvae, pupae and adults were counted after 1, 2, 4, 8, 24, 28, 32, 48, 56 and 72 hours, starting 40 hours after the predators were put into the mesocosms.

The experiment was repeated directly after the first round to determine whether the 40-hour food deprivation affected predatory behavior. This second round was performed in triplicate, for which a selection of the predators was used, with two male and one female replicate for *P. esculentus* and three female replicates for *L. vulgaris*. The other predators were removed from the setup and placed in experiment 5.



**Figure 5.1** Overview of experimental setup for amphibian predator effectiveness; experiment 3 (left). Contents of the mesocosms are shown on the right including the stone as resting spot and air stone for oxygen (top right), and waterweeds as natural shelter (bottom right).

### 5.2.1.5 Experiment 4: Oviposition behavior

Mosquito oviposition behavior was assessed in the experimental setup of experiment 3. After the second round of the experiment, all lids were taken off and all remaining predators were removed. The water from each mesocosm was strained through a 300 $\mu$ m sieve to remove any remaining larvae. The mesocosms were then left open for two weeks during which egg rafts were counted and removed daily. The water in each mesocosm was filtered daily using a 300 $\mu$ m sieve to prevent colonization by other (predator) species.

### 5.2.1.6 Experiment 5: Comparison with other mosquito genera

Predatory behavior on the mosquito genera *Anopheles* and *Aedes* was assessed using a glass 40x30x30cm aquarium filled with 20L low eutrophic (4mg/L N total) water. Two *L. vulgaris* or two *P. esculentus* were placed in the aquarium and left to acclimate for five minutes. Three larvae of either *Aedes sp.* or *Anopheles maculipennis* were then added, and feeding was recorded for five minutes after which the remaining mosquito larvae were removed using plastic pipettes. The predators were then collected and released at their capture location. This was repeated until all larvae had been eaten. Due to limited availability, only seven *Aedes* larvae and five *Anopheles* larvae were used in total.

### 5.2.2 Rearing of mosquito larvae

Egg rafts of *Cx. pipiens* were collected during two weeks prior to the start of an experiment at the experimental site. To this end, three 8L black polypropylene buckets were filled with three liters hypertrophic water, which has shown to be an attractive oviposition environment to female *Cx. pipiens* (100mg N-total/L; Boerlijst et al., 2023), after which they were placed under tree cover. The larvae were subsequently allowed to hatch in the buckets, where they were kept at ambient temperature until the start of the experiment. Previous studies indicated that the used conditions attract *Cx. pipiens* and *Culiseta annulata* only (Boerlijst et al., 2023; Dellar et al., 2022). The collected egg rafts were distinguished from those of *Culiseta annulata* by their difference in size (Chapman et al., 2020; Sames et al., 2005).

### 5.2.3 Sourcing predators

All predators were captured from the neighboring lake of the Living Lab field station using an aquatic net. The two invertebrate species, *A. bipustulatus* and *N. glauca*, were collected on the day of the experiment and were identified using the Freshwater Life field guide (Greenhalgh & Ovenden, 2007) whilst making

sure all individuals were of similar size. The two vertebrate species *L. vulgaris* and *P. kl. esculentus* were collected during the two days prior to the experiment. All predators were kept individually in the experimental setup until the start of the experiment to prevent cannibalistic behavior.

#### 5.2.4 Statistical analysis

All data were analyzed in R version 4.3.2 (R Core Team, 2018). Linear (mixed effects) models were used to test for differences in predator effectiveness across the experiments. Boxcox transformation was applied when applicable (Supplementary Table S5.1). All models, including random effects, were optimized by Akaike information criterion (Table 5.2). Dependent variables were tested for normality and assessed using Quantile Quantile-plots and a Levene's test ( $P=0.05$ ). Absolute mortality rates were used for statistical analysis, whereas proportion of mortality due to predation were used for visualization purposes. The proportions of mortality due to predation were calculated by subtracting the background mortality, here defined as the mean mortality in the control group per time point. As such, variance in control is not visualized, but was evaluated and thus accounted for.

**Table 5.2** Linear model after selection per experiment

Experiment	Linear model
Relative effectiveness	Mortality ~ Predator
Predation across eutrophication	Mortality ~ Eutrophication + Hours
Amphibian predator effectiveness	Mortality ~ Predator * Hours + Temperature + Error(Cosm / (Predator * Hours))
Oviposition behavior	Egg rafts ~ Predator * Day + Error(Cosm / Day)

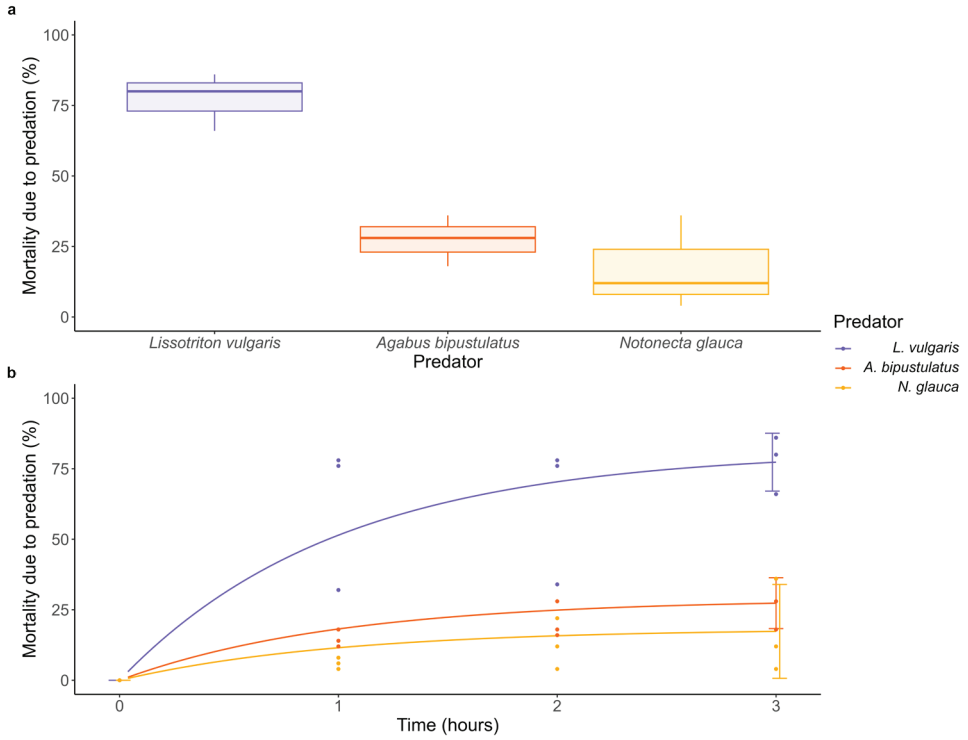
## 5.3 Results

### 5.3.1 Experiment 1: Assessing predator effectiveness

All predators successfully captured and consumed mosquito larvae (Figure 5.2; Supplementary Table S5.1). No difference in predator effectiveness was detected between *A. bipustulatus* and *N. glauca* ( $t(3,8) = -0.985$ ,  $p > 0.05$ , partial  $\eta^2 = 0.173$ , power = 1). However, differences between the vertebrate and invertebrate predators were found as *L. vulgaris* consumed on average four times as many larvae as *A. bipustulatus* ( $t(3,8) = -4.924$ ,  $p < 0.01$ , partial  $\eta^2 = 0.909$ , power = 1)

## Chapter 5

and eight times as many larvae as *N. glauca* ( $t(3,8) = -5.909$ ,  $p < 0.001$ , partial  $\eta^2 = 0.876$ , power = 1).



**Figure 5.2** Proportion of mortality due to predation (%) per predator species at the end of the experiment (a), and over time (b).

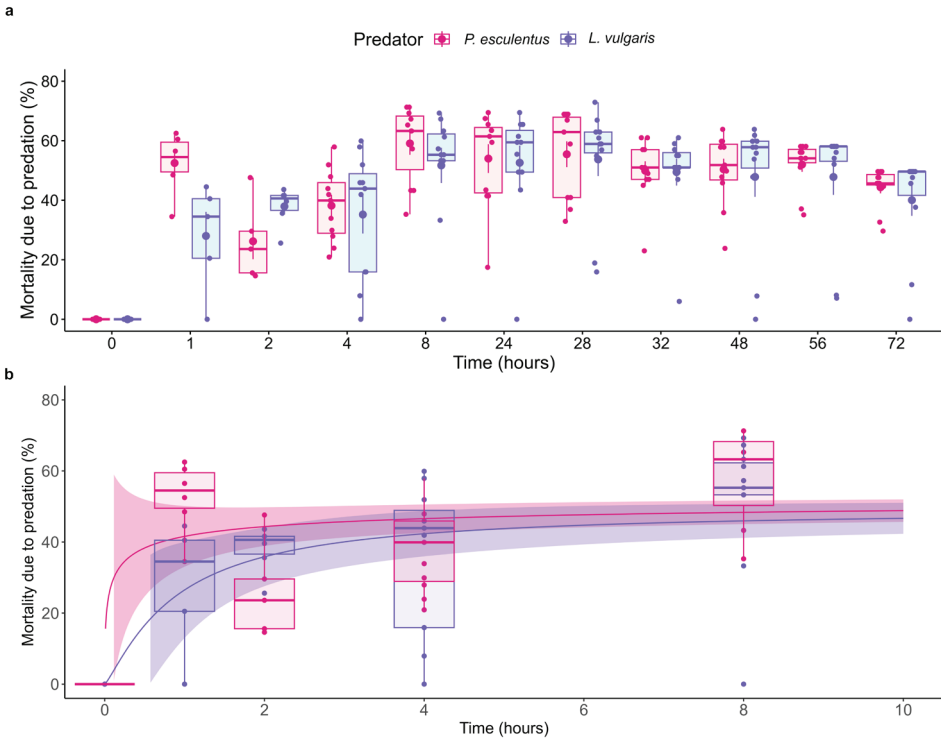
### 5.3.1.2 Experiment 2: Predation across eutrophication

*Lissotriton vulgaris* was successful in capturing mosquito larvae irrespective of eutrophication level ( $t(3,92) = -1.814$ ,  $p > 0.05$ , partial  $\eta^2 = 0.008$ , power = 0.136; Supplementary Table S5.2), and their kill rate increased over time ( $t(9,92) = 13.545$ ,  $p < 0.001$ , partial  $\eta^2 = 0.666$ , power = 1).

### 5.3.2 Experiment 3: sex-specific amphibian predator effectiveness

#### 5.3.2.1 Short-term food deprivation

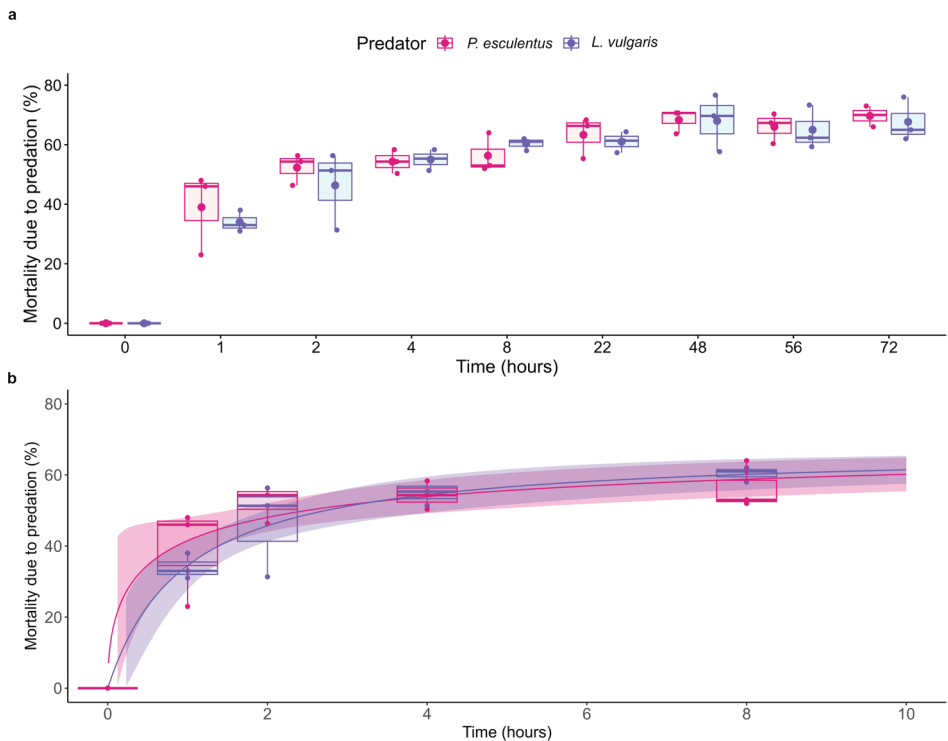
After a 40-hour food deprivation, approximately half of the (50) mosquito larvae within the experiment were eaten after 1-2 hours, which steadily progressed during subsequent hours ( $f(10,266) = 200.948$ ,  $p < 0.001$ , partial  $\eta^2 = 0.875$ , power = 1; Figure 5.3; Supplementary Table S5.3) and differed between predator treatment ( $f(20,266) = 5.253$ ,  $p < 0.001$ , partial  $\eta^2 = 0.282$ , power = 1). A minor effect of temperature was detected ( $f(1,266) = 8.279$ ,  $p < 0.01$ , partial  $\eta^2 = 0.031$ , power = 0.835). Post-hoc analysis showed higher mosquito mortality for *P. esculentus* ( $t = -4.016$ ,  $p < 0.01$ ) and *L. vulgaris* ( $t = -2.667$ ,  $p < 0.05$ ) compared to the control from 2 hours onwards. No difference between the two predator species was detected ( $t = 1.195$ ,  $p > 0.05$ ). No difference between sexes was detected (Supplementary Figure S5.1).



**Figure 5.3** Proportion of mortality due to predation (%) over time (after 40-hour food deprivation) per predator type depicted as boxplot with outliers as dots (a) and dose-response curve with standard error up until the asymptote is reached (b).

### 5.3.2.2 No short-term food deprivation

Similar kill rates were found without 40-hour food deprivation, with the majority of the prey consumed during the first two hours. Mosquito mortality increased over time ( $f(8,35) = 147.777$ ,  $p < 0.001$ , partial  $\eta^2 = 0.965$ , power = 1; Figure 5.4; Supplementary Table S5.4) per predator treatment ( $f(16,35) = 8.977$ ,  $p < 0.001$ , partial  $\eta^2 = 0.763$ , power = 1). No effect of temperature was detected ( $f(13,35) = 0.647$ ,  $p > 0.05$ , partial  $\eta^2 = 0.744$ , power = 1). Post-hoc analysis showed higher mosquito mortality for *P. esculentus* ( $t = -15.251$ ,  $p < 0.001$ ) and *L. vulgaris* ( $t = -15.163$ ,  $p < 0.001$ ) compared to the control from 1 hour onwards. No difference between the two predator species was detected ( $t = 0.406$ ,  $p > 0.05$ ). No difference between sexes was detected (Supplementary Figure S5.2).



**Figure 5.4** Proportion of mortality due to predation (%) over time per predator type without food deprivation, depicted as boxplot with outliers as dots (a) and dose-response curve with standard error up until the asymptote is reached (b).

### 5.3.3 Experiment 4: Oviposition behavior

During the two-week period, a total of 32 mosquito egg-rafts were laid, of which 27 in the control treatment (Supplementary figure S5.3; Supplementary Table S5.5). All rafts were deposited in the mesocosms located at the border of the experimental setup. Differences were detected across the predator treatments ( $X^2 = 24.86$ ,  $df = 6$ ,  $p < 0.001$ , Kramers-v = 0.19, power = 0.82). Post-hoc analysis revealed differences between the control and *L. vulgaris* ( $X^2 = 8.63$ ,  $df = 3$ ,  $p < 0.05$ ) and between the control and *P. esculentus* ( $X^2 = 18.95$ ,  $df = 3$ ,  $p < 0.001$ ).

### 5.3.4 Comparison other genera

The experiment to confirm whether other representative species from other mosquito genera were also consumed by the same predators was successful and confirmed that all 7 *Aedes* and 5 *Anopheles* larvae were eaten (Supplemental video).

## Discussion

The aim of this study was to assess the potential of amphibians to control mosquitoes, as part of a One Health approach, by determining the predator effectiveness of a range of relevant mosquito predators in temperate regions. Here, we report effects on different mosquito life stages, both during larval development and oviposition. Both amphibians (*L. vulgaris* and *P. esculentus*) exhibited similar and notably high larval consumption of *Cx. pipiens*, regardless of preceding food deprivation. *Lissotriton vulgaris* consumed four times more than *A. bipustulatus* and eight times more than *N. glauca*. Additionally, breeding sites with prior amphibian presence deterred egg-laying, also for neighboring breeding sites. These effects appear more significant and ecologically diverse than previously reported, adding to the evidence that ephemeral and permanent water bodies with an abundance of natural predators might effectively reduce mosquito populations without the need for ecologically harmful larvicides (Dale & Knight, 2012).

To date, most interventions to suppress mosquito populations involve the use of chemicals like biocides. However, these chemical methods are short-term solutions, leading to resistance (Hamdan et al., 2005; Li et al., 2002) and creating a pesticide treadmill undermining ecosystem health. As competing species are often impacted similarly, chemical control may result in rapid recolonization (Meyabeme Elono et al., 2018) and overcompensation (Juliano, 2007; Neale & Juliano, 2019) by mosquitoes and ecological imbalances (Allgeier et al., 2019; Brühl et al., 2020; Meyabeme Elono et al., 2018), posing risks, especially to conservation areas. This combined with the limited information on food-web effects (Brühl et al., 2020), and the subsequent unknown fate of the substances, makes its use in conservation areas risky. In contrast, biological control, using naturally occurring predators, presents a less problematic approach. By actively releasing or facilitating predators, it may offer a more sustainable and preventive strategy. This method deters egg-laying (Rubbo et al., 2011; Sougué et al., 2021) and limits immature survival whilst lowering growth rates, fecundity and delaying reproduction (Fischer et al., 2012; Lundkvist et al., 2003b; Schrama et al., 2018). Additionally, stressful conditions – including predator presence – promote a more heterogeneous mix of developmental stages, as a result of different growth strategies among the mosquito larvae (Fischer et al., 2012; Knight et al., 2004), which could enable cannibalistic behavior (El Hussein et al., 2018; Koenraadt & Takken, 2003). Indeed, results from our study highlight the importance of seriously

considering such measures, not only because they are likely cost-effective, but also because they may be far more sustainable than chemical alternatives.

An important remaining question is how these effects translate into more ecologically complex settings. Natural ephemeral ecosystems may be more biologically and physicochemically complex than the mesocosm setup used, which might lower real world impacts. For instance, the current experiments did not consider alternative prey, such as chironomids, which are commonly found alongside mosquito larvae (Dinithi & Hemantha, 2020; Leisnham et al., 2007; Talaga et al., 2020). Therefore, this study does not account for effects of prey preference. However, both currently assessed amphibian species hunt opportunistically (Kovács et al., 2014; Roşca et al., 2013). As mosquito larvae spend most time at the top of the water column (Becker et al., 2010b), consistently dive as anti-predator behavior (Awasthi et al., 2012), and often occur at high densities, they are considered easy prey. It can therefore be assumed that they would provide a prominent food source if available, even in complex communities, which is confirmed by their relative abundance in the stomach contents of both amphibian species (Brodman & Dorton, 2006b; Tyler, 1958). Moreover, *Cx. pipiens* often selects for breeding habitats with minimal competition and predation (Alcalay et al., 2019; Dhileepan, 1997), which further reduces potential effects of prey preference on predator behavior.

5 Similarly, the current study evaluated predator effectiveness at the individual level, without considering the effect of relative predator densities. Invertebrate predators may be present in much higher densities than amphibians. Consequently, although *L. vulgaris* and *P. esculentus* individuals consume more larvae, this effect may be less pronounced at the community level. Especially when re-evaluating predator effectiveness across average predator biomass, i.e., larvae consumed per gram (Supplementary Table S5.6), invertebrate predators seem much more effective in the short term. However, amphibians, which can readily move between water bodies and have stomachs capable of digesting large amounts of prey simultaneously (Bissattini et al., 2021; Brodman & Dorton, 2006b; Tyler, 1958), may still prove to be important predators in influencing mosquito populations over longer periods.

Our results suggest that tested amphibians are highly effective mosquito predators, irrespective of species, without discernible differences in kill rates between sexes or among similarly sized individuals of amphibians or invertebrate predators.

When applying these findings to other mosquito groups, it is essential to consider that mosquito larvae exhibit species-specific feeding behaviors that influence their position in the water column (Dadd, 1975; Merritt et al., 1992). Understanding these behaviors is crucial for assessing predator effectiveness, particularly in scenarios of static predatory behavior, necessitating comprehensive testing across diverse mosquito groups and predator species. However, it is noteworthy that a predominant anti-predator response among most mosquito larvae is diving (Awasthi et al., 2012; Sih, 1986). Notably, we found that *L. vulgaris* effectively preys on larvae of *Culex*, *Aedes*, and *Anopheles*, primarily in proximity to the container bottom, to which the larvae flee upon disturbance. *Pelophylax esculentus* was found to sit and wait floating at the water surface, we hypothesize until the larvae re-emerge after diving, consistent with previous literature (Anamaria et al., 2011; Kovács et al., 2014). As such, it is probable that our findings also translate to similar predation rates for other mosquito species.

When considering the effectiveness of predation under different abiotic conditions, it is important to recognize their interconnected nature (Krol et al., 2019). Typically, murky and nutrient-rich waters have a positive impact on larval mosquito feeding behavior (Dadd, 1975; Merritt et al., 1992), thus benefitting *Cx. pipiens*' survival (Boerlijst et al., 2023). Hence, it was expected that eutrophication would affect the capacity of predators to kill mosquito larvae (Schmutzer et al., 2008), which could operate either through lowered oxygen acquisition (Coffin et al., 2018), lowered hunting efficiency due to increased anti-predator behavior (Tuno et al., 2004), or reduced vision-based hunting (Abrahams & Kattenfeld, 1997). Surprisingly, eutrophication levels did not affect predation levels, with *L. vulgaris* successfully capturing mosquito larvae regardless, suggesting unaffected predation behavior, possibly mediated due to alternative olfactory or tactile cues (Ranta et al., 1990).

The observed effects of predators on ovipositioning may ultimately be even more important than the direct effects of larval killing, suggesting that mosquito predators are successful in establishing a mosquito landscape-of-fear. Ovipositing rates were relatively low, as adult female mosquitoes mostly refused to deposit eggs anywhere near our experimental setup. This effect was far stronger than the deterrence by abiotic factors such as salt or nutrient availability (Boerlijst et al., 2023, 2024), or relative to some invertebrate predators (Eitam & Blaustein, 2004; Why et al., 2016), indicating that these predators remain in control, even in between meals and during temporary absence.

Overall, our results suggest that amphibian predators may have important long term negative effects both on mosquito larval and egg stages. However, relative abundances of predator species play a crucial role for their effectiveness, meaning that despite the amphibians' higher effectiveness, their overall impact could be mitigated by their lower densities when compared to invertebrates. Still, given their substantial impact on ovipositioning rates, and their ability to readily move over land to colonize new ephemeral habitats, amphibians are likely relevant actors in controlling mosquito larval populations for relatively small urban habitats. As such, facilitating endemic amphibians, and endemic mosquito predators at large, in anthropogenic landscapes may prove to be a valuable and effective component of One Health approaches to mosquito control.

### **Ethical consideration**

All experiments were performed under supervision of the RAVON foundation. The Defense Safety Inspectorate deemed the experiments to be exempt of the animal experiment legislation as the discomfort inflicted was negligible since i) the displacement was within 6 meters for less than 10 days, ii) there was no (medical) intervention, iii) there was no long-term food deprivation, and iv) they were released into their original habitat.

### **Acknowledgements**

We thank Hortus botanicus Leiden for allowing us to conduct our experiments on their premises. Martha Dellar and Gertjan Geerling are gratefully acknowledged for their help during internal review.

### **Author contributions**

AS, JS and MS conceived the general idea for the experiments. SB set up the experiments, and SB and AU carried out the measurements. SB performed interpretation together with AS, JS, EB, PB, RB, and MS. SB carried out all statistical analyses, together with PB and MS. All the authors contributed critically to the drafts and gave final approval for publication.

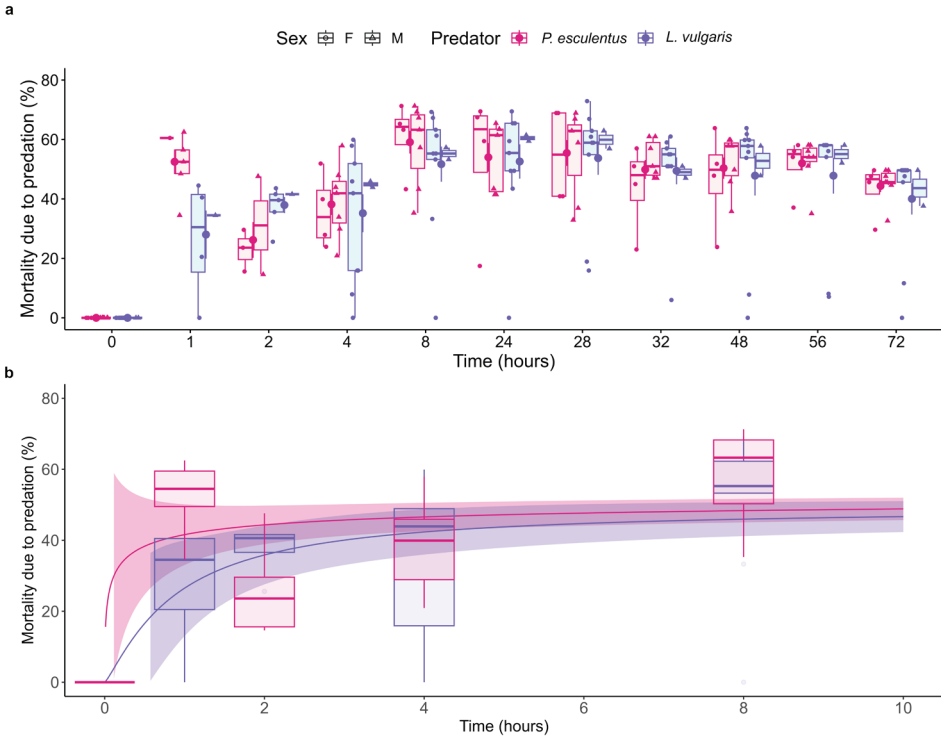
### **Conflict of interest**

The authors report no conflict of interest.

**Availability of data and materials**

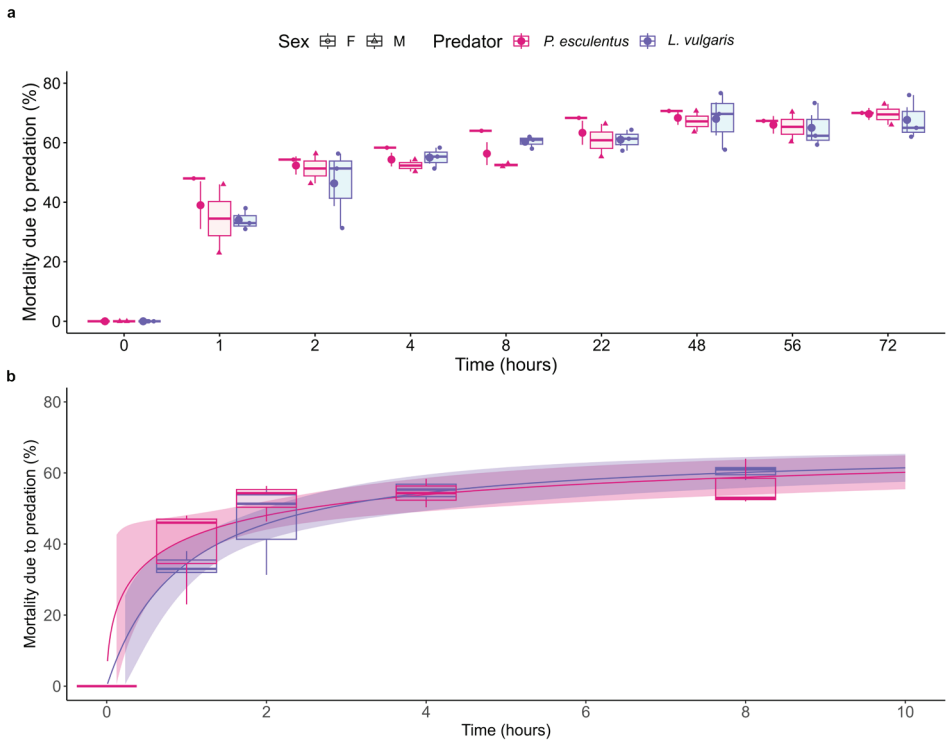
The original datasets used and analyzed during the present study are freely and openly available within the Zenodo repository [10.5281/zenodo.11128264](https://doi.org/10.5281/zenodo.11128264).

# Electronic appendix

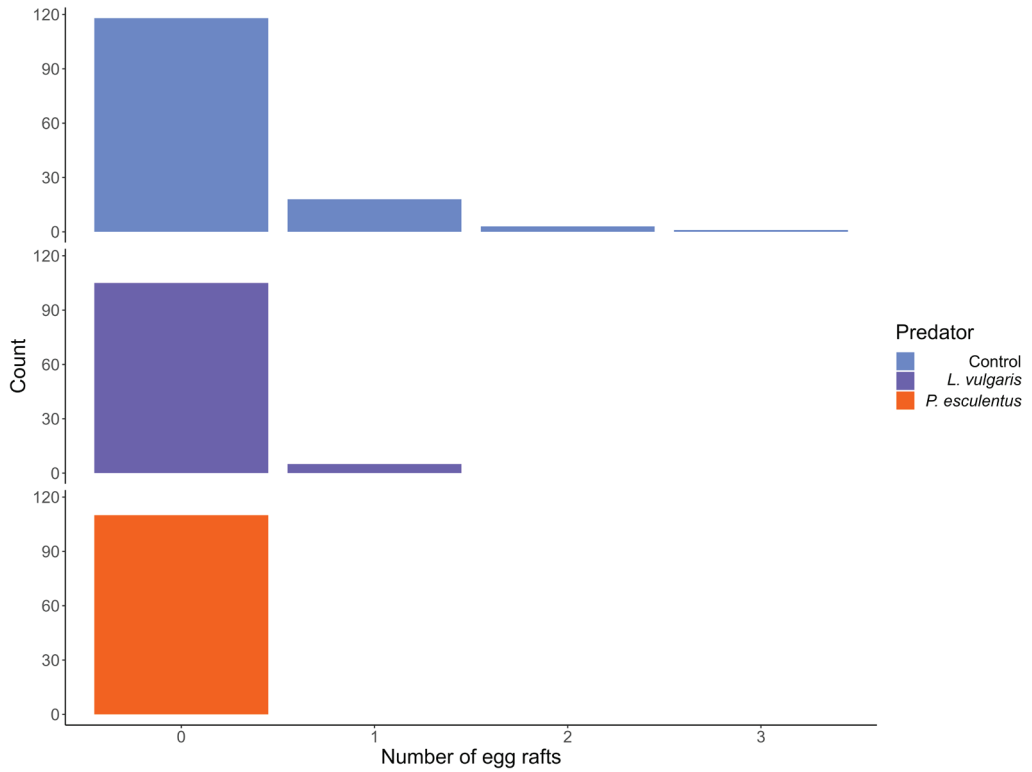


**Figure S5.1** Proportion of mortality due to predation (%) over time (after 40h fast) per predator type depicted as (a) boxplot per sex with outliers as dots and (b) dose-response curve with standard error up until the asymptote is reached. Predator sex is indicated by a circle for female, triangle for male.

5



**Figure S5.2** Proportion of mortality due to predation (%) over time per predator type without fast depicted as (a) boxplot per sex with outliers as dots and (b) dose-response curve with standard error up until the asymptote is reached. Predator sex is indicated by a circle for female, triangle for male.



**Figure S5.3** Oviposition behavior depicted as the number of egg-rafts counted per day per predator treatment over the two weeks.

5

**Table S5.1** Anova table experiment 1

	Estimate	Std. Error	t value	Pr(> t )	Signif
(Intercept)	77.33	7.18	10.770	3.79e-05	***
PredatorAga- bus bipustu- latus	-50.00	10.15	-4.924	0.00265	**
PredatorNot- onecta glauca	-60.00	10.15	-5.909	0.00105	**

Signif. codes: 0 '\*\*\*' 0.001 '\*\*' 0.01 '\*' 0.05 '.' 0.1 ' ' 1

**Table S5.2** Anova table experiment 2

	Estimate	Std. Error	t value	Pr(> t )	Signif
(Intercept)	-4.27542	13.15893	-0.325	0.7488	
Control + extra eutrophic	-1.62077	2.07676	-0.780	0.4448	
Smooth newt + eutrophic	-26.25201	1.72704	-15.201	4.36e-12	***
Smooth newt + extra eutrophic	-28.55619	1.73145	-16.493	1.03e-12	***
Eutrophication	0.11022	0.04109	2.682	0.0147	*

Signif. codes: 0 '\*\*\*' 0.001 '\*\*' 0.01 '\*' 0.05 '.' 0.1 ' ' 1

**Table S5.3** Anova table experiment 3 round 1

	Df	Sum Sq	Mean Sq	F value	Pr(>F)	Signif
Time	10	47.07	4.707	200.948	< 2e-16	***
Temperature	1	0.19	0.194	8.279	0.00434	**
Predator:Time	20	2.46	0.123	5.253	4.15e-11	***
Residuals	266	6.23	0.023			

Signif. codes: 0 '\*\*\*' 0.001 '\*\*' 0.01 '\*' 0.05 '.' 0.1 ' ' 1

**Table S5.4** Anova table experiment 3 round 2

	Df	Sum Sq	Mean Sq	F value	Pr(>F)	Signif
Time	8	10.702	1.3377	147.777	< 2e-16	***
Temperature	1	0.006	0.0059	0.647	0.425	
Predator:- Time	16	1.300	0.0813	8.977	1.8e-09	***
Residuals	47	0.425	0.0091			

Signif. codes: 0 '\*\*\*' 0.001 '\*\*' 0.01 '\*' 0.05 '.' 0.1 ' ' 1

**Table S5.5** Ovipositioning counts depicted as egg-rafts per day per predator treatment.

Rafts	Predator		
	control	frog	newt
0	118	110	105
1	18	0	5
2	3	0	0
3	1	0	0

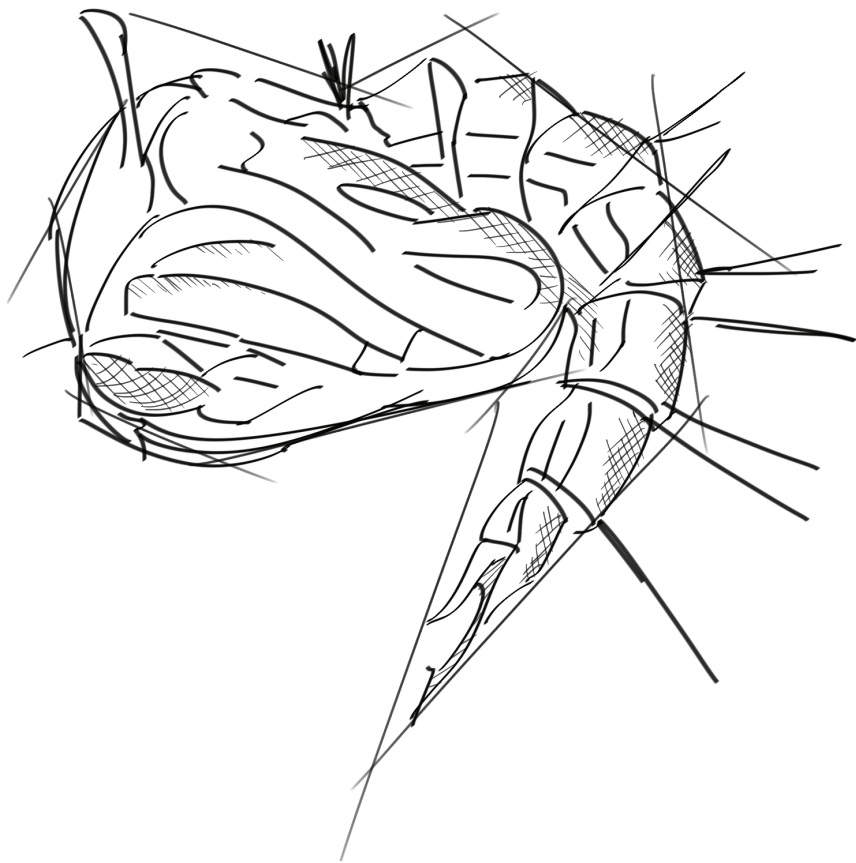
**Table S5.6** Calculations average weight per predator species and corresponding maximum kill rates per gram of predator

Species	Length (mm)	Weight (mg)	kill rate/ gram	Reference length	Reference weight	Formula
A. bipus- tulatus	6.5-7.5	1.90-2.71	2215	(Ohba & Takagi, 2010)	(Smock, 1980)	$0.019 * L^{2.46}$
N. glauca	15-16	14.86-17.42	747	(Reynal- di et al., 2011)	(Smock, 1980)	$0.019 * L^{2.47}$
L. vul- garis	66.1- 81.8	7070.97- 13611.03	3	(Bozkurt et al., 2016)	(Santini et al., 2018)	$10^{-4.375} * L^{3.215}$
P. escu- lentus	35.3- 48.6	22812.96- 64797.45	1	(Socha & Ogielska, 2010)	(Santini et al., 2018)	$10^{-4.744} * L^{3.073}$

---

**References accompanying Table S5.6**

- Bozkurt, E., Tural, M., Ulutaş, G., Üzümlü, N., & Olgun, K. (2016). Two New Paedomorphic Population Records of the Smooth Newt, *Lissotriton vulgaris schmidtleri* (Raxworthy, 1988) (Urodela, Salamandridae), from Western Turkey. *Russian Journal of Herpetology*, 23(2), Article 2. <https://doi.org/10.30906/1026-2296-2016-23-2-158-162>
- Ohba, S.-Y., & Takagi, M. (2010). Predatory Ability of Adult Diving Beetles on the Japanese Encephalitis Vector *Culex tritaeniorhynchus*. *Journal of the American Mosquito Control Association*, 26(1), 32–36. <https://doi.org/10.2987/09-5946.1>
- Reynaldi, S., Meiser, M., & Liess, M. (2011). Effects of the pyrethroid fenvalerate on the alarm response and on the vulnerability of the mosquito larva *Culex pipiens molestus* to the predator *Notonecta glauca*. *Aquatic Toxicology*, 104(1), 56–60. <https://doi.org/10.1016/j.aquatox.2011.03.017>
- Santini, L., Benítez-López, A., Ficetola, G. F., & Huijbregts, M. A. J. (2018). Length–mass allometries in amphibians. *Integrative Zoology*, 13(1), 36–45. <https://doi.org/10.1111/1749-4877.12268>
- Smock, L. A. (1980). Relationships between body size and biomass of aquatic insects. *Freshwater Biology*, 10(4), 375–383. <https://doi.org/10.1111/j.1365-2427.1980.tb01211.x>
- Socha, M., & Ogielska, M. (2010). Age structure, size and growth rate of water frogs from central European natural *Pelophylax ridibundus*-*Pelophylax esculentus* mixed populations estimated by skeletochronology. *Amphibia-Reptilia*, 31(2), 239–250. <https://doi.org/10.1163/156853810791069119>



Graphical illustration of a house mosquito pupa.

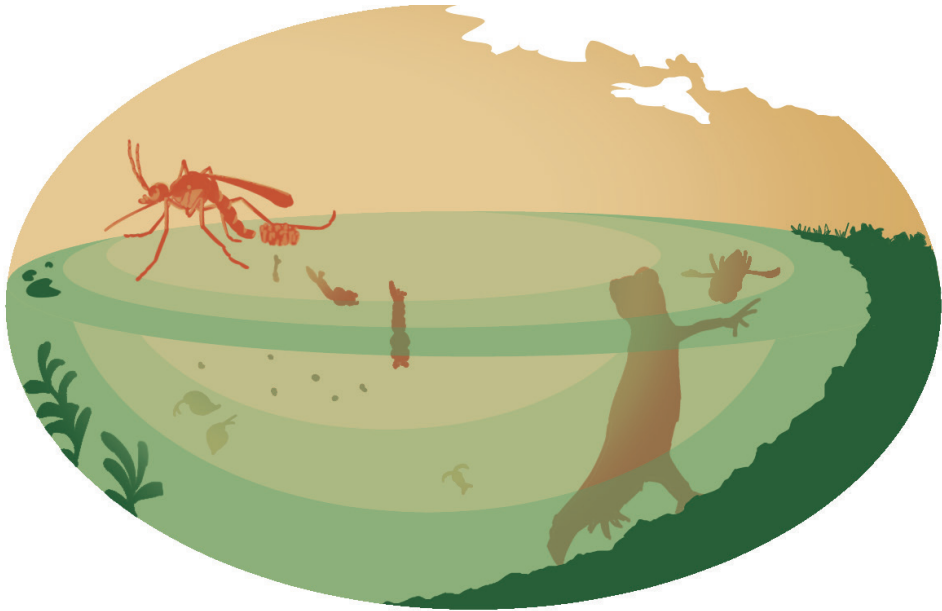
## Chapter 6

### Discussion

## 6.1 Introduction

The necessity of applying a One Health approach in emerging infectious disease challenges is increasingly acknowledged (Breitschwerdt, 2014; Destoumieux-Garzón et al., 2018; Ellwanger et al., 2022; Little, 2013). While One Health inherently implies interconnectedness of animal, human and environment health, many studies regarding the ecological side of One Health have largely resorted to simplified lab settings (De Brito Arduino et al., 2015; Ohba & Takagi, 2010; Saleeza et al., 2014) and/or focused on isolated effects of anthropogenic stressors (Kiarie-Makara et al., 2015; Sih, 1986). Such experiments fail to acknowledge that anthropogenic stressors, an omnipresent feature of most ecological systems these days, interact with the integrity of these ecological systems instead of acting purely as an external force, thus lacking ecological realism. Only recently there has been a shift towards less controlled environments allowing higher degree of ecological realism, such as field labs (Cano-Rocabayera et al., 2020; Silberbush et al., 2005). These experimental settings thereby allow for the inclusion of stressor interactions (Abrahams & Kattenfeld, 1997; Alcalay et al., 2018; Krol et al., 2019; Muturi et al., 2010), and environmentally realistic application of stressors (Beck-Johnson et al., 2017; Hall & Warner, 2020; Vajedsamiei et al., 2021).

The realization that ecological realism is key when aiming for a One Health approach to VBD represents the basis upon which this thesis is built. This work which aims to identify the main anthropogenic drivers, their stressors and relevant interactions on *Culex pipiens* (*Cx. pipiens*) population dynamics, and how these feed through in a One Health approach to *Culex*-transmitted pathogens. To make this ambitious goal attainable, and enable a structured evaluation of stressors, I classified all stressors into a nested hierarchy of three levels of increasing spatial scale (section 6.3). In the previous chapters I discussed my findings on the importance of interactive effects between stressors, which are the norm rather than the exception (**Chapter 2**), that realistic application of stressors massively affects stressor impacts (**Chapters 2 and 3**), that the ecological context of the populations evaluated – such as prior (gradual) natural exposure to the stressors – affects stressor impact (**Chapter 4**) and that bottom-up and top-down stressors indirectly impact mosquito populations via habitat selection (**Chapters 2, 3, 4 and 5**). Based on these findings, this concluding chapter will evaluate how systemic (bottom-up), external (top-down) and other stressors act and interact across ecological scales (Figure 6.1). This informs us how these should be applied in studies on experimental vector ecology, to make them more ecologically realistic. Furthermore, these insights offer a novel perspective on how higher understanding of ecological realism of *Cx. pipiens* contributes to (epidemiological) preparedness, via the processes of surveillance, risk-mapping and modelling and landscape design. Overall, this is an important step in the acknowledgement of the importance of ecological processes in the One Health approach.



**Figure 6.1** Overview of scales within which the drivers and pressures act on mosquito populations visualized as three concentric layers of increasing opacity. Bottom-up stressors, like eutrophication and salinization affect water quality and together with microclimate act on the microhabitat level, the innermost layer representing the direct surroundings of the larvae. External stressors, like competition and predation, impact community composition on the mesohabitat level, the intermediate layer. Finally, landscape characteristics, such as soil type and vegetation together with macroclimate act on the macrohabitat level, the outermost layer, representing the entire water body.

## 6.2 Applying ecological realism to One Health

One Health, as an interdisciplinary approach, recognizes the interconnectedness between human, animal and environmental health. It thereby (albeit hitherto largely theoretically) acknowledges that changes in ecosystems may impact all domains and that holistic, collaborative efforts that touch on these changes may benefit everyone involved (Cunningham et al., 2017; Danasekaran, 2024; K. M. Smith et al., 2019). By considering ecological processes, One Health approaches hold the potential to develop more effective strategies for health issues, but to date an actual, practical implication of this potential is largely lacking. Breaking this deadlock necessitates accurate knowledge on how, often complex, ecological processes interact and impact us. Ecological complexity – the interconnectedness of living systems across multiple scales, processes and interactions – originates from the field of multitrophic interactions, and stem from the simple observation that organisms interact many other organisms in their environment (Anand et al., 2010; Harvey et al., 2015). Disease transmission similarly depends on complex interactions between organisms, and is influenced by various other abiotic and

biotic factors (Su et al., 2022), across multiple spatial scales (Laporta & Sallum, 2014). More ecological realism, via the inclusion of higher levels of ecological complexity, should therefore be considered for infectious disease studies, as current approaches may be overly reductionist (de Garine-Wichatitsky et al., 2022; Maurer, 1999; Su et al., 2022).

### 6.3 The scales of ecological realism

Environmental complexity can be explored spatially, by dividing it into three (hierarchical) scales of spatial structure: microhabitat, habitat and (macro)habitat: the landscape. These scales distinctly affect habitat selection, adding to their relevance (Alcalay et al., 2019; Nikookar et al., 2015). The different scales separate the ecological interactions into bottom-up, top-down and macro-environmental pressures, respectively (Figure 6.1). Below I elaborate on how the ecological complexity that was included in this thesis plays out, and shapes ecological dynamics, at all three scales. Additionally, I discuss some of the immediate implications of my findings at each of these three scales.

#### 6.3.1 microhabitat

Small, localized physical and chemical conditions of the immediate surroundings of a given organism are defined here as the microhabitat. This scale is comprised of effects from, and spatial distribution of, compounds acting on water quality. For mosquitoes, the main relevant pressures at this scale are eutrophication, salinization and micro-climate that shape the larval microhabitat, all of which are further elaborated below. Larvicidal compounds such as heavy metals (El-Sheikh et al., 2010), plant metabolites (Al-Doghairi et al., 2004; David et al., 2000, 2001) and insecticides (Hamaidia & Soltani, 2016; Li et al., 2002) act on this scale as well, but are not further evaluated as this thesis focuses on naturally occurring ecological pressures.

Eutrophication results in nutrient accumulation in aquatic system, and is an important regulator of the potential primary biomass production, primarily achieved by microbes (Edwards et al., 2006). Nutrient enrichment is therefore indicative of the direct (Aly & Dadd, 1989) and indirect (Merritt et al., 1992) food availability. The species-specific effects of eutrophication on mosquitoes have been well documented (Buxton et al., 2020a; Krol et al., 2019; Schrama et al., 2018), and *Cx. pipiens* has previously been described to prefer high eutrophication levels (Hasselschwert & Rockett, 1988; Rejmánková et al., 2013). However, these studies commonly simplify eutrophication as food availability, without considering its interactions with larval density and temperature (Edwards et al., 2006), which were tested in **Chapter 2**. The results of **Chapter 2** confirm that *Cx. pipiens* has a strong preference for the most eutrophic state if presented with a gradient

from oligotrophic to hypertrophic conditions during oviposition behavior. While temperature did not interactively affect development and survival, eutrophication and larval density did interact inversely (**Chapter 2**). This suggests that temperature and associated microbial activity did not reduce resource competition at the time scale tested. Depth of the habitat, affecting temperature fluctuations, will therefore be unlikely to affect food availability, meaning that permanent and ephemeral water bodies should be considered equally, based on their eutrophic level. As eutrophication continues to rise globally (Smith et al., 2006), it continues to be one of the most important underlying drivers of *Cx pipiens* abundance. Countering these effects should therefore receive priority if the goal is to lower the abundance of *Cx pipiens*.

Unlike eutrophication, salinization is typically considered detrimental to freshwater organisms (Dahl, 1956). While several physical adaptations in salt water tolerant mosquitoes exist (Akhter et al., 2017; Donini et al., 2007), *Cx. pipiens* is mostly limited to regulation of drinking rate and active secretion (Aly & Dadd, 1989; Bradley, 1987; Bradley & Phillips, 1976). Consequently, *Cx. pipiens* is relatively vulnerable to salinization (Figueroa et al., 2016; Kengne et al., 2019). Analysis on the Dutch populations in **Chapter 4**, however, revealed a higher tolerance than expected, which I hypothesize is caused by gradual historical exposure (Oude Essink et al., 2010; van Baaren & Oude Essink, 2009). Additionally, an interaction between temperature and salinity delayed development under brackish conditions (**Chapter 2**), implying that the increased active expulsion of ions under higher temperatures may have impacted larval energy budget. As a result, salinization is unlikely to affect *Cx. pipiens* populations directly, unless in ephemeral water bodies which may experience higher maximum temperatures. Overall, these findings suggest that abundances of *Cx. pipiens* will likely (locally) increase with increasing salinization, but more work is needed to understand the full implications of this stressor.

Micro-climate is a result of the interplay between the landscape characteristics macro-climate, vegetation cover and spatial habitat structure. From the point of view of mosquito larvae, several elements of the microclimate are rather unimportant, including light intensity and dissolved oxygen (Muturi et al., 2008; Vezzani & Albicocco, 2009) while (fluctuations in) temperature are considered very important (Beck-Johnson et al., 2017; De Majo et al., 2019; Vajedsamiei et al., 2021). In this work, we show that including temperature fluctuations, both natural and through block-schemes, similarly reduced development time by approximately one third compared to a constant temperature of the same mean (**Chapters 2 and 3**). Additionally, the majority of this difference arises during pupation (**Chapter 3**). As pupae do not eat (Becker et al., 2010), suboptimal development under static temperatures may then result in mosquitoes of decreased fitness.

This highlights the importance of including natural fluctuations, in experimental work and modelling practices on climatic effects in vector ecology.

Overall, the ecological interactions at the micro habitat scale underscore the importance of these regulating factors, and potential interactions with larval density but no interactions with the facets of micro-climate, such as temperature. Moreover, these findings underscore that, at the micro-habitat scale, the handling perspective should be geared towards reducing the impact of isolated stressors by mitigating anthropogenic disturbance (e.g. limiting eutrophication by decoupling the water table near agriculture).

### 6.3.2 mesohabitat

The biotope – the system of biotic interactions within the larvae their spatial range – is here defined as the mesohabitat . This scale is defined by the impact of biotic interactions, for example the impact of competitors and predators (Braks et al., 2004; Knight et al., 2004; Murrell & Juliano, 2008).

Due to the surface-dwelling nature of mosquito larvae, reliance on atmospheric instead of dissolved oxygen (Muturi et al., 2008), and the preference of *Cx. pipiens* for semi-temporary water bodies (Becker et al., 2010), most competition originates from other mosquito larvae (Becker et al., 2010). This may be simplified to density dependency effects for competition within the same species (Beck-Johnson et al., 2013; Couret & Benedict, 2014). Such intraspecific competition mainly impacts development, as extremely small amounts of resources are needed for survival (**Chapter 2**). Competition mostly delays development (**Chapter 2**), but high densities may promote early maturation (Knight et al., 2004; Meyabeme Elono et al., 2018), predominantly in males (Alcalay et al., 2018), to escape competition. However, since mosquitoes actively select for eutrophic habitats (Buxton et al., 2020a; Hasselschwert & Rockett, 1988), with low competition (Mwingira et al., 2020), such conditions are unlikely to exist naturally.

Predation is one of the strongest selective forces, directly limiting survival (Culler & Lamp, 2009; DuRant & Hopkins, 2008; Knight et al., 2004; Kovács et al., 2014). Although many predators potentially consider mosquito larvae as prey, the range of actual predators on *Cx. pipiens* may be far more limited, due to the preference of *Cx. pipiens* for ephemeral water bodies. This implies that any potential predator needs to be able to disperse over land or through the air. The preference of *Cx. pipiens* for highly eutrophic water, which is generally related to higher turbidity and low concentrations of dissolved oxygen (Coffin et al., 2021), may further limit the range of predators to those able to breathe atmospheric oxygen and hunt with decreased vision. Based on these notions, **Chapter 5** dove into the species that may be successful predators of mosquito larvae. All

selected predator species were competent antagonists of *Cx. pipiens*. Among these common predator groups, amphibians outperformed all other groups on an individual level, irrespective of eutrophication levels (**Chapter 5**). Facilitating (amphibian) predator presence may therefore prove to be a valuable nature-based solution to limit mosquito presence, as the living community affect habitat suitability both directly and indirectly.

### 6.3.3 landscape

The landscape is defined here as one or multiple habitats and their immediate surroundings. Landscape characteristics may then consist of pressures over multiple habitats, including detritus type (Murrell & Juliano, 2008), soil type (Krol et al., 2023), vegetation (Laporta & Sallum, 2014; Medeiros-Sousa et al., 2017) and macro-climatic conditions such as temperature (Ciota et al., 2014).

Although effects of pressures at a landscape level, such as mean temperature and nitrogen deposition, may impact mosquito larvae directly (**Chapter 2**), I propose that the majority of landscape-wide effects occur during ovipositing. Namely, we find that female mosquitoes actively evade habitats where their offspring has a low chance of survival, and select for environments where the contrary is the case (**Chapters 2, 4 and 5**), contrasting literature on other mosquito species indicating that ovipositing may be decoupled from potential larval survival (Roberts, 1996; Roberts & Irving-Bell, 1997; Yee et al., 2020). Our findings show that habitat selection during egg-laying may be affected by poor water quality (**Chapter 4**), limited resources (**Chapter 2**) or predation (**Chapter 5**). In the latter case, habitats close to those deemed unfavorable are evaded as well (**Chapter 5**). However, even though some habitats are avoided, ovipositing does take place at the comparatively 'most suitable' habitat (Kennedy, 1942). Perceived habitat quality thus seems to be dependent on water quality, resource availability and community structure (mainly competitors and predators) on a case-by-case basis. At the landscape level, these choices are affected by spatial context. I.e., larval habitats that may seem to be poor choices individually, may be the best option available, and therefore may still be colonized depending on the context.

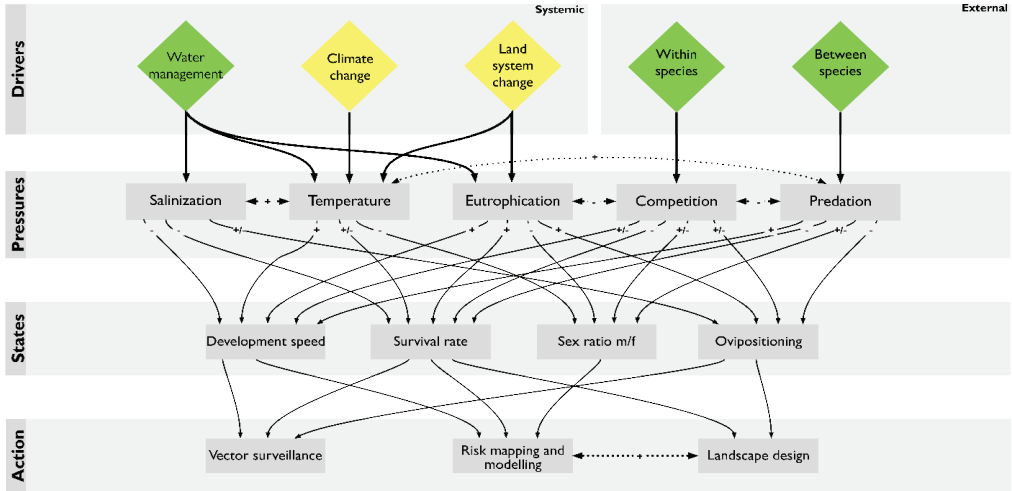
## 6.4 Implementing realism in experimental design

Considering the abovementioned spatial scales of environmental complexity can help to determine how ecological realism may be incorporated into experiments, by providing context and relevance for its different facets. To address the complexities, ecological realism is here subdivided into stressor interactions, spatiotemporal ranges and treatment application. These aspects recognize the complexity of ecological systems, by acknowledging 1) the multifaceted nature of ecological systems, 2) the variability and often cyclic nature of ecological stress over time and space and 3) the unintended potential of experimental conditions modifying stressor impact.

### 6.4.1 Stressor interactions

Stressors have distinct direct impacts on mosquito populations (section 6.3), but there may be several indirect interactive effects as well. Stressors rarely operate in isolation (**Chapter 2**), and often co-occur (Figure 6.2), highlighting the importance of considering potential interactions among stressors. These interactions may occur within a spatial scale, as with competition and predation (Knight et al., 2004), or act across them, e.g., temperature often interacts with pollutants like salts (**Chapter 2**) and pesticides (Muturi et al., 2011). Inter-scale interactions are particularly noteworthy when evaluating interspecies dynamics, where antagonists are often subject to the same stressors, but with different tolerances. For example, predation may interact with eutrophication (Krol et al., 2019), salinity levels (Silberbush et al., 2014), temperature (Lundkvist et al., 2003) and habitat complexity (Buxton et al., 2020c). Similarly, competition can be impacted by temperature (Costanzo et al., 2005), vegetation (Laporta & Sallum, 2014) and detritus (Murrell & Juliano, 2008).

Unintended stressor interactions may also occur, as many stressor impacts are density dependent. Alcalay (2018) found that larval density interacted with temperature and dissolved solute concentration – an indicator for evaporation – increasing development time and lowering survival rates. Alto (2012) found an additional interaction between density and nutrition, increasing male to female sex-ratio, consistent with our findings regarding food availability (**Chapter 2**). Larval densities may therefore be an often implicit, but potential confounding factor. Chosen densities should therefore be consciously evaluated, even when effects of density dependence were not directly evaluated. The same holds true for interactive effects with temperature, for which effects of fluctuations remain underrepresented. Therefore, it is crucial to consider interactive effects, intended and unintended, for accurate assessment of processes acting on mosquito populations.



**Figure 6.2** Overview of systemic and external drivers on abiotic pressures and its impacts on downstream population parameters of mosquitoes. For each of the established impacts between pressures and states, it is indicated whether the association is positive (+), negative (-) or both (+/-).

### 6.4.2 Spatiotemporal ranges

Including spatial and temporal variation in stressor levels is crucial for realistic experimental outcomes. Temporally, different types of stressors act within differing time frames. Ranges of top-down stressors acting on habitat level may be assessed relatively quickly. For instance, predation pressure acts over several days (**Chapter 5**), while competitive and micro-climatic effects impact mosquito larvae over several weeks (**Chapter 2**). Microhabitat stressors, such as chemical pollutants, however, may affect mosquitoes differently across various life stages (Clark et al., 2004, **Chapters 2 and 4**), and potentially across generations, as demonstrated for ecotoxicological effects on other organisms (Nederstigt et al., 2022; Tran et al., 2018). However, most current mosquito experiments evaluate direct toxicity for single stressors on single life stages (Kengne et al., 2019), while multigenerational experiments with changing or transient stressors remain scarce. This is problematic, as valuable information on stressor impact is then lost. Both for life stage dependent sensitivity, and for temporal changes in toxicity, due to gradual increases in exposure (Mottram et al., 1994), changes in bio-availability (Schleier III & Peterson, 2013) and degradation of pollutants (David et al., 2001).



Spatially, chemical and climatic stressors display stratification. Effective treatments and measurements should therefore be tailored to the location in the water column that mosquito larvae predominantly inhabit, typically the water surface (**Chapters 2, 3 and 4**). Consequently, measuring stressors like temperature at higher depths, or using air temperature as indicator, misrepresents actual surface water temperatures, and may thereby cause inaccurate results (Asare et al., 2016; Paaijmans et al., 2008). However, up until recently, using air temperatures has been the norm for modelling practices (Asare et al., 2016; Erraguntla et al., 2021). Biotic interactions are similarly stratified, as effects of competition or predation may be limited if the antagonist resides in a different layer (section 6.3.2), or when a competitor uses different feeding methods (Merritt et al., 1992). Chemical stressors may express differing levels of bioavailability depending on the place in the water column, as polar substances like pyrethrins can bind to sediment (Schleier III & Peterson, 2013), depending on the (controlled-release) formulation used (Andriessen et al., 2015; Mapossa et al., 2021). As such, relevant timeframes and spatio-temporal processes should be evaluated to inform realistic stressor application.

### 6.4.3 *Treatment application and relevance*

Realistic application of treatments relies on the principles from realistic stressor interactions and ranges as well as the relevant spatial scale. For instance, landscape characteristics such as vegetation should be considered when evaluating predation, as vegetation may interact by providing a resting spot for predators (**Chapter 5**), as well as by creating a predator refuge (Bond et al., 2005). When simulating the micro-climate, natural fluctuations should be considered. For example, natural temperatures are cyclic in nature, and their inclusion may severely impact population parameters (**Chapter 3**). Such spatiotemporal changes in exposure are important for chemical stress as well, as reported by Viaene (2016).

When considering the relevance of particular stressor treatments, it is important to consider the populations used. The historical context of populations should therefore be evaluated and reported when assessing effects of stressors which may have caused local adaptations. For instance, Kengne (2019) reported on salinity tolerance of multigenerational lab populations originating from Cévenne, France, explicitly mentioning potential bias as a result of local adaptations and inbreeding depression. Differences in historical exposure may indeed partially explain the large discrepancy in tolerance found for Dutch populations (**Chapter 4**), stressing the importance of communicating and contextualizing geographic

origin. Finally, the relevance of each treatment should be evaluated by assessing colonization by the relevant species (**Chapters 2, 4 and 5**). Information on habitat preferences for colonization and its potential discrepancies with other population parameters may inform whether certain conditions may create population sinks, potential hotspots, cause dispersal or will simply not affect populations.

### 6.5 Future strategic research areas

In my analysis of the main anthropogenic drivers of *Cx. pipiens* population dynamics, I have strived to be as complete as possible within the limits of a 4-year PhD project. However, some areas of research were not evaluated, even though they do require further testing. These include an evidence-based link between mosquito population dynamics and disease risk, community evaluation of salinization impacts and generalization of the found impacts for other mosquito species. In doing so, the current findings could more easily and accurately be applied to mosquito-borne disease preparedness.

A major and consistent assumption in the field of vector ecology, mine including, regards the translation of population dynamics to disease risk. Namely, it is assumed that these stressors not only affect mosquito abundances, but thereby also modify the probability of transmission, and hence influence disease dynamics and ultimately disease risk. There is some emerging evidence that modifying mosquito abundances indeed influence transmission (Kolimenakis et al., 2021), but a lot on this topic is still unknown. Vector-borne diseases, by definition, are limited to transmission by their vector, but information on the minimum viable vector density, is scarce. This is caused by a disconnect with vector-host dynamics, for which a framework has only recently been established (Thongsripong et al., 2021), which highlights that additional information is needed on (stressor impacts on) human-mosquito contact rates. Such information should include stressor impact on dispersal capacity, biting rates and biting behavior (Thongsripong et al., 2021). This could then be combined with information on the impacts of growth conditions on vector competence (Esser et al., 2019) to assess vector-borne disease risk semi-quantitatively (Petrić et al., 2014).

This thesis provides some indications that coastal areas experiencing ongoing salinization may be potential risk sites for disease transmission. Central to this idea are the assumptions that predation might become lower in these areas and that *Cx. pipiens* willingly colonizes saline water bodies. These factors should

be evaluated further. Firstly, the impacts of ongoing salinization on mosquito predator communities should be assessed either experimentally or by field survey to determine whether freshwater predators show similar plasticity or adaptations or whether alternative predator species take their place. Secondly, egg-laying behavior during the salinization experiments used freshwater bacterial communities, which were self-selected during acclimatization. Although these self-selected community and their medium attracted gravid mosquitoes up to moderate salinities, bacterial activity may have been limiting egg laying behavior under the most saline conditions. In the light of ongoing salinization, further evaluation is needed to understand this mechanism, as even higher salinities may prove to be sufficiently 'attractive' when using bacterial communities natural to these areas.

And last but not least, the hypotheses in this thesis should be evaluated for other mosquito species to test their generality. Although the processes on which the stressors and their interactions act should be comparable across species, whether their relative importance remains the same, remains to be tested.

### 6.6 Implications in a one health context

One of the aims of this thesis was to identify the main anthropogenic drivers impacting *Cx. pipiens* its population dynamics (Figure 6.2), to support the development of practical tools, approaches and risk-assessment in One Health PACT to intervene in, and enhance preparedness against, mosquito-borne outbreaks in a changing world. The work presented in this thesis describes anthropogenic impacts at three habitat scales. Each scale is impacted by a combination of stressors that will shape the size and structure of mosquito populations. Similarly, each scale contains a set of these parameters that could be acted on as potential interventions for risk of pathogen transmission, either directly harnessing stressor impact, or by using relevant interactions.

Most traditional interventions act as bottom-up stressors at the microhabitat scale, encompassing common insecticides, either as chemical compound (i.e. DDT), or as bacterium producing larvicidal compounds (Bti) (Geetha & Manonmani, 2008; Rochlin et al., 2016). However, these are short-term interventions, as they impact the population size, but not the habitat quality, thereby allowing for recolonization as soon as the effectivity has faded (Benelli et al., 2016). Because of this, as well as concerns with increasing insecticide resistances, interventions

at the mesohabitat scale are gaining increasing attention (Abagli & Alavo, 2019; Chen et al., 2005; Kumar & Hwang, 2006). By employing mosquito predators as biocontrol agents as reinforcement or standalone. In doing so mosquito populations may be suppressed for longer periods (Talaga et al., 2020). Using predator assemblages further improve effectivity (Buxton et al., 2020b), potentially limiting confounding effects of habitat complexity as well (Buxton et al., 2020c). These effects at landscape scale should inform which (combination of) predator species could most effectively limit mosquito populations, by assessing their mobility within the water body (Alto et al., 2005; Buxton et al., 2020c) as well as dispersal capacity across water bodies (Brodman & Dorton, 2006; Raghavendra et al., 2007; **Chapter 5**). In doing so, natural dispersal may be facilitated so that mosquito habitat suitability is definitively decreased. This may provide a more long-term and less challenging method to be exhaustively achieved compared to local interventions like draining standing water, or luring gravid mosquitoes, as has been proposed by Wong (2012).

Although the current thesis insinuates that predator free, (anthropogenically) disturbed habitats are the most conducive to mosquito populations (**Chapters 2-5**), it is unclear how well these results translate to more ecologically complex habitats. The currently used mesocosms are the preferred habitat for *Cx. pipiens* (Becker et al., 2010), but more complex habitats are known to be colonized as well (Krol et al., 2023). Similarly, without information on the link between mosquito population dynamics and disease transmission (Section 6.5), it is impossible to make any definitive statements on future disease risk based on the current results. The information in this thesis can however give indications on how to identify potential hotspots by their abiotic conditions and ecological community, thereby allowing effective interventions when outbreaks do occur. Similarly, it is currently impossible to state the extent to which mosquito populations should be managed to prevent outbreaks. Nevertheless, the findings within this thesis do support the notion that potential hotspots may be preempted by facilitating healthy ecosystems at or near the site.

## 6.7 Conclusion

In this thesis, I argue that integrating ecological realism into infectious disease studies, is crucial to develop more effective strategies. This includes recognizing interactions across microhabitat, habitat and landscape scales, and incorporating realistic stressor interactions, ranges and treatment application, as described

in this thesis. To this end, I have chosen a spatial and systems-based approach, following from the principles of One Health. I have shown that stressors interact across all three spatial scales, affecting *Cx. pipiens* in its natural habitat, not in isolation from its habitat. I have shown that several stressors have impacts reaching further than commonly evaluated impacts, especially when including realistic application. Additionally, I have shown that changes in climate often interact with other anthropogenic impacts and should therefore be evaluated conjunctly. This thesis shows that more care should be taken to include ecological realism for accurate and relevant results that reach further than their experimental setting. Especially within holistic and multidisciplinary frameworks like One Health, where interactions are the norm.

These results give an overview of the main anthropogenic drivers, and their interactions, acting on *Cx. pipiens* population dynamics, thereby laying the foundation for predictions of how their populations will shift with our changing world. Similarly, this thesis provides insight in the drivers that effective interventions should act on. This lays a basis for proactive mitigation of *Culex*-borne disease risk, by furthering our understanding of human impacts on *Cx. pipiens*. Further scientific endeavors are needed to extend these findings to other species.





References

## References

## References

---

- Abagli, A. Z., & Alavo, T. B. C. (2019). Biocontrol of *Culex quinquefasciatus* using the insect parasitic nematode, *Romanomermis iyengari*. *Tropical Biomedicine*, 36(4), 1003–1013.
- Abella-Medrano, C. A., Ibáñez-Bernal, S., MacGregor-Fors, I., & Santiago-Alarcon, D. (2015). Spatiotemporal variation of mosquito diversity (Diptera: *Culicidae*) at places with different land-use types within a neotropical montane cloud forest matrix. *Parasites & Vectors*, 8(1), 487. <https://doi.org/10.1186/s13071-015-1086-9>
- Abou-Attia, F. A., El-Khodary, A. S., Metwally, S. M. I., & Hassan, H. M. (2000). Monthly fluctuations of larval and pupal densities of *Culex pipiens* (L.) with special reference to the effect of aquatic physiochemical properties on their habitats at kafr el-sheikh region. *Journal of Plant Protection and Pathology*, 25(4), 2377–2386.
- Abrahams, M. V., & Kattenfeld, M. G. (1997). The role of turbidity as a constraint on predator-prey interactions in aquatic environments. *Behavioral Ecology and Sociobiology*, 40(3), 169–174. <https://doi.org/10.1007/s002650050330>
- Adams, H. E., Crump, B. C., & Kling, G. W. (2010). Temperature controls on aquatic bacterial production and community dynamics in arctic lakes and streams. *Environmental Microbiology*, 12(5), 1319–1333. <https://doi.org/10.1111/j.1462-2920.2010.02176.x>
- Adegoke, J. O., Pielke, R., & Carleton, A. M. (2007). Observational and modeling studies of the impacts of agriculture-related land use change on planetary boundary layer processes in the central U.S. *Agricultural and Forest Meteorology*, 142(2–4), 203–215. <https://doi.org/10.1016/j.agrformet.2006.07.013>
- Agnew, P., Haussy, C., & Michalakis, Y. (2000). Effects of Density and Larval Competition on Selected Life History Traits of *Culex pipiens quinquefasciatus* (Diptera: *Culicidae*). *Journal of Medical Entomology*, 37(5), 732–735. <https://doi.org/10.1603/0022-2585-37.5.732>
- Akanda, A. S., Johnson, K., Ginsberg, H. S., & Couret, J. (2020). Prioritizing Water Security in the Management of Vector-Borne Diseases: Lessons From Oaxaca, Mexico. *GeoHealth*, 4(3), e2019GH000201. <https://doi.org/10.1029/2019GH000201>
- Akhter, H., Misyura, L., Bui, P., & Donini, A. (2017). Salinity responsive aquaporins in the anal papillae of the larval mosquito, *Aedes aegypti*. *Comparative Biochemistry and Physiology Part A: Molecular & Integrative Physiology*, 203, 144–151. <https://doi.org/10.1016/j.cbpa.2016.09.008>

- Akiner, M., & Eksi, E. (2015). Influence of five different larval control agents on oviposition of *Culex pipiens* L. (Diptera: Culicidae). *Journal of the European Mosquito Control Association*, 33, 5–9.
- Alcalay, Y., Puzhevsky, D., Tsurim, I., Scharf, I., & Ovadia, O. (2018). Interactive and sex-specific life-history responses of *Culex pipiens* mosquito larvae to multiple environmental factors. *Journal of Zoology*, 306(4), 268–278. <https://doi.org/10.1111/jzo.12611>
- Alcalay, Y., Tsurim, I., & Ovadia, O. (2019). Multi-scale oviposition site selection in two mosquito species: Multi-scale habitat selection in mosquitoes. *Ecological Entomology*, 44(3), 347–356. <https://doi.org/10.1111/een.12708>
- Al-Doghairi, M., El-Nadi, A., Elhag, E., & Al-Ayedh, H. (2004). Effect of *Solenostemma argel* on oviposition, egg hatchability and viability of *Culex pipiens* L. larvae. *Phytotherapy Research*, 18(4), 335–338. <https://doi.org/10.1002/ptr.1432>
- Allgeier, S., Friedrich, A., & Brühl, C. A. (2019). Mosquito control based on *Bacillus thuringiensis israelensis* (Bti) interrupts artificial wetland food chains. *Science of The Total Environment*, 686, 1173–1184. <https://doi.org/10.1016/j.scitotenv.2019.05.358>
- Alto, B. W., Griswold, M. W., & Lounibos, L. P. (2005). Habitat complexity and sex-dependent predation of mosquito larvae in containers. *Oecologia*, 146(2), 300–310. <https://doi.org/10.1007/s00442-005-0198-x>
- Alto, B. W., Malicoate, J., Elliott, S. M., & Taylor, J. (2012). Demographic Consequences of Predators on Prey: Trait and Density Mediated Effects on Mosquito Larvae in Containers. *PLOS ONE*, 7(11), e45785. <https://doi.org/10.1371/journal.pone.0045785>
- Alto, B. W., Muturi, E. J., & Lampman, R. L. (2012). Effects of nutrition and density in *Culex pipiens*. *Medical and Veterinary Entomology*, 26(4), 396–406. <https://doi.org/10.1111/j.1365-2915.2012.01010.x>
- Aly, C., & Dadd, R. H. (1989). Drinking rate regulation in some fresh-water mosquito larvae. *Physiological Entomology*, 14(3), 241–256.
- Anamaria, D., Diana, C., Oana, H., & Andrea, E. (2011). Food composition of a *Lissotriton vulgaris* Linnaeus 1758 (Amphibia) population from Vadu Crişului, Bihor County, Romania. *Bogdan Stugren, Volum comemorativ*, 100–106.

## References

---

- Anand, M., Gonzalez, A., Guichard, F., Kolasa, J., & Parrott, L. (2010). Ecological Systems as Complex Systems: Challenges for an Emerging Science. *Diversity*, 2(3), 395–410. <https://doi.org/10.3390/d2030395>
- Ansa-Asare, O. D., Marr, I. L., & Cresser, M. S. (2000). Evaluation of modelled and measured patterns of dissolved oxygen in a freshwater lake as an indicator of the presence of biodegradable organic pollution. *Water Research*, 34(4), 1079–1088. [https://doi.org/10.1016/S0043-1354\(99\)00239-0](https://doi.org/10.1016/S0043-1354(99)00239-0)
- Antwi, F. B., & Reddy, G. V. P. (2015). Toxicological effects of pyrethroids on non-target aquatic insects. *Environmental Toxicology and Pharmacology*, 40(3), 915–923. <https://doi.org/10.1016/j.etap.2015.09.023>
- Aryaprema, V. S., Steck, M. R., Peper, S. T., Xue, R., & Qualls, W. A. (2023). A systematic review of published literature on mosquito control action thresholds across the world. *PLOS Neglected Tropical Diseases*, 17(3), e0011173. <https://doi.org/10.1371/journal.pntd.0011173>
- Asakura, K. (1980). The anal portion as a salt-excreting organ in a seawater mosquito larva, *Aedes togoi* Theobald. *Journal of Comparative Physiology ? B*, 138(1), 59–65. <https://doi.org/10.1007/BF00688736>
- Asare, E. O., Tompkins, A. M., Amekudzi, L. K., Ermert, V., & Redl, R. (2016). Mosquito breeding site water temperature observations and simulations towards improved vector-borne disease models for Africa. *Geospatial Health*, 11(s1), Article s1. <https://doi.org/10.4081/gh.2016.391>
- Awasthi, A. K., Wu, C.-H., & Hwang, J.-S. (2012). Diving as an Anti-Predator Behavior in Mosquito Pupae. *Zoological Studies*, 51(8), 10. <http://zoolstud.sinica.edu.tw/Journals/51.8/1225.pdf>
- Balasubramanian, R., Sahina, S., Nadh, V. A., Sreelekha, K. P., & Nikhil, T. L. (2019). Effects of different salinity levels on larval growth and development of disease vectors of *Culex* species. *Journal of Environmental Biology*, 40(5), 1115–1122. <https://doi.org/10.22438/jeb/40/5/MRN-950>
- Banahene, N., Salem, S. K., Faske, T. M., Byrne, H. M., Glackin, M., Agosta, S. J., Eckert, A. J., Grayson, K. L., & Thompson, L. M. (2018). Thermal Sensitivity of Gypsy Moth (Lepidoptera: Erebididae) During Larval and Pupal Development. *Environmental Entomology*, 47(6), 1623–1631. <https://doi.org/10.1093/ee/nvy149>

- Barausse, A., Michieli, A., Riginella, E., Palmeri, L., & Mazzoldi, C. (2011). Long-term changes in community composition and life-history traits in a highly exploited basin (northern Adriatic Sea): The role of environment and anthropogenic pressures. *Journal of Fish Biology*, 79(6), 1453–1486. <https://doi.org/10.1111/j.1095-8649.2011.03139.x>
- Barmentlo, S. H., Schrama, M., Hunting, E. R., Heutink, R., van Bodegom, P. M., de Snoo, G. R., & Vijver, M. G. (2018). Assessing combined impacts of agrochemicals: Aquatic macroinvertebrate population responses in outdoor mesocosms. *Science of The Total Environment*, 631–632, 341–347. <https://doi.org/10.1016/j.scitotenv.2018.03.021>
- Bauer, J., Börsig, N., Pham, V. C., Hoan, T. V., Nguyen, H. T., & Norra, S. (2022). Geochemistry and evolution of groundwater resources in the context of salinization and freshening in the southernmost Mekong Delta, Vietnam. *Journal of Hydrology: Regional Studies*, 40, 101010. <https://doi.org/10.1016/j.ejrh.2022.101010>
- Bayoh, M. N., & Lindsay, S. W. (2004). Temperature-related duration of aquatic stages of the Afrotropical malaria vector mosquito *Anopheles gambiae* in the laboratory. *Medical and Veterinary Entomology*, 18(2), 174–179. <https://doi.org/10.1111/j.0269-283X.2004.00495.x>
- Becker, D. J., Washburne, A. D., Faust, C. L., Pulliam, J. R. C., Mordecai, E. A., Lloyd-Smith, J. O., & Plowright, R. K. (2019). Dynamic and integrative approaches to understanding pathogen spillover. *Philosophical Transactions of the Royal Society B: Biological Sciences*, 374(1782), 20190014. <https://doi.org/10.1098/rstb.2019.0014>
- Becker, N., Dahl, C., Bryant, B., Blair, C. D., Olson, K. E., Clem, R. J., Minard, G., Mavingui, P., Moro, C. V., Foster, W. a, Buchon, N., Broderick, N. a, Chakrabarti, S., Lee, W., Lemaitre, B., Engel, P., Moran, N. A., Li, Y., Hernandez-Martinez, S., ... Kaslow, D. C. (2013). Mosquitoes and their control. In *Insect Biochemistry and Molecular Biology* (Vol. 33). Springer Berlin Heidelberg. <https://doi.org/10.1101/gad.1827009>
- Becker, N., Petric, D., Zgomba, M., Boase, C., Madon, M., Dahl, C., & Kaiser, A. (2010). *Mosquitoes and Their Control* (2nd ed., Vol. 1). Springer Berlin Heidelberg. <https://doi.org/10.1007/978-3-540-92874-4>
- Beck-Johnson, L. M., Nelson, W. A., Paaijmans, K. P., Read, A. F., Thomas, M. B., & Bjørnstad, O. N. (2013). The Effect of Temperature on *Anopheles* Mosquito Population Dynamics and the Potential for Malaria Transmission. *PLoS ONE*, 8(11), e79276. <https://doi.org/10.1371/journal.pone.0079276>

## References

---

- Beck-Johnson, L. M., Nelson, W. A., Paaijmans, K. P., Read, A. F., Thomas, M. B., & Bjørnstad, O. N. (2017). The importance of temperature fluctuations in understanding mosquito population dynamics and malaria risk. *Royal Society Open Science*, 4(3), 160969. <https://doi.org/10.1098/rsos.160969>
- Beck-Johnson, L. M., Nelson, W. A., Paaijmans, P., Read, A. F., & Bjørnstad, O. N. (2017). Population dynamics and malaria risk. *Royal Society*, 4, 11. <https://doi.org/10.6084/m9.figshare.c.3703528>.
- Behrens, W., Hoffmann, K.-H., Kempa, S., Gäbler, S., & Merkel-Wallner, G. (1983). Effects of diurnal thermoperiods and quickly oscillating temperatures on the development and reproduction of crickets, *Gryllus bimaculatus*. *Oecologia*, 59(2–3), 279–287. <https://doi.org/10.1007/BF00378849>
- Beketov, M. A., & Liess, M. (2007). Predation risk perception and food scarcity induce alterations of life-cycle traits of the mosquito *Culex pipiens*. *Ecological Entomology*, 32(4), 405–410. <https://doi.org/10.1111/j.1365-2311.2007.00889.x>
- Belén Arias, M., Josefina Poupin, M., & Lardies, M. A. (2011). Plasticity of life-cycle, physiological thermal traits and Hsp70 gene expression in an insect along the ontogeny: Effect of temperature variability. *Journal of Thermal Biology*, 36(6), 355–362. <https://doi.org/10.1016/j.jtherbio.2011.06.011>
- Benelli, G. (2015). Research in mosquito control: Current challenges for a brighter future. *Parasitology Research*, 114(8), 2801–2805. <https://doi.org/10.1007/s00436-015-4586-9>
- Benelli, G., Jeffries, C. L., & Walker, T. (2016). Biological Control of Mosquito Vectors: Past, Present, and Future. *Insects*, 7(4), Article 4. <https://doi.org/10.3390/insects7040052>
- Bentley, M. D. (1989). Chemical Ecology and Behavioral Aspects of Mosquito Oviposition. *Annual Reviews Entomology*, 34, 401–421.
- Bissattini, A. M., Haubrock, P. J., Buono, V., Balzani, P., Borgianni, N., Stellati, L., Inghilesi, A. F., Tancioni, L., Martinoli, M., Tricarico, E., & Vignoli, L. (2021). Trophic structure of a pond community dominated by an invasive alien species: Insights from stomach content and stable isotope analyses. *Aquatic Conservation: Marine and Freshwater Ecosystems*, 31(4), 948–963. <https://doi.org/10.1002/aqc.3530>

- Bleich, S., Powilleit, M., Seifert, T., & Graf, G. (2011).  $\beta$ -diversity as a measure of species turnover along the salinity gradient in the Baltic Sea, and its consistency with the Venice System. *Marine Ecology Progress Series*, 436, 101–118. <https://doi.org/10.3354/meps09219>
- Blommers-Schlösser, R. M. A. (1992). De groene 'kickers in Nederland; samenstelling van populaties, oecologk, i. *De Levende Natuur*, 93(1), 2–9. <https://natuurtijdschriften.nl/pub/494787/DLN0930020091.pdf>
- Boerlijst, S. P., Johnston, E. S., Ummels, A., Krol, L., Boelee, E., van Bodegom, P. M., & Schrama, M. J. J. (2023). Biting the hand that feeds: Anthropogenic drivers interactively make mosquitoes thrive. *Science of The Total Environment*, 858, 159716. <https://doi.org/10.1016/j.scitotenv.2022.159716>
- Bolanakis, D. E. (2019). A Survey of Research in Microcontroller Education. *IEEE Revista Iberoamericana de Tecnologías Del Aprendizaje*, 14(2), 50–57. <https://doi.org/10.1109/RITA.2019.2922856>
- Bond, J. G., Arredondo-Jimenez, J. I., Rodriguez, M. H., Quiroz-Martinez, H., & Williams, T. (2005). Oviposition habitat selection for a predator refuge and food source in a mosquito. *Ecological Entomology*, 30(3), 255–263. <https://doi.org/10.1111/j.0307-6946.2005.00704.x>
- Bonte, M., & Zwolsman, J. J. G. (2010). Climate change induced salinisation of artificial lakes in the Netherlands and consequences for drinking water production. *Water Research*, 44(15), 4411–4424. <https://doi.org/10.1016/j.watres.2010.06.004>
- Borchers, H. W. (2022). *pracma: Practical Numerical Math Functions*. <https://CRAN.R-project.org/package=pracma>
- Boualam, M. A., Pradines, B., Drancourt, M., & Barbieri, R. (2021). Malaria in Europe: A Historical Perspective. *Frontiers in Medicine*, 8. <https://doi.org/10.3389/fmed.2021.691095>
- Bowler, K. (2018). Heat death in poikilotherms: Is there a common cause? *Journal of Thermal Biology*, 76, 77–79. <https://doi.org/10.1016/j.jtherbio.2018.06.007>
- Bradley, T. J. (1987). Physiology of Osmoregulation in Mosquitoes. *Annual Review of Entomology*, 32(1), 439–462. <https://doi.org/10.1146/annurev.en.32.010187.002255>

## References

---

- Bradley, T. J., & Phillips, J. E. (1976). *The Effect Of External Salinity On Drinking Rate And Rectal Secretion In The Larvae Of The Saline-Water Mosquito*. 14. <https://doi.org/10.1242/jeb.66.1.97>
- Braganza, K., Karoly, D. J., & Arblaster, J. M. (2004). Diurnal temperature range as an index of global climate change during the twentieth century: DTR AS CLIMATE CHANGE INDEX. *Geophysical Research Letters*, 31(13), n/a-n/a. <https://doi.org/10.1029/2004GL019998>
- Braks, M. A. H., Honório, N. A., Lounibos, L. P., Lourenço-De-Oliveira, R., & Juliano, S. A. (2004). Interspecific Competition Between Two Invasive Species of Container Mosquitoes, *Aedes aegypti* and *Aedes albopictus* (Diptera: Culicidae), in Brazil. *Annals of the Entomological Society of America*, 97(1), 130–139. [https://doi.org/10.1603/0013-8746\(2004\)097\[0130:ICBTIS\]2.0.CO;2](https://doi.org/10.1603/0013-8746(2004)097[0130:ICBTIS]2.0.CO;2)
- Bravo-Barriga, D., Parreira, R., Almeida, A. P. G., Calado, M., Blanco-Ciudad, J., Serrano-Aguilera, F. J., Pérez-Martín, J. E., Sánchez-Peinado, J., Pinto, J., Reina, D., & Frontera, E. (2016). *Culex pipiens* as a potential vector for transmission of *Dirofilaria immitis* and other unclassified Filarioidea in Southwest Spain. *Veterinary Parasitology*, 223, 173–180. <https://doi.org/10.1016/j.vetpar.2016.04.030>
- Breitschwerdt, E. B. (2014). Bartonellosis: One Health Perspectives for an Emerging Infectious Disease. *ILAR Journal*, 55(1), 46–58. <https://doi.org/10.1093/ilar/ilu015>
- Brodman, R., & Dorton, R. (2006). The Effectiveness of Pond-Breeding Salamanders as Agents of Larval Mosquito Control. *Journal of Freshwater Ecology*, 21(3), Article 3. <https://doi.org/10.1080/02705060.2006.9665024>
- Brown, B. J., & Platzer, E. G. (1978). Salts and the infectivity of *Romanomermis culicivorax*. *Journal of Nematology*, 10(1), 53.
- Brühl, C. A., Després, L., Frör, O., Patil, C. D., Poulin, B., Tetreau, G., & Allgeier, S. (2020). Environmental and socioeconomic effects of mosquito control in Europe using the biocide *Bacillus thuringiensis* subsp. *israelensis* (Bti). *Science of The Total Environment*, 724, 137800. <https://doi.org/10.1016/j.scitotenv.2020.137800>
- Bruno, D. W., & Laurence, B. R. (1979). The Influence of the Apical Droplet of *Culex* Egg Rafts on Oviposition of *Culex pipiens fatigans* (Diptera: Culicidae). *Journal of Medical Entomology*, 16(4), 300–305. <https://doi.org/10.1093/jmedent/16.4.300>
- Brust, R. A., & Kalpage, K. S. (1967). A rearing method for *Aedes abserratus* (F. and Y.). *Mosquito News*, 27(1). <https://www.cabdirect.org/cabdirect/abstract/19672902355>

- Butler, C. D. (2012). Infectious disease emergence and global change: Thinking systemically in a shrinking world. *Infectious Diseases of Poverty*, 1(1), 5. <https://doi.org/10.1186/2049-9957-1-5>
- Buxton, M., Cuthbert, R. N., Dalu, T., Nyamukondiwa, C., & Wasserman, R. J. (2020). Cattle-induced eutrophication favours disease-vector mosquitoes. *Science of The Total Environment*, 715, 136952. <https://doi.org/10.1016/j.scitotenv.2020.136952>
- Buxton, M., Cuthbert, R. N., Dalu, T., Nyamukondiwa, C., & Wasserman, R. J. (2020a). Complementary impacts of heterospecific predators facilitate improved biological control of mosquito larvae. *Biological Control*, 144, 104216. <https://doi.org/10.1016/j.biocontrol.2020.104216>
- Buxton, M., Cuthbert, R. N., Dalu, T., Nyamukondiwa, C., & Wasserman, R. J. (2020b). Predator density modifies mosquito regulation in increasingly complex environments. *Pest Management Science*, 76(6), 2079–2086. <https://doi.org/10.1002/ps.5746>
- Cadmus, P., Pomeranz, J. P. F., & Kraus, J. M. (2016). Low-cost floating emergence net and bottle trap: Comparison of two designs. *Journal of Freshwater Ecology*, 31(4), 653–658. <https://doi.org/10.1080/02705060.2016.1217944>
- Cano-Rocabayera, O., Vargas-Amengual, S., Aranda, C., de Sostoa, A., & Maceda-Veiga, A. (2020). Mosquito larvae consumption in turbid waters: The role of the type of turbidity and the larval stage in native and invasive fish. *Hydrobiologia*, 847(5), 1371–1381. <https://doi.org/10.1007/s10750-020-04195-0>
- Caplan, J. S., Giménez, D., Hirmas, D. R., Brunsell, N. A., Blair, J. M., & Knapp, A. K. (2019). Decadal-scale shifts in soil hydraulic properties as induced by altered precipitation. *Science Advances*, 5(9), eaau6635. <https://doi.org/10.1126/sciadv.aau6635>
- Carlson, J., Keating, J., Mbogo, C. M., Kahindi, S., & Beier, J. C. (2004). Ecological limitations on aquatic mosquito predator colonization in the urban environment. *Journal of Vector Ecology : Journal of the Society for Vector Ecology*, 29(2), 331–339. <https://www.ncbi.nlm.nih.gov/pmc/articles/PMC3705640/>
- Carlson, S. M., Cunningham, C. J., & Westley, P. A. H. (2014). Evolutionary rescue in a changing world. *Trends in Ecology & Evolution*, 29(9), 521–530. <https://doi.org/10.1016/j.tree.2014.06.005>

## References

---

- Ceccatelli, M., Del Soldato, M., Solari, L., Fanti, R., Mannori, G., & Castelli, F. (2021). Numerical modelling of land subsidence related to groundwater withdrawal in the Firenze-Prato-Pistoia basin (central Italy). *Hydrogeology Journal*, 29(2), 629–649. <https://doi.org/10.1007/s10040-020-02255-2>
- Chapman, G. E., Sherlock, K., Hesson, J. C., Blagrove, M. S. C., Lycett, G. J., Archer, D., Solomon, T., & Baylis, M. (2020). Laboratory transmission potential of British mosquitoes for equine arboviruses. *Parasites & Vectors*, 13(1), 413. <https://doi.org/10.1186/s13071-020-04285-x>
- Charalampous, P., Haagsma, J. A., Jakobsen, L. S., Gorasso, V., Noguer, I., Padron-Monedero, A., Sarmiento, R., Santos, J. V., McDonald, S. A., Plass, D., Wyper, G. M. A., Assunção, R., Lippe, E. von der, Ádám, B., AlKerwi, A., Arabloo, J., Baltazar, A. L., Bikbov, B., Borrell-Pages, M., ... Pires, S. M. (2023). Burden of infectious disease studies in Europe and the United Kingdom: A review of methodological design choices. *Epidemiology & Infection*, 151, e19. <https://doi.org/10.1017/S0950268823000031>
- Chen, C.-M., Hsieh, H.-J., Hu, B.-Y., & Fu, C.-H. (2005). Mosquito-killing water molds isolated from soil samples collected in Taiwan. *Pedobiologia*, 49(6), 585–589. <https://doi.org/10.1016/j.pedobi.2005.06.010>
- Cheng, S., Zhang, L., Song, H., & Yu, H. (2011). A soil temperature control system for sapling study in alpine region. *Journal of Mountain Science*, 8(5), 739–749. <https://doi.org/10.1007/s11629-011-1037-7>
- Chidester, F. E. (1916). The Influence of Salinity on the Development of certain Species of Mosquito Larvae and its Bearing on the Problem of the Distribution of Species. *Bulletin. New Jersey Agricultural Experiment Station*, 299.
- Childs, M. L., Nova, N., Colvin, J., & Mordecai, E. A. (2019). Mosquito and primate ecology predict human risk of yellow fever virus spillover in Brazil. *Philosophical Transactions of the Royal Society B: Biological Sciences*, 374(1782), 20180335. <https://doi.org/10.1098/rstb.2018.0335>
- Chown, S. L., & Nicolson, S. (2004). *Insect physiological ecology: Mechanisms and patterns*. Oxford University Press.
- Cianci, D., Hartemink, N., & Ibáñez-Justicia, A. (2015). Modelling the potential spatial distribution of mosquito species using three different techniques. *International Journal of Health Geographics*, 14(1), 10. <https://doi.org/10.1186/s12942-015-0001-0>

- Ciota, A. T., Matacchiero, A. C., Kilpatrick, A. M., & Kramer, L. D. (2014). The Effect of Temperature on Life History Traits of *Culex* Mosquitoes. *Journal of Medical Entomology*, 51(1), 55–62. <https://doi.org/10.1603/ME13003>
- Clark, M. S., & Worland, M. R. (2008). How insects survive the cold: Molecular mechanisms—a review. *Journal of Comparative Physiology B*, 178(8), 917–933. <https://doi.org/10.1007/s00360-008-0286-4>
- Clark, T. M., Flis, B. J., & Remold, S. K. (2004). Differences in the effects of salinity on larval growth and developmental programs of a freshwater and a euryhaline mosquito species (Insecta: Diptera, *Culicidae*). *Journal of Experimental Biology*, 207(13), 2289–2295. <https://doi.org/10.1242/jeb.01018>
- Coffin, M., Knysh, K., Roloson, S., Pater, C., Theriault, E., Cormier, J., Courtenay, S., & van den Heuvel, M. (2021). Influence of nutrient enrichment on temporal and spatial dynamics of dissolved oxygen within northern temperate estuaries. *Environmental Monitoring and Assessment*, 193(12), 804. <https://doi.org/10.1007/s10661-021-09589-8>
- Coffin, M. R. S., Courtenay, S. C., Pater, C. C., & van den Heuvel, M. R. (2018). An empirical model using dissolved oxygen as an indicator for eutrophication at a regional scale. *Marine Pollution Bulletin*, 133, 261–270. <https://doi.org/10.1016/j.marpolbul.2018.05.041>
- Colinet, H., Sinclair, B. J., Vernon, P., & Renault, D. (2015). Insects in Fluctuating Thermal Environments. *Annual Review of Entomology*, 60(1), 123–140. <https://doi.org/10.1146/annurev-ento-010814-021017>
- Colón-González, F. J., Sewe, M. O., Tompkins, A. M., Sjödin, H., Casallas, A., Rocklöv, J., Caminade, C., & Lowe, R. (2021). Projecting the risk of mosquito-borne diseases in a warmer and more populated world: A multi-model, multi-scenario intercomparison modelling study. *The Lancet Planetary Health*, 5(7), e404–e414. [https://doi.org/10.1016/S2542-5196\(21\)00132-7](https://doi.org/10.1016/S2542-5196(21)00132-7)
- Coolidge, J. C. (2017). *Larval Culex Mosquitoes Increase Primary Production and Decrease Bacterial Diversity in Aquatic Mesocosms* [MSc, University of California, Riverside]. <https://escholarship.org/uc/item/8qg9d2ms>
- Costanzo, K. S., Kesavaraju, B., & Juliano, S. A. (2005). Condition-specific competition in container mosquitoes: The role of noncompeting life-history stages. *Ecology*, 86(12), 3289–3295. <https://doi.org/10.1890/05-0583>

## References

---

- Couret, J., & Benedict, M. Q. (2014). A meta-analysis of the factors influencing development rate variation in *Aedes aegypti* (Diptera: *Culicidae*). *BMC Ecology*, 14(1), 3. <https://doi.org/10.1186/1472-6785-14-3>
- Covaciu-Marcov, S. D. (2010). Feeding of three syntopic newt species (*Triturus cristatus*, *Mesotriton alpestris* and *Lissotriton vulgaris*) from Western Romania.
- Culler, L. E., & Lamp, W. O. (2009). Selective predation by larval *Agabus* (Coleoptera: *Dytiscidae*) on mosquitoes: support for conservation-based mosquito suppression in constructed wetlands. *Freshwater Biology*, 54(9), 2003–2014. <https://doi.org/10.1111/j.1365-2427.2009.02230.x>
- Dadd, R. H. (1975). Ingestion of colloid solutions by filter-feeding mosquito larvae: Relationship to viscosity. *Journal of Experimental Zoology*, 191(3), 395–406. <https://doi.org/10.1002/jez.1401910310>
- Dahl, E. (1956). Ecological Salinity Boundaries in Poikilohaline Waters. *Oikos*, 7(1), 1. <https://doi.org/10.2307/3564981>
- Dale, P. E. R., & Knight, J. M. (2012). Managing mosquitoes without destroying wetlands: An eastern Australian approach. *Wetlands Ecology and Management*, 20(3), 233–242. <https://doi.org/10.1007/s11273-012-9262-6>
- Dasrat, C. M., & Maharaj, G. (2021). Biological control of mosquitoes with odonates: A case study in Guyana. *NU S A NTA RA B IOSC IE NC E*, 7. <https://doi.org/10.13057/nusbiosci/n130205>
- David, J.-P., Rey, D., Meyran, J.-C., & Marigo, G. (2001). Involvement of Ligninlike Compounds in Toxicity of Dietary Alder Leaf Litter Against Mosquito Larvae. 27(1), 14. <https://doi.org/10.1023/A:1005632403561>
- David, J.-P., Rey, D., Pautou, M.-P., & Meyran, J.-C. (2000). Differential Toxicity of Leaf Litter to Dipteran Larvae of Mosquito Developmental Sites. *Journal of Invertebrate Pathology*, 75(1), 9–18. <https://doi.org/10.1006/jjpa.1999.4886>
- Day, J. (2016). Mosquito Oviposition Behavior and Vector Control. *Insects*, 7(4), 65. <https://doi.org/10.3390/insects7040065>
- De Brito Arduino, M., Mucci, L. F., Serpa, L. L. N., & De Moura Rodrigues, M. (2015). Effect of salinity on the behavior of *Aedes aegypti* populations from the coast and plateau of southeastern Brazil. *Journal of Vector Borne Diseases*, 52(1), 79–87.

- de Garine-Wichatitsky, M., Lwande, O. W., Fountain-Jones, N. M., VanderWaal, K., & Obanda, V. (2022). Editorial: Disease Ecology: Novel Concepts and Methods to Track and Forecast Disease Emergence, Transmission, Spread, and Endemization. *Frontiers in Ecology and Evolution*, *10*. <https://doi.org/10.3389/fevo.2022.890510>
- de Louw, P. G. B., Vandenbohede, A., Werner, A. D., & Oude Essink, G. H. P. (2013). Natural saltwater upconing by preferential groundwater discharge through boils. *Journal of Hydrology*, *490*, 74–87. <https://doi.org/10.1016/j.jhydrol.2013.03.025>
- De Majo, M. S., Zanotti, G., Campos, R. E., & Fischer, S. (2019). Effects of Constant and Fluctuating Low Temperatures on the Development of *Aedes aegypti* (Diptera: Culicidae) from a Temperate Region. *Journal of Medical Entomology*, *56*(6), 1661–1668. <https://doi.org/10.1093/jme/tjz087>
- Dellar, M., Boerlijst, S. P., & Holmes, D. (2022). Improving estimations of life history parameters of small animals in mesocosm experiments: A case study on mosquitoes. *Methods in Ecology and Evolution*, 2041-210X.13814. <https://doi.org/10.1111/2041-210X.13814>
- Delsman, J., Oude Essink, G., Huizer, S., Bootsma, H., Mulder, T., Zitman, P., & Romero Verastegui, B. (2020). *Actualisatie zout in het NHI (11205261-003-BGS-0001)*. Deltares.
- Destoumieux-Garzón, D., Mavingui, P., Boetsch, G., Boissier, J., Darriet, F., Duboz, P., Fritsch, C., Giraudoux, P., Le Roux, F., Morand, S., Paillard, C., Pontier, D., Sueur, C., & Voituron, Y. (2018). The One Health Concept: 10 Years Old and a Long Road Ahead. *Frontiers in Veterinary Science*, *5*. <https://doi.org/10.3389/fvets.2018.00014>
- Dhileepan, K. (1997). Physical Factors and Chemical Cues in the Oviposition Behavior of Arboviral Vectors *Culex annulostris* and *Culex molestus* (Diptera: Culicidae). *Environmental Entomology*, *26*(2), 318–326. <https://doi.org/10.1093/ee/26.2.318>
- Di Cecco, G. J., & Hurlbert, A. H. (2022). Anthropogenic drivers of avian community turnover from local to regional scales. *Global Change Biology*, *28*(3), 770–781. <https://doi.org/10.1111/gcb.15967>
- Dinithi, D., & Hemantha, W. (2020). Co-occurrence of *Lutzia fuscana* and *Aedes albopictus* (Diptera:Culicidae) in Native Habitats: As an Implication for Biological Control. *Rajarata University Journal*, *5*(11). <http://repository.rjt.ac.lk/bitstream/handle/123456789/4566/Co-occurrence%20of%20Lutzia%20fuscana%20and%20Aedes%20albopictus.pdf?sequence=1>

## References

---

- Don, N. C., Hang, N. T. M., Araki, H., Yamanishi, H., & Koga, K. (2006). Salinization processes in an alluvial coastal lowland plain and effect of sea water level rise. *Environmental Geology*, 49(5), 743–751. <https://doi.org/10.1007/s00254-005-0119-7>
- Donini, A., Gaidhu, M. P., Strasberg, D. R., & O'Donnell, M. J. (2007). Changing salinity induces alterations in hemolymph ion concentrations and Na<sup>+</sup> and Cl<sup>-</sup> transport kinetics of the anal papillae in the larval mosquito, *Aedes aegypti*. *Journal of Experimental Biology*, 210(6), 983–992. <https://doi.org/10.1242/jeb.02732>
- Dunlop, J. E., Horrigan, N., McGregor, G., Kefford, B. J., Choy, S., & Prasad, R. (2008). Effect of spatial variation on salinity tolerance of macroinvertebrates in Eastern Australia and implications for ecosystem protection trigger values. *Environmental Pollution*, 151(3), 621–630. <https://doi.org/10.1016/j.envpol.2007.03.020>
- DuRant, S. E., & Hopkins, W. A. (2008). Amphibian predation on larval mosquitoes. *Canadian Journal of Zoology*, 86(10), 1159–1164. <https://doi.org/10.1139/Z08-097>
- Easterling, D. R., Horton, B., Jones, P. D., Peterson, T. C., Karl, T. R., Parker, D. E., Salinger, M. J., Razuvayev, V., Plummer, N., Jamason, P., & Folland, C. K. (1997). Maximum and Minimum Temperature Trends for the Globe. *Science*, 277(5324), 364–367. <https://doi.org/10.1126/science.277.5324.364>
- Edwards, K., Mcculloch, J., Peterkershaw, G., & Jefferies, R. (2006). Soil microbial and nutrient dynamics in a wet Arctic sedge meadow in late winter and early spring. *Soil Biology and Biochemistry*, 38(9), 2843–2851. <https://doi.org/10.1016/j.soilbio.2006.04.042>
- Eisenhauer, N., Ochoa-Hueso, R., Huang, Y., Barry, K. E., Gebler, A., Guerra, C. A., Hines, J., Jochum, M., Andrzejek, K., Bucher, S. F., Buscot, F., Ciobanu, M., Chen, H., Junker, R., Lange, M., Lehmann, A., Rillig, M., Römermann, C., Ulrich, J., ... Türke, M. (2023). Ecosystem consequences of invertebrate decline. *Current Biology*, S0960982223012289. <https://doi.org/10.1016/j.cub.2023.09.012>
- Eitam, A., & Blaustein, L. (2004). Oviposition habitat selection by mosquitoes in response to predator (*Notonecta maculata*) density. *Physiological Entomology*, 29(2), 188–191. <https://doi.org/10.1111/j.0307-6962.2004.0372.x>
- El Husseiny, I., Elbrense, H., Roeder, T., & El Kholy, S. (2018). Hormonal modulation of cannibalistic behaviors in mosquito (*Culex pipiens*) larvae. *Journal of Insect Physiology*, 109, 144–148. <https://doi.org/10.1016/j.jinsphys.2018.08.001>

- Elias, E., Savoy, H. M., Swanson, D. A., Cohnstaedt, L. W., Peters, D. P. C., Derner, J. D., Pelzel-McCluskey, A., Drolet, B., & Rodriguez, L. (2022). Landscape dynamics of a vector-borne disease in the western US: How vector–habitat relationships inform disease hotspots. *Ecosphere*, 13(11), e4267. <https://doi.org/10.1002/ecs2.4267>
- Ellwanger, J. H., Byrne, L. B., & Chies, J. A. B. (2022). Examining the paradox of urban disease ecology by linking the perspectives of Urban One Health and Ecology with Cities. *Urban Ecosystems*, 25(6), 1735–1744. <https://doi.org/10.1007/s11252-022-01260-5>
- El-Sheikh, E.-S. M. Y., Fouda, M. A., Hassan, M. I., Abd-Elghaphar, A.-E. A., & Hasaballah, A. I. (2010). Toxicological Effects of Some Heavy Metal Ions on *Culex pipiens* L. (Diptera: Culicidae). *Egyptian Academic Journal of Biological Sciences, F. Toxicology & Pest Control*, 2(1), 63–76. <https://doi.org/10.21608/eajbsf.2010.17465>
- Emidi, B., Kisinza, W. N., Mmbando, B. P., Malima, R., & Mosha, F. W. (2017). Effect of physicochemical parameters on *Anopheles* and *Culex* mosquito larvae abundance in different breeding sites in a rural setting of Muheza, Tanzania. *Parasites & Vectors*, 10(1), 304. <https://doi.org/10.1186/s13071-017-2238-x>
- Eremeeva, N. I., & Sushchev, D. V. (2005). Structural Changes in the Fauna of Pollinating Insects in Urban Landscapes. *Russian Journal of Ecology*, 36(4), 259–265. <https://doi.org/10.1007/s11184-005-0070-6>
- Erraguntla, M., Dave, D., Zapletal, J., Myles, K., Adelman, Z. N., Pohlenz, T. D., & Lawley, M. (2021). Predictive model for microclimatic temperature and its use in mosquito population modeling. *Scientific Reports*, 11(1), 18909. <https://doi.org/10.1038/s41598-021-98316-x>
- Ersoy, Z., Abril, M., Cañedo-Argüelles, M., Espinosa, C., Vendrell-Puigmitja, L., & Proia, L. (2022). Experimental assessment of salinization effects on freshwater zooplankton communities and their trophic interactions under eutrophic conditions. *Environmental Pollution*, 313, 120127. <https://doi.org/10.1016/j.envpol.2022.120127>
- Esser, H. J., Mögling, R., Cleton, N. B., van der Jeugd, H., Sprong, H., Stroo, A., Koopmans, M. P. G., de Boer, W. F., & Reusken, C. B. E. M. (2019). Risk factors associated with sustained circulation of six zoonotic arboviruses: A systematic review for selection of surveillance sites in non-endemic areas. *Parasites & Vectors*, 12(1), 265. <https://doi.org/10.1186/s13071-019-3515-7>

## References

---

- Ezeakacha, N. F., & Yee, D. A. (2019). The role of temperature in affecting carry-over effects and larval competition in the globally invasive mosquito *Aedes albopictus*. *Parasites & Vectors*, 12(1), 123. <https://doi.org/10.1186/s13071-019-3391-1>
- Faridah, L., Fauziah, N., Agustian, D., Mindra Jaya, I. G. N., Eka Putra, R., Ekawardhani, S., Hidayath, N., Damar Djati, I., Carvajal, T. M., Mayasari, W., Ruluwedrata Rinawan, F., & Watanabe, K. (2022). Temporal Correlation Between Urban Microclimate, Vector Mosquito Abundance, and Dengue Cases. *Journal of Medical Entomology*, 59(3), 1008–1018. <https://doi.org/10.1093/jme/tjac005>
- Ferraguti, M., Magallanes, S., Suarez-Rubio, M., Bates, P. J. J., Marzal, A., & Renner, S. C. (2023). Does land-use and land cover affect vector-borne diseases? A systematic review and meta-analysis. *Landscape Ecology*, 38(10), 2433–2451. <https://doi.org/10.1007/s10980-023-01746-3>
- Ferraguti, M., Martínez-de la Puente, J., Roiz, D., Ruiz, S., Soriguer, R., & Figuerola, J. (2016). Effects of landscape anthropization on mosquito community composition and abundance. *Scientific Reports*, 6(1), 29002. <https://doi.org/10.1038/srep29002>
- Figueroa, D. P., Scott, S., Gonzalez, C. R., Veloso, C., & Canals, M. (2016). Assessing the larval niche of *Culex pipiens* in Chile. *International Journal of Mosquito Research*, 3(4), 11–16.
- Fischer, S., Pereyra, D., & Fernández, L. (2012). Predation ability and non-consumptive effects of *Notonecta sellata* (Heteroptera: *Notonectidae*) on immature stages of *Culex pipiens* (Diptera: *Culicidae*). *Journal of Vector Ecology*, 37(1), 245–251. <https://doi.org/10.1111/j.1948-7134.2012.00223.x>
- Floore, T. G. (2006). Mosquito larval control practices: Past and present. *Journal of the American Mosquito Control Association*, 22(3), 527–533. [https://doi.org/10.2987/8756-971X\(2006\)22\[527:MLCPPA\]2.0.CO;2](https://doi.org/10.2987/8756-971X(2006)22[527:MLCPPA]2.0.CO;2)
- Foley, J. A., DeFries, R., Asner, G. P., Barford, C., Bonan, G., Carpenter, S. R., Chapin, F. S., Coe, M. T., Daily, G. C., Gibbs, H. K., Helkowski, J. H., Holloway, T., Howard, E. A., Kucharik, C. J., Monfreda, C., Patz, J. A., Prentice, I. C., Ramankutty, N., & Snyder, P. K. (2005). Global Consequences of Land Use. *Science*, 309(5734), 570–574. <https://doi.org/10.1126/science.1111772>
- Folly, A. J., Waller, E. S. L., McCracken, F., McElhinney, L. M., Roberts, H., & Johnson, N. (2020). Equine seroprevalence of West Nile virus antibodies in the UK in 2019. *Parasites & Vectors*, 13(1), 596. <https://doi.org/10.1186/s13071-020-04481-9>

- Franklinos, L. H. V., Jones, K. E., Redding, D. W., & Abubakar, I. (2019). The effect of global change on mosquito-borne disease. *The Lancet Infectious Diseases*, 19(9), e302–e312. [https://doi.org/10.1016/S1473-3099\(19\)30161-6](https://doi.org/10.1016/S1473-3099(19)30161-6)
- Geest, G. J., Arts, G. H. P., & van Dijk, G. (2022). *Systeemkennis brakke wateren (2022–39; Brakke wateren)*. Wageningen University. <https://edepot.wur.nl/574933>
- Geetha, I., & Manonmani, A. M. (2008). Mosquito pupicidal toxin production by *Bacillus subtilis* subsp. *Subtilis*. *Biological Control*, 44(2), 242–247. <https://doi.org/10.1016/j.biocontrol.2007.10.007>
- Global Burden of Disease Pediatrics Collaboration. (2016). *Top 25 Global Causes of Disability-Adjusted Life-Years (DALYs) in Children Younger Than 5 Years, Both Sexes, 1990 and 2013*. <https://doi.org/10.1001/jamapediatrics.2015.4276>
- Golovatyuk, L. V., & Shitikov, V. K. (2016). Salinity tolerance of macrozoobenthic taxa in small rivers of the Lake Elton basin. *Russian Journal of Ecology*, 47(6), 540–545. <https://doi.org/10.1134/S1067413616060059>
- Gosner, K. L. (1960). A Simplified Table for Staging Anuran Embryos and Larvae with Notes on Identification. *Herpetologica*, 16(3), 183–190. <http://www.jstor.org/stable/3890061>
- Gottwalt, A. (2013). Impacts of Deforestation on Vector-borne Disease Incidence. *The Columbia University Journal of Global Health*, 3(2), Article 2. <https://doi.org/10.7916/thejgh.v3i2.4864>
- Gracey, A. Y., Fraser, E. J., Li, W., Fang, Y., Taylor, R. R., Rogers, J., Brass, A., & Cossins, A. R. (2004). Coping with cold: An integrative, multitissue analysis of the transcriptome of a poikilothermic vertebrate. *Proceedings of the National Academy of Sciences*, 101(48), 16970–16975. <https://doi.org/10.1073/pnas.0403627101>
- Gratz, N. G. (1999). Emerging and resurging vector-borne diseases. *Annual Review of Entomology*, 44(Volume 44, 1999), 51–75. <https://doi.org/10.1146/annurev.ento.44.1.51>
- Green, M. H. (2018). Climate and Disease in Medieval Eurasia. In *Oxford Research Encyclopedia of Asian History*. <https://doi.org/10.1093/acrefore/9780190277727.013.6>
- Greenhalgh, M., & Oviden, D. (2007). *Freshwater Life*.

## References

---

- Greenspan, S. E., Morris, W., Warburton, R., Edwards, L., Duffy, R., Pike, D. A., Schwarzkopf, L., & Alford, R. A. (2016). Low-cost fluctuating-temperature chamber for experimental ecology. *Methods in Ecology and Evolution*, 7(12), 1567–1574. <https://doi.org/10.1111/2041-210X.12619>
- Guo, X., Li, C., Deng, Y., Xing, D., Liu, Q., Wu, Q., Sun, A., Dong, Y., Cao, W., Qin, C., & Zhao, T. (2016). *Culex pipiens quinquefasciatus*: A potential vector to transmit Zika virus. *Emerging Microbes & Infections*, 5(1), 1–5. <https://doi.org/10.1038/emi.2016.102>
- Gutiérrez-López, R., Martínez-de la Puente, J., Gangoso, L., Yan, J., Soriguer, R. C., & Figuerola, J. (2016). Do mosquitoes transmit the avian malaria-like parasite *Haemoproteus*? An experimental test of vector competence using mosquito saliva. *Parasites & Vectors*, 9(1), 609. <https://doi.org/10.1186/s13071-016-1903-9>
- Hagstrum, D. W., & Hagstrum, W. R. (1970). A Simple Device for Producing Fluctuating Temperatures, with an Evaluation of the Ecological Significance of Fluctuating Temperatures<sup>1</sup>. *Annals of the Entomological Society of America*, 63(5), 1385–1389. <https://doi.org/10.1093/aesa/63.5.1385>
- Hagstrum, D. W., & Milliken, G. A. (1991). Modeling Differences in Insect Developmental times between Constant and Fluctuating Temperatures. *Annals of the Entomological Society of America*, 84(4), 369–379. <https://doi.org/10.1093/aesa/84.4.369>
- Hall, J. M., & Warner, D. A. (2020). Ecologically relevant thermal fluctuations enhance offspring fitness: Biological and methodological implications for studies of thermal developmental plasticity. *Journal of Experimental Biology*, 223(19), jeb231902. <https://doi.org/10.1242/jeb.231902>
- Hallmann, C. A., Sorg, M., Jongejans, E., Siepel, H., Hofland, N., Schwan, H., Stenmans, W., Müller, A., Sumser, H., Hörren, T., Goulson, D., & de Kroon, H. (2017). More than 75 percent decline over 27 years in total flying insect biomass in protected areas. *PLOS ONE*, 12(10), e0185809. <https://doi.org/10.1371/journal.pone.0185809>
- Hamaidia, K., & Soltani, N. (2016). Ovicidal activity of an insect growth disruptor (methoxyfenozide) against *Culex pipiens* L. and delayed effect on development. *Journal of Entomology and Zoology Studies*, 4(4), 6. <http://www.univ-soukahras.dz/eprints/2016-837-6f442.pdf>

- Hamdan, H., Sofian-Azirun, M., Ahmad, N. W., & Lim, L. H. (2005). Insecticide resistance development in *Culex quinquefasciatus* (Say), *Aedes aegypti* (L.) and *Aedes albopictus* (Skuse) larvae against malathion, permethrin and temephos. 22(1), 45–52. [https://www.academia.edu/download/30404446/Insecticide\\_resistance\\_development\\_in\\_Culex\\_quinquefasciatus\\_\(Say\)\\_\\_Aedes\\_aegypti\\_\(L.\)\\_and\\_Aedes\\_albopictus\\_\(Skuse\)\\_larvae\\_against\\_malat.pdf](https://www.academia.edu/download/30404446/Insecticide_resistance_development_in_Culex_quinquefasciatus_(Say)__Aedes_aegypti_(L.)_and_Aedes_albopictus_(Skuse)_larvae_against_malat.pdf)
- Harbach, R. E. (2012). *Culex pipiens*: Species Versus Species Complex – Taxonomic History and Perspective. *Journal of the American Mosquito Control Association*, 28(4), 10–23. <https://doi.org/10.2987/8756-971X-28.4.10>
- Harvey, J. A., Malcicka, M., & Ellers, J. (2015). Integrating more biological and ecological realism into studies of multitrophic interactions. *Ecological Entomology*, 40(4), 349–352. <https://doi.org/10.1111/een.12204>
- Hasselschwert, D., & Rockett, C. L. (1988). Bacteria as Ovipositional Attractants for *Aedes Aegypti* (Diptera: Culicidae). 21(4), 7.
- Headlee, T. J. (1941). Further Studies of the Relative Effects on Insect Metabolism of Temperatures Derived from Constant and Variable Sources. *Journal of Economic Entomology*, 34(2), 171–174. <https://doi.org/10.1093/jee/34.2.171>
- Hermann, M., Jansen, R., van de Glind, J., Peeters, E. T. H. M., & Van den Brink, P. J. (2022). A transportable temperature and heatwave control device (TENTACLE) for laboratory and field simulations of different climate change scenarios in aquatic micro- and mesocosms. *HardwareX*, 11, e00307. <https://doi.org/10.1016/j.ohx.2022.e00307>
- Hilderink, H. B. M., Plasmans, M. H. D., Poos, M. J. J. C. (René), Eysink, P. E. D., & Gijzen, R. (2020). Dutch DALYs, current and future burden of disease in the Netherlands. *Archives of Public Health*, 78(1), 85. <https://doi.org/10.1186/s13690-020-00461-8>
- Hubálek, Z. (2008). Mosquito-borne viruses in Europe. *Parasitology Research*, 103(S1), Article S1. <https://doi.org/10.1007/s00436-008-1064-7>
- Hudson, B. N. A. (1956). The Behaviour of the Female Mosquito in Selecting Water for Oviposition. *Journal of Experimental Biology*, 33(3), 478–492. <https://doi.org/10.1242/jeb.33.3.478>

## References

---

- Huffaker, C. B. (1944). The Temperature Relations Of The Immature Stages Of The Malarial Mosquito, *Anopheles Quadrimaculatus* Say, With A Comparison Of The Developmental Power Of Constant And Variable Temperatures In Insect Metabolism<sup>1,2</sup>. *Annals of the Entomological Society of America*, 37(1), 1–27. <https://doi.org/10.1093/aesa/37.1.1>
- Huxley, P. J., Murray, K. A., Pawar, S., & Cator, L. J. (2021). The effect of resource limitation on the temperature dependence of mosquito population fitness. <https://doi.org/10.1098/rspb.2020.3217>
- Ibanez-Justicia, A., Stroo, A., Dik, M., Beeuwkes, J., & Scholte, E. J. (2015). National Mosquito (Diptera: *Culicidae*) Survey in The Netherlands 2010-2013. *Journal of Medical Entomology*, 52(2), 185–198. <https://doi.org/10.1093/jme/tju058>
- Ikeshoji, T. (1966). Attractant and Stimulant Factors for Oviposition of *Culex pipiens fatigans* in Natural Breeding-Sites. *Bulletin of the World Health Organization*, 35(6), 905–912. <https://www.ncbi.nlm.nih.gov/pmc/articles/PMC2476291/>
- Ikeshoji, T., & Mulla, M. S. (1970). Oviposition Attractants for Four Species of Mosquitoes in Natural Breeding Waters. *Annals of the Entomological Society of America*, 63(5), 1322–1327. <https://doi.org/10.1093/aesa/63.5.1322>
- Impoinvil, D. E., Cardenas, G. A., Gihure, J. I., Mbogo, C. M., & Beier, J. C. (2007). Constant temperature and time period effects on *Anopheles gambiae* egg hatching. *Journal of the American Mosquito Control Association*, 23(2), 124–130. [https://doi.org/10.2987/8756-971X\(2007\)23\[124:CTATPE\]2.0.CO;2](https://doi.org/10.2987/8756-971X(2007)23[124:CTATPE]2.0.CO;2)
- Jennings, S., Warr, K. J., & Mackinson, S. (2002). Use of size-based production and stable isotope analyses to predict trophic transfer efficiencies and predator-prey body mass ratios in food webs. *Marine Ecology Progress Series*, 240, 11–20. <https://doi.org/10.3354/meps240011>
- Johansson, F., Lederer, B., & Lind, M. I. (2010). Trait Performance Correlations across Life Stages under Environmental Stress Conditions in the Common Frog, *Rana temporaria*. *PLOS ONE*, 5(7), e11680. <https://doi.org/10.1371/journal.pone.0011680>
- Jourdan, J., Baier, J., Riesch, R., Klimpel, S., Streit, B., Müller, R., & Plath, M. (2016). Adaptive growth reduction in response to fish kairomones allows mosquito larvae (*Culex pipiens*) to reduce predation risk. *Aquatic Sciences*, 78(2), 303–314. <https://doi.org/10.1007/s00027-015-0432-5>

- Jude, P. J., Tharmasegaram, T., Sivasubramaniyam, G., Senthilnathanan, M., Kannathasan, S., Raveendran, S., Ramasamy, R., & Surendran, S. N. (2012). Salinity-tolerant larvae of mosquito vectors in the tropical coast of Jaffna, Sri Lanka and the effect of salinity on the toxicity of *Bacillus thuringiensis* to *Aedes aegypti* larvae. *Parasites & Vectors*, 5(1), 269. <https://doi.org/10.1186/1756-3305-5-269>
- Juliano, S. A. (2007). Population Dynamics. *Journal of the American Mosquito Control Association*, 23(2 Suppl), 265–275.
- Kamdem, C., Tene Fossog, B., Simard, F., Etouana, J., Ndo, C., Kengne, P., Boussès, P., Etoa, F.-X., Awono-Ambene, P., Fontenille, D., Antonio-Nkondjio, C., Besansky, N. J., & Costantini, C. (2012). Anthropogenic Habitat Disturbance and Ecological Divergence between Incipient Species of the Malaria Mosquito *Anopheles gambiae*. *PLoS ONE*, 7(6), e39453. <https://doi.org/10.1371/journal.pone.0039453>
- Kauffman, E., Payne, A., Franke, M., Schmid, M., Harris, E., & Kramer, L. (2017). Rearing of *Culex spp.* And *Aedes spp.* Mosquitoes. *BIO-PROTOCOL*, 7(17). <https://doi.org/10.21769/BioProtoc.2542>
- Kazlauskienė, R., Bernotienė, R., Palinauskas, V., Iezhova, T. A., & Valkiūnas, G. (2013). *Plasmodium relictum* (lineages pSGS1 and pGRW11): Complete synchronous sporogony in mosquitoes *Culex pipiens pipiens*. *Experimental Parasitology*, 133(4), 454–461. <https://doi.org/10.1016/j.exppara.2013.01.008>
- Kehoe, R., Frago, E., & Sanders, D. (2021). Cascading extinctions as a hidden driver of insect decline. *Ecological Entomology*, 46(4), 743–756. <https://doi.org/10.1111/een.12985>
- Kenawy, M. A., Ammar, S. E., & Abdel-Rahman, H. A. (2013). Physico-chemical characteristics of the mosquito breeding water in two urban areas of Cairo Governorate, Egypt. *Journal of Entomological and Acarological Research*, 45(3), 17. <https://doi.org/10.4081/jear.2013.e17>
- Kengne, P., Charmantier, G., Blondeau-Bidet, E., Costantini, C., & Ayala, D. (2019). Tolerance of disease-vector mosquitoes to brackish water and their osmoregulatory ability. *Ecosphere*, 10(10). <https://doi.org/10.1002/ecs2.2783>
- Kennedy, J. S. (1942). On Water-finding and Oviposition by captive Mosquitoes. *Bulletin of Entomological Research*, 32(4), 279–301. <https://doi.org/10.1017/S0007485300017235>

## References

---

- Kern, P., Cramp, R. L., & Franklin, C. E. (2015). Physiological responses of ectotherms to daily temperature variation. *Journal of Experimental Biology*, 218(19), 3068–3076. <https://doi.org/10.1242/jeb.123166>
- Khan, A. E., Ireson, A., Kovats, S., Mojumder, S. K., Khusru, A., Rahman, A., & Vineis, P. (2011). Drinking Water Salinity and Maternal Health in Coastal Bangladesh: Implications of Climate Change. *Environmental Health Perspectives*, 119(9), 1328–1332. <https://doi.org/10.1289/ehp.1002804>
- Kiarie-Makara, M. W., Ngumbi, P. M., & Lee, D.-K. (2015). Effects of Temperature on the Growth and Development of *Culex pipiens* Complex Mosquitoes (Diptera: Culicidae). *Journal of Pharmacy and Biological Sciences*, 10(6), 1–10.
- Kingsolver, J. G., Higgins, J. K., & Augustine, K. E. (2015). Fluctuating temperatures and ectotherm growth: Distinguishing non-linear and time-dependent effects. *Journal of Experimental Biology*, 218(14), 2218–2225. <https://doi.org/10.1242/jeb.120733>
- Knight, T. M., Chase, J. M., Goss, C. W., & Knight, J. J. (2004). Effects of interspecific competition, predation, and their interaction on survival and development time of immature *Anopheles quadrimaculatus*. *Journal of Vector Ecology*, 29(2), 277–284.
- Ko, K. Y., & Eiel, E. L. (1986). Asymmetric synthesis of (5R,6S)-6-acetoxy-5-hexadecanolide, the major component of the oviposition attractant pheromone of the mosquito *Culex pipiens fatigans*, and two of its stereoisomers. *The Journal of Organic Chemistry*, 51(26), 5353–5362. <https://doi.org/10.1021/jo00376a056>
- Koenraadt, C. J. M., & Harrington, L. C. (2008). Flushing Effect of Rain on Container-Inhabiting Mosquitoes *Aedes aegypti* and *Culex pipiens* (Diptera: Culicidae). *JOURNAL OF MEDICAL ENTOMOLOGY*, 45(1).
- Koenraadt, C. J. M., & Takken, W. (2003). Cannibalism and predation among larvae of the *Anopheles gambiae* complex. *Medical and Veterinary Entomology*, 17(1), 61–66. <https://doi.org/10.1046/j.1365-2915.2003.00409.x>
- Kolimenakis, A., Heinz, S., Wilson, M. L., Winkler, V., Yakob, L., Michaelakis, A., Papachristos, D., Richardson, C., & Horstick, O. (2021). The role of urbanisation in the spread of *Aedes* mosquitoes and the diseases they transmit—A systematic review. *PLOS Neglected Tropical Diseases*, 15(9), e0009631. <https://doi.org/10.1371/journal.pntd.0009631>
- Kovács, T., Anthony, B. P., Kondorosy, E., & Török, J. (2014). Predation on heteropterans within an assemblage of anurans at Kis-Balaton, Hungary. *North-Western Journal of Zoology*, 10(2), 236–244.

- Kraemer, M. U. G., Sinka, M. E., Duda, K. A., Mylne, A. Q. N., Shearer, F. M., Barker, C. M., Moore, C. G., Carvalho, R. G., Coelho, G. E., Van Bortel, W., Hendrickx, G., Schaffner, F., Elyazar, I. R. F., Teng, H.-J., Brady, O. J., Messina, J. P., Pigott, D. M., Scott, T. W., Smith, D. L., ... Hay, S. I. (2015). The global distribution of the arbovirus vectors *Aedes aegypti* and *Ae. Albopictus*. *eLife*, 4, e08347. <https://doi.org/10.7554/eLife.08347>
- Kroeger, I., Liess, M., Dziöck, F., & Duquesne, S. (2013). Sustainable control of mosquito larvae in the field by the combined actions of the biological insecticide Bti and natural competitors. *Journal of Vector Ecology*, 38(1), 82–89. <https://doi.org/10.1111/j.1948-7134.2013.12012.x>
- Krol, L., Blom, R., Dellar, M., Van Der Beek, J. G., Stroo, A. C. J., Van Bodegom, P. M., Geerling, G. W., Koenraadt, C. J. M., & Schrama, M. (2023). Interactive effects of climate, land use and soil type on *Culex pipiens/torrentium* abundance. *One Health*, 17, 100589. <https://doi.org/10.1016/j.onehlt.2023.100589>
- Krol, L., Gorsich, E. E., Hunting, E. R., Govender, D., van Bodegom, P. M., & Schrama, M. (2019). Eutrophication governs predator-prey interactions and temperature effects in *Aedes aegypti* populations. *Parasites & Vectors*, 12(1), 179. <https://doi.org/10.1186/s13071-019-3431-x>
- Kumar, R., & Hwang, J.-S. (2006). Larvicidal Efficiency of Aquatic Predators: A Perspective for Mosquito Biocontrol. *Zoological Studies*.
- Kuznetsov, V. A., Zdanovich, V. V., Lobachov, E. A., & Lukiyarov, S. V. (2016). Revisiting the problem of astatic ecological optima. *Biology Bulletin Reviews*, 6(2), 164–176. <https://doi.org/10.1134/S2079086416020043>
- Lacey, L. A., & Orr, B. K. (1994). The Role of Biological Control of Mosquitoes in Integrated Vector Control. *The American Journal of Tropical Medicine and Hygiene*, 50(6\_Suppl), 97–115. <https://doi.org/10.4269/ajtmh.1994.50.97>
- Lambin, E. F., & Meyfroidt, P. (2011). Global land use change, economic globalization, and the looming land scarcity. *Proceedings of the National Academy of Sciences*, 108(9), 3465–3472. <https://doi.org/10.1073/pnas.1100480108>
- Lambin, E. F., Tran, A., Vanwambeke, S. O., Linard, C., & Soti, V. (2010). Pathogenic landscapes: Interactions between land, people, disease vectors, and their animal hosts. *International Journal of Health Geographics*, 9(1), 54. <https://doi.org/10.1186/1476-072X-9-54>

## References

---

- Lambin, E. F., Turner, B. L., Geist, H. J., Agbola, S. B., Angelsen, A., Folke, C., Bruce, J. W., Coomes, O. T., Dirzo, R., George, P. S., Homewood, K., Imbernon, J., Leemans, R., Li, X., Moran, E. F., Mortimore, M., Ramakrishnan, P. S., Richards, J. F., Steffen, W., ... Veldkamp, T. A. (2001). *The causes of land-use and land-cover change: Moving beyond the myths*. 11, 261–269.
- Laporta, G. Z., & Sallum, M. A. M. (2014). Coexistence mechanisms at multiple scales in mosquito assemblages. *BMC Ecology*, 14(1), 30. <https://doi.org/10.1186/s12898-014-0030-8>
- Lassiter, A. (2021). Rising seas, changing salt lines, and drinking water salinization. *Current Opinion in Environmental Sustainability*, 50, 208–214. <https://doi.org/10.1016/j.cosust.2021.04.009>
- Lawler, S. P. (2017). Environmental safety review of methoprene and bacterially-derived pesticides commonly used for sustained mosquito control. *Ecotoxicology and Environmental Safety*, 139, 335–343. <https://doi.org/10.1016/j.ecoenv.2016.12.038>
- Laydon, D. J., Cauchemez, S., Hinsley, W. R., Bhatt, S., & Ferguson, N. M. (2023). Impact of proactive and reactive vaccination strategies for health-care workers against MERS-CoV: A mathematical modelling study. *The Lancet Global Health*, 11(5), e759–e769. [https://doi.org/10.1016/S2214-109X\(23\)00117-1](https://doi.org/10.1016/S2214-109X(23)00117-1)
- Leishnam, P. T., Slaney, D. P., Lester, P. J., Weinstein, P., & Heath, A. C. G. (2007). Mosquito density, macroinvertebrate diversity, and water chemistry in water-filled containers: Relationships to land use. *New Zealand Journal of Zoology*, 34(3), 203–218. <https://doi.org/10.1080/03014220709510079>
- Li, J., Deng, T., Li, H., Chen, L., & Mo, J. (2009). Effects of Water Color and Chemical Compounds on the Oviposition Behavior of Gravid *Culex pipiens pallens* Females under Laboratory Conditions. *Journal of Agricultural and Urban Entomology*, 26(1), 23–30. <https://doi.org/10.3954/1523-5475-26.1.23>
- Li, X., Ma, L., Sun, L., & Zhu, C. (2002). Biotic characteristics in the deltamethrin-susceptible and resistant strains of *Culex pipiens pallens* (Diptera: Culicidae) in China. *Applied Entomology and Zoology*, 37(2), 305–308. <https://doi.org/10.1303/aez.2002.305>
- Lines, J., Harpham, T., Leake, C., & Schofield, C. (1994). Trends, priorities and policy directions in the control of vector-borne diseases in urban environments. *Health Policy and Planning*, 9(2), 113–129. <https://doi.org/10.1093/heapol/9.2.113>

- Little, S. E. (2013). Future challenges for parasitology: Vector control and one health in the Americas. *Veterinary Parasitology*, 195(3), 249–255. <https://doi.org/10.1016/j.vetpar.2013.04.006>
- Loeb, R., & Verdonschot, P. F. M. (2008). *Complexiteit van nutriëntenlimitaties in oppervlaktewateren* (128; , WOt-werkdocume, p. 68). Wageningen, Wettelijke Onderzoekstaken Natuur & Milie. <https://edepot.wur.nl/5464>
- Loetti, V., Schweigmann, N., & Burrioni, N. (2011). Development rates, larval survivorship and wing length of *Culex pipiens* (Diptera: Culicidae) at constant temperatures. *Journal of Natural History*, 45(35), 2203–2213. <https://doi.org/10.1080/00222933.2011.590946>
- Lohrer, A. M., & Wetz, J. J. (2003). Dredging-induced nutrient release from sediments to the water column in a southeastern saltmarsh tidal creek. *Marine Pollution Bulletin*, 46(9), 1156–1163. [https://doi.org/10.1016/S0025-326X\(03\)00167-X](https://doi.org/10.1016/S0025-326X(03)00167-X)
- Ludwig, D., & Cable, R. M. (1933). The Effect of Alternating Temperatures on the Pupal Development of *Drosophila melanogaster* Meigen. *Physiological Zoology*, 6(4), 493–508. <https://doi.org/10.1086/physzool.6.4.30151203>
- Lühken, R., Brattig, N., & Becker, N. (2023). Introduction of invasive mosquito species into Europe and prospects for arbovirus transmission and vector control in an era of globalization. *Infectious Diseases of Poverty*, 12(1), 109. <https://doi.org/10.1186/s40249-023-01167-z>
- Lundkvist, E., Landin, J., Jackson, M., & Svensson, C. (2003). Diving beetles (Dytiscidae) as predators of mosquito larvae (Culicidae) in field experiments and in laboratory tests of prey preference. *Bulletin of Entomological Research*, 93(3), 219–226. <https://doi.org/10.1079/BER2003237>
- Martin, A. P., & Palumbi, S. R. (1993). Body size, metabolic rate, generation time, and the molecular clock. *Proceedings of the National Academy of Sciences*, 90(9), 4087–4091. <https://doi.org/10.1073/pnas.90.9.4087>
- Maurer, B. A. (1999). The solution to ecological complexity? Untangling Ecological Complexity: The Macroscopic Perspective. *Trends in Ecology & Evolution*, 14(8), 331–332. [https://doi.org/10.1016/S0169-5347\(99\)01671-7](https://doi.org/10.1016/S0169-5347(99)01671-7)
- McDonald, G., & Buchanan, G. A. (1981). The mosquito and predatory insect fauna inhabiting fresh-water ponds, with particular reference to *Culex annulirostris* Skuse (Diptera: Culicidae). *Australian Journal of Ecology*, 6(1), 21–27. <https://doi.org/10.1111/j.1442-9993.1981.tb01270.x>

## References

---

- Meadows, A. J., Owen, J. P., & Snyder, W. E. (2017). Keystone nonconsumptive effects within a diverse predator community. *Ecology and Evolution*, 7(23), 10315–10325. <https://doi.org/10.1002/ece3.3392>
- Meckawy, R., Stuckler, D., Mehta, A., Al-Ahdal, T., & Doebbeling, B. N. (2022). Effectiveness of early warning systems in the detection of infectious diseases outbreaks: A systematic review. *BMC Public Health*, 22(1), 2216. <https://doi.org/10.1186/s12889-022-14625-4>
- Medeiros-Sousa, A. R., Fernandes, A., Ceretti-Junior, W., Wilke, A. B. B., & Marrelli, M. T. (2017). Mosquitoes in urban green spaces: Using an island biogeographic approach to identify drivers of species richness and composition. *Scientific Reports*, 7(1), 17826. <https://doi.org/10.1038/s41598-017-18208-x>
- Medlock, J. M., Hansford, K. M., Schaffner, F., Versteirt, V., Hendrickx, G., Zeller, H., & Bortel, W. V. (2012). A Review of the Invasive Mosquitoes in Europe: Ecology, Public Health Risks, and Control Options. *Vector-Borne and Zoonotic Diseases*, 12(6), 435–447. <https://doi.org/10.1089/vbz.2011.0814>
- Mellanby, K., & Gardiner, J. S. (1997). Low temperature and insect activity. *Proceedings of the Royal Society of London. Series B - Biological Sciences*, 127(849), 473–487. <https://doi.org/10.1098/rspb.1939.0035>
- Merritt, R. W., Dadd, R. H., & Walker, E. D. (1992). Feeding Behavior, Natural Food, and Nutritional Relationships of Larval Mosquitoes. *Annual Review of Entomology*, 37(1), 349–374. <https://doi.org/10.1146/annurev.en.37.010192.002025>
- Messina, J. P., Brady, O. J., Golding, N., Kraemer, M. U. G., Wint, G. R. W., Ray, S. E., Pigott, D. M., Shearer, F. M., Johnson, K., Earl, L., Marczak, L. B., Shirude, S., Davis Weaver, N., Gilbert, M., Velayudhan, R., Jones, P., Jaenisch, T., Scott, T. W., Reiner, R. C., & Hay, S. I. (2019). The current and future global distribution and population at risk of dengue. *Nature Microbiology*, 4(9), 1508–1515. <https://doi.org/10.1038/s41564-019-0476-8>
- Meyabeme Elono, A. L., Foit, K., Duquesne, S., & Liess, M. (2018). Controlling *Culex pipiens*: Antagonists are more efficient than a neonicotinoid insecticide. *Journal of Vector Ecology*, 43(1), 26–35. <https://doi.org/10.1111/jvec.12279>
- Michaelakis, A., Mihou, A. P., Couladouros, E. A., Zounos, A. K., & Koliopoulos, G. (2005). Oviposition Responses of *Culex pipiens* to a Synthetic Racemic *Culex quinquefasciatus* Oviposition Aggregation Pheromone. *Journal of Agricultural and Food Chemistry*, 53(13), 5225–5229. <https://doi.org/10.1021/jf0504871>

- Modoni, G., Darini, G., Spacagna, R. L., Saroli, M., Russo, G., & Croce, P. (2013). Spatial analysis of land subsidence induced by groundwater withdrawal. *Engineering Geology*, *167*, 59–71. <https://doi.org/10.1016/j.enggeo.2013.10.014>
- Montgomery, B. L., Shivas, M. A., Hall-Mendelin, S., Edwards, J., Hamilton, N. A., Jansen, C. C., McMahon, J. L., Warrilow, D., & van den Hurk, A. F. (2017). Rapid Surveillance for Vector Presence (RSVP): Development of a novel system for detecting *Aedes aegypti* and *Aedes albopictus*. *PLOS Neglected Tropical Diseases*, *11*(3), 1–15. <https://doi.org/10.1371/journal.pntd.0005505>
- Mottram, P., Kay, B. H., & Fanning, I. D. (1994). Development and Survival of *Culex sitiens* Wiedemann (Diptera: *Culicidae*) in Relation to Temperature and Salinity. *Australian Journal of Entomology*, *33*(1), 81–85. <https://doi.org/10.1111/j.1440-6055.1994.tb00926.x>
- Moura, J. A. S., & Souza-Santos, L. P. (2020). Environmental risk assessment (ERA) of pyriproxyfen in non-target aquatic organisms. *Aquatic Toxicology*, *222*, 105448. <https://doi.org/10.1016/j.aquatox.2020.105448>
- Multini, L. C., Oliveira-Christe, R., Medeiros-Sousa, A. R., Evangelista, E., Barrio-Nuevo, K. M., Mucci, L. F., Ceretti-Junior, W., Camargo, A. A., Wilke, A. B. B., & Marrelli, M. T. (2021). The Influence of the pH and Salinity of Water in Breeding Sites on the Occurrence and Community Composition of Immature Mosquitoes in the Green Belt of the City of São Paulo, Brazil. *Insects*, *12*(9), Article 9. <https://doi.org/10.3390/insects12090797>
- Murrell, E. G., & Juliano, S. A. (2008). Detritus Type Alters the Outcome of Interspecific Competition Between *Aedes aegypti* and *Aedes albopictus* (Diptera: *Culicidae*). *Journal of Medical Entomology*, *45*(3), 375–383. <https://doi.org/10.1093/jmedent/45.3.375>
- Muturi, E. J., Costanzo, K., Kesavaraju, B., Lampman, R., & Alto, B. W. (2010). Interaction of a pesticide and larval competition on life history traits of *Culex pipiens*. *Acta Tropica*, *116*(2), 141–146. <https://doi.org/10.1016/j.actatropica.2010.07.003>
- Muturi, E. J., Lampman, R., Costanzo, K., & Alto, B. W. (2011). Effect of Temperature and Insecticide Stress on Life-History Traits of *Culex restuans* and *Aedes albopictus* (Diptera: *Culicidae*). *Journal of Medical Entomology*, *48*(2), 243–250. <https://doi.org/10.1603/ME10017>

## References

---

- Muturi, E. J., Mwangangi, J., Shililu, J., Jacob, B. G., Mbogo, C., Githure, J., & Novak, R. J. (2008). Environmental factors associated with the distribution of *Anopheles arabiensis* and *Culex quinquefasciatus* in a rice agro-ecosystem in Mwea, Kenya. *Journal of Vector Ecology*, 33(1), 56–63. [https://doi.org/10.3376/1081-1710\(2008\)33\[56:EFAWTD\]2.0.CO;2](https://doi.org/10.3376/1081-1710(2008)33[56:EFAWTD]2.0.CO;2)
- Mwingira, V. S., Spitzen, J., Mboera, L. E. G., Torres-Estrada, J. L., & Takken, W. (2020). The Influence of Larval Stage and Density on Oviposition Site-Selection Behavior of the Afrotropical Malaria Mosquito *Anopheles coluzzii* (Diptera: Culicidae). *Journal of Medical Entomology*, 57(3), 657–666. <https://doi.org/10.1093/jme/tjz172>
- Myers, S. S. (2017). Planetary health: Protecting human health on a rapidly changing planet. *The Lancet*, 390(10114), 2860–2868. [https://doi.org/10.1016/S0140-6736\(17\)32846-5](https://doi.org/10.1016/S0140-6736(17)32846-5)
- Navarro, D. M. A. F., de Oliveira, P. E. S., Potting, R. P. J., Brito, A. C., Fital, S. J. F., & Sant'Ana, A. E. G. (2003a). The potential attractant or repellent effects of different water types on oviposition in *Aedes aegypti* L. (Dipt., Culicidae). *Journal of Applied Entomology*, 127(1), 46–50. <https://doi.org/10.1046/j.1439-0418.2003.00690.x>
- Navarro, D. M. A. F., de Oliveira, P. E. S., Potting, R. P. J., Brito, A. C., Fital, S. J. F., & Sant'Ana, A. E. G. (2003b). The potential attractant or repellent effects of different water types on oviposition in *Aedes aegypti* L. (Dipt., Culicidae). *Journal of Applied Entomology*, 127(1), 46–50. <https://doi.org/10.1046/j.1439-0418.2003.00690.x>
- Nazni, W., Lee, H., & Azahari, A. (2005). Adult and larval insecticide susceptibility status of *Culex quinquefasciatus* (Say) mosquitoes in Kuala Lumpur Malaysia. *Tropical Biomedicine*, 22(1), 63–68.
- Neale, J. T., & Juliano, S. A. (2019). Finding the sweet spot: What levels of larval mortality lead to compensation or overcompensation in adult production? *Ecosphere*, 10(9). <https://doi.org/10.1002/ecs2.2855>
- Nederstigt, T. A. P., Peijnenburg, W. J. G. M., Blom, R., & Vijver, M. G. (2022). Correlation analysis of single- and multigenerational endpoints in *Daphnia magna* toxicity tests: A case-study using TiO<sub>2</sub> nanoparticles. *Ecotoxicology and Environmental Safety*, 241, 113792. <https://doi.org/10.1016/j.ecoenv.2022.113792>
- Neiderud, C.-J. (2015). How urbanization affects the epidemiology of emerging infectious diseases. *Infection Ecology & Epidemiology*, 5(1), 27060. <https://doi.org/10.3402/iee.v5.27060>

- Nelson, G. C., Bennett, E., Berhe, A. A., Cassman, K., DeFries, R., Dietz, T., Dobermann, A., Dobson, A., Janetos, A., Levy, M., Marco, D., Nakicenovic, N., O'Neill, B., Norgaard, R., Petschel-Held, G., Ojima, D., Pingali, P., Watson, R., & Zurek, M. (2006). Anthropogenic Drivers of Ecosystem Change: An Overview. *Ecology and Society*, 11(2), art29. <https://doi.org/10.5751/ES-01826-110229>
- Newell, R. C. (1966). Effect of Temperature on the Metabolism of Poikilotherms. *Nature*, 212(5060), 426–428. <https://doi.org/10.1038/212426a0>
- Niederegger, S., Pastuschek, J., & Mall, G. (2010). Preliminary studies of the influence of fluctuating temperatures on the development of various forensically relevant flies. *Forensic Science International*, 199(1–3), 72–78. <https://doi.org/10.1016/j.forsciint.2010.03.015>
- Nikookar, S. H., Moosa-Kazemi, S. H., Yaghoobi-Ershadi, M. R., Vatandoost, H., Oshaghi, M. A., Ataei, A., & Anjamrooz, M. (2015). Fauna and Larval Habitat Characteristics of Mosquitoes in Neka County, Northern Iran. *Journal of Arthropod-Borne Diseases*, 9(2), 253–266.
- Nilsson, L. K. J., Sharma, A., Bhatnagar, R. K., Bertilsson, S., & Terenius, O. (2018). Presence of *Aedes* and *Anopheles* mosquito larvae is correlated to bacteria found in domestic water-storage containers. *FEMS Microbiology Ecology*, 94(6). <https://doi.org/10.1093/femsec/fiy058>
- Ohba, S., & Ushio, M. (2015). Effect of water depth on predation frequency by diving beetles on mosquito larvae prey: Water depth and predation in mosquitoes. *Entomological Science*, 18(4), Article 4. <https://doi.org/10.1111/ens.12143>
- Ohba, S.-Y., & Takagi, M. (2010). Predatory Ability of Adult Diving Beetles on the Japanese Encephalitis Vector *Culex tritaeniorhynchus*. *Journal of the American Mosquito Control Association*, 26(1), 32–36. <https://doi.org/10.2987/09-5946.1>
- Ortiz, D. I., Piche-Ovares, M., Romero-Vega, L. M., Wagman, J., & Troyo, A. (2022). The Impact of Deforestation, Urbanization, and Changing Land Use Patterns on the Ecology of Mosquito and Tick-Borne Diseases in Central America. *Insects*, 13(1), Article 1. <https://doi.org/10.3390/insects13010020>
- Ortiz Perea, N., & Callaghan, A. (2017). Pond dyes are *Culex* mosquito oviposition attractants. *PeerJ*, 5, e3361. <https://doi.org/10.7717/peerj.3361>

## References

---

- Oude Essink, G. H. P., van Baaren, E. S., & de Louw, P. G. B. (2010). Effects of climate change on coastal groundwater systems: A modeling study in the Netherlands. *Water Resources Research*, 46(10), 2009WR008719. <https://doi.org/10.1029/2009WR008719>
- Paaijmans, K. P., Heinig, R. L., Seliga, R. A., Blanford, J. I., Blanford, S., Murdock, C. C., & Thomas, M. B. (2013). Temperature variation makes ectotherms more sensitive to climate change. *Global Change Biology*, 19(8), 2373–2380. <https://doi.org/10.1111/gcb.12240>
- Paaijmans, K. P., Jacobs, A. F. G., Takken, W., Heusinkveld, B. G., Githeko, A. K., Dicke, M., & Holtslag, A. a. M. (2008). Observations and model estimates of diurnal water temperature dynamics in mosquito breeding sites in western Kenya. *Hydrological Processes*, 22(24), 4789–4801. <https://doi.org/10.1002/hyp.7099>
- Paris, M., Tetreau, G., Laurent, F., Lelu, M., Despres, L., & David, J.-P. (2011). Persistence of *Bacillus thuringiensis israelensis* (Bti) in the environment induces resistance to multiple Bti toxins in mosquitoes. *Pest Management Science*, 67(1), 122–128. <https://doi.org/10.1002/ps.2046>
- Patrick, M. L., & Bradley, T. J. (2000). Regulation of compatible solute accumulation in larvae of the mosquito *Culex tarsalis*: Osmolarity versus salinity. *The Journal of Experimental Biology*, 203, 831–839. <https://doi.org/10.1242/jeb.203.4.831>
- Pauw, P., de Louw, P. G. B., & Essink, G. H. P. O. (2012). Groundwater salinisation in the Wadden Sea area of the Netherlands: Quantifying the effects of climate change, sea-level rise and anthropogenic interferences. *Netherlands Journal of Geosciences - Geologie En Mijnbouw*, 91(3), 373–383. <https://doi.org/10.1017/S0016774600000500>
- Peck, G. W., & Walton, W. E. (2006). Effect of Bacterial Quality and Density on Growth and Whole Body Stoichiometry of *Culex quinquefasciatus* and *Culex tarsalis* (Diptera: Culicidae). *Journal of Medical Entomology*, 43(1), 25–33. <https://doi.org/10.1093/jmedent/43.1.25>
- Petrić, D., Bellini, R., Scholte, E.-J., Rakotoarivony, L., & Schaffner, F. (2014). Monitoring population and environmental parameters of invasive mosquito species in Europe. *Parasites and Vectors*, 7(1), 1–14. <https://doi.org/10.1186/1756-3305-7-187>
- Pilger, D., De Maesschalck, M., Horstick, O., & San Martin, J. L. (2010). Dengue outbreak response: Documented effective interventions and evidence gaps. *TropiKA.Net*, 1(1), 0–0. [http://journal.tropika.net/scielo.php?script=sci\\_abstract&pid=S2078-86062010000100002&lng=es&nrm=iso&tlng=en](http://journal.tropika.net/scielo.php?script=sci_abstract&pid=S2078-86062010000100002&lng=es&nrm=iso&tlng=en)

- Poopathi, S., & Abidha, S. (n.d.). Mosquitocidal bacterial toxins (*Bacillus sphaericus* and *Bacillus thuringiensis* serovar israelensis): Mode of action, cytopathological effects and mechanism of resistance. <https://doi.org/10.5897/JJAP.9000019>
- Potter, M. S. (2023). *Hard Clam (Mercenaria mercenaria L.) Response to a Warming Environment: A Mesocosm Experiment*. <https://www.proquest.com/openview/adf266ea2d1c716ead3892e270a2e7c0/1?pq-origsite=gscholar&cbl=18750&diss=y>
- Priyadarshana, T. S., & Slade, E. M. (2023). A meta-analysis reveals that dragonflies and damselflies can provide effective biological control of mosquitoes. *Journal of Animal Ecology*, 92(8), 1589–1600. <https://doi.org/10.1111/1365-2656.13965>
- R Core Team. (2018). *R: A Language and Environment for Statistical Computing*. R Foundation for Statistical Computing. <https://www.R-project.org/>
- Radrova, J., Seblova, V., & Votypka, J. (2013). Feeding Behavior and Spatial Distribution of *Culex* Mosquitoes (Diptera: *Culicidae*) in Wetland Areas of the Czech Republic. *Journal of Medical Entomology*, 50(5), 1097–1104. <https://doi.org/10.1603/ME13029>
- Raghavendra, K., Sharma, P., & Dash, A. P. (2007). Biological control of mosquito populations through frogs: Opportunities & constrains. *Indian J Med Res*, 128(1), 4. <https://pubmed.ncbi.nlm.nih.gov/18820354/>
- Ramasamy, R., & Surendran, S. N. (2012). Global Climate Change and Its Potential Impact on Disease Transmission by Salinity-Tolerant Mosquito Vectors in Coastal Zones. *Frontiers in Physiology*, 3. <https://doi.org/10.3389/fphys.2012.00198>
- Ramasamy, R., & Surendran, S. N. (2016). Mosquito vectors developing in atypical anthropogenic habitats: Global overview of recent observations, mechanisms and impact on disease transmission. *J Vector Borne Dis*, 9.
- Ranta, E., McManus, J., & Leikola, N. (1990). Non-Visual Detection of Prey Patches by the Smooth Newt (*Triturus vulgaris*). *Journal of Herpetology*, 24(2), 202–204. <https://doi.org/10.2307/1564231>
- Rao, K. P., & Bullock, T. H. (1954). Q10 as a Function of Size and Habitat Temperature in Poikilotherms. *The American Naturalist*. <https://doi.org/10.1086/281806>
- Rasmussen, L. (1998). Effects of afforestation and deforestation on the deposition, cycling and leaching of elements. *Agriculture, Ecosystems & Environment*, 67(2), 153–159. [https://doi.org/10.1016/S0167-8809\(97\)00113-8](https://doi.org/10.1016/S0167-8809(97)00113-8)

## References

---

- Ratte, H. T. (1984). Temperature and Insect Development. In K. H. Hoffmann (Ed.), *Environmental Physiology and Biochemistry of Insects* (pp. 33–66). Springer Berlin Heidelberg. [https://doi.org/10.1007/978-3-642-70020-0\\_2](https://doi.org/10.1007/978-3-642-70020-0_2)
- Reisen, W. K., Milby, M. M., & Bock, M. E. (1984). The effects of immature stress on selected events in the life history of *Culex tarsalis*. *Mosq. News.*, 44(3), 385–395.
- Rejmánková, E., Grieco, J., Achee, N., & Roberts, D. R. (2013a). Ecology of Larval Habitats. In S. Manguin (Ed.), *Anopheles mosquitoes—New insights into malaria vectors*. InTech. <https://doi.org/10.5772/55229>
- Ritz, C., Baty, F., Streibig, J. C., & Gerhard, D. (2015). Dose-Response Analysis Using R. *PLOS ONE*, 10(e0146021). <http://journals.plos.org/plosone/article?id=10.1371/journal.pone.0146021>
- Rivero, A., Magaud, A., Nicot, A., & Vézilier, J. (2011). Energetic Cost of Insecticide Resistance in *Culex pipiens* Mosquitoes. *Journal of Medical Entomology*, 48(3), 694–700. <https://doi.org/10.1603/ME10121>
- Roberts, D. (1996). Mosquitoes (Diptera: Culicidae) Breeding in Brackish Water: Female Ovipositional Preferences or Larval Survival? *Journal of Medical Entomology*, 33(4), 525–530. <https://doi.org/10.1093/jmedent/33.4.525>
- Roberts, D. M., & Irving-Bell, R. J. (1997). Salinity and microhabitat preferences in mosquito larvae from southern Oman. *Journal of Arid Environments*, 37(3), 497–504. <https://doi.org/10.1006/jare.1997.0291>
- Robich, R. M., & Denlinger, D. L. (2005). Diapause in the mosquito *Culex pipiens* evokes a metabolic switch from blood feeding to sugar gluttony. *Proceedings of the National Academy of Sciences*, 102(44), 15912–15917. <https://doi.org/10.1073/pnas.0507958102>
- Roche, B., Léger, L., L'Ambert, G., Lacour, G., Foussadier, R., Besnard, G., Barré-Cardi, H., Simard, F., & Fontenille, D. (2015). The Spread of *Aedes albopictus* in Metropolitan France: Contribution of Environmental Drivers and Human Activities and Predictions for a Near Future. *PLOS ONE*, 10(5), e0125600. <https://doi.org/10.1371/journal.pone.0125600>
- Rochlin, I., Faraji, A., Ninivaggi, D. V., Barker, C. M., & Kilpatrick, A. M. (2016). Anthropogenic impacts on mosquito populations in North America over the past century. *Nature Communications*, 7(1), 13604. <https://doi.org/10.1038/ncomms13604>

- Rockett, C. L. (1987). Bacteria as Ovipositional Attractants for *Culex pipiens* (Diptera: Culicidae). *The Great Lakes Entomologist*, 20(3), 6.
- Romeo-Aznar, V., Paul, R., Telle, O., & Pascual, M. (2018). Mosquito-borne transmission in urban landscapes: The missing link between vector abundance and human density. *Proceedings of the Royal Society B: Biological Sciences*, 285(1884), 20180826. <https://doi.org/10.1098/rspb.2018.0826>
- Roşca, I., Gherghel, I., Strugariu, A., & Zamfirescu, Ş. R. (2013). Feeding ecology of two newt species (*Triturus cristatus* and *Lissotriton vulgaris*) during the reproduction season. *Knowledge and Management of Aquatic Ecosystems*, 408, Article 408. <https://doi.org/10.1051/kmae/2013040>
- Roser, M., Ritchie, H., & Spooner, F. (2021). Burden of Disease. *Our World in Data*.
- Rubbo, M. J., Lanterman, J. L., Falco, R. C., & Daniels, T. J. (2011). The Influence of Amphibians on Mosquitoes in Seasonal Pools: Can Wetlands Protection Help to Minimize Disease Risk? *Wetlands*, 31(4), 799–804. <https://doi.org/10.1007/s13157-011-0198-z>
- Sacco, P. L., Valle, F., & Domenico, M. D. (2023). Proactive vs. Reactive country responses to the COVID-19 pandemic shock. *PLOS Global Public Health*, 3(1), e0001345. <https://doi.org/10.1371/journal.pgph.0001345>
- Saha, N., Aditya, G., Saha, G. K., & Hampton, S. E. (2010). Opportunistic foraging by heteropteran mosquito predators. *Aquatic Ecology*, 44(1), 167–176. <https://doi.org/10.1007/s10452-009-9250-y>
- Saleeza, S. N. R., Norma-Rashid, Y., & Sofian-Azirun, M. (2014). Guppies as predators of common mosquito larvae in Malaysia. *The Southeast Asian Journal of Tropical Medicine and Public Health*, 45(2), 299–308.
- Sames, W. J., Schleich, S. S., & Johnson, O. D. (2005). Egg raft size and biological notes on *culiseta incidens theobald* in western Washington. *Journal of the American Mosquito Control Association*, 21(4), 469–471. [https://doi.org/10.2987/8756-971X\(2006\)21\[469:ERSABN\]2.0.CO;2](https://doi.org/10.2987/8756-971X(2006)21[469:ERSABN]2.0.CO;2)
- Sas, I., Kovács, É.-H., Covaciu-Marcov, S.-D., Strugariu, A., Covaci, R., & Ferenczi, S. (2007). Food habits of a Pool frog *Pelophylax lessonae* – Edible frog *Pelophylax kl. Esulentus* population from North- Western Romania.

## References

---

- Sas, I., Marcov, S. D. C., Strugariu, A., David, A., & Ilea, C. (2009). Food Habit of *Rana (Pelophylax) kl. Esculenta* Females in a New Recorded E-System Population from a Forested Habitat in North-Western Romania. *Turkish Journal of Zoology*. <https://doi.org/10.3906/zoo-0702-8>
- Schmork, S., & Mercado, A. (1969). Upconing of Fresh Water-Sea Water Interface Below Pumping Wells, Field Study. *Water Resources Research*, 5(6), 1290–1311. <https://doi.org/10.1029/WR005i006p01290>
- Schmutzer, A. C., Gray, M. J., Burton, E. C., & Miller, D. L. (2008). Impacts of cattle on amphibian larvae and the aquatic environment. *Freshwater Biology*, 53(12), 2613–2625. <https://doi.org/10.1111/j.1365-2427.2008.02072.x>
- Schrama, M., Gorsich, E. E., Hunting, E. R., Barmantlo, S. H., Beechler, B., & van Bodegom, P. M. (2018). Eutrophication and predator presence overrule the effects of temperature on mosquito survival and development. *PLOS Neglected Tropical Diseases*, 12(3), e0006354. <https://doi.org/10.1371/journal.pntd.0006354>
- Schrama, M., Hunting, E. R., Beechler, B. R., Guarido, M. M., Govender, D., Nijland, W., van 't Zelfde, M., Venter, M., van Bodegom, P. M., & Gorsich, E. E. (2020). Human practices promote presence and abundance of disease-transmitting mosquito species. *Scientific Reports*, 10(1), 13543. <https://doi.org/10.1038/s41598-020-69858-3>
- Schuler, M. S., & Relyea, R. A. (2018). Road salt and organic additives affect mosquito growth and survival: An emerging problem in wetlands. *Oikos*, 127(6), 866–874. <https://doi.org/10.1111/oik.04837>
- Ser, O., & Cetin, H. (2019). Investigation of Susceptibility Levels of *Culex pipiens* L. (Diptera: Culicidae) Populations to Synthetic Pyrethroids in Antalya Province of Turkey. *Journal of Arthropod-Borne Diseases*, 13(3), 243–258.
- Setha, T., Chantha, N., & Socheat, D. (2007). Efficacy of *Bacillus thuringiensis israelensis*, vectobac® wg and dt, formulations against dengue mosquito vectors in cement potable water jars in cambodia. *SOUTHEAST ASIAN J TROP MED PUBLIC HEALTH*, 38(2).
- Shalan, E. A.-S., & Canyon, D. V. (2009). Aquatic insect predators and mosquito control. *Tropical Biomedicine*, 26, 223–261. <http://www.msptm.org/journal14.html>

- Shapiro, L. L. M., Whitehead, S. A., & Thomas, M. B. (2017). Quantifying the effects of temperature on mosquito and parasite traits that determine the transmission potential of human malaria. *PLOS Biology*, 15(10), e2003489. <https://doi.org/10.1371/journal.pbio.2003489>
- Shelton, R. M. (1973). The effect of temperatures on development of eight mosquito species. *Mosquito News*, 33(1), 1–12. <https://www.cabdirect.org/cabdirect/abstract/19732902146>
- Sih, A. (1986). Antipredator Responses and the Perception of Danger by Mosquito Larvae. *Ecology*, 67(2), Article 2. <https://doi.org/10.2307/1938587>
- Silberbush, A., Blaustein, L., & Margalith, Y. (2005). Influence of Salinity Concentration on Aquatic Insect Community Structure: A Mesocosm Experiment in the Dead Sea Basin Region. *Hydrobiologia*, 548(1), 1–10. <https://doi.org/10.1007/s10750-004-8336-8>
- Silberbush, A., Tsurim, I., Margalith, Y., & Blaustein, L. (2014). Interactive effects of salinity and a predator on mosquito oviposition and larval performance. *Oecologia*, 175(2), 565–575. <https://doi.org/10.1007/s00442-014-2930-x>
- Silverberg, N., Gagnon, J. M., & Lee, K. (1995). A benthic mesocosm facility for maintaining soft-bottom sediments. *Netherlands Journal of Sea Research*, 34(4), 289–302. [https://doi.org/10.1016/0077-7579\(95\)90039-X](https://doi.org/10.1016/0077-7579(95)90039-X)
- Smith, D. R. & Huang, C. (2010). Assessing Nutrient Transport Following Dredging of Agricultural Drainage Ditches. *Transactions of the ASABE*, 53(2), 429–436. <https://doi.org/10.13031/2013.29583>
- Sougué, E., Dabiré, R. K., & Roux, O. (2021). Larval habitat selection by females of two malaria vectors in response to predation risk. *Acta Tropica*, 221, 106016. <https://doi.org/10.1016/j.actatropica.2021.106016>
- Spanoudis, C. G., Andreadis, S. S., Tsaknis, N. K., Petrou, A. P., Gkeka, C. D., & Savopoulou-Soultani, M. (2019). Effect of Temperature on Biological Parameters of the West Nile Virus Vector *Culex pipiens* form 'molestus' (Diptera: Culicidae) in Greece: Constant vs Fluctuating Temperatures. *Journal of Medical Entomology*, 56(3), 641–650. <https://doi.org/10.1093/jme/tjy224>

## References

---

- Steffen, W., Richardson, K., Rockström, J., Cornell, S. E., Fetzer, I., Bennett, E. M., Biggs, R., Carpenter, S. R., de Vries, W., de Wit, C. A., Folke, C., Gerten, D., Heinke, J., Mace, G. M., Persson, L. M., Ramanathan, V., Reyers, B., & Sörlin, S. (2015). Planetary boundaries: Guiding human development on a changing planet. *Science*, 347(6223), 1259855. <https://doi.org/10.1126/science.1259855>
- Steiger, D. M., Johnson, P., Hilbert, D. W., Ritchie, S., Jones, D., & Laurance, S. G. W. (2011). Effects of landscape disturbance on mosquito community composition in tropical Australia. *37*(1).
- Steiger, D. M., Johnson, P., Hilbert, D. W., Ritchie, S., Jones, D., & Laurance, S. G. W. (2012). Effects of landscape disturbance on mosquito community composition in tropical Australia. *Journal of Vector Ecology*, 37(1), 69–76. <https://doi.org/10.1111/j.1948-7134.2012.00201.x>
- Sternberg, E. D., & Thomas, M. B. (2014). Local adaptation to temperature and the implications for vector-borne diseases. *Trends in Parasitology*, 30(3), 115–122. <https://doi.org/10.1016/j.pt.2013.12.010>
- Stott, P. (2016). How climate change affects extreme weather events. *Science*, 352(6293), 1517–1518. <https://doi.org/10.1126/science.aaf7271>
- Su, M., Jiang, Z., & Hui, C. (2022). How Multiple Interaction Types Affect Disease Spread and Dilution in Ecological Networks. *Frontiers in Ecology and Evolution*, 10. <https://doi.org/10.3389/fevo.2022.862986>
- Sukiato, F., Wasserman, R. J., Foo, S. C., Wilson, R. F., & Cuthbert, R. N. (2019). The effects of temperature and shading on mortality and development rates of *Aedes aegypti* (Diptera: Culicidae). *Journal of Vector Ecology*, 44(2), 264–270. <https://doi.org/10.1111/jvec.12358>
- Talaga, S., Dejean, A., Azémar, F., Dumont, Y., & Leroy, C. (2020). Impacts of biotic and abiotic parameters on immature populations of *Aedes aegypti*. *Journal of Pest Science*, 93(3), 941–952. <https://doi.org/10.1007/s10340-020-01214-w>
- Tatem, A. J., Huang, Z., Das, A., Qi, Q., Roth, J., & Qiu, Y. (2012). Air travel and vector-borne disease movement. *Parasitology*, 139(14), 1816–1830. <https://doi.org/10.1017/S0031182012000352>
- Telesh, I., Schubert, H., & Skarlato, S. (2013). Life in the salinity gradient: Discovering mechanisms behind a new biodiversity pattern. *Estuarine, Coastal and Shelf Science*, 135, 317–327. <https://doi.org/10.1016/j.ecss.2013.10.013>

- Thamer, N. K., & Abdulsamad, S. M. S. (2005). The Effect of Different NaCl and pH Levels on the Survival of *Culex sp.* (Diptera; *Culicidae*) Larvae in Basrah. *Journal of Basrah Researches (Sciences)*, 31(2a), 31–36. <https://www.iasj.net/iasj/download/48dd73e8b59b4889>
- Thomas, J. A., Welch, J. J., Lanfear, R., & Bromham, L. (2010). A Generation Time Effect on the Rate of Molecular Evolution in Invertebrates. *Molecular Biology and Evolution*, 27(5), 1173–1180. <https://doi.org/10.1093/molbev/msq009>
- Thompson, D. A., Lehmler, H.-J., Kolpin, D. W., Hladik, M. L., Vargo, J. D., Schilling, K. E., LeFevre, G. H., Peeples, T. L., Poch, M. C., LaDuca, L. E., Cwiertny, D. M., & Field, R. W. (2020). A critical review on the potential impacts of neonicotinoid insecticide use: Current knowledge of environmental fate, toxicity, and implications for human health. *Environmental Science: Processes & Impacts*, 22(6), 1315–1346. <https://doi.org/10.1039/C9EM00586B>
- Thongsripong, P., Hyman, J. M., Kapan, D. D., & Bennett, S. N. (2021). Human–Mosquito Contact: A Missing Link in Our Understanding of Mosquito-Borne Disease Transmission Dynamics. *Annals of the Entomological Society of America*, 114(4), 397–414. <https://doi.org/10.1093/aesa/saab011>
- Tran, T. T., Janssens, L., Dinh, K. V., & Stoks, R. (2018). Transgenerational interactions between pesticide exposure and warming in a vector mosquito. *Evolutionary Applications*, 11(6), 906–917. <https://doi.org/10.1111/eva.12605>
- Tuno, N., Miki, K., Minakawa, N., Githeko, A., Yan, G., & Takagi, M. (2004). Diving Ability of *Anopheles gambiae* (Diptera: *Culicidae*) Larvae. *Journal of Medical Entomology*, 41(4), 810–812. <https://doi.org/10.1603/0022-2585-41.4.810>
- Tyler, M. J. (1958). On the diet and feeding habits of the edible frog (*Rana esculenta* linnaeus). *Proceedings of the Zoological Society of London*, 131(4), 583–595. <https://doi.org/10.1111/j.1096-3642.1958.tb00703.x>
- Ukubuiwe, C. A., Olayemi, I. K., Omalu, I. C., Arimoro, F. O., Odeyemi, M. O., Salihu, I. M., Jibrin, A. I., Ukubuiwe, C. C., & Yunusa, R. Y. (2017). Influence of photoperiod on larval growth indices and energy budget for metamorphosis in *Culex quinquefasciatus* mosquito (Diptera: *Culicidae*); its implication in integrated vector management. <http://repository.futminna.edu.ng:8080/jspui/handle/123456789/3659>

## References

---

- Vajedsamiei, J., Melzner, F., Raatz, M., Morón Lugo, S. C., & Pansch, C. (2021). Cyclic thermal fluctuations can be burden or relief for an ectotherm depending on fluctuations' average and amplitude. *Functional Ecology*, 35(11), 2483–2496. <https://doi.org/10.1111/1365-2435.13889>
- van Baaren, E., & Oude Essink, G. H. P. (2009). *Verzilting van het Nederlandse grondwatersysteem (0903–0026)*. Deltares.
- Van Der Have, T. M., & De Jong, G. (1996). Adult Size in Ectotherms: Temperature Effects on Growth and Differentiation. *Journal of Theoretical Biology*, 183(3), 329–340. <https://doi.org/10.1006/jtbi.1996.0224>
- van der Sluijs, J. P. (2020). Insect decline, an emerging global environmental risk. *Current Opinion in Environmental Sustainability*, 46, 39–42. <https://doi.org/10.1016/j.cosust.2020.08.012>
- van Dijk, G., Lamers, L. P. M., Loeb, R., Westendorp, P.-J., Kuiperij, R., van Kleef, H. H., Klinge, M., & Smolders, A. J. P. (2019). Salinization lowers nutrient availability in formerly brackish freshwater wetlands; unexpected results from a long-term field experiment. *Biogeochemistry*, 143(1), 67–83. <https://doi.org/10.1007/s10533-019-00549-6>
- Van Schie, C., Spafford, H., Carver, S., & Weinstein, P. (2009). Salinity tolerance of *Aedes camptorhynchus* (Diptera: *Culicidae*) from two regions in southwestern Australia. *Australian Journal of Entomology*, 48(4), 293–299. <https://doi.org/10.1111/j.1440-6055.2009.00719.x>
- Verberk, W. C. E. P., Siepel, H., & Esselink, H. (2008). Life-history strategies in freshwater macroinvertebrates. *Freshwater Biology*, 53(9), 1722–1738. <https://doi.org/10.1111/j.1365-2427.2008.02035.x>
- Versteirt, V., Boyer, S., Damiens, D., De Clercq, E. M., Dekoninck, W., Ducheyne, E., Grootaert, P., Garros, C., Hance, T., Hendrickx, G., Coosemans, M., & Van Bortel, W. (2013). Nationwide inventory of mosquito biodiversity (Diptera: *Culicidae*) in Belgium, Europe. *Bulletin of Entomological Research*, 103(2), 193–203. <https://doi.org/10.1017/S0007485312000521>
- Vezzani, D., & Albicocco, A. P. (2009). The effect of shade on the container index and pupal productivity of the mosquitoes *Aedes aegypti* and *Culex pipiens* breeding in artificial containers. *Medical and Veterinary Entomology*, 23(1), 78–84. <https://doi.org/10.1111/j.1365-2915.2008.00783.x>

- Viaene, K. (2016). Improving ecological realism in the risk assessment of chemicals: Development of an integrated model. Ghent University.
- Virginio, F., Oliveira Vidal, P., & Suesdek, L. (2015a). Wing sexual dimorphism of pathogen-vector culicids. *Parasites & Vectors*, 8(1), 159. <https://doi.org/10.1186/s13071-015-0769-6>
- Virginio, F., Oliveira Vidal, P., & Suesdek, L. (2015b). Wing sexual dimorphism of pathogen-vector culicids. *Parasites & Vectors*, 8(1), 159. <https://doi.org/10.1186/s13071-015-0769-6>
- Vlaskamp, D. R., Thijsen, S. F., Reimerink, J., Hilken, P., Bouvy, W. H., Bantjes, S. E., Vlamincx, B. J., Zaaier, H., van den Kerkhof, H. H., Raven, S. F., & Reusken, C. B. (2020). First autochthonous human West Nile virus infections in the Netherlands, July to August 2020. *Eurosurveillance*, 25(46). <https://doi.org/10.2807/1560-7917.ES.2020.25.46.2001904>
- Wallis, R. C. (1954). A study of oviposition activity of mosquitoes. *American Journal of Hygiene*, 60(2), Article 2.
- Waqas, M. S., Lin, L., Shoaib, A. A. Z., Cheng, X., Zhang, Q., Elabasy, A. S. S., & Shi, Z. (2020). Effect of Constant and Fluctuating Temperature on the Development, Reproduction, Survival, and Sex Ratio of *Phenacoccus solenopsis* (Hemiptera: Pseudococcidae). *Environmental Entomology*, 49(3), 553–560. <https://doi.org/10.1093/ee/nvaa023>
- Waters, S., Webster-Brown, J. G., & Hawes, I. (2021). The release of legacy phosphorus from deforestation-derived sediments in shallow, coastal lake Forsyth/Te Roto o Wairewa. *New Zealand Journal of Marine and Freshwater Research*, 55(3), 446–465. <https://doi.org/10.1080/00288330.2020.1804408>
- Weterings, R. (2015). Tadpoles of three common anuran species from Thailand do not prey on mosquito larvae. *Journal of Vector Ecology*, 40(2), Article 2. <https://doi.org/10.1111/jvec.12158>
- Wheat, D. (2011). Arduino Software. In D. Wheat (Ed.), *Arduino Internals* (pp. 89–97). Apress. [https://doi.org/10.1007/978-1-4302-3883-6\\_5](https://doi.org/10.1007/978-1-4302-3883-6_5)

## References

---

- Whitmee, S., Haines, A., Beyrer, C., Boltz, F., Capon, A. G., Dias, B. F. de S., Ezeh, A., Frumkin, H., Gong, P., Head, P., Horton, R., Mace, G. M., Marten, R., Myers, S. S., Nishtar, S., Osofsky, S. A., Pattanayak, S. K., Pongsiri, M. J., Romanelli, C., ... Yach, D. (2015). Safeguarding human health in the Anthropocene epoch: Report of The Rockefeller Foundation–Lancet Commission on planetary health. *The Lancet*, 386(10007), 1973–2028. [https://doi.org/10.1016/S0140-6736\(15\)60901-1](https://doi.org/10.1016/S0140-6736(15)60901-1)
- WHO. (2014). Factsheet Vector-borne diseases (Factsheet 387; WHO Factsheet). WHO. [https://extranet.who.int/kobe\\_centre/sites/default/files/pdf/vbdfactsheet.pdf](https://extranet.who.int/kobe_centre/sites/default/files/pdf/vbdfactsheet.pdf)
- Why, A. M., Lara, J. R., & Walton, W. E. (2016). Oviposition of *Culex tarsalis* (Diptera: Culicidae) Differs on Water Conditioned by Potential Fish and Insect Predators. *Journal of Medical Entomology*, 53(5), 1093–1099. <https://doi.org/10.1093/jme/tjw064>
- Wong, J., Morrison, A. C., Stoddard, S. T., Astete, H., Chu, Y. Y., Baseer, I., & Scott, T. W. (2012). Linking Oviposition Site Choice to Offspring Fitness in *Aedes aegypti*: Consequences for Targeted Larval Control of Dengue Vectors. *PLOS Neglected Tropical Diseases*, 6(5), e1632. <https://doi.org/10.1371/journal.pntd.0001632>
- Wu, L., Huang, K., Ridoutt, B. G., Yu, Y., & Chen, Y. (2021). A planetary boundary-based environmental footprint family: From impacts to boundaries. *Science of The Total Environment*, 785, 147383. <https://doi.org/10.1016/j.scitotenv.2021.147383>
- Wu, T.-H., Shiao, S.-F., & Okuyama, T. (2015). Development of insects under fluctuating temperature: A review and case study. *Journal of Applied Entomology*, 139(8), 592–599. <https://doi.org/10.1111/jen.12196>
- Wynn, G., & Paradise, C. J. (2001). Effects of microcosm scaling and food resources on growth and survival of larval *Culex pipiens*. *BMC Ecology*, 1(1), 3. <https://doi.org/10.1186/1472-6785-1-3>
- Yee, D. A., Glasgow, W. C., & Ezeakacha, N. F. (2020). Quantifying species traits related to oviposition behavior and offspring survival in two important disease vectors. *PLOS ONE*, 15(9), e0239636. <https://doi.org/10.1371/journal.pone.0239636>
- Zhou, G., & Miesfeld, R. L. (2009). Energy metabolism during diapause in *Culex pipiens* mosquitoes. *Journal of Insect Physiology*, 55(1), 40–46. <https://doi.org/10.1016/j.jinsphys.2008.10.002>

- Zhu, L., Gong, H., Li, X., Wang, R., Chen, B., Dai, Z., & Teatini, P. (2015). Land subsidence due to groundwater withdrawal in the northern Beijing plain, China. *Engineering Geology*, 193, 243–255. <https://doi.org/10.1016/j.enggeo.2015.04.020>



Summary

## Summary

## Summary

---

Anthropogenic change has significantly altered ecological systems. There is substantial worry that this will lead to increased transmission of infectious disease. As such, establishing relations between elements of anthropogenic change and infectious disease is a key challenge. In Europe, current morbidity caused by infectious diseases is comparatively low, which stands out in contrast to its history. Investigating current changes in land-use, water management and climate from a One Health perspective – which acknowledges the interconnectedness between human, animal and environmental health – aids in preparedness against (re-)emergence.

Among the various mechanisms through which infectious disease pathogens spread, arthropods, and mosquitoes specifically, play a crucial role as vector. These mosquito-borne diseases are dependent on their vector for transmission. Understanding how changes in the interplay between the environment, vector populations, and animal and human hosts relate to the increasing incidence and spread of pathogens, is crucial in anticipating and mitigating outbreaks.

Even though often complex, ecological processes are central to this understanding. Currently, most One Health studies rely on simplified lab experiments or isolated effects, thereby lacking ecological realism and relevance. In this thesis I aim to identify the main anthropogenic impacts on the cosmopolitan disease vector *Culex pipiens*' population dynamics, whilst demonstrating the importance of including ecological complexity. To this end, I limited myself to interactions between and within bottom-up, top-down and macro-environmental pressures impacting *Cx. pipiens* larvae.

### **Biting the hand that feeds**

Anthropogenic impacts like altered climate, nutrient pollution and water management affect larval mosquito habitats via key abiotic pressures, most notably temperature, eutrophication and salinization. These pressures are widely assumed to affect subadult development and survival, and (perceived) habitat quality during egg-laying, but interactive impacts are poorly understood. To assess relevant interactions between these selected pressures, I performed a series of full-factorial mesocosm experiments. My results suggest large and positive impacts of anthropogenic impacts on mosquito populations, including accelerated growth and increased survival. Many of these impacts are exacerbated by increasing temperatures.

Furthermore, I show that stressor impacts rarely operate in a vacuum, and instead often co-occur, stressing the importance of evaluating their interactions. As the processes upon which the stressors and their interactions act should be comparable across species, but with potentially differing relative importance, experiments including stressor interactions should be the norm. Doing so will provide a basis for the ecological complexity needed to translate experimental findings to ecosystems.

When striving for ecological realism, it is essential to consider not only ecological complexity, but also realistic stressor application (including cyclic fluctuations), contextualization of test populations, and synergies with mitigation measures. The following sections explore these themes through investigation of selected pressures.

### **In the heat of the moment**

Temperature is commonly acknowledged as one of the primary forces driving ectotherm vector populations. Although numerous experiments have been conducted on various species, the majority has been conducted using constant temperatures, while temperatures in nature follow diurnal fluctuations. Such temperature fluctuations have previously been described to impact metabolic processes at (sub)cellular level. In this thesis I developed an inexpensive method to study the impacts of temperature fluctuations in mesocosm experiments at the whole-organism level. By comparing the commonly used constant temperatures and block schemes to the simulated temperature fluctuation of an average day in June, I demonstrate that temperature fluctuations significantly decreased development time compared to constant temperatures. The majority of this difference occurs during the pupal development, when the mosquitoes do not eat, and interact the least with their environment.

Including natural fluctuations in temperature thus allows for a more accurate assessment of stressor impacts and its derived relative importance, which could have significant implications for the predicting the effects of large-scale disturbances in temperature regimes like climate-change.

### **Taking it with a grain of salt**

Salinization, exacerbated by sea-level rise, land subsidence and freshwater extraction is a critical environmental cue affecting freshwater ecosystems. Salinization is commonly acknowledged to negatively affect biodiversity and

## Summary

---

ecosystem services, but little is known about the direct and indirect effects of animal populations under transitory conditions. Physiological and behavioral adaptations in mosquitoes exist, resulting in species specific tolerances, within which *Cx. pipiens* is commonly considered intolerant. Nevertheless, gradual exposure combined with their relatively short generation times may have driven local adaptation. To assess whether local adaptation to salinization exists, I quantified and compared tolerance of three populations along a gradient from coast to inland, expecting an improved tolerance near the coast. Mortality was considerably lower than expected at the currently described maximum lethal dose (LD100), with negligible impacts on development rates. Salinity tolerance was highest in the coastal and inland populations, with a significantly lower tolerance for the intermediate population.

These variations in tolerance can be partially attributed to geographic origin and historical context. This highlights the need to consider the population used in experiments and the following need to communicate and contextualize the geographic origin of the populations used in experiments.

### Clashing in murky waters

There has been an increasing interest in One Health strategies like natural predation to combat mosquito-borne diseases, but at the same time we are witnessing widespread losses in biodiversity. In the last chapter of this thesis, I evaluated predator effectiveness against *Cx. pipiens*. We compared two European amphibians, the smooth newt (*Lissotriton vulgaris*) and middle green frog (*Pelophylax kl. Esculentus*) to the predatorial capacity of two ubiquitous invertebrates, including the two-spotted diving beetle (*Agabus bipustulatus*) and common backswimmer (*Notonecta glauca*). Results indicated that amphibians consumed 4-8 times more mosquito larvae than the selected invertebrates, with no significant differences between amphibian species, their sex, or eutrophication levels. Additionally, the presence of predators deterred mosquito egg-laying, suggesting a *landscape of fear*.

These findings underscore the potential of amphibians as natural mosquito control agents, both by limiting survival and preventing colonization altogether, emphasizing the need to prioritize conservation of these threatened species in both urban and rural landscapes.

**Concluding remarks**

Overall, results in this thesis emphasize the need to include ecological realism for accurate and relevant results that reach beyond their experimental setting. Especially within holistic and multidisciplinary frameworks like One Health, where interactions are the norm.

I have given an overview of the main anthropogenic drivers, and their interactions, acting on *Cx. pipiens* population dynamics. The findings thereby provide a foundation for predictions of how their populations will shift with our changing world. By furthering our understanding of the drivers that effective interventions should act on, this lays a basis for proactive mitigation of *Culex*-borne disease risk.



Samenvatting

## **Samenvatting**

## Samenvatting

Menselijke invloeden hebben ecologische systemen flink aangetast. Algemeen wordt er aangenomen dat dit aanzienlijke invloed heeft op de verspreiding van infectieziekten, wat kan leiden tot allerlei uitdagingen op het gebied van volksgezondheid. Onderzoek naar veranderingen in landgebruik, waterbeheer en klimaat vanuit een One Health-perspectief – dat de onderlinge verbondenheid tussen de gezondheid van mens, dier en milieu erkent – draagt bij aan het begrip van, en de eventuele voorbereiding op, (her)opkomst van ziekten.

Onder de verschillende mechanismen waardoor pathogenen zich verspreiden, spelen ongewervelden, en specifiek muggen, een cruciale rol als vector. Deze door muggen overdraagbare ziekten zijn afhankelijk van hun vector voor overdracht. Om beter te kunnen anticiperen op uitbraken van vector-overgedragen ziekten, is het belangrijk om inzicht te krijgen in het samenspel tussen vectorpopulaties, hun gastheren, en het milieu.

Hoewel vaak complex, is een beter inzicht in de onderliggende ecologische processen essentieel in deze benadering. Veel One Health-studies baseren zich op vereenvoudigde laboratoriumexperimenten of geïsoleerde effecten, waardoor ecologisch realisme en/of relevantie beperkt is. In deze thesis identificeer ik de belangrijkste menselijke invloeden op de populatiedynamiek van de wereldwijd verspreide ziektevector *Culex pipiens* s.l. (ofwel de gewone huismug), en probeer ik de ecologisch realistische impact in experimenten te onderzoeken. Hiervoor heb ik mij beperkt tot interacties tussen en binnen waterkwaliteit, biotiek (competitie en predatie) en klimaat drukfactoren.

### **Biting the hand that feeds**

De habitats van muggenlarven worden door mensen aangetast via klimaatverandering, (nutriënt)vervuiling, en waterbeheer. Aan de hand van abiotische drukfactoren – met name in de vorm van temperatuur, eutrofiëring, en verzilting, worden de ontwikkeling en overleving van onvolwassen muggen beïnvloedt. De effecten per drukfactor zijn uitvoerig beschreven, maar de interacties tussen deze invloeden zijn nog onvoldoende begrepen, hoewel deze vaak samen voorkomen. Om relevante interacties tussen deze geselecteerde drukfactoren te beoordelen, heb ik een reeks full-factorial mesocosm-experimenten uitgevoerd. Mijn resultaten suggereren dat menselijke invloeden vaak een grote en positieve impact hebben op de ontwikkeling en het overleven van muggenpopulaties. Veel van deze effecten worden versterkt door een interactie met toenemende temperaturen.

Deze thesis toont aan dat de drukfactoren, die vaak gelijktijdig optreden, samen een ander effect hebben dan ieder van de factoren in isolatie. Dit benadrukt het belang van het overwegen van hun interacties. De drukfactoren en hun interacties haken hierbij aan op basale processen die spelen bij verschillende muggensoorten, maar met mogelijk verschillende relatieve belangrijkheid. Om deze reden zouden dergelijke interacties standaard meegenomen moeten worden in vector-ecologisch onderzoek. Dit biedt een basis voor de ecologische complexiteit die nodig is om bevindingen uit de experimenten te vertalen naar ecosystemen.

Voor ecologisch realisme is het onvoldoende om alleen rekening te houden met ecologische complexiteit. Het is ook belangrijk om drukfactoren realistisch toe te dienen (door natuurlijke fluctuaties mee te nemen), de context van testpopulaties te overwegen, en synergiën met mitigatie strategieën te beschouwen. De onderstaande tekst onderzoekt deze thema's aan de hand van geselecteerde drukfactoren.

### **In the heat of the moment**

Temperatuur wordt algemeen erkend als een van de belangrijkste invloeden op koudbloedigen. Er zijn dan ook talrijke experimenten met temperatuureffecten voor vectorsoorten uitgevoerd. Het merendeel hiervan vond plaats onder constante temperaturen, terwijl temperaturen in de natuur dagelijkse schommelingen vertonen, wat het metabolisme via (sub)cellulaire processen beïnvloedt. In dit proefschrift test ik een goedkope en simpele methode om de impact van temperatuurschommelingen in mesocosm-experimenten te bestuderen. Door de veelgebruikte constante temperaturen en blokregimes te vergelijken met de gesimuleerde temperatuurschommeling van een gemiddelde dag in juni, laat ik zien dat fluctuaties in temperatuur de ontwikkelingstijd aanzienlijk verkorten vergeleken met constante temperaturen. Het grootste deel van dit verschil treedt op tijdens de metamorfose van pop naar adult, wanneer de muggen niet eten en het minst interageren met hun omgeving.

Het meenemen van natuurlijke temperatuurschommelingen maakt het mogelijk om de invloed van drukfactoren, en hun relatieve belangrijkheid nauwkeuriger te beoordelen. Dit kan belangrijke implicaties hebben voor de voorspelling van grootschalige verstoringen zoals klimaatverandering.

### **Taking it with a grain of salt**

Verzilting is een cruciale drukfactor in zoetwaterecosystemen, bekend om de negatieve impact op biodiversiteit en ecosysteemdiensten. Er wordt algemeen aangenomen dat het belang van deze factor toe zal nemen door zeespiegelstijging, bodemdaling, en zoetwateronttrekking. Toch is er weinig bekend over de directe en indirecte effecten op populaties die onder overgangsomstandigheden leven. Fysiologische- en gedragsaanpassingen in muggen uiten zich in soortspecifieke toleranties, waarbij *Cx. pipiens* wordt beschouwd als intolerant. Toch kan geleidelijke blootstelling, in combinatie met relatief korte generatietijden, lokale aanpassing hebben gestimuleerd. Om te beoordelen of de huismug zich heeft aangepast aan verzilting, heb ik de tolerantie van drie populaties langs een kust-naar-land-gradiënt gekwantificeerd en vergeleken, met de verwachting dat tolerantie aan de kust is verbeterd. De sterfte was aanzienlijk lager dan verwacht bij de (huidig beschreven) maximum lethale dosis (LD100) en de impact op de ontwikkelingssnelheid was verwaarloosbaar. Zouttolerantie was het hoogst in de kust- en binnenlandse populaties, met een aanzienlijk lagere tolerantie voor de tussenliggende populatie.

Deze variaties in tolerantie kunnen gedeeltelijk worden toegeschreven aan de geografische oorsprong en de daaruit volgende historische context van de geteste populaties. Dit benadrukt de noodzaak om rekening te houden met de context van de populatie die in experimenten wordt gebruikt, en om de geografische oorsprong van de gebruikte populaties te communiceren en te contextualiseren.

### **Clashing in murky waters**

Er is in toenemende mate interesse in One Health-strategieën, zoals natuurlijke predatie, om door muggen overgedragen ziekten te bestrijden, terwijl biodiversiteit wijdverspreid afneemt. Dit laatste hoofdstuk van mijn thesis evalueert de effectiviteit van predatoren tegen *Cx. pipiens*. We vergeleken twee Europese amfibieën, de kleine watersalamander (*Lissotriton vulgaris*) en de middelste groene kikker (*Pelophylax kl. esculentus*) met twee veelvoorkomende ongewervelden, de gewone snelzwemmer (*Agabus bipustulatus*) en het gewone bootsmannetje (*Notonecta glauca*). De amfibieën consumeerden 4-8 keer meer muggenlarven dan de onderzochte ongewervelden, zonder verschillen tussen de amfibiesoort, het geslacht, en de verschillende eutrofieringsniveaus. Bovendien zorgde de aanwezigheid van predatoren voor sterke ontmoediging van muggen om hun eieren te leggen. Dit suggereert de aanwezigheid van een landscape of fear, ofwel de ruimtelijke beoordeling van predatiedruk door een prooi.

Deze bevindingen benadrukken het potentieel van amfibieën als natuurlijke muggenbestrijdingsmethode, zowel door het beperken van overleving als door kolonisatie geheel te voorkomen. Dit accentueert het belang van het behoud van deze bedreigde soorten in zowel stedelijke als landelijke gebieden.

### **Slotopmerkingen**

In dit proefschrift heb ik een overzicht gegeven van de belangrijkste menselijke drukfactoren, hun interacties, en gevolgen, op de populatiedynamiek van *Cx. pipiens*. Zoals u hebt kunnen lezen zijn deze effecten aanzienlijk en kunnen ze elkaar versterken. In mijn studies heb ik laten zien hoe het mogelijk is om tot nauwkeurige en relevante resultaten te komen, die verder reiken dan strict gecontroleerde experimentele omstandigheden. Daarmee benadrukt dit werk de noodzaak om ecologische realisme zoveel mogelijk te integreren in experimenteel ecologische studies, wat met name van groot belang is binnen het kader van One Health, waar interacties de norm zijn.

Ook biedt dit werk een grondslag voor voorspellingen over veranderingen in muggenpopulaties in een veranderende wereld. Dit vergroot ons begrip van de drukfactoren waarop effectieve interventies zich moeten richten. Op deze manier vormt deze thesis een basis voor het anticiperen op en verminderen van het risico op door *Culex*-overdraagbare ziekten.



Acknowledgements

## **Acknowledgements**

## Acknowledgements

---

Completing this thesis has been as transformative for me as it was for the tens of thousands of mosquitoes that emerged in my experiments. This journey would not have been possible without the unwavering support of many, to whom I dedicate this section.

First and foremost, I would like to thank my promotor, Prof. Peter van Bodegom, whose guidance and expertise have been invaluable. Peter, thank you for your patience and trust. I am equally grateful to my co-promotors Eline Boelee and Maarten Schrama, whose encouragement, experience and enthusiasm helped me to grow academically and personally. Eline, thank you for your undivided attention and for always going the extra mile. Maarten, thank you for your dedication and the in-depth discussions. You three have truly shaped this thesis, and in the occurrence that any mistakes have made it through their elaborate proofreading, please blame Maarten, as he should have taught me better.

I am also grateful to the thesis reading committee, Prof. Dr. Ing. M.G. Vijver, Prof. Dr. K. Biesmeijer, Prof. Dr. F. Bartumeus Ferré, Prof. Dr. Q.A. ten Bosch, and Dr. M. Braks. Thank you for your time, and critical insights on my thesis. Your evaluations have been encouraging during these last few steps.

To my colleagues within WP4, Louie Krol, Martha Dellar, Gertjan Geerling, and Floris Neijns, I thank you for your collaboration, dedication, and the comradery. Working alongside such committed peers in the OHPACT, including Emmanuelle Münger, Kiki Streng, Rody Blom, Charlotte Linthout and Ayat Abourashed, was a privilege. Special thanks go to other collaborators, Anniek de Jong, Annemarieke and Jeroen Spitzen and Roderick Bouman, for your expertise and efforts that helped in performing, writing and publishing this research.

This thesis would not have been possible without the dedication of my students, among whom some I am privileged to now call friends. Anne, Sterre, Karsten, Surendra, Jordy, Noor, Roderick, Erin, Lisa, Antje, Joris, and Julia. It was your interest that kept me motivated. To Tom Nederstigt and Martin van der Plas, as well as countless students, colleagues, friends, friends of students and friends of friends that volunteered during sampling. Thank you and I will not forget your help.

Within the CML, I was fortunate to work with so many inspiring colleagues. Krijn Trimbos, Emily Strange, and Henrik Barmentlo, the discussions and occasional side-experiments were a breath of fresh air during the longer projects. I hope we continue to collaborate. To my contemporaries Kevin Groen, Tom Nederstigt, Emily Didaskalou, Evelien Castrop, Bregje Brinkmann, Bertram de Boer, Sofie Rasmussen, Laura Zantis, Lan Dupuis, and Joeri Morpurgo. I'm glad to have spent my time at the CML with you. I will miss our random conversations, laughs and drinks. To the supporting staff — particularly Milan Oostwouder, Sammy Koning, Bo Bode, and Kornelia Serwatowska — your behind-the-scenes support is not forgotten. You have been crucial to me navigating the (occasionally) obtuse procedures of Leiden University. To those that I did not mention yet, forgive me, and thank you all sincerely.

I would also like to acknowledge my friends and colleagues at Deltares, particularly Tarek Jaber, Yuxiao He, Franco Forlano Bo, Hao Wang and those in the EWQ group, for welcoming me during the finalization of this thesis. Your enthusiasm, commitment and expertise are contagious and provide perspective for what I hope to work towards.

To my inner circle — Sanne de Jong, Lianne Oosterhoud, Niels van der Windt, Kevin Haasnoot, and Jelle Oskam — your support has been invaluable throughout this journey. So much has happened during these years and I am thankful for your sympathy, attention and friendship that got me through these times. To the nerds in my D&D group, including Simon Otto, David van Dijk, and Dax Godding, as well as others mentioned elsewhere, thank you for our (years of) adventures. Although the majority of my prep work was for naught, I wouldn't want to trade it for the time we had.

Amy Montanje and Lois van Laere, thank you for your friendship, commitment and creativity to enable our controlled out of control charity projects at Save that Ass. I hope there will be many to follow. To my friends Dionne Jacobs, Iris Noordermeer, Jelle Dercksen, Colin Meulblok, and Charlotte Kampert, thank you for our impromptu gatherings and discussions.

Ten slotte bedank ik mijn familie – Tim, Ona en Ramon Boerlijst – voor hun steun en enthousiasme tijdens de afgelopen jaren. Jullie liefde en vertrouwen zijn een constante bron van motivatie. Dit geldt ook voor mijn inmiddels overleden grootouders Emile en Mieke Lyon, waar ik al jaren met hetzelfde krantenknipsel

## Acknowledgements

---

'vandaag' in de krant stond. Ik hoop iemand te zijn waarnaar jullie op kunnen kijken. Daniel Ganzor, Toos van Peuzelen, en Carel Kluyvert, ook jullie aanmoediging en steun zal ik niet vergeten. Bewust of onbewust hebben jullie allemaal bijgedragen aan dit proefschrift.





Curriculum vitae and publications

## **Curriculum vitae and publications**

## Curriculum vitae

---

Sam Philip Boerlijst was born on the fourteenth of July, 1995 in De Haan, Belgium. After completing his havo and thereafter vwo at the KSH of Hoofddorp in 2012, he started studying Biology at the University of Leiden. During his bachelors, he performed a scientific internship at the CML of Leiden University into the spatiotemporal distribution of eDNA for the invertebrate species *Pomacea diffusa* (Gastropoda: Ampullariidae) and *Neocaridina davidi* (Decapoda: Atyidae) under supervision of dr. Krijn Trimbos (CML). After successfully completing his BSc, he then started his MSc. Biodiversity & Sustainability in 2017. During his masters, he performed two scientific internships. The first internship concerned the development of eDNA-based molecular detection methods for Culicids in the Dutch Caribbean at Naturalis Biodiversity Centre under supervision of dr. Maarten Schrama. (CML/Naturalis) His second internship at the CML of Leiden University focused on development of a genotyping protocol complementing dietary analyses of the African lion (Carnivora: Felidae) under supervision of dr. Krijn Trimbos (CML). The successful completion of his courses and internships led to a Cum Laude (with distinction) MSc. degree in 2019.

In 2020, Sam started his PhD research into the effects of anthropogenic impacts on the population dynamics of the brown house mosquito at Leiden University, supervised by prof. dr. ir Peter van Bodegom (CML), dr. Maarten Schrama (CML) and dr. Eline Boelee (Deltares), resulting in this thesis. Sam's research was conducted as part of the One Health Predicting Arboviruses Climate Tipping points (OHPACT) project (<https://www.onehealthpact.org/>).

Sam presented his work at the NEV Nationale Entomologendag in Wageningen (the Netherlands, 2021), the 22nd European Society of Vector Ecology Conference in Sofia (Bulgaria 2022) and the Urban Spaces and Mosquitoes on a Changing Planet Conference in Barcelona (Spain, 2023). In addition, Sam's work was featured in news outlets including de Volkskrant, DeltaFact, Hortus Leiden, Leidsch Dagblad, Mare, NRC, het Parool and radio show Sleutelstad.

During his PhD research, Sam developed several open-source software and hardware projects to further ecological research, including weatherstations, thermoregulators and a Python library for automated tagging and selection of research papers. In addition, he published several manuscripts, gave public lectures and workshops and supervised a total of 12 students during their internships. Sam lectured in various courses (BSc. and MSc. level) on the topics of environmental biology, ecological field research, systems ecology and vector ecology. He also co-

founded the foundation *Save That Ass*, to support and facilitate nature education, with which he published the satirical identification guide “A Pocket Guide to Animal Asses of East Africa“, for charity. With this publication, he won CML its Stans Award 2020 for public outreach.

In May 2024, he started his position as medior researcher and advisor aquatic ecology at Deltares to investigate anthropogenic impacts on water quality and water & health.

---

**Publications (peer-reviewed)**

**Boerlijst, S. P.**, Ummels, A., Spitzen-van der Sluijs, A. M., Spitzen, J., Bouman, R.W., Boelee, E., van Bodegom, P.M. & Schrama, M. (2024). Clashing in murky waters: on amphibian mosquito suppression. *Journal of Animal Ecology*, in press.

**Boerlijst, S. P.**, van der Gaast, A., Adema, L. M. W., Bouman, R. W., Boelee, E., van Bodegom, P. M. & Schrama, M. (2024). Taking it with a grain of salt: tolerance to increasing salinization in *Culex pipiens* (Diptera: Culicidae) across a low-lying delta. *Parasites & Vectors*. <https://doi.org/10.1186/s13071-024-06268-8>

**Boerlijst, S. P.**, Boelee, E., van Bodegom, P. M. & Schrama, M. (2024). In the heat of the moment: including realistic thermal fluctuations using an open-source thermoregulator results in dramatically altered key population parameters. *Methods in Ecology & Evolution*. <https://doi.org/10.1002/ece3.70124>

**Boerlijst, S. P.**, Johnston, E. S., Ummels, A., Krol, L., Boelee, E., van Bodegom, P. M., & Schrama, M. J. J. (2023). Biting the hand that feeds: Anthropogenic drivers interactively make mosquitoes thrive. *Science of The Total Environment*, 858, 159716. <https://doi.org/10.1016/j.scitotenv.2022.159716>

Dellar, M., **Boerlijst, S. P.**, & Holmes, D. (2022). Improving estimations of life history parameters of small animals in mesocosm experiments: A case study on mosquitoes. *Methods in Ecology and Evolution*, 2041-210X.13814.<https://doi.org/10.1111/2041-210X.13814>

Makiola, A., Compson, Z. G., Baird, D. J., Barnes, M. A., **Boerlijst, S. P.**, Bouchez, A., Brennan, G., Bush, A., Canard, E., Cordier, T., Creer, S., Curry, R. A., David, P., Dumbrell, A. J., Gravel, D., Hajibabaei, M., Hayden, B., Van Der Hoorn, B., Jarne, P., ... Bohan, D. A. (2020). Key Questions for Next-Generation Biomonitoring. *Frontiers in Environmental Science*, 7, 197. <https://doi.org/10.3389/fenvs.2019.00197>

(Continued on next page)

## Publications

---

Van Der Beek, J. G., Dijkstra, K.-D. B., Van Der Hoorn, B. B., **Boerlijst, S. P.**, Busscher, L., Kok, M. L., Braks, M. A. H., Schaffner, F., Davelaar, G. J., Henry, M., Hulshof, K., Leslie, T. E., & Schrama, M. (2020). Taxonomy, ecology and distribution of the mosquitoes (Diptera: Culicidae) of the Dutch Leeward Islands, with a key to the adults and fourth instar larvae. *Contributions to Zoology*, 89(4), 373–392. <https://doi.org/10.1163/18759866-bja10005>

**Boerlijst, S. P.**, Trimbos, K. B., Van der Beek, J. G., Dijkstra, K. D. B., Van der Hoorn, B. B., & Schrama, M. (2019). Field Evaluation of DNA Based Biodiversity Monitoring of Caribbean Mosquitoes. *Frontiers in Ecology and Evolution*, 7, 240. <https://doi.org/10.3389/fevo.2019.00240>

## Abstracts

**Boerlijst S. P.**, Boelee, E., van Bodegom, P. M. & Schrama, M. (2023). An egg is always an adventure: anthropogenic effects on ovipositioning behavior. Urban Spaces and Mosquitoes on a Changing Planet Conference. Barcelona, Spain. 23-25 March 2023. (Oral presentation)

**Boerlijst S. P.**, Boelee, E., van Bodegom, P. M. & Schrama, M. (2022). In the heat of the moment: temperature fluctuations promote mosquito development. European SOVE 22nd conference. Sofia, Bulgaria. 11-14 October 2022. (Poster presentation)

**Boerlijst S. P.**, Boelee, E., van Bodegom, P. M. & Schrama, M. (2021). Human impacts on *Culex pipiens* population dynamics. 33e entomologendag. Ede-Wagenignen, The Netherlands. 17 December 2021. (Oral presentation)

---

## Software

Sam Boerlijst. (2024). SamBoerlijst/HIHI: MEE HIHI V1.00 (v1.0.0). Zenodo. <https://doi.org/10.5281/zenodo.10724530>

Sam Boerlijst. (2023). SamBoerlijst/WHIMSY: v0.2.5-alpha (v0.2.5-alpha). Zenodo. <https://doi.org/10.5281/zenodo.7924736>

Sam Boerlijst. (2023). SamBoerlijst/aparts: 0.0.20 (0.0.2). Zenodo. <https://zenodo.org/doi/10.5281/zenodo.7916306>

## Other

Chantal Reusken, Marieta Braks, e.a. (2022). De Mug. Over steekmuggen en de verspreiding van ziekten. ISBN: 9789088031151.

Montanje, A.E., Boerlijst, S. P. e.a, (2020). A pocket guide to Animal Asses of East Africa. An asstounding reference book to East African Wildlife. ISBN: 9789082995725

