



Universiteit
Leiden
The Netherlands

Heterogeneity in RAG1 and RAG2 deficiency: 35 cases from a single-centre

Karaatmaca, B.; Cagdas, D.; Esenboga, S.; Erman, B.; Tan, C.G.; Ozgur, T.T.; ... ; Tezcan, I.

Citation

Karaatmaca, B., Cagdas, D., Esenboga, S., Erman, B., Tan, C. G., Ozgur, T. T., ... Tezcan, I. (2023). Heterogeneity in RAG1 and RAG2 deficiency: 35 cases from a single-centre. *Clinical & Experimental Immunology*, 215(2), 160-176. doi:10.1093/cei/uxad110

Version: Publisher's Version

License: [Creative Commons CC BY 4.0 license](https://creativecommons.org/licenses/by/4.0/)

Downloaded from: <https://hdl.handle.net/1887/3762557>

Note: To cite this publication please use the final published version (if applicable).



Research Article

Heterogeneity in RAG1 and RAG2 deficiency: 35 cases from a single-centre

Betul Karaatmaca^{1,2,*} , Deniz Cagdas^{1,3,*} , Saliha Esenboga¹, Baran Erman³, Cagman Tan³, Tuba Turul Ozgur¹, Kaan Boztug^{4,5,6,7,8}, Mirjam van der Burg⁹, Ozden Sanal¹ and Ilhan Tezcan^{1,3}

¹Hacettepe University School of Medicine, Department of Pediatrics, Division of Pediatric Immunology, Ankara, Turkey

²Department of Pediatric Allergy and Immunology, University of Health Sciences, Ankara Bilkent City Hospital, Ankara, Turkey

³Section of Pediatric Immunology, Institute of Child Health, Hacettepe University, Ankara, Turkey

⁴St. Anna Children's Cancer Research Institute (CCRI), Vienna, Austria

⁵CeMM Research Center for Molecular Medicine of the Austrian Academy of Sciences, Vienna, Austria

⁶Medical University of Vienna, Department of Pediatrics and Adolescent Medicine, Vienna, Austria

⁷Ludwig Boltzmann Institute for Rare and Undiagnosed Diseases, Vienna, Austria

⁸St. Anna Children's Hospital, Vienna, Austria

⁹Department of Pediatrics, Laboratory for Pediatric Immunology, Willem-Alexander Children's Hospital, Leiden University Medical Center, Leiden, The Netherlands

*These authors have contributed equally, and are designated to have co-first authorship.

Correspondence: Deniz Cagdas, Hacettepe University Medical School, İhsan Doğramacı Children's Hospital, Institute of Child Health, Department of Pediatrics, Section of Pediatric Immunology, Altındağ, Ankara, Turkey. Email: deniz.ayvaz@hacettepe.edu.tr

Abstract

Recombination activating genes (RAG)1 and RAG2 deficiency leads to combined T/B-cell deficiency with varying clinical presentations. This study aimed to define the clinical/laboratory spectrum of RAG1 and RAG2 deficiency. We retrospectively reviewed the clinical/laboratory data of 35 patients, grouped them as severe combined immunodeficiency (SCID), Omenn syndrome (OS), and delayed-onset combined immunodeficiency (CID) and reported nine novel mutations. The male/female ratio was 23/12. Median age of clinical manifestations was 1 months (mo) (0.5–2), 2 mo (1.25–5), and 14 mo (3.63–27), age at diagnosis was 4 mo (3–6), 4.5 mo (2.5–9.75), and 27 mo (14.5–70) in SCID ($n = 25$; 71.4%), OS ($n = 5$; 14.3%), and CID ($n = 5$; 14.3%) patients, respectively. Common clinical manifestations were recurrent sinopulmonary infections 82.9%, oral moniliasis 62.9%, diarrhea 51.4%, and eczema/dermatitis 42.9%. Autoimmune features were present in 31.4% of the patients; 80% were in CID patients. Lymphopenia was present in 92% of SCID, 80% of OS, and 80% of CID patients. All SCID and CID patients had low T (CD3, CD4, and CD8), low B, and increased NK cell numbers. Twenty-eight patients underwent hematopoietic stem cell transplantation (HSCT), whereas seven patients died before HSCT. Median age at HSCT was 7 mo (4–13.5). Survival differed in groups; maximum in SCID patients who had an HLA-matched family donor, minimum in OS. Totally 19 (54.3%) patients survived. Early molecular genetic studies will give both individualized therapy options, and a survival advantage because of timely diagnosis and treatment. Further improvement in therapeutic outcomes will be possible if clinicians gain time for HSCT.

Received 6 April 2023; Revised 3 September 2023; Accepted for publication 17 September 2023

© The Author(s) 2023. Published by Oxford University Press on behalf of the British Society for Immunology.

This is an Open Access article distributed under the terms of the Creative Commons Attribution License (<https://creativecommons.org/licenses/by/4.0/>), which permits unrestricted reuse, distribution, and reproduction in any medium, provided the original work is properly cited.

Graphical Abstract

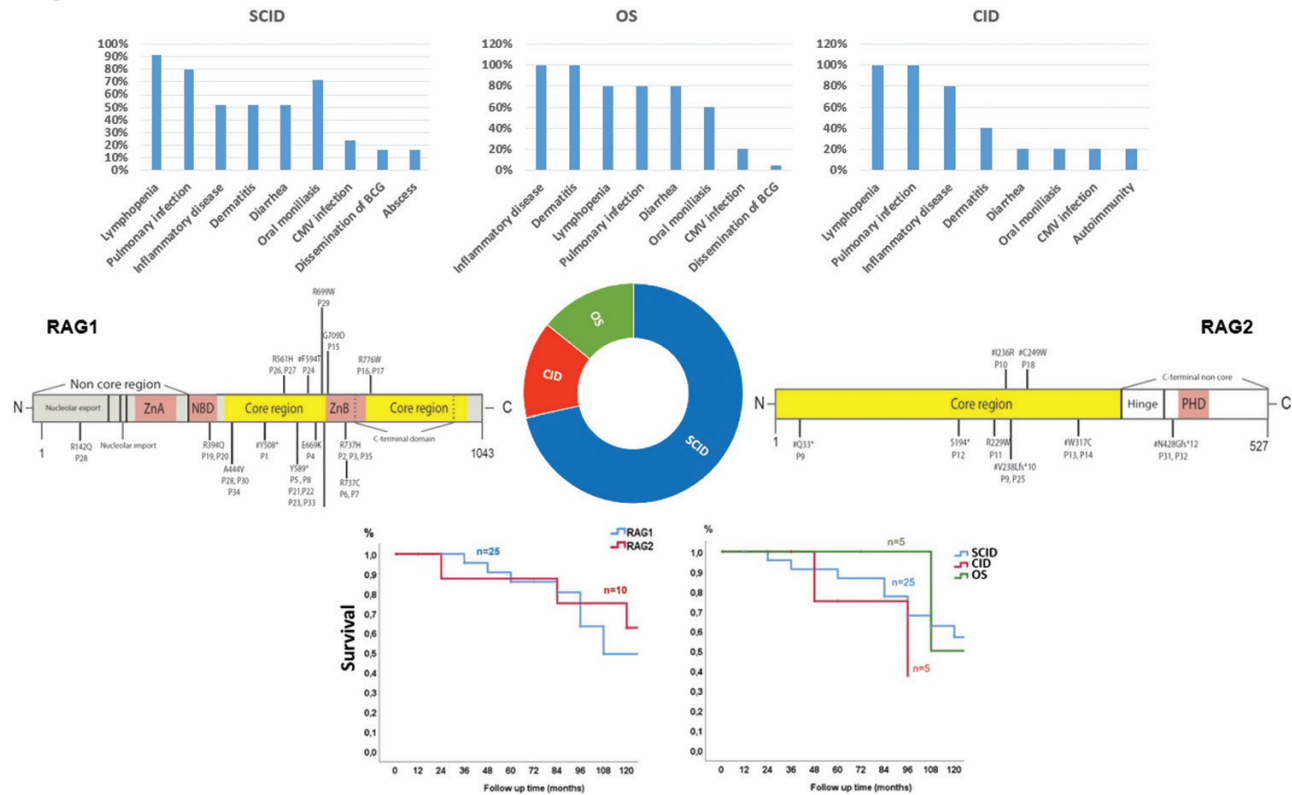

Keywords: autoimmunity, erythroderma, Omenn syndrome, RAG1/2, severe combined immunodeficiency, vasculitis

Abbreviations: AIC: autoimmune cytopenia; AIHA: autoimmune hemolytic anemia; BCG: Bacillus-Calmette-Guérin; CD: cluster of differentiation; CID: combined immunodeficiency; CID-G/AI: combined immunodeficiency with granulomas and/or autoimmunity; CMV: cytomegalovirus; CVID: common variable disease; GVHD: graft versus host disease; HLA: human leukocyte antigen; HSCT: hematopoietic stem cell transplantation; IBD: inflammatory bowel disease; Ig: immunoglobulin; IQR: interquartile ranges; IVIG: intravenous immunoglobulin; ITP: immune thrombocytopenia; MMF: mycophenolate mofetil; NGS: next generation sequencing; NK: natural killer; OS: Omenn syndrome; PID: primary immune deficiency; RAG½: recombination activating gene ½; RSS: recombination signal sequence; SCID: severe combined immunodeficiency.

Introduction

The recombination activating genes (RAG) 1 and 2 have essential roles in the early stage of V(D)J [variable (diversity) joining segments] recombination, which provides the plasticity of the adaptive immune system to give reaction to diverse antigens. Therefore, defect in the V(D)J recombination process leads to a restricted antigen receptor repertoire in the adaptive immune system [1].

Schwarz *et al.* [2] first described RAG gene mutations in patients with T-negative (T⁻), B-negative (B⁻), and natural killer cell-positive (NK⁺) severe combined immunodeficiency (SCID) in 1996. Further studies showed that human RAG gene mutations have a broad spectrum of clinical and immunological phenotypes other than classical SCID [3, 4]. In SCID patients, clinical findings usually begin in the first year of life, generally soon after birth. Life-threatening opportunistic viral and fungal infections are common. Patients experience recurrent sinopulmonary infections, interstitial pneumonitis, protracted diarrhea, and failure to thrive. Lymphopenia and severe hypogammaglobulinemia are frequent findings. Hematopoietic stem cell transplantation (HSCT) should be planned just after the diagnosis of SCID because T- and B-cell reconstitution is curative for SCID [5, 6].

A rare clinical presentation of RAG deficiency is Omenn syndrome (OS). RAG genes have a partial V(D)J recombination activity in OS [1, 7]. Omenn syndrome may result

when certain hypomorphic RAG½ gene mutations result in partial V(D)J recombination activity, and leads to an activated oligoclonal T cell proliferation and infiltration in several organs, especially in skin, gut, and liver. The findings of OS are generalized erythroderma, lymphadenopathy, hepatosplenomegaly, eosinophilia, hypogammaglobulinemia, and high immunoglobulin (Ig) E levels. Clinical follow-up and treatment are similar to SCID [7, 8].

If hypomorphic RAG gene mutations are present, residual RAG protein activity is possible which will cause delayed-onset disease forms and mimic common variable immunodeficiency (CVID) or combined immunodeficiency (CID). In delayed-onset RAG deficiency patients, autoimmune cytopenia (AIC), vasculitis, nephritis, and granulomatous lesions in various tissues and organs are common in addition to recurrent sinopulmonary infections [9, 10]. Idiopathic CD4⁺ T-cell lymphopenia [11], IgA deficiency [12], selective deficiency of polysaccharide-specific antibody responses [13], and hyper-IgM syndrome [14] are other delayed-onset and atypical presentations. Different clinical phenotypes with the same RAG defect even in the same family may support the role of epigenetic factors on the phenotype [1].

Herein, we aimed to elucidate the clinical features, molecular diagnosis, and outcomes of RAG½ deficient patients followed by a tertiary pediatric immunology department over

a twenty-year period by describing the variable clinical presentation.

Material and methods

Patients and study design

This study enrolled 35 RAGD patients from 30 families diagnosed in a twenty-year period (1999–2019) at Hacettepe University, Ihsan Dogramaci Children's Hospital, Division of Pediatric Immunology. We retrospectively noted the clinical and laboratory data from medical records. We recruited the patients into three groups according to the clinical presentations/immunological findings; typical T(-)B(-)NK(+) SCID, OS, and delayed-onset CID (leaky SCID and atypical SCID) [9]. Hacettepe University Institutional Review Board approved the study, and the parents of the patients signed the informed consent.

SCID patients were diagnosed by using the European Society of Immunodeficiency Disorders (ESID) Criteria [15] and International Union of Immunological Societies (IUIS) guidelines [16]. OS criteria included the presence of erythroderma or atopic/seborrheic dermatitis in the absence of maternal engraftment [7, 17]. Delayed-onset patients with RAG $\frac{1}{2}$ mutations were diagnosed with delayed-onset CID, depending on the clinical symptoms and laboratory data [9].

The demographic characteristics of the patients (age of manifestation, age at diagnosis, gender, family history, etc.), clinical and laboratory findings, genetic mutations, HSCT outcomes, and survival were evaluated. RAG deficient patients those with high CD3 count, and high CD45RO value were assessed in terms of maternal engraftment, and karyotype and chimerism analyses were performed.

Flow cytometry

We performed the analysis of peripheral blood lymphocyte populations by one laser three-color flow cytometry (BD Biosciences FACS Calibur, USA). One-hundred microliter of whole blood was obtained and stained with 20 μ l of the monoclonal antibodies (CD3(fluorescein isothiocyanate (FITC)), CD4(FITC), CD8 (peridinin-chlorophyll protein complex (PerCP)), CD16 + 56(APC), and CD19 (phycoerythrin (PE)) (Beckton Dickinson, BD, USA)). Then, the samples were incubated in the dark for 15 min at room temperature.

Sanger sequencing

DNA was isolated from peripheral blood mononuclear cells after separation using Ficoll-Paque (GE Healthcare, Little Chalfont, UK) according to the manufacturer's instructions. Sequence analysis of RAG $\frac{1}{2}$ was performed following PCR amplification of the coding regions with TaqGoldTM (Life Technologies), followed by direct sequencing on an ABI Prism 3130 XL fluorescent sequencer (Applied Biosystems, Bleiswijk, the Netherlands).

Targeted primary immunodeficiency panel screening

The molecular analyses of the patients were performed in the Hacettepe Pediatric Immunology Laboratory [18], Erasmus Center, and CeMM Research Center by using next-generation sequencing (NGS) for primary immune deficiency (PID) [19] and the Sanger Technique.

Statistical analysis

Statistical analysis was performed by using SPSS® version 22.0 for Windows (IBM SPSS, Chicago, IL, USA). Quantitative parameters were reported as means and SD, or as medians with 25th and 75th percentile values in case of skewed distribution. Categorical variables were described using absolute frequencies and proportions with a 95% CI. A *P*-value of <0.05 was considered statistically significant. Kaplan–Meier test was used for survival analysis.

Results

Patient characteristics

Thirty-five RAG-deficient patients (65.7% male) were included in the study. Eighty percent of cases had parental consanguinity, and 57.1% of the cases had a history of immunodeficiency in siblings or other family members. We subdivided the patients into three groups considering the clinical presentations and immunological findings: typical SCID (patients P1–25); OS (P26–30), and delayed-onset CID (P31–35) [9, 15, 16].

RAG $\frac{1}{2}$ mutations and affected domains

Twenty-five patients had RAG1, and 10 patients had RAG2 deficiency. The RAG $\frac{1}{2}$ mutations, and affected RAG $\frac{1}{2}$ domains are shown in Table 1 and Fig. 1A and B. Mutations were mostly found in the core region for RAG1 and RAG2 genes. P26 and P27 were cousins, and had novel RAG2 mutations affecting the C-terminal non-core domain.

All patients with RAG1 and RAG2 deficiency had homozygous mutations, except three patients (RAG 1 deficient P19 and P33 and RAG2 deficient P9) had compound heterozygous mutations. Among the thirty-five patients included in this study, three in the RAG1 gene and six in the RAG2 gene, a totally of nine novel mutations were reported and depicted in Table 1 and Fig. 1A and B. P33 and P34 were previously reported [25, 27].

Clinical manifestations

Common clinical manifestations were recurrent sinopulmonary infections 82.9%, oral moniliasis 62.9%, eczema/dermatitis 42.9%, diarrhea 51.4%, and autoimmunity 31.4% (Table 2 and Fig. 2).

Autoimmune/inflammatory findings

Autoimmunity was recorded in 11 patients (31.4%); alopecia (*n* = 4), vitiligo (*n* = 2), granulomatous skin lesions and IBD (*n* = 1), vasculitis (*n* = 1), progressive neuropathy (*n* = 1), and AIC [AIHA (autoimmune hemolytic anemia), ITP (immune thrombocytopenia)] (*n* = 2, SCID patients post-HSCT). The ratio of AIC was 2/35 (6%) in RAG $\frac{1}{2}$ deficiency in this cohort.

Almost all autoimmune findings were generally associated with the CID group, albeit a patient with vitiligo was in the SCID group and patients with alopecia were in the OS group. (Table 2). Inflammatory disorders including hepatomegaly and/or splenomegaly, lymphadenopathy and several forms of dermatitis were quite common in all groups (Table 2/Fig. 2).

Infectious diseases

CMV infection developed in 8/35 patients (SCID = 6, CID = 1, and OS = 1), and in two SCID patients (P11 and P20) retinitis developed as a complication. Immune thrombocytopenic

Table 1. The analysis of the RAG mutations in our cohort

Patients	Gene	Variant	AA change	Variant type	Zygoty	Phenotype	Novelty (reference number)
P1	RAG1	c.1524T > C	Y508*	Nonsense	Hom	SCID	Yes
P2, P3, and P30	RAG1	c.2322G > A	R737H	Missense	Hom	SCID and OS	No [7]
P4	RAG1	c.2005G > A	E669K	Missense	Hom	SCID	No [20]
P5, P8, P21, P22, P23, and P28	RAG1	c.1879C > G	Y589*	Nonsense	Hom	SCID and OS	No [17]
P6 and P7	RAG1	c.2322C > T	R737C	Missense	Hom	SCID	No [21]
P9	RAG2	c.217C > T/c.712delG	Q33*/V238Lfs*10	Nonsense/Del. Frameshift	Comp. het.	SCID	Yes
P10	RAG2	c.707T > G	I236R	Missense	Hom	SCID	Yes
P11	RAG2	c.1886C > T	R229W	Nonsense	Hom	SCID	No [2]
P12	RAG2	c.1782C > A	S194*	Missense	Hom	SCID	No [21]
P13 and P14	RAG2	c.951G > T	W317C	Missense	Hom	SCID	Yes
P15	RAG1	c.2126G > A	G709D	Missense	Hom	SCID	No [22]
P16 and P17	RAG1	c.2326C > T	R776W	Missense	Hom	SCID	No [23]
P18	RAG2	c.746 G > A	C249W	Missense	Hom	SCID	Yes
P19	RAG1	c.1181G > A/c.2116delA	R394Q/R706Gfs*44	Missense/del. frameshift	Comp. het.	SCID	No [24]/Yes
P20	RAG1	c.1181G > A	R394Q	Missense	Hom	SCID	No [24]
P24	RAG1	c.1780_1781 delTTinsAC	F594T	Indel	Hom	SCID	Yes
P25	RAG2	c.712delG	V238Lfs*10	Del. frameshift	Hom	SCID	Yes
P26 and P27	RAG2	c.1280_1281insTGGATAT	N428Gfs*12	Ins. frameshift	Hom	OS	Yes
P29 and P35	RAG1	c.1331C > T	A444V	Missense	Hom	OS and CID	No [17]
P31 and P32	RAG1	c.1682G > A	R561H	Missense	Hom	CID	No [7]
P33	RAG1	c.537G > A/c.1443C > T	R142Q/A444V	Missense/Missense	Comp. het.	CID	No [25]/No [17]
P34	RAG1	c.2095C > T	R699W	Missense	Hom	CID	No [26]

AA: amino acid; *: stop codon, Hom: homozygous; Comp. het: compound heterozygous; Del: deletion; Ins: insertion.

purpura associated with CMV infection developed in P11 at the age of 1.5 mo [2]. Foscarnet and ganciclovir were given. After referral, she was diagnosed with SCID and treated with HSCT successfully. The other SCID patient developed CMV retinitis during the disease course and underwent HSCT. Despite ganciclovir and CMV hyperimmunoglobulin, blindness developed.

Warts occurred in two siblings in the CID group (P31 and P32); the lesions were resistant to cryotherapy and laser in one. They had a previously reported RAG1 mutation (R561H; c.1682 G > A) [7].

Bacillus-Calmette-Guérin (BCG) is a live-attenuated vaccine and is contraindicated in SCID patients. Unfortunately, it is administered soon after birth since tuberculosis is still a public health problem in some countries [28]. BCG is in the national vaccination schedule, and applied at the age of 2 mo in Turkey. As the median (IQR) age at diagnosis was 5 (3–10) mo in our cohort, 23 out of 35 patients received BCG vaccine before the diagnosis of PID. All BCG-vaccinated patients received isoniazid (INH) and rifampicin (RIF) for tuberculosis prophylaxis. Four SCID patients (P5, P7, P9, and P21) were diagnosed with BCGitis after HSCT and treated with additional anti-mycobacterial drugs.

Laboratory findings

Lymphopenia (88.6%) was the most common laboratory finding (Table 3 [9, 29]), present in 92% of SCID patients

(P1–25), 80% of OS (P26–30) patients, and 80% of CID (P31–35) patients. The definition of lymphopenia and the normal ranges of lymphocyte subsets used in this manuscript was based on the study of Shearer et al. [29].

Fifty-two percent of SCID patients, 80% of OS patients, and 20% of CID patients had low IgA, IgG, and IgM on admission. Normal/high IgG levels in some of the SCID patients were attributed to partially transplacental IgG transfer from their mothers. Most of the patients especially in the OS group had profound hypogammaglobulinemia on the first visit. Laboratory findings of RAG-deficient patients are summarized in Table 3.

Classification of patients with RAG^{1/2} deficiency

Typical severe CID patients

Twenty-five patients, 19 males and 6 females were diagnosed with typical T(–) B(–) NK(+) SCID (patients [P] 1–25). The median age of clinical manifestations was 1 (0.5–2) mo and the age at diagnosis was 4 (3–6) mo. The parental consanguinity ratios were 15/17 and 5/8 in patients with RAG1 and RAG2 deficiency, respectively. Early onset of life-threatening infections and lymphopenia were common findings in SCID patients. Almost all patients except P1 and P11 [2] had lymphopenia [29]. Eczema and diaper dermatitis were also common. Clinical and laboratory characteristics are given in Tables 2 and 3.

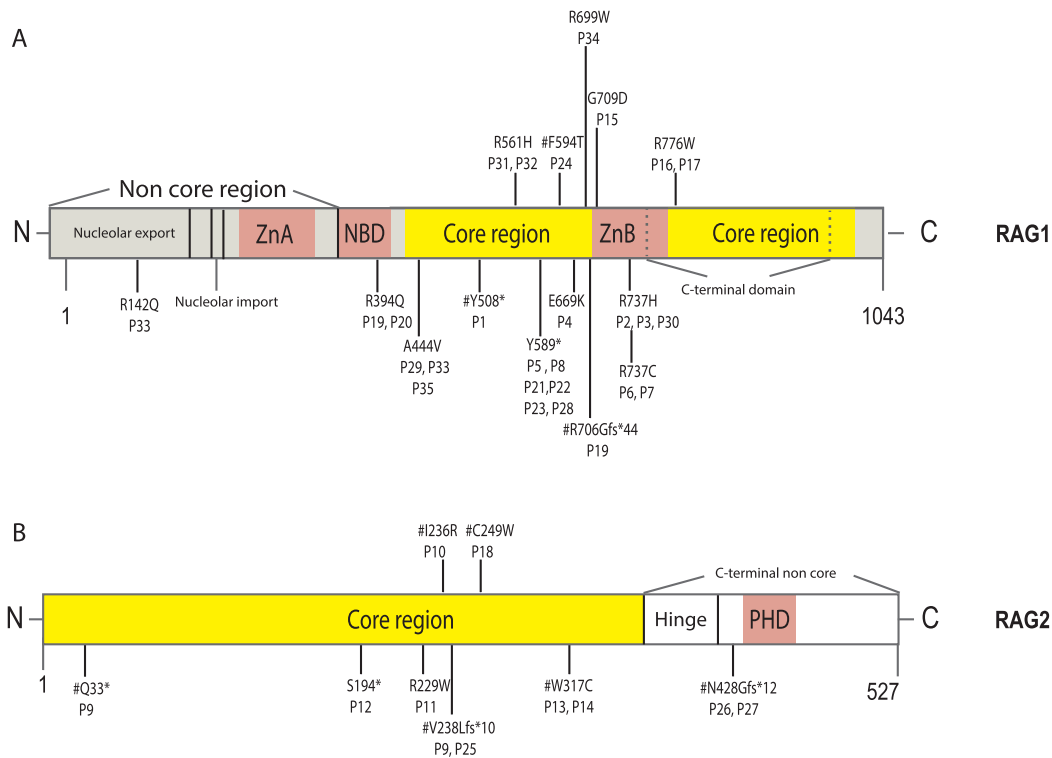

Figure 1. A-B. Mutations and affected RAG 1 and 2 domains in the patients. #: novel mutations. NBD: nanomer binding domain; PHD domain: the plant homeodomain; ZnA: zinc finger A; ZnB: zinc finger B

OS patients

Five female patients were diagnosed with OS (P26–P30). P26 and P27 were cousins and had novel RAG2 mutations. The median age of clinical manifestations was 2 (1.25–5) mo, and the age at diagnosis was 4.5 (2.5–9.75) mo. All except one OS patient were born to consanguineous parents (P27's parents were from the same village). Dermatitis was a common finding in all OS patients. Diffuse erythroderma, exfoliative dermatitis, and diffuse seborrheic dermatitis were present sometimes with alopecia and nail dystrophy. They had very low B-cell counts. Eosinophilia was present in 3/5. Only one patient P28 had elevated IgE [17].

Delayed-onset CID patients

In this cohort, the ratio of hypomorphic defects was 5/35 (14.3%). All (P31–P35) were RAG1 deficiency patients with delayed-onset (CID). The median age of clinical manifestations was 14 (3.63–27) mo, and the median age at diagnosis was 27 (14.5–70) mo. The male/female ratio was 4/1. P31 and P32 were siblings presented with recurrent sinopulmonary infections and widespread warts [7]. P33 had skin granuloma, and protracted diarrhea, mimicking inflammatory bowel disease (IBD) [25]. P34 had isolated CD4 deficiency when he was admitted with hemoptysis and dyspnea due to pulmonary hemorrhage. He was diagnosed with polyarteritis nodosa (PAN) [26, 27]. Hemoptysis recurred, and Coombs (+) AIHA developed at 18 mo of age. Despite immunosuppressives (steroids, cyclophosphamide, and azathioprine) and supportive treatments, vasculitis deteriorated, digital necrosis, and autoamputation developed. P35 was admitted with recurrent sinopulmonary infections and gingival hypertrophy at the age of 1.5 years [17]. Ataxia and progressive neurological deterioration developed when he was 25 mo old.

Survival and outcome

Twenty-eight patients (80%) (SCID; 22, OS; 2, and CID; 4) underwent HSCT. Nineteen had an HLA-matched family donor, five had haploidentical (parent) donors, and four patients had a matched unrelated donor (MUD) (Table 4). Eleven out of 28 patients received pre-transplant conditioning before HSCT, those who did not receive were in the SCID group, and one in the OS group (Table 4). The median (IQR) age at HSCT was 7 (4–13.5) mo, and the success of HSCT was 67.9% (19/28). There was a significant difference in the median (IQR) age at HSCT among the clinical groups ($P = 0.002$). Median age at HSCT was 6 (3.5–9.9) mo in the SCID group, and it was 90.3 (51.4–115.3) months in the CID group. All except P24 who did not receive pretransplant conditioning are alive and well after HSCT (16/17).

Twelve patients (SCID; 11, OS; 1) received immunosuppressive treatments (methylprednisolone and cyclosporine) for GVHD (Table 4). P21 with a previously reported homozygous RAG1 mutation (Y589*; c.1879C > G) [17] underwent HLA-identical HSCT from his mother at 4 mo of age. A liver biopsy for persistent transaminase elevation revealed GVHD. MPZ and cyclosporine (CYC) were given. Skin exfoliation, thickening, excoriation, and pancytopenia suggest bone marrow failure developed despite the treatment. Afterwards, he was diagnosed with chronic GVHD. He is under tacrolimus and mycophenolate mofetil (MMF) treatments for chronic GVHD. P24 had a novel RAG1 mutation and was diagnosed with isolated liver GVHD and treated with CYC, MMF, and etoposide. Liver functions deteriorated and progressive liver failure developed despite plasmapheresis and mesenchymal stem cell transplantation. All other patients with acute GVHD were treated with MPZ and/or CYC (Table 4).

Table 2. Characteristics of the RAG deficient patients

Patients	Presentation	Gender	Age of manifestation (months)	Age at clinical diagnosis (months)	Consanguinity	Family history	Clinical symptoms	Skin findings	Cytopenia	Other autoimmune/inflammatory disease	Vaccine-related disease
P1	SCID**	M	2	6	Yes	Yes	Diarrhea, pneumonia	No	No	HM and LAP	No
P2†	SCID	M	0	3.5	Yes	Yes	Oral thrush, diarrhea, and RLRTI	No	No	HSM	No
P3†	SCID	M	1	1	Yes	Yes	Pneumonia	Dermatitis	HA and ITP (after HSCT and DC-)	No	No
P4	SCID	M	4	7	No	No	RLRTI, RURTI, skin abscess, oral thrush, diarrhea, and USI	Dermatitis	No	HM	No
P5	SCID	M	4	6	Yes	Yes	Perianal abscess, diarrhea, and oral thrush	Dermatitis	No	HM and LAP	BCG lym-phadenitis
P6†	SCID	M	1	6	Yes	Yes	Oral thrush, diarrhea, pneumonia	No	No	No	No
P7†	SCID	F	1.5	5	Yes	Yes	USI pneumonia	No	No	No	BCG lym-phadenitis
P8	SCID	M	0.5	2	Yes	Yes	oral thrush, diarrhea	No	ITP (6 years after HSCT)	HM	No
P9	SCID	F	0	6	No	No	RLRTI, skin abscess, oral thrush, diarrhea, aphthous stomatitis	SD	No	No	BCG lym-phadenitis
P10	SCID	F	1	2.5	Yes	No	RLRTI, skin abscess, oral thrush, and diarrhea	No	No	No	No
P11	SCID	F	1	10	Yes	No	CMV retinitis, oral thrush, diarrhea, and pneumonia	Dermatitis	ITP (CMV)	HM, LAP	No
P12	SCID	M	3	5	Yes	No	RLRTI and oral thrush	Whitish patches	No	HM	No
P13	SCID	F	1	3	No*	No	Oral thrush and pneumonia	No	AIHA (6 months after HSCT)	No	No
P14	SCID	M	1	7	Yes	No	RURTI, oral thrush, and aphthous stomatitis	DD	Leukopenia (bone marrow failure after HSCT)	HM	No
P15	SCID	M	2	3	Yes	No	Oral thrush and diarrhea	No	No	HM	No
P16*	SCID	M	0	3	Yes	Yes	Oral thrush, RLRTI, and RURTI	No	No	No	No
P17*	SCID	M	1	3	Yes	Yes	Oral thrush and CMV pneumonia	No	No	No	No

Table 2. Continued

Patients	Presentation	Gender	Age of manifestation at clinical diagnosis (months)	Age (months)	Consanguinity	Family history	Clinical symptoms	Skin findings	Cytopenia	Other autoimmune/inflammatory disease	Vaccine-related disease
P18	SCID	M	6	11	Yes	Yes	RLTI and RURTI	No	No	No	No
P19	SCID	M	2	2	No	Yes	RLTI	Dermatitis	No	No	No
P20	SCID	M	1.5	4	Yes	No	RLTI, oral thrush, diarrhea, and CMV retinitis	DD	No	No	No
P21	SCID	M	0.5	4	Yes	Yes	Oral thrush and pneumonia	No	Pancytopenia (bone marrow failure, after HSCT)	No	BCG lymphadenitis
P22	SCID	M	2	3	Yes	Yes	Diarrhea, pneumonia, oral thrush, and CMV pneumonia	DD	No	HM	No
P23	SCID	F	0.5	3	Yes	Yes	Diarrhea and oral thrush	DD	No	HM	No
P24	SCID	M	0.66	1.5	Yes	No	Pneumonia and USI	Dermatitis	No	No	No
P25	SCID	M	0	0.2	No	Yes		DD	No	No	No
P26 [†]	OS	F	0.5	4.5	Yes	Yes	Pneumonia and diarrhea	Ichthyosis and alopecia	No	HM	No
P27 [†]	OS	F	2	2.5	No	Yes	Pneumonia and diarrhea	Ichthyosis and alopecia	No	LAP	No
P28	OS	F	6	10	Yes	No	Oral thrush, RURTI, and pneumonia	SD, alopecia, and nail dystrophy	No	HM	No
P29	OS	F	4	9.5	Yes	No	Diarrhea, pneumonia, and oral thrush	SD	No	HM	No
P30	OS	F	2	2.5	Yes	Yes	RLRTI, oral thrush, diarrhea, and CMV pneumonia	SD, alopecia, and DD	No	HSM	No
P31 [*]	CID	M	7	78	Yes	Yes	RLRTI, bronchiectasis, and CMV pneumonia	Warts	No	LAP	No
P32 [*]	CID	F	36	62	Yes	Yes	RLRTI	Warts and vitiligo	No	LAP	No
P33	CID ^{**}	M	0.25	10	No	No	RLRTI, diarrhea, eczema, oral thrush, and CMV pneumonia	Granulomatous dermatitis	No	LAP	No
P34	CID	M	14	27	Yes	No	Pneumonia, hemoptysis, and pulmonary hemosiderosis	Necrotic wounds	No	Necrotizing vasculitis	No

Table 2. Continued

Patients	Presentation	Gender	Age of manifestation at clinical diagnosis (months)	Age at clinical diagnosis (months)	Consanguinity	Family history	Clinical symptoms	Skin findings	Cytopenia	Other autoimmune/inflammatory disease	Vaccine-related disease
P35	CID**	M	18	19	Yes	No	Candida cruzei pneumonia, RLRTI	No	No	Progressive neuropathy	No

DC: direct coombs; DD: diaper dermatitis; HA: hemolytic anemia; HM: hepatomegaly; HSM: hepatosplenomegaly; GIS: gastrointestinal; ITP: immune thrombocytopenic purpura; LAP: lymphadenopathy; RLRTI: recurrent lower respiratory tract infections; RURT: recurrent upper respiratory tract infections; SD: Seborrheic dermatitis; USI: urinary system infections.

*Cousins: P2 and P3; P6 and P7; P26 and P27; †siblings: P16 and P17; P31 and P32; P1, P33, and P35; **: Do not exactly fulfill the ESID criteria.

Autoimmune cytopenia developed in two SCID patients after HSCT. P8 developed idiopathic thrombocytopenic purpura (ITP) 6 years after HSCT [17], and he was successfully treated with intravenous immunoglobulin (IVIG) therapy. Autoimmune hemolytic anemia developed 6 mo after HSCT in P13 with a novel RAG2 mutation. Unfortunately, despite the treatment [IVIG, pulse steroids, plasmapheresis (three times), CYC, cyclophosphamide, rituximab, and MMF] and supportive care for persistent AIHA, the patient died before the second HSCT planned from another HLA-matched sibling donor.

In total, 16 patients died during the disease course, including nine patients who underwent HSCT (SCID; 6, OS; 1, and CID; 2). Nineteen patients (54.3%) are alive, and well after HSCT. The 10-year-survival analysis is shown in Fig. 3A for distinctive clinical groups, and in Fig. 3B according to the type of RAG deficiency. Survival differed in the groups; it was maximum in the SCID patients (64%) who mostly had an HLA-matched family donor, and minimum in the OS patients (20%) only P29 survived after a successful HSCT with the full-matched family donor. (Table 4). There was no difference between RAG1 and RAG2 deficient SCID patients in terms of HSCT outcomes, autoimmunity, and survival ($P > 0.05$).

Discussion

Here, we present a large cohort of RAG $\frac{1}{2}$ deficient patients (25 patients with RAG1, 10 with RAG2 deficiency) during a 20-year period from Turkish origin with nine novel mutations. In our study patients were classified as SCID, OS, and CID, and it was also depicted that identical mutations can cause distinct clinical presentations. All novel mutations except one caused SCID phenotype. We believe that the identified novel variants in this study can contribute to the literature, and help to understand the nature of the RAG deficiency.

RAG deficiency was described in various studies from all over the world with different clinical pictures from the first cases until today with raising awareness. RAG mutations were particularly reported from highly consanguineous populations for instance Middle East region [30–32] and Turkey [33, 34], whereas there were also large case series from the Slavic countries [35], Italy [36] and Latin America [37] in which consanguineous marriages seen relatively less common. Noteworthy, similar mutations have been reported from different ethnic origins requiring more research.

Due to the high rate of consanguinity in our population [38, 39], we had a higher rate of homozygous mutations compared to other European nations [36]. RAG $\frac{1}{2}$ deficiency is the predominant genetic reason for SCID phenotype in Turkey, and the reported frequency among studies varies between 15.4% and 26% [6, 40]. Furthermore, in the present study, most of the patients had SCID phenotype similar to the studies from the Middle East region [30, 32], and in contrast to Slavic [35] and Italian [36] cohorts in which OS was more prevalent.

The RAG $\frac{1}{2}$ gene mutations have a broad spectrum of phenotypes, ranging from SCID, OS, and delayed-onset CID/AS. The RAG deficient patients with SCID and OS generally present with opportunistic infections in early infancy. Diagnosis of delayed-onset CID due to hypomorphic RAG $\frac{1}{2}$ deficiency is more challenging due to clinical variation. In some patients, the diagnosis may not be possible [9, 41].

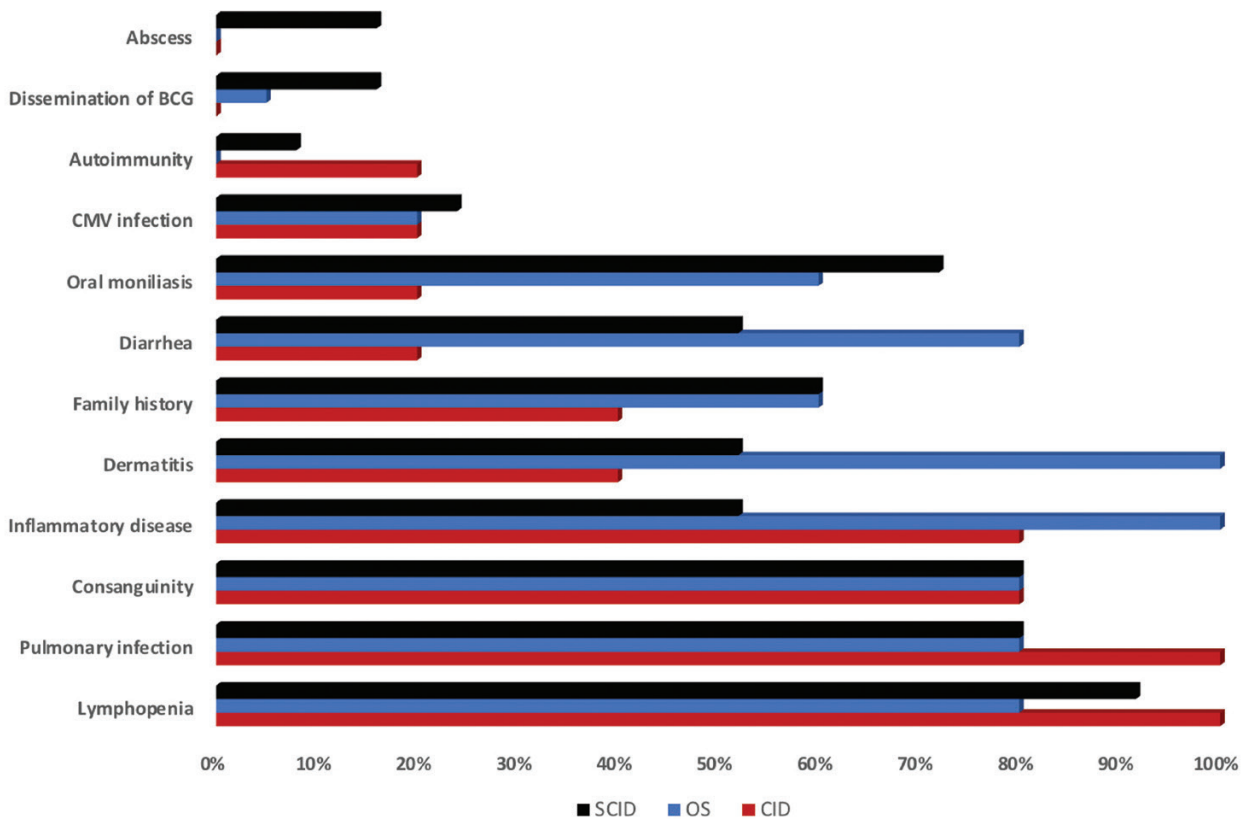

Figure 2. Common clinical manifestations of RAG deficient patients. Inflammatory disease: hepatomegaly and/or splenomegaly, lymphadenopathy

A single mutation may result in a variety of clinical manifestations [7, 13, 16]. Patients with the same RAG mutation may have different phenotypes even in the same family [42], possibly due to epigenetic factors including gene modifiers, environmental factors, infections, and iatrogenic factors [43]. Furthermore, researchers showed that similar mutations in the N-terminal truncation of the RAG1 protein cause different RAG residual protein activity, which leads to distinct clinical phenotypes [44].

The published studies regarding RAG1 and RAG2 deficiencies indicated that more than 60 RAG1 and RAG2 mutations are located in the core regions of the RAG proteins and they affect DNA binding, catalytic activity, or protein stabilization [45]. The core region mutations in our study also comprised the majority of the identified variants. In addition, two patients in our study with OS had a non-core region variant like in the articles of Grazzini *et al.* [46] and Matthews *et al.* [47]. These OS patients had severe ichthyosis-like skin lesions and alopecia, and unfortunately deceased before HSCT.

We observed an overall distribution of the causative variants including different types of monoallelic or biallelic variations located in different regions of the RAG1 and RAG2 genes. In addition, we did not detect a founder variant like in the study reported from Slavic countries [35]. Although the consanguinity rate is high among our patients, we think that they are coming from different regions of the country.

In our study group, most of the patients had RAG1 mutations in line with the literature [35, 36]. Interestingly, the majority of the novel mutations were RAG2 mutations

presenting with SCID phenotype. P13 and P14 in the SCID group had the same novel homozygous missense mutation in the RAG2 protein core region, which is proposed to disturb the interaction with RAG1 and recombination signal sequence (RSS) and leads to RAG2 c.2152G > T mutation causing p.Trp317Cys. The tryptophan at this position is essential for interaction with RAG1 and cleavage of the DNA and the RSS [48, 49].

In the present study, recruiting some of the patients (P1, P33, and P35) to a clinical group according to the ESID criteria was challenging. Other parameters and clinical characteristics were indicative in grouping. The estimated prevalence of RAG^{1/2} mutations, leading to partial enzyme activity and a later presentation varies between 1% and 1.9% in adult PID cohorts [50]. An important finding of this cohort is that the ratio of hypomorphic defects was shown to be 5/25 (20%) for RAG1 deficiency.

Granulomatous diseases were first identified in three patients with compound heterozygous RAGD mutations [10]. Granulomatous lymphocytic interstitial lung disease (GLILD) may be associated with RAGD [51]. Granulomatous skin lesions were present in P33, a delayed-onset CID patient, who had previously reported compound heterozygous RAG1 mutations (c.537G > A/ c.1443C > T; R142Q/A444V) [17, 25].

Treatment-resistant severe vasculitis was present in P34 and complicated with digital necrosis [26, 27]. He had a relatively delayed-onset CID caused by a homozygous RAG1 mutation (c.2095C > T; R699W). Similarly, in our study vasculitis was reported in RAG deficient patients. Henderson *et al.*

Table 3. Laboratory findings of RAG deficient patients

Patients	WBC (/mm ³)	ALC (/mm ³)	ANC(/mm ³)	AEC (/mm ³)	IgA (mg/dl)	IgG (mg/dl)	IgM (mg/dl)	IgE (IU/l)	CD3**	CD4**	CD8**	CD16 + 56**	CD19**
SCID													
P1	8900	4806	1900	800	251 7-123	4090	32-203	<1	17/49-76 817	11/31-56 528	21/12-24 1009	79/3-15 3796	1/14-37 48
P2†	4100	984	2700	80	27 13.5-72	88 294-1165	33-154	N/A	1900-5900 1.8/51-77 18	1400-4300 1.9/35-56 19	500-1700 41/12-23 403	160-950 73.2/3-14 718	610-2600 2.6/11-41 26
P3†	6300	1000	3300	1400	<6.67 11-14	402 633-1466	22-87	<1	2500-5600 2/53-84 20	1800-4000 N/A	590-1600 N/A	170-830 N/A	430-3000 2/6-32 20
P4	5400	1200	2800	500	9.7 7-123	11 304-1231	32-203	8.8	2500-5500 28/49-76 336	16.7 200	27/12-24 324	57.7/3-15 692	0.2/14-37 2.4
P5	3800	700	800	400	0 7-123	177 304-1231	32-203	<1	1900-5900 0/49-76 0	1400-4300 3/31-56 21	500-1700 46/12-24 322	160-950 79/3-15 553	610-2600 0/14-37 0
P6†	4700	940	2500	0	<6.67 7-123	404 304-1231	32-203	<1	1900-5900 0/49-76 0	1400-4300 7/31-56 66	500-1700 32/12-24 300	160-950 66.8/3-15 628	610-2600 0/14-37 0
P7†	1100	300	400	0	18 13.5-72	120 294-1165	33-154	<1	1900-5900 0/51-77 0	1400-4300 3/35-56 9	500-1700 44/12-23 132	160-950 95/3-14 285	610-2600 0/11-41 0
P8	17000	1000	15600	300	8 13.5-72	580 294-1165	33-154		2500-5600 0/53-84 0	1800-4000 2/35-64 20	590-1600 26/12-28 260	170-830 57/4-18 570	430-3000 0/6-32 0
P9	2800	400	1500	100	21 7-123	110 304-1231	32-203	<1	2500-5500 2/49-76 8	1600-4000 5/31-56 20	560-1700 46/12-24 184	170-1100 86/3-15 344	300-2000 0/14-37 0
P10	3200	400	1700	100	21 26-296	510 604-1941	71-235	100	1900-5900 10/56-75 40	1400-4300 17/28-47 68	500-1700 33/16-30 132	160-950 87/4-17 348	610-2600 0/14-33 0
P11	20300	10200	8932	100	47.3 17-107	641 463-1006	46-159	11.3	1400-3700 11.3/49-76 1153	700-2200 7.38/31-56 752	490-1300 24.5/12-24 2499	130-720 70.8/3-15 7221	390-1400 3.69/14-37 376
P12	6300	1260	4400	500	35 13.5-72	120 294-1165	33-154	<1	1900-5900 0.9/51-77 11	1400-4300 1.8/35-56 24	500-1700 41.5/12-23 529	160-950 84.7/3-14 1071	610-2600 0.7/11-41 10
									2500-5600	1800-4000	590-1600	170-830	430-3000

Table 3. Continued

Patients	WBC (/mm ³)	ALC (/mm ³)	ANC(/mm ³)	AEC (/mm ³)	IgA (mg/dl)	IgG (mg/dl)	IgM (mg/dl)	IgE (IU/l)	CD3**	CD4**	CD8**	CD16 + 56**	CD19**
P13	4100	100	3000	0	24 13.5-72	420 294-1165	17 33-154	18.3	0/51-77 0	0.4/35-56 0.4	0.4/12-23 0.4	93/3-14 93	0.4/11-41 0.4
P14	100	0	0.1	0	<2.2 7-123	884 304-1231	19 33-154	<18	13/49-76 0	0/31-56 0	39/12-24 0	57/3-15 0	0/14-37 0
P15	2800	900	1400	0	<6.67 13.5-72	69.9 294-1165	<4.17 33-154	<1	0/51-77 0	1/35-56 9	16/12-23 144	86/3-14 774	0/11-41 0
P16*	4600	800	2900	100	<6.67 13.5-72	136 294-1165	<4.17 33-154	<1	0.1/51-77 0.8	51.1/35-56 1800-4000	2.5,2/12-23 201	57,1/3-14 456	0.64/11-41 5
P17*	1700	200	1200	0	<6.67 13.5-72	755 294-1165	<4.17 33-154	<1	1/51-77 2	0/35-56 0	3/12-23 6	9/3-14 18	4/11-41 8
P18	11900	900	9300	700	225 17-69	1150 463-1006	168 46-159	935	16/49-76 144	13/31-56 117	27/12-24 243	67/3-15 603	8/14-37 72
P19	3400	400	2000	200	18 13.5-72	290 294-1165	8 33-154	<1	16/53-84 64	19/35-64 76	20/12-28 80	64/4-18 256	0.6/6-32 2.4
P20	7700	1100	5400	0	<6.67 13.5-72	137 294-1165	<4.17 33-154	66	2/51-77 22	1/35-56 11	24/12-23 264	65/3-14 715	2/11-41 22
P21	5100	900	2900	200	<6.67 13.5-72	102 294-1165	6.33 33-154	<1	0/51-77 0	73/35-56 63	13/12-23 117	72/3-14 648	1/11-41 9
P22	7400	1100	4000	0	<6.67 13.5-72	191 294-1165	<4.17 33-154	<1	2500-5600 4/53-84	1800-4000 6/35-64	590-1600 8/12-28	170-830 66/4-18	430-300 4/6-32
P23	4600	800	3600	100	<6.67 13.5-72	262 294-1165	<4.17 33-154	<1	2500-5600 1/53-84	1800-4000 3/35-64	590-1600 26/12-28	170-830 85/4-18	430-300 0/6-32
P24	8400	1300	4500	1200	<6.67 9-30	367 376-685	44,1 36-77	43,1	2500-5600 36/53-84	1800-4000 36/35-64	590-1600 26/12-28	170-830 56/4-18	430-300 0/6-32
P25	11600	100	9600	500	<6.67 11-14	888 633-1466	<4.17 22-87	<1	2500-5500 64/53-84	1600-4000 10/35-64	560-1700 54/12-28	170-1100 28/4-18	300-2000 0/6-32
									64	10	54	28	0
									2500-5500	1600-4000	560-1700	170-1100	300-2000

Table 3. Continued

Patients	WBC (/mm ³)	ALC (/mm ³)	ANC(/mm ³)	AEC (/mm ³)	IgA (mg/dl)	IgG (mg/dl)	IgM (mg/dl)	IgE (IU/l)	CD3**	CD4**	CD8**	CD16 + 56**	CD19**
OS													
P26†	25600	10240	3072	2560	17.7 13.5–72	126 294–1165	10.7 33–154	<1	9/49–76 921	9/31–56 921	23/12–24 2355	83/3–15 8397	0/14–37 0
P27†	12200	1220	7320	1220	<6.67 13.5–72	226 294–1165	<4.17 33–154	<1	2500–5600 21/53–84 240	1800–4000 17/35–64 200	590–1600 28/12–28 380	170–830 68/4–18 850	430–3000 0/6–32 0
P28	7200	2400	1400	500	11 17–69	61 463–1006	32 32–203	>1000	2500–5500 84.2/49–76 2016	1600–4000 41.1/31–56 984	560–1700 52.7/12–24 1264	170–1100 13.5/3–15 324	300–3000 0.5/14–37 12
P29	20500	2240	15000	470	<30 17–69	<160 463–1006	<22 32–203	5	1900–5900 31/49–76 694	1400–4300 29/31–56 650	500–1700 24/12–24 537	160–950 53/3–15 1187	610–2600 0/14–37 0
P30	4900	500	1300	2600	<6.67 13.5–72	1180*** 294–1165	5.84 33–154	<1	1900–5900 16/51–77 80	1400–4300 17/35–64 200	500–1700 24/12–23 120	160–950 64/3–14 320	610–2600 2/11–41 10
CID													
P31*	19700	1000	17500	100	208 70–303	1040 764–2134	150 69–387	5.37	45/60–76 450	19/31–47 190	24/18–35 240	46/4–17 460	8/13–27 80
P32*	5300	1000	3500	200	48.7 57–282	939 745–1804	154 78–261	14.4	1200–2600 21/56–75 210	650–1500 13/28–47 130	370–1100 28/16–30 280	100–480 40/4–17 400	270–860 8/14–33 80
P33	4400	2600	1000	0	12 17–69	560 463–1006	46–59	<1	1400–3700 49/49–76 1274	700–2200 36/31–56 936	490–1300 9/12–24 234	130–720 44/3–15 1144	390–1400 1/14–37 26
P34	10500	1000	9100	0	36.2 26–296	1020 604–1941	47.3 71–235	2.55	1900–5900 45/56–75 450	1400–4300 23/28–47 230	500–1700 35/16–30 350	160–950 36/4–17 360	610–2600 9/14–33 90
P35	2200	300	900	0	11 30–107	14 605–1430	66–228	<1	1400–3700 40/53–75 120	700–2200 21/32–51 63	490–1300 32/14–30 96	130–720 38/3–15 114	390–1400 0/16–35 0
									2100–6200	1300–3400	620–2000	180–920	720–2600

†: cousins; P2 and P3; P6 and P7; P26 and P27; †: siblings; P16 and P17; P31 and P32; **: [%-/mm³]; ***: after IVIG treatment; N/A: not applicable.
 AEC: Absolute eosinophil count; ALC: Absolute lymphocyte count; ANC: Absolute neutrophil count; WBC: White blood cell.
 All of the labs were measured in the first visit.

Table 4. Survival and outcomes of the RAG deficient patients

Patients	Presentation	HSCT/donor (HLA)	Age at HSCT (months)	Pre-transplant conditioning	GVHD	Complications	Outcome
P1	SCID**	Yes/sister (9/10)	7	No	Yes (grade 1/skin)	No	Alive
P2†	SCID	Yes/father (10/10)	4	No	No	No	Alive
P3†	SCID	Yes/mother (10/10)	1.5	No	Yes (grade 2/skin)	HA and ITP	Alive
P4	SCID	Yes/haplo (father) and haplo (mother)	16 and 25.5	Yes	No	Recurrent infections	Deceased
P5	SCID	Yes/haplo (father)	7	Yes	Yes (grade 3/skin and GIS)	PTLD	Alive
P6†	SCID	Yes/haplo (mother)	9	Yes	No	Sepsis	Deceased
P7†	SCID	Yes/sister (6/6)	5.5	No	Yes (grade 1–2/skin)	No	Alive
P8	SCID	Yes/sister (6/6)	2.5	No	Yes (grade 2/skin and liver)	ITP	Alive
P9	SCID	Yes/sister (10/10)	7 and 23	No	No	Booster HSCT (graft failure)	Alive
P10	SCID	Yes/sister (10/10)	26.5	No	No	No	Alive
P11	SCID	Yes/cousin (10/10)	11	No	No	CMV retinitis	Alive
P12	SCID	Yes/mother (10/10)	6	No	Yes (grade 1/skin)	Anemia and leukopenia	Alive
P13	SCID	Yes/haplo (father)	3.5	Yes	No	Treatment resistant AIHA	Deceased
P14	SCID	Yes/haplo (father)	13.5	Yes	No	Graft failure, sepsis, and neurologic complications	Deceased
P15	SCID	Yes/cousin (10/10)	6	No	No	No	Alive
P16*	SCID	Yes/MUD (9/10)	9.5	Yes	No	Pneumonia	Deceased
P17*	SCID	No		N/A			Deceased
P18	SCID	Yes/sister (10/10)	12.5	No	No	No	Alive
P19	SCID	No		N/A			Deceased
P20	SCID	Yes/sister (10/10)	4.5	No	Yes (grade 1/skin)	Blinded by CMV retinitis	Alive
P21	SCID	Yes/mother (10/10)	5	No	Yes (grade 2/skin and liver)	Pancytopenia and immunosuppressive therapy due to chronic GVHD	Alive
P22	SCID	Yes/sister (10/10)	3.5	No	Yes (grade 1/skin)	Acute GVHD	Alive
P23	SCID	No		N/A			Deceased
P24	SCID	Yes/mother (10/10)	3	No	Yes (isolated liver)	Isolated liver GVHD and pancytopenia	Deceased
P25	SCID	Yes/brother (10/10)	3.5	No	Yes (grade 1/skin)	No	Alive
P26†	OS	No		N/A			Deceased
P27†	OS	No		N/A			Deceased
P28	OS	Yes/mother (5/6)	24	Yes	Yes (grade 1–2/skin/ GIS and liver)	Abducens palsy and pneumonia	Deceased
P29	OS	Yes brother (10/10)	10	No	No	No	Alive
P30	OS	No		N/A			Deceased
P31*	CID	Yes/sister (10/10)	121	Yes	No	No	Alive
P32*	CID	Yes/MUD (10/10)	98	Yes	No	No	Alive
P33	CID**	No		N/A			Deceased
P34	CID	Yes/MUD (9/10)	82.5	Yes	No	Pneumonia and acute kidney failure	Deceased
P35	CID**	Yes/MUD (cord blood,10/10)	41	Yes	No	Bronchiolitis obliterans organizing pneumonia	Deceased

HA: hemolytic anemia; HLA: human leukocyte antigen; ITP: immune thrombocytopenic purpura; MUD: Match unrelated donor; N/A: Not applicable; PTLD: Post-transplant lymphoproliferative disorders.

†: cousins: P2 and P3; P6 and P7; P26 and P27.

*: siblings: P16 and P17; P31 and P32.

P1, P33 and P35**: Do not exactly fulfill the ESID criteria.

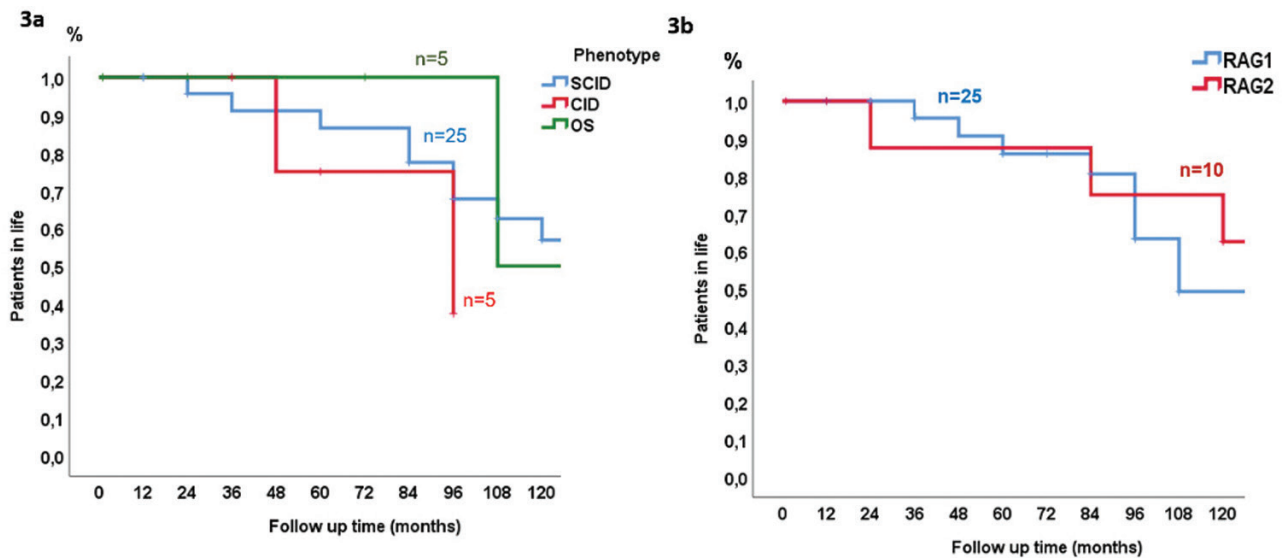

Figure 3 A. The survival analysis of the three distinct clinical groups. B. The survival analysis according to the type of RAG deficiency

al. described an early-onset autoimmune disease, Coombs (+) AIHA and vasculitis, causing digital necrosis, in a compound heterozygous RAG1 deficiency (c.2522 G > A; c.2920 T < C) [52]. Another compound heterozygous RAG1 deficiency patient again with a compound heterozygous defect (c.125A > G, M1V; c.2322 G > A, R737H) again presented with recurrent cutaneous vasculitis [13]. Partial RAG deficiency with vasculitis was reported in another study in six patients [53].

More than half of our patients (SCID; $n = 13$, OS; $n = 4$ and CID; $n = 1$) had a history of intractable diarrhea, a common symptom in SCID patients. It may present with IBD-like disease, autoimmune enteropathy, duodenitis, or severe noninfectious diarrhea. Detected infective agents are *pneumocystis jirovecii*, *Candida* species, and viral infections, such as cytomegalovirus (CMV) and adenovirus [54].

Viral infections are an important cause of morbidity and mortality in the course of RAG deficiency and are challenging for patients. Varicella infections, complicating with subsequent pneumonitis and ITP were reported in RAG-deficient patients [55, 56]. Another accompanying viral infection is CMV, which may progress to retinitis in PID patients. Early suspicion and effective treatment are crucial to prevent visual morbidity and loss in CMV retinitis [57, 58]. Two siblings (P31 and P32) diagnosed with CID presented with widespread warts in our cohort. Efficient cellular and cytotoxic immunity provided by T and NK cells is necessary to cope with HPV infections [59].

A wide range of autoantibodies, anti-cytokine antibodies, and neutralizing antibodies against interferon- α and interferon- ω , may develop in RAG-deficient patients following viral infections [56, 60]. A meta-analysis showed that autoimmunity and inflammatory diseases developed in 67.1% of 134 RAG deficiency. Autoimmune and inflammatory diseases have been reported in delayed-onset CID patients, whereas they were rare in OS and SCID patients [41]. Autoimmune cytopenia, granuloma, skin cancer, vasculitis, neuropathy, interstitial lung disease, and myopathy were detected in 76.2% of patients with RAG1, and 23.8% of the patients with RAG2 deficiency [41].

In our study, AIC developed after the HSCT was performed without a conditioning regimen (P8 and P13). Autoimmune cytopenia following HSCT, especially AIHA, was considered a serious post-HSCT complication with a poor prognosis [61]. Viral infections usually precede the onset of AIC [41]. The ratio of AIC was 2/35 (6%) in RAG $\frac{1}{2}$ deficiency in this cohort.

In the present study, 80% of all RAG $\frac{1}{2}$ patients who underwent HSCT had a survival rate of 54.3%. The median age at HSCT was 7 (4–13.5) mo, and the HSCT success in the RAG $\frac{1}{2}$ deficiency SCID group was 72.7% (16/22), a higher outcome than the general SCID–HSCT outcome (65.7% survival rate over 20 years) in Turkey [6]. Severe pneumonia was the leading cause of death in patients after HSCT. All RAG-deficient patients were diagnosed with SCID in a recently published study from Israel and the HSCT success rate was 68% [32]. The lack of newborn screening has a negative impact on the survival of our study patients, because, it causes a delay in both the PID diagnosis and timely HSCT.

In conclusion, we evaluated a considerable number of RAGD patients and identified certain novel mutations. A high proportion of patients presented with classical SCID phenotype. Early diagnosis, which will be accomplished after national neonatal screening, could improve clinical outcomes and survival. Patients with the lowest survival ratio, the delayed onset/CID patients, were the patients with the most frequent ratio of autoimmune/inflammatory findings. Thus, patients with autoimmunity and inflammation, including vasculitis, should be referred to immunology clinics and evaluated for delayed onset/CID. Early molecular diagnosis may also help in timely management. Definite and individualized therapeutic interventions which could only be possible after early diagnosis will provide a survival advantage, especially for delayed onset/CID patients until HSCT.

Supplementary Data

Supplementary data is available at *Clinical and Experimental Immunology* online.

Acknowledgements

Not applicable.

Ethical Approval

The study was approved by the Ethics Committee of Hacettepe University.

Conflict of Interests

The authors declare that they have no relevant conflict of interest related to this manuscript.

Funding

This study is supported by the Hacettepe University Coordination Unit for Scientific Research Projects (TSA-2016-9087).

Data Availability

All data are incorporated into the article and its online supplementary material.

Author Contributions

B.K. collected the data and participated in the review of the files, data generation, entry, and analysis, and wrote the manuscript. D.C. contributed to patient screening, collection of the data, data generation, data analysis, interpretation of the results and wrote the manuscript. S.E., O.S., and T.T.E. contributed to patient screening, data generation, and data analysis. B.E., K.B., M.B., and C.T. contributed to mutation analysis, data generation, and data analysis. I.T. supervised the study, contributed to patient screening, collection of the data, data generation, data analysis, interpretation of the results and wrote the manuscript with B.K. and D.C. All of the authors reviewed it critically for important intellectual content and agreed to be accountable for all aspects of the work related to its accuracy or integrity.

References

- Notarangelo LD, Kim M-S, Walter JE, Lee YN. Human RAG mutations: biochemistry and clinical implications. *Nat Rev Immunol* 2016, 16, 234–46. doi:10.1038/nri.2016.28.
- Schwarz K, Gauss GH, Ludwig L, Pannicke U, Li Z, Lindner D, et al. RAG mutations in human B cell-negative SCID. *Science* 1996, 274, 97–9. doi:10.1126/science.274.5284.97.
- Lee YN, Frugoni F, Dobbs K, Walter JE, Giliani S, Gennery AR, et al. A systematic analysis of recombination activity and genotype-phenotype correlation in human recombination-activating gene 1 deficiency. *J Allergy Clin Immunol* 2014, 133, 1099–1108.e12. doi:10.1016/j.jaci.2013.10.007.
- Tirosh I, Yamazaki Y, Frugoni F, Ververs FA, Allenspach EJ, Zhang Y, et al. Recombination activity of human recombination-activating gene 2 (RAG2) mutations and correlation with clinical phenotype. *J Allergy Clin Immunol* 2019, 143, 726–35. doi:10.1016/j.jaci.2018.04.027.
- Chinn IK, Shearer WT. Severe combined immunodeficiency disorders. *Immunol Allergy Clin* 2015, 35, 671–94.
- Ikinciogullari A, Cagdas D, Dogu F, Tugrul T, Karasu G, Haskologlu S, et al. Clinical features and HSCT outcome for SCID in Turkey. *J Clin Immunol* 2019, 39, 316–23. doi:10.1007/s10875-019-00610-x.
- Villa A, Santagata S, Bozzi F, Giliani S, Frattini A, Imberti L, et al. Partial V (D) J recombination activity leads to Omenn syndrome. *Cell* 1998, 93, 885–96. doi:10.1016/s0092-8674(00)81448-8.
- Omenn GS. Familial reticuloendotheliosis with eosinophilia. *N Engl J Med* 1965, 273, 427–32. doi:10.1056/nejm196508192730806.
- Delmonte OM, Schuetz C, Notarangelo LD. RAG deficiency: two genes, many diseases. *J Clin Immunol* 2018, 38, 646–55. doi:10.1007/s10875-018-0537-4.
- Schuetz C, Huck K, Gudowius S, Megahed M, Feyen O, Hubner B, et al. An immunodeficiency disease with RAG mutations and granulomas. *N Engl J Med* 2008, 358, 2030–8. doi:10.1056/nejmoa073966.
- Kuijpers TW, Ijspeert H, van Leeuwen EMM, Jansen MH, Hazenberg MD, Weijer KC, et al. Idiopathic CD4+ T lymphopenia without autoimmunity or granulomatous disease in the slipstream of RAG mutations. *Blood* 2011, 117, 5892–6. doi:10.1182/blood-2011-01-329052.
- Kato T, Crestani E, Kamae C, Honma K, Yokosuka T, Ikegawa T, et al. RAG1 deficiency may present clinically as selective IgA deficiency. *J Clin Immunol* 2015, 35, 280–8. doi:10.1007/s10875-015-0146-4.
- Geier CB, Piller A, Linder A, Sauerwein KM, Eibl MM, Wolf HM. Leaky RAG deficiency in adult patients with impaired antibody production against bacterial polysaccharide antigens. *PLoS One* 2015, 10, e0133220. doi:10.1371/journal.pone.0133220.
- Chou J, Hanna-Wakim R, Tirosh I, Kane J, Fraulino D, Lee YN, et al. A novel homozygous mutation in recombination activating gene 2 in 2 relatives with different clinical phenotypes: Omenn syndrome and hyper-IgM syndrome. *J Allergy Clin Immunol* 2012, 130, 1414–6. doi:10.1016/j.jaci.2012.06.012.
- E. o. A. a. “ESID. org. Available at: <https://esid.org/Education/Diagnostic-criteria-PID#>”. (accessed).
- Tange SG, Al-Herz W, Bousfha A, Cunningham-Rundles C, Franco JL, Holland SM, et al. Human inborn errors of immunity: 2022 update on the classification from the international union of immunological societies expert committee. *J Clin Immunol* 2022, 42, 1473–507. doi:10.1007/s10875-022-01289-3.
- Villa A, Sobacchi C, Notarangelo LD, Bozzi F, Abinun M, Abrahamson TG, et al. V(D)J recombination defects in lymphocytes due to RAG mutations: severe immunodeficiency with a spectrum of clinical presentations. *Blood* 2001, 97, 81–8. doi:10.1182/blood.v97.1.81.
- Al-Mousa H, Al-Dakheel G, Jabr A, Elbadaoui F, Abouelhoda M, Baig M, et al. High incidence of severe combined immunodeficiency disease in Saudi Arabia detected through combined T cell receptor excision circle and next generation sequencing of newborn dried blood spots. *Front Immunol* 2018, 9, 782. doi:10.3389/fimmu.2018.00782.
- Willmann KL, Klaver S, Doğu F, Santos-Valente E, Garncarz W, Bilic I, et al. Biallelic loss-of-function mutation in NIK causes a primary immunodeficiency with multifaceted aberrant lymphoid immunity. *Nat Commun* 2014, 5, 1–13.
- Bai X, Liu J, Zhang Z, Liu C, Zhang Y, Tang W, et al. Clinical, immunologic, and genetic characteristics of RAG mutations in 15 Chinese patients with SCID and Omenn syndrome. *Immunol Res* 2016, 64, 497–507. doi:10.1007/s12026-015-8723-4.
- Schuetz C, Neven B, Dvorak CC, Leroy S, Ege MJ, Pannicke U, et al. SCID patients with ARTEMIS vs RAG deficiencies following HCT: increased risk of late toxicity in ARTEMIS-deficient SCID. *Blood J Am Soc Hematol* 2014, 123, 281–9. doi:10.1182/blood-2013-01-476432.
- Sobacchi C, Marrella V, Rucci F, Vezzoni P, Villa A. RAG-dependent primary immunodeficiencies. *Hum Mutat* 2006, 27, 1174–84. doi:10.1002/humu.20408.
- Xiao Z, Yannone SM, Dunn E, Cowan MJ. A novel missense RAG-1 mutation results in T– B– NK+ SCID in Athabaskan-speaking Ine

- Indians from the Canadian Northwest territories. *Eur J Hum Genet* 2009, 17, 205–12. doi:10.1038/ejhg.2008.150.
24. Kutukculer N, Gulez N, Karaca NE, Aksu G, Berdeli A. Novel mutations and diverse clinical phenotypes in recombinase-activating gene 1 deficiency. *Ital J Pediatr* 2012, 38, 1–7. doi:10.1186/1824-7288-38-8.
 25. Erman B, Bilic I, Hirschmugl T, Salzer E, Boztug H, Sanal O, et al. Investigation of genetic defects in severe combined immunodeficiency patients from Turkey by targeted sequencing. *Scand J Immunol* 2017, 85, 227–34. doi:10.1111/sji.12523.
 26. Avila EM, Uzel G, Hsu A, Milner JD, Turner ML, Pittaluga S, et al. Highly variable clinical phenotypes of hypomorphic RAG1 mutations. *Pediatrics* 2010, 126, e1248–52. doi:10.1542/peds.2009-3171.
 27. Taşkıran EZ, Sönmez HE, Ayvaz D, Koşukcu C, Batu ED, Esenboğa S, et al. Hypomorphic RAG1 defect in a child presented with pulmonary hemorrhage and digital necrosis. *Clin Immunol* 2018, 187, 92–4. doi:10.1016/j.clim.2017.10.010.
 28. Marciano BE, Huang C-Y, Joshi G, Rezaei N, Carvalho BC, Allwood Z, et al. BCG vaccination in patients with severe combined immunodeficiency: complications, risks, and vaccination policies. *J Allergy Clin Immunol* 2014, 133, 1134–41. doi:10.1016/j.jaci.2014.02.028.
 29. Shearer WT, Rosenblatt HM, Gelman RS, Oyomopito R, Plaeger S, Stiehm ER, et al. Lymphocyte subsets in healthy children from birth through 18 years of age: the Pediatric AIDS Clinical Trials Group P1009 study. *J Allergy Clin Immunol* 2003, 112, 973–80. doi:10.1016/j.jaci.2003.07.003.
 30. Meshaal SS, El Hawary RE, Abd Elaziz DS, Eldash A, Alkady R, Lotfy S, et al. Phenotypical heterogeneity in RAG-deficient patients from a highly consanguineous population. *Clin Exp Immunol* 2019, 195, 202–12. doi:10.1111/cei.13222.
 31. Alsmadi O, Al-Ghoniaim A, Al-Muhsen S, Arnaout R, Al-Dhekri H, Al-Saud B, et al. Molecular analysis of T–B–NK+ severe combined immunodeficiency and Omenn syndrome cases in Saudi Arabia. *Med Genet* 2009, 10, 116. doi:10.1186/1471-2350-10-116.
 32. Greenberg-Kushnir N, Lee YN, Simon AJ, Lev A, Marcus N, Abuzaitoun O, et al. A large cohort of RAG½-deficient SCID patients—clinical, immunological, and prognostic analysis. *J Clin Immunol* 2020, 40, 211–22. doi:10.1007/s10875-019-00717-1.
 33. Ulusoy E, Karaca NE, Azarsiz E, Berdeli A, Aksu G, Kutukculer N. Recombinase activating gene 1 deficiencies without Omenn syndrome may also present with Eosinophilia and bone marrow fibrosis. *J Clin Med Res* 2016, 8, 379–84. doi:10.14740/jocmr2316w.
 34. Patiroglu T, Akar HH, Burg MVD. Three faces of recombination activating gene 1 (RAG1) mutations. *Acta Microbiol Immunol Hung* 2015, 62, 393–401. doi:10.1556/030.62.2015.4.4.
 35. Sharapova SO, Skomska-Pawliszak M, Rodina YA, Wolska-Kuśnierz B, Dabrowska-Leonik N, Mikołuc B, et al. The clinical and genetic spectrum of 82 patients with RAG deficiency including a c. 256_257delAA founder variant in slavic countries. *Front Immunol* 2020, 11, 900. doi:10.3389/fimmu.2020.00900.
 36. Cifaldi C, Rivalta B, Amodio D, Mattia A, Pacillo L, Di Cesare S, et al. Clinical, immunological, and molecular variability of rag deficiency: a retrospective analysis of 22 rag patients. *J Clin Immunol* 2021, 42, 130–45. doi:10.1007/s10875-021-01130-3.
 37. Lugo-Reyes SO, Pastor N, González-Serrano E, Yamazaki-Nakashimada MA, Scheffler-Mendoza S, Berron-Ruiz L, et al. Clinical manifestations, mutational analysis, and immunological phenotype in patients with RAG½ mutations: first cases series from Mexico and description of two novel mutations. *J Clin Immunol* 2021, 41, 1291–302. doi:10.1007/s10875-021-01052-0.
 38. Alper OM, Erengin H, Manguoğlu AE, Bilgen T, Cetin Z, Dedeoğlu N, et al. Consanguineous marriages in the province of Antalya, Turkey. *Ann Genet* 2004, 47, 129–38. doi:10.1016/j.anngen.2003.09.001.
 39. T. 2016., “In: newsletter, no: 24646. <http://www.tuik.gov.tr.>”
 40. Sanal O, Tezcan I. Thirty years of primary immunodeficiencies in Turkey. *Ann NY Acad Sci* 2011, 1238, 15–23. doi:10.1111/j.1749-6632.2011.06242.x.
 41. Farmer JR, Foldvari Z, Ujhazi B, De Ravin SS, Chen K, Blesing JJH, et al. Outcomes and treatment strategies for autoimmunity and hyperinflammation in patients with RAG deficiency. *J Allergy Clin Immunol Pract* 2019, 7, 1970–1985.e4. doi:10.1016/j.jaip.2019.02.038.
 42. Schuetz C, Pannicke U, Jacobsen E-M, Burggraf S, Albert MH, Hönig M, et al. Lesson from hypomorphic recombination-activating gene (RAG) mutations: why asymptomatic siblings should also be tested. *J Allergy Clin Immunol* 2014, 133, 1211–1215.e2. doi:10.1016/j.jaci.2013.10.021.
 43. Niehues T, Perez-Becker R, Schuetz C. More than just SCID—the phenotypic range of combined immunodeficiencies associated with mutations in the recombinase activating genes (RAG) 1 and 2. *Clin Immunol* 2010, 135, 183–92. doi:10.1016/j.clim.2010.01.013.
 44. Ijspeert H, Driessen GJ, Moorhouse MJ, Hartwig NG, Wolska-Kuśnierz B, Kalwak K, et al. Similar recombination-activating gene (RAG) mutations result in similar immunobiological effects but in different clinical phenotypes. *J Allergy Clin Immunol* 2014, 133, 1124–1133.e1. doi:10.1016/j.jaci.2013.11.028.
 45. Kim M-S, Lapkouski M, Yang W, Gellert M. Crystal structure of the V(D)J recombinase RAG1–RAG2. *Nature* 2015, 518, 507–11. doi:10.1038/nature14174.
 46. Grazini U, Zanardi F, Citterio E, Casola S, Goding CR, McBlane F. The RING domain of RAG1 ubiquitylates histone H3: a novel activity in chromatin-mediated regulation of V (D) J joining. *Mol Cell* 2010, 37, 282–93. doi:10.1016/j.molcel.2009.12.035.
 47. Matthews AG, Briggs CE, Yamanaka K, Small TN, Mooster JL, Bonilla FA, et al. Compound heterozygous mutation of RAG1 leading to Omenn syndrome. *PLoS One* 2015, 10, e0121489. doi:10.1371/journal.pone.0121489.
 48. Aidinis V, Dias DC, Gomez CA, Bhattacharyya D, Spanopoulou E, Santagata S. Definition of minimal domains of interaction within the recombination-activating genes 1 and 2 recombinase complex. *J Immunol* 2000, 164, 5826–32. doi:10.4049/jimmunol.164.11.5826.
 49. Ichihara Y, Hirai M, Kurosawa Y. Sequence and chromosome assignment to 11p13-p12 of human RAG genes. *Immunol Lett* 1992, 33, 277–84. doi:10.1016/0165-2478(92)90073-w.
 50. Lawless D, Geier CB, Farmer JR, Lango Allen H, Thwaites D, Atschekzei F, et al.; NIHR Bio Resource–Rare Diseases Consortium. Prevalence and clinical challenges among adult primary immunodeficiency patients with RAG deficiency. *J Allergy Clin Immunol* 2018, 141, 2303–6. doi:10.1016/j.jaci.2018.02.007.
 51. John T, Walter JE, Schuetz C, Chen K, Abraham RS, Bonfim C, et al. Unrelated hematopoietic cell transplantation in a patient with combined immunodeficiency with granulomatous disease and autoimmunity secondary to RAG deficiency. *J Clin Immunol* 2016, 36, 725–32. doi:10.1007/s10875-016-0326-x.
 52. Henderson LA, Frugoni F, Hopkins G, de Boer H, Pai S-Y, Lee YN, et al. Expanding the spectrum of recombination-activating gene 1 deficiency: a family with early-onset autoimmunity. *J Allergy Clin Immunol* 2013, 132, 969–971.e2. doi:10.1016/j.jaci.2013.06.032.
 53. Geier CB, Farmer JR, Foldvari Z, Ujhazi B, Steininger J, Sleasman JW, et al. Vasculitis as a major morbidity factor in patients with partial RAG deficiency. *Front Immunol* 2020, 11, 1–10. doi:10.3389/fimmu.2020.574738.
 54. Bulkhi AA, Dasso JF, Schuetz C, Walter JE. Approaches to patients with variants in RAG genes: from diagnosis to timely treatment. *Exp Rev Clin Immunol* 2019, 15, 1033–46. doi:10.1080/1744666X.2020.1670060.
 55. Abolhassani H, Wang N, Aghamohammadi A, Rezaei N, Lee YN, Frugoni F, et al. A hypomorphic recombination-activating gene 1 (RAG1) mutation resulting in a phenotype resembling common variable immunodeficiency. *J Allergy Clin Immunol* 2014, 134, 1375–80. doi:10.1016/j.jaci.2014.04.042.

56. Walter JE, Rosen LB, Csomos K, Rosenberg JM, Mathew D, Keszei M, et al. Broad-spectrum antibodies against self-antigens and cytokines in RAG deficiency. *J Clin Invest* 2015, **125**, 4135–48. doi:[10.1172/JCI80477](https://doi.org/10.1172/JCI80477).
57. Bauml CR, Levin AV, Read SE. Cytomegalovirus retinitis in immunosuppressed children. *Am J Ophthalmol* 1999, **127**, 550–8. doi:[10.1016/s0002-9394\(99\)00031-8](https://doi.org/10.1016/s0002-9394(99)00031-8).
58. Ngai JJ, Chong KL, Oli Mohamed S. Cytomegalovirus retinitis in primary immune deficiency disease. *Case Rep Ophthalmol Med* 2018, **2018**, 8125806. doi:[10.1155/2018/8125806](https://doi.org/10.1155/2018/8125806).
59. Jw L, Sm H. Warts and all: HPV in primary immune deficiencies. *J Allergy Clin Immunol* 2012, **130**, 1030–48. doi:[10.1016/j.jaci.2012.07.049](https://doi.org/10.1016/j.jaci.2012.07.049).
60. Goda V, Malik A, Kalmar T, Maroti Z, Patel B, Ujhazi B, et al. Partial RAG deficiency in a patient with varicella infection, autoimmune cytopenia, and anti-cytokine antibodies. *J Allergy Clin Immunol Pract* 2018, **6**, 1769–1771.e2. doi:[10.1016/j.jaip.2018.01.015](https://doi.org/10.1016/j.jaip.2018.01.015).
61. Sherer Y, Shoenfeld Y. Autoimmune diseases and autoimmunity post-bone marrow transplantation. *Bone Marrow Transplant* 1998, **22**, 873–81. doi:[10.1038/sj.bmt.1701437](https://doi.org/10.1038/sj.bmt.1701437).