



Universiteit  
Leiden  
The Netherlands

## **An isolated crested newt population in Dutch coastal dunes: distribution relict or introduction?**

Brouwer, J. de; Helder, B.; France, J.M.; Visser, M.C. de; Struijk, R.P.J.H.;  
Wielstra, B.M.

### **Citation**

Brouwer, J. de, Helder, B., France, J. M., Visser, M. C. de, Struijk, R. P. J. H.,  
& Wielstra, B. M. (2023). An isolated crested newt population in Dutch  
coastal dunes: distribution relict or introduction? *Amphibia-Reptilia*, 44(1),  
19-26. doi:10.1163/15685381-bja10103

Version: Publisher's Version  
License: [Creative Commons CC BY 4.0 license](https://creativecommons.org/licenses/by/4.0/)  
Downloaded from: <https://hdl.handle.net/1887/3618232>

**Note:** To cite this publication please use the final published version (if applicable).



# An isolated crested newt population in Dutch coastal dunes: distribution relict or introduction?

Jurian de Brouwer<sup>1,2,\*</sup>, Bas Helder<sup>1,2,\*</sup>, James France<sup>1,2</sup>, Manon C. de Visser<sup>1,2</sup>,  
Richard P.J.H. Struijk<sup>3</sup>, Ben Wielstra<sup>1,2,\*\*</sup>

1 - Naturalis Biodiversity Center, P.O. Box 9517, 2300 RA Leiden, The Netherlands

2 - Institute of Biology Leiden, Leiden University, P.O. Box 9505, 2300 RA Leiden, The Netherlands

3 - Reptile, Amphibian and Fish Conservation Netherlands (RAVON), P.O. Box 1413, 6501 BK Nijmegen, The Netherlands

\*These authors contributed equally to this work.

\*\*Corresponding author; e-mail: ben.wielstra@naturalis.nl

ORCID iD: Wielstra: 0000-0002-7112-5965

Received 26 May 2022; final revision received 3 September 2022; accepted 15 September 2022;  
published online 1 December 2022; published in print 27 February 2023

Associate Editor: Mathieu Denoël

**Abstract.** Isolated distribution patches may represent local remnants of a formerly wider range or could have originated by human-mediated expansion beyond the natural range. Distinguishing between these two scenarios is not always straightforward. Northern crested newts (*Triturus cristatus*) in the Dutch coastal dunes are disconnected from the main species range by over 40 kilometres and whether they have been present historically is unclear. We genotyped crested newts from throughout the Netherlands for an mtDNA marker to determine the provenance of the coastal dune population. Because a closely related species, the Italian crested newt (*T. carnifex*), has an introduction history in the Netherlands, we also screened eight nuclear DNA SNP markers diagnostic for *T. cristatus* vs. *T. carnifex*. The crested newts from the coastal dunes carry a single *T. cristatus* mtDNA haplotype that naturally occurs in the south, but not the east, of the Netherlands. Therefore, we cannot distinguish if the population represents a natural distribution relict or is derived from an introduction. We find no evidence of genetic admixture with *T. carnifex* in the coastal dunes, but such admixture is apparent at another Dutch locality (far removed from a previously known genetically admixed population). Our study illustrates how difficult it can be to determine the origin of isolated populations.

**Keywords:** alien species, biogeography, DNA barcoding, exotic species, invasion genetics, phylogeography.

## Introduction

A peculiar biogeographical pattern is the presence of distribution pockets disconnected from a species' main distribution range. For low vagility species such as amphibians, natural long-distance colonization is unlikely. A way for such a disjunct distribution pattern to arise is when a species' range retracts, while it manages to hold on locally (Wilson et al., 2004). An example from European newts concerns the distribution relicts of a previously broader distribution of the alpine newt *Ichthyosaura alpestris* in Italy (Chiocchio et al., 2017) and Poland (Pabijan et al., 2009).

A disconnected distribution patch can also be accomplished by human-mediated dispersal. A plethora of cases are known of populations that have become established well outside the natural distribution range after introduction by humans (Simberloff, 2013). For example, two European newts have settled on the other side of the Earth through anthropogenic dispersal: alpine newts in New Zealand (Arntzen et al., 2016) and smooth newts *Lissotriton vulgaris* in Australia (Tingley et al., 2015).

In the newt cases mentioned above, there is little doubt about how the isolated distribution

pocket originated, but what if a species' natural distribution is poorly known and the distance between pocket and main range is relatively small? Here DNA barcoding could help (Hebert et al., 2003; Mir et al., 2021). A natural distribution relict would be expected to be genetically similar to populations from the nearest edge of the main distribution range. However, this would also be the case for an introduced population that was sourced from that same region. Yet, positive evidence for an introduction history can be provided if the isolated population is genetically dissimilar from the nearest edge of the main distribution range.

The northern crested newt *T. cristatus* occurs in central and northern Europe (Wielstra et al., 2015; Wielstra et al., 2017b) and covers the south and east of the Netherlands (Creemers and van Delft, 2009). A few 'eccentrically located' finds from c. a century ago stem from the Dutch coastal dunes (Bergmans and Zuiderwijk, 1986; Creemers and van Delft, 2009). After a long period without records (but note there was no proper monitoring program at the time), northern crested newts were reported again: in Meijndel northern crested newts are known to be present since at least the early 1970s (Wanders, 2002) and in the Westduinpark since only as recently as 2020 (National Database Flora & Fauna, NDFF).

The nearest native northern crested newt population is located over 40 kilometres away as the crow flies (well beyond the lifetime dispersal distance; Arntzen and Wallis, 1991; Kupfer and Kneitz, 2000; Haubrock and Altrichter, 2017; Unglaub et al., 2021). It is unclear if the isolated population in the coastal dunes is the remnant of a formerly larger natural distribution (Creemers and van Delft, 2009). Human-mediated establishment of the coastal dune population is a realistic scenario as well, considering that introductions of the common midwife toad *Alytes obstetricans*, naturally occurring only in the extreme southeast of the Netherlands (Vliegenthart et al., 2023), and of two non-native tree frog *Hyla* species (Kuijt et

al., 2023), have been well documented in the same area (albeit these only took place in the 21st century).

An additional complication, particularly related to species introduction, is the potential presence of (and hybridization between) multiple species. The Italian crested newt *T. carnifex* has been introduced throughout Europe and a well-documented introduction in the central Netherlands, in the Veluwe region, may have been initiated as early as the 1970s (Bogaerts, 2002; Meilink et al., 2015; Wielstra et al., 2016). The natural distribution ranges of northern and Italian crested newts meet at a narrow hybrid zone (Maletzky et al., 2010; Mikulíček et al., 2012; Wielstra et al., 2014; Mačát et al., 2019; Fahrbach et al., 2021) and the two species also readily hybridize where *T. carnifex* has been introduced into the range of *T. cristatus* (Brede et al., 2000; Arntzen, 2001; Maletzky et al., 2008; Brede, 2015; Dufresnes et al., 2016; Dufresnes et al., 2019; Hinneberg et al., 2022). Therefore, the presence of *T. carnifex* (alleles) needs to be considered when dealing with a crested newt population of unknown origin.

We test if crested newts from the coastal dunes carry (only) *T. cristatus* mtDNA haplotypes and, if so, if these are similar to *T. cristatus* mtDNA haplotypes from the main range in the Netherlands. Furthermore, we genotype eight nuclear DNA SNP markers that are diagnostic for *T. cristatus* vs. *T. carnifex* to test if decisively non-native *T. carnifex* alleles are present.

## Materials and methods

### Sampling and DNA extraction

From the Dutch coastal dunes, we included 22 individuals sampled throughout Meijndel and six individuals from the Westduinpark (fig. 1; supplementary table S1). We also included seven individuals from localities with an assumed introduction history from elsewhere in the Netherlands: two from Krimpen aan den IJssel, one from Oudeland, three from Norg and one from Breda. Another 40 individuals from 18 locations were collected throughout the native range in the Netherlands (fig. 1, supplementary table S1). Buccal or skin swabs were collected using 4N6FLOQSwab and

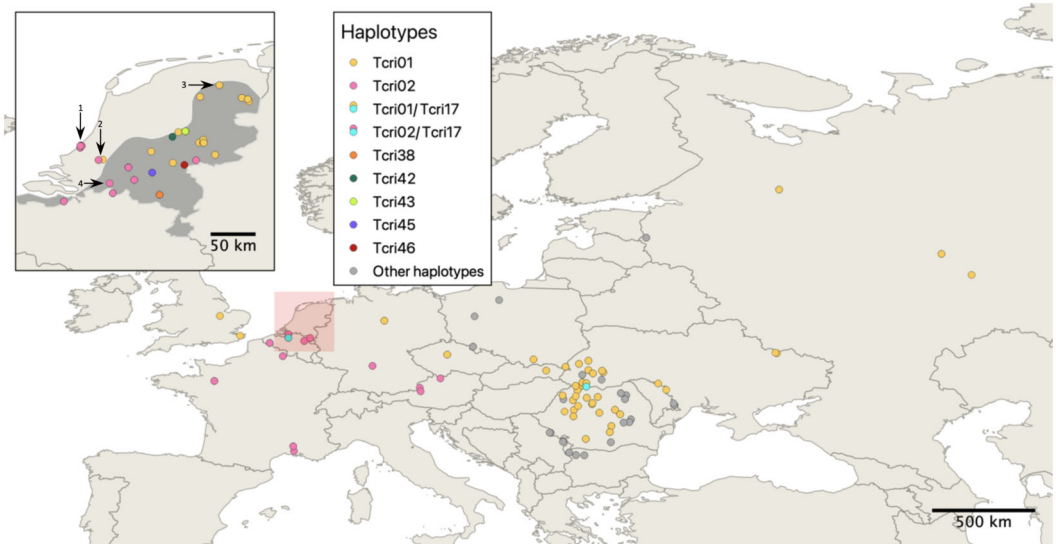

**Figure 1.** Sampled localities for the northern crested newt *Triturus cristatus*. The inset shows localities in the Netherlands, coloured based on ND4 mtDNA haplotype. Arrows highlight populations discussed in the text: 1) Meijendel and Westduinpark; 2) Krimpen aan den IJssel and Oudeland; 3) Norg; and 4) Breda. A rough outline of the natural distribution range in the Netherlands is shaded grey. See supplementary table S1 for details. The main map shows haplotype distribution in the rest of Europe and particularly focusses on those haplotypes also present in the Netherlands (see text for details).

stored in 96% ethanol at  $-20^{\circ}\text{C}$  until further use. DNA was extracted using a salt extraction protocol (Sambrook and Russell, 2001) with the Wizard<sup>®</sup> Genomic DNA Purification Kit (Promega). We also obtained DNA extracts from Belgium (12 individuals from four locations).

#### PCR and mtDNA analyses

We Sanger sequenced a 658 bp section of the mtDNA gene ND4, using the primer pair KARF4-DOBR2 (Wielstra et al., 2013). PCRs were performed in 12 microliter reactions containing 0.06  $\mu\text{l}$  forward and reverse primer (0.05  $\mu\text{M}$  end concentration of each primer), 7.2  $\mu\text{l}$  QIAGEN multiplex PCR master mix, 3.68  $\mu\text{l}$  purified water and 1  $\mu\text{l}$  of DNA extract. PCR conditions were: a hot start for 15 minutes at  $95^{\circ}\text{C}$ , followed by 35 cycles of denaturation for 30 seconds at  $95^{\circ}\text{C}$ , annealing for 1 minute at  $55^{\circ}\text{C}$  and extension for 1 minute at  $72^{\circ}\text{C}$ , and a final 30 minutes extension at  $60^{\circ}\text{C}$ . Sanger sequencing was performed commercially by BaseClear B.V. and sequences were edited using Geneious Prime 2021.1.1 (<https://www.geneious.com>).

The newly acquired ND4 sequences were aligned against a database of ND4 haplotypes for *Triturus* compiled from previous studies (Wielstra et al., 2013; Meilink et al., 2015; Wielstra et al., 2015; Wielstra et al., 2017a; Fahrbach et al., 2021). The Haplotype Collapser function in FaBox (Villesen, 2007) was used to check to which previously identified haplotypes our new sequences belonged (if any). To allocate newly identified haplotypes to *Triturus* species we used phylogenetics, specifically Bayesian inference in MrBayes v.3.2.2 (Ronquist et al., 2012). We included all available *T. cristatus* haplotypes and one haplotype of each

of the other *Triturus* species and used *Calotriton asper* as outgroup. The most appropriate models of sequence evolution (HKY+I, HKY+I and HKY for codon positions 1, 2 and 3) were determined with jmodeltest-2.1.10 (Darriba et al., 2012). We ran two, four-chain, ten-million-generation runs, with a sampling frequency of 0.001 and a heating parameter of 0.2 in MrBayes and used a 25% burnin. Tracer v1.7.1 (Rambaut et al., 2018) was used to confirm that runs converged and that ESS values were above 200. A haplotype network was made with TCS 1.21 (Clement et al., 2000) and tcsBU (Múrias dos Santos et al., 2015).

#### nuDNA screening for *Triturus carnifex* alleles

We genotyped eight previously described nuclear DNA SNP markers that are diagnostic for *T. carnifex* versus *T. cristatus* (Wielstra et al., 2016; Fahrbach et al., 2021). Genotyping was conducted using Kompetitive Allele Specific PCR (KASP) technology (LGC genomics, UK) at the SNP genotyping facility of the Institute of Biology, Leiden University. KASP genotyping involves fluorescence-based genotyping using allele specific primers that also contain a unique tail sequence. Different fluorescently labelled primers present in the KASP master mix correspond to each tail sequence and are activated when incorporated during subsequent PCR cycles, with further cycling causing signal intensity to increase (Semagn et al., 2014). Hence, for each marker for each individual, the presence of one or the other SNP variant, or both in the case of heterozygosity, can be determined.

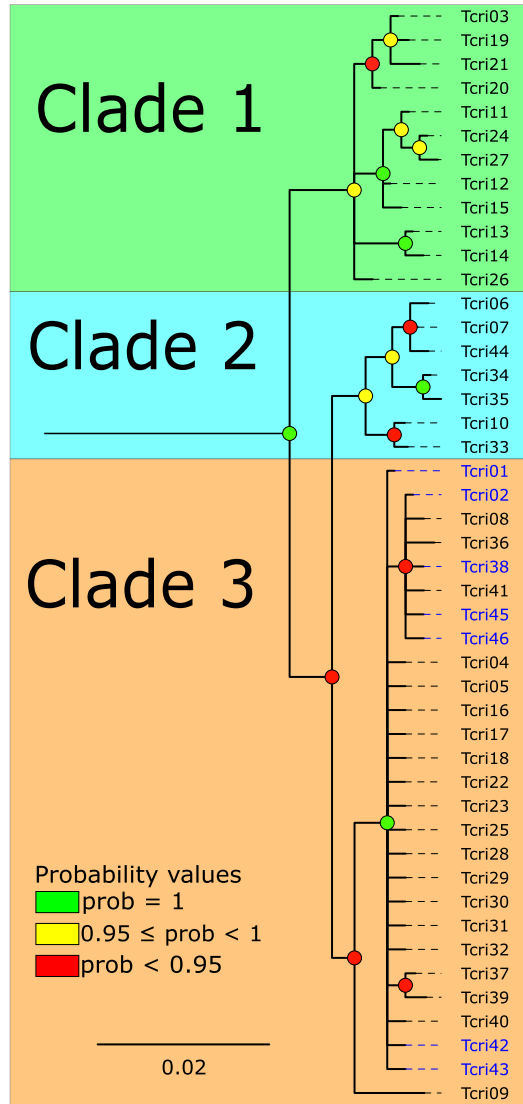

**Figure 2.** Bayesian phylogeny based on all ND4 mtDNA haplotypes of the northern crested newt *Triturus cristatus*. The outgroup is not shown. The scale bar shows the expected changes per site. The partitioning into three main clades is based on Wielstra et al. (2015). Haplotypes in blue are (also) present in the Netherlands. See supplementary table S1 for details.

## Results

Most of the newly sequenced individuals possessed previously identified *T. cristatus* haplotypes, mainly the haplotypes Tcri01 and Tcri02 (figs. 1 and 2, supplementary table S1). While Tcri01 occurs in the east of the Netherlands, Tcri02 is concentrated in the south; a pattern consistent with the distribution of these haplotypes across Europe (fig. 1). All samples from

Meijendel and Westduinpark belong to haplotype Tcri02. Populations with an assumed or known introduction history (Krimpen aan den IJssel, Oudeland, Norg and Breda; fig. 1 and supplementary table S1) possessed either the Tcri01 or Tcri02 haplotype. Two newly identified haplotypes, namely Tcri45 and Tcri46, as well as several additional haplotypes found in the studied individuals are all closely related

(belonging to 'clade 3' sensu Wielstra et al., 2015; fig. 2, supplementary fig. S1). One individual from Belgium contained the haplotype Tcri17, which was previously only reported in a single individual from north-western Romania. We found *T. carnifex* nuclear SNP alleles in one of the populations with an assumed introduction history (a single individual from Breda; supplementary table S1). All other localities only possessed *T. cristatus* nuclear SNP alleles.

## Discussion

We observe mtDNA diversity in *T. cristatus* across the Netherlands that fits within a wider western European context. Two haplotypes predominate in the Netherlands: Tcri01 in the east and Tcri02 in the south (fig. 1). A few additional haplotypes, differing by a single substitution, are found locally and at low frequency (figs. 1 and 2). Outside of the Netherlands, Tcri01 occurs across a vast part of the postglacially colonized range of *T. cristatus*, from the UK in the west to Russia in the east, as well as in a large part of Romania, a main glacial refugium of *T. cristatus* (Wielstra et al., 2015; Wielstra et al., 2017b; fig. 1). Tcri02 is only found in an area that is presumed to have been colonized postglacially, and further south than Tcri01, covering a large range across France, southern Germany and Austria (Meilink et al., 2015; Wielstra et al., 2015; Wielstra et al., 2017b; Fahrbach et al., 2021; fig. 1). The phylogeographical pattern we observe suggests postglacial recolonization of the Netherlands by *T. cristatus* via two distinct routes, from the south and from the east. A biogeographical scenario of expansion into western Europe via multiple routes, eventually converging in secondary contact, has been observed in multiple taxa (Hewitt, 1999).

An intriguing observation is the presence of haplotype Tcri17 in a single individual from one of the Belgian localities studied. This haplotype has previously been reported from a

single individual from north-western Romania (fig. 1; Wielstra et al., 2015). This could indicate an introduction history, but denser sampling in the intermittent area is required to exclude the possibility that this rare haplotype was spread via allele surfing (Klopfstein et al., 2006).

We did not obtain positive evidence for an anthropogenic origin of the Dutch coastal dune crested newt population. We observe the haplotype that is naturally distributed in the south of the Netherlands (Tcri02). The closest sampled native population is positioned c. 60 kilometres away and also contains haplotype Tcri02. Therefore, based on the mtDNA data, we cannot exclude the possibility that the Dutch coastal dune population is a distribution relict of a formerly larger range, cut off via extinction in the area in between due to habitat degradation (Griffiths and Williams, 2000; Karlsson et al., 2007). Such a scenario has been hypothesized to explain the presence of isolated northern crested newt populations in the Highlands of Scotland (O'Brien and Hall, 2012). A study using a variable nuclear DNA marker system, such as RAD-sequencing, could potentially shed more light on the origin of the Dutch coastal dune population (see e.g., Arntzen et al., 2010).

We did not find evidence for genetic admixture between *T. cristatus* and the invasive Italian crested newt *T. carnifex* in the Dutch coastal dunes. This is also the case for all other Dutch crested newts screened, except for a single individual sampled from the southside of the city of Breda. This individual possesses *T. cristatus* mtDNA (haplotype Tcri02) and is predominantly *T. cristatus* from the nuclear perspective, but contains multiple *T. carnifex* alleles as well. Indeed, an eDNA study found both *T. carnifex* and *T. cristatus* mtDNA to be present in a garden pond situated c. 200 metres away (Lambrixx and Spitzen-van der Sluijs, 2019). We can now confirm that hybridization between the two species is taking place here.

This is a second case of genetic admixture between *T. cristatus* and *T. carnifex* in the Netherlands (next to a large number of localities in the Veluwe area; Meilink et al., 2015; Wielstra et al., 2016). Many cases of ‘anthropogenic hybridization’ involving the release of *T. carnifex* into the native range of *T. cristatus* have now been documented (Brede et al., 2000; Arntzen, 2001; Maletzky et al., 2008; Brede, 2015; Dufresnes et al., 2016; Dufresnes et al., 2019; Hinneberg et al., 2022). The closest natural populations around Breda are only a few kilometres away (Lambrixx and Spitzen-van der Sluijs, 2019). We suggest this situation should be closely monitored and action to prevent the spread of *T. carnifex* genes should be taken as soon as possible, by removal of pure *T. carnifex* and genetically admixed individuals.

**Acknowledgements.** Jöran Janse, Jesper Berndsen, Ben Geutskens, Job Stumpel, Wouter Schuitema, Joey Braat and Ingrid den Boer provided samples from across the Netherlands. Belgium DNA extractions were provided by the Research Institute for Nature and Forest (INBO). Noël Aerts provided valuable insight on *Triturus* distribution in the dunes. Dunea allowed us to conduct fieldwork in Meijndel and Gemeente Den Haag in Westduinpark. The permit (no. FF/75A/2016/015) to conduct our fieldwork was provided via Reptile, Amphibian and Fish Conservation Netherlands (RAVON). Rolf van Leeningen provided the rough distribution outline in the Netherlands.

**Supplementary material.** Supplementary material is available online at:  
<https://doi.org/10.6084/m9.figshare.21214067>

## References

- Arntzen, J.W., Wallis, G.P. (1991): Restricted gene flow in a moving hybrid zone of the newts *Triturus cristatus* and *T. marmoratus* in western France. *Evolution* **45**: 805-826.
- Arntzen, J.W. (2001): Genetic variation in the Italian crested newt, *Triturus carnifex*, and the origin of a non-native population north of the Alps. *Biodivers. Conserv.* **10**: 971-987.
- Arntzen, J.W., Burke, T., Jehle, R. (2010): Estimating the propagule size of a cryptogenic crested newt population. *Anim. Conserv.* **13**: 74-81.
- Arntzen, J.W., King, T.M., Denoël, M., Martínez-Solano, I., Wallis, G.P. (2016): Provenance of *Ichthyosaura alpestris* (Caudata: Salamandridae) introductions to France and New Zealand assessed by mitochondrial DNA analysis. *Herpetol. J.* **26**: 49-56.
- Bergmans, W., Zuiderwijk, A. (1986): Atlas van de Nederlandse Amfibieën en Reptielen Hoogwoud. KNNV.
- Bogaerts, S. (2002): Italian crested newts, *Triturus carnifex*, on the Veluwe, Netherlands. *Z. Feldherpetol.* **9**: 217-226.
- Brede, E.G., Thorpe, R.S., Arntzen, J.W., Langton, T.E.S. (2000): A morphometric study of a hybrid newt population (*Triturus cristatus/T. carnifex*): Beam Brook Nurseries, Surrey, U.K. *Biol. J. Linn. Soc.* **70**: 685-695.
- Brede, E.G. (2015): Beam Brook revisited: a molecular study of a historically introduced non-native amphibian (*Triturus carnifex*) and its limited introgression into native UK *Triturus cristatus* populations. *Amphib.-Reptil.* **36**: 287-299.
- Chiocchio, A., Biscconti, R., Zampiglia, M., Nascetti, G., Canestrelli, D. (2017): Quaternary history, population genetic structure and diversity of the cold-adapted Alpine newt *Ichthyosaura alpestris* in Peninsular Italy. *Sci. Rep.* **7**: 2955.
- Clement, M., Posada, D., Crandall, K.A. (2000): TCS: a computer program to estimate gene genealogies. *Mol. Ecol.* **9**: 1657-1659.
- Creemers, R., van Delft, J.J.C.W. (2009): De amfibieën en reptielen van Nederland. In: Nederlandse Fauna 9, Nationaal Natuurhistorisch Museum Naturalis & European Invertebrate Survey, Leiden.
- Darriba, D., Taboada, G.L., Doallo, R., Posada, D. (2012): jModelTest 2: more models, new heuristics and parallel computing. *Nat. Methods* **9**: 772-772.
- Dufresnes, C., Pellet, J., Bettinelli-Riccardi, S., Thiébaud, J., Perrin, N., Fumagalli, L. (2016): Massive genetic introgression in threatened northern crested newts (*Triturus cristatus*) by an invasive congener (*T. carnifex*) in western Switzerland. *Conserv. Genet.* **17**: 839-846.
- Dufresnes, C., Déjean, T., Zumbach, S., Schmidt, B.R., Fumagalli, L., Ramseier, P., Dubey, S. (2019): Early detection and spatial monitoring of an emerging biological invasion by population genetics and environmental DNA metabarcoding. *Conserv. Sci. Pract.* **1**: e86.
- Fahrbach, M., de Visser, M.C., Wielstra, B. (2021): The hybrid zone between the Italian and northern crested newts (*Triturus carnifex* and *T. cristatus*) reaches Germany. *Salamandra* **57**: 428-434.
- Griffiths, R.A., Williams, C. (2000): Modelling population dynamics of great crested newts (*Triturus cristatus*): a population viability analysis. *Herpetol. J.* **10**: 157-163.
- Haubrock, P., Altrichter, J. (2017): Northern crested newt (*Triturus cristatus*) migration in a nature reserve: multiple incidents of breeding season displacements exceeding 1 km. *Herpetol. Bull.*: 31-33.
- Hebert, P.D.N., Cywinska, A., Ball, S.L., deWaard, J.R. (2003): Biological identifications through DNA barcodes. *P. R. Soc. Lond. B.* **270**: 313-321.
- Hewitt, G.M. (1999): Post-glacial re-colonization of European biota. *Biol. J. Linn. Soc.* **68**: 87-112.

- Hinneberg, H., Bamann, T., Geue, J.C., Foerster, K., Thomassen, H.A., Kupfer, A. (2022): Truly invasive or simply non-native? Insights from an artificial crested newt hybrid zone. *Conserv. Sci. Pract.*: e12752.
- Karlsson, T., Betzholtz, P.E., Malmgren, J.C. (2007): Estimating viability and sensitivity of the great crested newt *Triturus cristatus* at a regional scale. *Web Ecol.* **7**: 63-76.
- Klopfstein, S., Currat, M., Excoffier, L. (2006): The fate of mutations surfing on the wave of a range expansion. *Mol. Biol. Evol.* **23**: 482-490.
- Kuijt, M., Oskam, L., den Boer, I., Dufresnes, C., France, J., Gilbert, M., de Visser, M., Struijk, R.P.J.H., Wielstra, B. (2023): The introduction of three cryptic tree frog species in the Dutch coastal dunes challenges conservation paradigms. *Amphib.-Reptil.*, this issue.
- Kupfer, A., Kneitz, S. (2000): Population ecology of the great crested newt (*Triturus cristatus*) in an agricultural landscape: dynamics, pond fidelity and dispersal. *Herpetol. J.* **10**: 165-171.
- Lambrikk, N., Spitzzen-van der Sluijs, A. (2019): Inventarisatie Kamsalamander. Baronielaan, Breda. Stichting RAVON, Nijmegen.
- Mačat, Z., Rulík, M., Jablonski, D., Reiter, A., Jeřábková, L., Rada, S., Mikulíček, P. (2019): Species-specific habitat preferences do not shape the structure of a crested newt hybrid zone (*Triturus cristatus* x *T. carnifex*). *Ecol. Evol.* **9**: 12446-12458.
- Maletzky, A., Mikulíček, P., Franzen, M., Goldschmid, A., Gruber, H.-J., Horák, A., Kyek, M. (2008): Hybridization and introgression between two species of crested newts (*Triturus cristatus* and *T. carnifex*) along contact zones in Germany and Austria: morphological and molecular data. *Herpetol. J.* **18**: 1-15.
- Maletzky, A., Kaiser, R., Mikulíček, P. (2010): Conservation genetics of crested newt species *Triturus cristatus* and *T. carnifex* within a contact zone in central Europe: impact of interspecific introgression and gene flow. *Diversity* **2**: 28-46.
- Meilink, W.R.M., Arntzen, J.W., van Delft, J.J.C.W., Wielstra, B. (2015): Genetic pollution of a threatened native crested newt species through hybridization with an invasive congener in the Netherlands. *Biol. Conserv.* **184**: 145-153.
- Mikulíček, P., Horák, A., Zavadil, V., Kautman, J., Piálek, J. (2012): Hybridization between three crested newt species (*Triturus cristatus* superspecies) in the Czech Republic and Slovakia: comparison of nuclear markers and mitochondrial DNA. *Folia Zool.* **61**: 202-218.
- Mir, R.A., Bhat, K.A., Rashid, G., Ebinezer, L.B., Masi, A., Rakwal, R., Shah, A.A., Zargar, S.M. (2021): DNA barcoding: a way forward to obtain deep insights about the realistic diversity of living organisms. *The Nucleus* **64**: 157-165.
- Múrias dos Santos, A., Cabezas, M.P., Tavares, A.I., Xavier, R., Branco, M. (2015): tcsBU: a tool to extend TCS network layout and visualization. *Bioinformatics* **32**: 627-628.
- O'Brien, D., Hall, J. (2012): A hypothesis to explain the distribution of great crested newt *Triturus cristatus* in the highlands of Scotland. *Herpetol. Bull.* **119**: 9-14.
- Pabijan, M., Rozej, E., Bonk, M. (2009): An isolated locality of the Alpine newt (*Mesotriton alpestris* Laurenti, 1768) in central Poland. *Herpetology Notes* **2**: 23-26.
- Rambaut, A., Drummond, A.J., Xie, D., Baele, G., Suchard, M.A. (2018): Posterior summarization in Bayesian phylogenetics using Tracer 1.7. *Syst. Biol.*: 901-904.
- Ronquist, F., Teslenko, M., van der Mark, P., Ayres, D.L., Darling, A., Höhna, S., Larget, B., Liu, L., Suchard, M.A., Huelsenbeck, J.P. (2012): MrBayes 3.2: efficient Bayesian phylogenetic inference and model choice across a large model space. *Syst. Biol.* **61**: 539-542.
- Sambrook, J., Russell, D.W. (2001): *Molecular Cloning: a Laboratory Manual* 3rd Edition. ColdSpring-Harbour. Laboratory Press, UK.
- Semagn, K., Babu, R., Hearne, S., Olsen, M. (2014): Single nucleotide polymorphism genotyping using Kompetitive Allele Specific PCR (KASP): overview of the technology and its application in crop improvement. *Mol. Breed.* **33**: 1-14.
- Simberloff, D. (2013): *Invasive Species: What Everyone Needs to Know*. Oxford University Press.
- Tingley, R., Weeks, A.R., Smart, A.S., van Rooyen, A.R., Woolnough, A.P., McCarthy, M.A. (2015): European newts establish in Australia, marking the arrival of a new amphibian order. *Biol. Invasions* **17**: 31-37.
- Unglaub, B., Cayuela, H., Schmidt, B.R., Preißler, K., Glos, J., Steinfartz, S. (2021): Context-dependent dispersal determines relatedness and genetic structure in a patchy amphibian population. *Mol. Ecol.* **30**: 5009-5028.
- Villesen, P. (2007): FaBox: an online toolbox for fasta sequences. *Mol. Ecol. Notes* **7**: 965-968.
- Vliegenthart, C., van de Vrede, M., den Boer, I., Gilbert, M., Lemmers, P., France, J., de Visser, M., Struijk, R.P.J.H., Wielstra, B. (2023): The limits of mtDNA analysis for determining the provenance of invasive species: a midwife toad example. *Amphib.-Reptil.*, this issue.
- Wanders, R. (2002): Kamsalamander na 30 jaar nog steeds in Meijndel. *Holland's Duinen*: 24-26.
- Wielstra, B., Crnobrnja-Isailović, J., Litvinchuk, S.N., Reijnen, B.T., Skidmore, A.K., Sotiropoulos, K., Toxopeus, A.G., Tzankov, N., Vukov, T., Arntzen, J.W. (2013): Tracing glacial refugia of *Triturus* newts based on mitochondrial DNA phylogeography and species distribution modeling. *Front. Zool.* **10**: 13.
- Wielstra, B., Sillero, N., Vörös, J., Arntzen, J.W. (2014): The distribution of the crested and marbled newt species (Amphibia: Salamandridae: *Triturus*) – an addition to the New Atlas of Amphibians and Reptiles of Europe. *Amphib.-Reptil.* **35**: 376-381.
- Wielstra, B., Babik, W., Arntzen, J.W. (2015): The crested newt *Triturus cristatus* recolonized temperate Eurasia from an extra-Mediterranean glacial refugium. *Biol. J. Linn. Soc.* **114**: 574-587.
- Wielstra, B., Burke, T., Butlin, R.K., Schaap, O., Shaffer, H.B., Vrieling, K., Arntzen, J.W. (2016): Efficient screening for 'genetic pollution' in an anthropogenic crested newt hybrid zone. *Conserv. Genet. Resour.* **8**: 553-560.



- Wielstra, B., Burke, T., Butlin, R.K., Arntzen, J.W. (2017a): A signature of dynamic biogeography: enclaves indicate past species replacement. *Proc. Royal Soc. B* **284**: 20172014.
- Wielstra, B., Zięliński, P., Babik, W. (2017b): The Carpathians hosted extra-Mediterranean refugia-within-refugia during the Pleistocene Ice Age: genomic evidence from two newt genera. *Biol. J. Linn. Soc. Lond.* **122**: 605-613.
- Wilson, R.J., Thomas, C.D., Fox, R., Roy, D.B., Kunin, W.E. (2004): Spatial patterns in species distributions reveal biodiversity change. *Nature* **432**: 393-396.