



Universiteit
Leiden

The Netherlands

Bone and joint disorders: screening and early clinical drug development

Vrouwe, J.P.M.

Citation

Vrouwe, J. P. M. (2022, December 7). *Bone and joint disorders: screening and early clinical drug development*. Retrieved from <https://hdl.handle.net/1887/3503538>

Version: Publisher's Version

License: [Licence agreement concerning inclusion of doctoral thesis in the Institutional Repository of the University of Leiden](#)

Downloaded from: <https://hdl.handle.net/1887/3503538>

Note: To cite this publication please use the final published version (if applicable).

**BONE AND JOINT DISORDERS:
SCREENING AND EARLY CLINICAL
DRUG DEVELOPMENT**

J.P.M. Vrouwe

BONE AND JOINT DISORDERS: SCREENING AND EARLY CLINICAL DRUG DEVELOPMENT

Proefschrift

ter verkrijging van
de graad van doctor aan de Universiteit Leiden,
op gezag van rector magnificus prof.dr.ir. H. Bijl,
volgens besluit van het college voor promoties
te verdedigen op woensdag 7 december 2022
klokke 10:00 uur

DOOR
Josephina Petronella Maria van Alphen-Vrouwe
geboren te Amsterdam
in 1989

Design

Caroline de Lint, Den Haag (caro@delint.nl)

*The publication of this thesis was financially supported by the foundation
Centre for Human Drug Research (CHDR) in Leiden The Netherlands*

Promotores:

Prof. dr. J. Burggraaf

Prof. dr. S. Osanto

Co-promotor:

I.M.C. de Visser-Kamerling

Leescommissie:

Prof. dr. R.C.M. Pelger, *Leiden University Medical Center*

Prof. dr. J.A. Gietema, *University Medical Center Groningen*

Prof. dr. C.W.G.M. Lowik, *Erasmus Medical Center*

Prof. dr. M. Hazes, *Erasmus Medical Center*

8 **CHAPTER 1** Introduction

SECTION I – BONE IN MALE UROLOGICAL MALIGNANCIES

24 **CHAPTER 2** Risk of osteoporosis in testicular germ cell tumor survivors: a systematic review of the literature

56 **CHAPTER 3** Quantitative ultrasound of the calcaneus (QUS): a valuable tool in the identification of patients with non-metastatic prostate cancer requiring screening for osteoporosis

76 **CHAPTER 4** An exploratory first-in-man study to investigate the pharmacokinetics and safety of liposomal dexamethasone at a 2- and 1-week interval in patients with metastatic castration resistant prostate cancer

SECTION II – OSTEOARTHRITIS THERAPIES

98 **CHAPTER 5** Challenges and opportunities of pharmacological interventions for osteoarthritis: a review of clinical trials and current developments

126 **CHAPTER 6** Safety, tolerability, PK and PD of single ascending doses of LRX712 in knee osteoarthritic patients: a randomized placebo-controlled phase I trial

142 **CHAPTER 7** Administration of an adeno-associated viral vector expressing interferon- β in patients with inflammatory hand arthritis, results of a phase I/II study

162 **CHAPTER 8** General discussion

174 Summary

180 Nederlandse Samenvatting

187 Curriculum Vitae

189 Publications

191 Dankwoord

CHAPTER 1

Introduction

The skeleton offers support, shape and protection to organs and surrounding soft tissues. With the joints, it provides a framework for muscles and nerves to maintain posture and control movement. Beside this mechanical function, it has other important roles, particularly in calcium-phosphate homeostasis and hematopoiesis.^{1,2} As hematopoiesis is not a primary subject of this thesis, it will not be discussed in this introduction.

Bone

CONSTRUCTION AND METABOLISM

Skeletal formation in humans is initiated in the first 2-3 months of the fetal development. Two types of osseous formation can be distinguished: (1) endochondral ossification, development by differentiation of mesenchyme into cartilage that is gradually replaced by bone leading to long bones that compile limbs and spine, and (2) intramembranous ossification, in which mesenchyme condenses to a thick membrane that slowly mineralizes resulting in flat bones such as the skull, mandible and clavicles.

Throughout life, bone is modeled by osteoclasts, governed by hormonal and mechanical influences (stress and strain). Bone formation during life is supplied by osteoblasts in the periosteum.¹⁻³

The main chemical component of bone is hydroxyapatite ($\text{Ca}_{10}(\text{PO}_4)_6(\text{OH})_2$) that, as the other components of bone, is subject to capture or release by the continuous processes of bone formation and breakdown. As such, bone is a highly metabolic active organ: approximately 10-15% of bone is renewed each year in adults.² This turn-over enables the bone to contribute to the calcium- and phosphate homeostasis.

The calcium – parathyroid hormone (PTH) – vitamin D axis plays the pivotal role in physiological bone- and calcium/phosphate homeostasis: the blood calcium concentration exerts negative feedback to PTH production and secretion. PTH increases renal calcium reabsorption and osteoclastic bone resorption; as such, hypocalcemia is compensated from sources available within the body.⁴ In addition, the active metabolite of vitamin D, calcitriol, induces calcium absorption from the gut.⁵ Thus, calcium- and/or vitamin D deficiency may lead to hyperparathyroidism and osteoporosis.^{4,5}

Another role in bone homeostasis relates to gonadal hormones: estrogens and androgens. The importance of estrogens in bone homeostasis is demonstrated by their role in the etiology of post-menopausal osteoporosis. Androgens (predominantly testosterone), also have an important role

in bone homeostasis. They contribute to the achievement of a higher peak bone mass in males than in females, in adolescence.⁶⁻⁹ Physiologically, serum concentrations of sex hormones change with age in both men and women.¹⁰ The most abrupt change occurs in women, in the menopause transition. At menopause a relatively abrupt decrease of total estradiol and increase of follicle stimulating hormone (FSH) occurs.¹⁰ In men, androstereone-precursor dehydroepiandrosterone sulfate levels (and thereby testosterone) gradually decrease- and FSH increases with age.¹¹ As a result of these hormonal changes, bone mineral density (BMD) decreases with age in both sexes.¹²

OSTEOPOROSIS

Osteoporosis is defined by the world health organization as a BMD T-score < -2.5, i.e. measured BMD more than 2.5 standard deviations below the average of a reference population of young Caucasian women.¹³ The current gold standard for measurement of BMD is dual energy X-ray absorptiometry (DXA).¹³ Low BMD increases the risk of nontraumatic or low-energetic fractures and associated morbidity and mortality.^{14,15}

The complications of low BMD may be avoided by implementation of screening to enable early diagnosis and treatment. A strategy for early detection could include standardized screening of patients at risk of developing osteoporosis. Subsequently, osteoporosis and associated fragility fractures may be prevented by timely adjustments in bone-deteriorating therapy, hormone replacement, osteopenia- and osteoporosis treatment with bisphosphonates and calcium regulating compounds.¹⁶⁻¹⁸

Conditions which influence BMD include endocrine- and metabolic diseases such as adrenal insufficiency, Cushing syndrome, hyperparathyroidism, hypogonadism and type I diabetes mellitus.¹⁹ Furthermore, changes in gonadal hormones may be induced by pharmacotherapy, e.g. glucocorticoids, estrogen modulators and androgen deprivation therapy.¹⁹

Urogenital malignancies may also harm BMD. In case of testicular germ cell tumors, a negative effect has not been unequivocally demonstrated yet. These tumors may affect the BMD through the simultaneous presence of a hypogonadal state, as testicular dysgenesis, and associated Leydig cell dysfunction is more prevalent among these patients. In addition, testicular germ cell tumors are treated by orchiectomy, often combined with chemotherapy. Both treatment modalities influence the gonadal state and chemotherapy has an independent negative effect on BMD.^{20,21}

Prostate cancer treatment often involves multiple years of androgen deprivation therapy, which subsequently leads to enhanced risk of low BMD.²² This risk of low BMD is recognized in this population and screening and treatment is advised by several guidelines.^{23,24}

BONE TUMORS- AND METASTASES

Bone lesions, benign and malignant, are another cause of skeletal fragility. Primary bone tumors are relatively rare,²⁵ but the skeleton is a preferred location for metastases from several primary solid organ tumors such as prostate- breast- lung- and renal cancer.²⁶⁻²⁸ According to the seed and soil theory, malignant cells can colonize another organ only if the microenvironment is conducive to their implantation.²⁹

A preparatory process of the 'soil' (pre-metastatic site) finds place before cells from the primary tumor can settle. It implies the induction of an inflammatory state, that makes circulating tumor cells admissible for settlement, growth in the tissue and thereby development of metastases. The induction of such an inflammatory state occurs via signaling through exosomes excreted by a primary tumor. Integrins expressed on the surface of the exosomes condition tropism to organs located at a distance (i.e. the preferred metastatic sites). There, they are internalized and initiate the inflammatory state by activation of chemokines.^{30,31} Circulating tumor cells are directed by chemokine gradients and – in case of bone metastases – cytokine receptor activator of nuclear factor kappa-B ligand (RANKL), which makes the prepared inflammatory sites ideal targets for settling.^{26,31,32}

As chemokines are tissue specific, the overlap between expression of chemokine subtypes in the targeted tissues and chemokine subtype receptors on circulating tumor cells is decisive for the preferred sites for metastases of a certain tumor type. Finally, a complex interplay of matrix proteins, lysyl oxidases, proteases and micro-RNA's enables further tumor cell invasion- and survival of the intruding cells at the metastatic site.³⁰ In case of bone, the growth of metastases causes pain, local weakening of the bone, and thereby fracture risk.

Metastatic sites have tissue-specific properties that most other tissues do not have (e.g. state of inflammation, high metabolism, modified vascular structure). By the time a solid tumor measures 2-3 mm, angiogenesis is induced.³³ Tumor neovasculature differs from that of normal tissue, presenting dilated, leaky and irregular of shape.³³ These malformations allow

extravasation of large particles (macromolecules, nanoparticles, lipidic particles) into the tissue. Once absorbed into the tissue, the particles are retained longer than in other tissue due to poor lymph drainage. This phenomenon is the 'enhanced permeability and retention effect'.³⁴

Anti-cancer treatments may take advantage of this effect to enable tumor targeting. If a relatively large proportion of the administered (often toxic) dose is available at the target sites, that may result in a better response, whilst limiting systemic side effects. A such, targeting may result in a longer survival and preservation of quality of life.

The preferred methods for diagnosis and follow-up of bone metastases in case of a known underlying malignancy, are skeletal scintigraphy and (positron emission tomography)-computed tomography (PET)-CT scan.^{35,36} Fluodeoxyglucose (FDG) PET imaging utilizes the high metabolism in the tumor sites, to visualize tumor sites. The tumor takes up most (radioactive) glucose, which can be detected and converted to an image by the PET-scanner.

Joint

Synovial joints are essential for mobility. In addition to the osseous epiphyses, joints consist of cartilage, synovium, synovial fluid and in some cases menisci and ligaments. Inflammatory joint disease is the most common cause of joint disorder induced movement impairment, primarily due to the prevalence of osteoarthritis (OA).^{37,38} Many joint pathologies are left undiscussed here, as those are not subject of this thesis.

OSTEOARTHRITIS

Although highly prevalent, the exact etiology of OA remains largely unknown. It was long thought that OA was caused by 'wear and tear' of the cartilage, but current insights add other important factors. OA is now known as a multifactorial and highly heterogeneous disease, risk factors for which include: a history of traumatic joint injury, obesity, aging, biomechanical factors, and hereditary factors.^{39,40}

Multiple joint tissues are involved in osteoarthritis: cartilage was long thought to play the primary role, as it is non-vascularized and the supply of nutrients and oxygen to the chondrocytes is restricted, and repair is hindered, all resulting in cartilage degeneration. Although the cartilage may be damaged in an OA-affected joint, it is an aneural tissue, and pain only

appears if innervated tissues are involved.⁴¹ Synovium and subchondral bone are now also recognized to be involved in osteoarthritis from an early stage on.⁴¹⁻⁴³ Inflamed synovium produces catabolic and pro-inflammatory mediators, which can alter the balance within the cartilage matrix and thereby advance OA.⁴⁴

Standard radiography is commonly used to confirm OA but is inadequate to detect early OA-related changes in the joints, and its correlation with clinical symptoms in early OA is poor.⁴⁵⁻⁴⁸ Synovitis and subchondral bone activity cause early clinical symptoms such as joint swelling and pain but are not identifiable on standard radiographs. Synovitis can be identified by ultrasound and magnetic resonance imaging. Subchondral bone activity/turnover is apparent on magnetic resonance images as subchondral bone lesions.^{41,44}

CURRENT TREATMENTS

Current treatments for OA are restricted to symptom relief by minimization of pain and optimization of joint function. Various non-pharmacological and pharmacological interventions are available, all with only modest effects. Therefore, a combination of therapeutic approaches is commonly used. The choice of interventions is based on individual factors such as affected joints, disease extensiveness (mono-, oligo-, or poly-arthritis), and severity of symptoms, in addition to the presence of concurrent signs and symptoms such as muscle weakness, comorbidities, obesity, functional impairment, and depression.⁴⁹⁻⁵² Initially, non-pharmacological interventions such as exercise, weight loss, education and self-management programs are strongly recommended for all types of OA.⁵⁰ The next therapeutic step consists of pharmacological interventions, among which are: analgesic treatment, including oral and topical non-steroidal anti-inflammatory drugs (NSAIDs; selective and non-selective COX-2), paracetamol, tramadol, duloxetine, chondroitin, intra-articular steroid administration and topical capsaicin.⁵⁰

The approved pharmacological interventions for OA treatment target symptoms and have no meaningful disease modifying effect. As a result, the condition worsens over time and in some cases leads to arthroplasty. Total hip- or knee replacement results in pain reduction in the majority of patients and their cost-effectiveness is well established.^{53,54} Unfortunately, these surgical interventions for OA are commonly preceded by a long trajectory of pain and functional limitation. Also, the interventions are not successful for

all patients and there is a risk of complications during the post-surgical trajectory, e.g. thromboembolic events or infection.⁵⁵⁻⁵⁷

It is plausible to assume that the increasing knowledge of the pathophysiology of OA will result in the identification of novel pathways/targets that can be exploited to develop disease modifying OA drugs (DMOADs). The involved tissues (synovium, subchondral bone, and cartilage) may each be targeted by potential DMOADs.

Cartilage regeneration may still give an effect; cartilage degeneration remains a key factor in OA and -especially in traumatic OA-, it influences joint loading and may enhance further joint degeneration. The growth of cartilage is a challenge, as the tissue is so poorly vascularized. Approaches to achieve this growth could be stimulation of cartilage stem progenitor cells, or the introduction of stem cells into the joint. So far, no pharmacotherapeutics have been registered in this class.

As inflamed synovium expresses mediators which further stimulate degenerative changes in OA,^{41,42} muting synovitis may be a successful treatment strategy. So far, systemic- and local therapies with a general anti-inflammatory mechanism (corticosteroids) and disease modifying antirheumatic drugs, were unsuccessful.^{58,59} At least two explanations for which may be applicable: the mechanism of action does not have the desired effect, or the exposure in the synovium was not sufficient to be effective.

Several attempts have been done to target the subchondral bone with therapies registered for other indications, but so far without success.^{16,60}

When successful, DMOADs would lead to quality-of-life improvement.⁶¹ This will, however, be a *bumpy road* as shown by the failed attempts to develop DMOADs so far. It is important to identify the reasons for these failures and in particular address possibly erroneous assumptions in animal-to-human translation, side effects, structural symptom discordance, incorrect structural endpoints.⁶²⁻⁶⁶

Epidemiology

The personal- and societal burden caused by disorders affecting the bone and joints is significant – grouped musculoskeletal disorders rank as the most expensive category in healthcare expenses in the USA, with annual costs of \$380.9 billion.⁶⁷

Societal costs of osteoporosis fractures are \$17.9 billion per annum in the USA.⁶⁸ Approximately 25% of osteoporosis-related healthcare cost, is on ac-

count of men.⁶⁹ Although long neglected, increasing attention is being paid to osteoporosis in men, and the Endocrine society guideline recommends screening of men at risk.⁷⁰

Prostate cancer patients, particularly those undergoing androgen deprivation therapy, are known to be at risk for fractures, due to their state of pharmacologically induced hypogonadism.⁷¹ Prostate cancer mostly occurs in men >65 years of age and is the second most diagnosed type of cancer in males worldwide, with 1.5 million newly diagnosed- and 0.4 million deaths per year.^{25,72} Screening and treatment of prostate cancer patients for osteoporosis could prevent skeletal related events (fragility fractures), and thereby reduce personal- and societal burden. Although screening for osteoporosis in patients using ADT is widely recommended,⁷³⁻⁷⁶ it is scarcely implemented.⁷⁷⁻⁷⁹ The application of DXA in all these patients is costly and time consuming; a more efficient approach of screening may be available and preferable.^{25,80}

In contrast to the highly prevalent prostate cancer, testicular carcinoma is globally diagnosed in approximately 75 000 men per year and has an estimated mortality of ~10 000 per year.^{72,81} Although not as prevalent, the mean age at diagnosis of testicular cancer is generally much lower than that of prostate cancer patients. In fact, testicular cancer is the most common type of cancer in men aged 18-40 years.⁸¹ Curative rates for testicular cancer are high, thereby, these young men have longstanding consequences of late effects of testicular cancer, such as hypogonadism- cardiovascular disease or osteoporosis. The effects of testicular cancer to bone health are not as well-established as those of prostate cancer; screening for osteoporosis is not recommended in the European agency for urology (EAU) guideline for testicular cancer,⁸² while the Endocrine society recommends screening of hypogonadal patients,⁸³ which testicular cancer survivors frequently are.⁸⁴

OA is one of the largest contributors to healthcare cost due to musculoskeletal disorders.⁶⁷ Incidence of OA increases with age; globally 10% of men and 18% of women aged over 60 years have symptomatic OA.^{37,38} OA leads to annual healthcare expenses of approximately \$80.0 billion in the USA.⁶⁷ As such, it is a cause of long-term pain and disability in older adults, causing loss of work productivity and significant healthcare- and social support costs. Development of a DMOAD has the potential to relieve some of these costs.

In conclusion

Musculoskeletal disorders have an enormous personal- and societal impact. Diagnosis and treatment of these disorders are most efficient if targeted screening, accurate diagnosis, and targeted treatment are available. To enable targeted screening, the population at risk must be well-defined and categorized if required. Subsequently, screening- and diagnostic methods must have good, or excellent predictive value and finally, treatment must target the disease, thus spare healthy tissues and processes and thereby avoid adverse events.

The aim of this thesis is to gain new insights about the diagnostic process- and treatment of pathological conditions of the bone and joints, namely male urological cancer-induced bone loss and OA.

This thesis

This thesis consists of two sections; In Section I, screening, diagnosis and treatment of the consequences of male urological malignancies and their therapies to bone health are investigated (**Chapters 2-4**). Section II focuses on inflammatory arthritis and the early clinical development of compounds targeting inflammatory joint disease (**Chapters 5-7**).

SECTION I: BONE IN MALE UROLOGICAL MALIGNANCIES

In this thesis, the vulnerability of the skeleton is studied in the context of two male urological malignancies: prostate cancer and testicular cancer. In both cancers a role is assigned to (treatment induced) hypogonadism, which could cause a low BMD, and secondary effects from anti-cancer therapy (androgen deprivation therapy, chemotherapy, corticosteroids). In prostate cancer osseous metastasis further contribute to detrimental skeletal effects. In this thesis, it was aimed to investigate options of strategic screening and early diagnosis of osteoporosis and targeted treatment of osseous metastases.

Chapter 2 of describes a literature review of the effects of testicular cancer and its treatments on BMD, as measured in dual-energy x-ray absorptiometry (DXA), and outcomes of hormone levels and bone turnover markers that were reported in the investigated populations. Prostate cancer patients are at risk of having poor bone health due to years of androgen deprivation therapy. In addition to DXA, quantitative ultrasound (QUS) is another,

more accessible, method to evaluate BMD and bone structure, which can be applied directly in the clinic. However, it is not as frequently applied nor as well-established as DXA. A study for the accuracy and potential of QUS as a pre-screening tool in prostate cancer patients, is presented in **Chapter 3**. **Chapter 4** reports the results of a first-in-human clinical study in which patients with metastatic castration resistant prostate cancer with osseous metastases were included. The liposomal compound that was administered in this study, was designed to target osseous metastatic sites. The aims of the study were to investigate safety and tolerability and to explore efficacy.

SECTION II: OSTEOARTHRITIS THERAPIES

The current pipeline of treatment advances in OA is described in a clinical trial database review in **Chapter 5**. One of the categories in which clinical trials are ongoing, is cartilage metabolism. **Chapter 6** describes the first-in-human study of a chondro-stimulating compound (LRX712). The compound was administered to patients with knee osteoarthritis. **Chapter 7** describes the outcomes of a first-in-human study with ART-102. This gene-therapy product aims to give inflammation-driven expression of an anti-inflammatory protein in the synovium, to inhibit the low-grade inflammatory state in the joint, and in the synovium in particular. In this study ART-102 was introduced into a target hand joint of patients with inflammatory hand arthritis. The main objectives of the studies in **Chapters 6 and 7**, were to establish safety and tolerability of the compounds, and to explore efficacy.

A summary, general discussion and conclusions of the thesis are described in **Chapter 8**, and a summary conclusion in Dutch is given in **Chapter 9**.

REFERENCES

- Verhaar JAN, van Mourik JBA. *Orthopedie*. Bohn Stafleu van Loghum; 2008.
- Steele DG, Bramblett CA. *The Anatomy and Biology of the Human Skeleton*.; 1988.
- Moore K, Peraud T, Torchia M. *The Developing Human*.; 2020.
- Goltzman D, Mannstadt M, Marcocci C. Physiology of the Calcium-Parathyroid Hormone-Vitamin D Axis. *Frontiers of Hormone Research*. 2018;50:1-13. doi:10.1159/000486060
- Lips P, Van Schoor NM. The effect of vitamin D on bone and osteoporosis. *Best Practice and Research: Clinical Endocrinology and Metabolism*. 2011;25(4):585-591. doi:10.1016/j.beem.2011.05.002
- Albright F. The effect of hormones on osteogenesis in man. *Rec Prog Horm Res*. 1947;1:293-353.
- Albright F, Bloomberg F, Smith P. Postmenopausal osteoporosis. *Trans Assoc Am Physicians*. 1940;55:298-305.
- Marcus R, Leary D, Schneider DL, Shane E, Favus M, Quigley CA. The contribution of testosterone to skeletal development and maintenance: Lessons from the androgen insensitivity syndrome. *Journal of Clinical Endocrinology and Metabolism*. 2000;85(3):1032-1037. doi:10.1210/jcem.85.3.6428
- Nicks KM, Fowler TW, Gaddy D. Reproductive hormones and bone. *Current Osteoporosis Reports*. 2010;8(2):60-67. doi:10.1007/s11914-010-0014-3
- Burger HG, Dudley EC, Hopper JL, et al. Prospectively Measured Levels of Serum Follicle-Stimulating Hormone, Estradiol, and the Dimeric Inhibins during the Menopausal Transition in a Population-Based Cohort of Women. *The Journal of Clinical Endocrinology & Metabolism*. 1999;84(11):4025-4030. doi:10.1210/jcem.84.11.6158
- Bjørnerem Å, Straume B, Midtby M, et al. Endogenous sex hormones in relation to age, sex, lifestyle factors, and chronic diseases in a general population: The Tromsø study. *Journal of Clinical Endocrinology and Metabolism*. 2004;89(12):6039-6047. doi:10.1210/jc.2004-0735
- Looker AC, Borrud LG, Hughes JP, Fan B, Shepherd JA, Melton LJ. Lumbar spine and proximal femur bone mineral density, bone mineral content, and bone area: United States, 2005-2008. *Vital and health statistics Series 11, Data from the national health survey*. 2012;(251):1-132.
- World Health Organization. WHO Scientific Group on the Assessment of Osteoporosis At Primary Health. *World Health Summary Meeting Report Brussels, Belgium, 2004*. 2007;May(May 2004):1-13.
- Center JR, Nguyen T V., Schneider D, Sambrook PN, Eisman JA. Mortality after all major types of osteoporotic fracture in men and women: An observational study. *Lancet*. 1999;353(9156):878-882. doi:10.1016/S0140-6736(98)09075-8
- Bliuc D, Center JR. Determinants of mortality risk following osteoporotic fractures. *Current Opinion in Rheumatology*. 2016;28(4):413-419. doi:10.1097/BOR.0000000000000300
- Cai G, Aitken D, Laslett LL, et al. Effect of Intravenous Zoledronic Acid on TibioFemoral Cartilage Volume among Patients with Knee Osteoarthritis with Bone Marrow Lesions: A Randomized Clinical Trial. *JAMA - Journal of the American Medical Association*. 2020;323(15):1456-1466. doi:10.1001/jama.2020.2938
- Liu M, Guo L, Pei Y, et al. Efficacy of zoledronic acid in treatment of osteoporosis in men and women—a meta-analysis. *International journal of clinical and experimental medicine*. 2015;8(3):3855-3861.
- Fizazi K, Carducci M, Smith M, et al. Denosumab versus zoledronic acid for treatment of bone metastases in men with castration-resistant prostate cancer: A randomised, double-blind study. *The Lancet*. 2011;377(9768):813-822. doi:10.1016/S0140-6736(10)62344-6
- US Department of Health and Human Services. Bone health and osteoporosis: a report of the Surgeon General. *US Health and Human Services*. Published online 2004:437.
- Bandak M, Jørgensen N, Juul A, et al. Testosterone deficiency in testicular cancer survivors – a systematic review and meta-analysis. *Andrology*. 2016;4(3):382-388. doi:10.1111/andr.12177
- Bandak M, Aksglaede L, Juul A, Rørth M, Daugaard G. The pituitary-Leydig cell axis before and after orchiectomy in patients with stage I testicular cancer. *European Journal of Cancer*. 2011;47(17):2585-2591. doi:10.1016/j.ejca.2011.05.026
- Badri el SAM, Salawu A, Brown JE. Bone Health in Men with Prostate Cancer: Review Article. *Curr Osteoporos Rep*. 2019;17(6):527-537. doi:10.1007/s11914-019-00536-8
- IKN. Prostaatcancer Landelijke richtlijn, Versie: 3.0.
- Cornford P, van den Bergh RCN, Briers E, et al. EAU-EANM-ESTRO-ESUR-SIOG Guidelines on Prostate Cancer. Part II—2020 Update: Treatment of Relapsing and Metastatic Prostate Cancer. *European Urology*. Published online 2020. doi:10.1016/j.eururo.2020.09.046
- Siegel RL, Miller KD, Jemal A. Cancer statistics, 2020. *CA Cancer J Clin*. 2020;70(1):7-30. doi:10.3322/caac.21590
- Clézardin P. Pathophysiology of bone metastases from solid malignancies. *Joint Bone Spine*. 2017;84(6):677-684. doi:10.1016/j.jbspin.2017.05.006
- Fornetti J, Welm AL, Stewart SA. Understanding the Bone in Cancer Metastasis. *Journal of Bone and Mineral Research*. 2018;33(12):2099-2113. doi:10.1002/jbmr.3618
- Hernandez RK, Wade SW, Reich A, Pirolli M, Liede A, Lyman GH. Incidence of bone metastases in patients with solid tumors: Analysis of oncology electronic

- medical records in the United States. *BMC Cancer*. 2018;18(1). doi:10.1186/s12885-017-3922-0
- 29 Paget S. The distribution of secondary growths in cancer of the breast. *The Lancet*. 1889;133(3421):571-573. doi:10.1016/S0140-6736(00)49915-0
- 30 Vlassov A V, Magdaleno S, Setterquist R, Conrad R. Exosomes: Current knowledge of their composition, biological functions, and diagnostic and therapeutic potentials. *Biochimica et Biophysica Acta – General Subjects*. 2012;1820(7):940-948. doi:10.1016/j.bbagen.2012.03.017
- 31 Balkwill F. Cancer and the chemokine network. *Nature Reviews Cancer*. 2004;4(7):540-550. doi:10.1038/nrc1388
- 32 Chaffer CL, Weinberg RA. A perspective on cancer cell metastasis. *Science*. 2011;331(6024):1559-1564. doi:10.1126/science.1203543
- 33 Folkman J. Angiogenesis in cancer, vascular, rheumatoid and other disease. *Nature medicine*. 1995;1(1):27-30. doi:10.1038/NM0195-27
- 34 Iyer A, Khaled G, Fang J, Madea H. Exploiting the enhanced permeability and retention effect for tumor targeting. *Drug discovery today*. 2006;11(17-18):812-818. doi:10.1016/j.drudis.2006.07.005
- 35 Scher HI, Morris MJ, Stadler WM, et al. Trial design and objectives for castration-resistant prostate cancer: Updated recommendations from the prostate cancer clinical trials working group 3. *Journal of Clinical Oncology*. 2016;34(12):1402-1418. doi:10.1200/JCO.2015.64.2702
- 36 Pesapane F, Downey K, Rotili A, Cassano E, Koh DM. Imaging diagnosis of metastatic breast cancer. *Insights into Imaging*. 2020;11(1). doi:10.1186/s13244-020-00885-4
- 37 WHO | Chronic rheumatic conditions. WHO. Published online 2016.
- 38 Neogi T. The epidemiology and impact of pain in osteoarthritis. *Osteoarthritis Cartilage*. 2013;21(9):1145-1153. doi:10.1016/j.joca.2013.03.018
- 39 Blagojevic M, Jinks C, Jeffery A, Jordan KP. Risk factors for onset of osteoarthritis of the knee in older adults: a systematic review and meta-analysis. *Osteoarthritis and Cartilage*. 2010;18(1):24-33. doi:10.1016/j.joca.2009.08.010
- 40 Lawrence RC, Felson DT, Helmick CG, et al. Estimates of the prevalence of arthritis and other rheumatic conditions in the United States. Part II. *Arthritis and Rheumatism*. 2008;58(1):26-35. doi:10.1002/art.23176
- 41 Sellam J, Berenbaum F. The role of synovitis in pathophysiology and clinical symptoms of osteoarthritis. *Nat Rev Rheumatol*. 2010;6(11):625-635. doi:10.1038/nrrheum.2010.159
- 42 Burr DB, Gallant MA. Bone remodelling in osteoarthritis. *Nature Reviews Rheumatology*. 2012;8(11):665-673. doi:10.1038/nrrheum.2012.130
- 43 Saberi Hosnijeh F, Bierma-Zeinstra SM, Bay-Jensen A-C. Osteoarthritis year in review 2018: biomarkers (biochemical markers). *Osteoarthritis and Cartilage*. 2019;27(3):412-423. doi:10.1016/j.joca.2018.12.002
- 44 Bondeson J, Blom AB, Wainwright S, Hughes C, Caterson B, van den Berg WB. The role of synovial macrophages and macrophage-produced mediators in driving inflammatory and destructive responses in osteoarthritis. *Arthritis Rheum*. 2010;62(3):647-657. doi:10.1002/art.27290
- 45 Wang Y, Teichtahl AJ, Cicuttini FM. Osteoarthritis year in review 2015: Imaging. *Osteoarthritis and Cartilage*. 2016;24(1):49-57. doi:10.1016/j.joca.2015.07.027
- 46 Bedson J, Croft PR. The discordance between clinical and radiographic knee osteoarthritis: a systematic search and summary of the literature. *BMC musculoskeletal disorders*. 2008;9:116. doi:10.1186/1471-2474-9-116
- 47 Hill CL, Hunter DJ, Niu J, et al. Synovitis detected on magnetic resonance imaging and its relation to pain and cartilage loss in knee osteoarthritis. *Annals of the rheumatic diseases*. 2007;66(12):1599-1603. doi:10.1136/ard.2006.067470
- 48 Yusuf E, Kortekaas MC, Watt I, Huizinga TWJ, Kloppenburg M. Do knee abnormalities visualised on MRI explain knee pain in knee osteoarthritis? a systematic Review. *Annals of the Rheumatic Diseases*. 2011;70(1):60-67. doi:10.1136/ard.2010.131904
- 49 Bruyère O, Honvo G, Veronese N, et al. An updated algorithm recommendation for the management of knee osteoarthritis from the European Society for Clinical and Economic Aspects of Osteoporosis, Osteoarthritis and Musculoskeletal Diseases (ESCEO). *Seminars in Arthritis and Rheumatism*. 2019;49(3):337-350. doi:10.1016/j.semarthrit.2019.04.008
- 50 Kolasinski SL, Neogi T, Hochberg MC, et al. 2019 American College of Rheumatology/Arthritis Foundation Guideline for the Management of Osteoarthritis of the Hand, Hip, and Knee. *Arthritis Care and Research*. 2020;72(2):220-233. doi:10.1002/art.41142
- 51 Kloppenburg M, Kroon FPB, Blanco FJ, et al. 2018 update of the EULAR recommendations for the management of hand osteoarthritis. *Annals of the Rheumatic Diseases*. 2019;78(1):16-24. doi:10.1136/annrheumdis-2018-213826
- 52 Fernandes L, Hagen KB, Bijlsma JWJ, et al. EULAR recommendations for the non-pharmacological core management of hip and knee osteoarthritis. *Annals of the Rheumatic Diseases*. 2013;72(7):1125-1135. doi:10.1136/annrheumdis-2012-202745
- 53 Palsis JA, Brehmer TS, Pellegrini VD, Drew JM, Sachs BL. The cost of joint replacement comparing two approaches to evaluating costs of total hip and knee arthroplasty. *Journal of Bone and Joint Surgery – American Volume*. 2018;100(4):326-333. doi:10.2106/JBJS.17.00161
- 54 Kamaruzaman H, Kinghorn P, Oppong R. Cost-effectiveness of surgical interventions for the management of osteoarthritis: a systematic review of the literature. *BMC Musculoskeletal Disorders*. 2017;18(1). doi:10.1186/s12891-017-1540-2
- 55 Wylde V, Hewlett S, Learmonth ID, Dieppe P. Persistent pain after joint replacement: prevalence, sensory qualities, and postoperative determinants. *Pain*. 2011;152(3):566-572. doi:10.1016/j.pain.2010.11.023
- 56 Beswick AD, Wylde V, Goberman-Hill R, Blom A, Dieppe P. What proportion of patients report long-term pain after total hip or knee replacement for osteoarthritis? A systematic review of prospective studies in unselected patients. *BMJ Open*. 2012;2(1):e000435. doi:10.1136/bmjopen-2011-000435
- 57 Kurtz SM, Lau E, Schmier J, Ong KL, Zhao K, Parvizi J. Infection burden for hip and knee arthroplasty in the United States. *J Arthroplasty*. 2008;23(7):984-991. doi:10.1016/j.arth.2007.10.017
- 58 Kloppenburg M, Ramonda R, Bobacz K, et al. Etanercept in patients with inflammatory hand osteoarthritis (EHOA): A multicentre, randomised, double-blind, placebo-controlled trial. *Annals of the Rheumatic Diseases*. 2018;77(12):1757-1764. doi:10.1136/annrheumdis-2018-213202
- 59 Kroon FP, Rubio R, Schoones JW, Kloppenburg M. Intra-Articular Therapies in the Treatment of Hand Osteoarthritis: A Systematic Literature Review. *Drugs Aging*. 2016;33(2):119-133. doi:10.1007/s40266-015-0330-5
- 60 Bingham CO, Buckland-Wright JC, Garner P, et al. Risenedron decreases biochemical markers of cartilage degradation but does not decrease symptoms or slow radiographic progression in patients with medial compartment osteoarthritis of the knee: Results of the two-year multinational knee osteoarthritis structural arthritis study. *Arthritis and Rheumatism*. 2006;54(11):3494-3507. doi:10.1002/art.22160
- 61 Losina E, Daigle ME, Suter LG, et al. Disease-modifying drugs for knee osteoarthritis: can they be cost-effective? *Osteoarthritis Cartilage*. 2013;21(5):655-667. doi:10.1016/j.joca.2013.01.016
- 62 da Costa BR, Düxesch E, Reichenbach S, Jüni P, Rutjes AW. Doxycycline for osteoarthritis of the knee or hip. *Cochrane Database of Systematic Reviews*. 2012;11:CD007323. doi:10.1002/14651858.CD007323.pub3
- 63 Wang K, Xu J, Hunter DJ, Ding C. Investigational drugs for the treatment of osteoarthritis. *Expert Opinion on Investigational Drugs*. 2015;24(12):1539-1556. doi:10.1517/13543784.2015.1091880
- 64 Vaysbrot EE, Osani MC, Musetti M-C, McAlindon TE, Bannuru RR. Are bisphosphonates efficacious in knee osteoarthritis? A meta-analysis of randomized controlled trials. *Osteoarthritis and Cartilage*. 2018;26(2):154-164. doi:10.1016/j.joca.2017.11.013
- 65 Hochberg MC, Guermazi A, Guehring H, et al. Effect of Intra-Articular Sprifermin vs Placebo on Femorotibial Joint Cartilage Thickness in Patients with Osteoarthritis: The forward Randomized Clinical Trial. *JAMA – Journal of the American Medical Association*. 2019;322(14):1360-1370. doi:10.1001/jama.2019.14735
- 66 Zhang W, Robertson J, Jones AC, Dieppe PA, Doherty M. The placebo effect and its determinants in osteoarthritis: Meta-analysis of randomised controlled trials. *Annals of the Rheumatic Diseases*. 2008;67(12):1716-1723. doi:10.1136/ard.2008.092015
- 67 Dieleman JL, Cao J, Chapin A, et al. US Health Care Spending by Payer and Health Condition, 1996-2016. *JAMA*. 2020;323(9):863. doi:10.1001/JAMA.2020.0734
- 68 Clynes MA, Harvey NC, Curtis EM, Fuggle NR, Dennison EM, Cooper C. The Epidemiology of Osteoporosis. *British medical bulletin*. 2020;133(1):105. doi:10.1093/bmb/ldaa005
- 69 Nelson R, Willson T, Nelson S, Newbold J, LaFleur J. The clinical epidemiology of male osteoporosis: a review of the recent literature. *Clinical Epidemiology*. 2015;7:65-76. doi:10.2147/CLEP.S40966
- 70 Watts NB, Adler RA, Bilezikian JP, et al. Osteoporosis in men: An Endocrine Society clinical practice guideline. *Journal of Clinical Endocrinology and Metabolism*. 2012;97(6):1802-1822. doi:10.1210/jc.2011-3045
- 71 Shahinian VB, Kuo Y-F, Freeman JL, Goodwin JS. Risk of Fracture after Androgen Deprivation for Prostate Cancer. *New England Journal of Medicine*. 2005;352(2):154-164. doi:10.1056/NEJMoA041943
- 72 Sung H, Ferlay J, Siegel RL, et al. Global Cancer Statistics 2020: GLOBOCAN Estimates of Incidence and Mortality Worldwide for 36 Cancers in 185 Countries. *CA Cancer J Clin*. 2021;71(3):209-249. doi:10.3322/caac.21660
- 73 Lowrance WT, Breaux RH, Chou R, et al. Advanced Prostate Cancer: AUA/ASTRO/SUO Guideline PART I. *Journal of Urology*. Published online September 22, 2020. doi:10.1097/ju.0000000000001375
- 74 Cornford P, van den Bergh RCN, Briers E, et al. EAU-EANM-ESTRO-ESUR-SIOG Guidelines on Prostate Cancer. Part II—2020 Update: Treatment of Relapsing and Metastatic Prostate Cancer. *European Urology*. Published online 2020. doi:10.1016/j.eururo.2020.09.046
- 75 Parker C, Castro E, Fizazi K, et al. Prostate cancer: ESMO Clinical Practice Guidelines for diagnosis, treatment and follow-up. *Annals of Oncology*. 2020;31(9):1119-1134. doi:10.1016/j.annonc.2020.06.011
- 76 Saylor P, Rumble R, Tagawa S, et al. Bone Health and Bone-Targeted Therapies for Prostate Cancer: ASCO

- Endorsement of a Cancer Care Ontario Guideline. *Journal of Clinical Oncology*. 2020;38(15):1736-1743. doi:10.1200/JCO.19.03148
- 77 Heidenreich A, Witjes W, Bjerklund-Johansen T, Patel A. Therapies used in prostate cancer patients by European urologists: data on indication with a focus on expectations, perceived barriers and guideline compliance related to the use of bisphosphonates. *Urologia internationalis*. 2012;89(1):30-38. doi:10.1159/000338810
- 78 Damji A, Bies K, Alibhai S, Jones J. Bone health management in men undergoing ADT: examining enablers and barriers to care. *Osteoporosis international: a journal established as result of cooperation between the European Foundation for Osteoporosis and the National Osteoporosis Foundation of the USA*. 2015;26(3):951-959. doi:10.1007/S00198-014-2997-6
- 79 Hu J, Aprikian A, Vanhuysse M, Dragomir A. Contemporary Population-Based Analysis of Bone Mineral Density Testing in Men Initiating Androgen Deprivation Therapy for Prostate Cancer. *Journal of the National Comprehensive Cancer Network*. 2020;18(10):1374-1381. doi:10.6004/JNCCN.2020.7576
- 80 Fu Y, Li C, Luo W, Chen Z, Liu Z, Ding Y. Fragility fracture discriminative ability of radius quantitative ultrasound: a systematic review and meta-analysis. *Osteoporosis International*. Published online July 30, 2020:1-16. doi:10.1007/s00198-020-05559-x
- 81 Park JS, Kim J, Elghiati A, Ham WS. Recent global trends in testicular cancer incidence and mortality. *Medicine (Baltimore)*. 2018;97(37):e12390. doi:10.1097/md.00000000000012390
- 82 Laguna M, Algaba F, Bokemeyer C, et al. EAU Guidelines on Testicular Cancer. ISBN 978-94-92671-07-3. Published online 2020. <https://uroweb.org/guideline/testicular-cancer/#1>
- 83 Watts NB, Adler RA, Bilezikian JP, et al. Osteoporosis in men: An Endocrine Society clinical practice guideline. *Journal of Clinical Endocrinology and Metabolism*. 2012;97(6):1802-1822. doi:10.1210/jc.2011-3045
- 84 Sprauten M, Brydøy M, Haugnes H, et al. Longitudinal serum testosterone, luteinizing hormone, and follicle-stimulating hormone levels in a population-based sample of long-term testicular cancer survivors. *Journal of Clinical Oncology*. 2014;32(6):571-578. doi:10.1200/JCO.2013.51.2715

SECTION I

BONE IN MALE UROLOGICAL MALIGNANCIES

CHAPTER 2

Risk of osteoporosis in testicular germ cell tumor survivors: a systematic review of the literature

J.P.M. Vrouwe^{1,2}, P.M.L. Hennis³, N.A.T. Hamdy⁴, S. Osanto¹, P.M. Willemse³

BJUJ Compass. 2022. doi: 10.1002/bco2.183

1 Leiden University Medical Centre, NL – *Department of Medical Oncology*

2 Centre for Human Drug Research, Leiden, NL

3 University Medical Centre Utrecht, Utrecht, NL – *Department of Urology*

4 Leiden University Medical Centre, NL – *Department of Medicine, Division of Endocrinology, and Center for Bone Quality*

ABSTRACT

CONTEXT Testicular germ cell tumour (TGCT) survivors are potentially at risk of developing osteoporosis, because of increased risk for disturbed bone remodeling associated with hypogonadism and anti-cancer treatment. A number of studies show bone loss and increased fracture risk in TGCT survivors, but data are scarce. There are no clinical guidelines or recommendations issued to address skeletal health in this group of patients potentially at high risk for osteoporosis.

OBJECTIVE To conduct a systematic review of available literature addressing bone health in TGCT patients. Subgroup analysis was performed to identify risk factors for bone loss and increased fracture risk.

EVIDENCE ACQUISITION Relevant databases including MEDLINE, Embase, and the Cochrane Library, including all English written comparative studies addressing bone health in TGCT patients were searched up to April 2020 and a narrative synthesis was undertaken. Risk of bias (RoB) was assessed using Cochrane ROBINS-I tool.

EVIDENCE SYNTHESIS 10 studies (8 cross-sectional and 2 longitudinal), recruiting a total of 1,997 unique TGCT patients, were identified and included in the analysis. Bone health was reported in various ways in different studies, and subgroups were defined heterogeneously, resulting in a widely varying prevalence of osteoporosis reported to be present in up to 73.2% of patients. Six studies reported low BMD associated with higher luteinizing hormone levels and one study showed a correlation between follow up duration and bone loss.

CONCLUSIONS TGCT survivors are at risk of developing osteoporosis and sustaining fragility fractures. Chemotherapy, pituitary-gonadal axis dysfunction and ageing are key risk factors, although available data are scarce. With increasing survival of TGCT patients, a clear unmet need has been identified to systematically evaluate and monitor skeletal health in larger numbers of survivors in order to develop best clinical practice guidelines to manage the insidious but potentially preventable and treatable skeletal complications of TGCT.

PATIENT SUMMARY Our systematic review summarizes available evidence on skeletal health status in TGCT survivors suggesting that chemotherapy and hypogonadism are key risk factors for bone loss.

Introduction

Testicular germ cell tumours (TGCT) are the most common malignancy in men aged 15 to 40 years,^{1,2} representing a global incidence of 552,266 new cases per year in 2012. The introduction of cisplatin-based chemotherapy in the management of TGCT patients in the seventies that resulted in a significant increase in cure rate to >95%,^{1,3} and thus to a significant increase in survival time allowing the development of late comorbidities of initial disease as well as its treatment such as persistent hypogonadism, cardiovascular disease, metabolic disease and secondary malignancies to be observed after decades of follow up.^{4,5} Depending on disease stage at diagnosis, treatment administered and time elapsed since treatment, between 16 to 27 percent of TGCT survivors have been reported to be hypogonadal.⁶⁻⁸ This increased risk for hypogonadism, a recognized significant risk factor for bone loss and increased fracture risk particularly in elderly patients, is possibly exacerbated by the higher prevalence of testicular dysgenesis syndrome observed in TGCT patients.⁹ The cytotoxic chemotherapy and concomitant administration of corticosteroids which are administered to TGCT patients, have also been associated with Leydig cell insufficiency-induced hypogonadism,¹⁰⁻¹² and with increased prevalence of low bone mineral density (BMD).¹³ Whether this is a direct effect of chemotherapy on bone remodeling, or an indirect effect on this process due to Leydig cell insufficiency and associated hypogonadism, is as yet to be established.¹⁴ Whereas a number of studies address bone health in TGCT survivors, outcomes vary widely between different studies.^{15,16} The current EAU germ cell tumour guideline does not address bone health evaluation and monitoring in TGCT survivors.¹⁷ The reported relatively high prevalence of hypogonadism and potential chemotherapy associated risk for bone loss and increased fracture risk in TGCT survivors has led us to systematically review all available evidence for increased prevalence of osteoporosis and fracture risk in this group of patients.

The main objective of this systematic review was to summarize available literature evidence for bone loss and increased fracture risk and potential risk factors thereof in TGCT survivors, in order to enable the issuing of best clinical recommendations for the evaluation and monitoring of this vulnerable group's bone health.

Evidence acquisition

SEARCH STRATEGY AND DATA SOURCES

The protocol for this review has been published (www.crd.york.ac.uk/PROSPERO; registration number CRD42019119868). Publications from 1990 to December 2021 were searched. The study selection process was done according to the Preferred Reporting items for Systematic reviews and meta-analyses (PRISMA).¹⁸

The full search strategy can be found as supplementary materials.

INCLUSION- AND EXCLUSION CRITERIA

All comparative studies were included. Single-arm case series, case reports, commentaries, reviews, and editorial commentaries were excluded. Relevant systematic reviews were scrutinized for potentially relevant studies for inclusion. Studies had to involve adult men with histologically proven TGCT stages T1-T3 according to the TNM staging system, who were treated with orchidectomy with or without chemotherapy and/or radiotherapy. Comparative arms could consist of healthy adult males, a non-cancer patient group, or different treatment- or outcome arms of TGCT patients. Studies that included patients with a metabolic bone disease or congenital hypogonadism were excluded.

Only studies that reported BMD as measured using dual x-ray absorptiometry (DXA) and/or fracture rates were included.

DATA EXTRACTION

Two authors (JPMV and PMLH) independently reviewed all titles, article abstracts and full-text articles for inclusion in the systematic review of the literature. At each step, outcomes were summarized, compared, and discussed. Disagreement was resolved by consensus after discussion or consultation with a third reviewer (PMW). The selection process is documented in a Preferred Reporting Items for Systematic Reviews and Meta-Analyses (PRISMA) flow diagram (Figure 1).¹⁸ A data extraction form was developed to enable uniform collection of detailed information from the studies that met the inclusion criteria and their outcomes. In case additional data were required to enable comparison with other included papers, authors of the selected articles were approached to request the missing data.

Extracted study characteristics included: country of conduct, study objective, study design, outcome measures, sample size (*N*), source of the study

population, eligibility criteria, treatment arms and methods including BMD definition of osteoporosis.

Data extracted also included demographic data (age, follow-up duration, BMI), details of treatment, BMD measurements (expressed as absolute values in g/cm², T-scores and Z-scores), plasma measurements of gonadal hormones and bone status indicators and any fracture data if available. In case of longitudinal studies, both baseline and follow-up data were extracted if available.

ASSESSMENT OF RISK OF BIAS

The risk of bias of each included study was independently assessed by two authors (JPMV, PMLH) using the Cochrane ROBINS-I tool.¹⁹ Any disagreement was resolved by consensus after discussion or consultation with a senior reviewer (PMW). A list of outcome-specific prognostic confounders was a priori defined by the authors for each domain. These confounders included age, tumour type, follow-up duration, definition of the intervention, missing data across groups and incomplete reporting of results.

DATA ANALYSIS AND STATISTICS

A narrative synthesis of the included studies was performed using descriptive statistics to summarize study and patient characteristics. Subgroups were defined on the basis of treatment administered, gonadal status, prevalence of fractures and follow-up duration. In case of longitudinal studies, baseline and follow-up data were included in the evaluation.

Outcome of laboratory investigations of gonadal hormones and/or bone status indicators, fracture rates and fracture risk scores (e.g. FRAX-score) were analyzed and reported in a descriptive manner.

Evidence synthesis

STUDY SELECTION

The PRISMA flow chart depicting the process of the systematic literature search and selection of the included studies is shown in Figure 1.¹⁸

After exclusion of duplicate studies, two authors (JPMV, PMH) selected 44 articles for full-text evaluation after independently completing a review of 176 Titles and Abstracts. A final cross-checked selection was made in keeping with the outlined inclusion criteria for the review. This selection resulted in the inclusion of ten full-text publications, providing data on a total of 2921

TGCT patients, the number of which decreased to 1997 TGCT patients after confirmation of uniqueness. A combined total of 180 non-TGCT subjects were included as controls in the 10 studies included in the systematic review.

CHARACTERISTICS OF THE STUDIES INCLUDED IN THE SYSTEMATIC REVIEW

Of the ten studies fulfilling the inclusion criteria for the systematic review, two studies, by Willemse (2014) and IJpma,^{20,21} were prospective non-randomized controlled studies, and eight were cross-sectional, non-randomized controlled studies.^{15,16,21-27} Population sizes ranged from 30 to 1249 patients. Study characteristics of the included studies are shown in Table 1.

Within studies, patients were grouped based on treatment received,^{15,22,24,26,27} Murugaesu, Willemse (2014) and Ondrusova (2009) grouped based on tumour stage,^{16,20,25} Willemse (2010) grouped based on or presence of vertebral fractures on routine spine X-rays.¹⁵ Three studies compared TGCT patients with a control group of men without a diagnosis of cancer. IJpma and Isaksson included healthy controls,^{21,24} and the third, by Foresta et al.²³ included patients with sexual dysfunction as control group. Nine studies additionally reported plasma gonadal hormone levels of LH, FSH, testosterone, SHBG and estradiol levels.^{15,16,20-26} Bone status indicators were reported in four studies, of which vitamin D, calcium and parathyroid hormone were reported in two or more studies.^{15,16,22}

RISK OF BIAS ASSESSMENT

The ROB assessment for all included studies is shown in Figure 2. This risk was 'serious' in all studies, although its potential cause remained confounding as treatments were used to define groups. There was also a potential bias in the selection of participants due to missing inclusion or exclusion criteria.

BMD MEASUREMENTS

The DXA systems used, the sites measured, and the definitions used to interpret measurement outcomes are shown in Table 1. Six studies used the Horizon Hologic system,^{15,16,20,21,25,26} for three studies, by Brown, Isaksson and Stutz,^{22,24,27} Lunar prodigy system was used, and Foresta did not report which DXA system was used.²³ All studies reported lumbar spine BMD outcomes, and nine studies also reported BMD as measured at other anatomic sites (hip/proximal femur, forearms, and/or whole body). The expression of outcome measures for BMD varied between studies; IJpma only

reported T-scores,²¹ Willemse (2010 and 2014) and Murugaesu reported T- and Z-scores,^{15,16,20} Brown and Foresta reported only absolute BMD values in g/cm²,^{22,23} Isaksson reported Z-scores and absolute BMD values in g/cm²,²⁴ and Stutz reported T- and Z-scores in addition to BMD in g/cm².²⁷ In the two studies by Ondrusova (2009, 2018),^{25,26} BMD outcomes were reported as odds ratios (OR) for osteopenia and osteoporosis compared to a reference group.

Nine studies used the world health organization (WHO) definitions for osteopenia (T-score >-1 to ≤-2.5) and osteoporosis (T-score ≤-2.5).^{15,16,20-22,24-27} Foresta did not provide the criteria used to define osteoporosis or osteopenia.²³ The prevalence of osteoporosis and/or osteopenia based on WHO definition definitions using T-scores or based on Z-scores was reported in eight papers.^{15,20,22-27}

TREATMENT GROUPS

Seven studies compared orchiectomy-only treated patients with patients who were treated with orchiectomy and with chemotherapy and/or radiotherapy.^{15,16,20,22,24-26} Isaksson also compared the outcomes in different TGCT treatment groups with those of healthy men.²⁴ Foresta bundled all treatment groups and compared those with the results of a non-TGCT group.²³ Two studies only included patients who had a specific treatment combination: IJpma et al.²¹ compared patients who had orchiectomy and chemotherapy with healthy subjects, and Stutz et al.²⁷ performed a within-patient comparison of patients irradiated- and non-irradiated sides.

BMD RESULTS

Table 2 details BMD results for all 10 studies included in the systematic review.

Three studies compared BMD results of TGCT patients with those of non-TGCT patients. IJpma and Isaksson had healthy controls as control group and Foresta had sexual dysfunction patients as a control group. IJpma and Foresta found a significantly lower BMD at the lumbar spine in TGCT patients compared to controls, with p-values of $p < 0.0001$, and $p = 0.010$.^{21,23,24} Both studies compared patients who had undergone various treatments in the form of orchiectomy with or without chemotherapy and/or radiotherapy with non-TGCT controls.^{21,23} Foresta also reported a significantly higher prevalence of Z-scores of ≤-2 in 23.8% in its combined mixed treatment TGCT group compared to 0% in the control group ($p < 0.0005$).²³

The third study, by Isaksson et al.²⁴, had a healthy control group and expressed BMD results as Z-scores. Although patients treated with chemotherapy had a trend for lower BMD, this was not statistically significant compared to any other TGCT treatment group or healthy controls. The overall reported prevalence of Z-score ≤ -1 was 19% at hip and 21% at lumbar spine in all TGCT patients, compared to 12% at the hip and 26% at the lumbar spine in healthy controls with no statistical significance reported.

Seven, including Isaksson, evaluated BMD outcomes in TGCT patients treated with orchiectomy alone compared to TGCT patients who had chemotherapy and/or radiotherapy in addition to orchiectomy. IJpma and Willemse (2014) were longitudinal and reported a lower BMD in their chemotherapy-treated group at follow-up.^{20,21} Ondrusova (2009) reported a higher prevalence of osteoporosis or osteopenia (73.2%) in the patients who had undergone bilateral orchidectomy compared to the unilateral group (49.1%, $p < 0.001$).²⁵ Other studies did not report statistically significant differences in BMD at the lumbar spine or hip/proximal femur regions between treatment groups.^{15,16,22,24,26}

A within-patient comparison of BMD at irradiated compared to non-irradiated hip sites was conducted by Isaksson and Stutz.^{24,27} Both found that the proximal femur BMD was not affected by radiotherapy ($p = 0.855$, $p = 0.37$). Stutz et al.²⁷ assessed BMD at the lumbar spine in irradiated patients and found that 13.3% had osteoporosis at lumbar vertebrae within the irradiated area, although on average lumbar spine BMD was higher than that of the device's reference population ($p = 0.018$).

FRACTURES

Fracture related outcomes (vertebral, hip or non-vertebral) were reported in only by Willemse (2010) and Stutz.^{15,27} Stutz reported 'no fractures' in the four patients diagnosed with osteoporosis.²⁷ In contrast, the study by Willemse (2010) reported a high prevalence of radiological vertebral fractures in 14% of patients based on evaluation of systematically performed lateral X-rays of the thoracic and lumbar spine in all patients included in their study ($n = 244$), although they found no association between number- or grade of severity of vertebral fractures and BMD, age, tumour stage, treatment with chemotherapy, gonadal status, or vitamin D levels.²⁰

FOLLOW-UP DATA

In the eight studies with a follow-up cross-sectional design, interval time between treatment administration and analysis of follow-up data varied

widely from 5 to 28 years after treatment.^{15,16,22-27} The longitudinal studies reported follow up data for 1 year (IJpma) and 5 years (Willemse, 2014) after start of treatment.^{20,21}

The effects of follow-up duration on changes in BMD were reported in five studies,^{16,20,21,23,25} with low BMD more frequently found in patients with a longer follow-up. Foresta reported a Z-score of ≤ -2 in 16.6% of patients after 2-3 years, and in 40.7% at 6-7 years, $p < 0.05$.²³ Ondrusova found a significant risk of developing osteopenia and/or osteoporosis 8 to 10 years after surgery in patients who had undergone unilateral or bilateral orchidectomy, respectively.²⁵ The studies with a longitudinal design by Willemse (2014) and IJpma, found a significantly lower BMD ($p \leq 0.004$, $p = 0.034$ respectively) at follow-up than at baseline in patients who had undergone chemotherapy, although the prevalence of osteoporosis and/or osteopenia was not reported for these treatment subgroups.^{20,21} Murugaesu did not find significant differences in BMD based on follow-up duration.¹⁶

LABORATORY MARKERS OF GONADAL STATUS AND BONE STATUS

Details of plasma levels of gonadal hormones and bone status indicators are shown in Table 3. Plasma levels of luteinizing hormone (LH) and free testosterone (FT) were reported in 9 studies,^{15,16,20-26} of which Foresta excluded hypogonadal patients, based on baseline testosterone levels. None of the studies reported testosterone/LH ratios and six of the 9 studies did not report on the use of testosterone replacement therapy, or addressed the possible relationship between gonadal status and BMD.^{16,21-23,25-27} Of the three studies that did, Isaksson did take into account testosterone and LH levels and use of hormone replacement therapy to define hypogonadism and found that hypogonadal patients with- and without androgen replacement therapy had 6-9% lower hip BMD ($p = 0.043$ and $p = 0.037$, respectively).²⁴ In the other two studies, by Willemse (2010, 2014), LH levels were not taken into account to define hypogonadism and there was no relationship identified between hypogonadism and BMD.^{15,20}

Subgroups of TGCT patients were found to have an increased LH level in six studies, of which five studies reported a significant difference specifically between treatment groups (chemotherapy yes/no, or patients/controls), including the three studies with non-cancer control groups.^{21,23-26} The sixth study, Willemse (2014) reported higher LH levels and lower BMD at follow-up in patients with more advanced (disseminated) TGCT compared to stage I TGCT. Significantly increased LH was found in combination with

a significantly lower BMD in five out of six studies,^{20,21,23,25,26} Isaksson, who reported increased LH levels, found a non-significant decrease in BMD.²⁴ Willemse (2010), Murugaesu and Brown found no significant changes in LH matching the absence of a difference in BMD outcomes.^{15,16,22}

Four studies reported significantly lower testosterone levels in TGCT. Willemse 2010, Ondrusova 2009 and Ondrusova 2018 showed significantly lower serum free testosterone levels 3 months to 30 years after treatment in patients who had undergone orchiectomy and chemotherapy, compared to those who had undergone orchiectomy alone.^{15,25,26} IJpma reported free testosterone levels were significantly lower in TGCT patients one year after treatment was started, compared to levels in healthy volunteers and also reported simultaneously lower BMD at follow-up compared to baseline.²¹ Murugaesu reported higher levels of free testosterone in the orchiectomy and chemotherapy group associated with a higher BMD compared to patients who had orchiectomy alone.¹⁶ The other four studies which reported on testosterone levels did not report significant or clinically relevant differences or trends, or a significant change in BMD over time between groups.^{20,22-24}

Estradiol levels were measured in five studies, testosterone levels were also measured in these studies.^{15,16,20,22,23} Willemse (2014) reported significantly higher pre-treatment estradiol level ($p=0.007$) in patients with disseminated disease, compared with levels in those with stage 1 disease.²⁰ No significant differences in estradiol levels were found between different stages of TGCT in four other studies.^{15,16,22,23}

Plasma concentrations of follicle stimulating hormone (FSH) were reported in five studies.^{15,16,20,22,23} Significantly higher FSH levels were found in TGCT patients compared to patients with sexual dysfunction by Foresta,²³ whereas Willemse (2010 and 2014) and Brown reported higher FSH levels in subgroups of patients with disseminated TGCT after chemotherapy, or after a long duration of follow-up.^{15,20,22} A combination of elevated FSH and low BMD was only observed in the by Brown, including a non-TGCT control group.²² Murugaesu did not report significant differences in FSH levels between treatment groups, or differences in BMD between groups.

Vitamin D and parathyroid hormone levels were measured in four studies,^{15,16,22,23} one of which (Foresta) found significantly lower levels of both vitamin D and parathyroid hormone in TGCT patients compared to non-cancer controls ($p<0.00001$). No statistically significant difference was found in plasma levels of calcium or sex hormone binding globulin (SHBG) in TGCT patients compared to controls or between TGCT treatment groups in any of the studies included.

Discussion

Testicular germ cell tumour survivors, particular those treated with chemotherapy, are at increased risk of having a low BMD. Evidence for this is mainly provided by data generated from two robust longitudinal studies showing a lower BMD in TGCT patients treated with chemotherapy compared to TGCT patients treated with orchiectomy only.^{20,21} A second risk factor for decreased BMD, identified in these patients is a long duration of follow-up, also after correction for age,^{20,21,23,25} possibly due to long-term effects of chemotherapy, the cumulative dose of corticosteroids administered as antiemetic treatment during chemotherapy, or longer exposure to hypogonadism.^{6,13} High serum LH concentrations, were found to be associated with low BMD measurements, also in the absence of low serum testosterone levels,^{20,23,24} suggesting that LH may have a direct negative effect on bone remodeling representing a risk factor for osteoporosis in its own right. This, however, remains to be established, as most studies did not include a separate analysis of the effect of gonadal status on BMD outcomes, which may identify the groups most at risk. The finding of high LH rather than low testosterone in TGCT survivors is in line with findings of three other studies, which did not show a relationship between serum estradiol and bone health or fracture risk.^{6,7,28} Use of corticosteroids was not reported in half of the studies and none of the studies performed a separate analysis or reported the dose/duration of corticosteroid treatment.^{20,29}

The only study systematically addressing the skeletal complications of TGCT in long-term survivors revealed a high prevalence of radiologically diagnosed often asymptomatic vertebral fractures pointing to an increased fracture risk, even in the absence of a low BMD.¹⁵ Findings from this study thus suggest that it is not only a decrease in bone quantity but potentially also a decrease in bone quality that may be responsible for the increased fracture risk observed in TGCT patients. Whether this fracture risk could be decreased or prevented by bone modifying treatment remains to be established.

This review has strengths as well as limitations. Its main strength is that to our knowledge, this is the first review that provides a complete overview of the current, albeit scarce literature on bone health, fracture risk and potential risk factors associated with loss of bone mass and increased fracture risk in TGCT survivors. A further strength of this review is that it is a PRISMA-adhering systematic review using a robust summation of available evidence on bone health in TGCT survivors.

The review also has a number of limitations including the heterogeneity and risk of bias of the populations studied and of reported outcomes, the small number of patients included in each study (mostly <100 patients), and the inability to access individual data for most studies, thus precluding the conduct of a meta-analysis. Eight of the 10 studies included in the review had a non-randomized, retrospective design, and the remaining two were non-randomized prospective studies.^{20,21} Some studies also used different measurement devices, not cross-calibrated with each other, and used at different time windows with different reference values.³⁰⁻³² These limitations highlight the need for standardized protocols, the collection of full sets of data, and uniform methods of reporting in order to allow the issuing of best clinical guidelines and recommendations on how best to manage the skeletal complications of TGCT

IMPLICATIONS FOR CLINICAL PRACTICE.

Despite the scarce data available, findings from this systematic review of the literature reinforce the view that bone health, especially fracture risk should be thoroughly evaluated and monitored in newly diagnosed as well as long-term TGCT survivors, an unmet need not addressed by the current, recently updated (2021) EAU guideline for follow-up of germ cell tumour survivors.¹⁷ The 2014 Endocrine Society's guidelines for the diagnosis of osteoporosis in men recommends screening hypogonadal men for osteoporosis from the age of 50.³³ However, TGCT survivors are generally young and survival rates have significantly improved, so that they might be exposed to the long-term effects of chronic hypogonadism, further increasing their future risk for osteoporosis, fragility fractures and associated morbidities.^{1,2,31,34} However data are still scarce in this field and further research is warranted to reach firmer conclusions on the relationship between treatment modalities, hypogonadism, BMD outcomes and fracture risk in TGCT survivors. Notwithstanding, in keeping with findings reported in studies included in this systematic review showing a high prevalence of abnormal gonadal status in TGCT patients that may significantly impact on bone health, we would urge for special attention to be paid to the evaluation and monitoring of gonadal hormone status and bone health including BMD measurements and clinical and radiological evaluation of fracture risk in newly diagnosed as well as long-term survivors of this malignancy regardless of their age.^{33,34}

IMPLICATIONS FOR FUTURE RESEARCH

In addition to the systematic collection of data, using standardized protocols for consolidation of the scarce available evidence, several additional issues remain to be explored on the pathophysiology of decrease bone quantity and/bone quality in TGCT survivors, both being potentially associated with increased bone fragility. There is an unmet need to address fracture rates in all future studies on TGCT survivors as solid fracture outcome data are lacking in the majority of thus far reported studies. Potential areas of interest include the role of abnormalities in gonadal hormones and in Leydig cell function, the latter reported to be prevalent in 9-27% of TGCT patients.^{6,7,35} On this topic, it would be of potential value to explore the value of human chorionic gonadotropin (hCG) levels as a biomarker of pituitary-Leydig cell axis function, in identifying patients at risk of developing hypogonadism-related complications.³⁶

CONCLUSIONS

Despite high risk of bias in all included studies, our findings from this systematic review suggest that TGCT survivors are at risk for skeletal complications in the form of decreased bone mass and increased bone fragility, also independently from BMD. Risk factors identified are chemotherapy-associated abnormalities in gonadal status and longer survival. These findings call for gonadal hormone status and bone health including BMD measurements and clinical and radiological evaluation of fracture risk to be investigated and monitored in newly diagnosed as well as long-term survivors of this malignancy regardless of age, in order to enable early diagnosis and management to reverse or prevent these complications.

REFERENCES

- Park JS, Kim J, Elghiaty A, Ham WS. Recent global trends in testicular cancer incidence and mortality. *Medicine*. 2018;97(37):12390. doi:10.1097/md.00000000000012390
- Williamson SR, Delahunt B, Magi-Galluzzi C, et al. The World Health Organization 2016 classification of testicular germ cell tumours: a review and update from the International Society of Urological Pathology Testis Consultation Panel. *Histopathology*. 2017;70(3):335-346. doi:10.1111/his.13102
- Bosetti C, Bertuccio P, Chatenoud L, Negri E, La Vecchia C, Levi F. Trends in mortality from urologic cancers in Europe, 1970-2008. *Eur Urol*. 2011;60(1):1-15. doi:10.1016/j.eururo.2011.03.047
- Haugnes HS, Aass N, Fossa SD, et al. Predicted cardiovascular mortality and reported cardiovascular morbidity in testicular cancer survivors. *J Cancer Surviv*. 2008;2(3):128-137. doi:10.1007/s11764-008-0054-1
- Willemse PM, Burggraaf J, Hamdy NA, et al. Prevalence of the metabolic syndrome and cardiovascular disease risk in chemotherapy-treated testicular germ cell tumour survivors. *Br J Cancer*. 2013;109(1):60-67. doi:10.1038/bjc.2013.226
- Nord C, Bjoro T, Ellingsen D, et al. Gonadal hormones in long-term survivors 10 years after treatment for unilateral testicular cancer. *Eur Urol*. 2003;44(3):322-328. doi:10.1016/s0302-2838(03)00263-x
- Sprauten M, Brydøy M, Haugnes H, et al. Longitudinal serum testosterone, luteinizing hormone, and follicle-stimulating hormone levels in a population-based sample of long-term testicular cancer survivors. *Journal of Clinical Oncology*. 2014;32(6):571-578. doi:10.1200/JCO.2013.51.2715
- Huddart RA, Norman A, Moynihan C, et al. Fertility, gonadal and sexual function in survivors of testicular cancer. *British Journal of Cancer*. 2005;93(2):200-207. doi:10.1038/sj.bjc.6602677
- Rodprasert W, Virtanen HE, Mäkelä JA, Toppari J. Hypogonadism and Cryptorchidism. *Front Endocrinol (Lausanne)*. 2019;10:906. doi:10.3389/fendo.2019.00906
- Isaksson S, Bogefors K, Ståhl O, et al. High risk of hypogonadism in young male cancer survivors. *Clinical Endocrinology*. 2018;88(3):432-441. doi:10.1111/cen.13534
- Howell S, Radford J, Ryder W, Shalet S. Testicular function after cytotoxic chemotherapy: Evidence of Leydig cell insufficiency. 1999;17(5):1493-1498.
- Bandak M, Jørgensen N, Juul A, et al. Testosterone deficiency in testicular cancer survivors – a systematic review and meta-analysis. *Andrology*. 2016;4(3):382-388. doi:10.1111/andr.12177
- Adler RA. Cancer treatment-induced bone loss. *Curr Opin Endocrinol Diabetes Obes*. 2007;14(6):442-445. doi:10.1097/MED.0b013e3282f169b5
- Howell SJ, Radford JA, Adams JE, Shalet SM. The impact of mild Leydig cell dysfunction following cytotoxic chemotherapy on bone mineral density (BMD) and body composition. *Clinical Endocrinology*. 2000;52(5):609-616. doi:10.1046/j.1365-2265.2000.00997.x
- Willemse PM, Hamdy NA, van Wulfpen L, van Steijn-van Tol AQ, Putter H, Osanto S. Prevalence of vertebral fractures independent of BMD and anticancer treatment in patients with testicular germ cell tumors. *Journal of Clinical Endocrinology and Metabolism*. 2010;95(11):4933-4942. doi:10.1210/jc.2010-0093
- Murugaesu N, Powles T, Bestwick J, Oliver RT, Shamash J. Long-term follow-up of testicular cancer patients shows no predisposition to osteoporosis. *Osteoporosis International*. 2009;20(9):1627-1630. doi:10.1007/s00198-008-0793-x
- Laguna M, Algaba F, Bokemeyer C, et al. EAU Guidelines on Testicular Cancer. *ISBN 978-94-92671-07-3*. Published online 2020. <https://uroweb.org/guideline/testicular-cancer/#1>
- Liberati A, Altman DG, Tetzlaff J, et al. The PRISMA Statement for Reporting Systematic Reviews and Meta-Analyses of Studies That Evaluate Health Care Interventions: Explanation and Elaboration. *PLoS Medicine*. 2009;6(7):e1000100. doi:10.1371/journal.pmed.1000100
- Sterne JA, Hernán MA, Reeves BC, et al. ROBINS-I: A tool for assessing risk of bias in non-randomised studies of interventions. *BMJ (Online)*. 2016;355:1-7. doi:10.1136/bmj.i4919
- Willemse PM, Hamdy NA, de Kam ML, Burggraaf J, Osanto S. Changes in bone mineral density in newly diagnosed testicular cancer patients after anticancer treatment. *Journal of Clinical Endocrinology and Metabolism*. 2014;99(11):4101-4108. doi:10.1210/jc.2014-1722
- Ijpma I, Renken RJ, Gietema JA, et al. Changes in taste and smell function, dietary intake, food preference, and body composition in testicular cancer patients treated with cisplatin-based chemotherapy. *Clinical Nutrition*. 2017;36(6):1642-1648. doi:10.1016/j.clnu.2016.10.013
- Brown JE, Ellis SP, Silcocks P, et al. Effect of chemotherapy on skeletal health in male survivors from testicular cancer and lymphoma. *Clinical Cancer Research*. 2006;12(21):6480-6486. doi:10.1158/1078-0432.ccr-06-1382
- Foresta C, Selice R, de Toni L, et al. Altered bone status in unilateral testicular cancer survivors: Role of CYP2R1 and its luteinizing hormone-dependency. *Journal of Endocrinological Investigation*. 2013;36(6):379-384. doi:10.3275/8650
- Isaksson S, Bogefors K, Akesson K, et al. Risk of low bone mineral density in testicular germ cell cancer survivors: association with hypogonadism and treatment modality. *Andrology*. 2017;5(5):898-904. doi:10.1111/andr.12383
- Ondrusova M, Ondrus D, Dusek L, Spanikova B. Damage of hormonal function and bone metabolism in long-term survivors of testicular cancer. *Neoplasma*. 2009;56(6):473-479. doi:10.4149/neo_2009_06_473
- Ondrusova M, Spanikova B, Sevcikova K, Ondrus D. Testosterone Deficiency and Bone Metabolism Damage in Testicular Cancer Survivors. *American Journal of Men's Health*. 2018;12(3):628-633. doi:10.1177/1557988316661986
- Stutz JA, Barry BP, Maslanka W, Sokal M, Green DJ, Pearson D. Bone density: is it affected by orchidectomy and radiotherapy given for stage I seminoma of the testis? *Clinical Oncology*. 1998;10(1):44-49. doi:10.1016/s0936-6555(98)80113-1
- la Vignera S, Cannarella R, Duca Y, et al. Hypogonadism and sexual dysfunction in testicular tumor survivors: A systematic review. *Frontiers in Endocrinology*. 2019;10(MAY). doi:10.3389/fendo.2019.00264
- Kanis JA. Osteoporosis III: Diagnosis of osteoporosis and assessment of fracture risk. *Lancet*. 2002;359(9321):1929-1936. doi:10.1016/S0140-6736(02)08761-5
- Genant HK, Grampp S, Glüer CC, et al. Universal standardization for dual X-ray absorptiometry: Patient and phantom cross-calibration results. *Journal of Bone and Mineral Research*. 1994;9(10):1503-1514. doi:10.1002/JBMR.5650091002
- Binkley N, Adler R, Bilezikian JP. Osteoporosis diagnosis in men: The T-score controversy revisited. *Current Osteoporosis Reports*. 2014;12(4):403-409. doi:10.1007/s11914-014-0242-z
- Watts NB, Leslie WD, Foldes AJ, Miller PD. 2013 International Society for Clinical Densitometry Position Development Conference: Task Force on Normative Databases. *Journal of Clinical Densitometry*. 2013;16(4):472-481. doi:10.1016/j.jocd.2013.08.001
- Watts NB, Adler RA, Bilezikian JP, et al. Osteoporosis in Men: An Endocrine Society Clinical Practice Guideline. *Journal of Clinical Endocrinology and Metabolism*. 2012;97(6):1802-1822. doi:10.1210/jc.2011-3045
- Bliuc D, Center JR. Determinants of mortality risk following osteoporotic fractures. *Current Opinion in Rheumatology*. 2016;28(4):413-419. doi:10.1097/BOR.0000000000000300
- Skakkebaek NE, Rajpert-De Meyts E, Main KM. Testicular dysgenesis syndrome: an increasingly common developmental disorder with environmental aspects. *Hum Reprod*. 2001;16(5):972-978. doi:10.1093/humrep/16.5.972
- Bandak M, Aksglaede L, Juul A, Rørth M, Daugaard G. The pituitary-Leydig cell axis before and after orchidectomy in patients with stage I testicular cancer. *European Journal of Cancer*. 2011;47(17):2585-2591. doi:10.1016/j.ejca.2011.05.026

Table 1 Summary of study- and patient characteristics.

Study ID	Country design recruitment period	Study arms	Treatment arms	N	Age mean (SD) [range]	Follow-up in years mean (SD) [range]	BMI mean (SD) [range]	Primary objective of the study
Ondrusova (2018) ²⁶	Slovakia, Cross-sectional, 2005-2015	Long-term TGCT survivors	Full group	1249	39	7 (7.2)		Evaluate effects of different therapeutic approaches for TGCT and changes in sex hormone levels and their impact on BMD.
			OE	313	38	6 (7.5)		
			OE+CT	665	41	5 (6.4)		
			OE+RT	271	38	7 (7.4)		
Ijpma (2017) ²¹	The Netherlands, Cross-sectional, 2012-2015	TGCT	baseline CT (B.EP)	21	32 [27-36]	1	24.3 (22.2-26.4)	Investigate systematic pattern of changes in taste and smell function, food preference, dietary intake and body composition in TGCT patients treated with cisplatin-based CT.
		TGCT	1 month after CT (B.EP)	11				
		TGCT	1y after CT (B.EP)	7				
		Healthy controls	N/A	48	32 [29-36]	N/A	23.5 (21.7-25.8)	
Isaksson (2017) ²⁴	Sweden, Cross-sectional, 2001-2006	TGCT	Full group	89	40.3 (7.4)	9.3 (2.69)	26.7 (3.84)	To assess low BMD, the risk of low BMD, and the possible associations with biochemical signs of hypogonadism and cancer treatment given.
		TGCT	OE	11	37.0 (7.4)	6.76 (2.47)	26.6 (4.2)	
		TGCT	OE + 1-2 cycles CT	28	28.9 (7.6)	8.60 (2.83)	26.7 (3.4)	
		TGCT	OE + 3-4 cycles CT	23	38.8 (7.1)	10.1 (2.21)	24.9 (2.8)	
		TGCT	OE + >4 cycles CT	5	40.9 (8.9)	9.68 (2.23)	27.5 (1.3)	
		TGCT	OE+RT	22	45.1 (5.7)	10.3 (2.43)	28.6 (4.8)	
		Healthy controls	N/A	91	41.2 (7.3)	N/A	25.6 (3.3)	

Study ID	Country design recruitment period	Study arms	Treatment arms	N	Age mean (SD) [range]	Follow-up in years mean (SD) [range]	BMI mean (SD) [range]	Primary objective of the study
Willemse (2014) ²⁰	The Netherlands, Prospective follow-up, 2007-2009	TGCT patients (seminoma and non-seminoma)	Full group	63	33 [16-70]	-		To evaluate longitudinal changes in BMD in newly diagnosed and recently orchiectomized TGCT patients up to 5 years after anticancer treatment.
			Stage I	27	35 [22-70]	0		
			Stage I 5y F-U	27		5		
			Disseminated (CT)	36	34 [16-59]	0		
			Disseminated (CT) 5y F-U	36		5		
Foresta (2013) ²³	Italy, Cross-sectional, 2010-2011	Testicular germ cell tumors	OE, RT and/or CT	125	34.0 (6.1)	4.6 (2.0)	23.6	To determine bone metabolism markers and BMD in a cohort of normo-testosteronemic patients who underwent unilateral OE for TGCT.
		Sexual dysfunction controls	N/A	41	35.8 (6.2)	N/A	22.9	
Willemse (2010) ¹⁵	The Netherlands, Cross-sectional	Orchiectomized patients with/without CT.	Full group	244	39.4 [18.2-66.9]			To assess skeletal fragility in a cohort of TGCT patients who have been followed-up for up to 28 years after initial diagnosis and treatment.
		1-28 y after cure (OE and when required CT)	Long term follow-up group	199	40.0 [18.2-66.9]	[1-28]		
			Long term OE+RT	152				
	After unilateral orchiectomy, before commencing CT	Long term OE	47					
		Newly diagnosed	45 ^a	32.0 [18.3-54.3]	0 - 3 months after OE			

Study ID	Country design recruit-ment period	Study arms	Treatment arms	N	Age mean (SD) [range]	Follow-up in years mean (SD) [range]	BMI mean (SD) [range]	Primary objective of the study
Murugaesu (2009) ¹⁶	United Kingdom, Cross-sectional, NR	TGCT	Full group	39	48.0 [30-74]	15.7 [5.3-28.3]	24.8 (15.7 - 35.1)	To establish the long-term incidence of osteoporosis following OE with- or without CT.
		TGCT	OE	14	50.4 [30-74]	13.1 [5.7-23.0]	24.6 (15.7-35.1)	
		TGCT	OE+RT	25	43.6 [34-64]	17.1 [5.3-28.3]	26.1 (20.6-31.1)	
Ondrusova (2009) ²³	Slovakia, Cross-sectional, 2005-2009	TGCT	Full group	879	32.6 [14-68]	8 [0.25-38.5]		To investigate hormonal profile and osteological examination in patients with uni- and bilateral TGCT and come to an algorithm of follow-up for these patients.
		Unilateral TGCT	OE+CT	823	32 (9.0) [14-68]	7.4 [0.25-29.41]		
			OE+RT					
			OE+CT+RT					
			RT in total					
	CT in total							
	Bilateral TGCT			56	41.3 [1.1-38.5]	14.6 [1.1-38.5]		
			OE+CT					
			OE+RT					
			OE+CT+RT					

Study ID	Country design recruit-ment period	Study arms	Treatment arms	N	Age mean (SD) [range]	Follow-up in years mean (SD) [range]	BMI mean (SD) [range]	Primary objective of the study
Brown (2006) ²²	United Kingdom, Cross-sectional, 2001-2003	TGCT	OE	101	42.3 [23.6-69.6]	N/A	NR	To assess the extent of bone loss due to previous CT in men, and to determine if the rate of bone turnover in such patients is abnormal by measurement of bone metabolism markers.
		TGCT	OE+RT	64	40.4 [19.4-67.8]	4.1 [1.0-29.2]	NR	
Stutz (1998) ²⁷	United Kingdom, Cross-sectional, 1994-1995	Intra-patient comparison of TGCT patients	Full group	30	42.93 (9.82) [25-63]	2.3 [0.17-10.5]		To determine whether treatment of TGCT with RT results in significant long-term effects on BMD.
			irradiated side	30	42.93 (9.82) [25-63]	2.3 [0.17-10.5]		
			non-irradiated side	30	42.93 (9.82) [25-63]	2.3 [0.17-10.5]		

^a Short term follow-up group excluded from BMD analysis, as these were the same patients as those analyzed in the Willemse (2014) study

^b Data from Ondrusova (2009) is not interpreted separately, as it appears there is a large overlap with the population of Ondrusova (2018)

^c Different DXA systems use different ethnicity reference populations to calculate T- and Z-scores. For this- and various other reasons, outcomes are not directly comparable

TGCT Testicular germ cell tumor, NR not reported, SD Standard deviation, BMI body mass index, BMD bone mass density, OE orchiectomy, CT chemotherapy, RT radiotherapy, LH luteinizing hormone,

FSH follicle stimulating hormone, T Testosterone, Oes Estradiol, Vit. D Vitamin D, Ca calcium, PTH parathyroid hormone, SHBG sex hormone binding globuline, CTx C-telopeptide, A.F alkaline phosphatase, DXA dual energy X-ray absorptiometry, WHO world health organization, L5 lumbar spine, prox. proximal

Table 2 Summary of bone mineral density outcomes.

Study characteristics		Lumbar spine BMD outcomes			Proximal femur/Total hip BMD outcomes			Other BMD outcomes																
StudyID	Treatment arms	BMD g/cm ² mean (SD)	T-Score (SD) <IQR> [range]	Z-score (SD) <IQR> [range]	BMD g/cm ² (SD) <IQR> [range]	T-Score (SD) <IQR> [range]	Z-score (SD) <IQR> [range]	BMD g/cm ² (SD) <IQR> [range]	T-Score (SD) <IQR> [range]	Z-score (SD) <IQR> [range]														
Ondrusova (2018) ²⁶	TGCT full group																							
	TGCT OE		-0.2																					
	TGCT OE+CT		<-0.8-1.6>																					
	TGCT OE+RT		-0.5																					
			<-1.3-0.4>																					
			-0.5																					
			<-0.9--0.4>																					
	Healthy controls		-0.4																					
			<-1.2-0.6>																					
Lower BMD in patients at follow-up compared to baseline (1mp=0.010 and 1yp=0.034)																								
Isaksson (2017) ²⁴	TGCT Full group	1.248 (0.162)		1.248 (0.162)	1.073 (0.129)		-0.119 (0.934)																	
	TGCT OE	1.275 (0.137)		0.242 (0.913)	1.127 (0.119)		0.294 (0.768)																	
LowBMD (Z-score <-1) in 19% (hip) and 21% (Ls) of the patients and in 12% (hip) and 26% (Ls) of the control group (Ns difference).																								
Study characteristics	Lumbar spine BMD outcomes																							
	StudyID	Treatment arms	BMD g/cm ² mean (SD)	T-Score (SD) <IQR> [range]	Z-score (SD) <IQR> [range]	BMD g/cm ² (SD) <IQR> [range]	T-Score (SD) <IQR> [range]	Z-score (SD) <IQR> [range]	Proximal femur/Total hip BMD outcomes															
									BMD g/cm ² (SD) <IQR> [range]	T-Score (SD) <IQR> [range]	Z-score (SD) <IQR> [range]	Other BMD outcomes												
	Healthy controls	Irradiation	1.206 (0.159)	-0.230 (1.23)	1.082 (0.125)	0.038 (0.867)	1.268 g/cm ² (SD 0.154); Untreated hypogonadal patients: mean: 1.207 g/cm ² (SD 0.198), p=0.022. Treated hypogonadal patients: mean 1.206 g/cm ² (SD 0.125), p=0.012.	Absolute BMD and Z-scores of the hip did not differ between irradiated and the non-irradiated sides (both p=0.37)																
									NS difference between treatment groups (p-value range: 0.23-0.67). NS difference between full group of TGCT patients and Healthy controls (p=0.27)	NS difference between treatment groups (p-value range: 0.07-0.51), lowest p-values in CT groups. NS difference between full group of TC patients and Healthy controls (p=0.14)	NS difference between treatment groups (p=0.043. hypogonadism had lower LS BMD compared to eugonadal patients. Eugonadal patients: mean: 1.081 g/cm ² , SD 0.121, untreated hypogonadal patients: mean: 1.066 g/cm ² (SD 0.167), p=0.037, treated hypogonadal patients: mean 1.044 g/cm ² (SD 0.084), p=0.043.	Patients with untreated hypogonadism had lower LS BMD. Eugonadal patients: mean 1.081 g/cm ² , SD 0.121, untreated hypogonadal patients: mean: 1.066 g/cm ² (SD 0.167), p=0.037, treated hypogonadal patients: mean 1.044 g/cm ² (SD 0.084), p=0.043.												
	TGCT OE + 1-2 cyclesCT	TGCT OE + 3-4 cyclesCT	TGCT OE + >4 cyclesCT	TGCT OE + Irradiation	Healthy controls	1.241 (0.173)	1.233 (0.121)	1.139 (0.060)					1.276 (0.208)	1.206 (0.159)	-0.141 (1.40)	0.004 (0.930)	-1.226 (0.442)	0.141 (1.64)	-0.230 (1.23)	1.082 (0.125)	0.038 (0.867)	1.084 (0.145)	1.022 (0.079)	1.012 (0.071)

Study characteristics		Lumbar spine BMD outcomes		Proximal femur/Total hip BMD outcomes		Other BMD outcomes	
StudyID	Treatment arms	BMD g/cm ² mean (SD)	T-Score (SD) <IQR> [range]	Z-score (SD) <IQR> [range]	BMD g/cm ² (SD) <IQR> [range]	T-Score (SD) <IQR> [range]	Z-score (SD) <IQR> [range]
Willemse (2014) ²⁰	TGCT full group						
	TGCT Stage I (OE)		-0.21, 95%CI -2.42-2.97	-0.14, 95%CI -2.42-2.97		0.02, 95%CI -1.42-1.53	0.23, 95%CI -1.42-1.57
	TGCT Stage I (OE) 5y F-U			-0.74, 95%CI -2.57-3.55			-0.35, 95%CI -1.60-1.09
	TGCT Disseminated (OE+CT)		-0.43, 95%CI -2.87-1.78	-0.37, 95%CI -2.54-1.78		0.02, 95%CI -1.49-1.77	0.22, 95%CI -1.12-1.90
TGCT Disseminated (OE+CT) 5y F-U			-0.61, 95%CI -2.38-1.64				-0.22, 95%CI -1.23-1.09
		NS difference between groups at baseline. Decreased: at 5 years in patients with metastatic disease and CT (p<0.004)		NS difference between groups at baseline. Decreased BMD at 5 years in patients with metastatic disease and CT (p<0.0001)		Prevalences at baseline Osteoporosis: 3.2% at LS, 0% at the hip Osteopenia: 9.5% at LS and hip, 14.3% at LS and 1.6% at the hip. NS difference between metastatic- or Stage 1 TGCT patients. Prevalences at 1y after anticancer treatment: Osteoporosis: 1.6% at LS, 0% at the hip. Osteopenia: 12.7% at LS and hip, 20.6% at LS, 1.6% at the hip. NS difference between metastatic- or Stage 1 TGCT patients. BMD changes were independent of gonadal state, vit. D and β-Ctx	

Study characteristics		Lumbar spine BMD outcomes		Proximal femur/Total hip BMD outcomes		Other BMD outcomes	
StudyID	Treatment arms	BMD g/cm ² mean (SD)	T-Score (SD) <IQR> [range]	Z-score (SD) <IQR> [range]	BMD g/cm ² (SD) <IQR> [range]	T-Score (SD) <IQR> [range]	Z-score (SD) <IQR> [range]
Foresta (2013) ²³	TGCT OE, RT and / or CT	1.003 (0.146)			0.981 (0.115)		
	Sexual dysfunction	1.179 (0.119)			1.151 (0.128)		
		Lower BMD in TGCT patients (p<0.00001)		Lower BMD in TGCT patients (p<0.00001)		Lower BMD in TGCT patients (p<0.00001)	
Willemse (2010) ¹⁵	TGCT full group						
	TGCT 1-28y follow-up		-0.33 (1.19)	-0.14 (1.16)		-0.53 (0.93)	-0.05 (0.89)
	TGCT, VF						
	TGCT, no VF		-0.33 (1.32)	-0.17 (1.35)		-0.32 (SD 0.96)	0.13 (0.95)
additional data long term F-U	TGCT OE	1.05 (0.145)			0.888 (0.13)		
	TGCT OE+CT	1.04 (0.15)			0.858 (0.13)		
		NS difference between groups with- or without VF, and treatment groups.		NS difference between groups with- or without VF, and treatment groups.		NS difference in the prevalence of osteoporosis between treatment groups. Severity or number of VF was independent of age, tumor type, staging, previous CT, gonadal status, vitamin D levels or BMD values.	

Study characteristics		Lumbar spine BMD outcomes		Proximal femur/Total hip BMD outcomes		Other BMD outcomes	
StudyID	Treatment arms	BMD g/cm ² mean (SD)	T-Score (SD) <IQR> [range]	Z-score (SD) <IQR> [range]	BMD g/cm ² (SD) <IQR> [range]	T-Score (SD) <IQR> [range]	Z-score (SD) <IQR> [range]
Murugaesu (2009) ¹⁶	TGCT OE with or without CT		0.1, 95%CI -0.3-0.5	0.4, 95%CI -0.1-0.8		-0.1, 95%CI -0.4-0.2	0.3, 95%CI -0.001 - 0.6
	Local disease, OE		0.2, 95%CI -0.3-0.7	0.5, 95%CI -0.1-1.1		-0.1, 95%CI -0.6-0.3	0.2, 95%CI -0.2 - 0.7
	N+/M+ disease, OE+CT		-0.1, 95%CI -0.8-0.6	0.1, 95%CI -0.7-0.8		-0.1, 95%CI -0.3-0.5	0.4, 95%CI -0.1-0.8
ns difference between patient groups, T-score: <i>p</i> =0.48, Z-score: <i>p</i> =0.37.		ns difference between patient groups, T-score: <i>p</i> =0.50, Z-score: <i>p</i> =0.54.					
Ondrusova (2009) ^{2,5}	TGCT full group						
	Unilateral TGCT						
	OE+CT						Osteoporosis and/or osteopenia in 404 patients (49.1%) OR compared to OE alone (95% CI):
	OE+RT						OR osteopenia: 1.19 (0.85-1.66) OR osteoporosis: 1.12 (0.66-1.91)
	OE+CT+RT						OR osteopenia: 1.16 (1.01-1.80) OR osteoporosis: 1.27 (0.67-2.43)
RT in total						OR osteopenia: 2.38 (0.69-8.17) OR osteoporosis: 1.52 (0.30-7.69)	
CT in total						OR osteopenia: 1.23 (1.02-1.89) OR osteoporosis: 1.30 (0.69-2.44)	
							OR osteopenia: 1.21 (0.87-1.69) OR osteoporosis: 1.13 (0.67-1.92)

Study characteristics		Lumbar spine BMD outcomes		Proximal femur/Total hip BMD outcomes		Other BMD outcomes	
StudyID	Treatment arms	BMD g/cm ² mean (SD)	T-Score (SD) <IQR> [range]	Z-score (SD) <IQR> [range]	BMD g/cm ² (SD) <IQR> [range]	T-Score (SD) <IQR> [range]	Z-score (SD) <IQR> [range]
Bilateral TGCT	OE+CT						
	OE+RT						
	OE+CT+RT						
Osteoporosis/osteopenia in 41 patients (73.2%) odds ratio for Osteoporosis + osteopenia: 2.57 (95% CI: 1.42-5.02, <i>p</i> <0.001) OR for Osteoporosis compared to unilateral disease: 3.34 (95% CI: 1.44-7.31, <i>p</i> <0.001)		OR osteopenia: 1.81 (0.39-8.48) OR osteoporosis: 1.23 (0.27-5.65)		OR osteopenia: 0.76 (0.14-4.16) OR osteoporosis: 0.86 (0.13-5.63)		not evaluated due to sample size	
Higher OR for osteoporosis and osteopenia in the bilateral group than the unilateral group (<i>p</i> <0.001). Higher prevalence of osteopenia/osteoporosis in the unilateral RT treated group (<i>p</i> <0.05). Otherwise no statistically significant differences between treatment groups.		Prevalence of low BMD in OE group: 0%		Prevalence of low BMD in OE+CT group: 16.7%, osteoporosis: 0%		Prevalence of low BMD in OE+CT group: 17% osteoporosis: 1.7%	
Brown (2006) ²²	TGCT OE	1.336 (0.185)			1.142 (0.158)		
	TGCT OE+RT	1.335 (0.153)			1.152 (0.146)		
NS difference, (<i>p</i> =0.680)		NS difference, (<i>p</i> =0.662)					
BMD was not lower than that of the Lunar reference population.							

Study characteristics		Lumbar spine BMD outcomes			Proximal femur/Total hip BMD outcomes			Other BMD outcomes
Study ID	Treatment arms	BMD g/cm ² mean (SD)	T-Score (SD) <IQR> [range]	Z-score (SD) <IQR> [range]	BMD g/cm ² (SD) <IQR> [range]	T-Score (SD) <IQR> [range]	Z-score (SD) <IQR> [range]	
Stutz (1998) ²⁷	TGCT survivors, intra-patient comparison	1.290 (0.207)	0.412 (1.725)	0.761 (1.659)	1.09 (0.19)	0.16 (1.2)	0.43 (1.23)	Low BMD: osteoporosis of the LS in 13.3% of patients none had osteopenia of the LS. However, mean Z-scores of the whole body resulted in a Z-score significantly greater than 0 (p=0.004). No fractures occurred in the osteopenic patients (n=4)
	irradiated side				1.458 (0.21) [1.099-1.867]			
	non-irradiated side				1.454 (0.21) [1.025-1.941]			No association of LST-score with age was found.
		t-test against mean of O, BMD Z-score significantly higher than irradiated- and non-irradiated side reference population (p=0.018).						
		NS difference between the irradiated- and non-irradiated side (p=0.855)						

A Different DXA systems use different ethnicity reference populations to calculate T- and Z-scores. For this- and various other reasons, outcomes are not directly comparable
SD standard deviation, BMD bone mineral density, 95%CI 95%-confidence interval, IQR interquartile range, OR odds ratio, OE orchiectomy, CT chemotherapy, RT radiotherapy, TGCT testicular germ cell tumor, F-U follow-up, NS non-significant, VF vertebral fractures, LS lumbar spine, y years, N+ M+ disease patients with tumor-positive lymph nodes or metastatic disease.

Table 3 Summary of serum blood measurements.

Study characteristics		Sex hormones			Bone markers						
Study ID	Treatment arms	N	LH (IU/L) ^b mean/median (SD) <IQR> [RANGE]	Testosterone ^c (nmol/L) mean/median (SD) <IQR> [RANGE]	FSH (IU/IL) ^d mean/median (SD) <IQR> [RANGE]	Estradiol ^e (pmol/L) mean/median (SD) <IQR> [RANGE]	SHBG ^f mean/median (SD) <IQR> [RANGE]	Vit. D (nmol/L) mean/median (SD) <IQR> [RANGE]	Calcium mean/median (SD) <IQR> [RANGE]	PTH mean/median (SD) <IQR> [RANGE]	
Ondrusova (2018) ⁶	TGCT	1249									
	Full group										
	OE	313	Elevated in 23 patients	decreased in 46 patients							
	OE+CT	665	Elevated in 154 patients, OR 2.257 (1.32-3.86)	decreased in 103 patients, OR 1.646 (1.073-2.523)							
Ujma (2017) ²¹	OE+RT	271	Elevated in 43 patients (OR 3.79 (2.39-6.02)	decreased in 66 patients, OR 1.050 (0.716-1.539)							
	Healthy controls		Elevated in OE+CT and OE+RT groups	NS difference							
	baseline CT (B.EP)	14/15	3.9 <0.3-5.7>	19.0 <14.2-21.0>							
	1m after CT (B.EP)	12/17	8.8 <7.1-11.1>	21.5 <15.9-26.56>							
Isaksson (2017) ²⁴	1y after CT (B.EP)	6/7	5.5 <4.5-9.7>	16.3 <12.0-22.4>							
	Healthy controls	46	3.5 <2.8-4.9>	24 <19-28>							
	Full group		p-values NR	Lower in patients at baseline (p=0.007)							
	OE	11	3.8 <3.2-4.6>	13.0 (3.9)							
Isaksson (2017) ²⁴	OE+1-2 cycles CT	28	5.1 <4.1-6.4>	13.1 (3.7)							
	OE+3-4 cycles CT	23	6.2 <4.6-8.0>	12.9 (3.6)							
	OE+>4 cycles CT	5	n.d. due to group size	n.d. due to group size							
	OE+RT	22	4.6 <3.0-7.0>	12.4 (3.1)							
Healthy controls	N/A	91	3.3 <2.1-4.2>	13.9 (4.0)							
		Significantly Elevated in all but the OE only group.		NS difference							

Study ID	Study arms	Treatment arms	N	Sex hormones			Bone markers					
				LH (IU/L) ^b mean/median (SD) <IQR> [RANGE]	Testosterone ^c (nmol/L) mean/median (SD) <IQR> [RANGE]	FSH (IU/1L) ^d mean/median (SD) <IQR> [RANGE]	Estradiol ^e (pmol/L) mean/median (SD) <IQR> [RANGE]	SHBG ^f mean/ median (SD) <IQR> [RANGE]	Vit. D (nmol/L) mean/median (SD) <IQR> [RANGE]	Calcium mean/median (SD) <IQR> [RANGE]	PTH mean/ median (SD) <IQR> [RANGE]	
Willmense (2014) ²⁰	Study arms	full group	63									
	Stage I	Stage I	27	7.5 (4.9) [2.9-25.6]	17.4 (7.5) [0.2-33.9]	12.4 (7.7) [4.6-32.1]	69 (20) [28-98]	30.5 (18.3) [15.7-48.4]				
	Stage I 5FU	Stage I 5FU	27	6.6 (4.6) [3.1-20.1]	16.1 (7.2) [0.7-29.2]	11.7 (11.1) [4.5-48.5]	66 (20) [38-99]	33.1 (10.1) [12.5-49.9]				
	Disseminated	Disseminated	36	5.9 (5.8) [0.1-24.8]	17.4 (5.6) [4.7-30.2]	10.4 (11.1) [0.1-44.5]	104 (56) [31-2400]	31.2 (12.0) [6.8-64.0]				
	Disseminated 5FU	Disseminated 5FU	36	6.7 (3.2) [2.1-13.5]	16.2 (5.8) [7.0-29.5]	12.8 (8.0) [2.9-29.1]	82 (21) [35-118]	32.8 (13.9) [11.7-59.3]				
Foresta (2013) ^{23 a}	Sexual dysfunction	OE, RT and/or CT	105	6.9 (3.6)	17.6 (4.9)	12.5 (9.9)	95.4 (33.9)	NS	41.6 (20.6)	2.41 (0.11)	72.8 (28.6)	
		N/A	41	3.9 (2)	16.6 (5.7)	3.6 (1.6)	89 (32)		74.9 (3.9)	2.38 (0.1)	49.5 (14.2)	
Willmense (2010) ¹⁵	Sexual dysfunction	full group	279	6.0 [0.1-43.5]	NS	p < 0.00001	NS	NS	59 [48-149]	2.45 [2.00-2.83]	5.1 [0.6-19.0]	
	Long term follow-up group	Long term follow-up group	254	high LH: 36 (18.1%)	15 [7-34]	12 [0.1-100.1]	76 [4-373]	decreased in 91 (45.7%)				
	Long term follow-up with VF	Long term follow-up with VF	27	7.4 [2.8-19.7]	15 [7-26]	11 [5.3-39.0]	71 [48-134]		60 [27-116]	2.44 [2.00-2.66]	5.9 [2.1-10.8]	
	Long term follow-up without VF	Long term follow-up without VF	172	6.1 [1.9-37.5]	14 [7-32]	13.5 [2.4-80.0]	74 [10-187]		60 [20-149]	2.45 [2.24-2.83]	4.9 [0.6-19.0]	
	additional data long term F-U	TGCT OE	47	5.6 [2.3-23.1]	16.3 [8-28.8]	9.7 [3.6-34.7]	76 [10-187]					
Murugaesu (2009) ¹⁶	Unilateral disease	OE with or without CT	39	6.9 < 5.0-13.5 > [0.3-80.1]	14.0 < 10.9-19.1 > [4.2-56.4]	12 < 6.4-27 > [0.9-149.2]	88 < 71.5-115 > [50-138]	31 < 26.8-35.3 > [10-70]	59 < 50-69 > [16-141]			
		OE	14	7.1 < 5.1-14.1 > [0.3-80.1]	13.0 < 9.9-14.9 > [4.2-56.4]	15.9 < 7.0-28.2 > [0.9-149.2]	88 < 73-111 > [50-120]	31 < 25.3-36.8 > [10-70]	59 < 46-72 > [16-122]			
		OE+CT	25	6.8 < 4.7-11.7 > [3.4-34.6]	17.4 < 13.9-25.3 > [7.8-28]	9.85 < 6.0-21.2 > [4.2-42.4]	92.5 < 67-127 > [53-138]	31 < 24.0-38.0 > [15-46]	59 < 40-79 > [19-141]			
Ondrusova (2009) ²⁵	Unilateral disease	Full group	879	NS	Higher in OE+CT group (p=0.01)	NS	NS	NS	NS	NS	NS	
	Bilateral disease	OE+CT, OE+RT, OE+CT+RT, RT total, CT total	56	Elevated in 45 patients (83.9%)	NS increase in CT group (p=0.398)	Elevated in CT group (p=0.663)	NS difference, p=0.663	Elevated in CT group (p=0.198)	NS difference	NS difference	NS difference	
Brown (2006) ²²	Unilateral disease	OE+CT	101	6.98 (3.4)	12.0 (4.6)	13.6 (9.55)	25.5 (5.8)		36.2 (5.2)			
	Bilateral disease	OE+CT	64	8.26 (6.21)	13.1 (7.7)	18.4 (14.4)	27 (8.4)		37 (17.2)			
Stutz (1998) ²⁷	Sexual dysfunction	full group	30	NS	NS	NS	NS	NS	NS	NS	NS	

A Only normo-testosteronemic patients were evaluated in the study reported by Foresta et al. (2013) (testosterone normal-range not reported) / b LH reference ranges: Ondrusova 2018: <8.2mU/mL, Ijpm: not reported, Isaksson: 1.0-10.0U/L, Willemse 2014: 2.0-10.0U/L, Foresta: not reported, Willemse 2010: 2.0-10.0U/L, Murugaesu: 1.80-8.0U/L, Ondrusova 2009: Brown: 1.7-12.2IU/L. / c Testosterone reference ranges: Ondrusova 2018: >12.0nmol/L, Ijpm: not reported, Isaksson: <10nmol/L, Willemse 2014: 8.0-35.0nmol/L, Foresta: not reported, Willemse 2010: 8-35nmol/L, Murugaesu: 9-27 nmol/L, Ondrusova 2009: 12.0-28.0 nmol/L, Brown: 7.1-24.1nmol/L. / d FSH reference ranges: Willemse 2014: 2.0-10.0U/L, Foresta: not reported, Willemse 2010: 2.0-10.0U/L, Murugaesu: 1.0-10.0U/L, Brown: 2.0-18.1U/L. / e Estradiol reference ranges: Willemse 2010: 20-55 pmol/L, Isaksson: 13-90nmol/L, Willemse 2010: 20-55 nmol/L, Murugaesu: 17-50nmol/L. / g These outcomes were reported to be statistically significant in- or decreased, but p-values, means and SD or medians and ranges could not be retrieved. / TGCT Testicular germ cell tumor, NS nonsignificant, OE orchidectomy, RT radiotherapy, CT chemotherapy, LH luteinizing hormone, FSH follicle stimulating hormone, PTH para-thyroid hormone, SHBG sex hormone binding globulin, SD standard deviation, IQR inter quartile range, FU follow-up, VF vertebral fracture, n.d. not determined.

Figure 1 Study selection flow diagram according to the Preferred Reporting items for Systematic reviews and Meta-Analyses (PRISMA) guidelines.

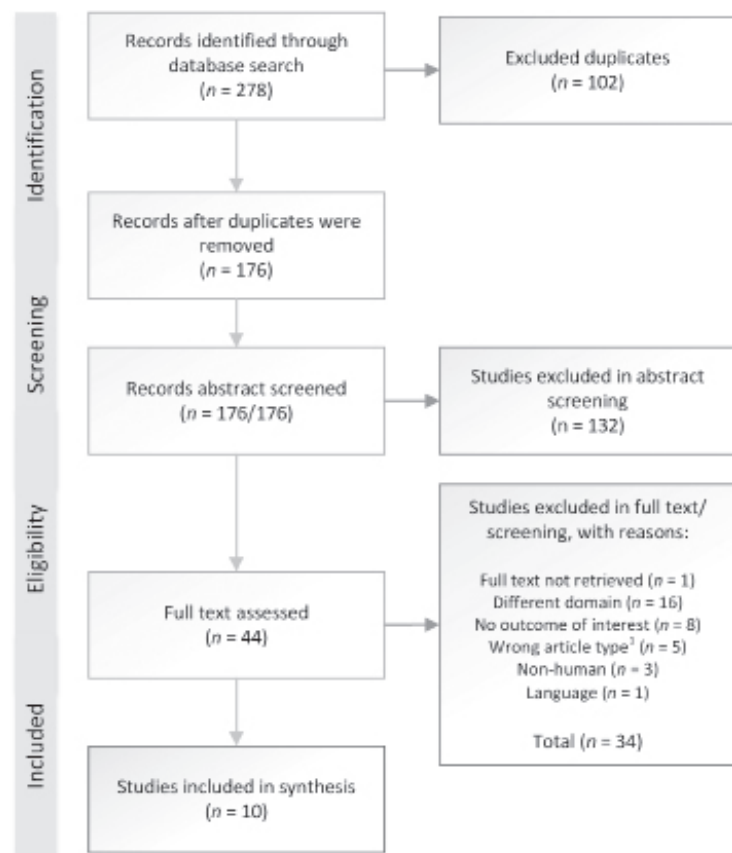

1 Wrong article types included case reports and reviews.

Figure 2 Risk of bias assessment for A: Individual studies and B: Across studies.

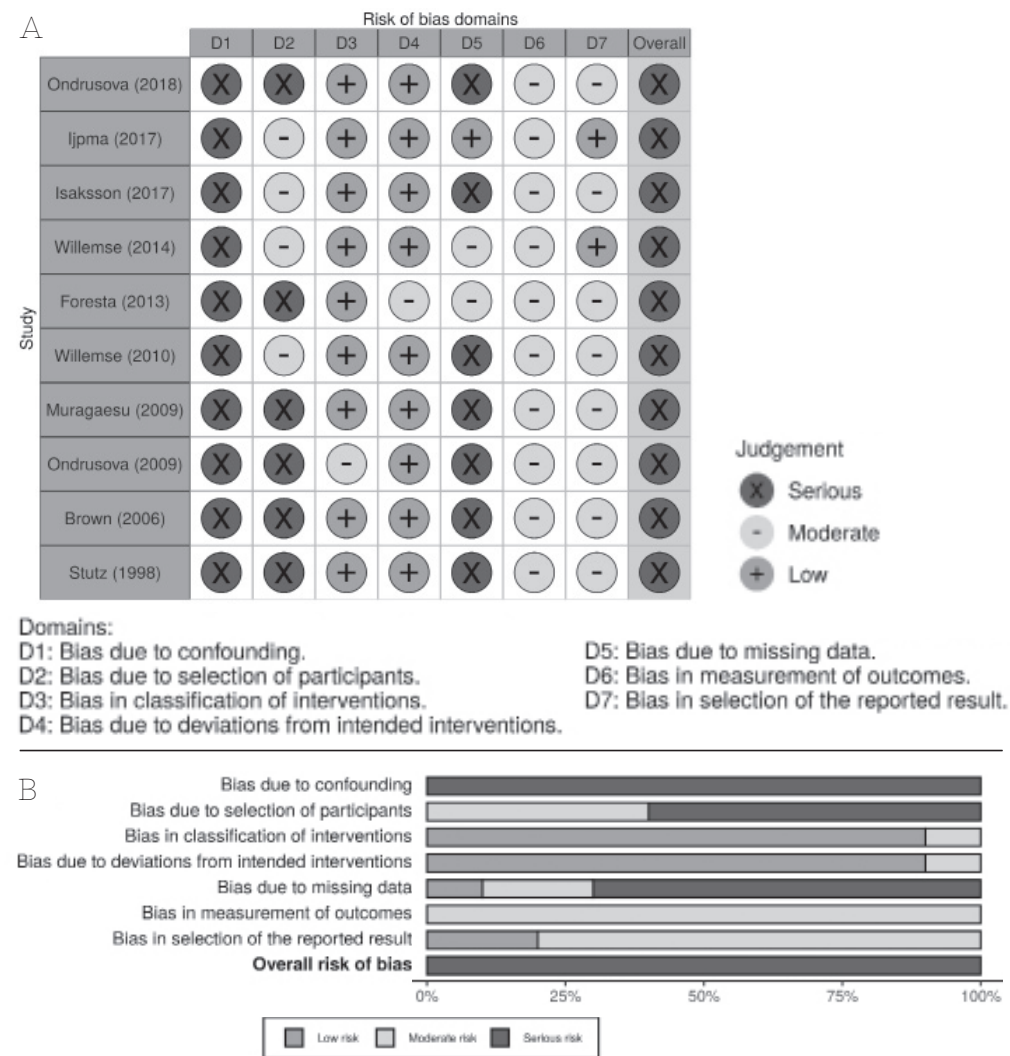

Based on the assessment of each domain, domain-level risk-of-bias judgement are 'low': comparable to a RCT with regard to this domain (grey), 'moderate' sound for a non-randomized study with regard to this domain, but cannot be considered comparable to a well-performed randomized trial (light-grey), 'serious': the study has some important problems in this domain (dark-grey), 'critical' the study is too problematic to provide any useful evidence and should not be included in any synthesis. The overall risk of bias is determined based on the assessment of all domains; as all studies had at least one domain with serious risk of bias (and none with a critical risk of bias), all studies must be assessed as having serious risk of bias.¹⁹

CHAPTER 3

Quantitative ultrasound of the calcaneus (QUS): a valuable tool in the identification of patients with non-metastatic prostate cancer requiring screening for osteoporosis

J.P.M. Vrouwe^{1,2}, B.B. Nieuwkamer^{1,3}, P.M. Willemse⁴, M.P.J. Nicolai^{5,6}, R.F.M. Bevers⁵, R.C.M. Pelger⁵, N.A.T. Hamdy⁷, S. Osanto¹

B.B. Nieuwkamer and J.P.M. Vrouwe contributed equally

Under review with Osteoporosis International

1 Leiden University Medical Center (LUMC), Leiden, NL – *Department of Medical Oncology*

2 Centre for Human Drug Research (CHDR), Leiden, NL

3 Reinier de Graaf Hospital (RdGG), Delft, NL – *Department of Urology*

4 University of Utrecht (UMCU), Utrecht, NL – *Department of Urology*

5 Leiden University Medical Center (LUMC), NL – *Department of Urology*

6 Netherlands Cancer Institute, NL – *Department of Urology*

7 Leiden University Medical Center, NL – *Department of Medicine, Division of Endocrinology, and Center for Bone Quality*

ABSTRACT

PURPOSE Non-metastatic prostate cancer (PCa) patients are at increased risk for osteoporosis and fractures mainly due to androgen deprivation therapy (ADT)-associated hypogonadism, but this remains largely underdiagnosed and undertreated. In this study, we examine the value of pre-screening calcaneal QUS in the identification of patients who should be referred for screening for osteoporosis using dual-energy x-Ray absorptiometry (DXA).

PATIENTS AND METHODS In a single-center cross-sectional study, all non-metastatic PCa patients attending our Uro-Oncological Clinic between 2011-2013 had DXA and calcaneal QUS measurements to assess positive (PPV) and negative (NPV) predictive value of QUS in identifying DXA-diagnosed osteoporosis (T-scores ≤ 2.5 and ≤ -2) at lumbar spine and/or femoral neck by analysis of receiver operating characteristic curves at QUS T-scores 0, -1.0, and -1.8

RESULTS We studied 256 patients, median age 70.9 (53.6-89.5) years, 93.0% of whom had local treatment and 84.4% ADT. Prevalence of osteoporosis and osteopenia was respectively 10.5% and 53%. Mean QUS T-score was -0.54 ± 1.58 . Whereas PPV of any QUS T-score was $< 25\%$, QUS T-scores between -1.0 and 0.0 had a NPV of $\geq 94.5\%$ for DXA T-scores ≤ 2.5 and ≤ -2 at any site, ruling out osteoporosis and significantly reducing the number of patients requiring DXA screening by up to two-third.

CONCLUSION Calcaneal QUS is an easy, inexpensive pre-screen tool with an excellent NPV for osteoporosis for osteoporosis in non-metastatic PCa. Pre-screening PCa patients with QUS allows the safe and cost-effective limitation of referrals for unnecessary DXA by confidently identifying patients least likely to have osteoporosis.

Introduction

Prostate cancer (PCa) is the second most common cancer in men worldwide, most frequently diagnosed above the age of 65 years.¹ Androgen deprivation therapy (ADT) is the mainstay of treatment for localized, locally advanced, as well as metastatic PCa^{2,3}, with treatment duration varying from < 3 years to life-long depending on the stage of the disease.²⁻⁴ ADT effectively prolongs overall survival⁵ but is always associated with a rapid decline in circulating gonadal hormones, in addition to the expected age-related decrease in gonadal function. This results in a disruption in bone remodelling, a decrease in bone mass and a deterioration in bone microarchitecture, and associated increased risk of fracture.⁶⁻⁸ Evidence from prospective studies show a significant decrease in bone mineral density (BMD) in the range of 2.4% to 5.6%, observed as early as 6 months and maximal in the first year of treatment with ADT,⁹⁻¹² with continuing further decreases in BMD on continuing treatment. The prevalence of osteoporosis has thus been reported to be 49% after 4 years of treatment, 66% after 8 years, and 81% after 10 or more years on continuous ADT.¹⁰ Two large U.S. cohort studies showed that fracture rates increased from about 6.5% per annum in PCa patients who do not receive ADT, to about 7.9% in those who do receive this treatment.^{13,14} It has been suggested that treatment with bisphosphonates may prevent the extent of BMD loss.^{11,12}

Dual-energy x-ray absorptiometry (DXA) is the gold standard for screening for osteoporosis, with the World Health Organization (WHO) reference standard for the diagnosis of osteoporosis outcomes expressed as T-scores, representing standard deviations from the mean in a young female adult reference population (NHANES).^{15,16} WHO criteria are used for the diagnosis of osteoporosis (T-score ≤ 2.5) at the femoral neck (FN) and lumbar spine (LS) and to respectively predict osteoporotic hip- and vertebral fractures.^{17,18}

For long, there had been no clear urological or medical oncological guidelines for screening bone health in PCa patients at the start or during treatment with ADT,^{19,20} until data from large cohort studies prompted awareness for the increased fracture risk observed in PCa patients undergoing this treatment.^{13,14} Although current Urological and oncological Societies' guidelines clearly recommend bone health surveillance using DXA in patients with PCa at the start of ADT,^{2,3,21,22} and the higher rates of osteoporosis and fragility fractures translate in increased morbidity, mortality and socio-economic burden in these patients,²³ it appears that bone health monitoring

still does not meet current guideline recommendations in patients with PCa who are treated with ADT.^{24–26}

Surveys conducted among urologists and oncologists revealed that physicians were not confident in screening for and managing osteoporosis in PCa patients.^{24,25} A Canadian study conducted in 22,033 men who received ADT for >12 months thus showed that although BMD screening rates had risen nearly 6-fold from 4.1% of patients in 2000 to 23.4% studied in 2015, there is still an unmet need for improving the diagnosis of osteoporosis, perhaps by using alternative screening strategies to overcome logistic and economic barriers of current strategies for osteoporosis screening.²⁵ DXA measurements of BMD are relatively expensive, and not always readily available. Calcaneal quantitative ultrasonography (QUS) is a practical, easy to use technique for bone mass measurement holding several potential advantages over DXA measurements by being portable, radiation-free and inexpensive. QUS could thus represent a simple, quick outpatient tool to pre-screen patients with PCa for osteoporosis, saving operator and patients' time and costs by avoiding referral for unnecessary DXA investigations.²⁷ Whereas pre-screening by QUS was found to be more cost-effective than screening with DXA in postmenopausal women,²⁸ there are to date no available data on the value of QUS in pre-screening large cohorts of PCa patients for osteoporosis.

The main objective of this study was to investigate the value of calcaneal QUS in identifying patients with non-metastatic PCa who require screening for osteoporosis using DXA, thus allowing the reduction of the number of unnecessary referrals for this investigation.

Patients and methods

PATIENT POPULATION

All patients with non-metastatic PCa treated with ADT who attended our Uro-oncological out-patient Clinic at the Leiden University Medical Center between November 2011 and May 2013 were included in this single centre cross-sectional study (Figure 1). Patients were treated for their prostate cancer using standardized protocols that followed up to date international guidelines.²⁹

All patients studied underwent an evaluation of their bone health, which included DXA BMD and calcaneal QUS measurements, performed within a week of each other, and a venepuncture for laboratory investigations including gonadal status and bone turnover markers.

Demographic and clinical data were retrieved from the patients' electronic medical records and included medical history, history of fractures and documentation of prevalent fractures, fracture risk factors such as previous fracture, family history for hip fracture, corticosteroid use, secondary causes for osteoporosis, smoking and alcohol consumption and records of osteoporosis treatment such as bisphosphonates or denosumab and use of calcium and vitamin D supplementation.

A telephone survey was conducted in 2019 in PCa survivors, in an extension of the study, to collect follow-up information on incident new fractures sustained in the years since the initial cross-sectional evaluation, on current use of ADT, and on use of osteoporosis medication such as bisphosphonates, denosumab and calcium and vitamin D (Figure 1).

BONE HEALTH EVALUATION

Bone mineral density measurements by DXA

BMD was measured at the LS (L1-L4) and at both FNs using dual energy X-ray absorptiometry scans (DXA, Hologic QDR 4500; Waltham, MA, USA) equipped with reference values based on the National Health and Nutrition Examination Surveys (NHANES),¹⁵ which are compatible with those of a Dutch control population. World Health organization (WHO) criteria were used to define osteopenia (T-score between -1 and -2.5) and osteoporosis (T-score \leq 2.5), based on the lowest T-score at any site. CV of the DXA measurements was established by repeated (approximately 1800) phantom measurements in our nuclear medicine department, leading to a CV of 2-3%, depending on the anatomic location. For all analyses, the left FN value (or contralateral hip in case of hip replacement) was used for all analyses. In addition to using the T-score of \leq 2.5, the WHO operational definition of osteoporosis, we also conducted an analysis of data using a DXA T-score of \leq -2.0 in order to minimize the chance of missing patients who may have an increased fracture risk at this higher cut-off point, especially because of the high likelihood of ADT-induced hypogonadism known to contribute to increased fracture risk by also compromising bone quality.^{30,31}

Quantitative ultrasound scanning of the calcaneus

QUS was performed by a dedicated experienced nurse at the left calcaneus site using the FDA approved Lunar Achilles ultrasound device (GE Healthcare LUNAR, Madison, Wisconsin, USA), which has a coefficient of variation <2.0%. Measurements obtained included Speed Of Sound (SOS) expressed

in meters/sec and Broad Band Attenuation (BUA) expressed in DB/MHZ. QUS results are expressed as T-score of the stiffness index, which is related to elasticity and mechanical stiffness, and bone strength, and takes into account both SOS and BUA (stiffness index = $(0.67 \times \text{BUA}) + (0.28 \times \text{SOS}) - 420$). The LUNAR Achilles ultrasound device was calibrated at regular intervals, according to manufacturer's instructions.

The randomly selected QUS T-scores of 0 and -1.0, and of -1.8 were used based on manufacturer's recommendations to study their predictability for the operational diagnosis of osteoporosis as defined by WHO criteria of BMD T-score ≤ 2.5 as well as the higher threshold of BMD T-score ≤ 2.0 , using ROC curves and the above selected QUS T-score cut-offs based on trade off of sensitivity and specificity.

Fragility Fractures

Data on prevalent fragility fractures including vertebral fractures, hip fractures and/or non-vertebral fractures at the time of the cross-sectional study were retrieved from the patients' electronic dossier.

Data on incident new fractures were obtained by telephone interview of PCa survivors at a fixed date spanning a week in 2019, between 5 and 7.5 years after initial evaluation. The date and type of the fracture and its radiological confirmation were retrieved from medical records when available.

LABORATORY INVESTIGATIONS

Laboratory investigations performed at the time of the cross-sectional evaluation of bone health included a routine biochemistry panel, gonadal status as assessed by plasma concentrations of total testosterone, luteinizing hormone, and sex hormone-binding globulin (SHBG), PSA, 25(OH)D3 vitamin D concentration (normal value $>50\text{nmol/l}$), and bone turnover markers including the bone formation marker: N-terminal pro-peptide of type 1 procollagen (P1NP, normal value $<59\text{ ng/ml}$) and the bone resorption marker: beta-carboxyl-terminal cross-linking telopeptide of type I collagen (β -CTX, normal value $<0.85\text{ ng/ml}$)

STATISTICAL ANALYSIS

SPSS 28 for Windows software package (SPSS Inc., Chicago, IL, USA) was used for statistical analysis. The χ^2 -test for categorical variables and Student's T-test or Mann-Whitney test (two-sided) for non-normally distributed variables were used as appropriate. Data are presented as mean \pm SD, median

and range, or as percentages A p -value of <0.05 (two-tailed) was considered statistically significant. Correlation analysis was performed using a two-tailed Pearson correlation coefficient with a significance level of $p < 0.05$. Negative predictive value (NPV) and positive predictive value (PPV) were calculated for various QUS T-score thresholds compared to WHO BMD T-score ≤ 2.5 -defined osteoporosis and BMD T-score ≤ 2.0 .

Receiver operating characteristic (ROC) curve analysis was used to evaluate the discriminatory ability of QUS to detect osteoporosis at lumbar spine and femoral neck as measured by DXA. The area under the curve (AUC) was calculated for available DXA sites with a confidence interval of 95%. The area under the curve (AUC) was also calculated for a DXA T-score of ≤ 2.0 at lumbar spine and femoral neck for the ROC curve analysis. Two-tailed $p < .05$ was considered statistically significant.

Results

CROSS-SECTIONAL STUDY

Demographic data

Baseline characteristics of the 256 non-metastatic PCa patients studied, including age, body mass index and clinical risk factors for osteoporosis, are shown in Table 1. Median age was 71.3 years, range 53.6-89.5. 238 men (93.0%) were treated with local radiotherapy to the prostate (80.1%) or prostatectomy (12.9%) and the majority (216, 84.4%) had received ADT for up to 3 years prior to the cross-sectional study (average 24 months): 44 patients (17.2%) had received ADT for less than 6 months, and 172 (67.2%) received ADT for a period of 6 to 36 months at the time of the evaluation, at which time only five patients (2%) were using a bisphosphonate \pm calcium and vitamin D supplements as treatment for a documented osteoporosis (Table 1). Clinical risk factors for osteoporosis are also detailed in Table 1.

BONE MEASUREMENTS

DXA

Mean DXA T-scores at LS and FN were respectively -0.47 ± 1.46 SD, median -0.60 (range: $-4.20 - 4.00$) and -1.03 ± 0.93 , median -1.20 (range: $-3.20 - 2.50$). 136 Patients (53.1%) had osteopenia (T-score ≤ -1.0 to ≥ -2.5) at either LS or FN: 5.9% at the LS alone, and 29.7% at the FN alone. Twenty-seven patients (10.5%) had osteoporosis (T-score < -2.5) at either the lumbar spine or the femoral neck: 17 (6.6%) at LS alone, and 15 (5.8%) at FN alone.

Thirty-nine patients (15.2%) had a DXA T-score of ≤ 2.0 at the spine, and 58 (22.6%) at either left or right FN. Overall, 75 (29.2%) patients had a DXA T-score of ≤ 2.0 at any measured bone site.

BMD outcomes of the 40 patients who did not receive ADT were not significantly different from the 216 patients who did.

QUS

Mean T-score for QUS was -0.54 ± 1.58 SD, median -0.65 (range: -3.70 - 4.00). Of the total 256 PCa patients evaluated, 170 (66.4%) had a QUS T-score ≤ 0 , 108 (42.2%) had scores ≤ -1.0 , and 56 (21.9%) had scores of ≤ -1.8 (Table 2).

Prevalent fractures

Only eleven of the 256 patients (4.2%), median age 76.6 (range 58.9-83.8) years, had documented prevalent fragility fractures at the time of the cross-sectional study (Table 1). Four patients had a vertebral fracture (one each with 1,2,3 and 4 VF, respectively), one had a hip fracture in addition to 2 VFs and 4 rib fractures. Five patients had sustained non-vertebral fractures (humerus, femur, pelvis, ribs, shoulder). Only 3 of these 11 patients had osteoporosis (1 at LS, and 2 at FN).

Median QUS T-score was -2.10 , range -3.40 to 3.80 . Nine of 11 patients had a QUS T-score < 0 , and six had a QUS T-score ≤ -2.0 (range -3.40 to -2.10).

All 11 patients had normal β -CTX measurements, 3 had slightly elevated P1NP plasma levels (data not shown), and in all fractures occurred 1 to 25 years after the start of their ADT treatment.

LABORATORY MEASUREMENTS

Receiver Operating Curve (ROC)

There was a moderate correlation between T-scores as measured by calcaneal QUS and DXA T-score at the LS ($r=0.43$; $p<0.001$) and at the FN ($r=0.46$; $P<0.001$).

PREDICTIVE VALUE OF QUS FOR OSTEOPOROSIS

Frequencies of patients without osteoporosis (DXA T-scores ≤ -1.0 > -2.5) and with osteoporosis (DXA T-scores ≤ -2.5) at LS, FN or either LS or FN and corresponding distribution of three different QUS T-score thresholds 0, -1.0 and -1.8 are shown in Table 2.

The NPVs and PPVs for the three QUS T-score thresholds of 0, -1.0 and -1.8 are shown in Table 3. All NPVs for osteoporosis at either LS and/or FN

were $\geq 94.5\%$ and did not change significantly when varying the QUS T-score threshold value between 0 and -1.8 (Table 3). In contrast, PPV's were only $< 25\%$ at any QUS T-score. A QUS threshold of -1.0 to 0.0 would thus lead to a 34.0 to 57.8% reduction of DXAs required to diagnose osteoporosis.

ROC curves were constructed for QUS T-scores using DXA T-scores of ≤ 2.5 , and for DXA T-scores of ≤ 2.0 . The latter are shown in Figure 2 respectively for lumbar spine (left panel; AUC 0.731, p-value < 0.001), for femoral neck (middle panel; AUC 0.753, p-value 0.002) and for any site (right panel; AUC 0.725, p-value < 0.001).

The area under the curve (AUC) for QUS T-Scores using DXA T-score of ≤ 2.5 were not different, namely for lumbar spine: AUC of 0.739, p-value 0.001; for femoral neck: AUC 0.753, p-value 0.753 and for any site: AUC of 0.725, p-value of < 0.001 .

FOLLOW-UP DATA ANALYSIS (TELEPHONE INTERVIEW)

A follow up telephone interview could be conducted in 155 of 163 survivors (Figure 1). Of these 155 patients, 11 (7%) were on ADT for biochemical recurrence or metastases.

Forty-two patients (27.1%) reported episodes of sudden back pain, of whom 5 (3.2%) had radiologically confirmed vertebral fractures (VF). Among survivors in remission from their PCa, 15 reported radiologically confirmed fractures; 11 (7.1%) after adequate and 4 (2.6%) after inadequate trauma. Initial QUS T-scores of the 4 fracture patients were low (median -3.05 , range -3.6 – 0.2), and only one would have been diagnosed with osteoporosis based on LS/FN DXA T-scores. One of 4 survivors with an incident fracture at follow up also had a prevalent fracture at baseline. His baseline DXA showed normal BMD at LS and osteopenia in the FN, whereas calcaneal QUS T-score was -3.40 .

Discussion

Findings from our cross-sectional study of 256 non-metastatic PCa patients followed in the out-patient clinic of our uro-oncological clinic, confirm a diagnosis of osteoporosis based on a WHO DXA T-score of ≤ -2.5 to be present in 10.5 %, and of osteopenia in 53.1% of patients, despite the majority (84.4%) having been on ADT at some stage prior to the study or were currently using this therapy for at least 6 months. A DXA T-score of ≤ -2.0 , a cut-off we chose to include in the analysis because of the high likelihood of

ADT-induced hypogonadism, which may not only contribute to a decrease in BMD, but also to a BMD-independent decrease in bone quality, both increasing fracture risk, was present in 29.2% of patients.

The high worldwide prevalence of PCa, and the high percentage of PCa patients who will receive treatment with ADT and will be at high risk for osteoporosis and fractures, raises the need for a simple outpatient selection tool to enable the identification of patients who require screening for osteoporosis and thus reduce the number of unnecessarily referrals for DXA. Whereas DXA measurements remain the gold standard for osteoporosis screening,³³ the investigation is costly, not always (readily) available and fractures may occur at T-scores thresholds higher than the operational diagnostic threshold ≤ -2.5 particularly in the presence of factors potentially affecting bone quality such as hypogonadism. Low threshold, cheaper and faster, screening methods such as QUS have been found to be cost-effective,²⁸ and could improve the screening rate for osteoporosis, ultimately resulting in improvement of the economic and patient burden of osteoporosis.³²

DXA and QUS measure different aspects of bone strength. Whereas DXA measures bone mineral density and content, reflecting material properties of bone, QUS measures trabecular sound transmission reflecting trabecular microarchitecture and thus structural properties of bone, both important components of bone quality and thus bone strength, thus representing potentially complementary tools in the prediction of fracture risk. Others found a moderate correlation between DXA T-scores and QUS outcomes in prostate cancer patients.³³ Previous studies conducted in healthy men and women showed that QUS was at least comparable to DXA for predicting fractures in healthy men and women^{34,35}. In two 10-year prospective studies, one including 3,883 postmenopausal women, the second including 1,511 men and women aged ≥ 65 years, QUS was shown to be able to predict future "osteoporotic" fractures equally or better compared to DXA.^{34,35} In another study of osteoporotic fractures conducted in 5,607 men aged ≥ 65 years recruited from six US centres, QUS measurements predicted the risk of hip and any non-vertebral fracture in older men, nearly as well as hip BMD measurements, although combined measurements of QUS and BMD were not superior to either measurement alone.³⁶

The main objective of our study was to evaluate the pence of QUS in identifying non-metastatic PCa patients found to have osteoporosis using the DXA WHO criteria (BMD T-scores of ≤ -2.5), or those potentially at risk for fracture at a higher T-score threshold of ≤ -2.0 , and to establish the QUS cut-off

T-score threshold correlating best with these DXA T-scores to allow the targeted selection of patients requiring DXA referral for screening for osteoporosis. Applying device-specific QUS T-score thresholds between 0 and -1 established a certainty level high enough to rule out osteoporosis in non-metastatic PCa patients, with NPVs for DXA-based osteoporosis at any site being $\geq 94.5\%$, translating in significantly limiting the need for referral for a diagnostic DXA for osteoporosis in up to two-third of patients, with an acceptable low osteoporosis misclassification rate of $<6\%$.

To our knowledge, this is the second study addressing the value of QUS compared to DXA in the diagnosis of osteoporosis in PCa patients. A first study conducted in 60 PCa patients,³³ showed that a QUS threshold T-score ≤ -0.5 would avoid performing 21 (35%) of DXA scans at the cost of missing one case (5.6%) compared with DXA T-score of ≤ -2.0 (NPV 95%).³³

Our findings from this cross-sectional study conducted in a much larger cohort of non-metastatic PCa patients show that although QUS represents an attractive pre-screen tool to rule out a diagnosis of osteoporosis in these patients, as shown by the very high negative predictive value of QUS T-score thresholds of 0, -1 and -1.8 (94.5% to 97.7%) for osteoporosis, the low positive predictive value of this tool for osteoporosis ($<25\%$) indicates that QUS lacks specificity to replace DXA in establishing a diagnosis of osteoporosis in these patients.

Our cross-sectional study has strengths as well as limitations. Its main strength is the relatively large cohort of strictly non-metastatic PCa patients, treated in a single centre, using standardized protocols following international guidelines, the majority at whom were at risk for osteoporosis and fractures due to ADT-induced hypogonadism and all had DXA and QUS investigations at no longer than a week interval. Exclusion of metastatic PCa disease is also a strength of our study, as it avoids potentially falsely increased BMD measurements at lumbar spine and/or femoral neck, due to PCa metastases frequently harboured at these sites ($\sim 90\%$ of cases). In contrast, calcaneal QUS measurements remain unaffected by metastatic disease as calcaneal bone is a very rare site of bone metastases in PCa.

Our study also has limitations, the main of which is that the number of prevalent fractures at the time of initial evaluation and the number of incident new fractures self-reported by survivors at the time of the telephone survey may have underestimated the actual number of vertebral fractures and their grades as thoracic and lumbar spinal radiology was not systematically performed at the time of the cross-sectional evaluation or at any time

thereafter, so that silent non-clinical vertebral fractures, which often occur in patients with secondary osteoporosis may have been missed. Incident fractures were also self-reported and radiological confirmation was not always available from the patients' medical records. These limitations precluded reaching any reliable conclusion on the value of DXA, of QUS or a combination of the two in the prediction of fracture risk in patients with non-metastatic PCa who are at high risk for these fractures because of ADT-associated hypogonadism. A further general limitation of the study is that QUS instruments have a relatively high variation coefficient and that consequently, results obtained using a specific device may not be extrapolated to another device or to absolute QUS device thresholds.³⁷

In conclusion, our data show that although QUS may not be used for the diagnosis of osteoporosis as traditionally defined by WHO criteria in non-metastatic PCa patients, we provide evidence that outpatient pre-screening for osteoporosis using a device-specific threshold of QUS T-scores represents a simple, convenient, cost-effective tool, confidently ruling out patients who are highly unlikely to have osteoporosis. This outcome translates in a significant reduction in the number of patients requiring DXA screening for osteoporosis by up to two-third, with an acceptably low osteoporosis misclassification of 6%. The potential ability of QUS to measure a feature of bone quality predictive of fracture risk not captured by DXA BMD measurements remains to be established in future studies specifically designed to address this interesting issue.

REFERENCES

- Siegel RL, Miller KD, Jemal A. Cancer statistics, 2020. *CA Cancer J Clin.* 2020;70(1):7-30. doi:10.3322/caac.21590
- Cornford P, van den Bergh RCN, Briers E, et al. EAU-EANM-ESTRO-ESUR-SIOG Guidelines on Prostate Cancer. Part II—2020 Update: Treatment of Relapsing and Metastatic Prostate Cancer. *European Urology.* Published online 2020. doi:10.1016/j.eururo.2020.09.046
- Lowrance WT, Breau RH, Chou R, et al. Advanced Prostate Cancer: AUA/ASTRO/SUO Guideline PART I. *Journal of Urology.* Published online September 22, 2020. doi:10.1097/jju.0000000000001375
- Sanda MG, Cadeddu JA, Kirkby E, et al. Clinically Localized Prostate Cancer: AUA/ASTRO/SUO Guideline. Part I: Risk Stratification, Shared Decision Making, and Care Options. *Journal of Urology.* 2018;199(3):683-690. doi:10.1016/j.juro.2017.11.095
- Bolla M, Descotes JL, Artignan X, Fournier P. Adjuvant treatment to radiation: combined hormone therapy and external radiotherapy for locally advanced prostate cancer. *BJU International.* 2007;100(s2 Prostate Cancer):44-47. doi:10.1111/j.1464-410X.2007.06954.x
- Badri el SAM, Salawu A, Brown JE. Bone Health in Men with Prostate Cancer: Review Article. *Curr Osteoporosis Rep.* 2019;17(6):527-537. doi:10.1007/s11914-019-00536-8
- Dalla Via J, Daly R, Owen P, Mundell N, Rantalainen T, Fraser S. Bone mineral density, structure, distribution and strength in men with prostate cancer treated with androgen deprivation therapy. *Bone.* 2019;127:367-375. doi:10.1016/j.bone.2019.06.005
- Looker AC, Borrud LG, Hughes JP, Fan B, Shepherd JA, Melton LJ. Lumbar spine and proximal femur bone mineral density, bone mineral content, and bone area: United States, 2005-2008. *Vital and health statistics Series 11, Data from the national health survey.* 2012;(251):1-132.
- Greenspan S, Coates P, Sereika S, Nelson J, Trump D, Resnick N. Bone loss after initiation of androgen deprivation therapy in patients with prostate cancer. *J Clin Endocrinol Metab.* 2005;90(12):6410-6417. doi:10.1210/JC.2005-0183
- Morote J, Morin J, Orsola A, et al. Prevalence of osteoporosis during long-term androgen deprivation therapy in patients with prostate cancer. *Urology.* 2007;69(3):500-504. doi:10.1016/j.urology.2006.11.002
- Alibhai SMH, Zukotynski K, Walker-Dilks C, et al. Bone Health and Bone-targeted Therapies for Prostate Cancer: a Programme in Evidence-based Care — Cancer Care Ontario Clinical Practice Guideline. *Clinical Oncology.* 2017;29(6):348-355. doi:10.1016/j.clon.2017.01.007
- Choo R, Lukka H, Cheung P, et al. Randomized, double-blinded, placebo-controlled, trial of risedronate for the prevention of bone mineral density loss in nonmetastatic prostate cancer patients receiving radiation therapy plus androgen deprivation therapy. *Int J Radiat Oncol Biol Phys.* 2013;85(5):1239-1245. doi:10.1016/j.ijrobp.2012.11.007
- Shahinian VB, Kuo YF, Freeman JL, Goodwin JS. Risk of Fracture after Androgen Deprivation for Prostate Cancer. *New England Journal of Medicine.* 2005;352(2):154-164. doi:10.1056/NEJMOA041943
- Smith M, Boyce S, Moynour E, Duh M, Raut M, Brandman J. Risk of clinical fractures after gonadotropin-releasing hormone agonist therapy for prostate cancer. *The Journal of Urology.* 2006;175(1):136-139. doi:10.1016/S0022-5347(05)00033-9
- Looker AC, Borrud LG, Hughes JP. Vital and Health Statistics Lumbar Spine and Proximal Femur Bone Mineral Density, Bone Mineral Content, and Bone Area: United States, 2005-2008: data from the National Health and Nutrition Examination Survey. *Vital Health Stat.* 2012;251(11):2005-2008.
- World Health Organization. WHO Scientific Group on the Assessment of Osteoporosis at Primary Health. *World Health Summary Meeting Report Brussels, Belgium, 2004.* 2007;May(May 2004):1-13.
- Johnell O, Kanis JA, Oden A, et al. Predictive Value of BMD for Hip and Other Fractures. *Journal of Bone and Mineral Research.* 2007;22:774. doi:10.1359/JBMR.050304
- Schuit SCE, van der Klift M, Weel AEAM, et al. Fracture incidence and association with bone mineral density in elderly men and women: The Rotterdam Study. *Bone.* 2004;34(1):195-202. doi:10.1016/j.bone.2003.10.001
- Mottet N, Bellmunt J, Bolla M, et al. EAU guidelines on prostate cancer. Part II: Treatment of advanced, relapsing, and castration-resistant prostate cancer. *European Urology.* 2011;59(4):572-583. doi:10.1016/j.eururo.2011.01.025
- Coleman R, Body JJ, Aapro M, Hadji P, Herrstedt J. Bone health in cancer patients: ESMO clinical practice guidelines. *Annals of Oncology.* 2014;25:124-137. doi:10.1093/annonc/mdu103
- Saylor P, Rumble R, Tagawa S, et al. Bone Health and Bone-Targeted Therapies for Prostate Cancer: ASCO Endorsement of a Cancer Care Ontario Guideline. *Journal of Clinical Oncology.* 2020;38(15):1736-1743. doi:10.1200/JCO.19.03148
- Parker C, Castro E, Fizazi K, et al. Prostate cancer: ESMO Clinical Practice Guidelines for diagnosis, treatment and follow-up. *Annals of Oncology.* 2020;31(9):1119-1134. doi:10.1016/j.annonc.2020.06.011
- Clynes MA, Harvey NC, Curtis EM, Fuggle NR, Dennison EM, Cooper C. The Epidemiology of Osteoporosis. doi:10.1093/bmb/ldaa005

24 Heidenreich A, Witjes W, Bjerklund-Johansen T, Patel A. Therapies used in prostate cancer patients by European urologists: data on indication with a focus on expectations, perceived barriers and guideline compliance related to the use of bisphosphonates. *Urologica internationalis*. 2012;89(1):30-38. doi:10.1159/000338810

25 Damji A, Bies K, Alibhai S, Jones J. Bone health management in men undergoing ADT: examining enablers and barriers to care. *Osteoporosis International*. 2015;26(3):951-959. doi:10.1007/S00198-014-2997-6

26 Hu J, Aprikian A, Vanhuysse M, Dragomir A. Contemporary Population-Based Analysis of Bone Mineral Density Testing in Men Initiating Androgen Deprivation Therapy for Prostate Cancer. *Journal of the National Comprehensive Cancer Network*. 2020;18(10):1374-1381. doi:10.6004/JNCCN.2020.7576

27 Hans D, Baim S. Quantitative Ultrasound (QUS) in the Management of Osteoporosis and Assessment of Fracture Risk. *Journal of Clinical Densitometry*. 2017;20(3):322-333. doi:10.1016/j.jocd.2017.06.018

28 Nayak S, Roberts MS, Greenspan SL. Cost-Effectiveness of Different Screening Strategies for Osteoporosis in Postmenopausal Women. *Annals of Internal Medicine*. 2011;155(11):751. doi:10.1059/0003-4819-155-11-20112060-00007

29 Mottet N, van den Bergh RCN, Briers E, et al. EAU-EANM-ESTRO-ESUR-SIOG Guidelines on Prostate Cancer-2020 Update. Part 1: Screening, Diagnosis, and Local Treatment with Curative Intent. *Eur Urol*. 2021;79(2):243-262. doi:10.1016/j.eururo.2020.09.042

30 Kanis JA, Bianchi G, Bilezikian JP, et al. Towards a diagnostic and therapeutic consensus in male osteoporosis. *Osteoporosis International*. 2011;22(11):2789-2798. doi:10.1007/s00198-011-1632-z

31 Binkley N, Adler R, Bilezikian JP. Osteoporosis diagnosis in men: The T-score controversy revisited. *Current Osteoporosis Reports*. 2014;12(4):403-409. doi:10.1007/s11914-014-0242-z

32 Hernlund E, Svedbom A, Ivergård M, et al. Osteoporosis in the European Union: Medical management, epidemiology and economic burden: A report prepared in collaboration with the International Osteoporosis Foundation (IOF) and the European Federation of Pharmaceutical Industry Associations (EFPIA). *Archives of Osteoporosis*. 2013;8(1-2):136. doi:10.1007/s11657-013-0136-1

33 van Casteren-Messidoro C, Huisman AM, Birnie E, van Gelder M, van de Geijn FE, Hamberg P. Quantitative ultrasound of the heel as triage test to measure bone mineral density compared with dual energy X-ray absorptiometry in men with prostate cancer commencing with androgen deprivation therapy. *Neth J Med*. 2014;72(10):528-532. Accessed August 14, 2017. <http://www.ncbi.nlm.nih.gov/pubmed/26219758>

34 Stewart A, Kumar V, Reid D. Long-term fracture prediction by DXA and QUS: a 10-year prospective study. *Journal of Bone and Mineral Research*. 2006;21(3):413-418. doi:10.1359/JBMR.051205

35 Moayyeri A, Kaptoge S, Dalzell N, et al. Is QUS or DXA Better for Predicting the 10-Year Absolute Risk of Fracture? *Journal of Bone and Mineral Research*. 2009;24(7):1319-1325. doi:10.1359/JBMR.090212

36 Bauer D, Ewing S, Cauley J, Ensrud K, Cummings S, Orwoll E. Quantitative ultrasound predicts hip and non-spine fracture in men: the MrOS study. *Osteoporosis International*. 2007;18(6):771-777. doi:10.1007/S00198-006-0317-5

37 Njeh CF, Hans D, Li J, et al. Comparison of six calcaneal quantitative ultrasound devices: precision and hip fracture discrimination. *Osteoporosis Int*. 2000;11(12):1051-1062. doi:10.1007/S001980070027

Table 1 Patient demographics

	All Patients		Normal BMD		Osteopenia		Osteoporosis		Normal BMD vs. osteopenia		Normal BMD vs. osteoporosis/osteopenia		Fragility Fractures #	
	Mean ± SD	Median (range)	Mean ± SD	Median (range)	Mean ± SD	Median (range)	Mean ± SD	Median (range)	p	p	Mean ± SD	Median (range)	Mean ± SD	Median (range)
N	256		93 (36.3%)		136 (53.1%)		27 (10.5%)							
Patient Characteristics														
Age at time of bone measurements (yrs)	70.9 ± 6.6	71.3 (53.6-89.5)	69.1 ± 6.5	70.3 (53.6-86.7)	71.4 ± 6.4	72.1 (54.9 - 89.5)	74.0 ± 6.3	74.7 (58.9-85.2)	p = 0.007	p = 0.001	p = 0.001	p = 0.001	75.5 ± 6.8	76.6 (58.9-83.8)
Time between primary treatment for PCa and bone measurements (yrs)	3.2 ± 3.1	2.4 (0-17.5)	2.9 ± 2.7	1.9 (0 - 11.7)	3.3 ± 3.3	2.4 (0.0 - 17.5)	1.56 ± 0.7	2.0 (0-4.0)	NS	NS	NS	NS	4.5 ± 4.8	3.7 (0.2-17.4)
BMI (kg/m ²)	27.1 ± 3.3	26.9 (20.1-37.4)	28.1 ± 3.1	27.8 (22.3-35.9)	26.7 ± 3.2	26.5 (20.1 - 37.4)	25.4 ± 3.3	24.7 (20.5-33.3)	p = 0.002	p < 0.001	p < 0.001	p < 0.001	27.2 ± 2.5	26.5 (22.9-30.3)
Risk factors														
Obesity N (%)	50 (19.7)		33 (18.8)		15 (22.4)		2 (18.2)		NS	NS	NS	NS	2 (18.2)	
Corticosteroid use N (%)	14 (5.5)		3 (3.2)		11 (8.1)		0 (0.0)		NS	NS	NS	NS	1 (9.1)	
Smoking N (%)	32 (12.6)		13 (14.1)		17 (12.6)		2 (7.7)		NS	NS	NS	NS	1 (9.1)	
Alcohol abuse (≥3 units/day) N (%)	60 (23.8)		30 (33.0)		27 (20.0)		3 (11.5)		p = 0.03	p = 0.03	p = 0.01	p = 0.01	4 (36.4)	

All Patients	Normal BMD	Osteopenia	Osteoporosis	Normal BMD vs. osteopenia	Normal BMD vs. osteoporosis	Normal BMD vs. osteoporosis/osteopenia	Fragility Fractures #
N = 256	N = 93 (36.3%)	N = 136 (53.1%)	N = 27 (10.5%)	NS	NS		
Local treatment N (%)	238 (93.0)						
Radical prostatectomy N (%)	33 (12.9)	15 (5.9)	2 (0.8)				
EBRT N (%)	182 (71.1)	100 (39.1)	21 (8.2)				
Brachytherapy N (%)	23 (9.0)	11 (4.3)	2 (0.8)				
No prior ADT N (%)	40 (15.6)	19 (13.9)	2 (7.4)	NS	NS		0 (0.0)
Prior or current ADT N (%)	216 (84.4)	117 (86.0)	25 (92.6)	NS	NS		11 (100)
≤ 6 months N (%)	44 (17.2)	23 (16.9)	6 (22.2)				2 (18.2)
6-36 months* N (%)	172 (67.2)	94 (69.1)	19 (70.4)				9 (81.8)
Prior use of bone protective agents							
Bisphosphonates (oral) N (%)	5 (2.0)	3 (0.22)	1 (0.03)	NS	NS		1 (9.1)

Normal BMD: DXA T-score > -1 at femoral neck and lumbar spine; Osteopenia: DXA -2.5 < T-score < -1 in femur and/or lumbar spine; Osteoporosis: DXA T-score ≤ -2.5 in femur and/or lumbar spine DXA-measurements. Obesity defined by a BMI > 30 kg/m² / * We lumped together ADT treatment periods which varied between 6 months and the maximal period of 3 years as long-lasting castrate levels of testosterone are induced already after 6 months of ADT / # Eighteen patients (7.0%) were unwilling or unable to receive any form of local treatment and received ADT only. / Reasons for (oral) bisphosphonate therapy: known osteoporosis (N=2), rheumatoid arthritis (N=1), or unknown (N=2). / # Two (48.1%) of the 11 patients with fragility fractures, had osteoporosis: one at the LS, another at the FN. Three of the 11 patients with fractures had slightly elevated P1NP, whereas all 11 patients had β-CTX measurements in the normal range. / PCA prostate cancer, ADT androgen deprivation therapy, EBRT External beam radiotherapy

Table 2 Frequencies of patients without (DXA T-scores ≥ -2.5) and with osteoporosis (DXA T-scores ≤ -2.5) at LS, FN or either LS or FN according to QUS T-score thresholds 0, -1.0 and -1.8.

		Calcaneal QUS							
		T-score > 0	T-score ≤ 0	T-score > -1.0	T-score ≤ -1.0	T-score > -1.8	T-score ≤ -1.8	Total	
DXA measurements	LS	T-score > -2.5 (N)	84	155	144	95	193	46	239
		T-score ≤ -2.5 (N)	2	15	4	13	7	10	17
	FN	T-score > -2.5 (N)	83	158	143	98	194	47	241
		T-score ≤ -2.5 (N)	3	12	5	10	6	9	15
	LS and/or FN	T-score > -2.5 (N)	82	147	141	88	189	40	229
		T-score ≤ -2.5 (N)	4	23	7	20	11	16	27
Total		86	170	148	108	200	56	256	

QUS quantitative ultrasonography, DXA dual-energy absorptiometry, LS Lumbar spine, FN Femoral neck. / * For QUS of the left calcaneus and for DXA BMD of the Femoral Neck the lowest T-score value of either left or right hip was used (in patients with a hip replacement, the contralateral hip was used).

Table 3 Negative and positive predictive values for the three QUS T-score thresholds shown.

		DXA T-score ≤ -2.5	Calcaneal QUS		
			T-score < 0	T-score ≤ -1	T-score ≤ -1.8
DXA	LS	NPV	97,7%	97,3%	96,5%
		PPV	8,8%	12,0%	15,2%
	FN	NPV	97,7%	96,6%	97,0%
		PPV	8,8%	9,3%	13,8%
	LS and/or FN	NPV	95,3%	95,3%	94,5%
		PPV	13,5%	18,5%	22,2%

QUS quantitative ultrasonography, DXA dual-energy absorptiometry, LS Lumbar spine, FN Femoral neck, NPV negative predictive value, PPV positive predictive value. Details of DXA T-score of ≤ 2.0 as shown by Receiver operating characteristic (ROC) curves are shown in Figure 2

Figure 1 Cross-sectional study (n=256) and follow up study in long-term survivors (n=155). Flow diagram of patients included in the initial cross-sectional study, and follow up data obtained by telephone survey, and reasons for not performing follow-up.

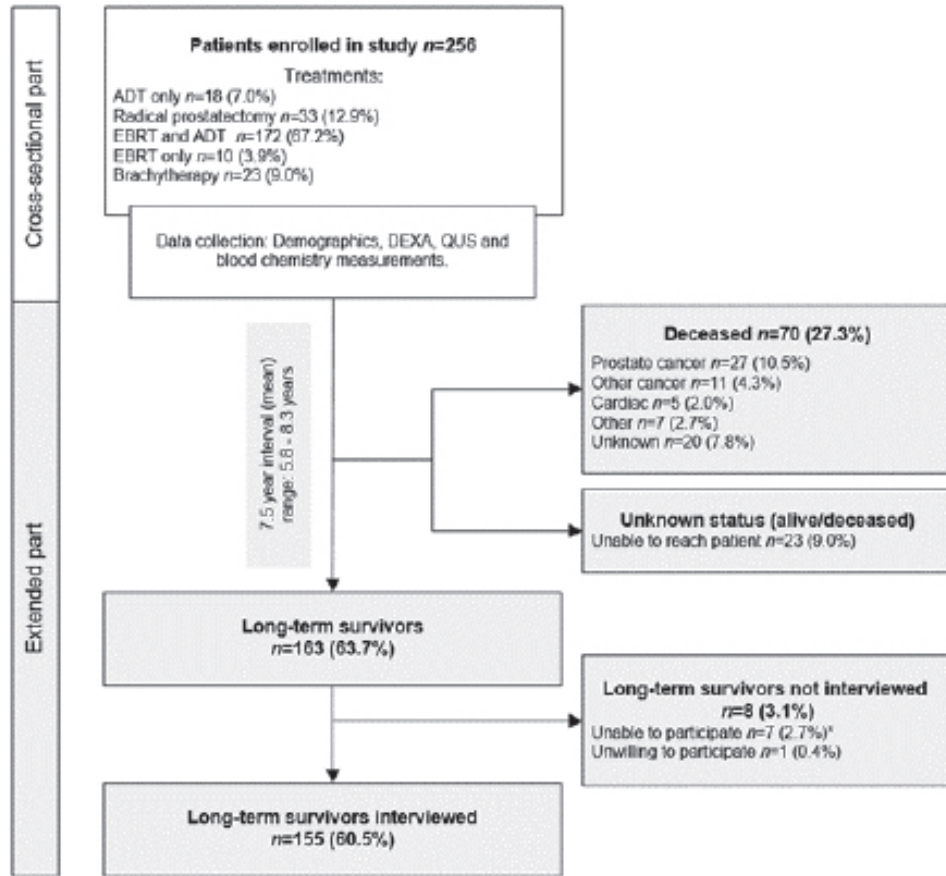

* Patients with confirmed cognitive disorders unable to take part in the survey.

Figure 2 Receiver operating characteristic (ROC) curves for DXA T-score of ≤ 2.0 .

The figure displays ROC curves for Lumbar Spine (left panel; AUC 0.731, P value <0.001, and 95% CI 0.65-0.81), Femoral Neck (middle panel, AUC 0.736, P value <0.001 and 95% CI 0.66-0.81) and Any Site (right panel; AUC 0.736, P value 0.001, and 95% CI 0.66-0.81). The diagonal line indicates a reference area under the curve (AUC) of 0.50 (no better than chance alone). Receiver operating characteristic (ROC) curves for DXA T-score of ≤ 2.0 . Details of DXA T-score of ≤ 2.5 shown in Table 3.

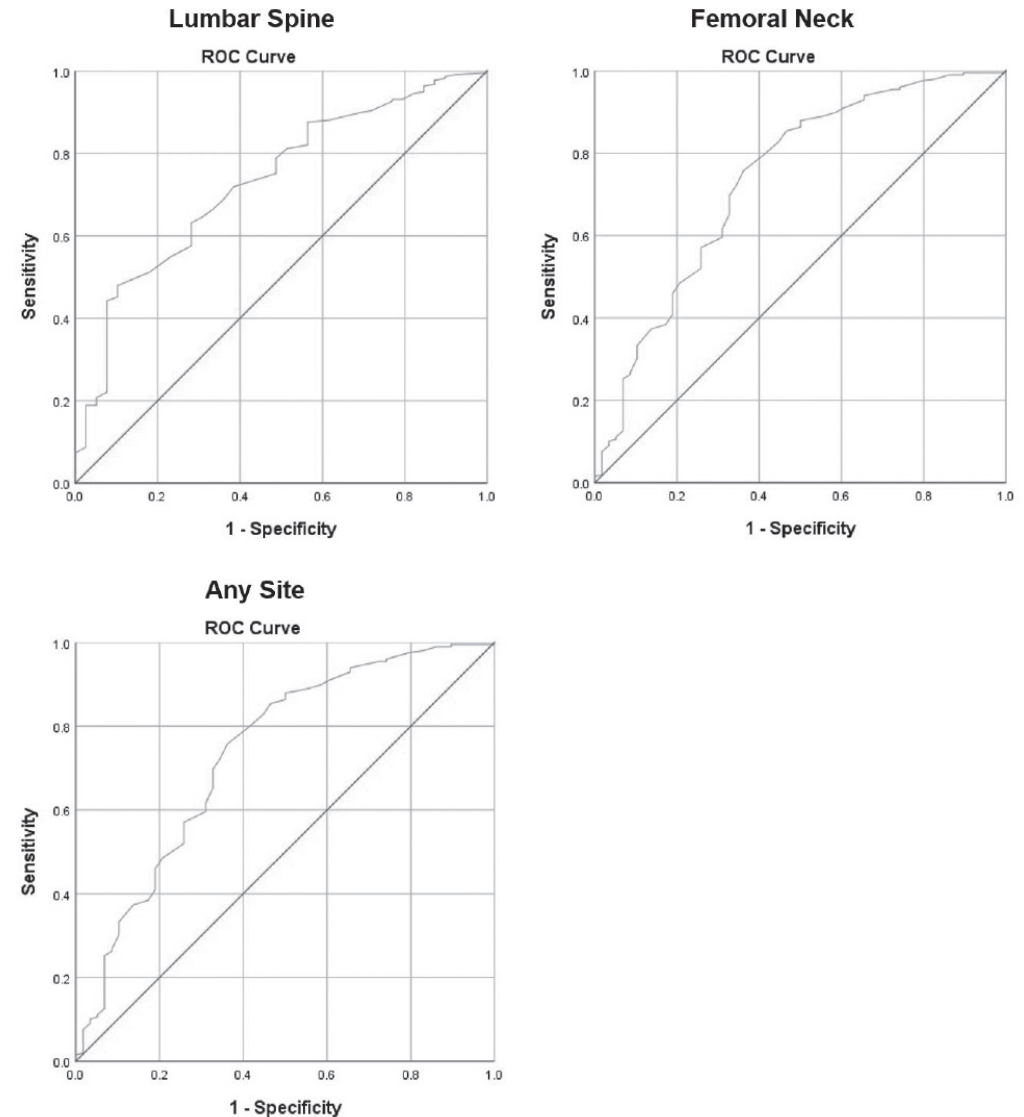

An exploratory first-in-man study to investigate the pharmacokinetics and safety of liposomal dexamethasone at a 2- and 1-week interval in patients with metastatic castration resistant prostate cancer

J.P.M. Vrouwe^{1,2}, I.M.C. Kamerling^{1,3}, M.J. van Esdonk¹, J.M. Metselaar^{4,5}, F.E. Stuurman^{1,6}, G. van der Pluijm⁷, J. Burggraaf^{1,8}, S. Osanto²

Pharmacol Res Perspect. 2021 Oct;9(5):e00845. doi: 10.1002/prp2.845.

1 Centre for Human Drug Research, Leiden, NL

2 Leiden University Medical Centre, Leiden, NL – *Department of Medical Oncology*

3 Leiden University Medical Centre, Leiden, NL – *Department of Infectious diseases*

4 Enceladus Pharmaceuticals, Naarden, NL

5 Rheinisch-Westfälische Technische Hochschule Aachen University clinic, Aachen, D

6 Leiden University Medical Centre, Leiden, NL – *Department of Clinical Pharmacology and Toxicology*

7 Leiden University Medical Centre, Leiden, NL – *Department of Urology*

8 Leiden Academic Centre for Drug Research, Leiden, NL

ABSTRACT

AIM Dexamethasone has antitumour activity in metastatic castration resistant prostate cancer (mCRPC). We aimed to investigate intravenous liposome-encapsulated dexamethasone disodium phosphate (liposomal dexamethasone) administration in mCRPC patients.

METHODS In this exploratory first-in-man study, patients in part A received a starting dose of 10mg followed by 5 doses of 20mg liposomal dexamethasone at two-week intervals. Upon review of part A safety, patients in part B received 10 weekly doses of 18.5mg. Primary outcomes were safety and pharmacokinetic profile, secondary outcome was antitumour efficacy.

RESULTS Nine mCRPC patients (5 in part A, 4 in part B) were enrolled. All patients experienced grade 1-2 toxicity, one (part B) patient experienced grade 3 toxicity (permanent bladder catheter-related urosepsis). No infusion-related adverse events occurred. One patient had upsloping glucose levels ≤ 9.1 mmol/L. Trough plasma concentrations of liposomal- and free dexamethasone were below the lower limit of quantification (LLOQ) in part A, and above LLOQ in 3 patients in part B ($t_{1/2}$ ~50h for liposomal dexamethasone), trough concentrations of liposomal- and free dexamethasone increased towards the end of the study. In seven out of 9 patients (78%) patients, stable disease was observed in bone and/or CT scans at follow-up, and in one (part B) of these 7 patients a >50% PSA biochemical response was observed.

CONCLUSIONS Bi- and once weekly administrations of IV liposomal dexamethasone were well tolerated. Weekly dosing enabled trough concentrations of liposomal- and free dexamethasone >LLOQ. The data presented support further clinical investigation in well-powered studies.

REGISTRATION ISRCTN 10011715

Introduction

Prostate cancer is a highly prevalent disease in the elderly man.¹ Current first-line treatments of primary tumours, i.e. mainly surgery or radiotherapy, are effective in most patients with newly diagnosed apparent organ-confined prostate cancer. However, a considerable proportion of patients may develop incurable metastatic disease. Systemic treatment of advanced prostate cancer usually consists of multiple years of androgen deprivation therapy (ADT) which exerts its antitumour effect via chemical castration, but has a deleterious effect on bone health.²⁻⁴ Once metastasized, bone is affected in ~90% of patients. At this stage, disease progression eventually occurs in almost all prostate cancer patients despite life-long ADT-induced castrate serum testosterone levels (castration-resistant prostate cancer, CRPC).

Corticosteroids have been widely used in the management of CRPC for over 30 years, as a monotherapy (daily orally administered) or combined with abiraterone, docetaxel or cabazitaxel.⁵⁻⁹ In addition to their anti-inflammatory and anti-emetic effects, corticosteroids exhibit antitumour activity in mCRPC. This is attributed to the inhibition of adrenal androgen syntheses, through the CYP17A1, 17 α -hydroxylase pathway.^{10,11} Prednisone or prednisolone are most widely used. However, dexamethasone has a higher ratio of glucocorticoid to mineralocorticoid activity than prednisone, which may result in a better antitumour efficacy in CRPC patients.¹² Patients who switched from abiraterone plus prednisone to abiraterone plus 0.5mg dexamethasone daily, had a biochemical (PSA) response in 11-48% of the cases.¹³⁻¹⁶

Regardless of these advantages, long-term systemic exposure to corticosteroids is associated with serious toxicities such as adrenal insufficiency, immunosuppression, hypertension, oedema, Cushingoid habitus, hyperglycaemia and osteoporosis. Osteoporosis is of particular relevance in CRPC patients who already have numerous risk factors of developing bone health-related problems, including age, multiple osseous metastases and receiving life-long chemical castration through ADT.¹⁷

In general, liposomal delivery can reduce toxicity of the encapsulated drug, as it enables targeted drug delivery to the tumour sites.¹⁸ Liposomes consist of a phospholipid- and cholesterol- bilayer, which can be modified with polyethyleneglycol (PEG). These so-called PEG-liposomes show a prolonged circulating half-life and improved targeting of tumour sites, due to the extravasation through leaky vasculature of solid tumour tissue.¹⁹⁻²¹ The investigational product consists of the disodium phosphate derivate of

dexamethasone, which is encapsulated in the inner aqueous compartment of the PEG-liposomes (liposomal dexamethasone).²⁰ Both the sustained exposure and the targeting facilitated by liposomes are thought to benefit the antitumour efficacy of dexamethasone in liposomal dexamethasone.^{22–25} In a preclinical xenograft model of experimental bone lesions from human prostate cancer, antitumour efficacy of treatment with free dexamethasone and liposomal dexamethasone were compared. A more potent and sustained antitumour effect was indeed found for liposomal dexamethasone.¹⁹

With this new liposomal dexamethasone formulation we envisage IV dosing at a dose level that gives equivalent plasma concentrations of free dexamethasone compared to those expected with the efficacious daily oral dose of 0.5mg dexamethasone, although local tumour exposure is expected to be higher as a result of targeted delivery.^{12,15,26} Anticipating a long circulation half-life, it was decided to evaluate weekly and biweekly IV administrations of liposomal dexamethasone in a population of metastatic CRPC patients (mCRPC). The results of this exploratory first-in-man study with a focus on safety and PK are presented here.

Methods

PATIENTS

Men with documented mCRPC, who had received prior hormonal- and chemotherapy, and for whom no other treatment options were available according to the treating physicians, were eligible. Inclusion criteria (Supplemental Text 1) consisted of the presence of bone metastases, disease progression demonstrated by bone scintigraphy and/or computed tomography (CT) and progressive PSA levels, a castrate serum testosterone level of <50ng/dl or 1.7nmol/L at baseline and patients were not allowed to use systemic corticosteroids within 4 weeks prior to the first study drug administration. Potentially eligible patients from the Clinical Oncology department of the Leiden University Medical Center (LUMC), Leiden, The Netherlands, were referred to the Centre for Human Drug Research (CHDR), Leiden, The Netherlands, for further screening and enrolment. Screening took place after both verbal and written informed consent were obtained, and included collection of baseline characteristics from medical history, physical examination and, routine safety- and disease specific- laboratory assessments.

The study was approved by the medical ethics committee “Foundation Beoordeling Ethiek Biomedisch Onderzoek”, Assen, The Netherlands, and was

conducted in accordance with the Declaration of Helsinki and International Conference on Harmonization/WHO Good Clinical Practice standards. This trial was registered under international standard randomized controlled trials number (ISRCTN) 10011715 and EudraCT number 2016-003121-42.

STUDY DESIGN AND TREATMENT

This was a prospective, single centre, open label, exploratory first-in-man study of two dose regimens of liposomal dexamethasone in patients with mCRPC. The study consisted of parts A and B (Figure 1). In both parts, up to five patients were to be enrolled and were dosed with liposomal dexamethasone for 10 weeks. Treatments consisted of repeated IV administrations of liposomal dexamethasone diluted in 500mL NaCl 0.9% solution right before administration at the hospital pharmacy of the LUMC.

Doses were calculated based on the oral doses of prednisone, prednisolone and dexamethasone administered to mCRPC patients that are reported in literature (Supplemental Table 1).^{5,7,12,15,27–31} The half-life was expected to be prolonged by the liposomes to 30–90h, as observed in clinical studies with other liposomal compounds.^{31,32} Taking into account the PK, the drawback of IV dosing and the vulnerable mCRPC population, dose intervals of one to three weeks were deemed feasible from a pharmacokinetic- and operational perspective. Dose range for weekly- or biweekly liposomal dexamethasone administrations, equivalent to daily oral doses were calculated using molecular weights, (1 µg of dexamethasone disodium phosphate is hydrolysed to of 0.76µg free dexamethasone) and corticosteroid conversion tables from the Dutch national formulary and literature,^{33,34} and ranged from 4.6 to 27.6mg dexamethasone disodium phosphate per 7 days, or from 9.2 to 55.3mg per 14 days.^{5,6}

In part A, patients received a single 10mg dose of liposomal dexamethasone. After one week, a safety review meeting was held to decide if it was safe for the patient to proceed with the five additional doses of 20mg liposomal dexamethasone with two-week intervals. Based on the evaluation of the safety of part A, the dose and administration interval were adapted in part B to ten weekly doses of 18.5mg liposomal dexamethasone. The dose of 18.5mg was chosen as it was deemed appropriate from a PK and safety perspective and to enable dosing the patients from one batch of medication (ampoule contains 18.5mg). In both parts, patients remained in the clinical unit for at least 24 hours after the first and second study drug administrations for safety monitoring and regular PK sampling.

To prevent possible hypersensitivity reactions related to the IV administration of PEG-liposomes, a stepwise increase of the infusion rate (40min 0.05mL/min, 20 min 0.5mL/min, 97min 5mL/min) was applied and a Codan 1.2µm I.V.STAR® filter was used to prevent administration of liposome aggregates. Patients did not receive pre-treatment to prevent infusion reactions.

SAFETY

Patients were evaluated for adverse events during each visit and were asked to report those that had occurred between visits. To quantify potential infusion-related complement activation, the percentage of classic- and alternative pathway complement activation in plasma were measured by levels of membrane attack complex, and factors C1-4, B, H and I before and after the first dose. On pre-defined time points, safety laboratory (fasting blood chemistry, and haematology), vital signs and 12 lead electrocardiography were performed. The full schedule of assessments can be found in Supplemental Table 1. Adverse events (AEs) and serious adverse events (SAE) were registered and graded in accordance with the National Cancer Institute Common Terminology Criteria for AEs (CTCAE).³⁵

PHARMACOKINETIC (PK) ANALYSES

While the liposomes contain dexamethasone disodium phosphate, it is anticipated that after *in vivo* target localization of the liposomes, the contents are released and rapidly hydrolysed to active dexamethasone.³⁴ *Ex vivo*, with part of the liposomes still intact in the circulation, this hydrolysis does not take place, and the free- and liposomal dexamethasone can thus be distinguished by *ex vivo* disruption of the liposomes and analysis of concentrations of both dexamethasone disodium phosphate (LLOQ 0.05 µg/mL) and dexamethasone (LLOQ: 0.005 µg/mL). All PK plasma concentrations were determined using a validated Liquid Chromatography-tandem Mass Spectrometry (LC-MS/MS) bioanalytical method.

Blood samples for PK analysis were obtained at baseline, and 1, 2, 3, 4, 6, 8, 12, 24 and 48 hours after the first two administrations. In part B, PK sampling was expanded with a 96-hour sample and samples right before each of the remaining study drug administrations to measure trough concentrations.

PK data were analysed by non-compartmental analysis in R (V3.6.1), using the PKNCA package.^{36,37} The area under the curve (AUC) was calculated separately for dose 1 and dose 2 using the linear-up log-down method. The AUC_{0-last} and AUC_{0-inf} were calculated to allow for correct comparison of the

exposure to liposomal dexamethasone between weeks. For half-life calculation, the linear regression of the apparent terminal phase was reported if at least 3 points after the maximal concentration (C_{MAX}) were available, with a minimum r^2 of 0.85 and a span ratio of more than 1.5x the half-life.

PHARMACODYNAMICS (PD)

Pharmacodynamic endpoints included plasma concentrations of cortisol and fasting glucose, and lymphocyte counts; these were measured at baseline, after 3, 5, 7 and 9 weeks of treatment, and at the final follow-up visit.

ANTITUMOUR EFFECT

PSA plasma levels were measured at baseline and every four weeks. Plasma levels of haemoglobin, alkaline phosphatase and lactodehydrogenase (LDH) were measured at baseline, after 3, 5, 7 and 10 weeks of treatment, and at the final follow-up visit. Tumours were imaged at baseline and after 12 weeks using bone scintigraphy and/or computed tomography (CT) and evaluated for new lesions and size of existing lesions.

STATISTICS

As this was an exploratory trial with the primary aim of assessing safety and tolerability of liposomal dexamethasone, there was no formal power calculation and outcomes are presented descriptively.

Results

PATIENTS

Ten sequential patients with mCRPC were screened for this study of whom nine were enrolled: five patients in part A, four in part B. One patient was excluded based on limited life expectancy. All patients were enrolled between March 2017 and November 2018. Baseline characteristics are presented in Table 1. The median age of all patients was 70 years. All patients had at least two lines of pharmacological prostate cancer treatment prior to enrolment and no other treatment options were available according to the treating physicians. None of the patients had a diagnosis of diabetes. Eight patients completed all study drug administrations (in part A starting dose of 10mg followed by 5 two-weekly IV doses of 20mg liposomal dexamethasone, and in part B 10 weekly doses of 18.5mg liposomal dexamethasone). In part B, one patient did not receive the last dose. The study was stopped after 9 patients,

as the shelf life of the study drug was not long enough to ensure the tenth patient would receive the full treatment.

SAFETY

Infusion of liposomal dexamethasone was well tolerated and no infusion-related or hypersensitivity reactions were observed. This was confirmed by the absence of changes in the parameters used to assess the classic- or alternative pathway complement activation. A total of 19 treatment emergent AEs were observed in all 9 patients (Table 2), of which 18 were grade 1-2 (12 in part A). One possibly related grade 3 AE, urosepsis, was observed in a patient with an enhanced risk of infection due to a suprapubic bladder catheter and was accompanied by urine abnormalities, hypotension and increased LDH. The patient was admitted to the hospital to receive IV antibiotics, upon which his clinical condition rapidly improved. Due to this admittance, the last dose of liposomal dexamethasone was omitted. A non-related SAE (dyspnoea) was observed in another patient. The most frequently observed AEs (each of which occurred in 2 out of 9 patients (22%)) were infection, restlessness and postural dizziness. Except in relation to the urosepsis, no newly-emergent, clinically significant abnormalities in vital signs, ECG or safety laboratory outcomes, including liver- and renal toxicity- outcomes, occurred. No skeletal-related AEs were observed.

PHARMACOKINETIC RESULTS

A summary of the pharmacokinetics of liposomal dexamethasone and free dexamethasone after the starting dose of 10mg followed by a 20mg dose every two weeks (part A) and the weekly administration of a dose of 18.5mg (part B) is presented in Figure 2 and a tabular overview for liposomal dexamethasone and free dexamethasone is provided in Table 3. The plasma concentration of free dexamethasone was approximately 80-fold lower than that of the liposomal dexamethasone disodium phosphate. Due to the long plasma half-life of liposomal dexamethasone and the timing of the PK sampling, the plasma concentrations in two patients in part A reached insufficient span ratio to enable reliable calculation of AUC_{0-inf} , $t_{1/2}$, and clearance (Figure 2A,B, Table 3). The mean liposomal dexamethasone $t_{1/2}$ in the evaluable patients was 45.73 hours (range: 3.35-69.83). The mean distribution volume (v_z) ranged 2.85 to 4.65L. In higher dose levels, the C_{MAX} was higher too, indicating dose dependency. In part B, trough concentrations (C_{trough}) for liposomal dexamethasone (Figure 2C) and free dexamethasone (Figure

2F) above the lower limit of detection were repeatedly observed in 3 out of 4 patients. C_{trough} for liposomal dexamethasone increased from 0.60 up to 1.26 μ g/mL over 9 weeks of dosing, indicating an accumulation of the liposomes upon subsequent dosing. In one patient (no 6) from part B, the liposomal dexamethasone plasma concentration curve deviates, with a much faster clearance and shorter elimination half-life than the other patients in part A and B.

PHARMACODYNAMIC EFFECTS

Fasting plasma glucose concentrations showed that one part B patient, with an already high baseline plasma glucose concentration (7.4 mmol/L) showed an increase in fasting plasma glucose concentrations up to 9.1mmol/L toward the end of the study. In all other patients, the glucose concentrations remained stable compared to baseline. In part A, plasma cortisol was not suppressed during the dosing period, whereas in group B, cortisol levels were suppressed from the first post-dose measurement onwards, with exception of patient 6 (Supplemental Figure 1).

ANTITUMOUR EFFECTS

Of the nine patients two (22%) patients, one in each part, had a decrease in PSA, of which one patient in part B showed a >50% PSA decrease at the 12-week visit, in one (11%) patient PSA was unchanged, whereas 6 (67%) patients had an increase in PSA (median 90.3%, range: 68.6 to 880%). LDH remained stable compared to baseline, except in two patients, in whom an increase of LDH occurred concurrent with the described SAEs. Haemoglobin was low in three patients from baseline onwards. No significant changes were observed in the alkaline phosphatase concentrations and lymphocyte counts. Radiological evaluation by bone and/or CT scan at 3 months, indicated progressive disease in two patients (one in part A, one in part B), and stable disease in the remaining 7 patients. No additional follow-up scans within the context of this study were done precluding confirmation of radiological responses.

Discussion

We report here the results of an exploratory first-in-man study for safety and PK, in which 9 patients with mCRPC received 10 weeks of IV treatment with an experimental PEG-liposomal formulation of dexamethasone. In this group administration of liposomal dexamethasone was found to be well

tolerated with few grade 1-2 toxicities and similar AEs compared to a study of daily 0.5mg oral dexamethasone in a CRPC patient group.¹² Importantly, no infusion reactions during or immediately after infusion of the liposomes occurred, as was reported in previous studies.^{38,39} For the administration of liposomal dexamethasone we used a stepwise increase of the infusion rate and a filter to prevent administration of liposome aggregates (Figure 1), which may both have contributed to the absence of any infusion related adverse event. Patients did not receive pre-treatment to prevent infusion reactions.

Although the administrations were found to be safe, one possibly treatment-related grade 3 adverse event occurred, which was a urosepsis in a patient at risk of developing urogenital infections due to the presence of a suprapubic catheter. Otherwise, treatment emergent adverse events were mild in severity and most were transient of nature. No bone-related AEs were observed. Fasting glucose remained stable except in the (part B) patient with the highest baseline glucose plasma in whom glucose concentrations increased during the study. This merely underscores the known importance of close monitoring of glucose levels during treatment with corticosteroids.^{17,40}

In part A of the study, the trough level of liposomal- and free dexamethasone prior to the second study drug administration was below the LLOQ in all subjects. As no trough samples were obtained prior to the third- and following doses, accumulation and plasma concentrations above the LLOQ at later time points cannot be ruled out. However, the absence of cortisol suppression during the dosing period seen in this group also suggests that a bi-weekly dosing interval is safe but does not provide the preferred continuous exposure.

Using the dose regimen as in part B of the study, repeated trough concentrations above LLOQ for liposomal- and free dexamethasone, which gradually increased over time, were measured. The PK analysis clearly shows that at multiple time points during treatment liposomal encapsulated as well as free dexamethasone levels above LLOQ and cortisol suppression are achieved after weekly doses of liposomal encapsulated dexamethasone.

Hochhaus et al.⁴¹ have studied the PK after IV administration of 10mg dexamethasone disodium phosphate in young healthy men. The authors report a mean relative AUC in this study of 57 $\mu\text{g}/\text{l}^*\text{h}$ per administered mg of dexamethasone disodium phosphate. We found a similar exposure with the liposomal dexamethasone disodium phosphate formulation, with AUCs in the range of 46.9 to 56.7 $\mu\text{g}/\text{l}^*\text{h}$ for each administered mg. In another study

by Spoorenberg et al.⁴², enrolling patients hospitalized with community acquired pneumonia, a (>2-fold) higher AUC per gram dose was found. This difference is thought to be caused by slower clearance in this specific patient population.⁴²

The liposomal formulation proved effective in prolonging the half-life of dexamethasone, to approximately 2 days (medians of 43-48 hrs), whereas free dexamethasone has a $t_{1/2}$ of 3-5 hours.^{34,41} This half-life is comparable to that of other PEG-liposomal compounds.^{31,32} Due to the length of the $t_{1/2}$ and the PK sampling schedule, a reliable calculation of the $t_{1/2}$ could only be done for three patients of part A. The two other patients appeared to have a longer $t_{1/2}$ but these values cannot be calculated reliably, as the sampling period was too short. Hence, we currently underestimate the $t_{1/2}$ in our outcomes. In part B, a 96h PK sample and trough samples for study drug administrations 2 to 10 were added to the sampling schedule to enable calculation of all PK parameters. The half-life of liposomal dexamethasone varied between subjects, with patient 6 being a clear outlier (Figure 2B, D). In this patient, the half-life was only three hours, which implicates a fast breakdown of the PEGylated liposomes, resulting in a short, high exposure to dexamethasone. Accelerated blood clearance of liposomes has been described after preceding liposome administrations, but in this case fast clearance was already observed following the first administration in this liposome-naïve patient.⁴³ We do not have a mechanistic explanation for this apparent rapid liposomal degradation as we did not find any peculiarities in patient's previous anti-cancer treatments, concomitant medication, laboratory outcomes, leukocyte or monocyte count, or adverse events.

The distribution volume ranged between 2.85 to 4.65L, which is comparable to the plasma volume. The half-life and distribution volume indicate that the majority of liposomal dexamethasone (dexamethasone disodium phosphate) resides in the circulation until organ uptake, subsequent release of the drug from the liposome and hydrolysis to dexamethasone. This process creates a slow release system; explaining the relatively low C_{MAX} and long half-life. Although not measured in this clinical trial, pre-clinical trials support the hypothesis that tumours preferentially take up liposomes and are exposed to relatively high and persisting free dexamethasone concentrations upon release from the liposomes.¹⁹ With this tumour targeting and the relatively low systemic concentrations of free dexamethasone that were observed in this study in mind, one can envisage an enhanced efficacy over safety ratio, which remains to be confirmed in future phase 2 studies.

The absence of cortisol suppression during the dosing period seen in group A patients (although identified after the 3-month treatment period) underscores that a two-week dosing interval of 20mg liposomal dexamethasone is safe. In part B the rapid decline and sustained suppression of endogenous cortisol during the dosing period and demonstrable free dexamethasone concentrations in the blood, is in agreement with the suppression of the cortisol-axis commonly observed during systemic corticosteroid treatment. The PK and PD cortisol axis-suppression data observed following weekly administration of 18.5mg of liposomal-encapsulated dexamethasone in combination with the biochemical PSA and radiological antitumour responses, suggest that a follow-up study using weekly i.v. administrations of liposomal encapsulated dexamethasone is most promising.

This exploratory clinical study focussed on safety and PK, and was not powered, nor set-up to assess antitumour efficacy of liposomal dexamethasone. Hence limitations of the study are the small sample size, and the short period of treatment and follow-up before the biochemical and radiological efficacy evaluations were done. By design, this precludes drawing firm conclusions about the true antitumour efficacy. In one patient, a biochemical response was measured. Although this is a limited effect, this outcome should be seen in the perspective of the study population: end-stage CRPC patients, who had had multiple lines of treatment prior to enrolment.

Future studies with this compound should enrol and evaluate a larger number of patients, in an earlier stage of disease progression, for a longer follow-up period. These studies should explore different dosing regimens, starting at weekly 18.5mg doses, or slightly lower, based on the current study. In addition, methods to investigate the delicate balance between optimal delivery of the liposomal encapsulated drug at the site of metastases and systemic release of free drug methods should be integrated. The use of PET fluorescence- or radio-labelled liposomal dexamethasone could confirm whether liposomal encapsulated dexamethasone indeed (preferentially) targets the tumour sites as has been observed in our animal model.¹⁹ With preliminary safety shown in a vulnerable patient population, these efficacy and target localization studies are now warranted.

In conclusion, IV administration of liposomal dexamethasone was well tolerated in this small group of mCRPC patients. The safety- and pharmacokinetic profile of weekly IV administered liposomal dexamethasone support further trials to investigate the targeting and efficacy of liposomal dexamethasone in well-powered experiments, and the possibility of combination with other anticancer agents.

REFERENCES

- Siegel RL, Miller KD, Jemal A. Cancer statistics, 2020. *CA Cancer J Clin.* 2020;70(1):7-30. doi:10.3322/caac.21590
- Bubendorf L, Schopfer A, Wagner U, et al. Metastatic patterns of prostate cancer: an autopsy study of 1,589 patients. *Hum Pathol.* 2000;31(5):578-583. doi:10.1053/hp.2000.6698
- Mohamad N v, Soelaiman IN, Chin KY. A Review on the Effects of Androgen Deprivation Therapy (ADT) on Bone Health Status in Men with Prostate Cancer. *Endocr Metab Immune Disord Drug Targets.* 2017;17(4):276-284. doi:10.2174/1871530317666170919112757
- el Badri SAM, Salawu A, Brown JE. Bone Health in Men with Prostate Cancer: Review Article. *Curr Osteoporos Rep.* 2019;17(6):527-537. doi:10.1007/s11914-019-00536-8
- Fossa SD, Slee PH, Brausi M, et al. Flutamide versus prednisone in patients with prostate cancer symptomatically progressing after androgen-ablative therapy: a phase III study of the European organization for research and treatment of cancer genitourinary group. *J Clin Oncol.* 2001;19(1):62-71. doi:10.1200/JCO.2001.19.1.62
- Tannock I, Gospodarowicz M, Meakin W, Panzarella T, Stewart L, Rider W. Treatment of metastatic prostatic cancer with low-dose prednisone: evaluation of pain and quality of life as pragmatic indices of response. *J Clin Oncol.* 1989;7(5):590-597. doi:10.1200/JCO.1989.7.5.590
- Venkitaraman R, Thomas K, Huddart RA, Horwich A, Dearnaley DP, Parker CC. Efficacy of low-dose dexamethasone in castration-refractory prostate cancer. *BJU Int.* 2008;101(4):440-443. doi:10.1111/j.1464-410X.2007.07261.x
- Teo MY, Rathkopf DE, Kantoff P. Treatment of Advanced Prostate Cancer. *Annu Rev Med.* 2019;70:479-499. doi:10.1146/annurev-med-051517-011947
- Shamash J, Powles T, Sarker S, et al. A multi-centre randomised phase III trial of Dexamethasone vs Dexamethasone and diethylstilbestrol in castration-resistant prostate cancer: immediate vs deferred Diethylstilbestrol. *British journal of cancer.* 2011;104(4):620-628. doi:10.1038/BJC.2011.7
- Eichholz A, Ferraldeschi R, Attard G, de Bono JS. Putting the brakes on continued androgen receptor signaling in castration-resistant prostate cancer. *Mol Cell Endocrinol.* 2012;360(1-2):68-75. doi:10.1016/j.mce.2011.09.038
- Khandwala HM, Vassilopoulou-Sellin R, Logethesis CJ, Friend KE. Corticosteroid-induced inhibition of adrenal androgen production in selected patients with prostate cancer. *Endocr Pract.* 2001;7(1):11-15. doi:10.4158/ep.7.1.11
- Venkitaraman R, Lorente D, Murthy V, et al. A randomised phase 2 trial of dexamethasone versus prednisolone in castration-resistant prostate cancer. *Eur Urol.* 2015;67(4):673-679. doi:10.1016/j.eururo.2014.10.004
- Fenioux C, Louvet C, Charton E, et al. Switch from abiraterone plus prednisone to abiraterone plus dexamethasone at asymptomatic PSA progression in patients with metastatic castration-resistant prostate cancer. *BJU Int.* 2019;123(2):300-306. doi:10.1111/bju.14511
- Lorente D, Ormlin A, Ferraldeschi R, et al. Tumour responses following a steroid switch from prednisone to dexamethasone in castration-resistant prostate cancer patients progressing on abiraterone. *Br J Cancer.* 2014;111(12):2248-2253. doi:10.1038/bjc.2014.531
- Romero-Laorden N, Lozano R, Jayaram A, et al. Phase II pilot study of the prednisone to dexamethasone switch in metastatic castration-resistant prostate cancer (mCRPC) patients with limited progression on abiraterone plus prednisone (SWITCH study). *Br J Cancer.* 2018;119(9):1052-1059. doi:10.1038/s41416-018-0123-9
- Roviello G, Petrioli R, Bonetta A, Conca R, Rodriquenz MG, Aieta M. Corticosteroid switch in heavily pretreated castration-resistant prostate cancer patients progressed on abiraterone acetate plus prednisone. *Invest New Drugs.* 2018;36(6):1110-1115. doi:10.1007/s10637-018-0685-7
- Rice JB, White AG, Scarpati LM, Wan G, Nelson WW. Long-term Systemic Corticosteroid Exposure: A Systematic Literature Review. *Clin Ther.* 2017;39(11):2216-2229. doi:10.1016/j.clinthera.2017.09.011
- Matsumura Y, Maeda H. A new concept for macromolecular therapeutics in cancer chemotherapy: mechanism of tumortropic accumulation of proteins and the antitumor agent smancs. *Cancer Res.* 1986;46(12 Pt 1):6387-6392.
- Kroon J, Buijs JT, van der Horst G, et al. Liposomal delivery of dexamethasone attenuates prostate cancer bone metastatic tumor growth in vivo. *Prostate.* 2015;75(8):815-824. doi:10.1002/pros.22963
- Fenske DB, Chonn A, Cullis PR. Liposomal nanomedicines: an emerging field. *Toxicol Pathol.* 2008;36(1):21-29. doi:10.1177/0192623307310960
- Abu Lila AS, Ishida T. Liposomal Delivery Systems: Design Optimization and Current Applications. *Biol Pharm Bull.* 2017;40(1):1-10. doi:10.1248/bpb.116-00624
- MI K, S K, I F, et al. High intratumoural accumulation of stealth liposomal doxorubicin (Caelyx) in glioblastomas and in metastatic brain tumours. *British journal of cancer.* 2000;83(10):1281-1286. doi:10.1054/BJOC.2000.1459
- Batist G, Sawyer M, Gabrail N, et al. A multicenter, phase II study of CPX-1 liposome injection in patients (pts) with advanced colorectal cancer (CRC). *Journal of Clinical Oncology.*

2008;26(15_suppl):4108-4108. doi:10.1200/JCO.2008.26.15_SUPPL.4108

24 Clark A, Wiley D, Zuckerman J, et al. CRLX101 nanoparticles localize in human tumors and not in adjacent, nonneoplastic tissue after intravenous dosing. *Proceedings of the National Academy of Sciences of the United States of America*. 2016;113(14):3850-3854. doi:10.1073/PNAS.1603018113

25 Miller MA, Zheng Y, Gadde S, et al. Tumour-associated macrophages act as a slow-release reservoir of nano-therapeutic Pt(IV) pro-drug. *NATURE COMMUNICATIONS*. 2015;6. DOI:10.1038/NCOMMS9692

26 ElBayoumi T, Torchilin V. Tumor-targeted nanomedicines: enhanced antitumor efficacy in vivo of doxorubicin-loaded, long-circulating liposomes modified with cancer-specific monoclonal antibody. *Clinical cancer research: an official journal of the American Association for Cancer Research*. 2009;15(6):1973-1980. doi:10.1158/1078-0432.CCR-08-2392

27 Morioka M, Kobayashi T, Furukawa Y, et al. Prostate-specific antigen levels and prognosis in patients with hormone-refractory prostate cancer treated with low-dose dexamethasone. *Urologia Internationalis*. 2002;68(1):10-15. doi:10.1159/000048411

28 Nishimura K, Nonomura N, Yasunaga Y, et al. Low doses of oral dexamethasone for hormone-refractory prostate carcinoma. *Cancer*. 2000;89(12):2570-2576. doi:10.1002/1097-0142(20001215)89:12<2570::aid-cnrc9>3.0.co;2-h

29 Storie JA, Buckner JC, Wiseman GA, Burch PA, Hartmann LC, Richardson RL. Prostate specific antigen levels and clinical response to low dose dexamethasone for hormone-refractory metastatic prostate carcinoma. *Cancer*. 1995;76(1):96-100. doi:10.1002/1097-0142(19950701)76:1<96::AID-CNCR2820760114>3.0.CO;2-E

30 Tannock IF, de Wit R, Berry WR, et al. Docetaxel plus prednisone or mitoxantrone plus prednisone for advanced prostate cancer. *New England Journal of Medicine*. 2004;351(15):1502-1512. doi:10.1056/NEJMoa040720

31 Amantea M, Forrest A, Northfelt D, Mamelok R. Population pharmacokinetics and pharmacodynamics of PEGylated-liposomal doxorubicin in patients with AIDS-related Kaposi's sarcoma. *Clinical pharmacology and therapeutics*. 1997;61(3):301-311. doi:10.1016/S0009-9236(97)90162-4

32 Gabizon A, Shmeeda H, Barenholz Y. Pharmacokinetics of PEGylated liposomal Doxorubicin: review of animal and human studies. *Clinical pharmacokinetics*. 2003;42(5):419-436. doi:10.2165/00003088-200342050-00002

33 Mager DE, Lin SX, Blum RA, Lates CD, Jusko WJ. Dose equivalency evaluation of major corticosteroids: pharmacokinetics and cell trafficking and cortisol dynamics. *J Clin Pharmacol*. 2003;43(11):1216-1227. doi:10.1177/0091270003258651

34 Zorginstituut Nederland. Systemic corticosteroids. *Farmacotherapeutisch Kompas*. consulted. https://www.farmacotherapeutischkompas.nl/bladeren/groepsteksten/corticosteroiden_systemisch

35 NIH. Common Terminology Criteria for Adverse Events (CTCAE) version 5.0. Published online 2017:1-147.

36 Team RC. R: A language and environment for statistical computing. *R Foundation for Statistical Computing, Vienna, Australia*. Published online 2019. <https://www.r-project.org/>

37 Denney W, Buckeridge C DS. Simple, Automatic Noncompartmental Analysis: The PKNCA R Package. *Journal of Pharmacokinetics and Pharmacodynamics*. 2015;42(1):11-107. <https://github.com/billdenney/PKNCA>

38 Szebeni J. Complement activation-related pseudoallergy: a stress reaction in blood triggered by nanomedicines and biologicals. *Mol Immunol*. 2014;61(2):163-173. doi:10.1016/j.molimm.2014.06.038

39 Szebeni J, Simberg D, González-Fernández Á, Barenholz Y, Dobrovol'skaia MA. Roadmap and strategy for overcoming infusion reactions to nanomedicines. *Nat Nanotechnol*. 2018;13(12):1100-1108. doi:10.1038/s41565-018-0273-1

40 Rowbottom L, Stinson J, McDonald R, et al. Retrospective review of the incidence of monitoring blood glucose levels in patients receiving corticosteroids with systemic anticancer therapy. *Ann Palliat Med*. 2015;4(2):70-77. doi:10.3978/j.issn.2224-5820.2015.04.07

41 Hochhaus G, Barth J, al-Fayoumi S, et al. Pharmacokinetics and pharmacodynamics of dexamethasone sodium-m-sulfobenzoate (DS) after intravenous and intramuscular administration: a comparison with dexamethasone phosphate (DP). *J Clin Pharmacol*. 2001;41(4):425-434. doi:10.1177/00912700122010285

42 Spoorenberg S, Deneer V, Grutters J, et al. Pharmacokinetics of oral vs. intravenous dexamethasone in patients hospitalized with community-acquired pneumonia. *British journal of clinical pharmacology*. 2014;78(1):78-83. doi:10.1111/BCP.12295

43 Ishida T, Harada M, Wang XY, Ichihara M, Irimura K, Kiwada H. Accelerated blood clearance of PEGylated liposomes following preceding liposome injection: effects of lipid dose and PEG surface-density and chain length of the first-dose liposomes. *J Control Release*. 2005;105(3):305-317. doi:10.1016/j.jconrel.2005.04.003

Table 1 Baseline patient and disease characteristics

Patient characteristics	Total group N=9	Part A N=5	Part B N=4
AGE (YEARS)			
At enrolment, median (range)	70 (61-77)	67 (61-74)	73 (70-77)
At disease onset, median (range)	65 (52-75)	61 (52-67)	68 (65-75)
WEIGHT (KG)			
median (range)	93.5 (74.8-118.4)	101.4 (93.5-118.4)	90.0 (74.8-93.5)
HEIGHT (CM)			
median (range)	178.2 (169-193)	180.3 (178.2-193.2)	175.4 (169.0-176.0)
BMI (KG/M²)			
median (range)	29.9 (24.0-36.4)	31.2 (27.1-36.4)	29.3 (24.0-32.7)
BASELINE BLOOD PLASMA CONCENTRATIONS			
Haemoglobin, mmol/L median (range)	7.0 (5.8-9.8)	7 (5.8-9.8)	6.7 (5.8-8.0)
Alkaline phosphatase, U/L median (range)	152 (58-313)	152 (110-261)	147 (58-313)
Lactate dehydrogenase, U/L median (range)	200 (169-425)	180 (169-220)	257 (181-425)
TIME EXPIRED (MONTHS)			
Initial diagnosis to enrolment, median (range)	62 (28-113)	85 (42-113)	37 (32-104)
CRPC to enrolment, median (range)	22 (10-49)	22 (14-49)	22 (10-35)
ECOG PERFORMANCE SCORE			
0, N (%)	1 (11)	0 (0)	1 (25)
1, N (%)	6 (67)	4 (80)	2 (50)
2, N (%)	2 (22)	1 (20)	1 (25)
PSA (ug/L)			
Baseline median (range)	17.1 (4.4-424.4)	72.9 (9.2-213.6)	160.3 (4.4-424.4)
PSA BEFORE FIRST HORMONE THERAPY (ug/L)			
Median (range)	27.3 (9.2->1100)	23 (9.2-186)	56 (12.8->1100)
PREVIOUS LINES OF TREATMENT			
LHRH agonist/previous ADT (+/- bicalutamide), N (%)	9 (100)	5 (100)	4 (100)
Enzalutamide, N (%)	8 (89)	4 (80)	4 (100)
Abiraterone + prednisone, N (%)	1 (11)	1 (20)	0 (0)
Docetaxel + prednisone, N (%)	6 (67)	3 (60)	3 (75)
Cabazitaxel + prednisone, N (%)	3 (33)	1 (20)	2 (50)
Radium-223 (%)	3 (33)	2 (40)	1 (25)

BMI, body mass index. ECOG, eastern cooperative oncology group. PSA prostate specific antigen LHRH, luteinizing hormone releasing hormone. ADT, androgen deprivation therapy

Table 2 Treatment emergent adverse events graded according the National Cancer Institute Common terminology criteria for Adverse events (CTCAE) version 5.0.

Adverse event	Part A (1 × 10mg + 5 × 20mg)		Part B (10 × 18.5mg)	
	Grade 1-2 N (%)	Grade 3-4 N (%)	Grade 1-2 N (%)	Grade 3-4 N (%)
Any adverse event	5 (100)	0 (0)	4 (100)	1 (25)
All infections	0 (0)	0 (0)	1 (25)	1 (25)
Postural dizziness	1 (20)	0 (0)	1 (25)	0 (0)
Fatigue	2 (40)	0 (0)	0 (0)	0 (0)
Restlessness	1 (20)	0 (0)	1 (25)	0 (0)
Hypertension	0 (0)	0 (0)	1 (25)	0 (0)
Oedema	0 (0)	0 (0)	1 (25)	0 (0)
Cancer related pain	1 (20)	0 (0)	0 (0)	0 (0)
Hot flashes	1 (20)	0 (0)		
Skin atrophy	1 (20)	0 (0)	0 (0)	0 (0)
Presyncope	1 (20)	0 (0)	0 (0)	0 (0)
Proteinuria	1 (20)	0 (0)	0 (0)	0 (0)
Urine incontinence	1 (20)	0 (0)	0 (0)	0 (0)
Dysgeusia	1 (20)	0 (0)	0 (0)	0 (0)
Hyperglycaemia	0 (0)	0 (0)	1 (25)	0 (0)
Confused state	0 (0)	0 (0)	1 (25)	0 (0)
Infusion reaction	0 (0)	0 (0)	0 (0)	0 (0)
Influenza like illness	0 (0)	0 (0)	0 (0)	0 (0)
Pyrexia	0 (0)	0 (0)	0 (0)	0 (0)
Nausea/vomiting	0 (0)	0 (0)	0 (0)	0 (0)
Hypotension	0 (0)	0 (0)	0 (0)	0 (0)
Anaemia	0 (0)	0 (0)	0 (0)	0 (0)
Leukopenia	0 (0)	0 (0)	0 (0)	0 (0)
(febrile) Neutropenia	0 (0)	0 (0)	0 (0)	0 (0)
Thrombocytopenia	0 (0)	0 (0)	0 (0)	0 (0)
ASAT increase	0 (0)	0 (0)	0 (0)	0 (0)
ALAT increase	0 (0)	0 (0)	0 (0)	0 (0)
Bilirubinaemia	0 (0)	0 (0)	0 (0)	0 (0)
Asthenia	0 (0)	0 (0)	0 (0)	0 (0)

ASAT aspartate aminotransferase, ALAT alanine aminotransferase

Table 3 Summary of PK parameters for A. liposomal dexamethasone and B. free dexamethasone.

A. Liposomal dexamethasone (dexamethasone disodium phosphate)				
Dose 1	Part A	Part B		
	PK 10mg	PK 18.5mg		PK 18.5mg
	Mean (SD)	range	Mean (SD)	range
C _{MAX} (µg/mL)	2.392 (0.520)	1.70-2.99	4.45 (1.07)	2.93-5.22
T _{MAX} (h)	3.0 ^a	3.0-3.0	3.0 ^a	3.0-3.0
AUC _{INF} (h*µg/mL)	209.5 (57.4) ^b	149-263 ^b	354.5 (259.4)	19.3-600
AUC _{LAST} (h*µg/mL)	142 (71.1)	60.2-234	297 (203)	19-483
CL (L/h)	0.050 (0.015) ^b	0.038-0.067 ^b	0.27 (0.46)	0.031-0.96
VZ (L)	3.34 (0.43)	2.85-3.66	3.6 (0.72)	3.11-4.65
T _{1/2} (h)	47.7 (10.0) ^b	36.22-54.8 ^b	43.4 (31.0)	3.35-69.8
Dose 2	PK 20mg	PK 18.5mg		
	Mean (SD)	range	Mean (SD)	range
C _{MAX} (µg/mL)	5.02 (0.96)	3.65-6.36	4.99 (2.21)	1.98-6.84
T _{MAX} (h)	4.0 ^a	3.0-4.0	3.5	3.0-6.0
AUC _{LAST} (h*µg/mL)	179 (47.1)	124-246	347 (257)	4.34-573
T _{1/2} (h)	- ^c	- ^c	54.0 (15.2)	44.5-71.6 ^b
B. Free dexamethasone (dexamethasone)				
Dose 1	Part A	Part B		
	PK 10mg	PK 18.5mg		PK 18.5mg
	Mean (SD)	range	Mean (SD)	range
C _{MAX} (µg/mL)	0.023 (0.012)	0.012-0.041	0.032 (0.021)	0.013-0.053
T _{MAX} (h)	8.0 ^a	4.0-12.0	8.0 ^a	6.0-23.2
AUC _{LAST} (h*µg/mL)	0.421 (0.305)	0.091-0.904	0.660 (0.610)	0.188-1.56
Dose 2	PK 20mg	PK 18.5mg		
	Mean (SD)	range	Mean (SD)	range
C _{MAX} (µg/mL)	0.062 (0.033)	0.032-0.112	0.047 (0.032)	0.016-0.080
T _{MAX} (h)	11.0 ^a	8.0-12.0	8.5 ^a	6.0-12.0
AUC _{LAST} (h*µg/mL)	1.61 (0.942)	0.83-3.09	1.8 (1.18)	0.70-3.47

^a Median

^b Value based on measurements in three patients

^c T_{1/2} could not be calculated as trough samples were not obtained prior to dose 3

Figure 1 Study design and set-up for study drug administration Study design and set-up for study drug administration. After evaluation of the PK and PD results.

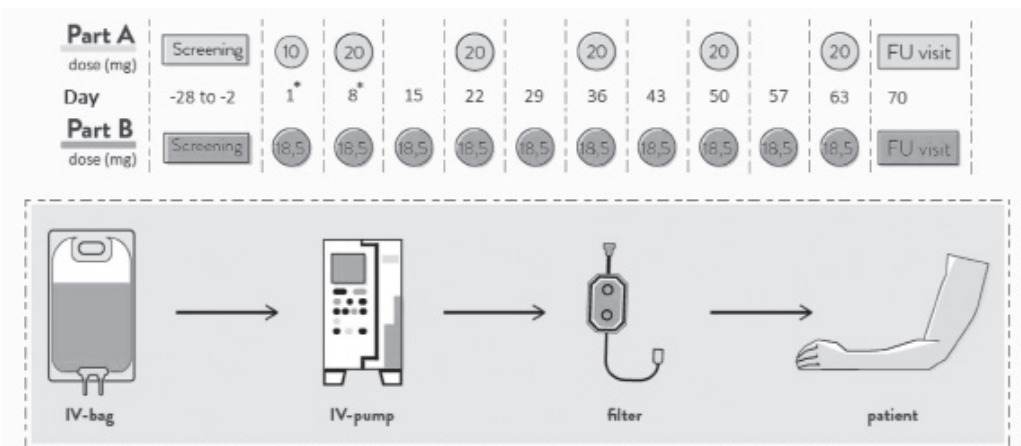

* After the drug administrations of weeks 1 and 2, patients stayed overnight in the clinic for safety monitoring and PK sampling

Figure 2 PK panel liposomal dexamethasone (dexamethasone disodium phosphate) and free dexamethasone (dexamethasone) PK of liposomal dexamethasone disodium phosphate (liposomal dexamethasone) and free dexamethasone for groups A (panels A and D) and B (panels B and E), after the first administration (up to day 7) and second administration (from day 7 onwards). For part B, PK sampling was adjusted by adding samples on days 4, 11 and prior to the remaining study drug administrations, enabling a more complete PK profile and plots of the trough concentrations (panels C and F). Trough concentrations were above the LLOQ and ascending trends of the trough concentrations were measured toward the end of the study in all patients except nr. 6. In patient 6, a rapid clearance of liposomal- and free dexamethasone is observed, seen as a rapid decrease of the liposomal dexamethasone concentration (panels B and E). The plasma molarity of the inactive liposomal dexamethasone disodium phosphate was approximately 80-fold higher than that of the free (active) dexamethasone.

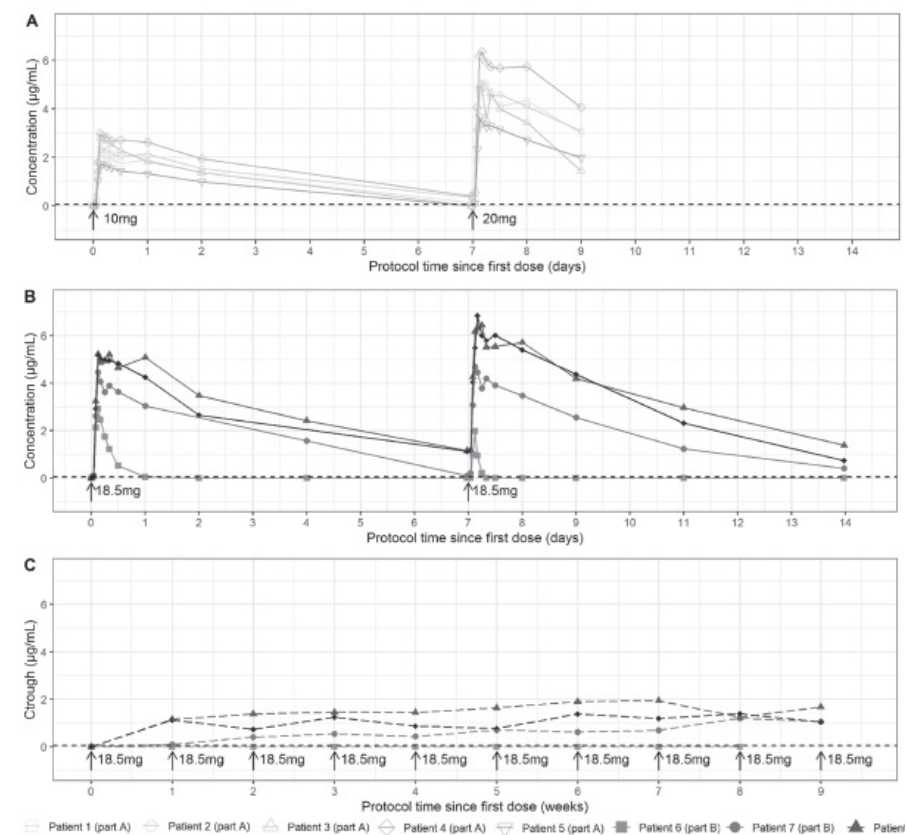

(Continuation Figure 2)

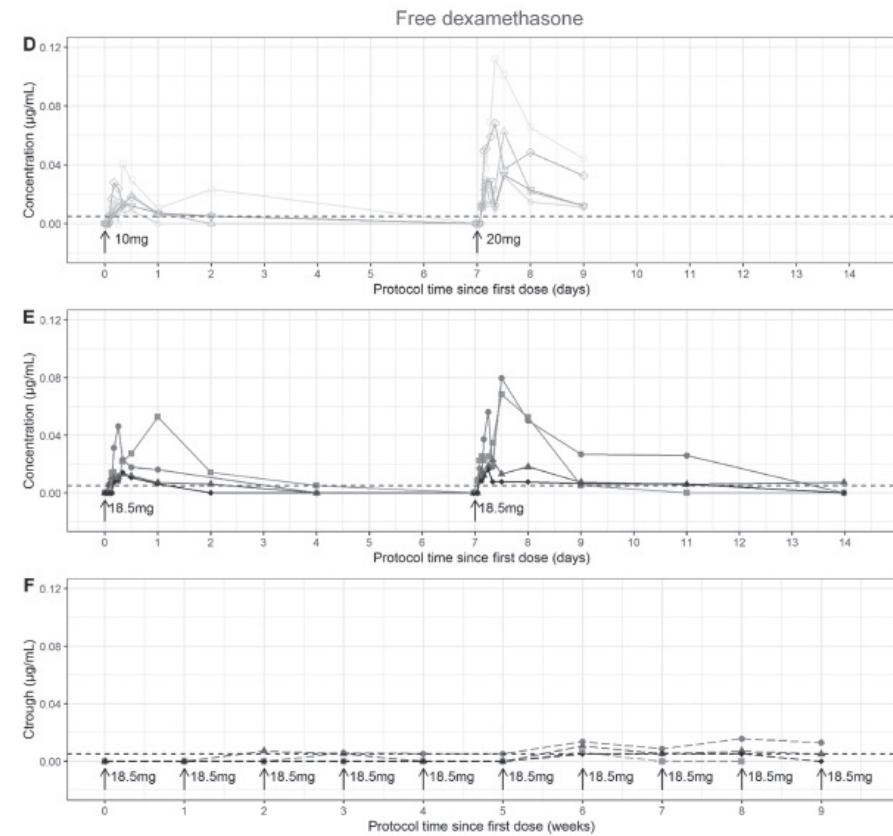

18 (part B) ◆ Patient 9 (part B)

SECTION II

OSTEOARTHRITIS THERAPIES

CHAPTER 5

Challenges and opportunities of pharmacological interventions for osteoarthritis: a review of clinical trials and current developments

J.P.M. Vrouwe¹, J. Burggraaf^{1,2}, M. Kloppenburg^{3,4}, F.E. Stuurman^{1,5}

Osteoarthritis and Cartilage Open. 2021. 3(4), doi:10.1016/j.ocarto.2021.100212

-
- 1 Centre for Human Drug Research, Leiden, NL
 - 2 Leiden Academic Center for Drug Research, Leiden, NL
 - 3 Leiden University Medical Center, Leiden, NL - *Department of Rheumatology*
 - 4 Leiden University Medical Center, Leiden, NL - *Department of Epidemiology*
 - 5 Leiden University Medical Center, Leiden, NL - *Department of Toxicology*
-

ABSTRACT

OBJECTIVE Osteoarthritis (OA) is the most common cause of disability in older adults and leads to a huge unmet medical need as no registered disease modifying OA drugs (DMOADs), but only symptomatic treatments are available. New pharmacological targets, and compounds for these targets, are currently under investigation. The objective of this paper is to provide an overview of compounds under investigation for OA in phase II and III.

DESIGN We performed a review of OA trials for pharmacological interventions registered on the National Library of Medicine ClinicalTrials.gov website with a completion date in 2017 or later.

RESULTS The database search yielded 255 results, of which 184 studies were included in this review. These were structured in compounds targeting pain, immunomodulators, stem cell therapy, platelet rich plasma and DMOADs with cartilage and/or bone resorption modifying properties.

CONCLUSIONS The results provide an overview of the fields in development and may include future treatment options for OA, by which a registered DMOADs may become more than a utopic vista. Further knowledge on pathophysiology and new approaches of value-based drug development could be an opportunity for the optimization of drug development in OA.

Introduction

Clinically, osteoarthritis (OA) manifests as joint pain and/or joint dysfunction.¹ Its pathophysiology is multifactorial and depends on metabolic, genetic, and biomechanical factors.² The (severity of) symptoms of OA depends on the phase of the disease, and varies between patients.³⁻⁵ Symptoms of OA and the absence of an effective disease modifying treatment contribute to patients' functional impairment and sense of illness.^{3,6} The incidence of OA increases with age.^{3,7} Altogether, OA is the most common cause of severe long-term pain and disability in older adults, causing loss of work productivity and significant healthcare- and social support costs. Given the personal burden, the illness may result in a negative effect on mental health and may seriously impact the quality of life of patients and their relatives.⁷⁻⁹

Multiple joint tissues are involved; cartilage was long thought to play the primary role, as it lacks regenerative properties. But although cartilage is usually damaged, it is an aneural tissue and pain only appears once innervated tissues are involved.¹⁰ Synovium and subchondral bone are also recognized to be involved in the disease process from an early stage on.¹⁰⁻¹²

In the last decade, studies to these aspects in pathophysiology have uncovered several different mediators that are associated with joint degeneration and OA related pain. These insights unveiled new targets for the development of disease-modifying OA drugs (DMOADs). The objective of this paper is to provide a background of OA treatments and its restrictions, upon which the pipeline of pharmacological interventions in OA is reviewed, using the clinicaltrials.gov database to get a representative, up-to-date, overview of the pharmacological interventions that are currently under investigation.

CURRENT TREATMENTS

Several organizations have brought out guidelines for treatment of OA,¹³⁻¹⁶ thorough reviews of which are published elsewhere.^{17,18} Current treatments for OA are restricted to symptom relief. In short, various non-pharmacological and pharmacological interventions are available, all with modest effects. Therefore, a combination of therapeutic approaches is commonly used, the choice of which is based on individual factors such as affected joint(s), disease extensiveness, and severity, in addition to the presence of concurrent signs and symptoms.^{13-16,19}

Non-pharmacological interventions consist of exercise, weight loss, education, and self-management programs, which are recommended for all

types of OA.^{14,19} Among pharmacological interventions are: oral and topical non-steroidal anti-inflammatory drugs (NSAIDS), paracetamol, tramadol, duloxetine, chondroitin, intra-articular steroid administration, and topical capsaicin.¹⁴ The advised order of steps in the treatment of OA varies between guidelines and patients.^{13–15,19}

LIMITATIONS OF CURRENT TREATMENTS

The available pharmacological interventions do not have a meaningful disease modifying effect. As a result, the condition worsens over time and in some cases leads to arthroplasty. Although the cost of total hip- or knee replacement in the USA are estimated to be \$22,000 to \$30,000, their cost-effectiveness is well established.²⁰ Unfortunately, arthroplasties are commonly preceded by a long trajectory of pain and functional limitation and unsuccessful in some patients, with complications during the post-surgical trajectory.²¹

The availability of DMOADS would lead to improvement of quality of life and a vast reduction of health care costs.²² So far, several attempts of developing DMOADS have failed, among which are sprifermin, bisphosphonates and matrix metalloproteinase (MMP)-inhibitors.^{23–25} Reasons for failure include wrong assumptions in animal to human translation, side effects, structural symptom discordance, incorrect structural endpoints and a substantial placebo effect for OA related pain.^{23,24,26}

Further knowledge on the pathophysiological processes in OA is imperative to enable appropriate pharmacological targeting, as the key factors that drive progressive joint destruction and pain are still only partly understood. The pain experienced by patients seems to be a combination of inflammatory (nociceptive) and/or neuropathic-like pain, and there are multiple local structures which cause pain and evolves during the progression of OA.^{3,5} As a result, personalized treatment plans, considering the phase and mechanism causing symptoms, are preferable.²⁷ However, currently there are no well-established biomarkers to enable such profiling for clinical studies. Researchers also struggle to define and measure a valid set of endpoints.

Methods

A structured search in the clinicaltrials.gov database was performed in November 2020. For the condition or disease “Osteoarthritis” was chosen and all phase II and phase III interventional trials with a completion date in 2017 or later were selected.

Trials with pharmacotherapeutic interventions in OA patients, were included. Studies which did not aim to investigate intention to treat OA, or which aimed to investigate effects of arthroplasty, shock wave therapy or Chinese medicine therapy, were excluded. Two authors (RS and JV) reviewed all search results for inclusion independently; outcomes were compared, and disagreements were resolved by discussion.

For each trial, details of the compound (assumed mechanism of action and target cells/receptors) and trial details (target joint, randomization, blinding, inclusion of a placebo) were collected. All results were then described per category based on intended mechanism of action.

Results

The database search yielded 255 results, of which 184 studies were included in this review. Seventy-one trials were excluded based on the exclusion criteria.

Most studies included patients with knee OA (160 studies), others investigated outcomes in hip-(23 studies) shoulder-(8 studies), hand-(5 studies) or lumbar spine (1 study) OA. Six studies did not define the affected joint. Other data collected for each study were the phase of study execution and study design.

From the database search, it becomes apparent that the pipeline includes several reformulations, or combinations of existing treatment options such as NSAIDS (10 results), corticosteroids (11 results) and hyaluronic acid (10 results). In addition, new insights have already led to the identification of new treatment targets, which includes pain pathways (Table 1), DMOADS that aim to interfere with inflammation (Table 2), interventions which involve mesenchymal stromal cells (MSC) or platelet-rich plasma (PRP) (Table 3) and target cartilage- or viscosupplementation (Table 4).

PAIN MODULATION

The generation and modification of chronic pain takes place at different levels along the neuraxis.²⁸ The nociceptive cell bodies are in the dorsal root ganglia and can be activated and sensitized by inflammation.^{29,30} Dorsal root ganglia neurons express several receptors that can be selectively targeted, including G-protein coupled receptors (GPCRs) and ion channels.³¹ Compounds that interfere with GPCRs include opioid, cannabinoid, muscarinic, acetylcholine and somatostatin receptors, which are already pharmaceutically targeted for countless analgesic indications.

Placebo controlled trials for selective- and non-selective opioid receptor binding compounds Difelikefalin (NCT02944448) and Naltrexon (NCT03008590), showed a high incidence of adverse events, without improvement of OA symptoms in the active groups. A study for a combination of tramadol and celecoxib, YXC301, is to start (NCT03850587). Cannabinoids are also under investigation; pre-clinically, cannabidiol (CBD) is a promising analgesic,³² but a study for the effects of a dermal application of cannabinoid oil was negative.³³ Several other studies for CBD and tetrahydrocannabinol (THC) in knee- and hand-OA, are ongoing (Table 1).

Current studies for compounds with affinity for ion channels, include those targeting the transient receptor potential vanilloid 1 (TRPV1), such as (trans-)capsaicin. Topical capsaicin was shown effective in knee OA but is not recommended for hip- and hand OA due to the depth of the joint, and the risk of contaminating the eyes.¹⁴ CNTX-4975, is a highly purified, synthetic trans-capsaicin, with an analgesic effect via reversible deactivation of end terminals of primary afferent pain fibers within the joint. In a phase II study, it reduced pain and improved physical function in OA patients, up to at least 24 weeks after intra-articular administration.³⁴ However, (possibly dose related) procedural pain was higher than in the placebo group.³⁴ Still, three phase III studies with this compound are recruiting patients with knee OA (NCT03661996, NCT03429049, NCT03660943). Several other TRPV1 antagonists are studied, with results pending (NCT03528369, NCT02558439, NCT03028870). NEO6860 is a promising compound, as it showed analgesic effects in knee OA, without adverse events observed in other TRPV1 antagonists, but due to an earlier completion date, it did not come up in our search.³⁵

A monoclonal antibody which is also currently studied in a phase II study, targets transforming growth factor alpha and epiregulin (LY306859, NCT04456686), which inhibits inflammatory pathways to reduce pain.

Several other mechanisms of pain modulation are explored for OA. Botulinum toxin A, effective at the neuromuscular junction, is investigated in three ongoing studies in knee- and hand-OA.³⁶ Two studies investigate optimal doses of non-selective serotonin reuptake inhibitor Duloxetine (NCT04224584, NCT04504812). In earlier trials, Duloxetine was (positively) evaluated for its efficacy in OA pain, and guidelines already recommend the use of Duloxetine.^{14,16}

The development of pan-Trk inhibitors GZ389988 and ONO-4474 and TrkA receptor antagonists ASP7962 and VM902A and the Artemin-receptor targeting REGN5069 (NCT03956550) was stopped for corporate strategy reasons.³⁷

Anti-nerve growth factor antibodies

Nerve growth factor (NGF) is a member of the neurotrophin family of molecules which binds to neurotrophic tyrosine kinase receptor type 1 (tropomyosin-related kinase A, TrkA).³⁸ NGF is essential for the development of sympathetic- and sensory neurons, the last are responsible for nociception and temperature sensation. A systematic review concluded that reduction in pain and the improvement in function in OA may be a class effect of NGF antibodies.³⁹

Anti-NGF tanezumab showed a reduction in joint pain and functional impairment.⁴⁰ After a long trajectory of (pre-)clinical development, with two FDA-mandated temporary holds because of rapidly progressive OA (RPOA), and sympathetic nerve system AES, respectively.⁴¹ A request for approval with the FDA was submitted, but in a vote in March 2021, the FDA decided against approval for OA, because of the observation of RPOA.^{40,42} Another anti-NGF monoclonal antibody, Fanisumab, had promising results in a phase II clinical trial in OA patients, but this entire class of anti-NGFs may run into the issue of RPOA.⁴³ Phase III trials in knee- and hip OA are currently ongoing (Table 1).

IMMUNOMODULATION

Inflammation in OA is mostly apparent as low-grade, chronic inflammation, primarily mediated by the innate immune system.⁴⁴ Synovitis, apparent as low-grade inflammatory infiltrates, is associated with severity of symptoms, cartilage degeneration, osteophyte formation and joint dysfunction and present from an early stage of OA.^{10,44,45}

Tumor necrosis factor alpha (TNF- α), interleukin (IL)-1 α , IL-1 β , IL-6, IL-15, IL-17, and IL-18 are considered the major mediators involved in the pathophysiology of OA.⁴⁶⁻⁴⁸ Although their exact roles in the pathogenesis of OA is still under investigation, their antibodies are already evaluated in clinical trials (Table 2). Previous studies with several compounds targeting IL-1 (AMG 108, Anakinra and Litikizumab), did not benefit patients with hand- or knee OA.⁴⁹⁻⁵²

TNF- α blockers are highly efficacious in rheumatoid arthritis and TNF- α could also have a significant role in the pathogenesis of OA, since TNF- α expression is increased in the joint tissues.⁴⁶ However, results of hand OA-trials showed no beneficial effects on pain of TNF- α blockers adalimumab and etanercept.^{53,54}

Otilimab (GSK3196165) is a fully human monoclonal antibody for granulocyte macrophage-colony stimulating factor (GM-CSF), which inhibits

macrophage proliferation, an important element in development of OA-related pain and joint swelling.⁵⁵ A 12-week study showed that treatment of patients with inflammatory hand OA was well tolerated and reduced pain (NCT02683785), but no ongoing clinical trials in OA are registered.⁵⁶

Interleukin-6 is an inflammatory cytokine which plays a role in the upregulation of matrix metalloproteinases 3 and 13,⁵⁷ but anti-IL-6 monoclonal antibody Tocilizumab did not improve outcomes in hand OA (NCT02477059).⁵⁸

XT-150 is an IL-10 expressing plasmid DNA gene therapy product for which a study in knee OA is currently ongoing (NCT04124042). No publications on pre-clinical studies were found.

The low-molecular-weight fraction of 5% human serum albumin (LMWF-5A) contains aspartyl-alanyl diketopiperazine (DA-DKP), which inhibits the release of TNF- α in synoviocytes.⁵⁹ In a post hoc pooled analysis of three randomized placebo (saline) controlled trials in patients with severe knee OA, LMWF-5A showed a significant decrease in pain at 12 weeks, improvements in function, and patient global assessment.⁶⁰ The long-term effects of LMWF-5A are currently investigated in an open label phase III extension study (NCT03988023).

Curcumin and ginger are polyphenols with presumed anti-inflammatory properties through cyclo-oxygenase (COX)2, prostaglandin, and leukotoxin inhibition, and are used as alternative therapies in osteoarthritis.⁶¹ As with other supplements, daily doses vary widely, and robust evidence of its efficacy is lacking. Ongoing trials for the effects of Curcumin and Resveratrol, another polyphenol, were found (NCT02905799, NCT03715140).⁶²

The development of p53 inhibitor UBX0101 was stopped, as the 12-week objective (reduction of pain) in the phase II trial (NCT04129944) was not met.⁶³ The development of inflammatory pathway inhibitor Piclidenoson (NCT00837291) was terminated for corporate reasons.

MULTIPOTENT MESENCHYMAL STROMAL CELLS

Multiple clinical trials with MSC were initiated during the last decade. MSC are stromal cells that can differentiate into a variety of connective tissue lineages, including bone-forming osteoblasts and cartilage-forming chondrocytes.⁶⁴ MSC can be isolated from a variety of tissues, such as placenta, umbilical cord, bone marrow, and adipose tissue. In the joints MSC contribute to the maintenance of healthy cartilage and the response to injury. Amongst other tissues, they reside in the diarthrodial joints, where they act as a reservoir for other cells.⁶⁵ MSC also have paracrine and immunomodulatory

effects, reducing local inflammation through inhibition of T-cell and B-cell proliferation, when exposed to certain cytokines like TNF- α and IL-1.⁶⁶ The MSC of patients with end-stage OA have substantially reduced proliferative and chondrogenic capacity, which may contribute to OA progression.^{65,67} As such, MSC may have the potential to halt inflammation and regeneration of tissues.⁶⁵

The regenerative properties of MSC intends to work through intra-articular injection of MSC after *ex-vivo* culture-expanding preparation. In a goat-model of post-traumatic OA, this was successfully tested: a meniscal repair response and clinical improvement of the treated joints, as well as paracrine effects, were confirmed.⁶⁸

We found 51 interventional clinical trials with MSC-based therapy in OA, the majority of which investigate knee OA (Table 3). The source of these cells is variable and includes bone marrow-derived, adipose tissue-derived, and umbilical cord/placenta/Wharton's jelly derived MSC. Most of these studies are RCTs (65%), but only 45% are blinded, and (24%) are placebo controlled.

The effects of previous MSC-based therapies for knee OA were investigated in reviews and meta-analyses of randomized controlled clinical trials.^{61,69,70} Some studies showed a dose-response relationship and short term improvement in pain and function, but there was little to no evidence for DMOAD activity.^{61,69,70} In literature, the potential of MSC-based therapy for OA is recognized, but origin and preparation lack standardization.^{14,61,64} In order to draw firm conclusions about the efficacy of MSC, and to recommend MSC-based therapies in guidelines, well-described, standardized preparation methods must still be conducted.

Despite the current lack of proven efficacy, minimally manipulated adipose tissue injections are widely available at clinics.⁷¹

PLATELET-RICH PLASMA

PRP contains an elevated concentration of platelets, growth factors, cytokines, adhesive proteins and plasma proteins and leucocytes.⁷² These constitutes, influence the innate immune response in many ways. The growth factors, also mediate the proliferation and differentiation of MSC, which could contribute to cartilage repair.⁷³ In a meta-analysis of 74 RCTs, symptomatic outcome effects of PRP in knee OA were compared with those of hyaluronic acid and corticosteroids. Most included studies (87%) were blinded and showed superior outcomes of PRP injections compared to hyaluronic acid and corticosteroids; this positive effect on WOMAC score and VAS faded

after one year follow-up.⁷⁴ These outcomes may be affected by publication bias and the designs of the included studies (randomized, blinded) is not representative for the studies registered in *clintrials.gov* (Table 3). Finally, few studies for the efficacy of PRP treatment of OA in other joints have been performed, precluding conclusions on its efficacy.^{75,76}

Our search yielded 15 studies investigating platelet-rich plasma in knee- (11 studies), hip- (2 studies), and shoulder- (1 study) OA. Similarities are observed between the study designs of these studies and those investigating MSC: 80% of the studies are randomized, 40% are blinded and 20% are placebo controlled. A review for PRP preparation techniques and its relation to patient reported outcomes also found wide variations.⁷⁷ Clearly this field is upcoming, but the applied preparation, dose, and dose interval vary widely, precluding conclusions on effectiveness. Consequently, the efficacy of PRP in OA is yet to be confirmed in high-quality, long-term follow-up studies.^{73,75,76}

CARTILAGE METABOLISM AND BONE RESORPTION

Table 4 captures pharmacological interventions which aim to restore or maintain cartilage and the subchondral bone.

The progressive destruction of cartilage in OA involves degradation of its matrix constituents (collagen and aggrecan) by matrix metalloproteinases (MMPs) and/or proteinases 'A Disintegrin and Metalloproteinases with Thrombospondin' (ADAMTS) motifs 4 and 5, in combination with the failure to repair the tissue.^{78,79} Blocking ADAMTS and MMPs, may inhibit the degradation of collagen and aggrecan degradation and preserve cartilage.

Inhibitors for MMP have been evaluated as OA treatments, but their efficacy was poor and local safety profile unfavorable, possibly due to lack of specificity.^{78,80} Indeed, no results for MMP inhibitors were found (Table 4).

Two completed studies for ADAMTS-5 inhibitors in knee OA were found: anti-ADAMTS-5 nanobody M6495 (NCT03583346) and ADAMTS-5 inhibitor GLPG1972 (NCT03595618). In a phase I trial in healthy volunteers, GLPG1972 was well tolerated and prevented the release of aggrecan fragments, which can be a signal of joint protection.^{81,82} However, the compound failed to reduce cartilage loss in the phase II efficacy study.⁸³

Cathepsin K is a lysosomal cysteine protease, expressed in osteoclasts and chondrocytes, which also cleaves aggrecan and collagen.⁷⁸ MIV-711 is a cathepsin-K inhibitor that showed structure modifying properties in pre-clinical models and reduced crosslinks levels pre-clinically and in healthy volunteers.⁸⁴ A phase II trial showed that MIV-711 significantly reduced

progression of bone and cartilage loss, with a tolerable safety profile, but it did affect pain.⁸⁵

TPX-100 and LRX712 target chondroprogenitor cells, which aim for regeneration and repair of cartilage by inducing chondroprogenitor cell differentiation and production of new extracellular matrix. A placebo-controlled phase II study for TPX-100, showed that treatment was safe and improved knee function, with reduction in pain and disease burden, but no follow up study is registered.⁸⁶

In the joint, the Wnt pathway helps to control tissue homeostasis through regulation of MSC differentiation into chondrocytes and osteoblasts. Increased Wnt signaling stimulates production of pro-inflammatory cytokines and catabolic enzymes like MMP.⁸⁷ Wnt pathway inhibitor, Lorecivint (SMO4690) preclinically showed potential to improve symptoms of knee OA.⁸⁸ Inflammatory cytokines and cartilage degradative enzymes were inhibited, resulting in increased cartilage and functionality and decreased pain.⁸⁸ In a phase II study, a single administration with Lorecivint, did not yet lead to statistically significant improvement of knee OA pain, physical function, or improved medial joint space width compared to placebo.⁸⁹ Other phase II and III studies in knee OA are currently ongoing.

Several studies for Invossa™ (TissueGeneC) are ongoing; it consists of chondrocytes which are retrovirally transduced to overexpress transforming growth factor-β1. In a double-blind, placebo-controlled phase III trial in patients with knee OA, Invossa™ was found safe and improved pain and patient reported functional outcomes compared to a placebo group. No significant change was observed in cartilage thickness.⁹⁰

As the condition of the subchondral bone contributes to OA progression, it may be a target for pharmacological interventions.¹¹ A randomized, placebo controlled trial with zoledronic acid in knee OA patients with bone marrow lesions, improved pain and bone marrow lesion size after one year.⁹¹ However, efficacy of bisphosphonates was not confirmed in a study with two-year follow-up.²⁵ In a meta-analysis for the efficacy of bisphosphonates on improvement of pain and radiological progression, an effect failed to materialize too.⁹² Nevertheless, two studies are currently recruiting knee- and hip OA patients (NCT043030, NCT02746068). Studies for calcium-regulating compounds Denosumab and Teriparatide in knee- and hand OA, are currently ongoing (NCT02771860, NCT03072147).

Viscosupplementation intends to lubricate the joint and relief pain by doing so. Studies investigating viscosupplements are either new formula-

tions of hyaluronic acid alone, or a combination of hyaluronic acid and corticosteroids/NSAIDs. Ongoing studies investigate compounds with the dual aim of viscosupplementation and cartilage repair (SB-061, collagen-PVP, and MM-II), but no (pre-)clinical results of these compounds were found published.

Finally, glucosamine and chondroitin sulphate are popular food supplements which intend to treat pain and loss of function in OA. Several systematic reviews and meta-analyses have analyzed their efficacy, with various outcomes. Some find a positive effect on pain and/or function,⁹³ whereas others are inconclusive or do not find a positive effect on function compared to placebo.⁹⁴ New formulations of glucosamine (NCT02830919), and combination with NSAIDs (NCT03936192) are under investigation.

Discussion

The understanding of mechanisms that lead to chronic pain in OA has evolved. As a result, therapies for OA pain are transforming from classic analgesics towards more mechanism-based interventions on different levels, such as pain modulation, inflammation, and cartilage regeneration. These new insights may be beneficial for patient- and societal burden.²²

In this paper, the pipeline of treatments in development for OA was reviewed. We used the clinicaltrials.gov database to get a representative, up-to-date, overview of the pharmacological interventions under investigation. The use of the clinical trial registry gives up-to-date outcomes and to some extent prevents publication bias, in contrast to a search of published data. The international committee of medical journal editors requires prospective clinical trial registration with the aim of transparency,⁹⁵ but it remains unknown which studies are not registered or registered elsewhere.⁹⁶ Clinicaltrials.gov is a well-recognized clinical trial registry, which leads to representative search results.

A potential limitation of this search strategy is that we chose not to include phase I and phase IV trials in our results. This may have led to missing potential new candidates that are in a very early stage of clinical development (phase I), and studies with registered compounds, for new indications. Although both categories potentially yield new treatments for OA. We aimed to create an overview of new candidate compounds for OA, which have passed the first phase of development, hence phase I and phase IV trials were not in the scope of this paper.

Information from 184 studies for pharmacological interventions for osteoarthritis was collected, giving a good impression of the study designs in the field. In the categories of pain, immunomodulation and cartilage metabolism, high percentages of blinded, randomized, placebo-controlled trials were found (Tables 1, 2 and 4). This was less so for studies investigating the effects of MSC and platelet rich plasma. A blinded, randomized, placebo-controlled trial is generally assessed to be the most valuable study design for interventional studies.⁹⁷ Therefore, study designs are an opportunity in the fields of MSC and platelet rich plasma. Those studies would enable drawing firmer conclusions on MSC and PRP efficacy.

Overall, success is still elusive. One of the great challenges is the translation of preclinical animal models to the patient situation.⁹⁸ Many compounds with promising results in preclinical and early clinical studies, fail in phase I or II clinical trials. This might be explained by the fact that OA is such a complex heterogeneous disease in which multiple pathways lead to pain and functional failure of joints. Although research on the mechanisms involved is active at this moment and continually provides new insights and therapeutic targets to treat OA, it seems that important outcome parameters may be absent or missed in pre-clinical and early phase clinical drug development.

Applied interventions and primary outcomes of trials with patients who have different underlying pathophysiology, or different phases of disease progression, must be different.²⁷ The pathophysiological processes, contribution of sensitization of nociceptive pathways and psychosocial factors vary depending on the origin and stage of the disease. Currently, there is insufficient information about these phenotypes, to enable adequate patient selection efficient translation from pre- and early clinical drugs to a successfully registered DMOAD.

Rational starting points to optimize early development, would be to focus on the pathophysiology of early-stage OA in preclinical and clinical experiments. The feasibility of trials in phenotypically well-characterized patient populations, using validated (wet-, digital-, or imaging-) biomarkers, is currently under investigation.⁹⁹ Furthermore, follow-up during the progression of OA requires more accurate and adequate endpoints examples of which are structural (quantitative) imaging and information gained from wearables.¹⁰⁰

Conclusion

High-quality research for compounds with potential disease modifying activity is ongoing. Meanwhile, a more complete understanding of the development of OA and a set of clinically valid and responsive biomarkers are thought essential players in the success of (clinical studies for) pharmacological interventions in OA.

REFERENCES

1. Virginia Byers Kraus, Francisco J. Blanco, Martin Englund, Morten A. Karsdal and L.S.L. Stratification for Clinical Trials and Clinical Use. *Osteoarthritis and Cartilage*. 2016;23(8):1233-1241. doi:10.1016/j.joca.2015.03.036.Call
2. Haseeb A, Haqqi TM. Immunopathogenesis of osteoarthritis. *Clinical Immunology*. 2013;146(3):185-196. doi:10.1016/j.clim.2012.12.011
3. Neogi T. The epidemiology and impact of pain in osteoarthritis. *Osteoarthritis Cartilage*. 2013;21(9):1145-1153. doi:10.1016/j.joca.2013.03.018
4. Hunter DJ, Guermazi A, Roemer F, Zhang Y, Neogi T. Structural correlates of pain in joints with osteoarthritis. *Osteoarthritis Cartilage*. 2013;21(9):1170-1178. doi:10.1016/j.joca.2013.05.017
5. Hochman JR, French MR, Birmingham SL, Hawker GA. The nerve of osteoarthritis pain. *Arthritis Care Res (Hoboken)*. 2010;62(7):1019-1023. doi:10.1002/acr.20142
6. Thomas E, Peat G, Mallen C, et al. Predicting the course of functional limitation among older adults with knee pain: do local signs, symptoms and radiographs add anything to general indicators? *Ann Rheum Dis*. 2008;67(10):1390-1398. doi:10.1136/ard.2007.080945
7. WHO | Chronic rheumatic conditions. WHO. Published online 2016.
8. Kaplan W, Wirtz VJ, Mantel-Teeuwisse A, Stok P, Duthey B, Laing R. Priority medicines for Europe and the world 2013 update. WHO. Published online 2013. doi:10.1017/CBO9781107415324.004
9. Vergés Milano J, Herrero Barbero M, Giménez Basallote S, et al. Anxiety and depression in knee osteoarthritic patients: Results from EMARTRO study. *Osteoarthritis Cartilage*. 2016;24:S218-S219. doi:https://doi.org/10.1016/j.joca.2016.01.422
10. Sellam J, Berenbaum F. The role of synovitis in pathophysiology and clinical symptoms of osteoarthritis. *Nat Rev Rheumatol*. 2010;6(11):625-635. doi:10.1038/nrrheum.2010.159
11. Burr DB, Gallant MA. Bone remodelling in osteoarthritis. *Nature Reviews Rheumatology*. 2012;8(11):665-673. doi:10.1038/nrrheum.2012.130
12. Saberi Hosnijeh F, Bierma-Zeinstra SM, Bay-Jensen A-C. Osteoarthritis year in review 2018: biomarkers (biochemical markers). *Osteoarthritis and Cartilage*. 2019;27(3):412-423. doi:10.1016/j.joca.2018.12.002
13. Bruyère O, Honvo G, Veronese N, et al. An updated algorithm recommendation for the management of knee osteoarthritis from the European Society for Clinical and Economic Aspects of Osteoporosis, Osteoarthritis and Musculoskeletal Diseases (ESCEO). *Seminars in Arthritis and Rheumatism*. 2019;49(3):337-350. doi:10.1016/j.semarthrit.2019.04.008
14. Kolasinski SL, Neogi T, Hochberg MC, et al. 2019 American College of Rheumatology/Arthritis Foundation Guideline for the Management of Osteoarthritis of the Hand, Hip, and Knee. *Arthritis Rheumatol*. 2020;72(2):220-233. doi:10.1002/art.41142
15. Kloppenburg M, Kroon FPB, Blanco FJ, et al. 2018 update of the EULAR recommendations for the management of hand osteoarthritis. *Annals of the Rheumatic Diseases*. 2019;78(1):16-24. doi:10.1136/annrheumdis-2018-213826
16. Bannuru RR, Osani MC, Vaysbrot EE, et al. OARS1 guidelines for the non-surgical management of knee, hip, and polyarticular osteoarthritis. *Osteoarthritis and Cartilage*. 2019;27(11):1578-1589. doi:10.1016/j.joca.2019.06.011
17. Katz JN, Arant KR, Loeser RF. Diagnosis and Treatment of Hip and Knee Osteoarthritis: A Review. *Jama*. 2021;325(6):568-578. doi:10.1001/jama.2020.22171
18. Arden NK, Perry TA, Bannuru RR, et al. Non-surgical management of knee osteoarthritis: comparison of ESCEO and OARS1 2019 guidelines. *Nature Reviews Rheumatology*. 2021;17(1):59-66. doi:10.1038/s41584-020-00523-9
19. Fernandes L, Hagen KB, Bijlsma JWJ, et al. EULAR recommendations for the non-pharmacological core management of hip and knee osteoarthritis. *Annals of the Rheumatic Diseases*. 2013;72(7):1125-1135. doi:10.1136/annrheumdis-2012-202745
20. Kamaruzaman H, Kinghorn P, Oppong R. Cost-effectiveness of surgical interventions for the management of osteoarthritis: a systematic review of the literature. *BMC Musculoskeletal Disorders*. 2017;18(1). doi:10.1186/s12891-017-1540-2
21. Wylde V, Hewlett S, Learmonth ID, Dieppe P. Persistent pain after joint replacement: prevalence, sensory qualities, and postoperative determinants. *Pain*. 2011;152(3):566-572. doi:10.1016/j.pain.2010.11.023
22. Losina E, Daigle ME, Suter LG, et al. Disease-modifying drugs for knee osteoarthritis: can they be cost-effective? *Osteoarthritis Cartilage*. 2013;21(5):655-667. doi:10.1016/j.joca.2013.01.016
23. Wang K, Xu J, Hunter DJ, Ding C. Investigational drugs for the treatment of osteoarthritis. *Expert Opinion on Investigational Drugs*. 2015;24(12):1539-1556. doi:10.1517/13543784.2015.1091880
24. Hochberg MC, Guermazi A, Guehring H, et al. Effect of Intra-Articular Sprifermin vs Placebo on Femorotibial Joint Cartilage Thickness in Patients with Osteoarthritis: The FORWARD Randomized Clinical Trial. *JAMA - Journal of the American Medical Association*. 2019;322(14):1360-1370. doi:10.1001/jama.2019.14735
25. Bingham CO, Buckland-Wright JC, Garner P, et al. Risedronate decreases biochemical markers of cartilage degradation but does not decrease

- symptoms or slow radiographic progression in patients with medial compartment osteoarthritis of the knee: Results of the two-year multinational knee osteoarthritis structural arthritis study. *Arthritis and Rheumatism*. 2006;54(11):3494-3507. doi:10.1002/art.22160
26. Zhang W, Robertson J, Jones AC, Dieppe PA, Doherty M. The placebo effect and its determinants in osteoarthritis: Meta-analysis of randomised controlled trials. *Annals of the Rheumatic Diseases*. 2008;67(12):1716-1723. doi:10.1136/ard.2008.092015
27. Bowden JL, Hunter DJ, Deveza LA, et al. Core and adjunctive interventions for osteoarthritis: efficacy and models for implementation. *Nature Reviews Rheumatology*. 2020;16(8):434-447. doi:10.1038/s41584-020-0447-8
28. Eitner A, Hofmann GO, Schaible HG. Mechanisms of Osteoarthritic Pain. Studies in Humans and Experimental Models. *Front Mol Neurosci*. 2017;10:349. doi:10.3389/fnmol.2017.00349
29. Ellis A, Bennett DL. Neuroinflammation and the generation of neuropathic pain. *Br J Anaesth*. 2013;111(1):26-37. doi:10.1093/bja/aet128
30. Raouf R, Willemsen H, Eijkelkamp N. Divergent roles of immune cells and their mediators in pain. *Rheumatology (Oxford)*. 2018;57(3):429-440. doi:10.1093/rheumatology/kex308
31. Malfait AM, Miller RJ. Emerging Targets for the Management of Osteoarthritis Pain. *Curr Osteoporos Rep*. 2016;14(6):260-268. doi:10.1007/s11914-016-0326-z
32. Philpott H, O'Brien M, McDougall J. Attenuation of early phase inflammation by cannabidiol prevents pain and nerve damage in rat osteoarthritis. *Pain*. 2017;158(12):2442-2451. doi:10.1097/J.PAIN.0000000000001052
33. Hunter D, Oldfield G, Tich N, Messenheimer J, Sebree T. Synthetic transdermal cannabidiol for the treatment of knee pain due to osteoarthritis. *Osteoarthritis Cartilage*. 2018;26:S26. doi:10.1016/j.joca.2018.02.067
34. Stevens RM, Ervin J, Nezzar J, et al. Randomized, Double-Blind, Placebo-Controlled Trial of Intraarticular Trans-Capsaicin for Pain Associated With Osteoarthritis of the Knee. *Arthritis and Rheumatology*. 2019;71(9):1524-1533. doi:10.1002/art.40894
35. Arsenault P, Chiche D, Brown W, et al. NEO6860, modality-selective TRPV1 antagonist: A randomized, controlled, proof-of-concept trial in patients with osteoarthritis knee pain. *Pain Reports*. 2018;3(6). doi:10.1097/PR9.0000000000000696
36. Abrams SB, Hallett M. Clinical utility of different botulinum neurotoxin preparations. *Toxicon*. 2013;67:81-86. doi:10.1016/j.toxicon.2012.11.024
37. Bailey JJ, Jaworski C, Tung D, Wängler C, Wängler B, Schirmacher R. Tropomyosin receptor kinase inhibitors: an updated patent review for 2016-2019. *Expert Opinion on Therapeutic Patents*. 2020;30(5):325-339. doi:10.1080/13543776.2020.1737011
38. Wood JN. Nerve Growth Factor and Pain. *New England Journal of Medicine*. 2010;363(16):1572-1573. doi:10.1056/NEJME1004416
39. Jayabalan P, Schnitzer TJ. Tanezumab in the treatment of chronic musculoskeletal conditions. *Expert Opinion on Biological Therapy*. 2017;7(2):245-254. doi:10.1080/14712598.2017.1271873
40. Berenbaum F, Blanco FJ, Guermazi A, et al. Subcutaneous tanezumab for osteoarthritis of the hip or knee: Efficacy and safety results from a 24-week randomised phase III study with a 24-week follow-up period. *Annals of the Rheumatic Diseases*. 2020;79(6):800-810. doi:10.1136/annrheumdis-2019-216296
41. Hochberg MC, Tive LA, Abramson SB, et al. When Is Osteonecrosis Not Osteonecrosis?: Adjudication of Reported Serious Adverse Joint Events in the Tanezumab Clinical Development Program. *Arthritis and Rheumatology*. 2016;68(2):382-391. doi:10.1002/art.39492
42. Joint FDA Advisory Committee Votes on Application for Tanezumab for the Treatment of Osteoarthritis Pain | pfizer.com. Accessed June 8, 2021. <https://www.pfizer.com/news/press-release/press-release-detail/joint-fda-advisory-committee-votes-application-tanezumab>
43. Dakin P, DiMartino SJ, Gao H, et al. The Efficacy, Tolerability, and Joint Safety of Fasinumab in Osteoarthritis Pain: A Phase IIB/III Double-Blind, Placebo-Controlled, Randomized Clinical Trial. *Arthritis and Rheumatology*. 2019;71(11):1824-1834. doi:10.1002/art.41012
44. Robinson WH, Lepus CM, Wang Q, et al. Low-grade inflammation as a key mediator of the pathogenesis of osteoarthritis. *Nature Reviews Rheumatology*. 2016;12(10):580-592. doi:10.1038/nrrheum.2016.136
45. Goldring MB, Otero M. Inflammation in osteoarthritis. *Current Opinion in Rheumatology*. 2011;23(5):471-478. doi:10.1097/BOR.0b013e328349c2b1
46. Kapoor M, Martel-Pelletier J, Lajeunesse D, Pelletier JP, Fahmi H. Role of proinflammatory cytokines in the pathophysiology of osteoarthritis. *Nature Reviews Rheumatology*. 2011;7(1):33-42. doi:10.1038/nrrheum.2010.196
47. Wojdasiewicz P, Poniatowski ŁA, Szukiewicz D. The role of inflammatory and anti-inflammatory cytokines in the pathogenesis of osteoarthritis. *Mediators of Inflammation*. 2014;2014. doi:10.1155/2014/561459
48. Dias CNK, Vasilceac FA, Durigan JLO, Medeiros AI de, Mattiello SM. Analysis of local and systemic TNF- α and IL1- α expression in the acute phase of knee osteoarthritis of rats. *Cytokine*. 2014;66(2):164-165. doi:10.1016/j.cyto.2014.01.006
49. Chevalier X, Goupille P, Beaulieu AD, et al. Intraarticular injection of anakinra in osteoarthritis of the knee: A multicenter, randomized, double-blind, placebo-controlled study. *Arthritis Care and Research*. 2009;61(3):344-352. doi:10.1002/art.24096
50. Cohen SB, Proudman S, Kivitz AJ, et al. A randomized, double-blind study of AMG 108 (a fully human monoclonal antibody to IL-1R1) in patients with osteoarthritis of the knee. *Arthritis Research and Therapy*. 2011;13(4). doi:10.1186/ar3430
51. Kloppenburg M, Peterfy C, Haugen IK, et al. Phase IIA, placebo-controlled, randomised study of lutikizumab, an anti-interleukin-1 α and anti-interleukin-1 β dual variable domain immunoglobulin, in patients with erosive hand osteoarthritis. *Annals of the Rheumatic Diseases*. 2019;78(3):413-420. doi:10.1136/annrheumdis-2018-213336
52. Fleischmann RM, Bliddal H, Blanco FJ, et al. A Phase II Trial of Lutikizumab, an Anti-Interleukin-1 α / β Dual Variable Domain Immunoglobulin, in Knee Osteoarthritis Patients With Synovitis. *Arthritis and Rheumatology*. 2019;71(7):1056-1069. doi:10.1002/art.40840
53. Aitken D, Laslett LL, Pan F, et al. A randomised double-blind placebo-controlled crossover trial of HUMira (adalimumab) for erosive hand Osteoarthritis - the HUMOR trial. *Osteoarthritis and Cartilage*. 2018;26(7):880-887. doi:10.1016/j.joca.2018.02.899
54. Kloppenburg M, Ramonda R, Bobacz K, et al. Etanercept in patients with inflammatory hand osteoarthritis (EHOA): A multicentre, randomised, double-blind, placebo-controlled trial. *Annals of the Rheumatic Diseases*. 2018;77(12):1757-1764. doi:10.1136/annrheumdis-2018-213202
55. Cook AD, Pobjoy J, Steidl S, et al. Granulocyte-macrophage colony-stimulating factor is a key mediator in experimental osteoarthritis pain and disease development. *Arthritis Research and Therapy*. 2012;14(5). doi:10.1186/ar4037
56. Schett, Bainbridge, Berkowitz, Davy. A Phase IIA Study of Anti-GM-CSF Antibody GSK3196165 in Subjects with Inflammatory Hand Osteoarthritis - ACR Meeting Abstracts. *A phase IIA study of anti-gm-csf antibody gsk3196165 in subjects with inflammatory hand osteoarthritis*. 2018;70 suppl 1.
57. Ryu JH, Yang S, Shin Y, Rhee J, Chun CH, Chun JS. Interleukin-6 plays an essential role in hypoxia-inducible factor 2 α -induced experimental osteoarthritic cartilage destruction in mice. *Arthritis and Rheumatism*. 2011;63(9):2732-2743. doi:10.1002/art.30451
58. Richette P, Latourte A, Sellam J, et al. (Ethic)Efficacy of tocilizumab in patients with hand osteoarthritis: Double blind, randomised, placebo-controlled, multicentre trial. *Annals of the Rheumatic Diseases*. Published online 2020. doi:10.1136/annrheumdis-2020-218547
59. Frederick ED, Hausburg MA, Thomas GW, Rael LT, Brody E, Bar-Or D. The low molecular weight fraction of human serum albumin upregulates COX2, prostaglandin E2, and prostaglandin D2 under inflammatory conditions in osteoarthritic knee synovial fibroblasts. *Biochemistry and Biophysics Reports*. 2016;8:68-74. doi:10.1016/j.bbrep.2016.08.015
60. Cole B, McGrath B, Salottolo K, Bar-Or D. LMWF-5A for the treatment of severe osteoarthritis of the knee: Integrated analysis of safety and efficacy. *Orthopedics*. 2018;41(1):e77-e83. doi:10.3928/01477447-20171114-05
61. Fuggle NR, Cooper C, Oreffo ROC, et al. Alternative and complementary therapies in osteoarthritis and cartilage repair. *Aging Clinical and Experimental Research*. 2020;32(4):547-560. doi:10.1007/s40520-020-01515-1
62. Aggarwal BB, Gupta SC, Sung B. Curcumin: An orally bioavailable blocker of TNF and other pro-inflammatory biomarkers. *British Journal of Pharmacology*. 2013;169(8):1672-1692. doi:10.1111/bph.12131
63. UNITY Biotechnology Announces 12-week data from UBX0101 Phase 2 Clinical Study in Patients with Painful Osteoarthritis of the Knee | Unity Biotechnology. Accessed March 2, 2021. <https://ir.unitybiotechnology.com/news-releases/news-release-details/unity-biotechnology-announces-12-week-data-ubx0101-phase-2>
64. Bourin P, Bunnell BA, Casteilla L, et al. Stromal cells from the adipose tissue-derived stromal vascular fraction and culture expanded adipose tissue-derived stromal/stem cells: A joint statement of the International Federation for Adipose Therapeutics and Science (IFATS) and the International Society for Cellular Therapy (ISCT). *Cytotherapy*. 2013;15(6):641-648. doi:10.1016/j.jcyt.2013.02.006
65. Barry F, Murphy M. Mesenchymal stem cells in joint disease and repair. *Nature Reviews Rheumatology*. 2013;9(10):584-594. doi:10.1038/nrrheum.2013.109
66. Manferdini C, Maumus M, Gabusi E, et al. Adipose-derived mesenchymal stem cells exert antiinflammatory effects on chondrocytes and synoviocytes from osteoarthritis patients through prostaglandin E2. *Arthritis and Rheumatism*. 2013;65(5):1271-1281. doi:10.1002/art.37908
67. Murphy JM, Dixon K, Beck S, Fabian D, Feldman A, Barry F. Reduced chondrogenic and adipogenic activity of mesenchymal stem cells from patients with advanced osteoarthritis. *Arthritis and Rheumatism*. 2002;46(3):704-713. doi:10.1002/art.10118
68. Murphy JM, Fink DJ, Hunziker EB, Barry FP. Stem Cell Therapy in a Caprine Model of Osteoarthritis. *Arthritis and Rheumatism*. 2003;48(12):3464-3474. doi:10.1002/art.11365
69. Kim SH, Ha CW, Park YB, Nam E, Lee JE, Lee HJ. Intra-articular injection of mesenchymal stem cells for clinical outcomes and cartilage repair in

- osteoarthritis of the knee: a meta-analysis of randomized controlled trials. *Archives of Orthopaedic and Trauma Surgery*. 2019;139(7):971-980. doi:10.1007/s00402-019-03140-8
70. Chahal J, Gómez-Aristizábal A, Shestopaloff K, et al. Bone Marrow Mesenchymal Stromal Cell Treatment in Patients with Osteoarthritis Results in Overall Improvement in Pain and Symptoms and Reduces Synovial Inflammation. *Stem Cells Translational Medicine*. 2019;8(8):746-757. doi:10.1002/sctm.18-0183
 71. Turner L, Knoepfler P. Selling Stem Cells in the USA: Assessing the Direct-to-Consumer Industry. *Cell Stem Cell*. 2016;19(2):154-157. doi:10.1016/j.stem.2016.06.007
 72. Bennell KL, Hunter DJ, Paterson KL. Platelet-Rich Plasma for the Management of Hip and Knee Osteoarthritis. *Current Rheumatology Reports*. 2017;19(5). doi:10.1007/s11926-017-0652-x
 73. Andia I, Maffulli N. Platelet-rich plasma for managing pain and inflammation in osteoarthritis. *Nature Reviews Rheumatology*. 2013;9(12):721-730. doi:10.1038/nrrheum.2013.141
 74. Migliorini F, Driessen A, Quack V, et al. Comparison between intra-articular infiltrations of placebo, steroids, hyaluronic and PRP for knee osteoarthritis: a Bayesian network meta-analysis. *Archives of Orthopaedic and Trauma Surgery*. 2020;13. doi:10.1007/s00402-020-03551-y
 75. Medina-Porqueres I, Ortega-Castillo M, Muriel-García A. Effectiveness of platelet-rich plasma in the management of hip osteoarthritis: a systematic review and meta-analysis. *Clinical Rheumatology*. Published online 2020. doi:10.1007/s10067-020-05241-x
 76. Evans A, Ibrahim M, Pope R, et al. Treating hand and foot osteoarthritis using a patient's own blood: A systematic review and meta-analysis of platelet-rich plasma: PRP for Small Joint Osteoarthritis. *Journal of Orthopaedics*. 2020;18:226-236. doi:10.1016/j.jor.2020.01.037
 77. C M, O B, JF K. Responders to Platelet-Rich Plasma in Osteoarthritis: A Technical Analysis. *BioMed research international*. 2017;2017. doi:10.1155/2017/7538604
 78. Troeberg L, Nagase H. Proteases involved in cartilage matrix degradation in osteoarthritis. *Biochimica et Biophysica Acta – Proteins and Proteomics*. 2012;1824(1):133-145. doi:10.1016/j.bbapap.2011.06.020
 79. Heinegård D, Saxne T. The role of the cartilage matrix in osteoarthritis. *Nature Publishing Group*. 2010;7:50-56. doi:10.1038/nrrheum.2010.198
 80. Krzeski P, Buckland-Wright C, Bálint G, et al. Development of musculoskeletal toxicity without clear benefit after administration of PG-116800, a matrix metalloproteinase inhibitor, to patients with knee osteoarthritis: A randomized, 12-month, double-blind, placebo-controlled study. *Arthritis Research and Therapy*. 2007;9(5). doi:10.1186/ar2315
 81. van der Aar EM, Desrivot J, Fagard L, et al. ADAMTS-5 inhibitor GLPG1972, a potential new treatment in osteoarthritis, shows favorable safety, pharmacokinetics and pharmacodynamics in healthy subjects. *Osteoarthritis and Cartilage*. 2018;26:S310. doi:10.1016/j.joca.2018.02.623
 82. Miller RE, Ishihara S, Tran PB, et al. An aggrecan fragment drives osteoarthritis pain through Toll-like receptor 2. *JCI insight*. 2018;3(6). doi:10.1172/jci.insight.95704
 83. Galapagos and Servier report topline results for ROCCELLA Phase 2 clinical trial with GLPG1972/S201086 in knee osteoarthritis patients – Servier. Accessed March 5, 2021. <https://servier.com/en/communique/galapagos-and-servier-report-topline-results-for-roccella-phase-2-clinical-trial-with-glp1972-s201086-in-knee-osteoarthritis-patients/>
 84. Lindström E, Rzoska B, Henderson I, et al. Nonclinical and clinical pharmacological characterization of the potent and selective cathepsin K inhibitor MIV-711. *Journal of Translational Medicine*. 2018;16(1). doi:10.1186/s12967-018-1497-4
 85. Conaghan PG, Bowes MA, Kingsbury SR, et al. Disease-Modifying Effects of a Novel Cathepsin K Inhibitor in Osteoarthritis. *Annals of Internal Medicine*. 2020;172(2):86. doi:10.7326/M19-0675
 86. Mcguire, Segal, Metyas, Barthel, Miller. Intra-Articular TPX-100 in Knee Osteoarthritis: Robust Functional Response at 6 and 12 Months Is Associated with Increased TibioFemoral Cartilage Thickness – ACR Meeting Abstracts. *Arthritis Rheumatol*. 2018;70 suppl 1.
 87. Wang Y, Fan X, Xing L, Tian F. Wnt signaling: A promising target for osteoarthritis therapy. *Cell Communication and Signaling*. 2019;17(1). doi:10.1186/s12964-019-0411-x
 88. Deshmukh V, O'Green AL, Bossard C, et al. Modulation of the Wnt pathway through inhibition of CLK2 and DYRK1A by lorecivivint as a novel, potentially disease-modifying approach for knee osteoarthritis treatment. *Osteoarthritis and Cartilage*. 2019;27(9):1347-1360. doi:10.1016/j.joca.2019.05.006
 89. Yazici Y, McAlindon TE, Gibofsky A, et al. Lorecivivint, a Novel Intra-articular CLK/DYRK1A Inhibitor and Wnt Pathway Modulator for Treatment of Knee Osteoarthritis: A Phase 2 Randomized Trial. *Arthritis & Rheumatology*. Published online May 20, 2020. doi:10.1002/art.41315
 90. Kim MK, Ha CW, In Y, et al. A Multicenter, Double-Blind, Phase III Clinical Trial to Evaluate the Efficacy and Safety of a Cell and Gene Therapy in Knee Osteoarthritis Patients. *Human Gene Therapy Clinical Development*. 2018;29(1):48-59. doi:10.1089/humc.2017.249
 91. Laslett LL, Doré DA, Quinn SJ, et al. Zoledronic acid reduces knee pain and bone marrow lesions over 1 year: A randomised controlled trial. *Annals of the Rheumatic Diseases*. 2012;71(8):1322-1328. doi:10.1136/annrheumdis-2011-200970
 92. Vaysbrot EE, Osani MC, Musetti M-C, McAlindon TE, Bannuru RR. Are bisphosphonates efficacious in knee osteoarthritis? A meta-analysis of randomized controlled trials. *Osteoarthritis and Cartilage*. 2018;26(2):154-164. doi:10.1016/j.joca.2017.11.013
 93. Runhaar J, Deroisy R, van Middelkoop M, et al. The role of diet and exercise and of glucosamine sulfate in the prevention of knee osteoarthritis: Further results from the PRevention of knee Osteoarthritis in Overweight Females (PROOF) study. *Seminars in Arthritis and Rheumatism*. 2016;45(4):S42-S48. doi:10.1016/j.semarthrit.2015.11.001
 94. Gregori D, Giacobelli G, Minto C, et al. Association of Pharmacological Treatments with Long-term Pain Control in Patients with Knee Osteoarthritis: A Systematic Review and Meta-analysis. In: *JAMA – Journal of the American Medical Association*. Vol 320. American Medical Association; 2018:2564-2579. doi:10.1001/jama.2018.19319
 95. ICMJE | Recommendations | Clinical Trials. Accessed March 5, 2021. <http://www.icmje.org/recommendations/browse/>
 96. Gopal AD, Wallach JD, Aminawung JA, et al. Adherence to the International Committee of Medical Journal Editors' (ICMJE) prospective registration policy and implications for outcome integrity: a cross-sectional analysis of trials published in high-impact specialty society journals. *Trials*. 2018;19(1):448. doi:10.1186/s13063-018-2825-y
 97. Thiese M. Observational and interventional study design types; an overview. *Biochemia medica*. 2014;24(2):199-210. doi:10.11613/BM.2014.022
 98. Vincent T, Malfait A-M. Time to be positive about negative data? 2017;25(3):351-353. doi:10.1016/j.joca.2017.01.016
 99. van Helvoort EM, van Spil WE, Jansen MP, et al. Cohort profile: The Applied Public-Private Research enabling OsteoArthritis Clinical Headway (IM1-APPROACH) study: a 2-year, European, cohort study to describe, validate and predict phenotypes of osteoarthritis using clinical, imaging and biochemical markers. *BMJ open*. 2020;10(7):e035101. doi:10.1136/bmjopen-2019-035101
 100. Sherwood J. Osteoarthritis year in review 2018: biology. *Osteoarthritis and Cartilage*. 2019;27(3):365-370. doi:10.1016/j.joca.2018.10.005

Table 1 Phase II and phase III OA trials investigating efficacy of pharmacological interventions with a completion date in 2017 or later that interfere with pain pathways

Intervention	Mechanism (assumed)	Target	N	Target joint	Randomized controlled trials N, %	Double blind N, %	Placebo controlled N, %	Placebo controlled
<i>Diclofenac, Ibuprofen, Ketoprofen, Multiprofen, Naproxen</i>	NSAIDs	COX	10	9 × knee, 1 × lumbar spine	10, 100	9, 90	6, 60	NCT03081806^a NCT03110523^a NCT03434197^b NCT04421911^b NCT03978208^b NCT03199417 ^d NCT03691844 ^c NCT03172780 ^c NCT03277066 ^c NCT03691818 ^c
<i>Difelikefalin (CR845)</i>	GPCR – kappa opioid receptor agonist	Opioid receptor	1	1 × knee and hip	1, 100	1, 100	1, 100	NCT02944444 ^{8c}
<i>Naltrexon</i>	GPCR – Opioid receptor antagonists	Opioid receptor	2	2 × Not defined	2, 100	2, 100	2, 100	NCT03008590 ^c NCT04115020 ^d
<i>Tramadol, Celecoxib (YUC301)</i>	GPCR – nonselective opioid receptor agonist, NSAID	Opioid and COX receptor	1	1 × knee	1, 100	0, 0	0, 0	NCT03850587^a
<i>Cannabidiol (CBD, THC)</i>	GPCR – Cannabinoid receptor	Cannabinoid receptor	5	4 × knee, 1 × hand	4, 80	4, 80	3, 60	NCT03825965^a NCT04412837^a NCT03693833^b NCT04195269^b NCT02324777 ^e
<i>Capsaicin, Transcapsaicin, Resiniferatoxin</i>	Ion channels	TRPV1 receptor	9	9 × knee	9, 100	8, 89	8, 89	NCT03661996^b NCT03429049^b NCT03660943^b NCT04044742^a NCT04386980^a NCT03153813 ^d NCT03528369 ^c NCT02558439 ^c NCT03028870 ^c
<i>Fasimumab and Tanezumab</i>	Monoclonal antibody	NGF pathway	10	10 × knee, 10 × hip, 1 × shoulder	9, 90	9, 90	8, 80	NCT03161093^b NCT03304379^b NCT03691974^b NCT02683239^b NCT03245008^b NCT03285646 ^c NCT02528188 ^c NCT02674386 ^c NCT02697773 ^c NCT02709486 ^c
LY3016859	Monoclonal antibody	EGF inhibitor, TGFα inhibitor	1	1 × knee	1, 100	1, 100	1, 100	NCT04456686^b

Intervention	Mechanism (assumed)	Target	N	Target joint	Randomized controlled trials N, %	Double blind N, %	Placebo controlled N, %	Placebo controlled
GZ389988, ASP7962, ONO-4474	Tropomyosin receptor kinase inhibitors	NGF pathway	3	3 × knee	3, 100	3, 100	3, 100	NCT02845271 ^c NCT02611466 ^c NCT02997696 ^d
REGN5069,	Monoclonal antibody	GFRalpha3	1	1 × knee	1, 100	1, 100	1, 100	NCT03956550^d
<i>Botulinum toxin A</i>	ACh inhibitors; Glutamate antagonists; Membrane transport protein modulators; Neuromuscular blocking agents	Neuro-muscular junction and noncholinergic neurons	3	2 × knee, 1 × hand	3, 100	2, 67	1, 33	NCT03726788^a NCT03187626^b NCT02832713^b
<i>Duloxetine</i>	non-selective serotonin reuptake inhibitor	Serotonin-receptor	2	2 × knee	2, 100	1, 50	1, 50	NCT04224584^b NCT04504812^a
<i>Oxytocin</i>	Oxytocin agonist	Para-sympatric stimulation	2	2 × knee	0, 0	0, 0	0, 0	NCT04429880^a NCT04431193^a
<i>Biofreeze 4 Topical Gel</i>	TRPM8 channels, vasodilatation	TRPM8 channel	1	1 × knee	1, 100	1, 100	1, 100	NCT04351594^a
<i>Oxygen-ozone therapy</i>	prostaglandin synthase inhibitor	Prostaglandin synthase inhibitor	1	1 × knee	1, 100	1, 100	0, 0	NCT04426721^b
<i>3VM1001 copper cream</i>	Unknown	Unknown	1	1 × knee	1, 100	1, 100	1, 100	NCT03142178 ^c

N Number of studies, NSAID nonsteroidal anti-inflammatory drugs, GPCR G-protein coupled receptor, COX cyclooxygenase enzymes, CBD cannabidiol, THC tetrahydrocannabinol, TRPV1 transient receptor potential vanilloid 1, NGF nerve growth factor, EGF epidermal growth factor, TGFα transforming growth factor, ACh acetylcholine, TRPM transient receptor potential ion channels.
Study status in clinicaltrials.gov November 2020 indicated in superscript:

a Not yet recruiting

b Recruiting or active, not recruiting

c Completed with- or without results

d Terminated or withdrawn

e Unknown

NCT numbers of ongoing studies, are in bold font

Table 2 Phase II and III OA trials investigating efficacy of pharmacological interventions with a completion date in 2017 or later that intend to interfere with inflammation

Intervention	Mechanism (assumed)	Target	N	Target joint	Randomized controlled trials N, %	Double blind N, %	Placebo controlled N, %	NCT nrs
<i>Corticosteroid (Fluticasone, Zilretta, sustained release Dexamethasone)</i>	Corticosteroid	Glucocorticoid receptor	11	7x knee, 3x hip, 2x shoulder	8,73	4,36	5,45	NCT04120402^a NCT04123561^b NCT03754049^b NCT04065074 ^c NCT04160091 ^d NCT03793010 ^d NCT03046446 ^c NCT03382262 ^c NCT03378076 ^c NCT03529942 ^c NCT03005873 ^c
<i>Diacerein</i>	Anthraquinone derivative	IL-1	2	2x knee	2,100	2,100	2,100	NCT04318041^a NCT02688400^a
<i>Adalimumab</i>	TNF- α antibody	TNF- α	2	2x knee	2,100	2,100	1,50	NCT02471118^b NCT02893098^b
<i>Otilimab (GSK3196165, MOR103)</i>	Granulocyte macrophage colony stimulating factor antibody (GM-CSF)	GM-CSF	1	hand	1,100	1,100	1,100	NCT02683785 ^c
<i>Tocilizumab</i>	Anti-IL-6 receptor monoclonal antibody	IL-6	1	hand	1,100	1,100	1,100	NCT02477059^b
<i>XT-150: gene therapy expressing IL-10</i>	Immuno-modulation	IFN- γ , IL-2, IL-3, TNF- α , GM-CSF inhibition	1	Knee	1,100	1,100	1,100	NCT04124042^b
<i>LMWF-5A, DMI9523</i>	Immuno-modulation	TNF- α , IL-6 and IL-7 among others	3	3x knee	2,67	2,67	2,67	NCT03988023^b NCT03182686 ^c NCT03349645 ^d
<i>Curcumin</i>	Presumed inhibition to the release of inflammatory through NLRP3	NLRP3	1	1x Not defined	1,100	1,100	1,100	NCT03715140^b
<i>Resveratrol</i>	Immuno-modulation	Several targets (T- and B-lymphocytes)	1	Knee	1,100	1,100	1,100	NCT02905799^b

Intervention	Mechanism (assumed)	Target	N	Target joint	Randomized controlled trials N, %	Double blind N, %	Placebo controlled N, %	NCT nrs
<i>UBX0101</i>	p53, MDM2 interaction inhibitor	p53, MDM2	1	knee	1,100	1,100	1,100	NCT04129944 ^c
<i>Piclidenoson (CF101, IB-MECA)</i>	modulation of the nuclear factor- κ B (NF- κ B) and the Wnt signal transduction pathways	A3 adenosine receptor (A3AR) agonist IL-17, IL-23	1	Knee	1,100	1,100	1,100	NCT00837291 ^d

n Number of studies, *TNF- α* tumor necrosis factor alpha, *LMWF-5A* low-molecular-weight fraction of 5% human serum albumin, *IL* interleukin, *NLRP3* NLR family pyrin domain containing 3, *GM-CSF* granulocyte macrophage colony stimulating factor, *ADORA3* Adenosine A3 receptor agonist, *MDM2* mouse double minute 2 homolog. Study status in clinicaltrials.gov November 2020 indicated in superscript:

a Not yet recruiting,

b Recruiting or active, not recruiting

c Completed with- or without results

d Terminated or withdrawn

e Unknown.

NCT numbers of ongoing studies are in bold

Table 3 Phase II and III OA trials investigating efficacy of pharmacological interventions with a completion date in 2017 or later which investigate interventions with mesenchymal stem cells

Intervention	Mechanism (assumed)	Target	N	Target joint	Randomized controlled trials N, %	Double blind N, %	Placebo controlled N, %	NCT numbers
Mesenchymal Stem Cells (adipose tissue-derived)	Regenerative capacity	Several targets	26	23x knee 3x shoulder 3x hip 1x not defined	15, 58	10, 39	7, 28	NCT04368806^a NCT03984461^b NCT04351932^a NCT04230902^b NCT04208646^a NCT03990805^b NCT04050111^a NCT04448106^a NCT04427930^b NCT03955497^b NCT04321629^b NCT03509025^b NCT03308006^a NCT02838069^b NCT02784964^b NCT02844738^b NCT02844764^b NCT02844751^b NCT03467919 ^b NCT03869229 ^b NCT02846675 ^c NCT03164083 ^d NCT02674399 ^c NCT02351011 ^c NCT02967874 ^c NCT02827851 ^e
Mesenchymal Stem Cells (placenta, umbilical cord, Wharton's jelly derived)	Regenerative capacity	Several targets	15	14x knee 1x hip 1x shoulder 1x not defined	10, 67	6, 40	3, 20	NCT03383081^b NCT04520945^a NCT04453111^b NCT04314661^b NCT04313894^b NCT03485157^b NCT03866330^b NCT03390920^b NCT03166865 ^e NCT02580695 ^c NCT02237846 ^d NCT03441607 ^e NCT02776943 ^e NCT03028428 ^e NCT01733186 ^c
Mesenchymal Stem Cells (bone-marrow derived)	Regenerative capacity	Several targets	9	9x knee	7, 78	7, 78	2, 22	NCT04351932^a NCT04240873^b NCT04205656^b NCT03818737^b NCT03589287^b NCT03876795^b NCT02848027^b NCT03271229 ^d NCT02958267 ^c

Mesenchymal Stem Cells (unknown origin)	Regenerative capacity	Several targets	1	1x knee	1, 100	0, 0	0, 0	NCT03975101 ^d
Platelet-rich plasma	Regenerative capacity	Several targets	15	11x knee 2x hip 1x shoulder 1x not defined	12, 80	6, 40	3, 20	NCT03984461^b NCT03477630^b NCT02776514^b NCT02844738^b NCT02844764^b NCT04333160^b NCT04205656^b NCT03491761^b NCT03889925^b NCT04352075 ^c NCT04331327 ^c NCT03138317 ^e NCT01697423 ^e NCT02694146 ^c
Autologous conditioned serum	Regenerative capacity	Several targets	1	1x knee	0, 0	0, 0	0, 0	NCT03850080 ^c

N Number of studies.

Study status in clinicaltrials.gov November 2020 indicated in superscript:

a Not yet recruiting

b Recruiting or active, not recruiting

c Completed with- or without results

d Terminated or withdrawn

e Unknown

For ongoing studies, NCT numbers are in bold

Table 4 Phase II and III OA trials investigating efficacy of pharmacological interventions with a completion date in 2017 or later, which interfere with cartilage regeneration or bone resorption or involve viscosupplementation

Intervention	Mechanism (assumed)	Target	N	Target joint	Randomized controlled trials N, %	Double blind N, %	Placebo controlled N, %	NCT nr.
GLPG1972, M6495	ADAMTS-5 inhibitors	ADAMTS-5	2	2X Knee	2,100	2,100	2,100	NCT03595618 ^C NCT03583346 ^C
MIV-711	Selective cathepsin-K inhibitor	CathepsinK	2	2X Knee	1,50	1,50	1,50	NCT02705625 ^C , NCT03037489 ^C
LRX712, TPX-100	Regeneration and repair of cartilage	Chondroprogenitor cells	2	2X Knee	2,100	2,100	2,100	NCT04097379^b NCT02837900 ^C
Lorecivivint (SMO4690)	DYRK kinase inhibitors; Wnt signalling pathway inhibitors	Wnt signalling	7	7X Knee	6,86	6,86	6,86	NCT04520607^b NCT04385303^b NCT03706521^b NCT03727022^b NCT03928184^b NCT03122860 ^C NCT02536833 ^C
TissueGene-C (Invossa K)	TGF-overexpressing Chondrocyte suppletion	Chondrocytes	3	3X knee	3,75	3,75	3,75	NCT03383471^b NCT03291470^a NCT03203330^b
CartiLife	Chondrocyte suppletion	Chondrocytes	1	1X knee	1,100	0,0	0,0	NCT03545269 ^C
Zoledronic acid	Bisphosphonates	Osteoclasts	2	1X knee, 1X hip	2,100	2,100	2,100	NCT04303026^b NCT02746068^b
Denosumab, Teriparatide	Calcium regulating compounds	Osteoclasts, osteoblasts	2	1X knee, 1X hand	2,100	2,100	2,100	NCT02771860^b NCT03072147^b
Alfacalcidol	Osteocyte/chondrocyte hypertrophy by Vit. D substitution	Osteoclasts	1	1X knee	1,100	1,100	1,100	NCT04405960 ^C
Losartan	Enhanced articular cartilage repair after microfracturing	Chondrocytes	1	1X hip	1,100	1,100	1,100	NCT04212650^b
Hyaluronic acid, some with supplements of triamcinolon, mannitol or diclofenac	Visco-supplementation	-	10	9X knee, 1X hip	10,100	9,90	6,60	NCT04231318^b NCT03561779 ^e NCT03209362 ^C NCT04315103 ^C NCT03190369 ^C NCT03191903 ^C NCT03390036 ^C NCT03200288 ^C NCT02698865 ^d NCT03636971 ^C
SB-061	Aggrecan mimic	-	2	2X knee	2,100	2,100	2,100	NCT02802709 ^C NCT03231280 ^C

Intervention	Mechanism (assumed)	Target	N	Target joint	Randomized controlled trials N, %	Double blind N, %	Placebo controlled N, %	NCT nr.
MM-II	Visco-supplementation	-	1	1X knee	1,100	1,100	1,100	NCT04506463^a
Collagen-PVP	Visco-supplementation	-	1	1X Knee	1,100	1,100	0,100	NCT04019782^b
Glucosamine with Chondroitin, glucosamine with Meloxicam	Synthesis of synovial fluid	-	2	2X knee	2,100	2,100	1,50	NCT03936192^a NCT02830919 ^C

N Number of studies, ADAMTS metalloproteinase with a thrombospondin type 1 motif, DYRK dual-specificity tyrosine phosphorylation-regulated kinase, Wnt wingless-related integration site
Study status in clinicaltrials.gov November 2020 indicated in superscript:

a Not yet recruiting

b Recruiting or active, not recruiting

c Completed with- or without results

d Terminated or withdrawn

e Unknown

For ongoing studies, NCT numbers are in bold

CHAPTER 6

Safety, tolerability, pharmacokinetics and pharmacodynamics of single ascending doses of LRX712 in patients with knee osteoarthritis: a randomized placebo-controlled phase I trial

This chapter is a partial draft of the contemplated overarching paper, which will cover the pre-clinical and early clinical development of LRX712. Authors of a final paper are to be determined.

J.P.M. Vrouwe¹, F.E. Stuurman¹, J. Burggraaf^{1,2}, L.A. Coleman³.

This chapter (pages 125 to 140) is subject to an embargo and is therefore not included in this book. A separate quire of the chapter is used during the defence.

1 Centre for Human Drug Research, Leiden, NL

2 LACDR, Leiden, NL

3 Novartis Institutes for Biomedical Research, Cambridge, USA

ABSTRACT

BACKGROUND Osteoarthritis (OA) is a highly prevalent and debilitating disease, for which no disease modifying drugs are registered. LRX712 stimulates chondrocyte proliferation *in vitro* and in pre-clinical models. The objectives of this first-in-human (FIH) study were to evaluate safety, tolerability, and pharmacokinetics (PK) of single ascending doses of intra-articular (i.a.) injection of LRX712 into the target knee of patients with mild-to-moderate OA.

METHODS This double-blind, randomized, placebo-controlled, single ascending dose study included seven cohorts. At baseline, patients were randomized 4:2 to LRX712 (doses 0.5mg to 75mg) or placebo. During the 60-day follow-up period, patients were monitored for safety, tolerability, and PK.

RESULTS Forty-two patients were included; 28 were treated with a single dose of LRX712 and 14 received placebo. No serious adverse events occurred. The most frequently observed AEs were injection site joint pain or discomfort, which occurred more frequently in the higher dose groups. A pattern of transient elevations in high sensitivity C-reactive protein (hsCRP) post-administration was identified, primarily with dose levels of LRX712 > 15 mg. Pharmacokinetic analysis showed longer $T_{1/2}$ at higher dose levels, with large variation between subjects.

CONCLUSIONS The results of this first-in-human study indicated that LRX712 has a safety, tolerability and PK profile that supports further development including exploration of risk-benefit in the dose range most likely to be efficacious based on preclinical data. These clinical data suggest that intra-articular injection of LRX712 into the knee can be performed safely in patients with knee OA.

Introduction

Knee osteoarthritis (OA) is a highly prevalent and debilitating degenerative joint disease. The world-wide prevalence is estimated to be 13.5% in the population aged 40 years and over.¹ Its cause is heterogeneous and multifactorial: risk factors include a history of traumatic joint injury, obesity, aging, biomechanical factors, and hereditary factors.²⁻⁴

Clinically, knee OA manifests as joint pain, stiffness, swelling and loss of normal joint function.⁵ The diagnosis is confirmed radiologically and characterized by joint space (cartilage) loss, osteophytes, subchondral bone marrow lesions and synovitis.^{6,7}

Current therapies in knee OA are limited to symptomatic treatment which is achieved by lifestyle changes, patient education, local or systemic administration of analgesics or corticosteroid injections and – at a late stage – joint replacement.^{5,8} As the safety and efficacy of currently applied analgesics (non-steroid anti-inflammatory drugs (NSAIDs) and opioids) and corticosteroids are limited, there is a clear need for disease modifying osteoarthritis drugs (DMOADs).^{9,10} No approved chondro-protective or chondro-regenerative agents, capable of slowing down (or reversing) the degenerative process in OA, are available yet.^{5,8,11,12} And several strategies for DMOAD development are currently researched.¹³

One approach toward disease modification is to stimulate cartilage formation. In healthy tissue, cartilage stem progenitor cells (CSPCs) differentiate into chondrocytes and form or repair (in cases where tissue is damaged) hyaline articular cartilage without induction of fibrosis, hypertrophy and ossification.¹⁴ By mimicking pathophysiological pathways, the CSPCs may be stimulated to stop the degenerative progress in osteoarthritic cartilage and amplify the restoration of damaged cartilage.¹⁴⁻¹⁶

LRX712 is a compound that could be used for that purpose as it shows cellular differentiation of CSPCs and formation of hyaline cartilage both *in vitro* and in animal studies (unpublished data). LRX712 is a small molecule found by phenotypic screening. LRX712 is metabolized in the liver through N-oxidation into its major (inactive) metabolite, MAE344.

This first-in-human (FIH) study of LRX712 aimed to evaluate the safety, tolerability, and pharmacokinetics (PK) of single ascending doses of i.a. injection of LRX712 into the knee of patients with mild-to-moderate knee OA.

Materials and methods

STUDY DESIGN

This was a single center, FIH, double-blind, randomized, placebo-controlled, single ascending dose study, performed at the Centre for Human Drug Research, Leiden, The Netherlands. The study was approved by the medical ethics committee “Foundation Beoordeling Ethiek Biomedisch Onderzoek”, Assen, The Netherlands, and was conducted in accordance with the Dutch law on research in humans. The trial was registered in clinical trial register [clintrials.gov](https://clinicaltrials.gov) under NCT03355196.

Seven consecutive cohorts were studied, each with six patients with knee OA who received a single dose of LRX712, ranging from 0.5 mg to 75 mg, or placebo (4:2). After the i.a. injection, patients were observed in a clinical setting for four days; thereafter, follow-up visits took place on days 8, 11, 15, 22 and 29 with a final follow-up phone call on day 60.

For each dose level, sentinel dosing in the first two patients was applied (one active, one placebo). After blinded safety review of their five-day safety results, the remaining patients were dosed. Safety review- and dose escalation decisions were based on findings from physical examination, ECGs, vital signs, standard clinical laboratory evaluations (hematology, chemistry, urinalysis), adverse events (AEs) and available PK results.

PATIENTS

In a 35-day screening period, patients were screened for in- and exclusion criteria after obtaining written informed consent. Males and females, 30-65 years old, with radiologically confirmed mild-to-moderate knee OA (grades I-III according to Kellgren-Lawrence classification (KL) as determined on weight bearing X-ray within 6 months prior to enrollment), were enrolled.⁶ The main exclusion criteria were a BMI <18 or >32 kg/m², significant abnormalities in blood pressure, 12-lead ECG, routine safety laboratory (hematology, chemistry, coagulation, virology) results, and the use of strong CYP3A4 inhibitors or inducers. Women had to be post-menopausal or surgically sterile and men had to use contraception. Patients were excluded in case of any i.a. treatment of the affected knee within 12 weeks prior to screening or if they used corticosteroids in any administration route other than topically. Paracetamol and NSAIDs could be used as rescue medication.

INVESTIGATIONAL PRODUCT

LRX712 and placebo (NaCl 0.9%; B. Braun Miniplasco) were administered by ultrasound guided i.a. injection. The doses of LRX712 were 0.5 mg, 2.5 mg, 5 mg, 15 mg, 25 mg, 40 mg, or 75 mg of LRX712 and all injections had a volume of 3 mL. As the appearance of LRX712 and placebo were different, the administrations were performed by an independent physician and the subject was blindfolded during the administration to maintain the blind.

ENDPOINTS

A full overview of the schedule of assessments is given in supplementary table 1.

Safety

The primary endpoint was safety, which included monitoring of AEs, physical examinations, vital signs, blood pressure, standard clinical laboratory evaluations (hematology, chemistry, urinalysis), and 12-lead ECG. Holter ECG-monitoring was applied from 24 hours before dosing until 96 hours post dose. In addition, a post-study analysis of hsCRP was performed using a latex-enhanced immunoturbidimetric assay by Siemens Advia Chemistry XPT (Siemens, Germany) with a reportable range of 0.16mg/L to 200.00mg/L for analysis of systemic outcomes.

Pharmacokinetics

For the PK evaluation of LRX712 and metabolite MAE344 in plasma, blood samples were obtained pre-dose, and at regular intervals post-dose (Supplementary table 1). After collection, the samples were centrifuged for 10 minutes at 4°C and 2000xg, and the separated plasma was stored at -70°C within 90 minutes after collection. When possible, synovial fluid sampling was performed pre-dose and after 4 days to explore the synovial fluid concentrations of LRX712 and its metabolite.

LRX712 and metabolite MAE344 concentrations were determined in plasma and synovial fluid using validated Liquid Chromatography with tandem mass spectrometry (LC-MS/MS) methods. The lower limits of quantification (LLQ) for LRX712 and MAE344 were 0.025 and 0.1 ng/mL for plasma, respectively, and 20 and 80 ng/mL for synovial fluid, respectively.

The plasma concentration-time profiles were analyzed using non-compartmental modelling using the software package Phoenix WinNonlin v.8.0

(Certara, Princeton, NJ, USA). The PK parameters for LRX712 included the maximal concentration (C_{max}), the time to reach maximal plasma concentration after drug administration (T_{max}), area under the plasma concentration curve until the last measurement (AUC_{last}), area under the plasma concentration curve to infinity (AUC_{inf}), terminal half-life ($T_{1/2}$), apparent volume of distribution (Vz/F) and clearance (CL/F). In addition, dose-normalized parameters were calculated for C_{max} , AUC_{last} and AUC_{inf} . For LRX712 metabolite MAE344, C_{max} , T_{max} , AUC_{last} , AUC_{inf} and $T_{1/2}$ were calculated.

STATISTICAL ANALYSIS

The sample size was based on clinical considerations and the chance to observe AEs in this sample size. In case of an AE incidence of 33%, there would be an 80% chance of observing that AE within the 4 patients on active drug in one cohort, leading to the described group size. Safety and tolerability evaluation were based on descriptive statistics.

Results

PATIENTS

A total of 134 patients with knee OA were screened and 42 patients were included in the study; see CONSORT flow diagram in Figure 1.¹⁷ The main reason for exclusion was uncontrolled high blood pressure at screening. All included patients completed the study. The demographic characteristics are summarized in Table 1. The randomized study population had a mean age of 57.1 years (range 30-65 years), 29 patients (69%) were female, and the mean BMI was 26.33 kg/m² (range 19.6-33.3 kg/m²). Most patients were Caucasian (92.9%).

ASSESSMENTS

Safety

An overview of the AEs observed during the study conduct, is shown in Table 2. No deaths, serious AEs or severe AEs occurred. A total of 34 patients (81.0%) experienced at least one AE, of which 27 patients received LRX712 (96% of LRX) and 7 patients received placebo (50% of placebo). The most reported AEs were injection site conditions (33 AEs in 20 patients, 47.6% of all randomized patients), headache (12 AEs in 12 patients, 28.6%) and back pain (8 AEs in 8 patients, 19.0%). Thirty-four patients (81%) had AEs of mild severity, of whom 6 patients (14.3%) also had an AE of moderate severity (5 patients

had an injection site reaction and 1 patient had an episode of hyperventilation of 1 hr). The mild and moderate injection site reactions included discomfort, pain, stiffness, swelling, limited range of motion, hematoma, and dullness. All injection site conditions were self-limiting, and their duration varied from several hours to eight days.

A pattern of transient elevations in high sensitivity C-reactive protein (hsCRP) post-administration was identified, primarily with dose levels of LRX712 > 15 mg. Furthermore, occasionally out-of-range values were observed in vital signs, ECG, blood chemistry, hematology, and urinalysis, but no abnormalities of clinical significance were found during the study. In the 24-hour holter monitoring no clinically significant abnormalities, or dose related trends were observed either.

Pharmacokinetics

The plasma PK data of LRX712 and its metabolite MAE344 are shown in Figure 2 and summarized in Tables 3 and 4. LRX712 plasma concentrations above the LLOQ were measured in all dose levels. From the 2.5 mg dose level onwards, the plasma concentrations were above the LLOQ for at least one-week post-dose.

Both the C_{max} and AUC_{inf} increased up to 19.3 ng/mL and 1650 hr*ng/mL, respectively, after 75 mg LRX712. Plasma C_{max} seemed to plateau from 25 mg onwards, whereas a less than proportional increase of total exposure (AUC_{inf}) was still observed from 25 to 75 mg. A high inter-patient variability for plasma C_{max} and AUC_{inf} was observed, with coefficient variability values ranging between 54.1% and 107.4% for C_{max} and 32.7% to 66.4% for AUC_{inf} . The time to maximum plasma concentration (T_{max}) was measured between 4 and 6.5 hours in the lower doses (up to 7.5 mg) and increased to a range between 14 and 24 hours for the higher dose levels between 15 and 75 mg.

The PK behavior (Figure 2) as observed in this FIH can be categorized in two types. In the first, observed in the low dose (≤ 7.5 mg) groups and in few patients in the higher dose levels, individual time-concentration profiles show a relatively fast decline of the plasma concentration of LRX712, with an apparent half-life shorter than 48 hours. In the second type, which was more dominant in the higher dose levels, the profile shows a plateau and slow decline of the plasma concentrations, leading to individual $T_{1/2}$ of more than 179 hours in the 15 and 75 mg dose levels. Since both categories occur in the dose levels ≥ 15 mg, a high variability is seen in the PK parameters, including mean $T_{1/2}$ in those groups.

In the 40 mg group, the plateau-type profile of the plasma concentration was observed in two of the four patients. The determination of $T_{1/2}$ in these two patients was not possible due to the combination of the long $T_{1/2}$ and the sampling schedule. Therefore, the reported value for $T_{1/2}$ of this dose level (48.7 hours) is the mean of the two other patients and is an underestimation of the actual $T_{1/2}$ of this cohort.

The decline of the plasma concentrations in the four patients of the 25 mg dose group was faster than in the other patients who had a dose of ≥ 15 mg. This led to a $T_{1/2}$ in the 25 mg group of 32.8 ± 7.2 hours and matches the PK profiles observed in the ≤ 7.5 mg groups, rather than that of majority of patients in the higher dose groups.

LRX712 metabolite MAE344 was measured in plasma and exceeded the exposure of the parent drug. The maximum plasma concentration of MAE344 was reached after 7 to 72 hours. Depending on the dose level, C_{max} and AUC_{inf} were 5- to 12-fold and 12- to 18-fold higher than for LRX712, respectively (Tables 3 and 4).

Post-dose (72 hours) synovial fluid samples could be obtained in nine patients in the active groups. Concentrations ranged between 54.4 to 1900 ng/mL. The highest concentration was observed in the 75 mg dose group, but there was no clear relationship between local concentrations and dose level. The pharmacologically inactive metabolite MAE344 was not detected in synovial fluid.

Discussion

We report the results of a FIH clinical trial, which assessed the safety, tolerability and PK of single ascending doses of i.a. LRX712. The incidence of injection site reactions was higher in the active- than in the placebo group and AE incidence in the 40- and 75 mg dose groups was higher than that of the lower dose groups. Moderate AEs only occurred in the 40- and 75 mg groups.

In the post-study analysis, transiently elevated hs-CRP was observed in 4/9 patients that experienced an injection site reaction in the 25, 40, and 75 mg dose groups. Of the patients who had an injection site reaction of moderate severity, two (33%) had elevated CRP. As such, hs-CRP elevation was observed in some patients who had only mild local AEs and not in all patients who experienced local AEs of moderate severity. In pre-clinical studies (unpublished data) in beagle dogs, reversible inflammation of the knee

joint synovium was observed in a high-dose subgroup of the treated animals, this may be in line with our clinical observations.

Although a difference in AE incidence between placebo- and active groups was apparent, the sample size of the dose groups was small, and results should therefore be interpreted with care. Also, post-procedural joint pain has a high incidence after the i.a. administration of other, registered compounds such as corticosteroids, with a post-injection pain incidence in the range of 33-50%, and a mean duration of 4 days.^{18,19} In the clinic, i.a. injections are commonly combined with a local short-acting local anesthetic, which masks immediate post-injection pain. Such local anesthetics were not applied in this trial.

Although both the C_{max} (up to 25 mg) and AUC_{inf} of LRX712 increased with the dose, no definitive conclusions on dose proportionality can be drawn, due to the large interpatient variability of the PK profiles, in combination with the small sample size per dose level. Thus, the exact reason for the inter-patient variability is not fully understood and will be studied further. On the other hand, it should be considered that the systemic pharmacokinetics are of relative minor importance if it can be established that local concentrations of the drug remain high for a considerable and sufficient time to exert its effect. That said, it appears that high local concentrations of LRX712 lead to an increased AE incidence, which should be taken into account when investigating efficacious dose levels.

Although no effective DMOADs are registered, the search for new disease modifying agents aims at multiple pathways such as inhibition of IL-1-, TNF- α - WNT- or cathepsin K. So far, some positive effects have been observed regarding structural joint changes, but to date there are no studies that found a positive, clinically relevant effect on pain and/or functional outcomes.²²⁻²⁴ This stresses the importance of measurement of these (patient reported) clinical outcomes in a very early stage of drug development.

One of the strengths of this study was the inclusion of a representative the patient population, that for which the compound is ultimately intended. Safety and tolerability of the i.a. injections- and the working mechanism of this compound may be subject to the disease state of the target joints. As LRX712 is most likely to have an effect in patients with mild-to-moderate knee OA, the outcomes of this study are thought representative for the target population. Another strength of this study was the extensive blood sampling for safety and plasma PK. The main limitation is the small sample size per dose level, which precludes firm conclusions about plasma PK behavior seen

in this trial. This study did not aim to investigate (long term) efficacy; hence, the follow-up duration is appropriate for the current study. Any study with the aim to investigate efficacy in OA would require a longer follow-up period, as disease progression is generally slow.

The results of this first-in-human study indicated that LRX712 has a safety, tolerability and PK profile that supports further development including exploration of risk-benefit in the dose range most likely to be efficacious based on preclinical data. These clinical data suggest that intra-articular injection of LRX712 into the knee can be performed safely in patients with knee OA.

REFERENCES

- Cui A, Li H, Wang D et al. Global, regional prevalence, incidence and risk factors of knee osteoarthritis in population-based studies. *EClinicalMedicine*. 2020;29:100587. doi:10.1016/j.eclinm.2020.100587
- Wang Y, Teichtahl AJ, Cicuttini FM. Osteoarthritis year in review 2015: Imaging. *Osteoarthritis and Cartilage*. 2016;24(1):49-57. doi:10.1016/j.joca.2015.07.027
- Blagojevic M, Jinks C, Jeffery A, et al. Risk factors for onset of osteoarthritis of the knee in older adults: a systematic review and meta-analysis. *Osteoarthritis and Cartilage*. 2010;18(1):24-33. doi:10.1016/j.joca.2009.08.010
- Lawrence RC, Felson DT, Helmick CG, et al. Estimates of the prevalence of arthritis and other rheumatic conditions in the United States. Part II. *Arthritis and Rheumatism*. 2008;58(1):26-35. doi:10.1002/art.23176
- Kolasinski SL, Neogi T, Hochberg MC, et al. 2019 American College of Rheumatology/Arthritis Foundation Guideline for the Management of Osteoarthritis of the Hand, Hip, and Knee. *Arthritis Rheumatol*. 2020;72(2):220-233. doi:10.1002/art.41142
- Kellgren JH, Lawrence JS. Osteo-arthrosis and disk degeneration in an urban population. *Annals of the rheumatic diseases*. 1958;17(4):388-397. doi:10.1136/ard.17.4.388
- Sellam J, Berenbaum F. The role of synovitis in pathophysiology and clinical symptoms of osteoarthritis. *Nat Rev Rheumatol*. 2010;6(11):625-635. doi:10.1038/nrrheum.2010.159
- McAlindon TE, Bannuru RR, Sullivan MC, et al. OARSI guidelines for the non-surgical management of knee osteoarthritis. *Osteoarthritis Cartilage*. 2014;22(3):363-388. doi:10.1016/j.joca.2014.01.003
- Charlesworth J, Fitzpatrick J, Perera NKP, Orchard J. Osteoarthritis - a systematic review of long-term safety implications for osteoarthritis of the knee. *BMC Musculoskeletal Disorders*. 2019;20(1). doi:10.1186/s12891-019-2525-0
- Schjerning AM, McGettigan P, Gislason G. Cardiovascular effects and safety of (non-aspirin) NSAIDs. *Nature Reviews Cardiology*. 2020;17(9):574-584. doi:10.1038/s41569-020-0366-z
- Conaghan PG, Cook AD, Hamilton JA, et al. Therapeutic options for targeting inflammatory osteoarthritis pain. *Nat Rev Rheumatol*. 2019;15(6):355-363. doi:10.1038/s41584-019-0221-y
- Latourte A, Kloppenburg M, Richette P. Emerging pharmaceutical therapies for osteoarthritis. *Nature Reviews Rheumatology* 2020 16:12. 2020;16(12):673-688. doi:10.1038/s41584-020-00518-6
- Vrouwse JPM, Burggraaf J, Kloppenburg M, et al. Challenges and opportunities of pharmacological interventions for osteoarthritis: A review of current clinical trials and developments. *Osteoarthritis and Cartilage Open*. 2021;3(4):100212. doi:10.1016/j.OCARTO.2021.100212
- Jiang Y, Zhang W, Yin Z, et al. Human cartilage-derived progenitor cells from committed chondrocytes for efficient cartilage repair and regeneration. *Stem Cells Translational Medicine*. 2016;5(6):733-744.
- Medvedeva E V., Grebenik EA, Gornostaeva SN, et al. Repair of damaged articular cartilage: Current approaches and future directions. *International Journal of Molecular Sciences*. 2018;19(8). doi:10.3390/ijms19082366
- Decker RS, Um H Bin, et al. Cell origin, volume and arrangement are drivers of articular cartilage formation, morphogenesis and response to injury in mouse limbs. *Developmental Biology*. 2017;426(1):56-68. doi:10.1016/j.ydbio.2017.04.006
- Schulz KF. Consort 2010 Statement: Updated Guidelines for Reporting Parallel Group Randomized Trials. *Annals of Internal Medicine*. 2010;152(11):726. doi:10.7326/0003-4819-152-11-201006010-00232
- An TW, Boone SL, Boyer MI, et al. Effect of ice on pain after corticosteroid injection in the hand and wrist: A randomized controlled trial. *Journal of Hand Surgery: European Volume*. 2016;41(9):984-989. doi:10.1177/1753193416657678
- Fawi HMT, Hossain M, Matthews TJW. The incidence of flare reaction and short-term outcome following steroid injection in the shoulder. *Shoulder and Elbow*. 2017;9(3):188-194. doi:10.1177/1758573217693808

Table 1 Patient baseline characteristics

	Placebo (n=14)	LRX712 0.5mg (n=4)	LRX712 2.5 mg (n=4)	LRX712 7.5 mg (n=4)	LRX712 15 mg (n=4)	LRX712 25 mg (n=4)	LRX712 40 mg (n=4)	LRX712 75 mg (n=4)	Full group (n=42)
Age at inclusion (years), mean (range)	56.1 (30-64)	58.5 (48-66)	59.3 (54-65)	50.0 (43-57)	57.5 (52-62)	60.5 (55-65)	58.8 (41-65)	58.8 (54-64)	57.1 (30-65)
Female n (%)	11 (78.6)	2 (50)	4 (100)	3 (75)	3 (75)	2 (50)	2 (50)	2 (50)	29 (69.0)
Race n (%)									
white	14 (100)	4	3	4	4	3	3 (75)	4 (100)	39 (92.9)
other	0 (0)		1 (25)	0 (0)	0 (0)	1 (25)	1 (25)	0 (0)	3 (7.1)
Height (cm), mean (range)	173.5 (161.4-200.8)	173.88 (169.9-179.2)	167.8 (164.0-173.9)	176.0 (163.5-187.1)	171.2 (167.2-176.1)	173.7 (163.0-184.0)	168.7 (160.6-175.2)	177.6 (167.0-189.0)	172.9 (160.6-200.8)
Weight (kg), mean (range)	73.79 (55.2-98.9)	80.95 (64.9-92.0)	78.25 (73.8-85.7)	80.78 (56.5-110.9)	78.82 (70.0-93.6)	88.1 (70.9-102.6)	75.43 (62.5-87.7)	89.93 (72.9-113.4)	79.1 (55.2-113.4)
BMI (kg/m ²), mean (range)	24.5 (19.6-30.3)	26.7 (22.5-29.9)	27.8 (27.4-28.3)	25.6 (20.0-31.5)	26.9 (23.4-30.2)	29.1 (26.7-33.3)	26.5 (24.2-30.5)	28.2 (25.2-31.7)	26.3 (19.6-33.3)
KL grade of the index knee n, %									
1	4 (29)	2 (50)	3 (75)	0 (0)	0 (0)	2 (50)	1 (25)	0 (0)	12 (29)
2	7 (50)	2 (50)	1 (25)	2 (50)	4 (100)	2 (50)	2 (50)	1 (25)	21 (50)
3	3 (21)	0 (0)	0 (0)	2 (50)	0 (0)		1 (25)	3 (75)	9 (21)

Table 2 Adverse events per treatment group

	Placebo (n=14)	LRX712 0.5mg (n=4)	LRX712 2.5 mg (n=4)	LRX712 7.5 mg (n=4)	LRX712 15 mg (n=4)	LRX712 25 mg (n=4)	LRX712 40 mg (n=4)	LRX712 75 mg (n=4)	Full group (n=42)
Number of patients reporting an AE, n (%)	7 (50)	4 (100)	4 (100)	4 (100)	3 (75)	4 (100)	4 (100)	4 (100)	34 (81.0)
Patients reporting an AE of mild severity n (%)	7 (50)	4 (100)	4 (100)	4 (100)	3 (75)	4 (100)	4 (100)	4 (100)	34 (81.0)
Patients reporting an AE of moderate severity n (%)	0 (0)	0 (0)	0 (0)	0 (0)	0 (0)	0 (0)	3 (75)*	3 (75)*	6 (14.3)
Patients reporting an AE of severe severity, SAEs or deaths n (%)	0 (0)	0 (0)	0 (0)	0 (0)	0 (0)	0 (0)	0 (0)	0 (0)	0 (0)
Injection site conditions	3	4	4	3	2	2	8	7	33
Injection site (joint) pain	1	0	3	1	0	2	3	3	13
Injection site ROM impaired	0	0	0	0	1	0	3	2	6
Injection site swelling	1	0	1	1	0	0	2	1	6
Injection site reactions otherwise ^a	1	4	0	1	1	0	0	1	8
Musculoskeletal symptoms other than the target joint	3	0	1	0	1	5	0	0	10
Back pain	0	2	0	1	0	2	1	2	8
Gastro-intestinal AEs	0	0	3	1	2	1	0	0	7
Cardiovascular symptoms otherwise	1	0	0	2	0	2	2	0	7
Dermatological AEs	3	1	0	0	2	0	1	0	7
Respiratory tract AEs	1	3	0	1	0	0	1	1	7
Headache	1	0	1	1	1	0	1	1	6
Psychiatric AEs	2	0	0	0	1	1	0	0	4
Endocrine AEs	1	0	1	0	0	0	0	2	4
Urinary tract AEs	1	0	0	0	0	0	0	1	2

AE adverse event, SAE serious adverse event, ROM range of motion / *AEs of moderate severity concerned injection site pain (in 3 patients of the 40mg group, 1 in the 75mg group), injection site movement impairment and hyperventilation (1 of each in the 75mg group) / 1 Injection site reactions otherwise include: joint discomfort (2 AEs), general injection site reaction, injection site dullness, injection site warmth and hematoma (all 1 AE).

Table 3 Summary of plasma pharmacokinetics of LRX712 per dose level

	LRX712 0.5 mg (n=4)	LRX712 2.5 mg (n=4)	LRX712 7.5 mg (n=4)	LRX712 15 mg (n=4)	LRX712 25 mg (n=4)	LRX712 40 mg (n=4)	LRX712 75 mg (n=4)
C_{MAX} (ng/mL) Mean \pm SD (CV%)	0.413 \pm 0.329 (79.8)	2.27 \pm 1.77 (78.1)	8.79 \pm 6.24 (71.0)	3.85 \pm 4.13 (107.4)	18.0 \pm 4.25 (23.7)	17.6 \pm 9.50 (54.1)	19.3 \pm 11.7 (60.9)
T_{MAX} (hr) Median (range)	4.00 (4.00-4.00)	6.5 (4.00-24.0)	4.00 (4.00-4.00)	24.0 (4.0-24.0)	18.1 (8.0-24.3)	24.0 (8.0-24.0)	14.0 (4.0-24.0)
AUC_{LAST} (hr*ng/mL) Mean \pm SD (CV%)	737 \pm 3.87 (52.5)	675 \pm 34.5 (51.1)	172 \pm 116 (67.7)	335 \pm 78.8 (23.5)	856 \pm 282 (32.9)	1100 \pm 393 (35.6)	1420 \pm 840 (59.3)
AUC_{INF} (hr*ng/mL) Mean \pm SD (CV%)	8.32 \pm 3.82 (45.9)	69.4 \pm 34.4 (49.5)	174 \pm 116 (66.4)	405 \pm 111 (27.4)	858 \pm 281 (32.7)	1270 \pm 585 (46.1)	1650 \pm 1090 (66.1)
$T_{1/2}$ (hr) Mean \pm SD (CV%)	23.2 \pm 2.58 (11.1)	42.4 \pm 31.4 (74.2)	27.4 \pm 3.36 (12.3)	239 \pm 160 (66.8)	32.8 \pm 7.15 (21.8)	48.7 \pm 31.1 (64.0)	179 \pm 162 (90.4)
V_z/F (L) Mean \pm SD (CV%)	2430 \pm 1280 (52.5)	2750 \pm 2290 (83.4)	2210 \pm 1100 (49.6)	12100 \pm 7960 (65.6)	1530 \pm 735 (48.1)	2110 \pm 443 (21.0)	15000 \pm 18100 (120.6)
CL/F (L/hr) \pm SD (CV%)	70.3 \pm 30.9 (43.9)	46.7 \pm 30.2 (64.7)	58.5 \pm 33.8 (57.8)	39.1 \pm 9.98 (25.5)	31.5 \pm 9.88 (31.3)	35.3 \pm 16.3 (46.1)	61.1 \pm 33.4 (54.7)

Table 4 Summary of plasma pharmacokinetics of MAE344 per dose level

	LRX712 0.5 mg (n=4)	LRX712 2.5 mg (n=4)	LRX712 7.5 mg (n=4)	LRX712 15 mg (n=4)	LRX712 25 mg (n=4)	LRX712 40 mg (n=4)	LRX712 75 mg (n=4)
C_{MAX} (ng/mL) Mean \pm SD (CV%)	2.43 \pm 1.65 (68.0)	10.2 \pm 5.55 (54.2)	47.6 \pm 20.8 (43.8)	45.4 \pm 51.9 (114.4)	148 \pm 25.6 (17.3)	199 \pm 122 (61.1)	161 \pm 85.9 (53.5)
T_{MAX} (hr) Median (range)	24.0 (8.0-24.0)	30.0 (8.0-36.0)	24.0 (12.0-24.0)	48 (24.0-54.0)	24.2 (24.0-30.0)	24 (24.0-48.0)	36 (24.0-72.0)
AUC_{LAST} (hr*ng/mL) Mean \pm SD (CV%)	137 \pm 58.0 (42.4)	767 \pm 359 (46.8)	2950 \pm 1390 (47.2)	5550 \pm 826 (14.9)	10600 \pm 1950 (18.3)	16900 \pm 5750 (33.9)	21000 \pm 11700 (55.7)
AUC_{INF} (hr*ng/mL) Mean \pm SD (CV%)	147 \pm 61.5 (41.9)	791 \pm 428 (54.1)	2960 \pm 1390 (47)	6790 \pm 1440 (21.2)	10600 \pm 1950 (18.4)	21300 \pm 2650 (12.5)	23900 \pm 14500 (60.8)
$T_{1/2}$ (hr) Mean \pm SD (CV%)	37.4 \pm 10.9 (29)	29.6 \pm 3.08 (10.4)	33.3 \pm 1.08 (3.2)	245 \pm 155 (63.3)	37.6 \pm 9.14 (24.3)	46.0 \pm 21.1 (45.9)	159 \pm 136 (85.2)

Figure 1 CONSORT 2010 flow chart of screened and included patients¹⁷

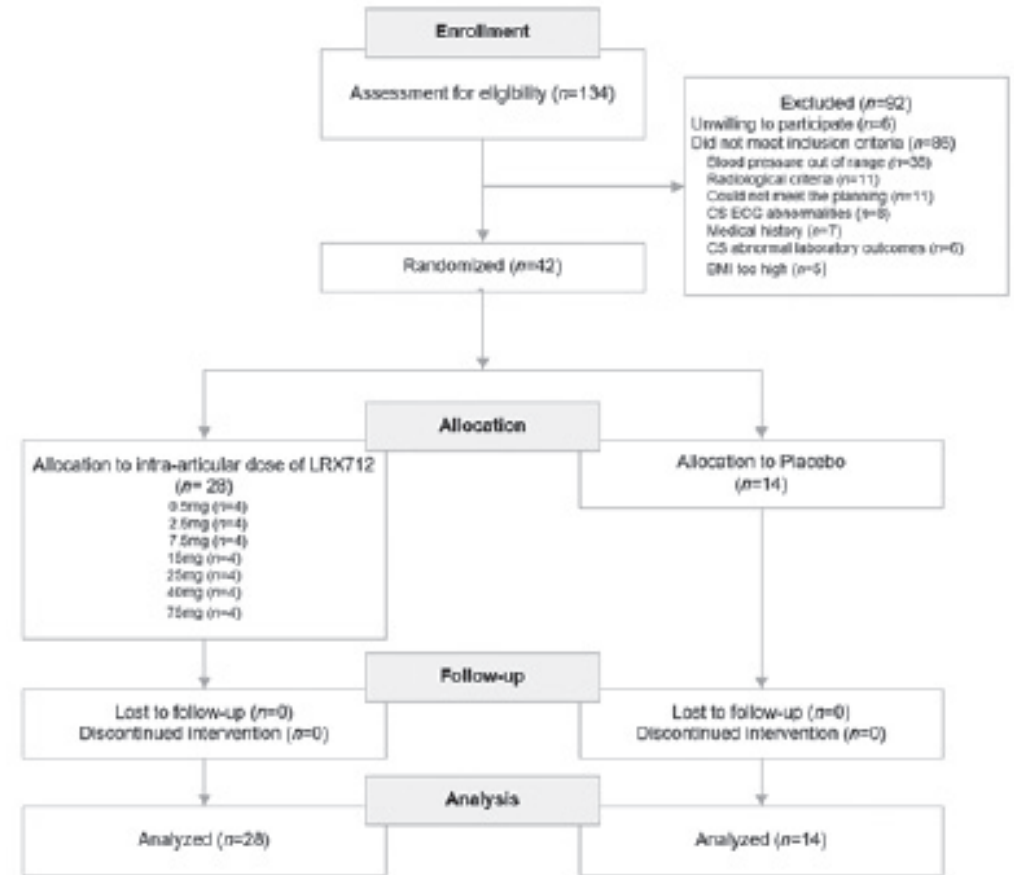

ECG electrocardiography, BMI Body mass index, CS clinically significant.

Figure 2 PK graphs per cohort, with individual PK outcomes

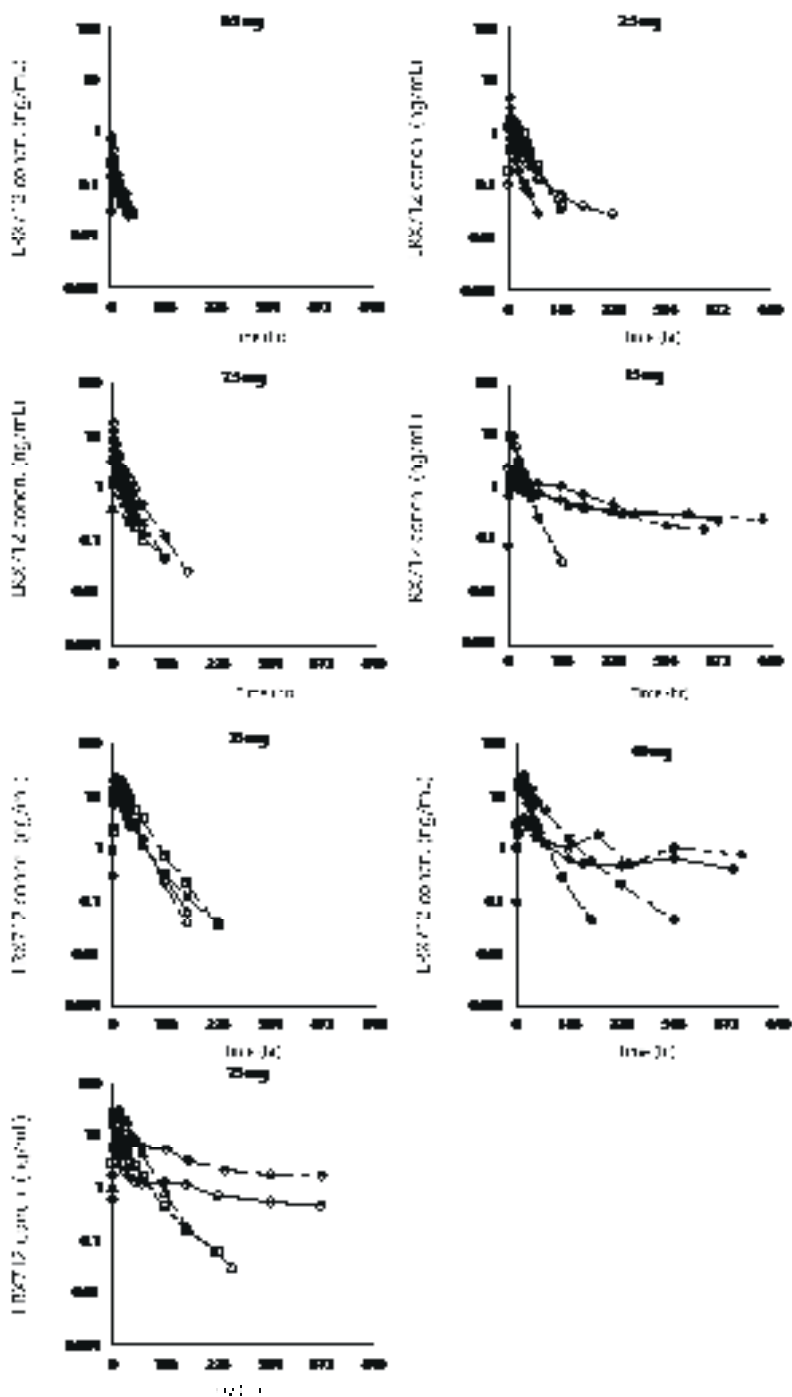

Administration of an adeno-associated viral vector expressing interferon- β in patients with inflammatory hand arthritis, results of a phase I/II study

J.P.M. Vrouwe^{1,2}, J.J.M. Meulenberg³, N.B. Klarenbeek^{1,4}, A. Navas Cañete⁵, M. Reijnierse⁵, G. Ruitkamp³, L. Bevaart³, R.J. Lamers³, M Kloppenburg⁶, R.G.H.H. Nelissen⁷, T.W.J. Huizinga⁸, J. Burggraaf^{1,4,8}, I.M.C. Kamerling^{1,9}

Osteoarthritis Cartilage. 2021 Oct 6;S1063-4584(21)00930-4. doi: 10.1016/j.joca.2021.09.013.

-
- 1 Centre for Human Drug Research, Leiden, NL
 - 2 Leiden University Medical Center (LUMC) – Department of Medical Oncology
 - 3 Arthrogen B.V., Amsterdam, NL
 - 4 Leiden University Medical Center, NL – Department of Internal Medicine
 - 5 Leiden University Medical Center, NL – Department of Radiology
 - 6 Leiden University Medical Center, NL – Department of Rheumatology
 - 7 Leiden University Medical Center, NL – Department of Orthopaedics
 - 8 Leiden Academic Centre for Drug Research, Leiden, NL
 - 9 Leiden University Medical Center, NL – Department of Infectious diseases
-

ABSTRACT

OBJECTIVE Inflammatory hand arthritis (IHA) results in impaired function. Local gene therapy with ART-IO2, a recombinant adeno-associated viral (AAV) serotype 5 vector expressing interferon (IFN)- β , under the transcriptional control of nuclear factor κ -B responsive promoter, was preclinically shown to have favorable effects. This study aimed to investigate the safety and tolerability of local gene therapy with ART-IO2 in patients with IHA.

METHODS In this first-in-human, dose-escalating, cohort study, 12 IHA patients were to receive a single intra-articular (IA) injection of ART-IO2 ranging 0.3×10^{12} - 1.2×10^{13} genome copies in an affected hand joint. Adverse events (AEs), routine safety laboratory and the clinical course of disease were periodically evaluated. Baseline- and follow-up contrast enhanced magnetic resonance images (MRIS), shedding of viral vectors in bodily fluids, and AAV5 and IFN- β immune responses were evaluated. A data review committee provided safety recommendations.

RESULTS Four patients were enrolled. Long-lasting local AEs were observed in 3 patients upon IA injection of ART-IO2. The AEs were moderate and could be treated conservatively. Given the duration of the AEs and their possible or probable relation to ART-IO2, no additional patients were enrolled. No systemic treatment emergent AEs were observed. The MRIS reflected the AEs by (peri)arthritis. No T-cell response against AAV5 or IFN- β , nor IFN- β antibodies could be detected. Neutralizing antibody titers against AAV5 raised post-dose.

CONCLUSIONS Single IA doses of 0.6×10^{12} or 1.2×10^{12} ART-IO2 vector genomes were administered without systemic side effects or serious AEs. However, local tolerability was insufficient for continuation.

REGISTRATION NCT02727764

Introduction

Osteoarthritis (OA) and rheumatoid arthritis (RA) can both manifest with inflammatory hand arthritis (IHA) and cause considerable disability.^{1,2} Although pathophysiology of OA and RA differ, inflammation of the synovium plays a pivotal role in both.³⁻⁶ This inflammation occurs in exacerbations and leads to destruction of joint tissues, joint pain and impaired function.⁷ Currently, no registered therapy halts the deterioration of joints caused by OA.⁸ For RA, systemic disease modifying anti-rheumatic drugs are available, but some patients respond poorly to these.⁹ The lack of full efficacy of pharmacological interventions may be due to ineffective interference with pathophysiological pathways, poor penetration into the synovium, or timing of the drug-availability in relation to the inflammatory status within the joint.¹⁰ Hence, inflammation driven, intra-articular (IA) treatment may take preference over systemic treatment in mono- or oligo-arthritis.

Interferon (IFN)- β has anti-inflammatory properties, such as the inhibition of tumor necrosis factor and interleukin- 1β production by macrophages in the inflamed synovium.^{11,12} IFN- β has been administered in multiple clinical trials, confirming its safety after intra-muscular, and subcutaneous injection.¹²⁻¹⁴ Efficacy studies with subcutaneously administered IFN- β in arthritic patients showed ambiguous results: In a small study, patient reported- and histological efficacy was shown.¹³ In a larger study, these effects could not be confirmed, which was hypothesized to be due to low local exposure of the inflamed joint and the short half-life of IFN- β .¹² Novel approaches, enabling local and inducible expression of IFN- β in case of an exacerbation may provide efficacy.

Such an approach, a recombinant adeno-associated virus (AAV) vector expressing IFN- β under the transcriptional control of a promoter responsive to the pro-inflammatory nuclear factor κ B (NF- κ B), ART-IO2, was investigated in this study. The IFN- β expression cassette of ART-IO2 is flanked by two AAV2 derived inverted terminal repeats and is packaged in the capsid of AAV5. NF- κ B has been described to be upregulated in both RA and OA.^{15,16} Recombinant AAV vectors are replication-deficient vectors which have been shown to be safe in multiple clinical trials.¹⁷⁻²⁰ The capsid of AAV5 was chosen because of its efficient transduction in synovial tissue and the low incidence of pre-existing neutralizing antibodies for AAV5.²¹⁻²⁴ As such, ART-IO2 was designed to produce an anti-inflammatory compound (IFN- β) locally in the joint in periods of inflammation. In *in vitro* studies with

fibroblast-like synoviocytes from RA- and OA patients, decreased synovial inflammation was observed. Pre-clinical studies for biodistribution, safety and initial efficacy in animal models for arthritis in rats and rhesus monkeys showed that ART-IO2 was well tolerated and decreased synovial inflammation due to expression of IFN- β .²⁵⁻²⁷ Altogether, these results warranted evaluation of ART-IO2 in RA and OA patients. Here we describe the first-in-human study in which the safety and tolerability of a single IA administration of ART-IO2 was investigated in patients with IHA.

Methods

STUDY DESIGN

This was a single center, open label, first-in-human, dose escalating study to investigate the safety and tolerability of a single, IA injection of ART-IO2 in up to 12 IHA patients. The study was conducted at the Centre for Human Drug Research (CHDR) in Leiden, the Netherlands. Patient enrollment was in 3 cohorts (3:3:6 patients). The IA doses for cohort I (patients 1-3) were 1.2×10^{12} , 0.6×10^{12} , or 0.3×10^{12} vector genomes (VG) for the carpometacarpal (CMC) and metacarpophalangeal (MCP)-, proximal interphalangeal (PIP)- and distal interphalangeal (DIP)- joints, respectively. A ten-fold increase in dose was planned for cohort II (patients 4-6). Cohort III (patients 7-12) was planned to receive the highest tolerated dose, as determined from the safety data from the previous cohorts. The injection volumes were 500 μ L, 250 μ L and 125 μ L for the CMC/MCP, PIP and DIP joints, respectively. The injections were performed in a sterile environment, under ultrasound-guidance, by board-certified musculoskeletal radiologists (MR or ANC with respectively 24 and 13 years of experience). Patients were followed for 24 weeks after study drug administration; long-term safety follow-up is conducted by yearly telephone calls up to 5 years.

The study was approved by the Central Committee on Research Involving Human Subjects (CCMO), The Hague, The Netherlands, and was registered in the clinicaltrials.gov registry (NCT02727764). All patients provided written informed consent prior to participation. Study related procedures were conducted in accordance with the Declaration of Helsinki and the Dutch Act regarding Medical Research Involving Human Subjects. An environmental permit on 'deliberate release into the environment' (according to the directive 2001/18/EC of the European Parliament and of the Council) had been granted prior to the study (License: GGOIM-MV16-001). An independent data review committee (DRC) was installed to review the safety data after

each cohort and to give recommendations for dose escalation and stopping decisions (supplementary methods 1).

INVESTIGATIONAL PRODUCT

Construction of the ART-IO2 vector has been described previously.²⁶ ART-IO2 was produced using polyethylenimine (PEI^{PRO}TM) mediated transient transfection of HEK293T/17 cells with pART-IO2 vector plasmid and PDP5-KAN3 helper/packaging plasmid, a derivative of PDP5 with the ampicillin resistance gene replaced by the kanamycin resistance gene. ART-IO2 was purified in steps including affinity chromatography, ion exchange chromatography and filtration.^{28,29} ART-IO2 was manufactured in accordance with Good Manufacturing Practices. QC testing was performed according to Ph.Eur.chapter "5.14". The ratio of vector genomes:AAV-particles of ART-IO2 was 1:6.6. Starting doses were selected based on pre-clinical results of ART-IO2 effectivity- and toxicity studies,^{21,26} and RAAV vectors in other clinical trials.^{30,31} Injection volumes were based on current clinical practice with IA injections.

PARTICIPANTS

Patients with an inflammatory arthritis of the CMC, MCP, PIP or DIP joints and an indication to undergo surgical intervention of the target joint, were eligible. The indication for surgical intervention and diagnosis of OA or RA had to be established by a treating physician and inflammation was confirmed on Magnetic Resonance Imaging (MRI). At screening, baseline characteristics and medical history were collected, physical examination, routine safety laboratory and urinalysis were performed, and further in- and exclusion criteria were assessed. Exclusion criteria included presence of neutralizing antibodies against AAV5 and/or IFN- β , previous treatment with an AAV5 and a poor functional status. Patients could remain on their current medication and stop or start medication as appropriate. Full in- and exclusion criteria are provided in supplementary methods 2.

SAFETY

Patients remained in the clinic for at least 4 hours to observe the initial reaction to the ART-IO2 administration. Clinical follow-up visits took place at 24 hours, and 1, 2, 4, 8, 12, 16, 20 and 24 weeks after administration. Safety was assessed by physical examination, vital signs, 12-lead electrocardiography, safety laboratory evaluation, urinalysis, and the presence of- and changes

in adverse events (AEs) according to the Rheumatology Common Toxicity Criteria (R-CTCAE).³²

After 24 weeks, patients proceeded into a 5-year follow-up with annual phone calls to monitor long-term safety, consisting of a standardized questionnaire including the occurrence of hospitalization or surgical intervention, potentially treatment related events and relevant oncologic, infectious, neurological, hematological or immunological events.

FUNCTIONAL ASSESSMENTS

The functionality of the injected joint was monitored by assessment according to the Composite Change Index (CCI) at each follow-up visit.^{33,34} The CCI score is calculated from six outcomes: a physician completed part, including assessment of function, joint tenderness, swelling and efficacy, all on a 4-point scale, and a patient completed part including a visual analogue score for pain (0-10) and efficacy (4-point scale). Based on changes from baseline, a score between 0 and 10 was calculated at follow-up. Scores <5 were defined as no effect or deterioration, scores ≥5 were defined as successful treatment. The CCI scoring and calculation methods are given in supplementary methods 3. In addition, flexion and extension range of motion were measured in degrees, for the MCP, PIP and DIP joints, using a goniometer.

MRI

The level of arthritis of the target joint was evaluated using MRI scans at screening, 12, and 24 weeks after study drug administration. Images were obtained by static and dynamic, contrast enhanced MRIs from the CMC joints to the fingers distally, using a 3T MR scanner (Philips, Eindhoven, The Netherlands), and dedicated small extremity MR coil. All MRI scans were made in the Leiden University Medical Center (CHDR), Leiden, The Netherlands. The following sequences were acquired before contrast injection: coronal and axial T1-weighted Turbo Spin Echo (TSE) sequence (repetition time/echo time TR/TE 623/18ms) and coronal T2 Dixon (TR/TE 2500/60ms) and axial T2 Dixon (3286/60ms). After intravenous injection of gadolinium contrast (gadoteric acid, Guerbet, Paris, France, standard dose of 0.1mmol/kg), a dynamic contrast-enhanced (DCE-MRI) sequence was performed, using 8 slices.

After DCE-MRI sequence the following sequences were obtained: T1-weighted TSE sequence with frequency selective fat saturation in the coronal and axial plane (TR/TE 727/18ms). The field-of-view was 130mm. Coronal

sequences had 20 slices with a slice thickness of 2mm, no slice gap. The axial sequences had 50 slices, with thickness of 2.5mm, no slice gap.

The target joints were assessed qualitatively and semi-quantitatively. A musculoskeletal radiologist (MR or ANC) assessed the scans for quality and performed a qualitative assessment of the target joint, in a narrative report. Semi-quantitative scoring was done by experienced readers in these assessments (YD and FK). Reported outcomes were based on categories of validated MRI scoring systems for hand OA and RA, and included synovitis, bone marrow edema (RA) or bone marrow lesions (OA) and bone erosions (RA) or subchondral bone defects/erosive damage (OA).³⁵⁻³⁷

IMMUNOLOGY

The humoral and cellular immune responses against AAV5 and IFN-β, as well as the presence of IFN-β, were measured at set time points during the study using validated assays (Table 1).

The presence of AAV5-neutralizing antibodies (titers >15) was measured using an inhibition of transduction assay. In this assay, the residual expression of luciferase was measured in HEK293T cells after transduction with an AAV5 vector pre-incubated with the test serum. Luciferase was quantified using a VictorX microplate reader, PerkinElmer (Waltham, MA, USA) (undiluted to 1:405 diluted). Binding antibodies against AAV5 were determined by ELISA using the BioTek PowerWaveXS spectrophotometer (Winooski, VT, USA) (dilutions of 1:100 to 1:24300).

Binding antibodies against IFN-β were measured using a bridging assay format (MesoScale Discovery platform, Rockville, MD, USA). Serum samples were pre-incubated with biotin labeled and SULFO-TAG™ labeled IFN-β, and subsequently transferred to a microtiter plate coated with Streptavidin and incubated for 1hr at room temperature. After washing, the plates were stained with 2× Read buffer T and quantified using the MESO QuickPlex SQ120 imager. Samples were tested 1:10 diluted in the screening assay, and in case they were positive, further two-fold serial dilutions were made to determine the titer. Neutralizing antibodies against IFN-β were analyzed in the iLite IFN-β neutralizing antibody assay (SVAR, Malmö, Sweden), but only if binding antibodies were positive.

T-cell responses against IFN-β and AAV5 were tested using peripheral blood mononuclear cells (PBMCs), in Interferon-γ ELISpot assays (ImmunoSpot® S6 CORE, Shaker heights, OH, USA), using three peptide pools of overlapping 15-mer peptides of IFN-β and AAV5.

The plasma protein IFN- β concentrations were measured, using a human IFN- β serum ELISA assay with a lower limit of quantification of 2.3-18.8 pg/mL (VeriKine-HS™, PBL Assay science, Piscataway, NJ, USA).

VIRAL SHEDDING

Shedding of ART-IO2 was measured using quantitative polymerase chain reaction (QPCR) in blood, saliva, urine and feces (QuantStudio 7 real-time PCR, applied Biosystems, Foster City, CA, USA). The Limit of detection was 15-67 copies/ μ g DNA in blood, 86 copies/mL in saliva and urine, and 15 copies/ μ g DNA in feces. For each bodily fluid of each patient the viral shedding was analyzed up to three consecutive negative samples. The synovial fluid and tissue would be analyzed for transduction of ART-IO2 in case tissue samples were available.

STATISTICS

As this was an exploratory phase I-II study, there was no formal power calculation; outcomes are presented in a descriptive manner.

Results

DEMOGRAPHICS AND BASELINE CHARACTERISTICS

Figure 1 contains a flow diagram for the patients in the study. Four patients were included in the trial, their baseline characteristics are presented in Table 2. The three patients of cohort I received the starting dose, i.e. 0.6×10^{12} VG/PIP joint (patient 1) and 1.2×10^{12} VG/CMC joint (patients 2 and 3). Upon review of the safety data of cohort I by the investigator and the DRC, and approval by the ethics committee, cohort II was started with the same (low) dose. Thus, patient 4 received 0.6×10^{12} VG in the PIP joint. An additional DRC meeting was scheduled as the fourth patient developed injection site symptoms. The DRC advised against further study drug administrations and therefore no additional patients were enrolled. All four included participants have completed the clinical follow-up, and the follow-up phone calls up to 2 years post-dose.

SAFETY

During- and immediately after administration, one patient experienced injection site pain. This AE resolved immediately and spontaneously. At the visit 24hrs after injection, no AEs were observed. Three of the four patients

(patients 2,3 and 4) developed injection site reactions 4 to 12 days after study drug administration. The symptoms included increased joint tenderness, diminished grip strength and swelling, and were clinically diagnosed as tenosynovitis. These symptoms lasted for 5 weeks to 4 months and had a fluctuating course (patient 2), or gradually decreased over time (patients 3 and 4). The symptoms were treated with over-the-counter analgesics and instructions to restrict movement with- or without orthoses. These AEs were assessed to be R-CTCAE grade 2 (moderate) in severity and considered possibly or probably related to the injection of ART-IO2. None of the patients experienced treatment-emergent events apart from these local AEs. Although the injection site reaction related to the administration of ART-IO2 persisted for 5 weeks to 4 months, it posed no major health problem nor chronic impairment. There were no abnormalities, in safety measures, or signs of infection. At the one-year follow-up, all patients reported their status to be similar (patients 2, 3 and 4) to the status at baseline or better (patient 1). No treatment emergent AEs were reported by the patients at the telephone follow-up.

FUNCTIONAL ASSESSMENTS

In patient 1, improvement compared to baseline, reflected by a calculated CCI score ≥ 5 , was demonstrated at all visits except for the visit in weeks 4 and 8. The calculated CCI scores of the other three patients were mostly < 5 , indicating no improvement compared to baseline, throughout the study. The range of motion was not affected by the injection of ART-IO2 (data not shown).

MRI

A full overview of the quantitative outcomes is given in Table 3. In the qualitative assessments, the synovitis and peri-arthritis of the target joint in patient 1 slightly improved after ART-IO2 injection compared to baseline, this was not reflected in the quantitative scores: Synovitis remained stable and bone marrow edema and bone erosions remained absent from baseline throughout the study.

In the qualitative assessment of patient 2, peri-arthritis was reported at week 12, which had recovered by week 24. The synovitis scores remained unchanged during the study. New bone marrow lesions had developed in week 12, which had not fully recovered at 24-weeks. Subchondral bone defects remained stable.

The MRI of patient 3 showed increased synovitis (baseline grade 1, week 12 grade 3) and new bone marrow lesions in week 12 (baseline grade 0, week 12 grade 3). Neither had fully recovered at week 24. These outcomes were reflected in the qualitative assessment: peri-arthritis was present at week 12 and had slightly improved at week 24.

Patient 4 had an additional MRI in week 4, because of the observed AEs. The MRI after 4 weeks (Figure 2B), showed a strong increase of the synovitis (baseline grade 1, week 4 grade 3) and peri-arthritis (qualitative assessment) bone marrow lesions and erosive damage remained unchanged compared to baseline (grade 1). The synovitis had returned to the baseline situation at week 24 (Figure 2D).

IMMUNOLOGY AND SYSTEMIC IFN- β PROTEIN

A full overview of the immunology outcomes is given in Table 4. Before injection, serum sample titers for patients 1, 2, and 3 were negative (<1:100) for total binding antibodies against AAV5 as measured by ELISA, and low for patient 4 (1:193). For all four patients, titers raised after injection of ART-IO2 to >1:17,000. Neutralizing antibodies were analyzed at screening using an AAV5 inhibition of transduction assay to exclude patients with titers >1:15 to avoid inhibition of ART-IO2 transduction. The neutralizing antibody titers in the four patients enrolled in this study ranged between 1:1 to <1:8 before injection. The titers increased to >1:405 at week 4 after injection.

Local administration of ART-IO2 did not result in a detectable increase of IFN- β in the circulation. Plasma samples from all four patients collected before and after injection of ART-IO2 were negative, i.e. below the lower limit of detection of 2.3-18.8 pg/mL (Table 4).

Serum samples from all four patients collected before and after injection of ART-IO2 were negative for IFN- β binding antibodies. Therefore, IFN- β neutralizing antibody assays were not performed. T-cell responses against IFN- β and AAV5 did not show a change from baseline.

SHEDDING

Peak levels of ART-IO2 vector DNA in blood were observed at one day after injection and subsequently decreased. All blood samples were negative at four weeks after injection. A full overview is included in Table 4. Vector DNA was detected in saliva of three patients one day after injection, and all saliva samples were negative from one week after administration onwards. No vector DNA was detectable in urine or feces at any time. None of the patients

opted for surgical intervention during the clinical follow-up period, hence no synovial fluid- or tissue was available for examination.

Discussion

In this phase I-II study, ART-IO2 (rAAV2/5-hIFN- β) was administered intra-articularly in four patients with an inflammatory hand joint mono-arthritis. No significant systemic abnormalities were observed and no serious adverse events occurred. Despite systemic safety, late-onset (4-10 days post-dose) injection site reactions manifested in three patients. Peri-arthritis, the inflammation of the tissues surrounding the joint including tendons (teno-synovitis) and subcutaneous tissue, was seen in three patients. None of the patients opted for a surgical intervention. Although the symptom state of the target joints has reverted to the baseline level, the duration of the symptoms at the injection site and the possible or probable relation to ART-IO2, precluded the enrollment of additional patients in the study.

The exact etiology of the observed AEs is currently unclear; drug might have leaked into the soft tissues after ultrasound guided administration and may have caused the periarticular reaction, but a direct association with the injection procedure seems unlikely because of the late onset of the AEs and their long duration. It seems to be more plausible that the experimental gene product was causative, although this cannot be fully proven with the data of the current study.

A cause of the observed events could be an immune response against the viral vector. We observed an increase in the AAV5 binding- and neutralizing antibodies at 4- and 24 weeks. The plasma T-cell responses against AAV5 did not show a relevant change over time, but a local response cannot be excluded. The observed pattern of immune responses was comparable among patients, regardless of the baseline titers of neutralizing antibodies and adverse events. The observed changes in the AAV5 antibodies were also identified in a non-human primate arthritis model of ART-IO2, in combination with a T-cell response against AAV5. These immune responses did not lead to local or systemic adverse events.²⁶ In a clinical study, in which an AAV2 vector encoding for tumor necrosis factor immunoglobulin Fc (rAAV2-TNFR:Fc) was injected IA in the (knee- ankle, wrist, MCP and elbow) joints of arthritis patients, administration site reactions occurred more commonly after administration of rAAV2-TNFR:Fc than after administration of placebo. These AEs were dose dependent, but no relation was found between the

AEs and pre-existing- or developing antibody titers against AAV2.³⁰ In total, 24 administration site reactions were observed after 191 administrations (12.6%), of which 4 (2.1%) were severe and the investigators chose to treat the patients with steroids in 3 cases (1.6%).³⁰ In two other clinical studies, the increased AAV-antibodies may have caused the observed transient alanine aminotransferase levels increase that were observed after intravenous administration. These signs of hepatocellular toxicity resolved upon administration of a tapering dose of prednisolone.^{20,38,39} Finally, ART-102 dose is based on VG, but the amount of viral particles administered was higher (ratio 1:6.6). If future studies would prove AAV particles to be causative of adverse events, these might be prevented by improved separation of empty- and full particles in production, the development of optimized AAV vectors allowing for lower doses potentially in combination with interventions to reduce immune responses.

Another explanation for the locoregional adverse events, may be IA IFN- β expression. Although IFN- β was chosen for its favorable anti-inflammatory properties in arthritis, it also has pro-inflammatory effects, which may have manifested in this study.⁴⁰ Studies that investigated the effect of IFN- β in arthritic patients, reported an anti-inflammatory effect or no effect at all.^{12,13} However, the different administration routes (subcutaneous vs. IA), formulation and the injection in an inflamed site, might have created an environment in which IFN- β has pro-inflammatory properties.^{12,13}

As synovial samples from the injected joints were not obtained, a correlation between locoregional AEs and IFN- β expression or other local biochemical changes could not be assessed. Although we cannot be certain of the local IFN- β expression in this study, AAV5 induced transgene expression was previously confirmed as of 3 days after IA vector administration in pre-clinical non-human primate studies, without the occurrence of local AEs.^{25,26} In these monkeys, local expression of IFN- β was confirmed, but did not result in elevated systemic IFN- β levels. Thus, the fact that elevated serum IFN- β levels, antibody responses, and T-cell responses against IFN- β were not observed in the patients in this study, does not preclude that IFN- β was expressed in the injected joints.

IA administration of AAV may be the preferred route to establish prolonged local exposure, while avoiding systemic exposure and toxicity. Although samples were lacking to measure the local levels of vector in synovium, the analysis of body fluids confirmed that the vector remained predominantly local. Vector DNA levels were within the limits of quantification only

in blood and feces and solely 1 day after study drug administration. A similar pattern in blood was observed upon IA administration of rAAV2-TNFR:Fc in two other studies.^{30,31} Systemic vector concentrations decreased below the limit of quantification between 4-8 weeks upon administration. These studies observed sustained presence of rAAV2-TNFR:Fc in synovium after IA administration up to 49 weeks after administration in a subset of patients. However, in none of the synovial fluid- or tissue samples, the TNFR protein nor mRNA specific to rAAV2-TNFR:Fc were detected.^{30,31} Thus it may be argued that the efficiency of transduction was insufficient to result in detectable TNFR protein expression in the latter studies. This process could not be confirmed in our study either.

A limitation of this study was the small number of patients that was studied. Furthermore, interpretation of the results is hampered by the erratic course of IHA. We performed regular clinical assessments including MRIs of the target joint and blood sampling up to 24 weeks after study drug administration, as per protocol. It may be considered to further extend the observation period in similar studies, particularly because some of the patients mentioned subjective improvement of the injected joint at the telephone follow-up.

Further research in gene- and cell-therapy approaches is required to find an effective vector-based therapy for IHA. Two AAVs (AAV2 encoding TNFR:Fc and AAV5 expressing IFN- β) have now independently shown to cause (dose dependent) administration site reactions upon IA injection, which should be taken into account with further research in this field. One approach could be to combine IA injection of an AAV based vector with a short-acting anti-inflammatory compound.⁴¹ This approach is successfully applied in AEs seen in systemic AAV therapy.^{20,38,39} Its multifactorial aspect and hiatus in knowledge of OA pathophysiology complicates drug development. Cell-based therapy, based on TGF- β enhancement, has been investigated in phase III trials, but currently, the heterogeneity in cell preparation leads to concerns and a recommendation against their application.^{42,43}

For the first time in humans, we administered rAAV2/5-HIFN- β IA in IHA patients. The vector remained predominantly local, systemic exposure and shedding were negligible. We report adverse reactions at the injection site of which the mechanism is currently not understood. The nature and duration of these reactions ask for further modifications and improvements to AAV based gene therapy approaches to explore its potential to treat inflamed joints in arthritis, while minimizing side effects.

REFERENCES

- Smolen J, Aletaha D, McInnes I. Rheumatoid arthritis. *Lancet (London, England)*. 2016;388(10055):2023-2038. doi:10.1016/S0140-6736(16)30173-8
- Xie F, Kovic B, Jin X, He X, Wang M, Silvestre C. Economic and Humanistic Burden of Osteoarthritis: A Systematic Review of Large Sample Studies. *Pharmacoeconomics*. 2016;34(11):1087-1100. doi:10.1007/s40273-016-0424-x
- Firestein GS. Evolving concepts of rheumatoid arthritis. *Nature*. 2003;423(6937):356-361. doi:10.1038/nature01661
- Siebuhr AS, Bay-Jensen AC, Jordan JM, et al. Inflammation (or synovitis)-driven osteoarthritis: an opportunity for personalized prognosis and treatment? *Scand J Rheumatol*. 2016;45(2):87-98. doi:10.3109/03009742.2015.1060259
- Tak PP, Bresnihan B. The pathogenesis and prevention of joint damage in rheumatoid arthritis: advances from synovial biopsy and tissue analysis. *Arthritis Rheum*. 2000;43(12):2619-2633. doi:10.1002/1529-0131(200012)43:12<2619::aid-arr1>3.0.co;2-v
- Mathiessen A, Conaghan PG. Synovitis in osteoarthritis: current understanding with therapeutic implications. *Arthritis Res Ther*. 2017;19(1):18. doi:10.1186/s13075-017-1229-9
- van Beest S, Damman W, Liu R, Reijnierse M, Rosendaal FR, Kloppenburg M. In finger osteoarthritis, change in synovitis is associated with change in pain on a joint-level; a longitudinal magnetic resonance imaging study. *Osteoarthritis Cartilage*. 2019;27(7):1048-1056. doi:10.1016/j.joca.2019.03.007
- Kroon FP, Rubio R, Schoones JW, Kloppenburg M. Intra-Articular Therapies in the Treatment of Hand Osteoarthritis: A Systematic Literature Review. *Drugs Aging*. 2016;33(2):119-133. doi:10.1007/s40266-015-0330-5
- Becede M, Alasti F, Gessl I, et al. Risk profiling for a refractory course of rheumatoid arthritis. *Semin Arthritis Rheum*. 2019;49(2):211-217. doi:10.1016/j.semarthrit.2019.02.004
- Evans CH, Ghivizzani SC, Robbins PD. Gene Delivery to Joints by Intra-Articular Injection. *Hum Gene Ther*. 2018;29(1):2-14. doi:10.1089/hum.2017.181
- Tak PP. IFN-beta in rheumatoid arthritis. *Front Biosci*. 2004;9:3242-3247. doi:10.2741/1475
- van Holten J, Pavelka K, Vencovsky J, et al. A multicentre, randomised, double blind, placebo controlled phase II study of subcutaneous interferon beta-1a in the treatment of patients with active rheumatoid arthritis. *Ann Rheum Dis*. 2005;64(1):64-69. doi:10.1136/ard.2003.020347
- van Holten J, Plater-Zyberk C, Tak PP. Interferon-beta for treatment of rheumatoid arthritis? *Arthritis Res*. 2002;4(6):346-352. doi:10.1186/ar598
- Calabresi PA, Tranquill LR, Dambrosia JM, et al. Increases in soluble VCAM-1 correlate with a decrease in MRI lesions in multiple sclerosis treated with interferon beta-1b. *Ann Neurol*. 1997;41(5):669-674. doi:10.1002/ana.410410517
- Saito T, Tanaka S. Molecular mechanisms underlying osteoarthritis development: Notch and NF-κB. *Arthritis research & therapy*. 2017;19(1). doi:10.1186/S13075-017-1296-Y
- Brown K, Claudio E, Siebenlist U. The roles of the classical and alternative nuclear factor-κB pathways: potential implications for autoimmunity and rheumatoid arthritis. *Arthritis research & therapy*. 2008;10(4). doi:10.1186/AR2457
- Kotterman MA, Schaffer D v. Engineering adeno-associated viruses for clinical gene therapy. *Nat Rev Genet*. 2014;15(7):445-451. doi:10.1038/nrg3742
- Maguire AM, Simonelli F, Pierce EA, et al. Safety and efficacy of gene transfer for Leber's congenital amaurosis. *N Engl J Med*. 2008;358(21):2240-2248. doi:10.1056/NEJMOA0802315
- Pasi KJ, Rangarajan S, Mitchell N, et al. Multiyear Follow-up of AAV5-hFVIII-SQ Gene Therapy for Hemophilia A. *New England Journal of Medicine*. 2020;382(1):29-40. doi:10.1056/NEJMOA1908490
- Rangarajan S, Walsh L, Lester W, et al. AAV5-Factor VIII Gene Transfer in Severe Hemophilia A. *New England Journal of Medicine*. 2017;377(26):2519-2530. doi:10.1056/NEJMOA1708483
- Adriaansen J, Tas SW, Klarenbeek PL, et al. Enhanced gene transfer to arthritic joints using adeno-associated virus type 5: implications for intra-articular gene therapy. *Ann Rheum Dis*. 2005;64(12):1677-1684. doi:10.1136/ard.2004.035063
- Apparailly F, Khoury M, Vervoordeldonk MJ, et al. Adeno-associated virus pseudotype 5 vector improves gene transfer in arthritic joints. *Hum Gene Ther*. 2005;16(4):426-434. doi:10.1089/hum.2005.16.426
- Boutin S, Monteilhet V, Veron P, et al. Prevalence of serum IgG and neutralizing factors against adeno-associated virus (AAV) types 1, 2, 5, 6, 8, and 9 in the healthy population: implications for gene therapy using AAV vectors. *Hum Gene Ther*. 2010;21(6):704-712. doi:10.1089/hum.2009.182
- Mingozzi F, Chen Y, Edmonson SC, et al. Prevalence and pharmacological modulation of humoral immunity to AAV vectors in gene transfer to synovial tissue. *Gene Ther*. 2013;20(4):417-424. doi:10.1038/gt.2012.55
- Aalbers CJ, Bevaart L, Loiler S, et al. Preclinical Potency and Biodistribution Studies of an AAV 5 Vector Expressing Human Interferon-beta (ART-102) for Local Treatment of Patients with Rheumatoid Arthritis. *PLoS One*. 2015;10(6):e0130612. doi:10.1371/journal.pone.0130612
- Bevaart L, Aalbers CJ, Vierboom MP, et al. Safety, Biodistribution, and Efficacy of an AAV-5 Vector Encoding Human Interferon-Beta (ART-102) Delivered via Intra-Articular Injection in Rhesus Monkeys with Collagen-Induced Arthritis. *Hum Gene Ther Clin Dev*. 2015;26(2):103-112. doi:10.1089/humc.2015.009
- Adriaansen J, Fallaux FJ, de Cortie CJ, Vervoordeldonk MJ, Tak PP. Local delivery of beta interferon using an adeno-associated virus type 5 effectively inhibits adjuvant arthritis in rats. *J Gen Virol*. 2007;88(Pt 6):1717-1721. doi:10.1099/vir.0.82603-0
- Grimm D, Kay M, Kleinschmidt J. Helper virus-free, optically controllable, and two-plasmid-based production of adeno-associated virus vectors of serotypes 1 to 6. *Molecular therapy: the journal of the American Society of Gene Therapy*. 2003;7(6):839-850. doi:10.1016/S1525-0016(03)00095-9
- Grimm D, Kern A, Rittner K, Kleinschmidt J. Novel tools for production and purification of recombinant adenoassociated virus vectors. *Human gene therapy*. 1998;9(18):2745-2760. doi:10.1089/HUM.1998.9.18-2745
- Mease PJ, Wei N, Fudman EJ, et al. Safety, tolerability, and clinical outcomes after intraarticular injection of a recombinant adeno-associated vector containing a tumor necrosis factor antagonist gene: results of a phase 1/2 Study. *J Rheumatol*. 2010;37(4):692-703. doi:10.3899/jrheum.090817
- Mease PJ, Hobbs K, Chalmers A, et al. Local delivery of a recombinant adenoassociated vector containing a tumour necrosis factor alpha antagonist gene in inflammatory arthritis: a phase 1 dose-escalation safety and tolerability study. *Ann Rheum Dis*. 2009;68(8):1247-1254. doi:10.1136/ard.2008.089375
- Woodworth T, Furst DE, Alten R, et al. Standardizing assessment and reporting of adverse effects in rheumatology clinical trials II: the Rheumatology Common Toxicity Criteria v.2.0. *J Rheumatol*. 2007;34(6):1401-1414. http://www.jrheum.org/content/jrheum/34/6/1401.full.pdf
- Aalbers CJ, Gerlag DM, Vervoordeldonk MJ, Tak PP, Landewe RB. Single-joint Assessment for the Evaluation of Intraarticular Treatment: Responsiveness and Discrimination of the Composite Change Index. *J Rheumatol*. 2015;42(9):1672-1676. doi:10.3899/jrheum.140956
- Jahangier ZN, Moolenburgh JD, Jacobs JW, Serdijn H, Bijlsma JW. The effect of radiation synovectomy in patients with persistent arthritis: a prospective study. *Clin Exp Rheumatol*. 2001;19(4):417-424.
- Ostergaard M, Edmonds J, McQueen F, et al. An introduction to the EULAR-OMERACT rheumatoid arthritis MRI reference image atlas. *Ann Rheum Dis*. 2005;64 Suppl 1:i3-7. doi:10.1136/ard.2004.031773
- Haugen IK, Eshed I, Gandjbakhch F, et al. The Longitudinal Reliability and Responsiveness of the OMERACT Hand Osteoarthritis Magnetic Resonance Imaging Scoring System (HOAMRIS). *J Rheumatol*. 2015;42(12):2486-2491. doi:10.3899/jrheum.140983
- Kroon F, Peterfy C, Conaghan P, et al. Atlas for the OMERACT thumb base osteoarthritis MRI scoring system (TOMS). *RMD open*. 2018;4(1). doi:10.1136/RMDOPEN-2017-000583
- Nathwani A, Reiss U, Tuddenham E, et al. Long-term safety and efficacy of factor IX gene therapy in hemophilia B. *The New England journal of medicine*. 2014;371(21):1994-2004. doi:10.1056/NEJMOA1407309
- Miesbach W, Meijer K, Coppens M, et al. Gene therapy with adeno-associated virus vector 5-human factor IX in adults with hemophilia B. *Blood*. 2018;131(9):1022-1031. doi:10.1182/Blood-2017-09-804419
- González-Navajas JM, Lee J, David M, Raz E. Immunomodulatory functions of type I interferons. *Nat Rev Immunol*. 2012;12(2):125-135. doi:10.1038/nri3133
- Aalbers C, Broekstra N, van Geldorp M, et al. Empty Capsids and Macrophage Inhibition/Depletion Increase rAAV Transgene Expression in Joints of Both Healthy and Arthritic Mice. *Human gene therapy*. 2017;28(2):168-178. doi:10.1089/HUM.2016.036
- Kim M, Ha C, In Y, et al. A Multicenter, Double-Blind, Phase III Clinical Trial to Evaluate the Efficacy and Safety of a Cell and Gene Therapy in Knee Osteoarthritis Patients. *Human gene therapy Clinical development*. 2018;29(1):48-59. doi:10.1089/HUMC.2017.249
- Kolasinski SL, Neogi T, Hochberg MC, et al. 2019 American College of Rheumatology/Arthritis Foundation Guideline for the Management of Osteoarthritis of the Hand, Hip, and Knee. *Arthritis Care and Research*. 2020;72(2):220-233. doi:10.1002/art.41142

Table 1 Study design Shaded cells areas indicated which assessments were done at which time point in the study.

Study day	-28 to -1	0				1				
Event Description	Screening - AAV5/IFN-β antibody analysis - In/exclusion criteria - Medical history - Baseline MRI	ART-IO2 administration - Ultrasound-guided injection of the target joint with ART-IO2 - Safety assessments				First follow-up visit Measurements for: - Safety (AES, lab, vitals) - Shedding				
Measurement	Study week	1	2	4	8	12	16	20	24	year 1-5
Safety (AES, vital signs, safety lab)										
IFN-β protein										
AAV5/IFN-β Antibodies										
T-cell response										
Shedding										
Functional assessment										
MRI										
Yearly questionnaire										

Table 2 Patient demographic and baseline characteristics

	Patient 1	Patient 2	Patient 3	Patient 4
Sex	Female	Female	Female	Female
Age at enrollment (years)	51	59	58	65
Weight (kg)	68.7	85.6	63.3	56.3
BMI (kg/m ²)	24.8	28.7	22.8	20.8
Diagnosis	RA	OA	OA	OA
Target joint	PIP III	CMC	CMC	PIP II
MRI synovitis score (0-3)	1	2	1	1
Ethnicity	Caucasian	Caucasian	Caucasian	Caucasian

BMI, body mass index; RA, Rheumatoid Arthritis; OA, Osteoarthritis; PIP, proximal interphalangeal joint; CMC, carpometacarpal joint; MRI, magnetic resonance imaging.

Table 3 Quantitative MRI outcomes Quantitative MRI scores of the target joints. Synovitis was graded 0 to 3, with 0 no synovitis and 3 extensive synovitis. Bone marrow edema (RA) or bone marrow lesions (OA) were graded 0 to 3, with affectedness in increments of 33%. Bone erosions were graded 0 to 10 for the RA patient, with increments of 1, with 0 no bone erosions, and 10 100% of the articular surface affected. Subchondral bone defects (CMC) or erosive damage (PIP) were graded 0-3 for the OA patients (0: none, 1: ≤25%, 2: 25-50%, 3: >50% of bone volume or joint surface affected).

	Subject 1			Subject 2			Subject 3			Subject 4			
	BL	w.12	w.24	BL	w.12	w.24	BL	w.12	w.24	BL	w.4	w.12	w.24
Synovitis (0-3)	1	1	1	2	2	2	1	3	2	1	3	3	1
Bone erosions (0-10)	0	0	0										
Subchondral bone defects/ erosive damage (0-3)				1	1	1	1	1	1	1	1	1	1
Bone marrow edema (0-3)	0	0	0										
Bone marrow lesions (0-3)				1	2	2	0	3	2	1	1	0	0

BL Baseline, w. week.

Table 4 Immuno-assay outcomes

	Pa-tient	pre-dose	d.1	w.1	w.2	w.4	w.8	w.12	w.16	w.24
AAV5-bAb titer Method: ELISA LOQ:100, ULOQ:24300	1	<100	-	-	-	658	-	-	-	18235
	2	<100	-	-	-	19526	-	-	-	>24300
	3	<100	-	-	-	12181	-	-	-	>24300
	4	193	-	-	-	3718	-	-	-	17158
AAV5-nAb titer Method: ELISA LOQ:1, ULOQ:405	1	<1	-	-	-	>405	-	-	-	>405
	2	<1	-	-	-	>405	-	-	-	>405
	3	<1	-	-	-	>405	-	-	-	>405
	4w	8	-	-	-	>405	-	-	-	>405
IFN protein Method: ELISA LOQ 2.3-18.8 pg/mL	1-4	All samples were below the limit of quantification.								
IFN bAb Method: electrochemiluminescence, bridging assay format Screening cut-point: ≥1.4 relative electrochemiluminescence, and confirmatory cut-point: ≥13% displacement.	1-4	<	-	-	-	<	-	-	-	<

(Continuation Table 4)

	Pa-tient	pre-dose	d.1	w.1	w.2	w.4	w.8	w.12	w.16	w.24	
IFN nAb	1-4	As bAb were negative, IFN nAb were not measured.									
T-cell response to AAV5 Method: ELISpot (number of spots/0.3×10 ⁶ PBMC for the 3 peptide pools)	1	19/35/62	-	-	-	19/46/65	38/48/70	44/48/80	28/49/69	15/70/42	
	2	21/30/26	-	-	-	3/5/5	14/23/10	4/4/7	1/19/2	8/10/7	
	3	6/7/17	-	-	-	3/2/4	14/21/29	8/26/34	6/40/3	8/18/16	
	4	31/48/55	-	-	-	33/27/27	54/56/42	2/6/2	40/38/25	36/30/24	
T-cell response to IFN-β Method: ELISpot (number of spots/0.3×10 ⁶ PBMC for the 3 peptide pools)	1	27/16/26	-	-	-	62/39/38	76/38/41	60/36/57	51/27/30	50/25/29	
	2	37/23/26	-	-	-	4/1/2	8/7/8	2/3/6	0/0/0	8/9/24	
	3	5/2/10	-	-	-	1/1/0	10/9/7	7/13/7	7/2/8	3/15/1	
	4	35/52/56	-	-	-	16/17/8	28/14/16	0/1/8	21/25/22	48/42/39	
Shedding - blood (copies/ μg DNA. Method: qPCR LOQ, 50 copies/μg DNA, LOD: 15 copies/μg DNA LOQ and LOD applicable when 400ng DNA were tested	1	<15	9.9 × 101	<15	<15	<15	-	-	-	-	
	2	<15	7.3 × 102	<15	<15	<15	-	-	-	-	
	3	<15	1.9 × 102	<67	<67	<15	<15	<15	-	-	
	4	<15	1.2 × 102	<50	<15	<15	<15	-	-	-	
Shedding - saliva (copies/ml) Method: qPCR LOQ, 290 copies/ml, LOD: 86 copies/ml	1	<	<	<	<	<	-	-	-	-	
	2	<	<	<	<	<	-	-	-	-	
	3	<	<	<	<	<	-	-	-	-	
	4	<	7.8 × 103	<	<	<	-	-	-	-	
Shedding - feces and urine	1-4	All samples were below the limit of detection. Method: qPCR Feces: LOQ: 50 copies/μg DNA, LOD: 15 copies/μg DNA, Urine: LOQ, 290 copies/ml, LOD: 86 copies/ml									

d, day; w, week; bAb, binding antibody; nAb, neutralizing antibody; LOQ, Lower limit of quantification; LOD, lower limit of detection; ULOQ, upper limit of quantification; ELISA, enzyme-linked immune sorbent assay; ELISpot, Enzyme-linked immune absorbent spot; <, below lower limit of detection, or quantification whichever is the lowest indicated; <LOQ, below lower limit of quantification and higher than lower limit of detection; -, not measured, as planned per protocol.

Figure 1 CONSORT-based flow diagram for the enrollment, follow-up and analysis of patients

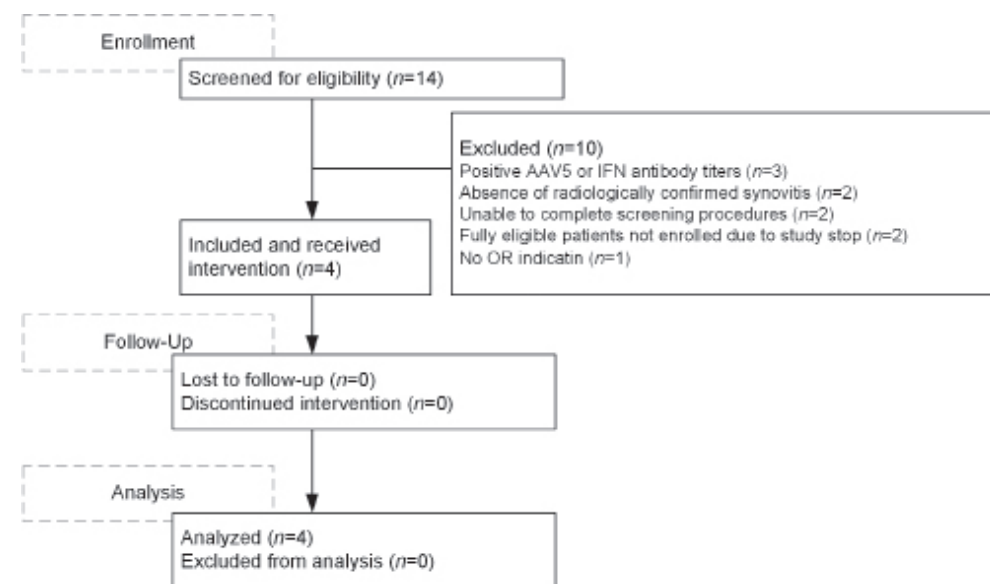
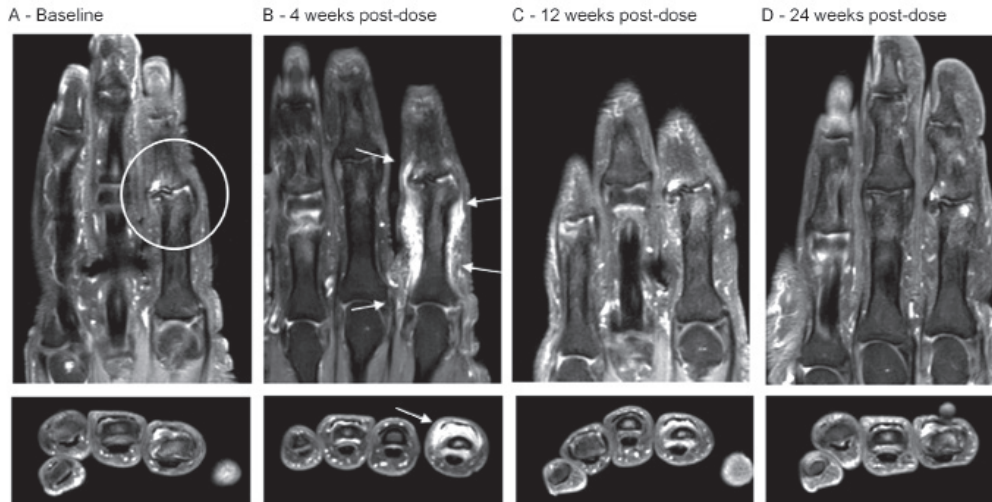

Figure 2 MRIs of patient 4 MRI of the target joint, the proximal interphalangeal joint of the second digit (PIP dig. II) of the left hand, of patient 4, at four different time points during the study. T1-weighted, fat suppressed, Gadolinium-enhanced images, in corresponding coronal- and axial planes shown vertically. Panel A. Baseline scan, showing definite osteoarthritis of PIP II, with minimal synovitis (circle) and an enhancing synovial cyst in the ulnar base of the middle phalanx. The synovitis and cysts are also reflected in the axial plane (bottom pane). Panel B. Scan at 4 weeks after study drug administration, showing substantial increase of swelling of the finger with synovitis in the PIP II joint and peri-arthritis with increased swelling around the extensor tendon and of the soft tissues along the proximal interphalangeal phalanx to the second metacarpophalangeal (MCP II) joint (arrows). The extensive peri-arthritis is also well recognized in the axial plane (bottom pane, arrow). Panel C. Scan at 12 weeks after study drug administration: minimally remaining synovitis, reduction of the peri-arthritis. Panel D. Scan at 24 weeks after study drug administration, image similar compared to baseline (Vitamin capsule as marker in situ).



Pathological conditions of the bones and joints cause great personal and societal burden. This thesis provides new insights for screening, diagnosis, and treatment of a selection of these conditions.

SCREENING

Screening for disease aims to discover those among the apparently well who are in fact suffering from disease. Early detection of disease through screening enables to treat or cure conditions which have already produced pathological change, but which have not so far reached a stage at which medical aid is sought spontaneously.¹ Testicular cancer has a high cure rate and survivors are relatively young.² Therefore, a population of young men is at risk of developing long-term effects of testicular cancer and its treatment for several decades.

The most efficient screening strategy for patients and society is screening those who are at increased risk of having the disease. Despite variations in methods and reporting, a review of available literature regarding the effects of testicular cancer to bone mineral density (**Chapter 2**) confirmed that survivors of testicular cancer are at increased risk to develop osteoporosis. Chemotherapy and/or a hypogonadal state can further aggravate this risk. Previous studies for the separate effects of hypogonadal state and chemotherapy to the bone, also indicated harmful effects to bone health.^{3,4}

The literature review in **Chapter 2** also elucidates the need for more standardized outcomes and complete data availability. The included studies had large variations in their methods, definitions, and results. These variations precluded a direct comparison of results in a meta-analysis, which would have strengthened our outcomes.

DIAGNOSIS

The validity of a diagnostic test depends on its ability to identify those who suffer from a condition, ideally without failing to detect any of them.¹

Calcaneal quantitative ultrasonography (QUS) cannot replace dual energy x-ray absorptiometry (DXA) scans as a diagnostic tool for osteoporosis as defined by the world health organization (WHO) in prostate cancer patients.⁵ In **Chapter 3**, QUS had a high negative predictive value for DXA, but its positive predictive value was low. DXA is used as a gold standard for bone mineral density (bone quantity) measurements and the WHO definition of osteoporosis is an individual DXA outcome in relation to the DXA outcomes of a reference population. Bone quality is a measure of its architecture, geometry

and material properties, thereby bone quality is another important predictor of fragility. DXA is unable to assess these outcomes. Alterations in bone architecture and composition together determine mechanical properties which can quantify fragility (bone's inability to resist fracture.)

It may be questioned which outcome is most relevant: bone quantity and osteoporosis as measured in DXA (often without symptoms), or other parameters such as bone quality and clinical outcomes: fragility fractures and associated morbidity and mortality.⁶ Approximately 40% of fragility fractures occurs in patients with osteoporosis as defined by WHO.⁷ In our study, it appeared that QUS outcomes were lower than DXA outcomes in those who had fragility fractures. QUS may thus gave more clinically relevant outcomes for the prediction of fracture risk than DXA. However, our study was not set-up to investigate this outcome. Studies in different populations found that DXA and QUS had similar predictive value for fractures.⁸⁻¹⁰ The most important drawbacks of QUS are limited precision and calibration, but DXA shares these disadvantages.¹¹ The advantages of QUS, such as lower costs and accessibility, warrant further study of its applicability to further address its fracture-predictive value and to address practical issues related to its introduction in the clinic. Section II focusses on OA, which is commonly diagnosed by assessment of x-rays of the joint, but its suitability as a diagnostic tool for OA may be questioned. X-ray misses early OA changes and is poorly correlated with pain.¹² Synovitis, an early sign of OA, can be captured by magnetic resonance imaging (MRI) or ultrasound. However, MRI is rather expensive even in the Western world, and ultrasound does not capture cartilage- or osseous changes as well as X-Ray. Thereby, there are no established, affordable diagnostic tools available for OA, other than X-ray.

The development of novel compounds for OA could be optimized if precise diagnostic tools were available. Such diagnostic tools may be able to identify subtypes within OA and could be of aid in further decision making. The utility of such subtypes is under investigation.^{13,14}

TREATMENT

Chapters 4 to 7 focus on studies for drug candidates of castration resistant, metastatic prostate cancer and OA. Both indications currently lack disease modifying drugs. In **Chapter 5**, information from a clinical trial registry was collected and reviewed to obtain a representative overview of the standings and developments in osteoarthritis treatment. The compounds under investigation target several pathways which play a role in OA development.

Two first-in-human studies with compounds targeting these pathways described in **Chapters 6 and 7**.

The clinical studies described in **Chapters 4, 6 and 7** all included early phase drug studies in patients from the target patient population, rather than healthy volunteers. Generally, patient recruitment is more difficult, slower and more expensive than recruitment of healthy volunteers. The selection of a patient population in an early stage of clinical development may have several reasons. Outcomes and symptoms of certain diseases can or should not be mimicked in healthy volunteers. Moreover, administration of compounds to healthy volunteers for which the risk analysis is unfavorable and particularly when the risk cannot be managed may not be justified.¹⁵ In those cases, clinical development can be commenced in the patient population. Although more cumbersome, the inclusion of the target population has the potential to give an efficient drug development trajectory. By patient inclusion, a single study can provide valuable insights into safety, tolerability, pharmacokinetics, and preliminary efficacy in the target population, including the relevant variability.¹⁶

The opportunity to investigate efficacy should be considered in study design to maximally exploit the (challenging) fact of patient inclusion in an early-phase clinical trial. Thereby, aims and endpoints must be formulated bearing population-specific results in mind. Indeed, the clinical trials in this thesis brought information that could not have been obtained if healthy volunteers were included. Healthy subjects may: respond differently to liposomes (**Chapter 4**), have different PK of LRX712 after intra-articular administration (**Chapter 6**), or have a different response to ART-102 due to absence of inflammation (**Chapter 7**). Thereby, the target patient populations were the most suitable for these studies.

The formulation of aims and endpoints to acquire new insights, is at least influenced by knowledge, ethics, and financial resources. With the current knowledge and additional resources, the clinical studies described in **Chapters 4, 6 and 7**, could have been further exploited. Ideally, liposomes would have been located *in vivo*, using a radioactive tracer (**Chapter 4**). Such imaging could have confirmed whether the compound reached the targeted osseous metastases. Furthermore, adverse event etiology could have been further clarified if tissue would have been obtained as an integral part of the studies in **Chapters 6 and 7**. Such information from an early phase of clinical development can give guidance to further studies and investments.¹⁶

However, it should be considered that in these cases the study designs and end points should be adaptive and flexible. Restrictively defined analyses and endpoints may hinder exploration of unexpected (adverse) outcomes and are not justified in early phase drug studies. These studies are by definition exploratory and should be designed as such. This is also defined in regulatory documents and described in papers pertaining to this topic.¹⁷⁻¹⁹ Administration site adverse events, as described in **Chapters 6 and 7**, ask for further analysis. Preferably, the required information to analyze setbacks, is obtained as an integral part of a study. In some study protocols, 'adverse events of interest' are defined, for which additional information is then collected. If tissue samples would have been available, the etiology of the adverse events could have been further studied. In the described studies, adverse event etiology was maximally studied by (additional) imaging (**Chapter 7**) and the use of back-up samples (**Chapter 6**).

Future perspectives

SECTION I – BONE IN MALE UROLOGICAL MALIGNANCIES

Screening and treatment of testicular cancer survivors for fracture risk, could prevent fractures and could thereby lower morbidity and mortality. To enable this, osteoporosis screening should be introduced in the urological guidelines. Currently, osteoporosis screening of testicular cancer patients is not mentioned in the European Association of Urology (EAU) guideline for testicular cancer.²⁰ Testicular cancer survivors have an increased risk of hypogonadism, and the Endocrine Society recommends osteoporosis screening for all hypogonadal men, regardless of their medical history.^{21,22} It does seem that these guidelines should align on screening and anti-bone resorptive treatment.

We found that the available literature about bone health in testicular cancer patients is ambiguous. Future studies on this topic should choose their endpoints carefully (e.g. standardize reported clinical endpoints, make individual data available) and should preferably have a long follow-up to enable measurement of late effects.

The negative effect androgen deprivation therapy has on the bones of prostate cancer patients is well established and addressed in guidelines.^{23,24} In clinical practice, however, it does not receive the attention it claims in the guidelines.^{25,26} The education of treating physicians will further enhance awareness and increase screening rates.

The utility of QUS in clinic practice is dependent on several factors. First, more and larger studies are required to evaluate its utility in predicting fragility fractures (rather than BMD). If the value of QUS is confirmed, it must be recognized in guidelines and definitions of organizations such as the WHO and endocrine societies. If both conditions are met, it can be implemented widely, and may contribute to low-threshold screening for osteoporosis, even in remote areas.

With regards to PEG Liposomal treatment of osseous metastases, the first step forward, would be a study for the actual targeting of the liposomes, as was done in mice.²⁷ These studies are ideally executed in patients with osseous metastases, but who are more treatment-naïve than the population included in **Chapter 4**. Such a population could give information about targeting of the liposomes and about efficacy if e.g. concomitant medication is also standardized.

SECTION II – OSTEOARTHRITIS

As repeatedly mentioned, osteoarthritis is a multifactorial, heterogenous disease. The future of OA therapy is likely to be multifactorial too.

There are opportunities in the measurement of endpoints in OA clinical studies. The development of validated set of wet-, digital-, or imaging- biomarkers enables distinction of phenotypes and accurate measurement of disease modifying effects. Both would greatly benefit drug development.

By precisely defining phenotypes, interventions can be developed to target certain subgroups. Chances for successful drug development can be enhanced by targeting certain phenotypes. Potential phenotypes should be based on the causality of OA, and could e.g. be: obesity, trauma-induced OA, hereditary factors, and speed of progression.

Progress in the development of DMOADS is ongoing, and DMOADS will become reality with the increasing knowledge on pathophysiological processes, at least for certain phenotypical subtypes of OA.

Considerations

Testicular cancer patients were found to be at risk of fragility fractures, although the reported studies had their limitations and should be interpreted carefully. QUS was found to be a worthy candidate tool to prescreen prostate cancer patients for osteoporosis and further studies are required to study the ability of QUS to predict fragility fractures in this- and other populations.

In the clinical studies in this thesis, liposomal dexamethasone, LRX712 and ART-102 were administered without systemic adverse reactions. Insights were obtained regarding these compounds' safety and pharmacokinetic profiles. The local tolerability of ART-102 was found insufficient to complete study enrollment.

Meanwhile, we identified opportunities for the optimization of screening processes, and development of compounds targeting osteoporosis and osteoarthritis. The lack of complete- and comparable outcomes amongst clinical studies hindered the compilation of osteoporosis study results, limiting firm conclusions and transition into guidelines for clinical practice. Reporting standards and, especially in case of osteoarthritis, representative biomarkers are to be developed and should be reported in a uniform manner across studies. In the review of ongoing studies for OA medication, we found that new insights into OA pathophysiology already led to targeting pathways as treatment strategies. Further development of this knowledge will aid the development of a DMOAD.

In some areas, such as prostate cancer research, a framework of standard reporting guidelines for researchers is already provided.²⁸ Such guidelines allow a good start to define aims and endpoints. However, guidelines can only temporarily fulfill the reporting requirements in a world of ever-evolving techniques and interdisciplinary research. Investigators are therefore dependent on up-to-date expert knowledge of guidelines and techniques, recent literature, and interdisciplinary connections to define aims, methods and endpoints.

Having mentioned the need for standardized reporting, it must also be addressed that unexpected outcomes can devalue excellently set aims, methods, or endpoints during a study in a matter of a single analysis or the occurrence of an adverse events, as we encountered in the study with ART-102. Therefore, aims and endpoints of (especially early phase) clinical studies should take the options of 'failure' and adverse events into account, and should leave room for anticipation in case of unexpected events. As such, research for screening- diagnostic- and treatments can be further optimized.

REFERENCES

- Wilson JMG, Jungner G. Principles and practice of screening for disease. *Public Health Papers*. 1968;34.
- Sung H, Ferlay J, Siegel RL, et al. Global Cancer Statistics 2020: GLOBOCAN Estimates of Incidence and Mortality Worldwide for 36 Cancers in 185 Countries. *CA: A Cancer Journal for Clinicians*. 2021;71(3):209-249. doi:10.3322/caac.21660
- Adler RA. Cancer treatment-induced bone loss. *Current Opinions of Endocrinology, Diabetes and Obesity*. 2007;14(6):442-445. doi:10.1097/MED.0b013e3282f169b5
- Howell SJ, Radford JA, Adams JE, Shalet SM. The impact of mild Leydig cell dysfunction following cytotoxic chemotherapy on bone mineral density (BMD) and body composition. *Clinical Endocrinology*. 2000;52(5):609-616. doi:10.1046/j.1365-2265.2000.00997.x
- World Health Organization. WHO Scientific Group on the Assessment of Osteoporosis At Primary Health. In: *World Health Summary Meeting Report Brussels, Belgium, 2004*. Vol May. ; 2007:1-13. <http://www.who.int/chp/topics/Osteoporosis.PDF>
- Bliuc D, Nguyen ND, Milch VE, Nguyen T v., Eisman JA, Center JR. Mortality Risk Associated With Low-Trauma Osteoporotic Fracture and Subsequent Fracture in Men and Women. *JAMA*. 2009;301(5):513-521. doi:10.1001/jama.2009.50
- Schuit SCE, van der Klift M, Weel AEAM, et al. Fracture incidence and association with bone mineral density in elderly men and women: The Rotterdam Study. *Bone*. 2004;34(1):195-202. doi:10.1016/j.bone.2003.10.001
- Moayyeri A, Kaptoge S, Dalzell N, et al. Is QUS or DXA Better for Predicting the 10-Year Absolute Risk of Fracture? *Journal of Bone and Mineral Research*. 2009;24(7):1319-1325. doi:10.1359/JBMR.090212
- Stewart A, Kumar V, Reid D. Long-term fracture prediction by DXA and QUS: a 10-year prospective study. *Journal of Bone and Mineral Research*. 2006;21(3):413-418. doi:10.1359/JBMR.051205
- Bauer D, Ewing S, Cauley J, Ensrud K, Cummings S, Orwoll E. Quantitative ultrasound predicts hip and non-spine fracture in men: the MrOS study. *Osteoporosis International*. 2007;18(6):771-777. doi:10.1007/S00198-006-0317-5
- Baim S, Wilson CR, Lewiecki EM, Luckey MM, Downs RW, Lentle BC. Precision assessment and radiation safety for dual-energy x-ray absorptiometry: position paper of the International Society for Clinical Densitometry. *Journal of Clinical Densitometry*. 2005;8(4):371-378. doi:10.1385/jcd:8:4:371
- Bedson J, Croft PR. The discordance between clinical and radiographic knee osteoarthritis: a systematic search and summary of the literature. *BMC Musculoskeletal Disord*. 2008;9:116. doi:10.1186/1471-2474-9-116
- van Helvoort EM, van Spil WE, Jansen MP, et al. Cohort profile: The Applied Public-Private Research enabling OsteoArthritis Clinical Headway (IM-APPROACH) study: a 2-year, European, cohort study to describe, validate and predict phenotypes of osteoarthritis using clinical, imaging and biochemical markers. *BMJ Open*. 2020;10(7):e035101. doi:10.1136/bmjopen-2019-035101
- Bowden JL, Hunter DJ, Deveza LA, et al. Core and adjunctive interventions for osteoarthritis: efficacy and models for implementation. *Nature Reviews Rheumatology*. 2020;16(8):434-447. doi:10.1038/s41584-020-0447-8
- Kenter M, Cohen A. Establishing risk of human experimentation with drugs: lessons from TGN1412. *Lancet*. 2006;368(9544):1387-1391. doi:10.1016/S0140-6736(06)69562-7
- de Visser SJ, Cohen AF, Kenter MJH. Integrating scientific considerations into R&D project valuation. *Nature Biotechnology* 2019 38:1. 2019;38(1):14-18. doi:10.1038/s41587-019-0358-x
- Cohen A. Developing drug prototypes: pharmacology replaces safety and tolerability? *Nat Rev Drug Discov*. 2010;9(11):856-865. doi:10.1038/NRD3227
- Cohen A, Burggraaf J, van Gerven J, Moerland M, Groeneveld G. The use of biomarkers in human pharmacology (Phase I) studies. *Annu Rev Pharmacol Toxicol*. 2015;55:55-74. doi:10.1146/ANNUREV-PHARMTOX-011613-135918
- U. S. Food and Drug Administration. *Note for Guidance on General Considerations for Clinical Trials*; 1997. Accessed October 18, 2021. <https://www.fda.gov/regulatory-information/search-fda-guidance-documents/e8-general-considerations-clinical-trials>
- Laguna M, Algaba F, Bokemeyer C, et al. EAU Guidelines on Testicular Cancer. *ISBN 978-94-92671-07-3*. Published online 2020. <https://uroweb.org/guideline/testicular-cancer/#1>
- Watts NB, Adler RA, Bilezikian JP, et al. Osteoporosis in Men: An Endocrine Society Clinical Practice Guideline. *Journal of Clinical Endocrinology and Metabolism*. 2012;97(6):1802-1822. doi:10.1210/jc.2011-3045
- la Vignera S, Cannarella R, Duca Y, et al. Hypogonadism and sexual dysfunction in testicular tumor survivors: A systematic review. *Frontiers in Endocrinology*. 2019;10(MAY). doi:10.3389/fendo.2019.00264
- Shahinian VB, Kuo YF, Freeman JL, Goodwin JS. Risk of Fracture after Androgen Deprivation for Prostate Cancer. *New England Journal of Medicine*. 2005;352(2):154-164. doi:10.1056/NEJMOA041943
- Greenspan S, Coates P, Sereika S, Nelson J, Trump D, Resnick N. Bone loss after initiation of androgen deprivation therapy in patients with prostate cancer. *The Journal of Clinical Endocrinology and Metabolism*. 2005;90(12):6410-6417. doi:10.1210/JC.2005-0183
- Heidenreich A, Witjes W, Bjerklund-Johansen T, Patel A. Therapies used in prostate cancer patients by European urologists: data on indication with a focus on expectations, perceived barriers and guideline compliance related to the use of bisphosphonates. *Urologica internationalis*. 2012;89(1):30-38. doi:10.1159/000338810
- Hu J, Aprikian A, Vanhuysse M, Dragomir A. Contemporary Population-Based Analysis of Bone Mineral Density Testing in Men Initiating Androgen Deprivation Therapy for Prostate Cancer. *Journal of the National Comprehensive Cancer Network*. 2020;18(10):1374-1381. doi:10.6004/JNCCN.2020.7576
- Kroon J, Buijs JT, van der Horst G, et al. Liposomal delivery of dexamethasone attenuates prostate cancer bone metastatic tumor growth in vivo. *Prostate*. 2015;75(8):815-824. doi:10.1002/pros.22963
- Scher HI, Morris MJ, Stadler WM, et al. Trial design and objectives for castration-resistant prostate cancer: Updated recommendations from the prostate cancer clinical trials working group 3. *Journal of Clinical Oncology*. 2016;34(12):1402-1418. doi:10.1200/JCO.2015.64.2702

SUMMARY

The aim of this thesis was to gain new insights on the diagnostic process- and treatment of pathological conditions of the bone (section I) and joints (section II).

Section I focuses on the impact of male urological malignancies and their therapies on bone health (**Chapters 2, 3**) and in an early phase clinical study, a compound targeting osseous metastases of prostate cancer was investigated (**Chapter 4**). In section II the focus is on inflammatory arthritis and the early clinical development of compounds targeting inflammatory joint disease (**Chapters 5-7**). **Chapters 2 and 5**, are reviews using peer-reviewed literature and registered clinical trials to gain new insights and overall conclusions. For the remaining **Chapters: 3, 4, 6 and 7**, new data was collected.

SECTION I – BONE IN MALE UROLOGICAL MALIGNANCIES

Section I describes if and how testis- and prostate cancer may affect the bone, whether quantitative ultrasonography is of aid to diagnose bone loss in patients with prostate cancer, and whether PEG-liposomal targeted therapy can be safely administered to patients with prostate cancer and osseous metastases.

Chapter 2 is a systematic review using data of testicular cancer survivors to describe the effects on bone quality due to testicular germ cell tumors (TGCT) and its treatment modalities. Both testicular cancer itself and therapies, in particular orchiectomy and chemotherapy, can have a detrimental effect on bone mineral density (BMD), and hence an increased risk for fragility fractures, which may be associated with morbidity and mortality. It does appear that these patients are at risk of developing osteoporosis. This particularly concerns patients treated with chemotherapy. The data also suggest that osteoporosis is more prevalent in patients for whom longer follow-up data are available, which probably reflects that osteoporosis progresses over time.

All included studies reported DXA outcomes, but due to large variations in the study designs and reported endpoints, a direct comparison of results of the included studies was difficult, and a meta-analysis was impossible. In addition, outcomes on important clinical endpoints (fragility fractures) were mostly kept unreported. Notwithstanding these limitations, screening of testicular cancer patients for osteoporosis, in particular those who have had chemotherapy, may prevent fragility fractures and associated morbidity and mortality. Screening programs should be set-up such that its utility and cost-effectiveness can be evaluated unambiguously.

This can be achieved by using the gold standard for the diagnosis of osteoporosis dual-energy x-ray absorptiometry (DXA)-scan. However, DXA-scans are relatively expensive, as it requires a DXA scanner, and cumbersome for patients, as it requires an additional visit to the hospital. Alternatives for this standard can be developed.

Availability of an easy and accessible screening tool would aid in screening high volumes of patients who are at risk, e.g. in the general practitioner's, medical oncologist, urology practice. An example of a larger population at risk of developing osteoporosis, are patients with prostate cancer, especially those who undergo androgen deprivation therapy. In **Chapter 3**, we investigated the utility of quantitative ultrasonography (QUS) as a pre-screening tool for osteoporosis as diagnosed in DXA. QUS is a quick and cheap tool which may be used to assess osseous content and microarchitecture. In addition, the patients were followed-up, to collect data about which patients fractured and whether this was to be expected by their DXA and QUS outcomes.

In summary, calcaneal QUS had a good negative predictive value to identify patients at risk of low bone mineral density, could differentiate between those not at risk, and those who need further diagnostic and treatment follow-up for osteoporosis. Additional studies about the predictive value of QUS for fractures (rather than BMD) in prostate cancer patients are required to learn whether this modality could replace DXA in this population.

In **Chapter 4** of this thesis, a strategy for targeted treatment of osseous metastases is studied. Patients with castration resistant prostate carcinoma who have osseous metastases, are currently treated with corticosteroids. This is in general well-tolerated but can have serious side-effects. These side effects may be improved by pharmacological targeting of the corticosteroids towards osseous metastatic sites. Targeting may be achieved by using liposomal encapsulation of the corticosteroids which utilizes the so-called 'enhanced permeability and retention effect'. With this approach a relatively high local exposure of the active compound can be achieved compared to the systemic exposure, potentially resulting in higher efficacy and lower toxicity. **Chapter 4** describes a first-in-human study of the safety and pharmacokinetics of liposomal dexamethasone, which aims to target osseous metastases of patients with metastasized, castration resistant prostate carcinoma. No safety issues were found, and the pharmacokinetic properties of this formulation are now sufficiently known for further clinical (efficacy) studies.

SECTION II – OSTEOARTHRITIS

Section II focuses on osteoarthritis (OA): OA is a multi-factorial, heterogeneous chronic disease, which involves a chronic low-grade inflammatory state of the joint tissues. The synovium, subchondral bone and cartilage are affected, and cause slow joint degeneration. Clinically, it presents as progressive joint pain and impaired function. Currently, there are no registered disease modifying osteoarthritic drugs.

In a review of recently registered and completed studies as described in **Chapter 5** provides insight in the treatment approaches that are currently under investigation for OA treatment. Four treatment targets are distinguished: pain, inflammation, therapies involving bodily materials, and compounds influencing cartilage metabolism. It appears that many compounds are under investigation, some of which seem promising. However, in the completed studies very few reported a disease modifying effect, let alone without important side effects. It is also recognized that there are limited tools to differentiate between patient phenotypes, and measure disease modifying effects in clinical studies.

It is therefore concluded that although the development of disease modifying OA drugs (DMOADs) is at full throttle some deficiencies were noted. This includes further knowledge on the pathophysiology, development and use of relevant biomarkers to aid drug-candidate selection and evaluation and guide the development of such compounds. These biomarkers should include patient-reported outcomes, based on pain and function, and quantifiable structural outcomes responsive to the disease state. The latter set could include (a set of) soluble biomarkers, novel and existing imaging modalities with standardized acquisition and evaluation protocols, and data obtained through wearables.

PHASE I-II STUDIES FOR DMOAD'S

Chapters 6 and 7 describe two clinical studies: one study concerns an intervention targeting cartilage metabolism of arthritic joints, and the second study focuses on inflammation in osteoarthritic joints.

In **Chapter 6** a double blind, randomized, placebo controlled, single ascending dose, first-in-human study with LRX712 is described. The mode of action of LRX712 is to stimulate cartilage-progenitor cells to develop to mature cartilage cells and restore damaged cartilage. The study was performed in patients with confirmed OA in the knee. Drug administration was by an

intra-articular injection in the affected knee. From this study it could be concluded that this approach is feasible and that high doses caused more local and systemic (elevation of CRP) adverse events of mild and moderate severity than lower doses and placebo. It thus appears that further studies to study the disease modifying effect of LRX712 should be performed with doses up to 25 mg.

Another approach for a potentially disease modifying OA compound targeting inflammation is described in **Chapter 7**. Here, we studied ART-102, a recombinant adeno-associated viral vector, containing a human gene which expresses IFN- β . This expression is under the transcriptional control of a promotor responsive to the pro-inflammatory Nuclear Factor kappa B (NF- κ B). As such, it has an inflammation-driven, anti-inflammatory effect. ART-102 was administered by an intra-articular injection into a target hand joint of patients with inflammatory arthritis. The study was prematurely terminated because the local tolerability of ART-102 in the first 4 patients was too poor to pursue the inclusion of the intended 12 patients. The mechanism responsible for the limited local tolerability issue could not be unraveled. Nevertheless, it does appear that more research is needed to determine the place of recombinant adeno-associated viral vectors as a tool for gene therapy.

De diagnose en behandeling van ziekten is het meest efficiënt als gerichte screening, accurate diagnostische middelen en doelgerichte behandeling kunnen worden toegepast. Voor een optimaal proces, kunnen gedefinieerde risicopopulaties gericht worden gescreend. De methoden voor screening en diagnostiek moeten een goede voorspellende waarde hebben en ten slotte moet de behandeling van een gedetecteerde ziekte doeltreffend zijn: de aandoening moet worden behandeld zonder dat er overmatige bijwerkingen optreden.

Dit proefschrift heeft als doel, tot nieuwe inzichten te komen betreffende het diagnose- en behandelproces voor pathologische aandoeningen van de botten en de gewrichten.

DEEL I

TESTIS-, EN PROSTAATCARCINOOM EN HET SKELET

Deel I beschrijft of- en hoe urologische maligniteiten bij de man (testis- en prostaatkanker) van invloed kunnen zijn op het skelet. Of dit kan worden vastgesteld middels kwantitatieve echografie, en er wordt in een klinische studie onderzocht of gerichte therapie voor bottumoren middels PEG-liposomen veilig kan worden toegediend.

Hoofdstuk 2 – De invloed van testiscarcinoom en de behandeling daarvan op botdichtheid

In **hoofdstuk 2** wordt met behulp van een systematische literatuur review getracht tot inzicht te brengen of testiscarcinoom en de therapieën hiertegen een effect hebben op de botkwaliteit. De behandeling van testiscarcinoom, met name chemotherapie, kan voor teloorgang van de botdichtheid zorgen. Dit maakt het aannemelijk dat patiënten na hun behandeling van testiscarcinoom een verhoogd risico hebben op een lage botkwaliteit. Botten die in een slechte staat verkeren kunnen leiden tot botbreuken bij laag-energetisch trauma en kunnen daarmee leiden tot een negatief effect op de levensduur en kwaliteit van leven.

Dat deze patiëntengroep een verhoogd risico heeft op botontkalking, werd deels bevestigd in de systematische literatuur review in **hoofdstuk 2**. Met name behandeling met chemotherapie en langere follow-up periode verhoogden dit risico. Grote zekerheid over deze conclusies ontbreekt echter, door de wisselende opzet van de studies en wijze van rapportage van de geïncludeerde studies. De uitkomstmaten waren divers, waardoor deze niet

één-op-één kunnen worden vergeleken. Daarnaast ontbreken in veel van de studies belangrijke klinische uitkomstmaten, zoals fractuurfrequentie.

Ondanks deze beperkingen, adviseren we screening voor osteoporose in de populatie mannen die behandeling voor testiscarcinoom heeft ondergaan. Verder prospectief onderzoek moet uitwijzen of opname hiervan in de richtlijnen voor follow-up van (subgroepen) patiënten die behandeld zijn voor testiscarcinoom gerechtvaardigd is.

Hoofdstuk 3 – Diagnostiek van botdichtheid bij patiënten met prostaatcarcinoom

Hoofdstuk 3 gaat in op de methoden voor diagnostiek van osteoporose bij patiënten met prostaatcarcinoom. Bij prostaatcarcinoom zorgt de toegepaste androgeen deprivatie therapie, door farmacologisch geïnduceerde hypogonadisme, voor botontkalking. De gouden standaard voor analyse van de botdichtheid is een dual-energy x-ray absorptiometrie (DEXA)-scan. Het maken van een DEXA-scan is relatief omslachtig: patiënten moeten een aparte afspraak maken en naar het ziekenhuis komen. Daarbij is het duur en niet overal beschikbaar. Quantitative ultrasonography (QUS) is een andere techniek waarmee botdichtheidsmetingen kunnen worden gedaan. Het geeft niet alleen een uitkomst voor de botdichtheid, maar ook voor de microarchitectuur van het bot. Deze metingen kunnen tijdens een poli-afspraak door een getrainde medewerker worden gedaan, met een minder duur apparaat.

In **hoofdstuk 3** wordt bij prostaatkankerpatiënten onderzocht of een lage botdichtheid kan worden geïdentificeerd met calcaneus QUS-metingen, door de uitkomst hiervan te vergelijken met de uitkomst van hun DEXA-scans. Daarnaast werden patiënten vervolgd in de tijd, om vast te stellen welke patiënten een fractuur opliepen. Calcaneus QUS bleek een uitstekend hulpmiddel te zijn voor de identificatie van mensen die een verhoogd risico hebben op een lage botdichtheid. Door QUS zouden patiënten kunnen worden geselecteerd die verdere diagnostiek- en behandeling tegen osteoporose nodig hebben. Op dit moment is er nog onvoldoende bekend over de waarde van QUS voor het voorspellen van fracturen om DEXA volledig te vervangen.

Hoofdstuk 4 – Targeting van botmetastasen

In **hoofdstuk 4** wordt een first-in-human studie beschreven. Het onderzoeksmiddel, liposomale dexamethason, is ontwikkeld met het doel zich op te hopen in botmetastasen. Door een geneesmiddel (dexamethason) in

kleine vetbolletjes (liposomen) te verpakken zou de blootstelling aan het geneesmiddel ter plaatse van de botmetastasen hoger moeten zijn dan elders in het lichaam. Zo kan met deze liposomale formulering van het geneesmiddel gerichte behandeling worden bereikt, waardoor in theorie een hogere effectiviteit- en minder toxiciteit wordt bewerkstelligd.

In deze studie werden de veiligheid en farmacokinetiek van liposomale dexamethason onderzocht bij patiënten met ossaal gemetastaseerd, castratie-resistente prostaatkanker. De veiligheid blijkt nu goed en de farmacokinetiek is voldoende bekend voor verdere ontwikkeling van het middel. Wat echter nog niet duidelijk is uit dit onderzoek, is of de liposomen daadwerkelijk meer worden opgenomen in de metastasen dan elders in het lichaam en of dit ook een positief behandelingseffect heeft.

DEEL II

FARMACOTHERAPEUTISCHE INTERVENTIES VOOR ARTROSE

Deel II is gericht op gewrichtsartrose: een pathofysiologische toestand van de gewrichtsweefsels die gepaard gaat met laaggradige inflammatie. Hierbij zijn het synovium, subchondraal bot en het kraakbeen betrokken. De inflammatie en de door artrose veroorzaakte degeneratie van het gewricht zorgen voor aanpassing van de gewichtsstructuren, waardoor pijn- en de functiebeperking van het gewicht veroorzaakt worden. Op dit moment zijn er nog geen behandelingen geregistreerd die artrose kunnen vertragen of genezen.

De ontwikkeling van middelen tegen artrose wordt bemoeilijkt doordat artrose een zeer heterogene en multifactoriële aandoening is. In andere woorden: meerdere, nog onbekende, pathofysiologische wegen leiden tot het ontstaan van artrose. Daarnaast gaat de degeneratie langzaam, waardoor geneesmiddeleffecten moeilijk vast te leggen zijn.

Door middel van een review van recent geregistreerde- en afrondde studies, wordt in **hoofdstuk 5** inzichtelijk gemaakt op welke vlakken de huidige ontwikkelingen gaande zijn. Dit is opgesplitst in vier categorieën: pijn, inflammatie, therapieën met lichaamseigen materialen, en therapieën die aanpassing van het kraakbeenmetabolisme tot doel hebben. Er werden veel kandidaat-middelen gevonden in de review, sommigen daarvan lijken hoopvol. Bij de afgeronde studies werden echter nauwelijks studies gevonden die een ziektemodificerend effect van een middel hadden, laat staan zonder belangrijke bijwerkingen.

Op dit moment zijn er weinig tools (bijvoorbeeld biomarkers) voorhanden om tussen patiënten te kunnen differentiëren. Ook in het meten van de effecten kunnen nog stappen worden gemaakt. Hierin moet een balans worden gevonden in uitkomsten die door de patiënt gerapporteerd worden, op basis van pijn en functie, en objectieve, kwantificeerbare uitkomstmaten, zoals bijvoorbeeld biomarkers in het bloed, in beeldvorming of gemeten met wearables.

Hoewel de ontwikkeling van artrose geneesmiddelen dus op volle toeren is, zou deze geholpen zijn bij het hebben van universele biomarkers die deze ontwikkeling kunnen sturen- en uitkomsten beter kunnen evalueren

Hoofdstukken 6 en 7 – Fase I-II studies naar middelen voor artrose

In twee van de beschreven categorieën van **hoofdstuk 5** – het beïnvloeden van de inflammatie en het kraakbeenmetabolisme in artrotische gewrichten – zijn in dit proefschrift klinische studies beschreven: in **hoofdstukken 6 en 7**. Beiden beschrijven vroege fase klinische studies, waarin werd beoogd de systemische veiligheid, lokale tolerabiliteit en de farmacokinetiek te onderzoeken.

Het middel LRX712 stimuleert, na intra-articulaire toediening in de knie, de ontwikkeling van kraakbeen-voorloper cellen tot volwassen kraakbeen-cellen. Dit moet het beschadigde kraakbeen herstellen. Tijdens de in **hoofdstuk 6** beschreven first-in-human studie bleken hogere doseringen meer (mild- en matig ernstige) ongewilde lokale reacties te geven dan lagere doseringen en placebo. Bij een post-hoc analyse, werden ook systemisch verhoogde concentraties van het C-reactief proteïne gevonden bij de patiënten die een hogere dosering kregen. Desalniettemin wordt het veiligheids- en tolerabiliteits-profiel van de middeldoseringen die getest zijn voldoende geacht voor verdere ontwikkeling van LRX712 als middel tegen knie-artrose.

Effectiviteit is wel geëxploreerd in dit onderzoek, middels activiteits monitoring en vragenlijsten over pijn- en functionaliteit, maar is nog niet aangetoond.

In **hoofdstuk 7** wordt een het middel ART-IO2 onderzocht. Nadat radiologisch synovitis werd vastgesteld, werd het middel middels intra-articulair toediening in een vingergewricht van patiënten met inflammatoire artritis gebracht. ART-IO2 wordt geïnternaliseerd in de synoviocyten, waar het – door stimulatie door NF- κ B en HGHPA – IFN- β tot expressie brengt, dat een anti-inflammatoir effect moet hebben in het gewricht.

Helaas bleek de lokale tolerabiliteit van ART-102 onvoldoende om de voorgenomen 12 patiënten te includeren; de studie werd vroegtijdig gestopt. In de MRI-scans gemaakt na de dosering, werd een verergering van de inflammatie ter plaatse van het target gewricht ten opzichte van die voor de dosering bevestigd. Geen van de geïncludeerde patiënten heeft een operatie aan het geïnjecteerde gewricht ondergaan, wat weefselonderzoek en het verder vaststellen van de exacte etiologie van de bijwerkingen onmogelijk maakt.

CURRICULUM VITAE

Josine (J.P.M.) van Alphen-Vrouwe (Amsterdam, 1989) graduated from secondary school in 2008 (Herbert Vissers College, Nieuw Venne) and started medical school at the Vrije Universiteit, Brussels, BE, in 2009. In 2010, she continued her studies at Leiden University, Leiden, NL. In Leiden, she combined her studies with competitive rowing. As a part of her masters, she arranged a scientific rotation in the musculoskeletal radiology department of the Johns Hopkins Medical Institute, (Baltimore, MD, USA) where she executed studies for spondylolisthesis and spinal variances.

In 2015, Josine obtained her medical degree, upon which she started her career as a physician in the surgical department of the Haaglanden Medical Center (The Hague, NL). In 2016, she started as a PhD-student (project leader and research physician) at the Centre for Human Drug Research (CHDR, Leiden, NL). At CHDR she carried out multiple early phase clinical studies. She studied pharmacological interventions covering several fields, including rheumatology, uro-oncology, immunology, and gastroenterology. Her research was under the supervision of prof. dr. Jacobus Burggraaf and prof. dr. Susanne Osanto. Whilst working at CHDR, she was also trained as clinical pharmacologist. In 2021 Josine returned to work clinically and in July 2022 she advanced her radiology residency in the university medical center of Utrecht, (Utrecht, NL).

SCIENTIFIC PUBLICATIONS

- Vrouwe JPM**, Hennis PML, Hamdy NAT, Osanto S, Willemse PM. Risk of osteoporosis in testicular germ cell tumour survivors: A systematic review of the literature. *BJUI Compass*. 2022. doi: 10.1002/bco2.183
- Vrouwe JPM**, Burggraaf J., Kloppenburg M, & Stuurman FE Challenges and opportunities of pharmacological interventions for osteoarthritis: A review of current clinical trials and developments. *Osteoarthritis and Cartilage Open*. 2021. 3(4), doi:10.1016/j.ocarto.2021.100212
- Vrouwe JPM**, Meulenberg JJM, Klarenbeek NB, Cañete AN, Reijnierse M, Ruitkamp G, Bevaart L, Lamers RJ, Kloppenburg M, Nelissen RGHH, Huizinga TWJ, Burggraaf J, Kamerling IMC. Administration of an adeno-associated viral vector expressing interferon- β in patients with inflammatory hand arthritis, results of a phase I/II study. *Osteoarthritis Cartilage*. 2021 Oct 6:S1063-4584(21)00930-4. doi: 10.1016/j.joca.2021.09.013.
- Vrouwe JPM**, Kamerling IMC, van Esdonk MJ, Metselaar JM, Stuurman FE, van der Pluijm G, Burggraaf J, Osanto S. An exploratory first-in-man study to investigate the pharmacokinetics and safety of liposomal dexamethasone at a 2- and 1-week interval in patients with metastatic castration resistant prostate cancer. *Pharmacol Res Perspect*. 2021 Oct;9(5):e00845. doi: 10.1002/prp2.845.
- Vrouwe JPM**, de Jongh SJ, Voskuil FJ, Schmidt I, Westerhof J, Koorstra JJ, de Kam ML, Karrenbeld A, Hardwick JCH, Robinson DJ, Burggraaf J, Kamerling IMC, Nagengast WB. The optimal imaging window for dysplastic colorectal polyp detection using c-Met-targeted fluorescence molecular endoscopy. *J Nucl Med*. 2020 Oct;61(10):1435-1441. doi: 10.2967/jnumed.119.238790.

DANKWOORD

Dit proefschrift is het resultaat van een leerzame periode die zonder de hulp van velen niet tot een succesvol einde was gekomen. Ik benoem hierbij in het bijzonder:

Dr. de Visser-Kamerling, lieve Ingrid, 5 jaar lang was jij voor mij een steun en supervisor. Je stond altijd klaar met goede raad en je precieze blik, dankjewel.

Dr. Stuurman, beste Rik, dank voor jouw eeuwige optimisme en onze geranium-sessies.

Prof. dr. Burggraaf, beste Koos, dank voor je pragmatische blik en aanpak, en de geruststellende woorden in mindere tijden.

Prof. dr. Osanto, beste Susanne, dank voor jouw expertise en enorme tijds-investering in mijn promotie. Ik heb jou leren kennen als een perfectionist die ernaar streeft haar leerling op een volgend niveau te laten denken.

CHDR-collega's: zonder CRU-personeel, QA-officers, screenings-unit, data-managers, farmacometricians, recruitment, CTA'S, de AdminCRU, etc., zou het CHDR niet werken.

Lieve Diana, Voor mij ben jij de representatie van het 'hart' van het CHDR.

Eiland – Berti, Titia, Fran, Sam, Charlotte en Kris. Ondanks dat we ieder op ons eigen onderzoeks-eilandje werkten, is er heel wat smart gedeeld deze jaren.

Roeiploeg, bedankt voor het uitlaatklepje dat de roeisessies (en de koffie achteraf) mij bieden.

Alissa en Maaïke, altijd goed voor een gezellig rondje fietsen, bijpraten over een dinertje over alles wat gaande is in ons leven en een serieuze noot of raadpleging waar nodig.

Tom en Margit: Ik kan me geen fijnere schoonouders wensen; huize 'van Alphen' zit vol goede raad en staat open voor avonturen: het is een warm thuis.

Mijn broers, Nico en Christ en mijn schoonzussen en zwagers, ben ik blij en trots dat we in een warme relatie als de onze.

Tessa en Debbie, bedankt voor onze vriendschap en de vele avonturen in de afgelopen 20 jaar.

Anne, mijn lieve zus, bedankt voor de nooit-aflatende bereidheid tot telefoon-gesprekken om nuchtere vaststellingen of emotionele ontladingen te delen.

Papa en mama, ik prijs mij gelukkig met jullie onvoorwaardelijke liefde, steun, belangstelling, raad en daad. Jullie zijn voor mij een lichtend voorbeeld als mens en als ouder.

Thomas en Nienke, kleine lieverds. Jullie bestaan brengt perspectief in vele zaken.

En tot slot, mijn liefste René. Jouw steun, relativering en liefde hebben mij al vaak op sterkte gehouden of teruggebracht.

