



Universiteit  
Leiden  
The Netherlands

## Upgrading construction and demolition waste management from downcycling to recycling in the Netherlands

Zhang, C.; Hu, M.; Yang, X.; Miranda Xicotencatl, B.; Sprecher, B.; Di Maio, F.; ... ; Tukker, A.

### Citation

Zhang, C., Hu, M., Yang, X., Miranda Xicotencatl, B., Sprecher, B., Di Maio, F., ... Tukker, A. (2020). Upgrading construction and demolition waste management from downcycling to recycling in the Netherlands. *Journal Of Cleaner Production*, 266.

doi:10.1016/j.jclepro.2020.121718

Version: Publisher's Version

License: [Licensed under Article 25fa Copyright Act/Law \(Amendment Taverne\)](#)

Downloaded from: <https://hdl.handle.net/1887/3200781>

**Note:** To cite this publication please use the final published version (if applicable).

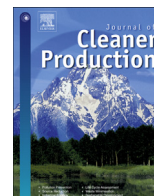

# Upgrading construction and demolition waste management from downcycling to recycling in the Netherlands

Chunbo Zhang<sup>a</sup>, Mingming Hu<sup>a, b, \*</sup>, Xining Yang<sup>a</sup>, Brenda Miranda-Xicotencatl<sup>a</sup>, Benjamin Sprecher<sup>a</sup>, Francesco Di Maio<sup>c</sup>, Xiaoyang Zhong<sup>a</sup>, Arnold Tukker<sup>a, d</sup>

<sup>a</sup> Institute of Environmental Sciences, Leiden University, 2300, RA, Leiden, Netherlands

<sup>b</sup> School of Management Science and Real Estate, Chongqing University, Chongqing, 40045, China

<sup>c</sup> Faculty of Civil Engineering and Geosciences, Delft University of Technology, 2628, CN, Delft, the Netherlands

<sup>d</sup> Netherlands Organization for Applied Scientific Research TNO, 2595, DA, Den Haag, Netherlands

## ARTICLE INFO

### Article history:

Received 30 April 2019

Received in revised form

10 February 2020

Accepted 13 April 2020

Available online 22 April 2020

Handling editor: Yutao Wang

### Keywords:

Construction and demolition waste (CDW)

Material flow analysis (MFA)

Waste concrete

Recycling

Downcycling

The Netherlands

## ABSTRACT

Urban mining from construction and demolition waste (CDW) is highly relevant for the circular economy ambitions of the European Union (EU). Given the large volumes involved, end-of-life (EoL) concrete is identified as one of the priority streams for CDW recycling in most EU countries, but it is currently largely downcycled or even landfilled. The European projects C2CA and VEEP have proposed several cost-effective technologies to recover EoL concrete for new concrete manufacturing. To understand the potential effects of large-scale implementation of those recycling technologies on the circular construction, this study deployed static material flow analysis (MFA) for a set of EoL concrete management scenarios in the Netherlands constructed by considering the development factors in two, technological and temporal dimensions. On the technological dimension, three treatment systems for EoL concrete management, namely: business-as-usual treatment, C2CA technological system and VEEP technological system were investigated. On the temporal dimension, 2015 was selected as the reference year, representing the current situation, and 2025 as the future year for the prospective analysis. The results show that the development of cost-effective technologies has the potential to improve the share of recycling (as opposed to downcycling) in the Netherlands from around 5% in 2015 up to 22%–32% in 2025. From the academic aspect, the presented work illustrates how the temporal dimension can be included in the static MFA study to explore the potential effects in the future.

© 2020 Elsevier Ltd. All rights reserved.

## 1. Introduction

The emergent concept of “urban mining” illustrates how the use of end-of-life (EoL) products and materials as new resources is increasingly accepted. Construction and Demolition Waste (CDW) is one of the heaviest and most voluminous waste streams generated in the European Union (EU). Because of the large volumes and the high potential for both recycling and re-use and of these materials, CDW has been identified by the European Commission (EC) as a priority waste stream (EC, 2018). Indeed, EU policies and regulations have contributed considerably to reduce the amount of CDW that is landfilled.

For example, the Waste Framework Directive (WFD) (EC, 2008) requires member states to take any necessary measures to achieve a minimum target of 70% (by weight) of CDW by 2020 for re-use, recycling and other recovery, including backfilling. According to the WFD definition, “recycling rates” refers to the rates of both recycling and downcycling (i.e. the practice of using recycled material in an application of less value than the application) (Allwood, 2014). Energy recovery is excluded from this scope and category 17 05 04 (excavated material) is not included in the calculation of the target.

The most widely currently applied recycling practice for CDW is crushing to secondary aggregates. These substitute virgin aggregates in various applications, usually road foundation (Di Maria et al., 2018). This can be labeled as downcycling. Downcycling also occurs when scraps are polluted or mixed with lower quality scrap during recycling (Koffler and Florin, 2013). By using life cycle assessment and life cycle costing, Di Maria et al. (2018) explore the

\* Corresponding author. Institute of Environmental Sciences, Leiden University, 2300, RA, Leiden, Netherlands.

E-mail address: [hu@cml.leidenuniv.nl](mailto:hu@cml.leidenuniv.nl) (M. Hu).

### Abbreviations

BAU	Business-as-usual
CBS	Central Bureau of Statistics of Netherlands
CDW	Construction and demolition waste
C2CA	European Commission 7th Framework Program project "Advanced Technologies for the Production of Cement and Clean Aggregates from Construction and Demolition Waste"
EoL	End-of-life
EC	European Commission
EIB	Economic Institute for Construction of the Netherlands
ERMCO	European Ready Mixed Concrete Organization
EU	European Union
LAP2	Dutch Second Waste Management Plan for the period 2009–2021
MFA	Material flow analysis
UEPG	European Aggregates Association
USGS	United States Geological Survey
VEEP	European Commission Horizon 2020 project "Cost-Effective Recycling of C&DW in High Added Value Energy Efficient Prefabricated Concrete Components for Massive Retrofitting of our Built Environment"
WFD	Waste Framework Directive

effect of upgrading CDW management from landfilling to down-cycling, and then from downcycling to recycling. Both cases reduce the environmental impact and cost of the system. However, Zhang et al. (2018) found that downcycling of concrete is only slightly worse than recycling, and could, in the context of a developing country, still be considered a reasonable method of dealing with CDW. Thus, regarding "downcycling or recycling" issue, we cannot definitively claim that recycling is superior to downcycling, without taking into account regional characteristics.

Based on the "waste hierarchy" defined in the WFD, there are five levels of waste treatment options (EC, 2008). Ranking from more to less desirable: 1) prevention; 2) re-use; 3) recycling; 4) other recovery; and 5) disposal. Here *recycling* is defined as "any recovery operation by which waste materials are reprocessed into products, materials or substances whether for the original or other purposes".

Analogously, there are five levels of EoL concrete treatment: 1) prevention of EoL concrete, 2) re-use of concrete elements, 3) recycling into aggregates for concrete production, 4) recycling into aggregates for road construction or backfilling, and 5) landfilling. Accordingly, the concept of "recycling of concrete" can be defined as any recovery operation by which EoL concrete is reprocessed into materials for new concrete production. "Downcycling of concrete" can be defined as any recovery operation by which EoL concrete is reprocessed into materials for backfilling.

A general understanding is that in many EU countries an important fraction of EoL concrete is still landfilled together with other stony materials resulting from the demolition of buildings (Eurostat, 2018). The second major outlet is crushing to granulate that is used in road foundation. From an environmental point of view, road foundation is a proper recycling route that involves relatively minor bulk transport of the material from source to application and the granulate from EoL concrete has a positive value. A very minor fraction of crushed EoL concrete is used as a

partial (up to 20–30%) replacement of >4 mm aggregate in new concrete. The latter application is generally not economically competitive, and its environmental benefits are comparable to the use in road foundation. We note that neither road foundation nor partial replacement of coarse aggregate in new concrete is a sustainable solution for EoL concrete in the long run, due to the fact that the net growth of the road infrastructure is shrinking and may at some point stop. At that point, no or hardly any additional granulate is needed in road foundation.

Consequently, a solution will need to be found for a large amount of EoL concrete that cannot be absorbed in roads. A potential outlet for this surplus stream is to process it into clean aggregates and use it for new concrete production. However, the current method (wet process) to produce recycled concrete aggregates is costly (Zhang et al., 2019). In order to reduce the processing cost for EoL concrete recycling and simultaneously improve the product quality, the C2CA project (funded by the EU's 7th Framework Program, Advanced Technologies for the Production of Cement and Clean Aggregates from Construction and Demolition Waste) has investigated a novel solution. It relies on: 1) improving dismantling and demolition methods to generate cleaner EoL concrete; 2) Advancing a Dry Recovery system for in-situ EoL concrete processing; and 3) developing on-line sensors to guarantee the quality of the recycled coarse products (4–22 mm). The result is a secondary aggregate that can be used for concrete production. The process also supplies calcium-rich fines (0–4 mm), which can potentially substitute limestone for clinker production in cement kilns. A second project, the EU Horizon 2020 funded VEEP project (Cost-Effective Recycling of C&DW in High Added Value Energy Efficient Prefabricated Concrete Components for Massive Retrofitting of our Built Environment), developed innovative technology where the 0–4 mm fraction is further refined via a Heating-Air Classification System to produce secondary sand (0.125–4 mm) and cementitious filler (<0.125 mm) (Zhang et al., 2020, 2019). In this study, we explore the potential market volume for large-scale implementation of the C2CA and VEEP technologies.

Re-use of components and materials is placed higher in the waste management hierarchy than recycling (EC, 2008). For many cast on-site structures, it may be physically impossible to separate concrete components since they were cast simultaneously (Purnell and Dunster, 2010). However, re-use may not always be possible in the concrete sector. For instance, prefabricated concrete components have specific mechanical properties and dimension, and may not be re-useable in a new building; additionally, many infrastructure concrete components are simply too bulky to be transported. Thus, re-use of concrete is barely considered as a route for concrete recovery.

Besides the hierarchy of CDW management, it is also necessary to take into account the economics of CDW management. Even if a waste flow can create value (e.g. wood, via energy recovery), the demolition contractor will incur costs to move the material off-site. In practice, the value of most CDW waste flows is set at 0 €/t. Based on the experience with waste treatment in the Netherlands in 2012, the market value of each fraction in CDW in the Netherlands in 2012 is summarized in Table 1. Table 1 shows that when sold on-site directly or if first processed into secondary raw material, over 90% of the value embedded in CDW comes from metals. Metals are a high-value stream in CDW, and are often already recycled to a high degree (Koutamanis et al., 2018).

In terms of volume, the composition of CDW varies between nations, regions and even projects. Depending on the nature of the construction project, concrete waste is 40–85% of the total waste generated on-site (Gálvez-Martos et al., 2018). Fig. 1 shows the composition of CDW in various countries and regions. Except for Spain and Finland, EoL concrete accounts for more than 40% of the

**Table 1**  
Economic value of each fraction in CDW in the Netherlands in 2012.

Fraction	% of CDW <sup>a</sup>	Price for selling in situ	Value share	waste process <sup>a</sup>	% of fraction <sup>a</sup>	Price for secondary material	Value share
Concrete and other masonry material	64.02%	0 €/t <sup>b</sup>	0%	Recycling for concrete industry	3% <sup>e</sup>	10.50 €/t <sup>b</sup>	0.3%
				Downcycling for site elevation	19% <sup>e</sup>	0 €/t <sup>f</sup>	0%
				Downcycling as road base material	78% <sup>e</sup>	4.50 €/t <sup>b</sup>	3.7%
Metals	12.88%	119–200 €/t <sup>c</sup>	100%	Unknown	4%	0.00€/t	0%
Sorting residue	9.35%	/	0%	Metals recycling	96%	470.00€/t <sup>d</sup>	96.0%
				Landfill	4%	0.00€/t	0%
				Unknown	45%	0.00€/t	0%
Wood	6.10%	/	0%	Incineration	51%	0.00€/t	0%
				Unknown	11%	0.00€/t	0%
				Recycling in chipboard	13%	0.00€/t	0%
Glass	0.32%	/	0%	Incineration	76%	0.00€/t	0%
				Glass recycling	100%	0.00€/t	0%
Plastics	0.76%	/	0%	Incineration/landfill/recycling	100%	0.00€/t	0%
Paper	0.22%	/	0%	Paper recycling	100%	0.00€/t	0%
Insulation	0.07%	/	0%	Incineration/landfill/recycling	100%	0.00€/t	0%
Asbestos	1.42%	/	0%	Landfill	100%	0.00€/t	0%
Mixed waste	4.87%	/	0%	Incineration/landfill	100%	0.00€/t	0%

Source: <sup>a</sup> (Mulders, 2013); <sup>b</sup> according to the field service at Strukton recycling site in Hoorn, the Netherlands in 2016, the mixed stony waste and clean EoL concrete are seen as waste without economic value, recycling site will charge 3.5–4.5 €/t gate fee for disposal of those waste, if those waste are recycled as concrete aggregates, it will have much higher price (10–11 €/t) than recycled as road base aggregates (4.5 €/t); <sup>c</sup> data referred HISER project internal report D5.3, prices of selling metals at demolition site in 2016 were as follows: aluminum 200 €/t, metal beam 137 €/t, metal plate 119 €/t, other ferrous metals were 133 €/t; <sup>d</sup> data referred to the price of steel production process in Ecoinvent database 3.4 for OpenLCA: “steel production, chromium steel 18/8, hot rolled | steel, chromium steel 18/8, hot rolled | Cutoff, U-RER”; <sup>e</sup> (Zuidema et al., 2016); <sup>f</sup> stony waste can be recovered as secondary product for elevating the foundation of road and building to reduce the use of sand, however, sometimes site elevation is a way for disposal of surplus stony waste which is seen as waste.

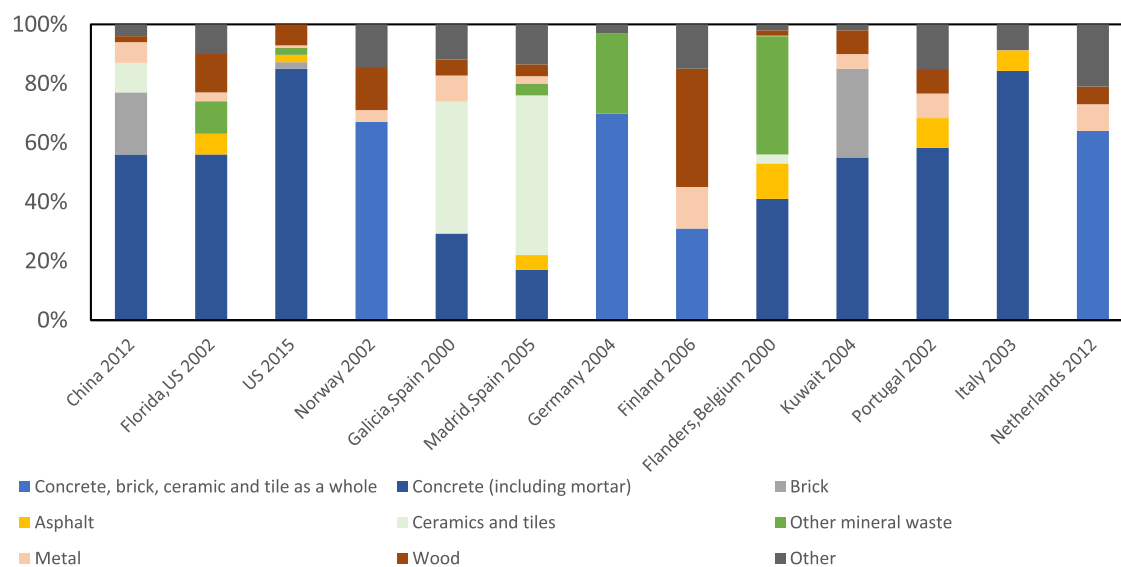

**Fig. 1.** Compositions of construction and demolition waste in different countries. Note: 1) extracted soil is excluded; 2) due to the difference of time and scale in those estimations, the results may be not comparable to each other; 3) data source: China (Dong et al., 2017), Florida, US (Cochran et al., 2007), US (Office of Resource Conservation and Recovery, 2018), Norway (Andr and Bratteb, 2016), Galicia, Spain (Martínez Lage et al., 2013), Madrid, Spain (Bio Intelligence Service, 2011), Kuwait (Kartam et al., 2004), Portugal and Italy (Mália et al., 2013), The Netherlands (Mulders, 2013).

total CDW (by weight). For the EU overall, EoL concrete makes up 60–70% of total CDW (Bio Intelligence Service, 2011). Therefore, urban mining of EoL concrete can be expected to be a good starting point for explorations and development of urban mining and CDW management.

Most EU member states do not have good quality data on the generation and disposal of CDW (Monier et al., 2017). In some member states, concrete is statistically included in masonry waste or mineral waste with other waste such as bricks, tiles, and ceramics. Therefore it is currently not possible to estimate the actual

percentage of recycling or downcycling for the EoL concrete in the EU.

In the Netherlands, the recycling rate for CDW has reached 95% since 2001, due to a landfill ban implemented in 1997 (Hu et al., 2013). Since 2010 a recycling rate of almost 100% was achieved (Eurostat, 2018). In 2015, CDW was mainly used successfully in road foundations (78% by weight) and only to a limited extent in concrete (3% by weight). The rest (19%) was disposed through site elevation for road and buildings (Zuidema et al., 2016). The Dutch Second Waste Management Plan for the period 2009–2021 (LAP2)

(VROM, 2008) set a target for the stream of CDW as: keeping the current recycling rate of CDW and reducing the environmental impact within the life cycle of CDW management. Under the new chain approach in LAP2, CDW was selected as one of the seven priority flows, the environmental impact of which needs to be reduced by 20% by 2015. However, the generation of EoL concrete is expected to increase from 10.5 Mt in 2003 to 22 Mt in 2025 (VROM, 2008). While road construction activity is expected to remain stable in the near future, the amount of CDW is constantly increasing. The Netherlands is already facing a problem of saturation of low-quality road base aggregate in the aggregates market (Di Maria et al., 2018), and therefore this country is a suitable case study to explore the contribution of innovative technologies in recycling of EoL concrete.

The objective of this study is to quantify the potential market volume for large-scale implementation of the C2CA and VEEP technology systems for EoL concrete management in the Netherlands. Material flow analysis (MFA) has been proved as a useful quantitative tool for exploring the urban metabolism for the resource supply and waste management at the region level (Zhang et al., 2018; Wang et al., 2016; Sevigné-Itoiz et al., 2015). To explore if the proposed solution will lead to a more sustainable CDW management in a long run, an MFA study for the concrete industry in the Netherlands is carried out to project the concrete production and disposal in 2015 and 2025 according to four socio-economic development scenarios. Reviewing the MFA results of different development scenarios, the potential effects of large-scale implementation of the C2CA technology system in the Netherlands are outlined. The results of the analyses are used for policy recommendations on sustainable CDW management at a regional level.

## 2. Methods

According to van der Voet (1996), the framework of a typical Substance flow analysis study includes: 1) definition of the system, 2) quantification; 3) interpretation. For the quantification and modeling of the system, there are basically three modeling methods (van der Voet, 1996): 1) accounting/bookkeeping modeling which arranges gathered data on the identified flows and stocks into a consistent overview; 2) static modeling which defines flows and stocks in a certain system as variables dependent on others, resulting serials of equations to be solved for one specific year or for the “steady-state” equilibrium situation; 3) and dynamic modeling which includes changes in the system’s stocks and flows over a time frame. According to the definitions of those three modeling methods, the modeling approach we applied in this study is a “semi-dynamic” model which not only applies linear equations with transfer coefficients in a steady-state for calculation as the static model does but also from a temporal perspective projects situations for specific future years as the dynamic model does.

### 2.1. Goal and scope definition

The objective of this study is to quantify and project the potential effects of large-scale implementation of the C2CA technology and VEEP technology for recycling EoL concrete into coarse aggregate for new concrete manufacturing in the Netherlands. Static modeling is selected in this study. Fundamental variables for an MFA study, time, material, space, processes and flows, are defined (van der Voet, 1996).

- Time

The year 2015 serves as the base year for concrete and related waste cycles in the Netherlands. We contrast the potential of

recycling options of EoL concrete made possible by the C2CA and VEEP technologies via a projection to the year 2025.

- Material

The following materials related to the life cycle of concrete from production to disposal are of relevance in this study: 1) raw materials for concrete production: gravel, sand, cement; chloridion in marine aggregates cannot be used in concrete production because it corrodes rebar thus marine aggregates are excluded in the concrete MFA model. 2) EoL concrete from residential buildings, non-residential buildings, civil engineering, and concrete production. 3) secondary products that are made of EoL concrete, including secondary sand, secondary gravel, and secondary cement. Table 2 gives the concrete composition that was used in the mass balance calculation of the study. A large portion of the water evaporates during the hydration process of concrete. To simplify the MFA system, evaporated water was left out of scope.

- Space

The Netherlands is selected as the case for this study. Thus, the national boundary of the Netherlands is the geographical boundary for the system.

- Processes and flows

Relevant processes and flows are determined based on concrete production and disposal in the Netherlands. Fig. 2 shows a schematic representation of the MFA system, constructed using software STAN 2.5 (Cencic and Rechberger, 2008). The exports and imports of raw aggregates and cement were presented as net import in the model.

### 2.2. System quantification

#### 2.2.1. Scenario definitions

We consider three different technological systems that determine how EoL concrete is handled at the end of life phase: Business-as-usual (BAU), the C2CA technological system, and the VEEP technological system. Mass balances for each technological system were elaborated on in Zhang et al. (2019).

In the BAU system, most of EoL concrete is recovered by simply crushing concrete so that it can be used as backfilling material, while a minor fraction will be recycled as concrete aggregate through the wet process which aims to recycle EoL concrete for production of coarse aggregate (52.9% by weight) and the associated by-products sieve sand (42.5% by weight) and sludge (4.6% by weight) (Zhang et al., 2019). The sieve sand does not meet the quality standard of fine concrete aggregate thus it cannot be used in new concrete manufacturing and it is usually disposed in site elevation. The sludge is seen as a waste to be landfilled.

In the C2CA system, the Advanced Dry Recovery technology can recycle EoL concrete for production of clean coarse aggregate (68%

**Table 2**  
Composition of 1 m<sup>3</sup> hardened concrete.

Raw material	Size range	Mass (kg)	Percentage (%)
Virgin/secondary gravel	4–22 mm	1150	47.92%
Virgin/secondary sand	0.125–4 mm	750	31.25%
Virgin/secondary cement	<0.125 mm	350	14.58%
Water	/	150	6.25%
Total	/	2400	100.00%

Source: concrete recipe from VEEP project internal report D6.2.

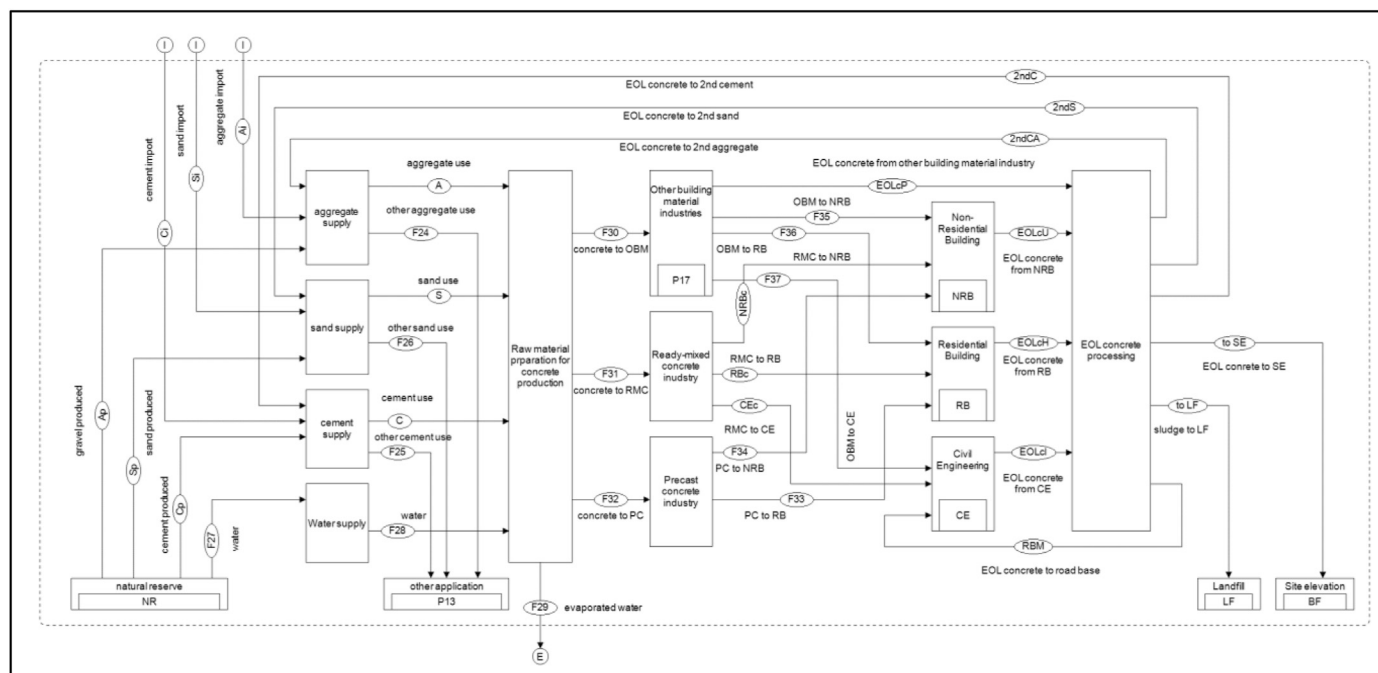

Fig. 2. Concrete cycle model in the Netherlands. Note: Processes are represented by rectangles; material flows are represented by arrows.

by weight), and yields as by-product sieve sand (32% by weight), which is a mixture of fine aggregate and hydrated cement (Zhang et al., 2019). The fate of the sieve sand will be the same as in the BAU scenario.

In the **VEEP** system, apart from application of the Advanced Dry Recovery technology, a Heating-air Classification system has been developed to separate the sieve sand into clean sand (80% by weight) and cementitious particle (20% by weight), which can be applied as the substitution of fine aggregate and cement in new concrete manufacturing (Zhang et al., 2019).

The BAU scenario represents the situation that the wet process will not be widely accepted by the market since it is expensive. Therefore, the aggregates recycled from EoL concrete will be first used to satisfy the demand for road base construction instead of for new concrete manufacture. After this, all surplus EoL concrete aggregates will be used as filler for elevation of foundation layers of buildings. The C2CA and VEEP system are more financially competitive compared to the wet process because (Zhang et al., 2019): 1) they used less laborers thus resulting in less personnel cost; 2) they do not generate waste (sludge) thus avoiding waste disposal cost; 3) VEEP system use mobile recycling facilities which saves the cost on waste transportation; 4) VEEP system can produce high-value secondary product thus increasing the proceeds. Since the C2CA and VEEP system represent the technology that is assumed to be cheap enough to be accepted by the market, after the demand for road base construction is satisfied, it is assumed that all the EoL concrete will be used in new concrete manufacture.

The baseline scenario of the 2015 concrete cycle is given in the 2015 BAU scenario. We then apply our three technological systems to the year 2025. This gives the four scenarios given in Table 3.

### 2.2.2. EoL concrete generation

To the best of the authors' knowledge, the Central Bureau of Statistics (CBS) of Netherlands does not have official statistics specifying EoL concrete. Most statistics are at the CDW or stony waste level, as shown in Fig. 3. The amount of CDW increased sharply and then remained fairly stable after 2000 (CBS et al., 2017).

Data on supply of mineral, stony waste from CBS (2018) was collected through delivery and processing of waste at recycling companies in which it may not include all the stony waste generated, thus the amount of generated stony waste is less than that from the EIB (Zuidema et al., 2016). Hofstra et al. (2006) projected an increasing trend of EoL concrete generation from 2003 to 2025, however, the projection on EoL concrete generation the by the EIB (Zuidema et al., 2016) is more corresponding to the real historical data from CBS et al. (2017). Thus the data of EoL concrete generation in 2015 (11.3 Mt) and 2025 (16.3 Mt) from the EIB was selected for concrete MFA modeling in the study.

The sources of EoL concrete are categorized in four sectors as shown in Table 4.

### 2.2.3. EoL concrete treatment

At a certain point in the future, the quantity of EoL-concrete from demolition will exceed what can be used in road base construction. There are two options for surplus EoL concrete: down-cycling for elevation into the foundation layer of new buildings, or recycling into new concrete. If recycling of EoL concrete is not made mandatory through policy, the flow of EoL concrete going to new concrete will remain 600 kt/yr until 2025 (Zuidema et al., 2016), see Table 5 for parameters. In the BAU scenario, this is assumed to go through the wet process.

### 2.2.4. Concrete production and application

In 2015, 13 million  $m^3$  of ready-mixed and precast concrete was produced and consumed in the Netherlands (ERMCO, 2016). 14.1 million  $m^3$  of concrete is projected to be produced in 2025 (Zuidema et al., 2016). As mentioned in Table 2 the density of concrete is set as  $2.4 t/m^3$ , therefore the production of concrete in the Netherlands is 31,200 Kt in 2015 and 33,840 Kt in 2025. Based on the formula of concrete in Table 2, the raw materials for concrete production in 2015 and 2025 are presented in Table 6. According to the Betonhuis Cement (2019a), 55% of the annual concrete consumption is from the ready mixed concrete industry, 35% is from the precast concrete industry, and the rest 10% is from other

**Table 3**  
Scenarios definition.

Category	Description
Scenarios in 2015	<b>2015 BAU :</b> Surplus EoL concrete goes to site elevation
Scenarios in 2025	<b>2025 BAU:</b> Surplus EoL concrete goes to site elevation <b>2025 C2CA:</b> Surplus EoL concrete goes to concrete gravel manufacturing <b>2025 VEEP:</b> Surplus EoL concrete goes to concrete gravel, sand, cement manufacturing

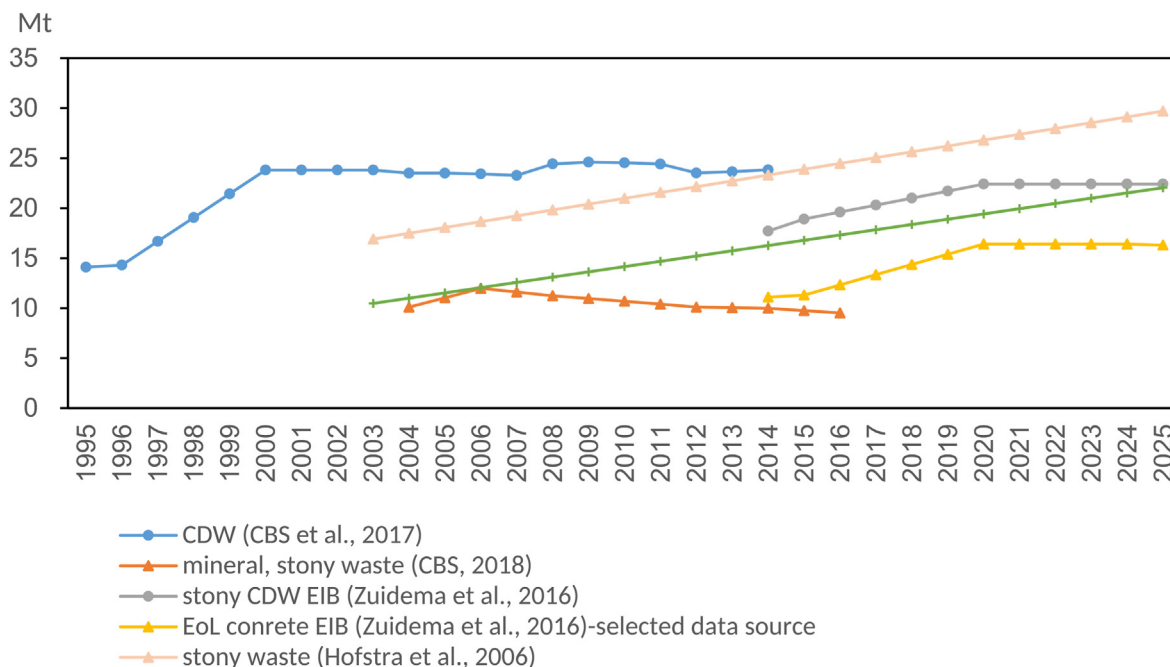

**Fig. 3.** Multiple sources of CDW generation in the Netherlands.

**Table 4**  
Sources of EoL concrete in the Netherlands.

	Residential Building	Non-Residential Building	Civil Engineering	Building Material Industry
2015	27.50%	53.00%	17.00%	2.50%
2025	31.00%	51.00%	16.00%	2.00%

Source (Hofstra et al., 2006).

**Table 5**  
Share of EoL concrete treatment in the Netherlands.

	Downcycling for foundation	Downcycling for site elevation	Recycling for new concrete manufacturing
2015	76.1%	18.6%	5.3%
2025	67.6%	28.7%	3.7%

Source: EIB's report (Zuidema et al., 2016).

**Table 6**  
Raw materials for concrete production in 2015 and 2025 (Kt).

	2015 <sup>a</sup>	2025 <sup>b</sup>
Concrete production	31,200.00	33,840.00
Gravel for concrete	14,951.04	16,216.13
Sand for concrete	9750.00	10,575.00
Cement for concrete	4548.96	4933.87
Waster for concrete	1950.00	2115.00

building material industries such as building material traders, contractors, etc. As for the application of concrete, 46.1% of the concrete in the Netherlands is supplied to the non-residential building sector, 40.4% to the residential building, and the rest 13.5% to the civil engineering sector. Detailed data can be found in [Table S2](#) of the supporting information.

### 2.2.5. Cement production and consumption

The Netherlands has only one cement producer the First Dutch Cement Industry (ENCI) BV, which has three production locations in Maastricht, Rotterdam, and IJmuiden. Although they produce a substantial fraction (46% in 2015) of the total Dutch cement consumption (Betonhuis Cement, 2019b), Dutch domestic cement production shows a decreasing trend over the time period 2006–2015 (USGS, 2018). Domestic production was 2200 Kt in 2015. We forecast it to be 1200 Kt in 2025 (see Fig. S1 in the supporting information). The balance of cement is imported from Belgium and Germany.

The net import of cement in the Netherlands in 2015 was 2574 Kt (Comtrade 2020). In the MFA model, the export of cement is accounted for as a subtraction of the import flow, and the import of cement in 2025 is a balance flow. Based on the production and net import, the total cement consumption in the Netherlands in 2015 was 4783 Kt. This volume is validated by comparing to the ERMCO report (2016) in which the total cement consumption in the Netherlands in 2015 is 4000 Kt; according to Betonhuis Cement (2019a,b) the total cement consumption in the Netherlands in 2015 is around 4250 Kt.

Concrete production consumed 4548.96 Kt of cement in 2015, accounting for 95% of total Dutch cement consumption (see Table 6). This is validated by comparing to data from Betonhuis Cement (2019b) that 85%–95% of the cement is for ready-mixed and precast concrete production in the Netherlands. We assume that 95% of cement is used for concrete production in 2025. Data on cement production, import and export is summarized in Table 7.

### 2.2.6. Aggregates production and consumption

Aggregates are mixed with cement to form concrete. The Netherlands imports part of its concrete aggregates from Germany and Belgium (Koopmans et al., 2009). Data for domestic production of aggregate from 2008 to 2017 are collected from the European Aggregates Association (UEPG 2018a). There are three categories of aggregates in the statistics of UEPG: “Sand & Gravel”, “Marine Aggregates”, and “Recycled aggregates”. As mentioned in the Goal and scope section, marine aggregates are not considered in the study.

Statistics of recycled aggregates from the UEPG includes secondary aggregates from both EoL concrete and also other stony waste. Therefore, we model the recycled aggregates instead of using UEPG data directly. According to the UEPG, 50,000 Kt of aggregates (“Sand & Gravel”) was produced in 2015 and 40,100 Kt will be produced in 2025 (see Fig. S2 of the supporting information). In the analysis, it is assumed that all domestic gravel and sand production goes to the concrete industry and the total gravel & sand production will be split based on the share of gravel (60.5%) and sand (39.5%) in concrete (by weight) in Table 2.

Regarding aggregate consumption, we calculate that 35.4% of the total gravel, and 46.1% of the total sand use in the Netherlands, was applied in concrete production in 2015. For the 2025 scenarios, the share of gravel and sand for concrete is assumed to remain 35% and 46%, respectively. This assumption seems valid because since 2013 the split in the aggregate application in Europe remains stable: 45% of aggregates go to concrete, 40% to structural material, and the remaining 15% is used in other applications such as asphalt,

railway ballast, and armor stones (UEPG, 2018b). Data on import and export of gravel and sand was collected from the UN Comtrade database (2020). Information on the aggregates production and consumption in 2015 and 2025 in the Netherlands are summarized in Table 8.

## 3. Results interpretation

### 3.1. Results

After combining the schematic model in Fig. 2 with the data presented in section 2.2, we obtain the baseline 2015 concrete cycle in the Netherlands. The Sankey diagram is shown in Fig. 4.

Sankey diagrams of 2025 BAU scenario, 2025 C2CA scenario, 2025 VEEP scenario are presented in Fig. 5, Fig. 6, and Fig. 7, respectively.

### 3.2. Interpretation

#### 3.2.1. Secondary material use in concrete

The results of our forecasts on secondary aggregate use in concrete manufacturing in the Netherlands in 2025 are summarized in Fig. 8. The 3 scenarios of the concrete cycle in the Netherlands show: if the cost of concrete recycling is more expensive than thickening foundation (as in the BAU scenarios), the secondary aggregate use in concrete industry will still remain 1% in 2025. However, the C2CA scenarios show the potential to increase the secondary gravel usage to 11% in 2025. Due to the recycling of sieve sand into recycled sand and cement, the VEEP scenario further increases the portion of secondary material used in concrete to 16%.

#### 3.2.2. Destinations of end-of-life concrete

We find that downcycling is and still will be the main outlet for EoL concrete treatment. Even in the most optimistic scenario, more than 60% of EoL concrete will be downcycled (Fig. 9). Generally, the Netherlands has eliminated landfilling of EoL concrete, with less than 1% ending up in landfills in BAU scenarios. Our BAU scenarios show that about 5% of EoL concrete will be recycled in concrete manufacturing with the rest 95% being downcycled. If the processing cost of C2CA recycling is lower than that of backfilling for site elevation, the recycling rate will possibly increase to around 20% in 2025. Furthermore, if sieve sand could be cost-effectively processed by the VEEP system, the recycling rate will increase by another 12%, compared to C2CA scenarios (see Fig. 10).

#### 3.2.3. Raw material supply

We find that the Netherlands will inevitably rely on the import of raw materials for its construction sector (see Fig. 10). Compared to 2015, the total consumption of each raw material will increase slightly in 2025. Because domestic production of gravel, sand, cement is expected to decline in 2025, the share of imports in BAU scenarios increases from 28%, 7%, and 54%, to 59%, 63%, and 77%, respectively. In the C2CA scenario, 7% of imported gravel is substituted with recycled gravel compared to BAU. The VEEP scenario finds an additional reduction of 6% virgin sand, and 7% cement. However, even with very innovative technology, there will still be a huge import of aggregates..

## 4. Policy implications

In this section, we discuss relevant policy implications in relation to currently existing policies at EU, National (Dutch), and local level.

**Table 7**

Production and consumption of cement in the Netherlands (Kt).

	2015	2025
Cement production	2200.00	1200.00
Total cement for concrete	95%	95%
Cement import	3041.52	to be balanced by STAN
Cement export	467.32	to be balanced by STAN



**Table 8**  
Gravel and sand related activities in the Netherlands in 2015 and 2025 (Kt).

Gravel and sand related activities	2015	2025
Domestic aggregates production	50,000.00	40,100.00
Domestic gravel production	30,250.00	24260.50
Domestic sand production	19,750.00	15839.50
Total gravel for concrete	35.4%	35.4%
Total sand for concrete	46.1%	46.1%
Gravel import	11952.02	to be calculated based on mass balance
Gravel export	298.58	to be calculated based on mass balance
Sand import	5258.69	to be calculated based on mass balance
Sand export	3836.36	to be calculated based on mass balance

4.1. Current policy

At EU level, there are several policy frameworks related to recovery and recycling of CDW, for example, the 7th *Environment Action Program, WFD (2008/98/EC); Roadmap to a Resource Efficient Europe (COM (2011) 571 final), Resource efficiency opportunities in the building sector (COM (2014) 445 final), Towards a circular economy: A zero waste programme for Europe (COM (2014) 398 final), and EU Construction and Demolition Waste Management Protocol, Landfill Directive (99/31/EC)*. The main policy drivers for CDW management and EoL concrete recycling are the WFD and the Landfill Directive (Bio Intelligence Service, 2011). The WFD set the 70% goal for CDW recovering for EU member states, while the Landfill Directive covers the location and technical requirements for landfills and sets targets for landfilling reductions. According to the Landfill Directive, there are three classes of landfill: hazardous waste, non-hazardous waste, and inert waste. The European List of Waste (2000/532/EC) clearly categorizes each class category of waste. However, according to the Eurostat, only the data on mineral waste recycling rate for each member state is available, thus lacking rule on verifying the compliance with the “70%” target. Additionally, the “70%” target did not mandatorily request the minimal “recycling”

(as opposed to the downcycling) target. Therefore, it is no practical significance for countries such as the Netherlands which already achieved around 100% recovery rate by downcycling on CDW but with the negligible portion on recycling.

At the national level, the national regulation corresponding to the EU WFD is the *National Waste Management Plan*. With 95%, the recycling rate for CDW in the Netherlands is already far beyond 70%, the LAP2 sets the target for CDW as keeping the current recycling rate (despite the expected increase of CDW), while reducing the overall life-cycle environmental impacts CDW management.

In the Netherlands, the process of implementation of the sustainable construction regulations (including minimization of natural resource use) is a cooperative government and industry initiative. The predominantly responsible actor(s) for the implementation of sustainable construction regulation (e.g.) are local/municipal governments (PRC, 2011). Additionally, to the aforementioned regulations, the non-legislative instrument *Green Deal* was launched by the Dutch government to support sustainable economic growth. A Green Deal is a mutual agreement or covenant under private law between a coalition of companies, civil society organizations and local and regional governments. Since 2011,

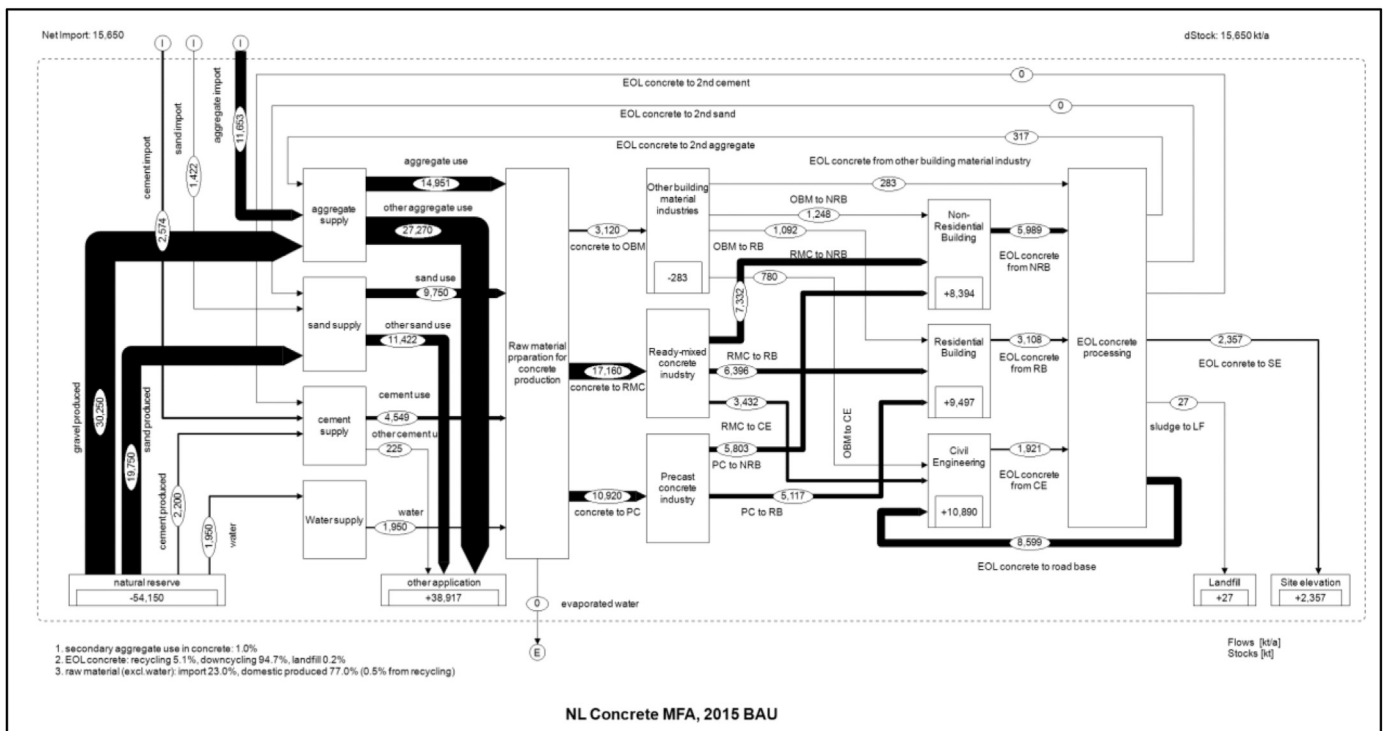

Fig. 4. Quantified concrete cycle in the Netherlands in the 2015 BAU scenario. Note: numbers in Kt.

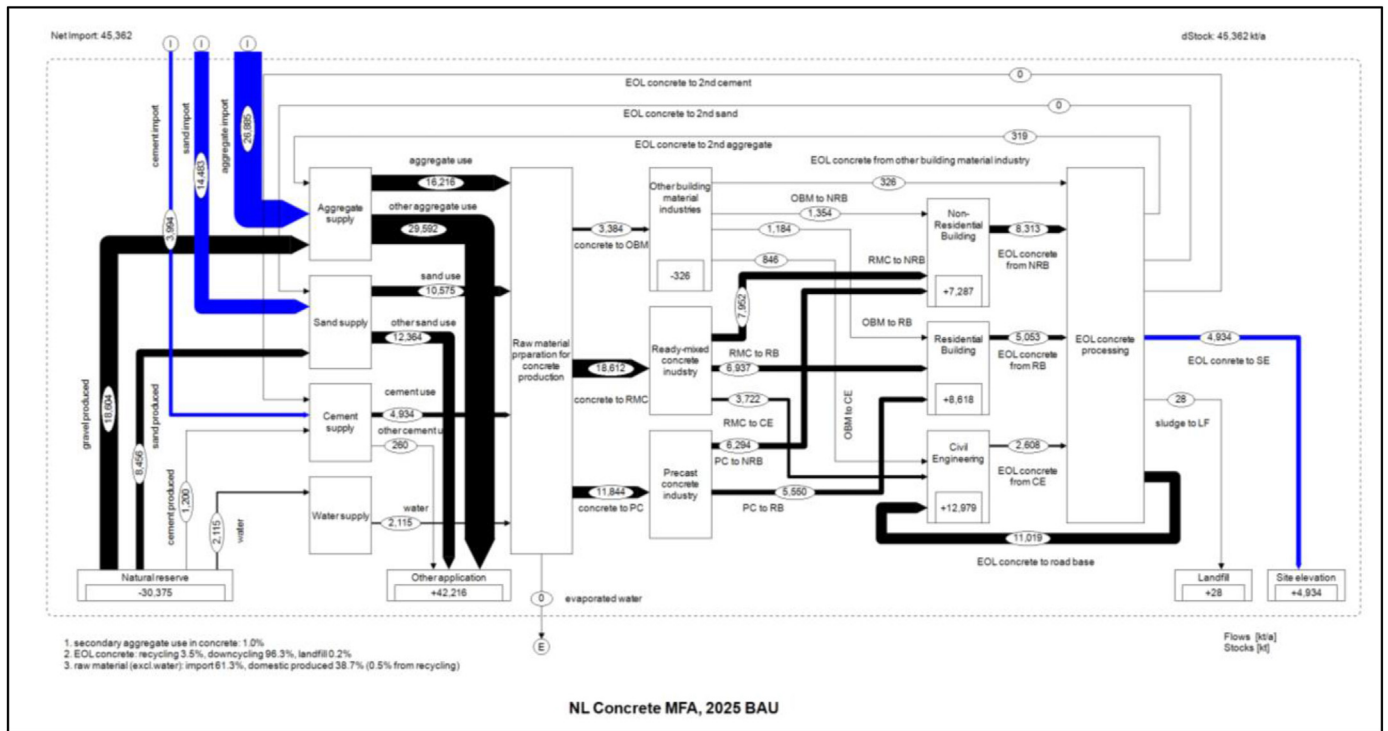

Fig. 5. Concrete cycle in the Netherlands: 2025 BAU scenario. Note: numbers in Kt; flows balanced by STAN are colored blue. (For interpretation of the references to color in this figure legend, the reader is referred to the Web version of this article.)

more than 200 Green Deals have been signed. For the concrete sector, Green Deal 030 was completed in 2016, aiming to substantially reduce CO<sub>2</sub> emissions and achieve high-quality recycling of concrete by 2030.

**At the local level**, the main approach to stimulate concrete recycling is through Sustainable Public Procurement. The Dutch government has developed a set of sustainability criteria documents. These contain recommendations that public authorities can

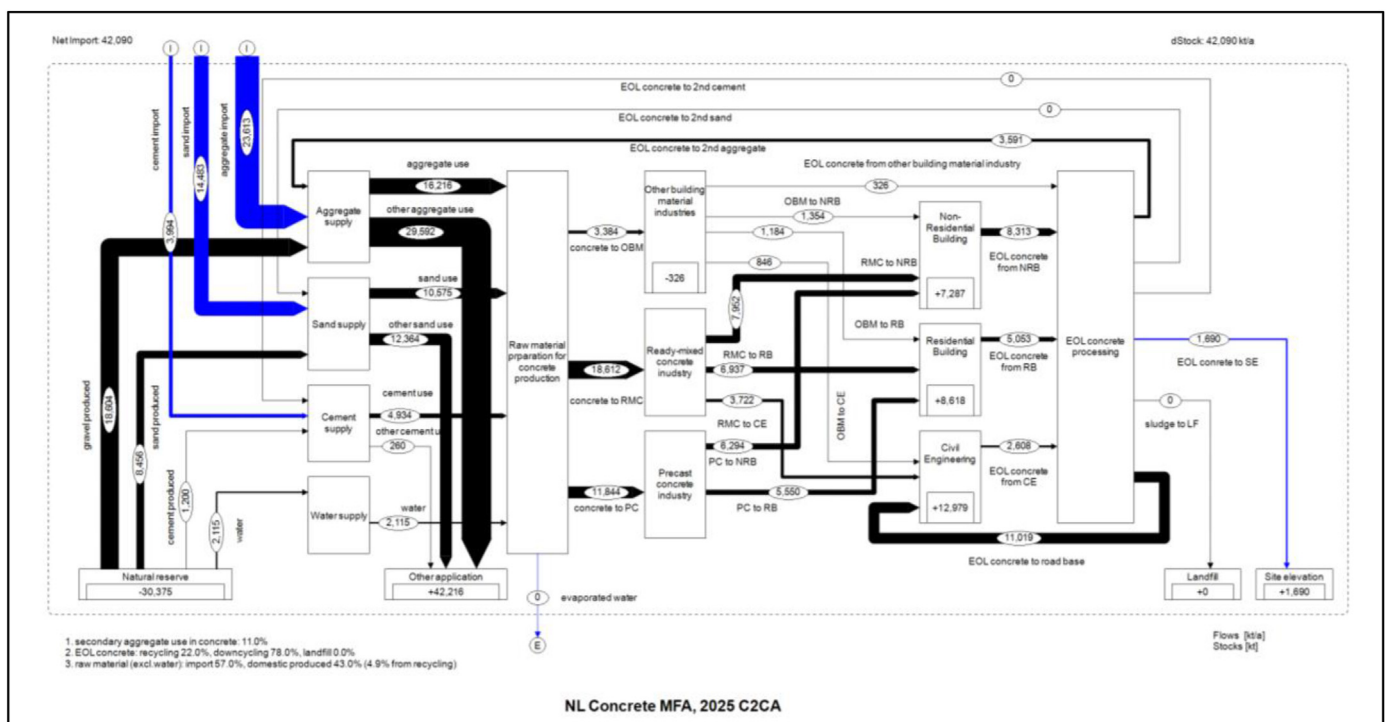

Fig. 6. Concrete cycle in the Netherlands: 2025 C2CA scenario. Note: numbers in Kt; flows balanced by STAN are colored blue. (For interpretation of the references to color in this figure legend, the reader is referred to the Web version of this article.)

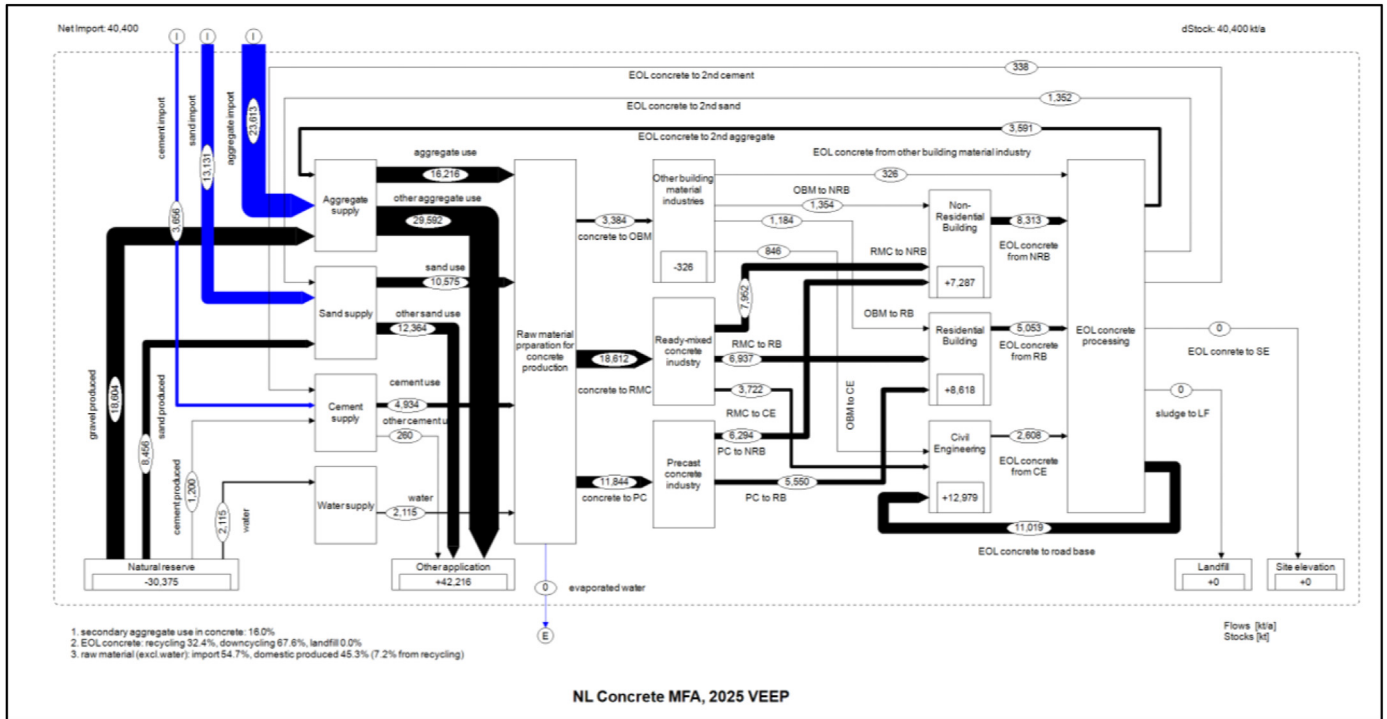

Fig. 7. Concrete cycle in the Netherlands: 2025 VEEP scenario. Note: numbers in Kt; flows balanced by STAN are colored blue. (For interpretation of the references to color in this figure legend, the reader is referred to the Web version of this article.)

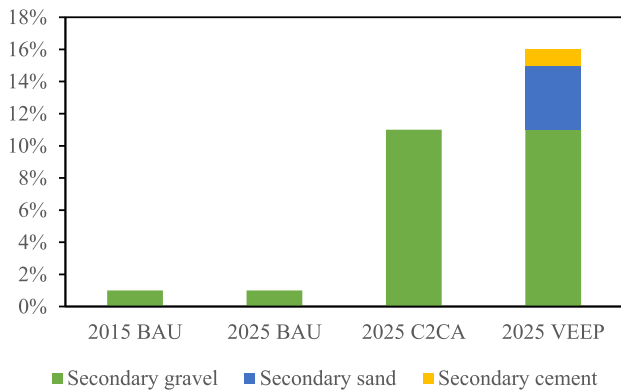

Fig. 8. Secondary aggregate usage in concrete manufacturing in the Netherlands. Note: the vertical axis indicates shares of secondary material used in concrete manufacturing by weight, and the horizontal axis indicates four scenarios.

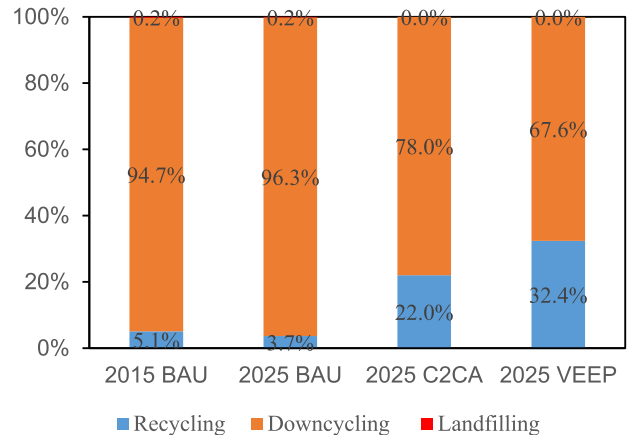
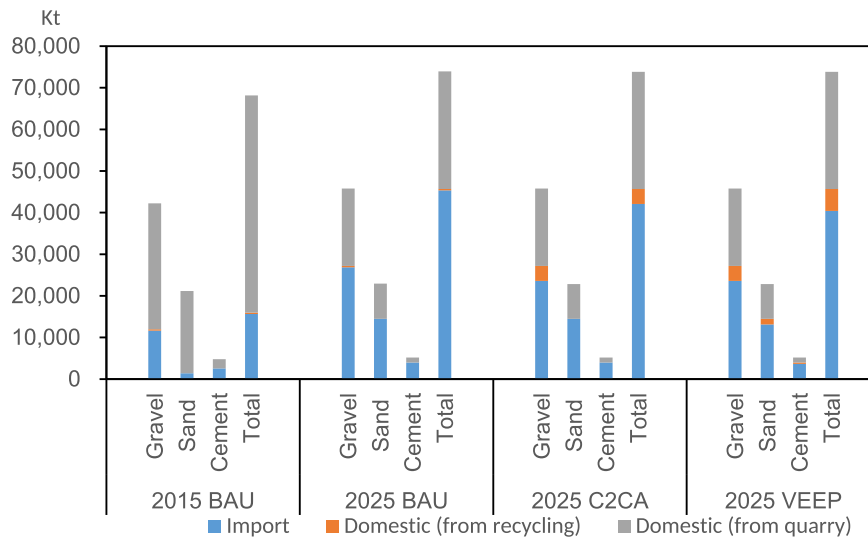

Fig. 9. Destinations of End-of-life Concrete in the Netherlands in 2025. Note: 1) the vertical axis indicates the shares of EoL concrete disposed by recycling, downcycling, and landfilling; the horizontal axis indicates the scenarios; 2) the “recycling” means EoL concrete is recovered for concrete manufacturing; 3) the “downcycling” means EoL concrete is recovered for road base and building foundation construction; 4) the “landfilling” means a very few portion of sludge from the wet process in BAU scenario is disposed through landfilling.

use to implement sustainable procurement practices for approximately 45 products, services and public works. Most relevant to the recycling of EoL concrete is the *Criteria for the Sustainable Public Procurement of Demolition of Buildings*, which set up minimum requirements on the demolition process and stony waste breaking-up process. The *Criteria for the sustainable procurement of Construction Works* addresses the use of secondary materials as a point for consideration at the preparatory stage at the procurement process. The core Sustainable Public Procurement criteria require the contractor to put appropriate measures in place to reduce and recover (reuse or recycle) waste that is produced during the demolition and construction process.

The Dutch governmental authorities have also set clear objectives to boost the market for Sustainable Public Products: the

municipalities are aiming for 75% sustainable public procurement in 2010 and 100% in 2015. Provincial governments and water boards have set themselves the target of at least 50% in 2010. (While the central government aspires towards 100% Sustainable Public Procurement in 2010). 100% Sustainable Public Procurement is understood to mean that all purchases meet the minimum requirements that have been set for the relevant product groups at the time of purchase. However, no mandatory requirement exists on the minimum use of recycled gravel, recycled sand, and recycled cementitious particle.



**Fig. 10.** Raw material supply in the Netherlands in 2015 and 2025. Note: the vertical axis indicates the sources of each raw material consumed in the Netherlands, and the horizontal axis indicates raw material in each scenario.

#### 4.2. Potential policy options

Below we discuss the main gaps between the policy goals and current practices in Dutch concrete recycling, as well as several potential policy options.

We start with the EU level, where the general high-level recycling goals are set. For countries such as the Netherlands, which are supposed to shift from downcycling to recycling, the EU should set more ambitious goals. For example, the goal could be set as “those member states who already achieved the goal of recovering 70% CDW, are encouraged to achieve a 20% recycling goal”.

Setting more ambitious goals at the EU level is only possible if a clear definition of recycling (as opposed to downcycling, or energy recovery) is given, which is currently lacking. Waste registration systems of member states not harmonized. For example, the 98% recycling rate of Dutch CDW includes energy recovery. Furthermore, the definition of “backfilling” should be strictly clarified in order to avoid “hiding” landfilling operations in this definition.

Unfortunately, current waste registration systems and databases are not suitable for estimating EoL flows of CDW, and in particular concrete. It is, therefore, necessary to develop a more systematic waste registration system which includes quantities CDW is generated, and how it is treated. Given more detailed information about CDW management, more precise decisions could be made by national governments.

At the Dutch level, concrete is mainly downcycled instead of recycled. Recycling of CDW has the potential to mitigate environmental impact compared to downcycling, but in current policy, there is no direct link between recycling targets and environmental targets. Development of standardized Life Cycle Assessment-based tools for assessing the options can support environmental performance-based policy making for EoL concrete recycling. In the short term, a minimum high-quality recycling share should be set regarding EoL concrete recovery in the upcoming National concrete Agreement.

At the local level, Sustainable Public Procurement is a strong potential driver for CDW recycling, but it does not provide mandatory requirements on the minimum use of recycled materials. Guidelines and regulations often consider the physical

limitations of recycled concrete aggregate. The C2CA and VEEP projects have demonstrated that with proper quality control of secondary material, the recycled aggregate concrete will not be noticeably different in terms of workability and strength, compared with concrete with natural aggregate. Therefore a minimum required share of recycled aggregates and cement should be introduced in Sustainable Public Procurement criteria. Based on the current work, we propose that the minimum required share to be set at 5–20%.

#### 5. Conclusion

Construction and Demolition Waste is one of the largest solid waste streams in the world. Urban mining of CDW is an important solution for minimizing the volume of waste in the urban built environment. Based on a regional scale MFA, this paper explores the consequences of moving EoL concrete – one of the most significant fractions of CDW – from conventional downcycling towards true recycling.

Our main findings are as follows: Firstly, our business-as-usual scenario shows that if current recycling technology is not further developed, the use of secondary aggregates in Dutch concrete manufacturing will remain at a low level of 1%. By implementing cost-effective and innovative recycling technologies, the use of secondary aggregates can increase to 11%–16%. Secondly, the Dutch recycling rate of CDW can improve from the current 5% to up to 21%–32%. Finally, we find that – due to declining domestic production – a lack of innovation will push the net import of gravel, sand, and cement up to 59%, 63%, and 77%, respectively. Large-scale implementation of the C2CA technology may reduce the import rate of gravel down to 52%; additionally, the VEEP technologies have the potential to reduce import rate of sand and cement down to 57% and 70%. Even through with very innovative technology, more than half of the supply on those raw materials will still rely on imports.

Based on the findings, the potential policy options to upgrade the downcycling of CDW toward recycling were discussed from EU, national, and local levels.

This study knows three main limitations. First, a universal

problem for all material flow analyses is data availability, which is especially pressing for the waste sector. This affects the quality and quantity of outputs. We employed simple computation to obtain missing data, validated by comparison to other literature. However, future research would benefit from more precise mathematic modeling to project future material flows. Second, by using a “semi-dynamic” MFA model this study is confined to explore the concrete cycle in a rather near future (until 2025) in the Netherlands. It is still unclear about those scenarios in which road construction is saturated and a large amount of EoL concrete has to be recycled for concrete manufacturing in much further future. Third, this study did not explore the environmental, economic, and even social impacts of the upgraded EoL concrete management. Combining MFA with other assessment methods, such as life cycle assessment, or environmental life cycle costing, would provide valuable insights for CDW management.

## Acknowledgment

The authors thank the support from the European Commission Seventh Framework Project C2CA project “Advanced Technologies for the Production of Cement and Clean Aggregates from Construction and Demolition Waste” (No.265189), and European Commission H2020 Project VEEP “Cost-Effective Recycling of C&DW in High Added Value Energy Efficient Prefabricated Concrete Components for Massive Retrofitting of our Built Environment” (No. 723582). The first author thanks the financial support from the China Scholarship Council (201706050090).

## Appendix A. Supplementary data

Supplementary data to this article can be found online at <https://doi.org/10.1016/j.jclepro.2020.121718>.

## References

- Allwood, J.M., 2014. Squaring the circular economy. In: *Handbook of Recycling*. Elsevier, pp. 445–477. <https://doi.org/10.1016/B978-0-12-396459-5.00030-1>.
- Andr, R., Brattek, H., 2016. Projection of construction and demolition waste in Norway. *J. Ind. Ecol.* 11, 27–39.
- Bio Intelligence Service, 2011. Service contract on management of construction and demolition waste – SR1, final report task 2. European commission (DG ENV) ENV.G.4/FRA/2008/0112.
- CBS, 2018. Delivery, processing of waste at recycling companies (SBI2008) [WWW Document]. URL <https://opendata.cbs.nl/statline/#/CBS/nl/dataset/81416ned/table?ts=1572535193296>. . accessed 11.4.19.
- CBS, Pbl, Rivm, Wur, 2017. Construction and demolition waste: release and processing, 1985–2014 (indicator 0147, version 10, 1 June 2017). [www.clo.nl](http://www.clo.nl). Central Bureau of Statistics (CBS), The Hague; PBL Netherlands Environmental Assessment Agency, The Hague; RIVM National Institute [WWW Document]. <https://www.clo.nl/indicatoren/nl0147-bouw-en-sloopafval>. accessed 11.4.19.
- Cement, Betonhuis, 2019a. Concrete market [WWW document]. URL <http://www.cementenbeton.nl/marktinformatie/betonmarkt>. accessed 11.6.19.
- Cement, Betonhuis, 2019b. Cement market information in The Netherlands [WWW Document]. URL <http://www.cementenbeton.nl/marktinformatie/cementmarkt>. . accessed 11.6.19.
- Cencic, O., Rechberger, H., 2008. Material flow analysis with software STAN. In: *EnviroInfo 2008 - Environmental Informatics and Industrial Ecology*. Lüneburg, pp. 440–447.
- Cochran, K., Townsend, T., Reinhart, D., Heck, H., 2007. Estimation of regional building-related C&D debris generation and composition: case study for Florida, US. *Waste Manag.* 27, 921–931. <https://doi.org/10.1016/j.wasman.2006.03.023>.
- Di Maria, A., Eyckmans, J., Van Acker, K., 2018. Downcycling versus recycling of construction and demolition waste: combining LCA and LCC to support sustainable policy making. *Waste Manag.* 75, 3–21. <https://doi.org/10.1016/j.wasman.2018.01.028>.
- Dong, B., Wang, J., Wu, H., Song, Q., Zheng, L., Jiang, W., Zuo, J., Liu, G., Duan, H., Zhang, H., 2017. Characterizing the generation and flows of construction and demolition waste in China. *Construct. Build. Mater.* 136, 405–413. <https://doi.org/10.1016/j.conbuildmat.2017.01.055>.
- Ec, 2008. Waste framework directive: directive 2008/98/EC of the European parliament and of the Council of 19 november 2008 on waste and repealing certain directives (text with EEA relevance) [WWW document]. URL [eur-lex.europa.eu/legal-content/EN/TXT/?uri=CELEX:32008L0098](https://eur-lex.europa.eu/legal-content/EN/TXT/?uri=CELEX:32008L0098). accessed 4.13.18.
- Ec, 2018. Construction and demolition waste (CDW) [WWW document]. URL [http://ec.europa.eu/environment/waste/construction\\_demolition.htm](http://ec.europa.eu/environment/waste/construction_demolition.htm). . accessed 3.1.20.
- Ermco, 2016. Ready-mixed concrete industrial statistics: 2004–2015.
- Eurostat, 2018. Circular economic indicators-Recovery rate of construction and demolition waste [WWW Document]. URL [https://ec.europa.eu/eurostat/tgm/table.do?tab=table&init=1&language=en&pcode=cei\\_wm040&plugin=1](https://ec.europa.eu/eurostat/tgm/table.do?tab=table&init=1&language=en&pcode=cei_wm040&plugin=1). . accessed 12.14.18.
- Gálvez-Martos, J.L., Styles, D., Schoenberger, H., Zeschmar-Lahl, B., 2018. Construction and demolition waste best management practice in Europe. *Resour. Conserv. Recycl.* 136, 166–178. <https://doi.org/10.1016/j.resconrec.2018.04.016>.
- Hofstra, U., van Bree, B., de Wildt, R., Neele, J., 2006. *Scenariostudie BSA--Granulaten: aanbod en afzet van 2005 tot 2025*.
- Hu, M., Kleijn, R., Bozhilova-Kisheva, K.P., Di Maio, F., 2013. An approach to LCSA: the case of concrete recycling. *Int. J. Life Cycle Assess.* 18 (9), 1793–1830. <https://doi.org/10.1007/s11367-013-0599-8>.
- Kartam, N., Al-Mutairi, N., Al-Ghusain, I., Al-Humoud, J., 2004. Environmental management of construction and demolition waste in Kuwait. *Waste Manag.* 24, 1049–1059. <https://doi.org/10.1016/j.wasman.2004.06.003>.
- Koffler, C., Florin, J., 2013. Tackling the downcycling issue - a revised approach to value-corrected substitution in life cycle assessment of aluminum (VCS 2.0). *Sustain.* <https://doi.org/10.3390/su5114546>.
- Koopmans, T.P.F., Senden, M.A., Faas, R., 2009. *Productie en verbruik van beton-en metselzand en (gebroken) grind in 2008*.
- Koutamian, A., van Reijn, B., van Bueren, E., 2018. Urban mining and buildings: a review of possibilities and limitations. *Resour. Conserv. Recycl.* 138, 32–39. <https://doi.org/10.1016/j.resconrec.2018.06.024>.
- Mália, M., De Brito, J., Pinheiro, M.D., Bravo, M., 2013. Construction and demolition waste indicators. *Waste Manag. Res.* 31, 241–255. <https://doi.org/10.1177/0734242X12471707>.
- Martínez Lage, I., Martínez Abella, F., Herrero, C.V., Ordóñez, J.L.P., 2013. Estimation of the annual production and composition of C&D Debris in Galicia (Spain). *Waste Manag.* 30, 636–645. <https://doi.org/10.1016/j.wasman.2009.11.016>.
- Monier, V., Hestin, M., Impériale, A.-C., Hobbs, G., Adams, K., Pairen, M., Winghe, M.R., de Wiaux, F., Gaillot, O., Wahlström, M., Ramos, M., 2017. Resource efficient use of mixed wastes:improving management of construction and demolition waste.
- Mulders, L., 2013. *High Quality Recycling of Construction and Demolition Waste in the Netherlands*. Utrecht University.
- Office of Resource Conservation and Recovery, 2018. *Construction and demolition debris generation in the United States in 2015*.
- Prc, 2011. *The lead market initiative and sustainable construction: lot 1, screening of national building regulations (final report)*.
- Purnell, P., Dunster, A., 2010. Recycling of concrete. In: *Management, Recycling and Reuse of Waste Composites*. Elsevier, pp. 569–591. <https://doi.org/10.1533/9781845697662.5.569>.
- Seigné-Ittoiz, E., Gasol, C.M., Rieradevall, J., Gabarrell, X., 2015. Methodology of supporting decision-making of waste management with material flow analysis (MFA) and consequential life cycle assessment (CLCA): case study of waste paper recycling. *J. Clean. Prod.* 105, 253–262. <https://doi.org/10.1016/j.jclepro.2014.07.026>.
- Uepp, 2018a. Estimates of aggregates production data [WWW Document]. URL <http://www.uepp.eu/statistics/estimates-of-production-data>. accessed 4.29.19.
- Uepp, 2018b. *European aggregates association annual review:2013–2018*.
- Un Comtrade database, 2020. *Commodities import and export in The Netherlands* [WWW Document]. URL <https://comtrade.un.org/data/>. . accessed 4.12.20.
- Usgs, 2018. *Cement statistics and information* [WWW Document]. URL <https://minerals.usgs.gov/minerals/pubs/commodity/cement/index.html>. . accessed 4.29.19.
- van der Voet, E., 1996. *Substances from Cradle to Grave: Development of a Methodology for the Analysis of Substance Flows through the Economy and the Environment of a Region*. Leiden University.
- Vrom, 2008. *National waste management plan (LAP) 2009–2021:towards a material chain policy*. Den Haag.
- Wang, W., Jiang, D., Chen, D., Chen, Z., Zhou, W., Zhu, B., 2016. A Material Flow Analysis (MFA)-based potential analysis of eco-efficiency indicators of China's cement and cement-based materials industry. *J. Clean. Prod.* 112, 787–796. <https://doi.org/10.1016/j.jclepro.2015.06.103>.
- Zhang, C., Hu, M., Dong, L., Xiang, P., Zhang, Q., Wu, J., Li, B., Shi, S., 2018. Co-benefits of urban concrete recycling on the mitigation of greenhouse gas emissions and land use change: a case in Chongqing metropolis, China. *J. Clean. Prod.* 201, 481–498. <https://doi.org/10.1016/j.jclepro.2018.07.238>.
- Zhang, C., Hu, M., Dong, L., Gebremariam, A., Miranda-Xicotencatl, B., Di Maio, F., Tukker, A., 2019. Eco-efficiency assessment of technological innovations in high-grade concrete recycling. *Resour. Conserv. Recycl.* 149, 649–663. <https://doi.org/10.1016/j.resconrec.2019.06.023>.
- Zhang, C., Hu, M., Yang, X., Amati, A., Tukker, A., 2020. Life cycle greenhouse gas emission and cost analysis of prefabricated concrete building façade elements. *J. Ind. Ecol.* <https://doi.org/10.1111/jiec.12991>. In press.
- Zuidema, M., Saitua, R., Smit, N., 2016. *Macroeconomic Exploration Concrete Agreement (In Dutch: Macro-Economische Verkenning Betonakkoord)* (Netherlands: Amsterdam).