



Universiteit
Leiden
The Netherlands

Does the temporal cortex make us human? A review of structural and functional diversity of the primate temporal lobe

Braunsdorf, M.; Blazquez Freches, G.; Roumazeilles, L.; Eichert, N.; Schurz, M.; Uithol, S. et al.

Citation

Braunsdorf, M., Blazquez Freches, G., Roumazeilles, L., Eichert, N., Schurz, M., & Uithol, S. et al. (2021). Does the temporal cortex make us human?: A review of structural and functional diversity of the primate temporal lobe. *Neuroscience & Biobehavioral Reviews*, 131, 400-410. doi:10.1016/j.neubiorev.2021.08.032

Version: Publisher's Version

License: [Creative Commons CC BY 4.0 license](https://creativecommons.org/licenses/by/4.0/)

Downloaded from: <https://hdl.handle.net/1887/3245495>

Note: To cite this publication please use the final published version (if applicable).



Review article

Does the temporal cortex make us human? A review of structural and functional diversity of the primate temporal lobe

Marius Braunsdorf^{a,*}, Guilherme Blazquez Freches^a, Lea Roumazeilles^b, Nicole Eichert^c, Matthias Schurz^{a,d}, Sebo Uithol^a, Katherine L. Bryant^c, Rogier B. Mars^{a,c}

^a Donders Institute for Brain Cognition and Behaviour, Radboud University Nijmegen, Nijmegen, the Netherlands

^b Wellcome Centre for Integrative Neuroimaging, Department of Experimental Psychology, University of Oxford, Oxford, United Kingdom

^c Wellcome Centre for Integrative Neuroimaging, Centre for Functional MRI of the Brain (FMRIB), Nuffield Department of Clinical Neurosciences, John Radcliffe Hospital, University of Oxford, Oxford, United Kingdom

^d Institute of Psychology, University of Innsbruck, Innsbruck, Austria



ARTICLE INFO

Keywords:

Evolutionary neuroscience
Comparative
Temporal cortex
Human
Macaque
Theory of mind

A B S T R A C T

Temporal cortex is a primate specialization that shows considerable variation in size, morphology, and connectivity across species. Human temporal cortex is involved in many behaviors that are considered especially well developed in humans, including semantic processing, language, and theory of mind. Here, we ask whether the involvement of temporal cortex in these behaviors can be explained in the context of the ‘general’ primate organization of the temporal lobe or whether the human temporal lobe contains unique specializations indicative of a ‘step change’ in the lineage leading to modern humans. We propose that many human behaviors can be explained as elaborations of temporal cortex functions observed in other primates. However, changes in temporal lobe white matter suggest increased integration of information within temporal cortex and between posterior temporal cortex and other association areas, which likely enable behaviors not possible in other species.

1. Introduction

The temporal lobe forms a large part of primate association cortex. It is considered to have evolved early in primate evolution (Allman, 1982) and to be distinct from lateral expansions seen in other mammalian orders, such as those in Proboscidea (elephants), Cetacea (aquatic mammals), and Carnivora (Bryant and Preuss, 2018). A large part of the temporal lobe is devoted to unimodal visual association cortex, which many authors have linked to primates’ specialization as visual foragers (Mars and Bryant, 2021; Murray et al., 2017).

The temporal lobe is involved in many high-level cognitive functions that are particularly well developed in humans. These include conceptual categorization, semantic and language processing (Spitsyna et al., 2006; Garcin et al., 2018) and social information processing, including the ability to mentalize or attribute beliefs to others (Schurz et al., 2020). The search for the neural basis of such human abilities traditionally focused on the human prefrontal cortex. Some authors have emphasized on a purportedly disproportional expansion of human prefrontal cortex (Deacon, 1997). Others proposed a more detailed account of human prefrontal cortex specializations within the framework of

anthropoid brain evolution (Passingham and Wise, 2012). Although more recent works also highlight potential changes in precuneus and inferior parietal cortex (Van Essen and Dierker, 2007; Bruner, 2018), whole-brain comparisons of human and non-human primate brains showed the temporal lobe to be a major hotspot of expansion and reorganization (Van Essen and Dierker, 2007; Mars et al., 2018b), suggesting this part of cortex warrants more attention in a comparative perspective.

This raises the question of how ‘uniquely human’ temporal lobe functions have emerged from its anatomy in the human lineage. For argument’s sake, one can envision two extreme positions: The first is that human temporal lobe is simply a variation and elaboration of the non-human primate scheme. Such a position is similar to that taken by some in the debate on the number of neurons in the human neocortex. The number of neurons in humans is as expected for their brain size, in other words, humans are a continuation of an existing trend amongst primates (Herculano-Houzel, 2012). The alternative position is that human temporal lobe has undergone substantial change that fundamentally altered its organization and hence its abilities. Such a position is consistent with proposed step changes in human abilities, when a new

* Corresponding author at: Montessorilaan 3, 6525 HR, Nijmegen, the Netherlands.

E-mail address: m.braunsdorf@donders.ru.nl (M. Braunsdorf).

<https://doi.org/10.1016/j.neubiorev.2021.08.032>

Received 1 February 2021; Received in revised form 3 August 2021; Accepted 30 August 2021

Available online 1 September 2021

0149-7634/© 2021 The Authors. Published by Elsevier Ltd. This is an open access article under the CC BY license (<http://creativecommons.org/licenses/by/4.0/>).

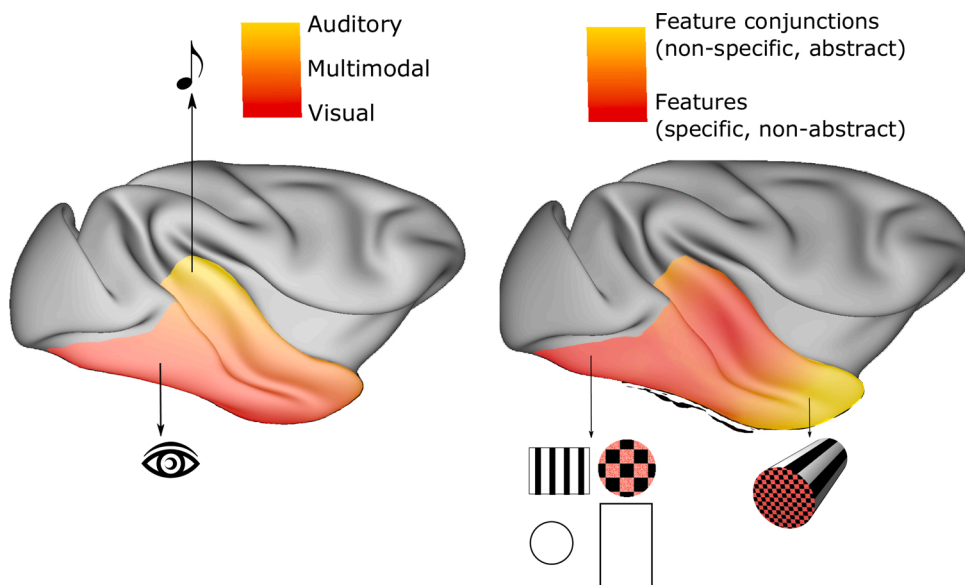

Fig. 1. Organizing principles of the macaque temporal lobe. (A) First organizational principle showing processing of visual information ventrally ranging to auditory information dorsally. (B) Second organization principle, showing increasing integration of features towards extreme values on the anterior end. As a purely visual example for processing of complex stimuli, posteriorly in the ventral visual stream we observe coding of single features, while more anteriorly we observe coding of increasingly complex feature conjunctions. The principles of organization in this figure are a purely schematic representation of information flow in the temporal lobe.

behavior suddenly appears in the fossil record, such as the cultural explosion that occurred around 60,000 years ago and that some authors have suggested to be potentially be due to a single or very few changes in brain organization (Klein, 2009).

Arbitration between these extreme positions is hindered by the scarcity of overarching theories on temporal lobe organization and lack of comparative studies focusing on this part of the brain. Here, we synthesize the current state of knowledge on variation in temporal lobe structure and function across the primate order. We start by proposing a simple organizational scheme of temporal lobe organization based on the macaque, the most commonly studied non-human primate. We then explore the variation of temporal lobe organization and temporal lobe function across species. Finally, we conclude by exploring how those variations across species help understand the role of the temporal lobe in human behavior.

2. The macaque temporal lobe

Surprisingly, there are only few overarching schemes of temporal lobe organization. This might be because the temporal lobe houses many constituent parts of interest to different sub-disciplines of researchers. Indeed, more specialized overviews focusing on particular functions such as vision, memory, semantics, and language are available (Binder and Desai, 2011; Friederici, 2011; Leopold et al., 2017; Conway, 2018). As a starting point, we here present a simplistic model of the temporal lobe. We first focus on the macaque, given its prominent role in comparative neuroscience and the vast amount of data available on this species. Although macaques and humans diverged about 29 million years ago (Kumar et al., 2017) and the macaque cannot be taken as a representative of the last common ancestor of the human, the fact that the macaque is the traditionally most studied non-human primate makes it an appropriate starting point. This relatively well-understood species will thus serve as an archetype to which modifications in different lineages can be discussed, without making statements about ancestry.

One can synthesize the diverse literature on the macaque temporal lobe in an admittedly simplified scheme (Fig. 1) describing two organizational principles of temporal cortex. The first principle (Fig. 1A) runs ventral-dorsal, from the predominantly visual inferior temporal cortex to the auditory areas of the superior temporal gyrus. The second principle (Fig. 1B) reflects the increasing abstraction of the processed information with decreasing specificity and increasing generality of representations, either for visual information when moving anteriorly

along the inferior part of the temporal cortex or running outwards from the primary auditory cortex for auditory information. In this section, we explore how this scheme captures some of the diverse aspects of temporal lobe anatomy and function in the macaque.

Starting at the ventral aspect of the first principle, the inferior temporal cortex receives strong inputs from the primary visual system and forms the ventral visual stream that is heavily involved in visual object perception (Mishkin et al., 1983; Kravitz et al., 2013). This stream consists of the territory ventral to the superior temporal sulcus. When moving anteriorly along the ventral visual stream, i.e. following our second principle, the receptive fields of neurons increase, the stimulus features processed get more complex, and neural responses get more invariant to visual transformations. Along the ventral stream, neurons code progressively more complex, fine-grained conjunctions of features, features of features, and finally whole objects. Within the ventral temporal cortex, there is evident clustering of response profiles with selectivity for particular object categories. The phylogenetic and ontogenetic basis of such selectivity remains a topic of debate, but an interaction between phylogenetic constraint and visual experience is likely (Srihasam et al., 2012). Although often described as a visual hierarchy, it is now well accepted that the connections along this stream are reciprocal and heavily interconnected with perirhinal cortex and subcortical areas. Moreover, the view of a single ventral pathway is outdated, with more recent proposals emphasizing the existence of multiple ventral pathways, perhaps coding information of different aspects of the visual field (Kravitz et al., 2013). Response profiles in anterior temporal cortex are highly adaptable, showing categorical distinctions between stimuli after little training (Kobatake et al., 1998; Kiani et al., 2007).

Murray and colleagues (2017) argue that the view of inferior temporal cortex serving purely as object identifier is outdated and propose a more evolutionary plausible function for temporal cortex: that of coding goal-related feature conjunctions for use in a foraging context. This view emphasizes the diurnal foraging habitat to which anthropoid primates adapted, where distant qualitative attributes became important to recognize. As such, temporal cortex provides contextual information to other parts of the brain, including frontal cortex, to reduce foraging errors. This hypothesis renders the temporal cortex as highly adapted for processing complex information for the foraging niche of primates. This proposed 'preparatory' role in creating feature conjunctions of complex entities or events is underlined by results from a visual categorization experiment by Freedman and colleagues (2003). They taught monkeys to group visual stimuli as 'cats' or 'dogs'. Within inferior temporal

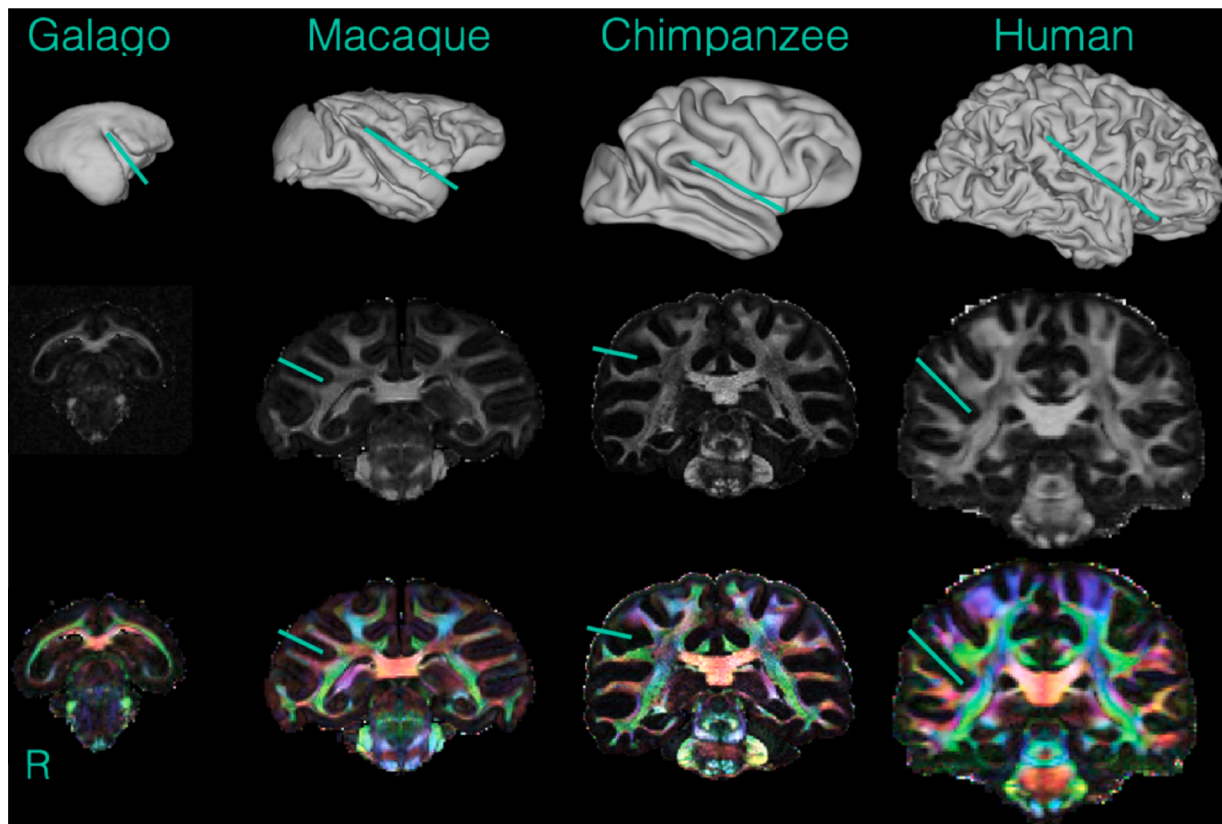

Fig. 2. Variation in temporal lobe morphology across species. Surface view, FA maps displaying grey (darker color) and white matter (lighter color), and primary diffusion directions (color indicates direction: red = left/right, blue = dorsal/ventral, green = anterior/posterior) in four primates from different branches of the primate phylogenetic tree. Data from [Bryant et al. \(2021\)](#). Brains not to scale.

cortex, neurons were able to distinguish between categories, but mostly in the context of rapid visual analysis of the visual stimuli. In contrast, neurons in dorsal prefrontal cortex showed categorization signals at more behaviorally relevant moments and stronger modulation related to the response status of the stimulus.

In the most dorsal part of the first organizational principle, the superior temporal gyrus houses areas devoted to auditory processing that receive input from the medial geniculate complex. The auditory areas are often described in terms of a hierarchically organized system of core, belt, and parabelt ([Kaas and Hackett, 2000](#)). The core areas, including the primary auditory cortex, contain tonotopically organized areas and lesions to them impair sound detection. In contrast, lesions to the belt and parabelt lead to deficits in auditory pattern detection, consistent with the notion of a functional hierarchy. In addition, neuronal firing patterns in belt areas suggest an increased sensitivity to a wider range of frequencies compared to primary auditory areas, implying a convergence of information from core areas. Thus, as in the visual system, there is an increasing abstraction when moving away from primary areas to more unimodal association areas, consistent with the second organizational principle. Belt areas in both anterior and posterior parts of the temporal cortex display an own species bias marked by stronger responses to species-specific vocalizations ([Petkov et al., 2009](#)). Connections from predominantly the parabelt to the rest of the brain enable integration with information from other modalities processed in temporal, parietal, and frontal cortex. The connections from the auditory cortex to the rest of the brain form two pathways, analogous to the two visual pathways: a ‘what’ pathway involving anterior temporal and ventral prefrontal regions and a ‘where’ or ‘how-to’ pathway involving parietal and dorsal frontal cortex ([Kaas and Hackett, 1999](#); [Rauschecker and Scott, 2009](#)). Overall, the functional organization of temporal cortex in processing auditory information is compatible with the evolutionary

perspective presented above for the visual stream, with temporal cortex processing sensory information originating from distant sources.

Apart from their foraging life, primates are also characterized by their high sociality ([Dunbar and Schultz, 2007](#)). This sociality is largely mediated by the visual and auditory systems that serve well to communicate across large distances ([Dobson, 2009](#)). The visual system contains specialized face processing clusters ([Tsao et al., 2003](#); [Ku et al., 2011](#)). In accordance with the second organizational principle, position and head orientation invariance increases in more anterior regions, helping to establish facial identity. However, identity is not the only crucial information one needs to obtain from a face when navigating in social life. Indeed, neurons in some face clusters in superior temporal sulcus represent the direction of attention of another person, whether available from eyes, faces, or even body posture ([Perrett et al., 1992](#)). Some researchers have described the characteristics of face-sensitive areas in temporal cortex matching our two principles described above ([Yovel and Freiwald, 2013](#)). According to this model, while ventral areas code for static facial features such as those helping establish identity, areas in the dorsal aspect of temporal cortex respond to changing aspects of faces. In addition, in both ventral and dorsal parts of inferior temporal cortex, the size of receptive fields increases when moving anteriorly, in particular for those fields coding for increasingly abstract features of faces (e.g. gaze-direction or expression). Auditory information processing in the dorsal temporal cortex also shows specializations for social stimuli, with coding of conspecific vocalizations evident in the ventral auditory stream ([Fukushima et al., 2014](#)). Thus, the macaque visual and auditory association cortex both contain specialized areas whose functions preferentially aid social information processing.

Processing along the two principles of organization as described here and communication with the rest of the brain is mediated by the major fiber bundles terminating in the temporal cortex. Many of the long-range

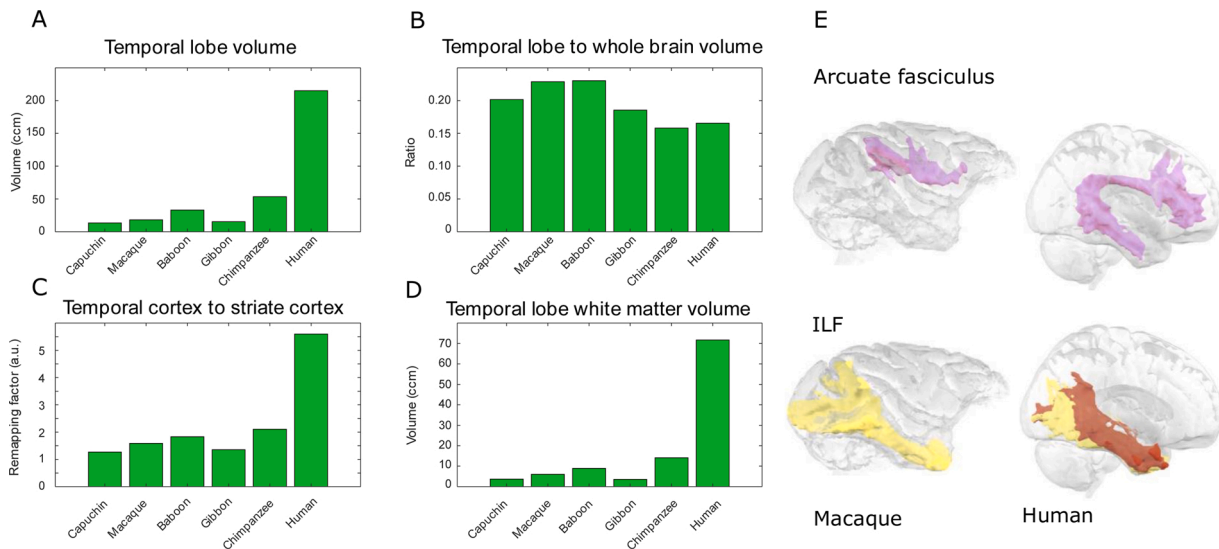

Fig. 3. Variation in temporal lobe size and connectivity across species. (A) Temporal lobe volume across species. (B) Ratio of temporal lobe to whole brain volume across species. (C) Remapping factors of temporal lobe compared to striate cortex across species. (D) White matter volume across species. (E) Arcuate fascicle and inferior longitudinal fascicle trajectories in macaques and humans. Data from A–D based on Rilling and Seligman (2002) and Brodmann (1913). Subfigure E is reproduced from Roumazeilles et al. (2020), published in PLoS Biology 18:e3000810. Brains not to scale.

connections of the temporal cortex run through a fiber bundle termed the inferior longitudinal fascicle (ILF). The existence of the ILF was originally controversial (Tusa and Ungerleider (1985), see Bajada et al. (2015) for an overview), but it is now recognized as a longitudinal bundle running mostly along the inferior temporal cortex, interconnecting it with occipital and parietal cortex (Schmahmann and Pandya, 2006). The middle longitudinal fascicle (MdLF; (Seltzer and Pandya, 1984)) connects the superior temporal cortex with parts of the inferior parietal cortex (Schmahmann and Pandya, 2006). A third longitudinal tract, the inferior fronto-occipital fascicle (IFOF) is more controversial. Tracer data in macaques originally identified a tract connecting caudal ventrolateral frontal cortex, via the extreme capsule, with the middle and rostral parts of the superior temporal sulcus (Petrides and Pandya, 1988). Diffusion MRI tractography, however, identified a more extensive pathway resembling the human IFOF according to some authors (Mars et al., 2016), but not others (Schmahmann et al., 2007; Takemura et al., 2017). More recent dissection studies suggest a longer pathway between frontal and occipital cortex running along the length of the temporal cortex in macaques (Decramer et al., 2018). Apart from the IFOF route, information from the temporal cortex can reach the medial and orbital frontal cortex through the bidirectional pathways of the uncinate fascicle (Petrides and Pandya, 1988; Folloni et al., 2019), which conveys information from the ventral visual stream to frontal cortex (Ungerleider et al., 1989). In conclusion, the macaque temporal lobe, especially the neocortical part, consists of uni- and multi-modal association cortex dealing with visual and auditory information at varying levels of abstraction. Its organizational scheme can be well characterized and provides a good basis for exploring modifications to this scheme in other species.

3. Variation in temporal lobe structure across species

3.1. Morphology and size

In the absence of comprehensive cytoarchitectonic studies, traditional comparative studies often focus on comparison of the morphology, i.e., the sulcal and gyral architecture, of a part of the brain as a first measure of comparison. Morphology of the temporal lobe differs remarkably across primates (Fig. 2). The prosimian bushbaby has an almost lissencephalic temporal lobe. Most monkey species have a

prominent longitudinal sulcus on the lateral surface of the temporal lobe, generally termed the superior temporal sulcus (STS) (Connolly, 1950). In some species, the STS is accompanied by an additional sulcus located more ventrally, termed the middle temporal sulcus by Connolly (1950), which can range from small dimples to a fully formed sulcus. Furthermore, ventral and posterior to the STS an occipito-temporal sulcus may be present. In the chimpanzee, the longitudinal sulcus ventral to the STS is fully formed and suggested to be homologous to the human inferior temporal sulcus, creating a prominent middle temporal gyrus. While the sulcal pattern is similar in the human, such a ventral temporal sulcus is less prominent in the other great apes. On the ventral aspect of the temporal lobe, a fusiform gyrus is evident in humans and other great apes, with its sulcal morphology showing similarities between chimpanzees and humans (Miller et al., 2020).

Comparisons of temporal lobe size across primates are rare. One of the most extensive comparisons was performed by Rilling and Seligman (2002) using structural MRI scans of 11 different primate species. When comparing total temporal lobe volume, they observed that human temporal lobe is up to five times larger than that of other primates, including the chimpanzee great ape (Fig. 3A). However, comparisons of absolute volume are often problematic in comparative science, as they neglect general scaling relationships. Thus, Rilling and Seligman also compared temporal lobe volume against the total brain volume. This investigation showed that the temporal lobes of monkeys and apes scale along different trajectories, with monkeys showing a greater temporal-lobe-to-whole-brain volume ratio than apes (Fig. 3B). Predictions of the human ratio based on a hypothetical human-sized ape brain are at the upper limit of the confidence intervals. As such, human temporal lobe is suggested to be slightly bigger than predicted for an ape with a brain the size of ours.

Comparing the size of the temporal cortex size against that of the remaining neocortex, however, can lead to biased conclusions. Parietal and frontal cortices are also large association areas that have likewise expanded in various lineages, including that leading to the human (Chaplin et al., 2013; Mars et al., 2017). The relevant question is not whether temporal cortex increased in comparison to these parts of the brain, but whether it has more tissue to devote to processing its incoming information. This argument was used in the context of prefrontal cortex by Passingham and Smaers (2014). They calculated what they called a ‘remapping factor’, the ratio of the size of the higher area

and the size of its primary input area. For the temporal cortex, the striate cortex, which receives visual information from the lateral geniculate nucleus, is an appropriate choice for the input area of the largely visual temporal cortex. Moreover, striate cortex scales with body size and size of the lateral geniculate nucleus (Bush and Allman, 2004; Passingham, 1973) and thus presents an unbiased reference. We tested the temporal cortex remapping factor using the data on the size of the cortical surface area of the temporal cortex provided by Rilling and Seligman (2002), supplemented with data from Brodmann (1913). This analysis shows that the human temporal remapping factor is three times larger than that of the chimpanzee. When removing the superior temporal gyrus from the equation, since it is likely to contain mostly auditory rather than visual areas, the human remapping factor is still clearly an outlier. Thus, the human temporal cortex has more neurons to devote to processing of incoming information compared to other primate species (Fig. 3C).

Another way to test for local changes in neocortex size is to directly register different species' brains to one another, using putative homologous landmarks as reference points. This approach was taken by Van Essen and Dierker (2007), who used a surface-based registration of the cortex to warp a macaque brain to human space. We generally assume that the formation of new sulci leads to an increase in surface, due to additional folding of otherwise comparable aspects of brain regions (such as e.g., volume). They showed that, in temporal cortex, a disproportionate increase in middle temporal- and temporoparietal areas is required for the macaque to match the human. Using the same surface-based registration technique, Chaplin and colleagues (2013) showed that posterior superior temporal cortex is a hotspot of expansion compared to other parts of neocortex across New World and Old World monkeys. A volume-based registration between the chimpanzee great ape and the human also suggested local expansions in human temporal cortex, in particular in posterior temporal cortex (Avants et al., 2006). Increased availability of data on fossil species and their integration with neuroimaging methods might soon allow such inferences to be expanded to human fossil species, with a recent study suggesting temporal lobe expansion in the human lineage (Pearson et al., 2020).

Expansions in temporal lobe volume are likely to be accompanied by cortical reorganization, with the expanded region changing the location of other areas (Mars et al., 2018b). This indeed has been the case in the temporal cortex. Motion sensitive area MT, for instance, is located in the posterior part of the superior temporal sulcus in the macaque, but located much more ventrally in the temporal cortex in the human brain (Huk et al., 2002). Interestingly, expansion of parts of the cortex is also reflected in greater individual variability across individuals within a species (Croxxon et al., 2018).

3.2. Connectivity

Together with the large volume of the human temporal lobe, Rilling and Seligman (2002) showed that humans have a disproportional volume of temporal lobe white matter (Fig. 3D). They argued the white matter volume was not only larger than predicted for overall brain size, but also larger than predicted for temporal lobe volume. Such results are interesting, as they suggest something fundamental has changed in the connections of the temporal lobe grey matter. A grey matter region's function is for a large part constrained by the input a region gets and the influence it can exert on the rest of the brain, in other words by its connectivity (Mars et al., 2018c; Passingham et al., 2002). Comparing the architecture of temporal lobe white matter across species might therefore be a fruitful avenue to understand species differences in function.

With this aim in mind, Mars and colleagues described each part of the cortical grey matter in both macaques and humans in terms of its connectivity to the major white matter fiber pathways (Mars et al., 2018b). They reported that the human brain contains a number of areas that have a profile of connections that cannot be found anywhere in the macaque brain. As expected, some of these were located in the lateral

frontal cortex, but the majority of species differences were found in the posterior part of the temporal cortex. The most outstanding, i.e. most 'uniquely human' part, was in the middle temporal gyrus. Comparing the connectivity of this part of the human temporal cortex to that of its best match across the macaque brain showed that the human temporal cortex had a much greater connectivity with the arcuate fascicle. This result is in line with the pioneering finding of Rilling and colleagues (2008), who showed in one of the first comparative diffusion MRI studies that the arcuate fascicle reaches a much greater temporal cortical territory in the human than in the macaque (Fig. 3E) or even in the chimpanzee.

The arcuate expansion in the human lineage has taken on an almost iconic status in the comparative MRI literature (Catani and Bambini, 2014; Mars et al., 2018a). However, it is important to highlight that other differences in white matter architecture across the primate order are apparent. For instance, when working on the comparison of macaque-human connectivity (Mars et al., 2018b), the authors showed that the precise definition of the ILF in the human brain has a strong effect on the resulting similarity of the inferior temporal cortex between species. This suggests that the increased morphological complexity of the human inferior temporal and fusiform cortex is accompanied by a more complex white matter organization. Such a suggestion is also consistent with observations from dissection studies showing that human ILF consists of multiple subbranches (Latini et al., 2017). This possibility was investigated by Roumazeilles and colleagues (2020), who reported that the ILF of humans, indeed of great apes in general, can be reliably subdivided into a lateral and a medial branch, whereas the macaque ILF consists of a single branch. Importantly, by systematically comparing connectivity profiles across the temporal cortex, they were able to show that the medial branch of human ILF is homologous to macaque ILF, whereas the lateral branch of ILF is a great ape specialization (Fig. 3E).

An independent comparison of temporal cortex connectivity with primary sensory areas identified another specialization in the great ape lineage. Bryant and colleagues investigated the likelihood of connections of primary visual area V1 and of the auditory core to reach the temporal cortex across macaques, chimpanzees, and humans (Bryant et al., 2019). In the chimpanzee and the human, but not in the macaque, connections originating in primary visual cortex were much more likely to reach the anterior temporal cortex. Similarly, connections originating in the auditory core were much more likely to reach association areas in the superior temporal gyrus in the chimpanzee and human. Finally, in the human, there are areas where the connectivity of visual and auditory areas overlapped, suggesting a human evolutionary specialization for novel multimodal association cortex in the anterior temporal lobe (ATL). This suggestion is in line with earlier evidence from the human literature, showing convergence of connectivity in human ATL (Binney et al., 2012; Bajada et al., 2019).

Taken together, these results suggest that changes in size and morphology of the temporal cortex are accompanied by changes in white matter. However, it is important to distinguish between different scenarios of evolutionary changes (Mars et al., 2018a). Since part of the temporal cortex has expanded in the human lineage, it is likely that white matter connections to such a region expanded accordingly, leading to an existing connectivity profile occupying a greater part of the temporal cortex. This is different from a scenario where a white matter pathway invades new cortical territory, leading to new connectivity profiles in temporal cortex. Eichert and colleagues devised approaches to distinguish between such scenarios. Focusing on the arcuate fascicle, they showed that cortical expansion of grey or white matter alone cannot account for the extensive temporal projections of this pathway (Eichert et al., 2019). They then went on to quantify the extent to which a white matter pathway's projection extends beyond what would be predicted by cortical expansion or relocation of areas between species. Apart from the arcuate fascicle, the ILF and the third branch of the superior longitudinal fascicle also showed evidence of extension into new

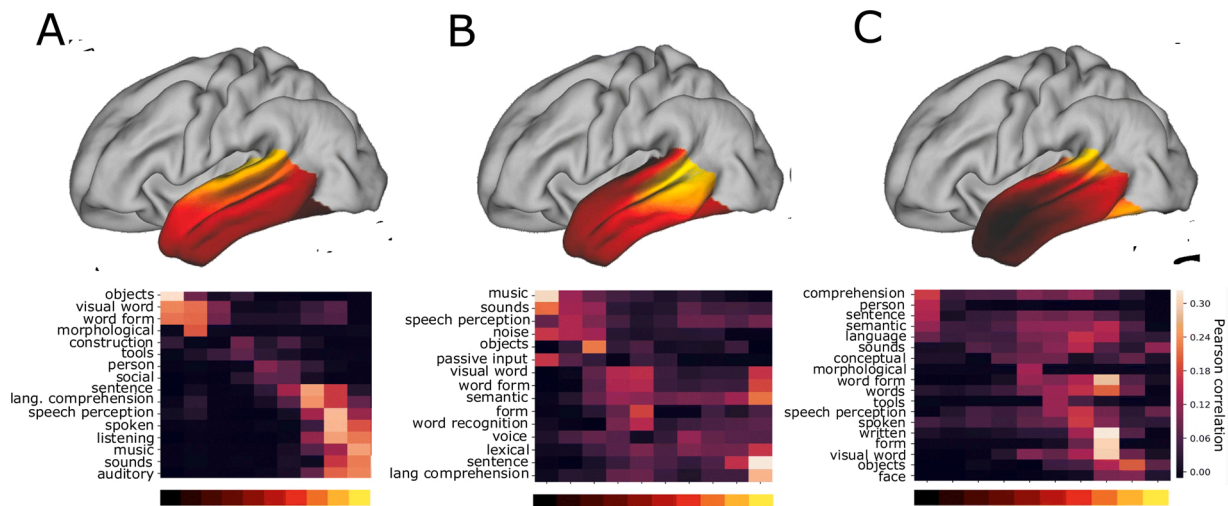

Fig. 4. Human connectivity gradients and functional decoding. *Top row:* Three dominant modes of connectivity change in the human brain. *Bottom Row:* Functional decoding of gradient percentiles. Figures reproduced from Blasquez Freches et al. (2020), published in Brain Structure and Function 225:1245-1260 under the Creative Commons Attribution 4.0 International License (<http://creativecommons.org/licenses/by/4.0/>).

cortical territory, albeit to a lesser extent (Eichert et al., 2020).

3.3. Principles of human temporal cortex organization

The work presented above showed that the morphology and size of temporal cortex vary across species and the remapping factors suggest that the temporal cortex can devote more neurons to the processing of information from the striate cortex in the human than in non-human primate species. The human temporal cortex also contains unique connectivity profiles, suggesting that white matter is involved in computations affording uniquely human aspects of cognition across different high-level domains.

One question arising from these expansions and reorganizations in human grey and white matter is how they fit into the simplified scheme of temporal lobe organization we presented above for the macaque. To test this explicitly, Blasquez Freches and colleagues (2020) explored a data-driven approach which identified principles of temporal cortex organization in the human based on connectivity data. They showed three overlapping principles of connectivity change (Fig. 4). The first and third principle appear similar to the ventral-dorsal and posterior-anterior principles we proposed above. The dorsal-ventral principle is mostly driven by the change in projections from inferior (ILF, UF) to superior (MdLF, acoustic radiation) tracts, while the posterior-anterior axis was dominated by the uncinate connections to the anterior temporal pole. The second principle of organization in the human brain shows a peak in the posterior dorsal temporal cortex, driven largely by the invasion of the arcuate fascicle into the posterior temporal cortex—a phenomenon that is unique to the human brain, as discussed above.

The use of data-driven techniques to elucidate principles of organization of a part of the cortex has been used to study the temporal cortex by a number of authors. Although differences in the employed techniques and in the areas of study, often including the allocortex of the medial temporal lobe, mean the results of the studies are not identical, some common themes appear (Bajada et al., 2017, 2019; Vos de Wael et al., 2021). Most studies agree on a dorsal-ventral organizational principle. An anterior-posterior dimension with the ATL forming a convergence zone is a theme that stands out (Bajada et al., 2019) and consistent with our anterior-posterior principle of organization. Furthermore, although not always described as a separate principle of organization, the effect of the expansion of the arcuate fascicle on temporal cortex organization is also evident in all studies (cf. Vos de Wael et al. (2021); Bajada et al. (2017)).

4. Variation in temporal lobe function across species

Although the particular ecological circumstances in which apes and humans evolved are a matter of debate, it seems likely that temporal areas adapted to a more general function compared to the feature conjunction coding for goal-directed behavior outlined above for the macaque. In particular, through the ability to categorize stimuli that this feature conjunction system allows, a semantic memory emerged that allow greater conceptual generalization across stimuli and modalities (Murray et al., 2017). In the human lineage in particular, reliance on conspecifics became important to meet the challenges of the environment (Tomasello, 2014). Many of the existing functions of temporal cortex, both in processing social and non-social information, could be coopted to deal with the challenge of navigating an increasingly complex social environment.

Variations in temporal lobe function across species are difficult to assess, given that functional studies are mainly limited to macaque and marmoset monkeys and the human. By necessity, much of our discussion will therefore focus on a comparison of functional studies in the human with the results outlined above in the macaque. We will take the three principles of human temporal lobe organization outlined above (Blasquez Freches et al., 2020) as a reference and discuss similarities and differences in their proposed functional roles. We then separately discuss uniquely human aspects of social cognition and their implementations in the brain, as they constitute a multitude of subprocesses that do not fit within a single category (Schurz et al., 2020) and eventually draw upon faculties involved along all three principles of organization.

4.1. Three principles of human temporal lobe organization

The first, dorsal-ventral organizational principle appears comparable between the macaque and the human. The ventral part consists of the ventral visual pathway mediated for a large part by the ILF. However, within this principle, there is substantial expansion of the lateral temporal cortex that, as discussed above, is associated with the appearance of the medial temporal gyrus and expansion of the ILF. Blasquez Freches and colleagues (2020) used functional decoding of their principles of organization (Fig. 4, bottom row) to investigate what functional roles are associated with them. They showed that intermediate values along the first principle (Fig. 4A), partially located in the middle temporal gyrus, correspond to functional activations related to high-level behavior. Functional studies showing activation in this part of the brain are

associated with key words such as ‘theory of mind’, ‘comprehension’, and ‘social cognitive’. Interestingly, these are more higher-level processes than found when decoding the more extreme ends, which yielded terms like ‘objects’, ‘faces’, ‘word form’ ventrally and ‘sounds’, ‘tone’, ‘voice’ dorsally.

Several authors have suggested the existence of a third pathway, in between the traditional ventral visual pathway along the temporal lobe and the dorsal visual pathway in the parietal lobe, which explains the occurrence of highest-level cognition at intermediate values of the gradient. For instance, based on functional data, [Weiner and Grill-Spector \(2013\)](#) argued for a third pathway from lateral occipital cortex towards the middle temporal gyrus that contributes to dynamic coding of stimuli and integration of visual information with other modalities. The dissociation between static and dynamic coding of stimuli is reminiscent of the dissociation already observed in macaque face processing ([Kravitz et al., 2013](#)). Interestingly, a new or elaborated pathway for integration of visual and other modality information dovetails with the increasing integration of visual and auditory information observed by [Bryant and colleagues \(2019\)](#) discussed above. Using a data-driven analysis of resting state fMRI data, [Haak and Beckmann \(2018\)](#) also argued for a third visual pathway in lateral occipital cortex, which might be consistent with the posterior section of the pathway identified by [Weiner and Grill-Spector](#).

The second principle we proposed in the macaque seems consistent with the third principle of organization observed in the human ([Figs. 1B and 4 C](#)). It concerns the increasing abstraction of processing when moving away from primary areas in the temporal cortex. Above, we argued that in the macaque this increasing coding of feature conjunctions forms the basis of the ability to categorize stimuli. Similar processes are evident in the human ventral visual pathway. Indeed, [Kriegeskorte and colleagues \(2008\)](#) used a representational similarity analysis to show that categorization clusters in inferior temporal cortex are similar between macaques and humans. The importance of human temporal cortex in categorization is also illustrated by the fact that it performs anticipatory coding of stimulus categories, even before visual stimuli are presented ([Uithol et al., 2021](#)). Illustrating that principle, [Jackson et al. \(2018\)](#) found a fronto-posterior organization of increasing domain-generalization in anterior parts of the human temporal lobe using Laplacian eigenmapping of task and resting-state fMRI data.

Elaborating on the macaque ability to form feature conjunctions and to perform categorizations to provide this information to prefrontal cortex, temporal cortex in great apes forms semantic representations. According to one prominent theory, the ‘hub and spoke’ theory of semantic cognition, ATL encodes knowledge of concepts through the learning of the higher-order relationships among various sensory, motor, linguistic and affective sources of information that are widely distributed in the cortex ([Rogers et al., 2004](#); [Lambon Ralph et al., 2010](#)). This model was formulated to account for a number of effects observed in patients with damage to this area, including the case of semantic dementia. Patients often show specific semantic impairments that result from an inability to combine different aspects of a stimuli. For instance, they overly rely on highly familiar concepts and they are unable to put together a picture and a word of the same object. In other words, they rely on modality-specific superficial similarities and less on semantic structure. It should be noted that ATL does not necessarily form a single region, and more recent formulations of the hub and spoke model emphasize a graded organization where connections from different parts of cortex converge in different parts of ATL rather than all in a single region ([Lambon Ralph et al., 2017](#)). Such a topographical organization can be an efficient way to combine information in a neural architecture ([Jbabdi et al., 2013](#)).

The final principle of organization found by [Blazquez Freches and colleagues \(2020\)](#) was centered around the arcuate fascicle’s projection into the posterior part of the temporal cortex ([Fig. 4B](#)), which seems to be a uniquely human phenomenon. Up until today we lack evidence for a third organizational principle in the macaque or other primates.

Functional decoding of the structural principles of organization suggests that there is a hotspot involved in ‘semantic processing’ in posterior temporal cortex; one that is distinct from the more anterior ATL semantic processing hub. It is informative to dissociate the semantic processing in the ATL and that in the posterior temporal cortex. [Noonan and colleagues \(2013\)](#) describe the ATL as important for the representation of conceptual knowledge, while posterior temporal cortex and parts of the angular gyrus are involved in semantic control, for instance the regulation of semantic activation in a task- and context-sensitive fashion. Notably, posterior temporal activation is prominent during production tasks, such as spoken language production—a traditional role of the arcuate fascicle. The dissociation is also illustrated by the disparate clinical effects of lesions to ATL and pMTG. ATL is associated with semantic dementia, the loss of core semantic concepts leading to multi-modal semantic impairments, while pMTG is associated with semantic aphasia, marked by general impairments in cognitive control accompanied by language related impairments ([Jefferies and Lambon Ralph, 2006](#); [Corbett et al., 2009](#)).

As an interesting point regarding semantics in posterior temporal cortex, it has been suggested that human temporal cortex stores semantic information about tools ([Frey, 2007](#)). In both the human and the macaque, inferior parietal cortex contains neurons that are involved in the planning of tool use. [Ramayya and colleagues \(2010\)](#) suggest that two pathways from MTG to inferior parietal cortex are involved in tool use in the human brain, one to supramarginal gyrus involved in integration of ventral stream object recognition and dorsal stream action planning pathways and one to supramarginal and angular gyrus predominantly involved in language. Although there are connections between IPL neurons and the ventral visual pathway in the macaque ([Zhong and Rockland, 2003](#)), parietal-temporal pathways are much more extensive in the human than in the macaque or chimpanzee ([Hecht et al., 2013](#)). Hecht and colleagues link this change to the way in which humans learn about tool use, with an emphasis on process learning in humans (i.e. to imitate an action) rather than product learning (copying the outcome of an action) in non-human primates.

As discussed above, this third principle of organization of the human temporal cortex is strongly driven by the extension of the arcuate fascicle. It is therefore sensible to interpret these functions in terms of the unique connections of this part of the brain. The extended connection between posterior temporal and ventral frontal cortex via what some authors describe as the long segment of the arcuate ([Catani and Bambini, 2014](#)) is traditionally associated with syntactic production and comprehension, but this view might be too narrow ([Hagoort, 2019](#)). A major challenge is to relate these novel arcuate connections to computational abilities that underlie human language behavior ([Roelofs, 2014](#); [Schomers et al., 2017](#)). Similarly, the increased connections between posterior temporal and inferior parietal cortex have yet to be explained in a computational framework, although some authors have suggested models in which human inferior parietal lobule can integrate information from temporal cortex to compute a contextual prior for action planning ([Verhagen et al., 2013](#)), which is an interesting conceptual extension of the contextual role of anterior temporal-frontal connectivity. In this context, it is notable that it is the temporal-parietal part of the arcuate fascicle that seems most developed in humans compared to chimpanzees ([Sierpowska et al., 2020](#)).

4.2. Social cognition and the temporal lobe

We already discussed the role of the temporal cortex in social processing in the macaque. Primates are highly social animals, and the complexity of their social life is reflected in the size of their neocortex ([Dunbar and Shultz, 2007](#)). It is well established that humans in particular show highly complex social behavior, being naturally cooperative and communicating through language ([Tomasello, 2009](#)). As such, our social behavior has been interpreted as the basis of our unique cognitive abilities ([Tomasello, 2014](#)). Indeed, several meta-analyses

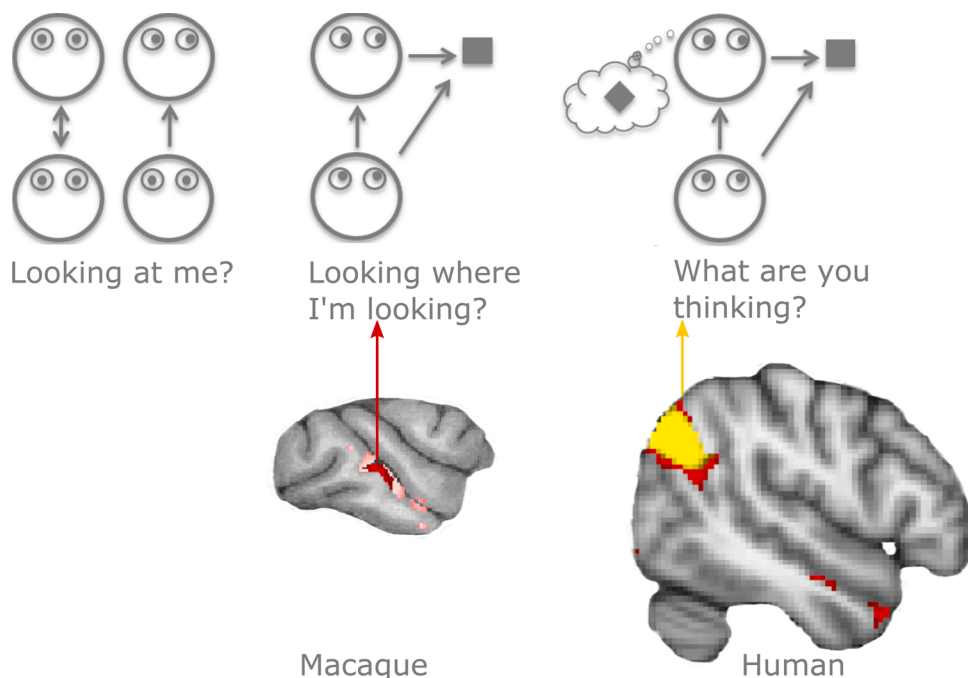

Fig. 5. Functional differences in processing of social information and their anatomical basis. Different types of information can be extracted from the direction of gaze of another person, ranging from simple detection of whether one is looked at in most species, to joint attention, to full attribution of belief states or mentalizing in humans. Joint attention relies on an area in macaque superior temporal sulcus that shows anatomical similarity to human TPJ, which is used in mentalizing. Top row based on Emery (2000); bottom row reproduced from Mars et al. (2013), published in Proceedings of the National Academy of Science USA 110:10806-10811. Brains not to scale.

showed that social information processing in the human activates similar areas to other behaviors, including language and semantic processing, and autobiographical memory (Andrews-Hanna et al., 2014; Schurz et al., 2020). The relationship between these processes is complex and the order of appearance of functions in the human lineage is difficult to reconstruct. Rather than providing an exhaustive discussion, we here highlight important social abilities and discuss them in the context of the processes outlined above: mentalizing, the processing of social stimuli, and social categorization.

Mentalizing or Theory of Mind, i.e., the capacity to attribute mental states to others even if they conflict with our knowledge of the world, is perhaps the most often discussed human social ability. Following Premack and Woodruff's article asking if the chimpanzee has a Theory of Mind (Premack and Woodruff, 1978), this question has been at the forefront of the study of uniquely human social cognition. Various models suggest humans have more sophisticated mentalizing abilities (Devaine et al., 2017) and individual differences in this ability correlate with grey matter volume in the temporal cortex (Lewis et al., 2011). In particular, the temporoparietal junction area (TPJ) at the posterior end of the temporal cortex is associated with this behavior (Saxe, 2006; Schurz et al., 2017). However, how this ability came about has remained an open question. Recently, a number of related models emphasize the cortical areas involved in processing dynamic aspects of faces and bodies as potential precursors for this ability.

As discussed above, processing of social stimuli in the macaque relies on a number of selective patches in the ventral visual stream. These patches are organized both posterior-anteriorly with increasing visual fields and robustness against perspective and dorsal-ventrally with more dorsally located regions coding for more dynamic aspects of social stimuli. Experiments from marmosets, macaques, chimpanzees, and humans suggest that at least these general principles are conserved across species (Tsao et al., 2008; Parr et al., 2009; Hung et al., 2015). Based on the consistent presence of both ventrally and dorsally located face patches, it has been argued that the more dorsally located regions coding for dynamic aspects of stimuli form a distinct, "social" visual pathway (Pitcher and Ungerleider, 2020), similar to the third visual pathway proposal discussed above. In general this flow of processing is in line with the increasing abstraction leading to the coding of feature conjunctions, we described earlier for non-social stimuli as our first

principle of organisation. In this view, the visual input to the STS is integrated with other sensory modalities to enable primates to understand and interpret the actions of others.

Elaboration of these aspects of information processing might form the computational basis of complex social processes like mentalizing, especially in light of the expansion and reorganization of posterior temporal cortex (Patel et al., 2019). Such a hypothesis was suggested by Mars and colleagues (2013) who observed that the human TPJ has a functional connectivity profile very similar to that of areas in the macaque middle superior temporal sulcus that contain neurons coding for the direction of attention of others (Perrett et al. (1992)). Following earlier models (Emery, 2000), it was suggested that extracting information relevant to the attention state of others is a precursor of human mentalizing abilities. Consistent with this suggestion, macaque STS and human TPJ both respond to unexpected social events (Behrens et al., 2008; Roumazeilles et al., 2021) and the locus of this activation in the macaque is consistent with a region shown to code for the focus of another's attention (Ramezanzpour and Thier, 2020). More recent computational evidence suggests that TPJ can code information in terms of the deviation from the perspective of the self (Kolling et al., in press), which could be interpreted as an elaboration of the macaque's ability to see whether another is attending different information than the self (Fig. 5).

The second aspect of social cognition we highlight is the role of anterior temporal lobe (ATL) in categorization in the social domain. Categorization in the social domains activates more dorsal parts of ATL compared to the non-social domain (Murray et al., 2017). Consistent with a role of ATL in processing social information, patients with semantic dementia often show social cognitive deficits (Irish et al., 2014). Zahn and colleagues (2007) showed activation of superior ATL when participants judged the meaning of social concepts over concepts related to animal behavior. Moreover, the ATL activation was not modulated by emotional valence, which did modulate activation in frontal cortex. This is reminiscent of the dissociation between ATL and frontal cortex in coding of value of emotionally valent entities, such as situations, encounters, or emotions. As such, ATL function is a likely candidate for an area where already existent functions provided a good exaptation for human social information processing.

A number of recent functional neuroimaging studies illustrate how this function of ATL contributes to human social information processing.

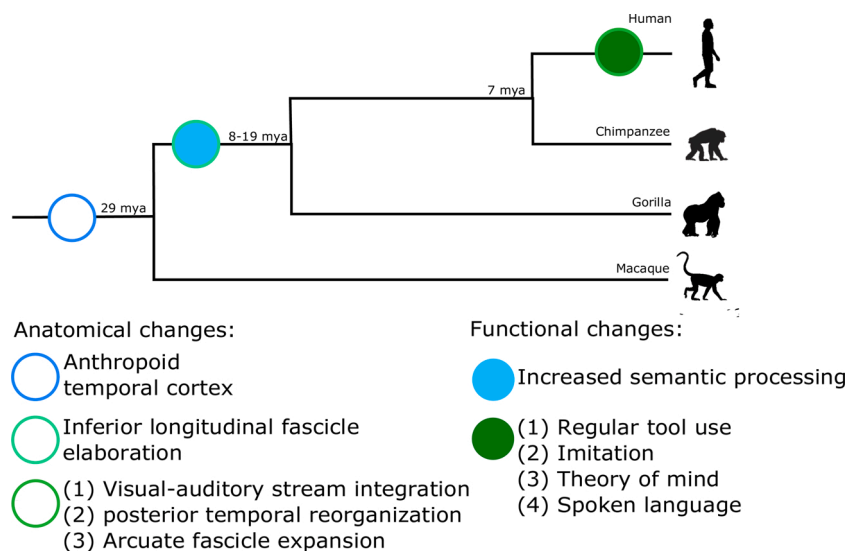

Fig. 6. Evolutionary overview of changes in temporal lobe structure and function in anthropoid primates. Hollow circles indicate anatomical changes in the temporal lobe; filled circles indicate changes in temporal lobe function.

Vijayakumar and colleagues (2020) highlighted the fact that humans engage in large social groups and that therefore it is a necessary skill to categorize people and to learn about their attributes first through the heuristic of the group level. Extending the hub and spoke idea of ATL, they showed that ATL coactivation with other parts of the brain representing social information increases over the course of learning the preferences of social groups (Vijayakumar et al., 2020). Along a different vein, Tsukiura and colleagues (2008) demonstrated that ATL shows increased activation with the recognition of famous or familiar faces. Successful recognition of a famous or familiar face relies on placing perceived stimuli in different contexts. These contexts or situations depend heavily on our social interactions with the perceived stimulus (such as interacting with a family member or talking about a celebrity). Again, this dovetails with the ATL's role in providing information for goal-directed behavior to frontal cortex. Summarizing the overall role of ATL in social information processing, Frith and Frith (2003) suggested it provides 'scripts' for social situations, emphasizing the integrative and context-dependent nature of the information processing in this part of the temporal lobe.

5. Conclusion

We started this review with the question of how human temporal cortex can be involved in many behaviors considered distinctly human. We have seen that temporal cortex has undergone significant changes across the primate lineages and in the lineage leading up to humans in particular. Human temporal cortex has expanded in size with respect to its input regions; it shows local expansions leading to the appearance of an additional gyrus in the ape lineage and relocation of areas particularly in the human; it has more white matter than expected for its size, which is reflected in the increased complexity of the ILF and invasion of the arcuate fascicle. Functionally, the human temporal cortex operates along the main principles that are apparent in the other well-studied temporal cortex, namely that of the macaque (see Fig. 6 for a schematic representation). Many of the 'human' functions of temporal cortex can therefore be seen as elaborations of functions present in other species. However, the expansion of the posterior temporal connections with inferior parietal and frontal cortex seem to enable changes that are closest to representing a 'step change', such as the cultural explosion about 60,000 years ago as we mention in the introduction.

We have echoed the sentiment expressed by recent work interpreting some of the specializations of the anthropoid brain in terms of a foraging

perspective (Mars and Bryant, 2021; Murray et al., 2017; Passingham and Wise, 2012). The human foraging niche is, of course, distinctively different from that of other primates. It has been argued that the social or cultural behavior of humans presents a particular solution to its foraging challenges (Tomasello et al., 2012). Processing of social information seems to cover many diverse activation patterns observed in human neuroimaging studies. However, as we have attempted to show, many of these social abilities are also in line with computations that are performed in a non-social context (Kolling et al. (in press); Behrens et al. (2008)), including improved categorization behavior in anthropoids and semantic processing in great apes.

Human temporal cortex is involved in generating some of the behaviors that are most fascinating in a comparative context, but the lack of detailed anatomical and functional data from a wide range of species is still apparent. We have provided a brief view on the state of the literature and highlighted some recent large-scale comparative work. Indeed, the increasing availability of anatomical neuroimaging data from many different species holds a great potential to understand how the structural basis of distinct abilities has come about (Friedrich et al., 2021). We hope that these new data will be successfully integrated with studies on the behavioural abilities of various temporal cortices and therefore will provide a new impetus into temporal cortex research.

Declaration of Competing Interest

The authors declare no competing interests.

Acknowledgements

M.B. is supported by an Open Competition grant from the Netherlands Organization for Scientific Research NWO to R.B.M. [ALWOP.366]; G.B.F. is supported through the Gravitation Grant 024.001.006 of the Language in Interaction Consortium from Netherlands Organisation for Scientific Research NWO; LR is supported by funding from the Biotechnology and Biological Sciences Research Council (BBSRC) UK [BB/M011224/1]; N.E. was a Wellcome Trust Doctoral student in Neuroscience at the University of Oxford [203730/Z/16/Z]; M.S. is supported by a Marie Skłodowska-Curie Individual Fellowship (MSCA-IF 844734); S.U. was supported by the Netherlands Organization for Scientific Research [452-13-015] to R.B.M.; the work of K.B. is supported by Biotechnology and Biological Sciences Research Council UK [BB/N019814/1]; the work of R.B.M. is supported by the

Biotechnology and Biological Sciences Research Council (BBSRC) UK [BB/N019814/1] and the Netherlands Organization for Scientific Research [452-13-015]. The Wellcome Centre for Integrative Neuroimaging is supported by core funding from the Wellcome Trust [203129/Z/16/Z].

References

- Allman, J., 1982. Reconstructing the evolution of the brain in primates through the use of comparative neurophysiological and neuroanatomical data. In: Armstrong, E., Falk, D. (Eds.), *Primate Brain Evolution. Methods and Concepts*. Plenum Press, New York.
- Andrews-Hanna, J.R., Smallwood, J., Spreng, R.N., 2014. The default network and self-generated thought: component processes, dynamic control, and clinical relevance. *Ann. N. Y. Acad. Sci.* 1316, 29–52.
- Avants, B.B., Schoenemann, P.T., Gee, J.C., 2006. Lagrangian frame diffeomorphic image registration: morphometric comparison of human and chimpanzee cortex. *Med. Image Anal.* 10, 397–412.
- Bajada, C.J., Lambon Ralph, M.A., Cloutman, L.L., 2015. Transport for language south of the Sylvian fissure: the routes and history of the main tracts and stations in the ventral language network. *Cortex* 69, 141–151.
- Bajada, C.J., Jackson, R.L., Haroon, H.A., Azadbakht, H., Parker, G.J.M., Lambon Ralph, M.A., Cloutman, L.L., 2017. A graded tractographic parcellation of the temporal lobe. *Neuroimage* 155, 503–512.
- Bajada, C.J., Trujillo-Barreto, N.J., Parker, G.J.M., Cloutman, L.L., Lambon Ralph, M.A., 2019. A Structural Connectivity Convergence Zone in the Ventral and Anterior Temporal Lobes: Data-driven Evidence From Structural Imaging. *Cortex*. Available at: <http://www.sciencedirect.com/science/article/pii/S0010945219302527> [Accessed July 16, 2019].
- Behrens, T.E.J., Hunt, L.T., Woolrich, M.W., Rushworth, M.F.S., 2008. Associative learning of social value. *Nature* 456, 245–249.
- Binder, J.R., Desai, R.H., 2011. The neurobiology of semantic memory. *Trends Cogn. Sci.* 15, 527–536.
- Binney, R.J., Parker, G.J.M., Lambon Ralph, M.A., 2012. Convergent connectivity and graded specialization in the rostral human temporal lobe as revealed by diffusion-weighted imaging probabilistic tractography. *J. Cogn. Neurosci.* 24, 1998–2014.
- Blazquez Freches, G., Haak, K.V., Bryant, K.L., Schurz, M., Beckmann, C.F., Mars, R.B., 2020. Principles of temporal association cortex organisation as revealed by connectivity gradients. *Brain Struct. Funct.* 225, 1245–1260.
- Brodmann, K., 1913. Neuere Forschungsergebnisse der Großhirnrinden-anatomie mit besonderer Berücksichtigung anthropologischer Fragen. *Arch. Gesellschaft Deutsch Naturforscher Ärzte* 85, 200–240.
- Bruner, E., 2018. Human paleoneurology and the evolution of the parietal cortex. *Brain Behav. Evol.* 91, 136–147.
- Bryant, K.L., Preuss, T.M., 2018. A comparative perspective on the human temporal lobe. In: Bruner, E., Oghara, N., Tanabe, H.C. (Eds.), *Digital Endocasts*. Springer Japan, Tokyo, pp. 239–258. Available at: http://link.springer.com/10.1007/978-4-431-56582-6_16 [Accessed June 7, 2018].
- Bryant, K.L., Glasser, M.F., Li, L., Jae-Cheol Bae, J., Jacquez, N.J., Alarcón, L., Fields, A., Preuss, T.M., 2019. Organization of extrastriate and temporal cortex in chimpanzees compared to humans and macaques. *Cortex* 118, 223–243.
- Bryant, K.L., Ardesch, D.J., Roumazeilles, L., Scholtens, L.H., Khrapitchev, A.A., Tendler, B.C., et al., 2021. Diffusion MRI data, sulcal anatomy, and tractography for eight species from the Primate Brain Bank. *Brain Struct. Funct.* In press.
- Bush, E.C., Allman, J.M., 2004. The scaling of frontal cortex in primates and carnivores. *Proc. Nat. Acad. Sci. USA* 101 (11), 3962–3966. <https://doi.org/10.1073/pnas.0305760101>.
- Catani, M., Bambini, V., 2014. A model for social communication and language evolution and development (SCALED). *Curr. Opin. Neurobiol.* 28, 165–171.
- Chaplin, T.A., Yu, H.-H., Soares, J.G.M., Gattass, R., Rosa, M.G.P., 2013. A conserved pattern of differential expansion of cortical areas in simian Primates. *J. Neurosci.* 33, 15120–15125.
- Conway, B.R., 2018. The organization and operation of inferior temporal cortex. *Annu. Rev. Vis. Sci.* 4, 381–402.
- Corbett, F., Jefferies, E., Ehsan, S., Lambon Ralph, M.A., 2009. Different impairments of semantic cognition in semantic dementia and semantic aphasia: evidence from the non-verbal domain. *Brain* 132, 2593–2608.
- Croxson, P.L., Forkel, S.J., Cerliani, L., Thiebaut de Schotten, M., 2018. Structural variability across the primate brain: a cross-species comparison. *Cereb. Cortex* 28, 3829–3841.
- Deacon, T., 1997. *The Symbolic Species*. W.W. Norton & Co, New York.
- Decramer, T., Swinnen, S., van Loon, J., Janssen, P., Theys, T., 2018. White matter tract anatomy in the rhesus monkey: a fiber dissection study. *Brain Struct. Funct.* 223, 3681–3688.
- Devaine, M., San-Galli, A., Trapanese, C., Bardino, G., Hano, C., Saint Jalme, M., Bouret, S., Masi, S., Daunizeau, J., 2017. Reading wild minds: a computational assay of Theory of Mind sophistication across seven primate species. *PLoS Comput. Biol.* 13, e1005833.
- Dobson, S.D., 2009. Socioecological correlates of facial mobility in nonhuman anthropoids. *Am. J. Phys. Anthropol.* 139, 413–420.
- Dunbar, R.I.M., Shultz, S., 2007. Evolution in the social brain. *Science* 317, 1344–1347.
- Eichert, N., Robinson, E.C., Bryant, K.L., Jbabdi, S., Jenkinson, M., Longchuan, L., Krug, K., Watkins, K., Mars, R.B., 2020. Cross-species cortical alignment identifies different types of anatomical reorganization in the primate temporal lobe. *eLife* 9. <https://doi.org/10.7554/eLife.53232>.
- Eichert, N., Verhagen, L., Folloni, D., Jbabdi, S., Khrapitchev, A.A., Sibson, N.R., Mantini, D., Sallet, J., Mars, R.B., 2019. What is special about the human arcuate fasciculus? Lateralization, projections, and expansion. *Cortex* 118, 107–115. <https://doi.org/10.1016/j.cortex.2018.05.005>.
- Emery, N.J., 2000. The eyes have it: the neuroethology, function and evolution of social gaze. *Neurosci. Biobehav. Rev.* 24, 581–604.
- Folloni, D., Sallet, J., Khrapitchev, A.A., Sibson, N., Verhagen, L., Mars, R.B., 2019. Dichotomous organization of amygdala/temporal-prefrontal bundles in both humans and monkeys Heilbronner S, Gold JI, Thiebaut de Schotten M, eds. *eLife* 8, e47175.
- Freedman, D.J., Riesenhuber, M., Poggio, T., Miller, E.K., 2003. A comparison of primate prefrontal and inferior temporal cortices during visual categorization. *J. Neurosci.* 23, 5235–5246.
- Frey, S.H., 2007. What puts the how in where? Tool use and the divided visual streams hypothesis. *Cortex* 43, 368–375.
- Friedrich, P., Forkel, S.J., Amiez, C., Balsters, J.H., Coulon, O., Fan, L., Goulas, A., Hadj-Bouziane, F., Hecht, E.E., Heuer, K., Jiang, T., Latzman, R.D., Liu, X., Loh, K.K., Patil, K.R., Lopez-Persem, A., Procyk, E., Sallet, J., Toro, R., Vickery, S., Weis, S., Wilson, C.R.E., Xu, T., Zerbi, V., Eickhoff, S.B., Margulies, D.S., Mars, R.B., Thiebaut de Schotten, M., 2021. Imaging evolution of the primate brain: The next frontier? *NeuroImage* 228, 117685.
- Friederici, A.D., 2011. The brain basis of language processing: from structure to function. *Physiol. Rev.* 91, 1357–1392.
- Frith, U., Frith, C.D., 2003. Development and neurophysiology of mentalizing. *Philos. Trans. R. Soc. Lond. B Biol. Sci.* 358, 459–473.
- Fukushima, M., Saunders, R.C., Leopold, D.A., Mishkin, M., Averbeck, B.B., 2014. Differential coding of conspecific vocalizations in the ventral auditory cortical stream. *J. Neurosci.* 34, 4665–4676.
- Garcin, B., Urbanski, M., Thiebaut de Schotten, M., Levy, R., Volle, E., 2018. Anterior temporal lobe morphometry predicts categorization ability. *Front. Hum. Neurosci.* 12. Available at: <https://www.frontiersin.org/articles/10.3389/fnhum.2018.00036/full> [Accessed January 5, 2021].
- Haak, K.V., Beckmann, C.F., 2018. Objective analysis of the topological organization of the human cortical visual connectome suggests three visual pathways. *Cortex* 98, 73–83.
- Hagoort, P., 2019. The neurobiology of language beyond single-word processing. *Science* 366, 55–58.
- Hecht, E.E., Gutman, D.A., Preuss, T.M., Sanchez, M.M., Parr, L.A., Rilling, J.K., 2013. Process versus product in social learning: comparative diffusion tensor imaging of neural systems for action execution—observation matching in macaques, chimpanzees, and humans. *Cereb. Cortex* 23, 1014–1024.
- Herculano-Houzel, S., 2012. The remarkable, yet not extraordinary, human brain as a scaled-up primate brain and its associated cost. *PNAS* 109, 10661–10668.
- Huk, A.C., Dougherty, R.F., Heeger, D.J., 2002. Retinotopy and functional subdivision of human areas MT and MST. *J. Neurosci.* 22, 7195–7205.
- Hung, C.-C., Yen, C.C., Ciuchta, J.L., Papoti, D., Bock, N.A., Leopold, D.A., Silva, A.C., 2015. Functional mapping of face-selective regions in the extrastriate visual cortex of the marmoset. *J. Neurosci.* 35, 1160–1172.
- Irish, M., Hodges, J.R., Piguet, O., 2014. Right anterior temporal lobe dysfunction underlies theory of mind impairments in semantic dementia. *Brain* 137, 1241–1253.
- Jackson, R.L., Bajada, C.J., Rice, G.E., Cloutman, L.R., Lambon Ralph, M.A., 2018. An emergent functional parcellation of the temporal cortex. *NeuroImage* 170, 385–399.
- Jbabdi, S., Sotiropoulos, S.N., Behrens, T.E., 2013. The topographic connectome. *Curr. Opin. Neurobiol.* 23, 207–215.
- Jefferies, E., Lambon Ralph, M.A., 2006. Semantic impairment in stroke aphasia versus semantic dementia: a case-series comparison. *Brain* 129, 2132–2147.
- Kaas, J.H., Hackett, T.A., 1999. “What” and “where” processing in auditory cortex. *Nat. Neurosci.* 2, 1045–1047.
- Kaas, J.H., Hackett, T.A., 2000. Subdivisions of auditory cortex and processing streams in primates. *PNAS* 97, 11793–11799.
- Kiani, R., Esteky, H., Mirpour, K., Tanaka, K., 2007. Object category structure in response patterns of neuronal population in monkey inferior temporal cortex. *J. Neurophysiol.* 97, 4296–4309.
- Klein, R.G., 2009. *The Human Career: Human Biological and Cultural Origins*, 3rd edition. University of Chicago Press, Chicago.
- Kobatake, E., Wang, G., Tanaka, K., 1998. Effects of shape-discrimination training on the selectivity of inferotemporal cells in adult monkeys. *J. Neurophysiol.* 80, 324–330.
- Kolling, N., Braunsdorf, M., Vijayakumar, S., Bekkering, H., Toni, I., Mars, R.B., (in press) Constructing others’ beliefs from one’s own using medial frontal cortex. *J. Neurosci.* <https://doi.org/10.1523/jneurosci.0011-21.2021>.
- Kravitz, D.J., Saleem, K.S., Baker, C.I., Ungerleider, L.G., Mishkin, M., 2013. The ventral visual pathway: an expanded neural framework for the processing of object quality. *Trends Cogn. Sci. (Regul. Ed.)* 17, 26–49.
- Kriegeskorte, N., Mur, M., Ruff, D.A., Kiani, R., Bodurka, J., Esteky, H., Tanaka, K., Bandettini, P.A., 2008. Matching categorical object representations in inferior temporal cortex of man and monkey. *Neuron* 60, 1126–1141.
- Ku, S.-P., Tolia, A.S., Logothetis, N.K., Goense, J., 2011. fMRI of the face-processing network in the ventral temporal lobe of awake and anesthetized macaques. *Neuron* 70, 352–362.
- Kumar, S., Stecher, G., Suleski, M., Hedges, S.B., 2017. TimeTree: a resource for timelines, timetrees, and divergence times. *Mol. Biol. Evol.* 34, 1812–1819.
- Lambon Ralph, M.A., Sage, K., Jones, R.W., Mayberry, E.J., 2010. Coherent concepts are computed in the anterior temporal lobes. *PNAS* 107, 2717–2722.
- Lambon Ralph, M.A., Jefferies, E., Patterson, K., Rogers, T.T., 2017. The neural and computational bases of semantic cognition. *Nat. Rev. Neurosci.* 18, 42–55.

- Latini, F., Martensson, J., Larsson, E.M., Fredrikson, M., Ahs, F., Hjortberg, M., Aldskogius, H., Ryttefors, M., 2017. Segmentation of the inferior longitudinal fasciculus in the human brain: a white matter dissection and diffusion tensor tractography study. *Brain Res.* 1675, 102–115.
- Leopold, D.A., Mitchell, J.F., Freiwald, W.A., 2017. Evolved mechanisms of High-level visual perception in primates. *Evolution of Nervous Systems*, 2nd ed., pp. 203–235.
- Lewis, P.A., Rezaie, R., Brown, R., Roberts, N., Dunbar, R.I.M., 2011. Ventromedial prefrontal volume predicts understanding of others and social network size. *NeuroImage* 57, 1624–1629.
- Mars, R., Bryant, K.L., 2021. Neuroecology: the brain in its world. in press. In: Della Sala, S. (Ed.), *Encyclopedia of Behavioral Neuroscience*, 2nd edition. Elsevier, Amsterdam.
- Mars, R.B., Passingham, R.E., Neubert, F.X., Verhagen, L., Sallet, J., 2017. Evolutionary specializations of human association cortex. In: Kaas, J.H. (Ed.), *Evolution of Nervous Systems*, 2nd, 4. Elsevier, Oxford, pp. 185–205.
- Mars, R.B., Sallet, J., Neubert, F.-X., Rushworth, M.F.S., 2013. Connectivity profiles reveal the relationship between brain areas for social cognition in human and monkey temporoparietal cortex. *Proc. Natl. Acad. Sci. U. S. A.* 110, 10806–10811.
- Mars, R., Foxley, S., Verhagen, L., Jbabdi, S., Sallet, J., Noonan, M.P., Neubert, F.-X., Andersson, J.L., Croxson, P.L., Dunbar, R.I.M., Khrapitchev, A.A., Sibson, N.R., Miller, K.L., Rushworth, M.F.S., 2016. The extreme capsule fiber complex in humans and macaque monkeys: a comparative diffusion MRI tractography study. *Brain Struct. Funct.* 221, 4059–4071.
- Mars, R.B., Eichert, N., Jbabdi, S., Verhagen, L., Rushworth, M.F.S., 2018a. Connectivity and the search for specializations in the language-capable brain. *Curr. Opin. Behav. Sci.* 21, 19–26.
- Mars, R.B., Sotiropoulos, S.N., Passingham, R.E., Sallet, J., Verhagen, L., Khrapitchev, A.A., Sibson, N., Jbabdi, S., 2018b. Whole brain comparative anatomy using connectivity blueprints. *eLife* 7, e35237.
- Mars, R.B., Passingham, R.E., Jbabdi, S., 2018c. Connectivity fingerprints: From areal descriptions to abstract spaces. *Trends Cognit. Sci.* 22, 1026–1037. <https://doi.org/10.1016/j.tics.2018.08.009>.
- Mishkin, M., Ungerleider, L.G., Macko, K.A., 1983. Object vision and spatial vision: two cortical pathways. *Trends Neurosci.* 6, 414–417.
- Murray, E.A., Wise, S.P., Graham, 2017. *The Evolution of Memory Systems. Ancestors, Anatomy, and Adaptations*. Oxford University Press, Oxford.
- Noonan, K.A., Jefferies, E., Visser, M., Lambon Ralph, M.A., 2013. Going beyond inferior prefrontal involvement in semantic control: evidence for the additional contribution of dorsal angular gyrus and posterior middle temporal cortex. *J. Cogn. Neurosci.* 25, 1824–1850.
- Parr, L.A., Hecht, E., Barks, S.K., Preuss, T.M., Votaw, J.R., 2009. Face processing in the chimpanzee brain. *Curr. Biol.* 19, 50–53.
- Passingham, R.E., 1973. Anatomical differences between the neocortex of man and other primates. *Brain, Behav. Evol.* 7 (5), 337–359. <https://doi.org/10.1159/000124422>.
- Passingham, R.E., Smaers, J.B., 2014. Is the Prefrontal Cortex Especially Enlarged in the Human Brain? Allometric Relations and Remapping Factors. *Brain, Behav. Evol.* 84, 156–166. <https://doi.org/10.1159/000365183>.
- Passingham, R.E., Stephan, K.E., Koetter, R., 2002. The anatomical basis of functional localization in the cortex. *Nat. Rev. Neurosci.* 3 (8), 606–616.
- Passingham, R.E., Wise, S.P., 2012. *The Neurobiology of the Prefrontal Cortex. Anatomy, Evolution, and the Origin of Insight*. Oxford University Press, Oxford.
- Patel, G.H., Sestieri, C., Corbetta, M., 2019. The Evolution of the Temporoparietal Junction and Posterior Superior Temporal Sulcus. *Cortex*. Available at: <http://www.sciencedirect.com/science/article/pii/S0010945219300462> [Accessed February 19, 2019].
- Pearson, A., Polly, P.D., Bruner, E., 2020. Is the middle cranial fossa a reliable predictor of temporal lobe volume in extant and fossil anthropoids? *Am. J. Phys. Anthropol.* 172, 698–713.
- Perrett, D.I., Hietanen, J.K., Oram, Benson, P.J., 1992. Organization and functions of cells responsive to faces in the temporal cortex. *Philos. Trans. Biol. Sci.* 335, 23–30.
- Petkov, C.I., Logothetis, N.K., Obleser, J., 2009. Where are the human speech and voice regions, and do other animals have anything like them? *Neuroscientist* 15, 419–429.
- Petrides, M., Pandya, D.N., 1988. Association fiber pathways to the frontal cortex from the superior temporal region in the rhesus monkey. *J. Comp. Neurol.* 273, 52–66.
- Pitcher, D., Ungerleider, L.G., 2020. Evidence for a third visual pathway specialized for social perception. *Trends Cogn. Sci.* 0 Available at: [https://www.cell.com/trends/cognitive-sciences/abstract/S1364-6613\(20\)30278-3](https://www.cell.com/trends/cognitive-sciences/abstract/S1364-6613(20)30278-3) [Accessed January 8, 2021].
- Premack, D., Woodruff, G., 1978. Does the chimpanzee have a theory of mind? *Behav. Brain Sci.* 4, 515–526.
- Ramayya, A.G., Glasser, M.F., Rilling, J.K., 2010. A DTI investigation of neural substrates supporting tool use. *Cereb. Cortex* 20, 507–516.
- Ramezani, H., Thier, P., 2020. Decoding of the other's focus of attention by a temporal cortex module. *Proc. Natl. Acad. Sci. U. S. A.* 117, 2663–2670.
- Rauschecker, J.P., Scott, S.K., 2009. Maps and streams in the auditory cortex: nonhuman primates illuminate human speech processing. *Nat. Neurosci.* 12, 718–724.
- Rilling, J.K., Seligman, R.A., 2002. A quantitative morphometric comparative analysis of the primate temporal lobe. *J. Hum. Evol.* 42, 505–533.
- Rilling, J.K., Glasser, M.F., Preuss, T.M., Ma, X., Zhao, T., Hu, X., Behrens, T.E.J., 2008. The evolution of the arcuate fasciculus revealed with comparative DTI. *Nat. Neurosci.* 11, 426–428.
- Roelofs, A., 2014. A dorsal-pathway account of aphasic language production: the WEAVER++/ARC model. *Cortex* 59, 33–48.
- Rogers, T., Lambon Ralph, M.A., Garrard, P., Bozeat, S., McClelland, J., Hodges, J.R., Patterson, K., 2004. Primate Brain Evolution: comparative studies of brains of living mammal species reveal major trends in the evolutionary development of primate brains, and analysis of endocasts from fossil primate braincases suggests when these specializations occurred. *Psychol. Rev.* 111, 205–235.
- Roumazeilles, L., Eichert, N., Bryant, K.L., Folloni, D., Sallet, J., Vijayakumar, S., Foxley, S., Tendler, B.C., Jbabdi, S., Revely, C., Verhagen, L., Dershowitz, L.B., Guthrie, M., Flach, E., Miller, K.L., Mars, R.B., 2020. Longitudinal connections and the organization of the temporal cortex in macaques, great apes, and humans. *PLoS Biol.* 18, e3000810.
- Roumazeilles, L., Schurz, M., Lojkiewicz, M., Verhagen, L., Schueffgen, U., Marche, K., Mahmoodi, A., Emberton, A., Simpson, K., Joly, O., Khamassi, M., Rushworth, M.F.S., Mars, R.B., Sallet, J., 2021. Social prediction modulates activity of macaque superior temporal cortex. *Sci. Adv.* 7 eabh2392.
- Saxe, R., 2006. Uniquely human social cognition. *Curr. Opin. Neurobiol.* 16, 235–239.
- Schmahmann, J.D., Pandya, D.N., 2006. *Fiber Pathways of the Brain*. Oxford University Press, Oxford.
- Schmahmann, J.D., Pandya, D.N., Wang, R., Dai, G., D'Arceuil, H.E., de Crespigny, A.J., Wedeen, V.J., 2007. Association fibre pathways of the brain: parallel observations from diffusion spectrum imaging and autoradiography. *Brain* 130, 630–653.
- Schomers, M.R., Garagnani, M., Pulvermüller, F., 2017. Neurocomputational consequences of evolutionary connectivity changes in perisylvian language cortex. *J. Neurosci.* 37, 3045–3055.
- Schurz, M., Tholen, M.G., Perner, J., Mars, R.B., Sallet, J., 2017. Specifying the brain anatomy underlying temporo-parietal junction activations for theory of mind: a review using probabilistic atlases from different imaging modalities. *Hum. Brain Mapp.* 38, 4788–4805.
- Schurz, M., Radua, J., Tholen, M.G., Maliske, L., Margulies, D.S., Mars, R.B., Sallet, J., Kanske, P., 2020. Toward a hierarchical model of social cognition: a neuroimaging meta-analysis and integrative review of empathy and theory of mind. *Psychol. Bull.*
- Seltzer, B., Pandya, D.N., 1984. Further observations on parieto-temporal connections in the rhesus monkey. *Exp. Brain Res.* 55, 301–312.
- Sierpowska, J., Bryant, K.L., Janssen, N., Blazquez Freches, G., Römkens, M., Mangnus, M., Kessels, R.P.C., Roelofs, A., Mars, R.B., Piai, V., 2020. Left Temporal Lobe Language Hubs—A Comparative Approach.
- Spitsyna, G., Warren, J.E., Scott, S.K., Turkheimer, F.E., Wise, R.J.S., 2006. Converging language streams in the human temporal lobe. *J. Neurosci.* 26, 7328–7336.
- Srihasam, K., Mandeville, J.B., Morocz, I.A., Sullivan, K.J., Livingstone, M.S., 2012. Behavioral and anatomical consequences of early versus late symbol training in macaques. *Neuron* 73, 608–619.
- Takemura, H., Pestilli, F., Weiner, K.S., Keliris, G.A., Landi, S.M., Sliwa, J., Ye, F.Q., Barnett, M.A., Leopold, D.A., Freiwald, W.A., Logothetis, N.K., Wandell, B.A., 2017. Occipital white matter tracts in human and macaque. *Cereb. Cortex* 27, 3346–3359.
- Tomasello, M., 2009. *Why We Cooperate*. MIT Press, Cambridge.
- Tomasello, M., Melis, A.P., Tennie, C., Wyman, E., Herrmann, E., 2012. Two key steps in the evolution of human cooperation. *Curr. Anthropol.* 53, 673–692.
- Tomasello, M., 2014. *A Natural History of Human Thinking*. Harvard University Press, Cambridge.
- Tsao, D.Y., Freiwald, W.A., Knutsen, T.A., Mandeville, J.B., Tootell, R.B.H., 2003. Faces and objects in macaque cerebral cortex. *Nat. Neurosci.* 6, 989–995.
- Tsao, D.Y., Moeller, S., Freiwald, W.A., 2008. Comparing face patch systems in macaques and humans. *PNAS* 105, 19514–19519.
- Tsukiura, T., Suzuki, C., Shigemune, Y., Mochizuki-Kawai, H., 2008. Differential contributions of the anterior temporal and medial temporal lobe to the retrieval of memory for person identity information. *Hum. Brain Mapp.* 29, 1343–1354.
- Tusa, R.J., Ungerleider, L.G., 1985. The inferior longitudinal fasciculus: a reexamination in humans and monkeys. *Ann. Neurol.* 18, 583–591.
- Uthol, S., Bryant, K.L., Toni, I., Mars, R.B., 2021. The anticipatory and task driven nature of visual perception. *Cereb. Cortex*.
- Ungerleider, L.G., Gaffan, D., Pelak, V.S., 1989. Projections from inferior temporal cortex to prefrontal cortex via the uncinate fascicle in rhesus monkeys. *Exp. Brain Res.* 76, 473–484.
- Van Essen, D.C., Dierker, D.L., 2007. Surface-based and probabilistic atlases of primate cerebral cortex. *Neuron* 56, 209–225.
- Verhagen, L., Dijkerman, H.C., Medendorp, W.P., Toni, I., 2013. Hierarchical organization of parietofrontal circuits during goal-directed action. *J. Neurosci.* 33, 6492–6503.
- Vijayakumar, S., Hartstra, E., Mars, R.B., Bekkering, H., 2020. Neural mechanisms of predicting individual preferences based on group membership. *Soc. Cogn. Affect. Neurosci.*
- Vos de Wael, R., Royer, J., Tavakoli, S., Wang, Y., Paquola, C., Benkarim, O., Eichert, N., Larivière, S., Xu, T., Misis, B., Smallwood, J., Valk, S.L., Bernhardt, B.C., 2021. Structural connectivity gradients of the temporal lobe serve as multiscale axes of brain organization and cortical evolution. *Cereb. Cortex*. <https://doi.org/10.1093/cercor/bhab149>. Available at: [Accessed June 21, 2021].
- Weiner, K.S., Grill-Spector, K., 2013. Neural representations of faces and limbs neighbor in human high-level visual cortex: evidence for a new organization principle. *Psychol. Res.* 77, 74–97.
- Yovel, Galit, Freiwald, Winrich A., 2013. Face recognition systems in monkey and human: are they the same thing? *F1000PrimeReports* 5 (10). <https://doi.org/10.12703/P5-10>.
- Zahn, R., Moll, J., Krueger, F., Huey, E.D., Garrido, G., Grafman, J., 2007. Social concepts are represented in the superior anterior temporal cortex. *Proc. Natl. Acad. Sci. U. S. A.* 104, 6430–6435.
- Zhong, Y.-M., Rockland, K.S., 2003. Inferior parietal lobule projections to anterior inferotemporal cortex (Area TE) in macaque monkey. *Cereb. Cortex* 13, 527–540.