



Universiteit  
Leiden  
The Netherlands

## Towards optical detection of a single electron

Moradi, A.

### Citation

Moradi, A. (2021, February 23). *Towards optical detection of a single electron. Casimir PhD Series*. Retrieved from <https://hdl.handle.net/1887/3149275>

Version: Publisher's Version

License: [Licence agreement concerning inclusion of doctoral thesis in the Institutional Repository of the University of Leiden](#)

Downloaded from: <https://hdl.handle.net/1887/3149275>

**Note:** To cite this publication please use the final published version (if applicable).

Cover Page



Universiteit Leiden



The handle <https://hdl.handle.net/1887/3149275> holds various files of this Leiden University dissertation.

**Author:** Moradi, A.

**Title:** Towards optical detection of a single electron

**Issue Date:** 2021-02-23

# 1

## Introduction

Competition for miniaturizing electronic circuits and pushing their extent to the size of atoms and molecules has intensified significantly. Concurrently, quantum integrated photonics circuits are considered as a reliable platform to build quantum computers. The key to nanoelectronics, quantum technology, and the fabrication of quantum integrated devices is a correct understanding of the rules governing the nanoworld. Gaining knowledge in the field of nanotechnology demands developing and advancing our observation tools. Different types of electron microscopes, atomic force microscopes (AFM), optical imaging systems, and many other techniques were developed to enable insights into nanoscience. In many of these techniques, the observation is limited to the surface of the sample, whereas its inner parts remain unexplored. Moreover, the act of measuring by itself may alter the measurement circumstances or even damage the sample. For instance, bombarding the sample with high-energy electrons during scanning electron microscopy can change the sample's structure dramatically (a well-known effect is carbonaceous film formation on the surface of the sample).<sup>1,2</sup> Another example is atomic force microscopy (AFM), where a direct contact of the tip may damage both sample and AFM's tip.<sup>3-5</sup> Among nanoscience methods, the optical methods are exceptional because of their ability to observe and probe a sample without disturbing it. However, the advantage of contactless monitoring by optical methods comes at the cost of a severe diffraction limit in spatial resolution, which appears as a major obstacle to their use at nanometer scales. The invention of single-molecule spectroscopy<sup>6</sup> and super-resolution microscopy<sup>7</sup> broke through this limit and made the optical detection of individual molecules possible.

The light emitted and absorbed by molecules contains information not only about the molecule itself but also about its local environment. Single-molecule spectroscopy (SMS) translates this information into a detectable signal. In a single-molecule experiment, the molecule acts as an extremely sensitive immediate probe of its local environment. The local information can be received and read out as changes in the spectral response of the probe molecule.<sup>8-12</sup> Many different molecular systems have been developed to screen changes in nano-environment, from temperature,<sup>13-17</sup> electric fields,<sup>17-25</sup> to mechanical stress<sup>26-28</sup> and pressure in a crystal.<sup>29</sup> In addition, a single fluorescent molecule is an excellent single-photon light source capable of producing millions of photons per second<sup>30-32</sup> that is comparable with other single-photon emitters such as impurity vacancy centers and quantum dots. All these applications depend on accurate knowledge of the optical properties of molecular systems that can be performed using spectroscopy.

## 1.1. Single-molecule fluorescence spectroscopy and microscopy

Abbe's optical diffraction limit states that the smallest resolvable distance between the features in an optical system is about half the illumination light wavelength. This limits the resolution of optical microscopes to about 200 nm for visible light. However, optical detection of single atoms in the gas phase exists for almost 50 years.<sup>33-35</sup> In many applications such as remote sensing in biology and solid-state physics or as coherent single-photon sources in quantum physics, the molecule needs to be immersed inside its natural medium, i.e., it is surrounded by many other molecules. Such an environment is completely different from the ultrahigh vacuum needed for single-atom detection. In 1990, Orrit and Bernard have shown that it is possible to resolve one molecule of pentacene embedded inside a crystal of p-terphenyl.<sup>6</sup> Considering the

size of a fluorescent molecule (of the order of 1 nm) and the crowded environments of the molecule, this detection is far beyond all mentioned limits and shows the fantastic capability of single-molecule spectroscopy (SMS). SMS is based on high-resolution fluorescence excitation spectroscopy driven by a tunable narrow-band laser. The emission and absorption energy of a molecule is randomly shifted by defects in its environment, and this energy is used to spatially address each molecule in a crystal lattice<sup>7,36–38</sup> and to spectrally resolve it in low-temperature measurements.<sup>8,9</sup>

The invention of SMS was an outstanding step toward visualizing the nanoscale phenomena. It brought the ability to study nature on its simplest level, avoiding the complexities of an ensemble measurement. As fluorescent molecules are small, they can be easily placed in the vicinity of the desired phenomenon in a crystal or attached to proteins inside a cell. They are flexible and can be designed and synthesized for a specific application. Thanks to the methods of synthetic chemistry, probe molecules in a molecular system are replicated with identical chemical structures, making single-molecule data as reproducible as theoretically possible. All these phenomenal features made molecules and SMS a popular tool in biology, chemistry, solid-state physics, and quantum physics. In our experiments, we took advantage of high-resolution single-molecule spectroscopy at liquid-helium temperatures to spectrally select fluorescent molecules and study their optical properties in different host molecular systems.

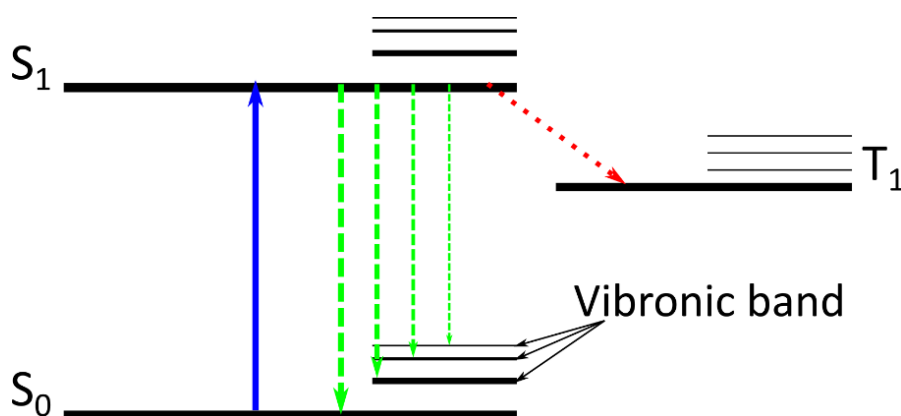

**Figure 1.1:** Energy diagram of a molecule presenting singlet ground  $S_0$  and first excited state  $S_1$  and the triplet state  $T_1$ , each with their vibrational or vibronic bands. The blue solid arrow shows absorption, the green dashed arrows show fluorescence emission, and the red dotted arrow shows intersystem crossing to the triplet state.

The basic principle of SMS can be described by the energy diagram of a single organic molecule showed in Figure 1.1. The diagram presents the molecule's ground electronic state  $S_0$ , excited state  $S_1$ , and the lowest triplet state  $T_1$ . For each energy level several vibrational levels are also shown. In a typical SMS measurement, the molecule is pumped by a laser from the lowest vibrational ground-state energy level to the lowest vibrational level of the first excited state, commonly denoted as (0-0) transition. This transition is purely electronic, i.e., it does not involve any creation or destruction of vibrational quanta and is therefore called the zero-phonon line (ZPL). The excited molecule relaxes back to its ground state by either releasing the energy as heat or emitting a photon (green dashed arrows in Figure 1.1). The emitted light is called fluorescence and has equal energy to, or lower energy than, the excitation light. Therefore, the red-shifted part of the fluorescence emission is easily distinguished from scattered light by means of a long-pass filter.

The ZPL linewidth is described by equation 1.1, where  $T_2$  is the total coherence lifetime that is a function of the excited state lifetime  $T_1$ , and pure decoherence lifetime  $T_2^*$ , determined by phonons and other bath fluctuations. At liquid helium temperature (below 5 K) phonon population is weak or negligible so the homogeneous Lorentzian width of ZPL can reach its lifetime limit of a few nanosecond. Compared with the optical frequency, the ZPL transition linewidth is about  $10^7$  times narrower. The tiny ZPL linewidth makes the line extremely sensitive to the smallest changes in the nano-environment of the molecule. Any variation of electric or strain field leads to a detectable shift in the ZPL energy. Therefore, with a careful selection of probe (guest) molecule and transparent matrix (host molecule), the ZPL can be precisely addressed and the desired perturbation (electric field in our case) can be read out.

$$\gamma_{\text{ZPL}} = \frac{1}{\pi T_2} = \frac{1}{2\pi T_1} + \frac{1}{\pi T_2^*} \quad (1.1)$$

In addition to the ground and excited singlet states, organic molecules generally exhibit a third state in between, known as the triplet state. Transitions between singlet and triplet states are known as intersystem crossing (ISC) transitions. ISC transitions are spin-forbidden and the transition rate for the systems studied in this thesis is very low. The branching ratio from the excited singlet to the triplet is typically below  $10^{-6}$ .<sup>39,40</sup> As the molecule stops interacting with the laser when it is in its triplet state, ISC transitions switch the fluorescence emission off and on. The triplet state is also known as the dark state. Although intersystem crossing has interesting applications such as making optical transistors, this topic is not directly relevant to the questions developed in this thesis.

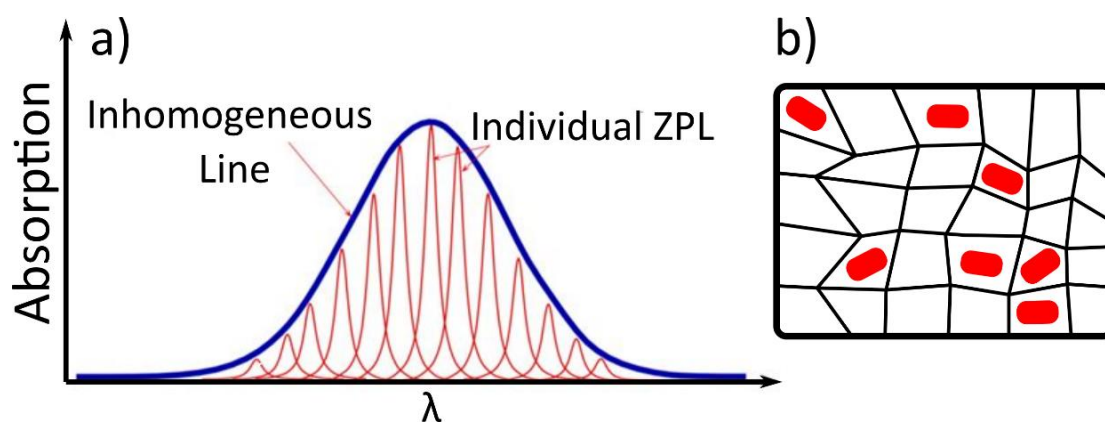

**Figure 1.2:** a) Gaussian lineshape of inhomogeneous broadening produced by superposition of individual ZPL of many inserted molecules in the crystal. b) Schematics of different insertion geometries in a host matrix.

In case of many embedded guest molecules in a host matrix, molecules insert in (slightly) different geometries (Figure 1.2b). Each of the insertion sites is affected by different random defects in the crystal and different local strain and electric fields. In consequence, the homogenous ZPL of each individual molecule is slightly shifted away from the average position. The superposition of all the energies forms a more-or-less Gaussian distribution, centered at the average resonance frequency. This Gaussian distribution is known as an inhomogeneous profile and its width as the inhomogeneous broadening. The inhomogeneous line is sketched in Figure 1.2 beside schematics of different insertion geometries in a crystal.

The other important parameter in SMS measurements is the concentration of guest molecules. The optimum contrast against background in a single-molecule measurement is reached when, in a small frequency interval, only one molecule in the focal volume of the exciting laser is excited resonantly. Other molecules in this focal volume will be too far detuned from the laser to significantly contribute to the fluorescence signal. In other words, the collected fluorescence light from the focal volume will be emitted by one molecule only. The inhomogeneous broadening causes molecules in the focal volume to have different ZPL energies. If the energy difference is more than the ZPL linewidth, the molecules are spectrally selectable. Assuming a focal volume of  $1 \mu\text{m}^3$ , the concentration needs to be a few micromolar at most to excite one molecule per excitation volume and per width of the frequency scan.

## 1.2. SMS experimental setup

Various set-ups have been developed for use in SMS. Exciting molecules by focusing light with a long-focal-length lens and collecting the fluorescence light with a parabolic mirror, focusing and collecting by a parabolic mirror, exciting the molecule through an optical fiber for a crystal attached to its tip and collecting with a parabolic mirror, and even exciting through a tiny pinhole ( $5 \mu\text{m}$ ) and collecting on the other side of the pinhole are some examples of SMS experimental set-ups. In all these methods the major focus has been on increasing the collecting efficiency.

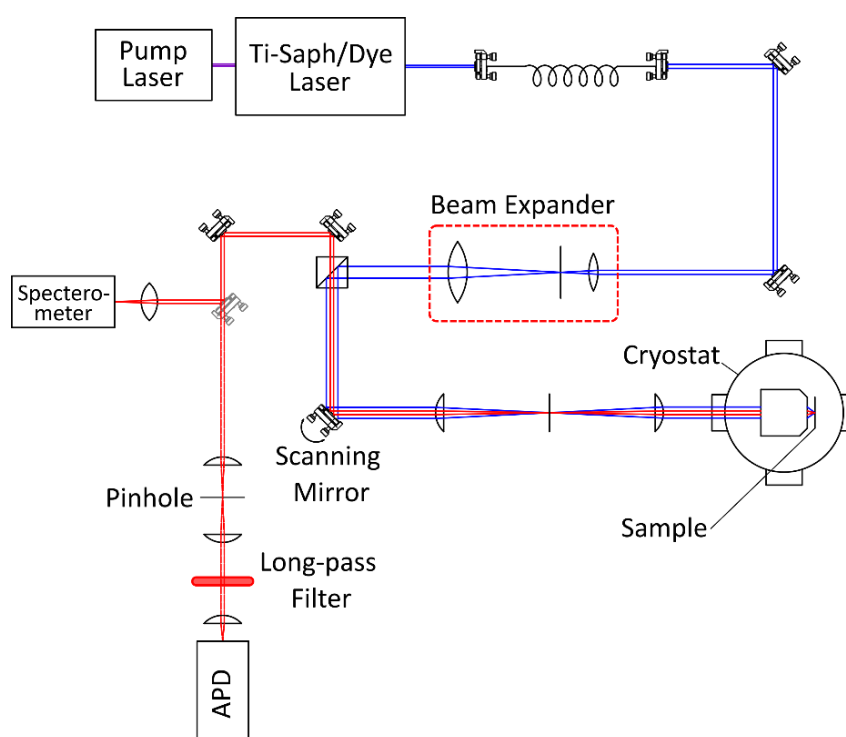

**Figure 1.3:** The schematics of the optical setup for single-molecule spectroscopy.

The development of single-photon detectors has brought the ability to use simpler microscopy methods such as confocal microscopy. In the studies presented in this thesis confocal microscopy (Figure 1.3) was used to detect single molecules and do spectroscopy on them. The excitation light produced by precisely tuneable lasers was sent to the set-up. The excitation light was focused on the sample by a low-temperature objective ( $\text{NA} = 0.7$ ). A galvanometric mirror placed in the focal point of an optical  $4f$  system moves the beam in order to scan the

sample and search for molecules. The fluorescence light was collected via the same objective. The collected light was filtered spatially by a pinhole and spectrally by a long-pass filter. The fluorescence light was sent to either an avalanche photodiode (APD) for absorption measurements or to a spectrometer for emission spectroscopy.

### 1.3. Molecule sensitivity to electric field

The spectral lines of atoms and molecules shift in the presence of an external electric field. This phenomenon is known as Stark effect, named after Johannes Stark, who discovered it in 1913. From the classical point of view, the Stark effect originates from the polarization of charge carriers in the molecules or atoms under the influence of an electric-field perturbation. The new charge distribution introduces changes of energy levels. Figure 1.3 shows schematics of energy levels in a two-level system such as a molecule. The energy levels are different before and after applying the electric field. The different changes in the energy of ground state  $S_0$  and excited state  $S_1$  lead to a shift in absorption energy.

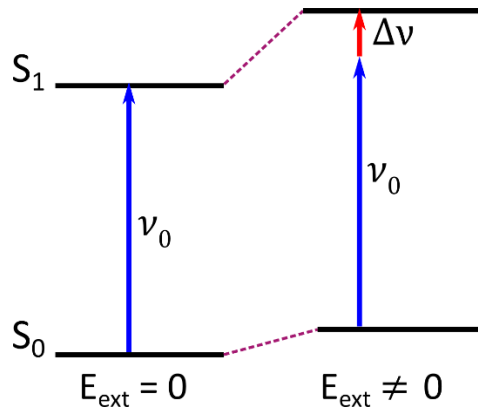

**Figure 1.4:** The schematics of energy level of a two-level system. Changes in the energy level after applying an external electric field lead to a shift in absorption energy  $\nu_1 = \nu_0 + \Delta\nu$ .

In the presence of an external electric field  $\vec{E}_{ext}$ , the energy of a level can be approximated by a Taylor series:

$$\begin{aligned} W(\vec{E}) &= W_1 + W_2 + \dots \\ &= -\vec{\mu}f_l\vec{E}_{ext} - \frac{1}{2}\alpha f_l^2 E_{ext}^2 + \dots, \end{aligned} \quad (1.2)$$

where  $\vec{\mu}$  is the dipole moment of the molecule,  $f_l$  is a local electric field correction factor, and  $\alpha$  is the molecule's polarizability. Using equation (1.2) the Stark shift of a molecule ZPL is given by the equation 1.3:

$$\begin{aligned} h\Delta\nu &= \Delta W_{S_1} - \Delta W_{S_0} \\ &= -\Delta\vec{\mu}f_l \cos\theta E_{ext} - \frac{1}{2}\Delta\alpha f_l^2 E_{ext}^2 + \dots, \end{aligned} \quad (1.3)$$

where  $\theta$  is the angle between the external electric field and the molecule dipole moment. The first part of the equation (1.3) defines the linear Stark shift, and the second element represents the quadratic Stark shift. The linear Stark effect is the result of existence of a dipole moment



in molecules with broken inversion symmetry while the quadratic Stark shift arises from the molecule's polarizability and occurs in centro-symmetric molecules.

The Stark effect is the source of a molecule's sensitivity to the electric field. Small perturbations of the electric field in the environment of a molecule are detectable by measuring the Stark shift of the molecule ZPL. Besides monitoring the electric field in the nano-environment, the Stark effect can be used to tune molecular absorption and emission.<sup>22</sup> Single-molecule spectroscopy provides the ability to measure shifts in the order of 1 MHz for the resonance frequency of a molecule.<sup>7,23</sup> Such a high resolution enables many applications such as learning information about the dipole moment and polarizability of a chromophore and optical tracking quasi-static charges or even single-charge detection.

## 1.4. Outline

In this research, we studied molecular systems with an emphasis on improving their sensitivity to electric fields. We also investigated the operation and realization of a photonic device using an organic single molecule as an interface between elementary charges in an electronic circuit and the laboratory. This device could be used as a quantum coherent information exchange platform between electrons and flying photons.

In Chapter 2, an ultra-sensitive molecular system based on the large aromatic polycyclic hydrocarbon DBT embedded in a 2,3-dibromo-naphthalene crystal was developed. We monitored its response to an external electric field and found it to surpass that of earlier-studied systems, while presenting reliable signals for every single guest DBT molecule in the crystal. In Chapter 3, we report our discovery of a new phenomenon: laser-induced charge generation in three different matrixes and its effect on the excitation spectra of DBT guest molecules. This effect was used to achieve long-lived shifts of the spectral lines of single DBT emitters and to tune them to a frequency of interest. In chapter 4 the working principle of single-electron transistors (SET) is described from a theoretical viewpoint. Then our approach towards optical detection of a single electron by using SETs to control single charge movement is presented. We report our progress in fabrication methods to make SET suitable for the optical study of charge movement and localization in Chapter 5. Finally, the efforts, challenges, and experimental data towards single-charge detection is described in chapter 6.

## References

- (1) Watson, J. H. L. An Effect of Electron Bombardment upon Carbon Black. *Journal of Applied Physics* 1947, 18 (2), 153–161. <https://doi.org/10.1063/1.1697597>.
- (2) Folch, A.; Servat, J.; Esteve, J.; Tejada, J.; Seco, M. High-vacuum versus “Environmental” Electron Beam Deposition. *Journal of Vacuum Science & Technology B: Microelectronics and Nanometer Structures Processing, Measurement, and Phenomena* 1996, 14 (4), 2609–2614. <https://doi.org/10.1116/1.588994>.
- (3) Strahlendorff, T.; Dai, G.; Bergmann, D.; Tutsch, R. Tip Wear and Tip Breakage in High-Speed Atomic Force Microscopes. *Ultramicroscopy* 2019, 201, 28–37. <https://doi.org/10.1016/j.ultramic.2019.03.013>.
- (4) Meli, F.; Küng, A. AFM Investigation on Surface Damage Caused by Mechanical Probing with Small Ruby Spheres. *Meas. Sci. Technol.* 2007, 18 (2), 496–502. <https://doi.org/10.1088/0957-0233/18/2/S24>.
- (5) Komai, K.; Minoshima, K.; Inoue, S. Fracture and Fatigue Behavior of Single Crystal Silicon Microelements and Nanoscopic AFM Damage Evaluation. *Microsystem Technologies* 1998, 5 (1), 30–37. <https://doi.org/10.1007/s005420050137>.
- (6) Ambrose, W. P.; Basché, Th.; Moerner, W. E. Detection and Spectroscopy of Single Pentacene Molecules in a P-terphenyl Crystal by Means of Fluorescence Excitation. *J. Chem. Phys.* 1991, 95 (10), 7150–7163. <https://doi.org/10.1063/1.461392>.
- (7) Hell, S. W.; Wichmann, J. Breaking the Diffraction Resolution Limit by Stimulated Emission: Stimulated-Emission-Depletion Fluorescence Microscopy. *Opt. Lett.*, OL 1994, 19 (11), 780–782. <https://doi.org/10.1364/OL.19.000780>.
- (8) Moerner, W. E. Physical Principles and Methods of Single-Molecule Spectroscopy in Solids. In *Single-Molecule Optical Detection, Imaging and Spectroscopy*; John Wiley & Sons, Ltd, 2007; pp 1–30. <https://doi.org/10.1002/9783527614714.ch1>.
- (9) Orrit, M.; Bernard, J. Single Molecule Spectroscopy. *Mod. Phys. Lett. B* 1991, 05 (11), 747–751. <https://doi.org/10.1142/S0217984991000927>.
- (10) Fleury, L.; Zumbusch, A.; Orrit, M.; Brown, R.; Bernard, J. Spectral Diffusion and Individual Two-Level Systems Probed by Fluorescence of Single Terrylene Molecules in a Polyethylene Matrix. *Journal of Luminescence* 1993, 56 (1), 15–28. [https://doi.org/10.1016/0022-2313\(93\)90049-S](https://doi.org/10.1016/0022-2313(93)90049-S).
- (11) Ambrose, W. P.; Moerner, W. E. Fluorescence Spectroscopy and Spectral Diffusion of Single Impurity Molecules in a Crystal. *Nature* 1991, 349 (6306), 225–227. <https://doi.org/10.1038/349225a0>.

- (12) Zumbusch, A.; Fleury, L.; Brown, R.; Bernard, J.; Orrit, M. Probing Individual Two-Level Systems in a Polymer by Correlation of Single Molecule Fluorescence. *Phys. Rev. Lett.* 1993, 70 (23), 3584–3587. <https://doi.org/10.1103/PhysRevLett.70.3584>.
- (13) Jang, S.; Cao, J.; Silbey, R. J. On the Temperature Dependence of Molecular Line Shapes Due to Linearly Coupled Phonon Bands. *J. Phys. Chem. B* 2002, 106 (33), 8313–8317. <https://doi.org/10.1021/jp0208440>.
- (14) Ashraf, I.; Konrad, A.; Lokstein, H.; Skandary, S.; Metzger, M.; Djouda, J. M.; Maurer, T.; Adam, P. M.; Meixner, A. J.; Brecht, M. Temperature Dependence of Metal-Enhanced Fluorescence of Photosystem I from *Thermosynechococcus Elongatus*. *Nanoscale* 2017, 9 (12), 4196–4204. <https://doi.org/10.1039/C6NR08762K>.
- (15) Verdal, N.; Kelley, A. M. Temperature Dependence of Phonon Sidebands in Line-Narrowed Fluorescence Spectra of Chromophores in Glasses. *J. Chem. Phys.* 2003, 118 (17), 7985–7992. <https://doi.org/10.1063/1.1565318>.
- (16) Ye, J.; Zhao, Y.; Ng, N.; Cao, J. Width of Phonon Sidebands in the Brownian Oscillator Model. *J. Phys. Chem. B* 2009, 113 (17), 5897–5904. <https://doi.org/10.1021/jp809425g>.
- (17) Nicolet, A. A. L.; Bordat, P.; Hofmann, C.; Kol'chenko, M. A.; Kozankiewicz, B.; Brown, R.; Orrit, M. Single Dibenzoterrylene Molecules in an Anthracene Crystal: Main Insertion Sites. *ChemPhysChem* 2007, 8 (13), 1929–1936. <https://doi.org/10.1002/cphc.200700340>.
- (18) Orrit, M.; Bernard, J.; Zumbusch, A.; Personov, R. I. Stark Effect on Single Molecules in a Polymer Matrix. *Chemical Physics Letters* 1992, 196 (6), 595–600. [https://doi.org/10.1016/0009-2614\(92\)86000-8](https://doi.org/10.1016/0009-2614(92)86000-8).
- (19) Tamarat, Ph.; Lounis, B.; Bernard, J.; Orrit, M.; Kummer, S.; Kettner, R.; Mais, S.; Basché, Th. Pump-Probe Experiments with a Single Molecule: Ac-Stark Effect and Nonlinear Optical Response. *Phys. Rev. Lett.* 1995, 75 (8), 1514–1517. <https://doi.org/10.1103/PhysRevLett.75.1514>.
- (20) Brunel, Ch.; Tamarat, Ph.; Lounis, B.; Woehl, J. C.; Orrit, M. Stark Effect on Single Molecules of Dibenzanthanthrene in a Naphthalene Crystal and in a N-Hexadecane Shpol'skii Matrix. *J. Phys. Chem. A* 1999, 103 (14), 2429–2434. <https://doi.org/10.1021/jp983956t>.
- (21) Bordat, P.; Orrit, M.; Brown, R.; Würger, A. The Anomalous Stark Effect of Single Terrylene Molecules in P-Terphenyl Crystals. *Chemical Physics* 2000, 258 (1), 63–72. [https://doi.org/10.1016/S0301-0104\(00\)00173-7](https://doi.org/10.1016/S0301-0104(00)00173-7).
- (22) Orrit, M.; Bernard, J.; Mouhsen, A.; Talon, H.; Möbius, D.; Personov, R. I. Stark Effect in Langmuir—Blodgett Films Studied by Hore-Burning. *Chemical Physics Letters* 1991, 179 (3), 232–236. [https://doi.org/10.1016/0009-2614\(91\)87029-B](https://doi.org/10.1016/0009-2614(91)87029-B).
- (23) Bernard, J.; Talon, H.; Orrit, M.; Möbius, D.; Personov, R. I. Stark Effect in Hole-Burning Spectra of Dye-Doped Langmuir-Blodgett Films. *Thin Solid Films* 1992, 217 (1), 178–186. [https://doi.org/10.1016/0040-6090\(92\)90627-N](https://doi.org/10.1016/0040-6090(92)90627-N).

- (24) Kulzer, F.; Matzke, R.; Bräuchle, C.; Basché, Th. Nonphotochemical Hole Burning Investigated at the Single-Molecule Level: Stark Effect Measurements on the Original and Photoproduct State. *J. Phys. Chem. A* 1999, 103 (14), 2408–2411. <https://doi.org/10.1021/jp9839448>.
- (25) Faez, S.; Verhart, N. R.; Markoulides, M.; Buda, F.; Gourdon, A.; Orrit, M. Design and Synthesis of Aromatic Molecules for Probing Electric Fields at the Nanoscale. *Faraday Discuss.* 2015, 184 (0), 251–262. <https://doi.org/10.1039/C5FD00065C>.
- (26) Davies, G. Approximate Widths of Zero Phonon Lines Broadened by Point Defect Strain Fields. *J. Phys. D: Appl. Phys.* 1971, 4 (9), 1340–1345. <https://doi.org/10.1088/0022-3727/4/9/314>.
- (27) Tian, Y.; Navarro, P.; Orrit, M. Single Molecule as a Local Acoustic Detector for Mechanical Oscillators. *Phys. Rev. Lett.* 2014, 113 (13), 135505. <https://doi.org/10.1103/PhysRevLett.113.135505>.
- (28) Kol'chenko, M. A.; Nicolet, A. A. L.; Galouzis, M. D.; Hofmann, C.; Kozankiewicz, B.; Orrit, M. Single Molecules Detect Ultra-Slow Oscillators in a Molecular Crystal Excited by Ac Voltages. *New J. Phys.* 2009, 11 (2), 023037. <https://doi.org/10.1088/1367-2630/11/2/023037>.
- (29) Müller, A.; Richter, W.; Kador, L. Pressure Effects on Single Molecules of Terrylene in P-Terphenyl. *Chemical Physics Letters* 1995, 241 (5), 547–554. [https://doi.org/10.1016/0009-2614\(95\)00670-Y](https://doi.org/10.1016/0009-2614(95)00670-Y).
- (30) Brunel, C.; Lounis, B.; Tamarat, P.; Orrit, M. Triggered Source of Single Photons Based on Controlled Single Molecule Fluorescence. *Phys. Rev. Lett.* 1999, 83 (14), 2722–2725. <https://doi.org/10.1103/PhysRevLett.83.2722>.
- (31) Lounis, B.; Moerner, W. E. Single Photons on Demand from a Single Molecule at Room Temperature. *Nature* 2000, 407 (6803), 491–493. <https://doi.org/10.1038/35035032>.
- (32) De Martini, F.; Di Giuseppe, G.; Marrocco, M. Single-Mode Generation of Quantum Photon States by Excited Single Molecules in a Microcavity Trap. *Phys. Rev. Lett.* 1996, 76 (6), 900–903. <https://doi.org/10.1103/PhysRevLett.76.900>.
- (33) Itano, W. M.; Bergquist, J. C.; Wineland, D. J. Laser Spectroscopy of Trapped Atomic Ions. *Science* 1987, 237 (4815), 612–617. <https://doi.org/10.1126/science.237.4815.612>.
- (34) Dehmelt, H. G. Radiofrequency Spectroscopy of Stored Ions I: Storage\*\*Part II: Spectroscopy Is Now Scheduled to Appear in Volume V of This Series. In *Advances in Atomic and Molecular Physics*; Bates, D. R., Estermann, I., Eds.; Academic Press, 1968; Vol. 3, pp 53–72. [https://doi.org/10.1016/S0065-2199\(08\)60170-0](https://doi.org/10.1016/S0065-2199(08)60170-0).
- (35) Diedrich, F.; Krause, J.; Rempe, G.; Scully, M. O.; Walther, H. Laser Experiments with Single Atoms as a Test of Basic Physics. *IEEE Journal of Quantum Electronics* 1988, 24 (7), 1314–1319. <https://doi.org/10.1109/3.968>.

(36) Klar, T. A.; Engel, E.; Hell, S. W. Breaking Abbe's Diffraction Resolution Limit in Fluorescence Microscopy with Stimulated Emission Depletion Beams of Various Shapes. *Phys. Rev. E* 2001, 64 (6), 066613.

<https://doi.org/10.1103/PhysRevE.64.066613>.

(37) Hess, S. T.; Girirajan, T. P. K.; Mason, M. D. Ultra-High Resolution Imaging by Fluorescence Photoactivation Localization Microscopy. *Biophysical Journal* 2006, 91 (11), 4258–4272. <https://doi.org/10.1529/biophysj.106.091116>.

(38) Rust, M. J.; Bates, M.; Zhuang, X. Sub-Diffraction-Limit Imaging by Stochastic Optical Reconstruction Microscopy (STORM). *Nature Methods* 2006, 3 (10), 793–796. <https://doi.org/10.1038/nmeth929>.

(39) Verhart, N. R.; Navarro, P.; Faez, S.; Orrit, M. Intersystem Crossing Rates of Single Perylene Molecules in Ortho-Dichlorobenzene. *Phys. Chem. Chem. Phys.* 2016, 18 (26), 17655–17659. <https://doi.org/10.1039/C6CP02678H>.

(40) Lawetz, V.; Orlandi, G.; Siebrand, W. Theory of Intersystem Crossing in Aromatic Hydrocarbons. *J. Chem. Phys.* 1972, 56 (8), 4058–4072. <https://doi.org/10.1063/1.1677816>.

