



Universiteit
Leiden
The Netherlands

Developmental regulation and evolution of cAMP signalling in Dictyostelium

Alvarez-Curto, E.

Citation

Alvarez-Curto, E. (2007, October 23). *Developmental regulation and evolution of cAMP signalling in Dictyostelium*. Retrieved from <https://hdl.handle.net/1887/12476>

Version: Not Applicable (or Unknown)

License:

Downloaded from: <https://hdl.handle.net/1887/12476>

Note: To cite this publication please use the final published version (if applicable).

Chapter Three

Characterization of an adenosine kinase in *Dictyostelium discoideum*

Abstract

cAMP plays a pivotal role in *Dictyostelium* development controlling morphogenesis, cell movement and cell differentiation. The degradation of extracellular cAMP by the action of the extracellular phosphodiesterases produces 5'AMP that is subsequently degraded to adenosine by the activity of the 5'nucleotidase enzyme. Adenosine is known to block several cAMP-induced responses by inhibiting the binding of cAMP to surface cAMP receptors. Adenosine is also proposed to suppress secondary tip formation and to regulate pattern formation in the slug stage. This work describes the identification and characterization of the *Dictyostelium* adenosine kinase gene, *DdADK*. *DdADK* phosphorylates adenosine to form 5'AMP and is present both inside and outside the cells. The deduced *DdADK* protein sequence shares homology with adenosine kinases of higher eukaryotes and with microbial ribokinases. *DdADK* is expressed during the entire course of development, but expression decreases about three-fold during tip and slug formation. Up to culmination *DdADK* is expressed in all cells, but in fruiting bodies expression is confined to the upper and lower cup regions. *DdADK* null mutants (*adk*) develop normally but show a two-fold increase in slug size, which agrees with a putative role of adenosine in tip suppression.

Abbreviations: *ADK*: adenosine kinase; *Ado*: adenosine; *5'AMP*: adenosine 5'-monophosphate; *cAMP*: adenosine 3',5'-monophosphate; *5'NT*: 5'nucleotidase; *ALP*: alkaline phosphatase; *AMD*: adenosine monophosphate deaminase; *AC*: adenylyl cyclase; *PDE*: phosphodiesterase; *SpcAMPs*: adenosine 3',5'-monophosphorothioate *Sp*-isomer.

Introduction

Dynamic cAMP signalling regulates key aspects of multicellular development in the social amoeba *Dictyostelium discoideum*. Upon starvation, some cells start to secrete pulses of the chemoattractant cAMP, which are relayed by neighbouring cells. This results in the propagation of cAMP waves through the cell population and aggregation of cells towards the source of the pulses. Mound-shaped aggregates are formed which give rise to one or several tips that elongate into finger-shaped slugs. Each tip is an autonomous oscillator that attracts and controls cells within the aggregate. The size of the resulting slug is determined by the potency of the tip to suppress competing oscillators, a property known as tip dominance (Dormann and Weijer, 2001; Schaap, 1986; Schaap and Wang, 1984). During slug formation cells differentiate into prespore and prestalk cells with prespore cells at the posterior and prestalk cells in the anterior part of the slug. This pattern is established as follows: in the slug posterior there is a constant inter-conversion of prespore cells into anterior-like cells that is proposed to be caused by the secretion of a prespore inhibitor, DIF, by the prespore cells (Kay and Thompson, 2001). The anterior-like cells move forwards by chemotaxis towards cAMP and establish the prestalk region. In addition, adenosine has been put forward as the inhibitor of prespore differentiation in the prestalk region (Schaap and Wang, 1986).

Adenosine acts as a cAMP antagonist. It inhibits cAMP-induced responses such as cAMP binding to the specific receptors, cARs, therefore blocking cAMP relay (Theibert and Devreotes, 1984), the formation of competing tips and prespore differentiation (Schaap and Wang, 1986; Weijer and Durston, 1985). *Dictyostelium* has two cell surface adenosine-binding sites, the β -receptor (K_d 350 μ M) and the α -receptor (K_d 0.8 μ M) (Newell, 1982; Van Haastert and Kien, 1983), as opposed to higher organisms that present up to four surface adenosine receptors (Fredholm et al., 2001) and intracellular adenosine binding sites (Londos and Wolff, 1977). The cell surface and intracellular adenosine binding sites show different affinities for adenosine analogues. The cell surface receptors do not tolerate modification of the ribose moiety, and are therefore called R-sites, while the intracellular binding sites does not tolerate modification of the purine moiety and are called P-sites. Recent studies have indicated that the P-site resides in the catalytic core of mammalian adenylyl cyclases (Fredholm et al., 2001; Johnson et al., 1989; Londos and Wolff, 1977). In *Dictyostelium*, the inhibition of cAMP binding

to cAR1 shows P-site specificity, as do the inhibition of all cAMP induced responses (Alvarez-Curto et al., 2006; Theibert and Devreotes, 1984; Van Lookeren Campagne et al., 1986).

In *Dictyostelium* adenosine is produced mainly by the action of the extracellular cAMP phosphodiesterase (*PdsA*) and 5'nucleotidase (*5'nt*) respectively (Fig. 1), but several other enzymes are involved in its metabolism. In this work I present the identification of an adenosine kinase gene (*DdADK*) that encodes the enzyme responsible for the conversion of adenosine into 5'AMP. I have investigated the biochemical activity of the ADK enzyme and consequences of loss of the *ADK* gene for *Dictyostelium* development.

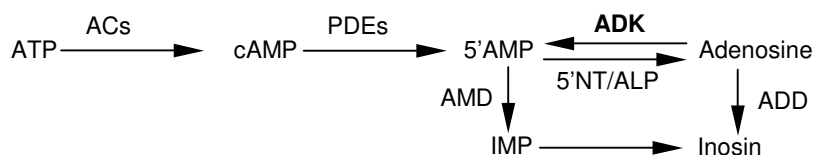

Figure 1. cAMP and adenosine metabolism in *Dictyostelium*

ADK: adenosine kinase; Ado: adenosine; 5'AMP: adenosine 5'-monophosphate; cAMP: adenosine 3', 5'-monophosphate; 5'NT: 5' nucleotidase; ALP: alkaline phosphatase; AMD: adenosine monophosphate deaminase; ADD: adenosine deaminase; ACs: adenyl cyclases; PDEs: phosphodiesterases.

Material and methods

Cell culture and development conditions

D.discoideum NC4 cells were grown in association with *Klebsiella aerogenes* on SM agar plates. AX2 cells were grown in HL5 axenic medium. After transformation the medium was supplemented with either 5 µg/ml blasticidin (ICN, USA) for knockout selection or with 20-200 µg/ml G418 (Sigma, USA) for cells transformed with the *PsA-LacZ* construct. To induce multicellular development cells were harvested from exponentially growing cultures, washed twice in PB (10 mM Na/K-phosphate buffer pH 6.5) and incubated at 22°C on PB agar (1.5% agar in 10 mM Na/K phosphate buffer pH 6.5), unless otherwise stated.

Identification and reconstruction of the gene

The *Dictyostelium* genome and the Japanese cDNA projects (<http://genome.imb-jena.de/Dictyostelium>; <http://dictycdb.biol.tsukuba.ac.jp/>) were screened for sequences sharing homology to the sequence of the rat adenosine kinase. A putative *Dictyostelium* ADK (*DdADK*) consensus sequence was assembled using 7 cDNA sequences obtained from the Japanese database in combination with other 5 genomic DNA hits. This yielded a 1280 nucleotides long sequence plus 1000 bp 3' UTR. The deduced coding sequence contains a single ~250 bp long intron starting at nucleotide +135, as recognized by the conserved intron boundary sequence GT/AG. RT-PCR was performed to confirm the intron using primers P1 and P4 (Table 1) and the One-step RT-PCR kit (Quiagen, Crawley, UK) on 250 ng of NC4 total RNA. The deduced consensus DNA fragment has been confirmed by the finished *Dictyostelium* genome project as the gene DDB230174 (<http://dictybase.org>). Translation of the *DdADK* gene predicts a soluble, 340 amino acids long protein. Functional domains of the protein were predicted using the SMART program (<http://smart.embl-heidelberg.de>). Conservation of the functional domains was analyzed through multiple sequence alignments with the CLUSTALW program (<http://ebi.ac.uk/clustalw/>).

Gene constructs, PCR screening and cell transformations

To generate a gene disruption construct, two fragments of 460 bp and 440 bp respectively of the *DdADK* gene were amplified by standard PCR using Taq DNA polymerase (Promega, USA) on wild type AX2 genomic DNA. The oligonucleotides used were P1 and P2 that add a 5'-BamHI and 3'-EcoRI site to the 460 bp fragment and oligonucleotides P3 and P4,

that add a 5'-XbaI and a 3'-BamHI site to the 440 bp fragment (See Table 1 for primers sequences and Figure 5 for details). Both fragments were subsequently cloned in tandem into the BamHI/EcoRI and XbaI/BamHI sites of the pUC118Bsr Δ BamHI plasmid that harbours the blasticidin selection marker (Sutoh, 1993). The resulting construct was made linear by digesting it with BamHI, prior to transformation into *Dictyostelium* cells (Knecht et al., 1990). Homologous recombination of the linear construct with specific flanking sequences of the *ADK* gene will cause the integration of the entire plasmid, including the resistance cassette. Knockout clones were selected for growth with 5 μ g/ml blasticidin. Genomic DNA was isolated from transformed clones and screened for homologous recombination or random integration by two separate PCR reactions using primers P6 and P5 or P6 and P4 respectively (Table 1, Fig. 5). Two knockout clones (KO1 and KO2) and one random integrant (RI) were selected for further analysis. For analysis of prespore gene expression all three clones were transformed by electroporation (Knecht et al., 1990) with a fusion construct of the *PsA* prespore gene promoter and the LacZ reporter gene, *PsA-LacZ* (gift from Jeff Williams, University of Dundee, UK).

RNA isolation, Northern blotting and *in situ* hybridisations

To study the developmental regulation of *DdADK* expression, NC4 cells were incubated for 24 h on PB agar. Total RNA was isolated from 2×10^7 cells at 2 hours intervals. RNA was size fractionated on 1.5% agarose gels containing 2.2 M formaldehyde (Nellen et al., 1987) and transferred to a nylon membrane. As a probe for Northern Blot hybridisation a 460 bp *DdADK* DNA fragment was amplified by PCR using primers P3 and P4 (Table 1), radio-labelled with [32 P]-dATP (Amersham, UK) and hybridised as previously described (Sambrook et al., 1989).

For *in situ* hybridisation, 10^6 cells were spread on 1-cm² pieces of dialysis membrane, supported by PB agar and incubated at 22°C. After the desired developmental stages had been reached, membranes were transferred to a parafilm coated wet-box, where *in situ* hybridisation was carried out as previously described (Escalante and Loomis, 1995) using 250 ng of DIG-labelled RNA probes. For construction of the *DdADK*-RNA probe a 460 bp DNA fragment was amplified by PCR using primers P3 and P4 (Table 1) yielding a fragment with flanking XbaI/BamHI sites. This fragment was cloned into the XbaI and BamHI sites of pBluescript KS+ and subsequently used as template for the *DdADK* RNA probe using the T3 and T7 RNA polymerases and DIG-RNA labelling kit following the manufactures instructions (Roche, UK). Similarly, a 700 bp BamHI/HindIII fragment of the prespore specific gene *cotB* was cloned into compatible sites of the multiple cloning site of the Bluescript SK- vector (Stratagene, California, USA) (gift from Nick Oswald, University of Dundee, UK) and used to create the *CotB*-DIG-labelled probe.

Determination of number of cells per slug and analysis of slug size

Cells were harvested from exponentially growing cultures and resuspended in PB buffer at 2×10^8 cells/ml. Droplets of 10 μ l of cell suspension were deposited on 1.5% water agar. Cells were incubated at 22°C until slugs have formed. The droplet area was then photographed and the number of slugs per droplet was counted. The number of slugs per 10^6 cells and cells per slug was calculated from at least five droplets.

Adenosine kinase assay

Adenosine kinase activity was determined by measuring the conversion of 3 H-adenosine (Perkin Elmer Life Sciences, Boston, USA) into 3 H-5'AMP in the presence of ATP and Mg⁺². 50 μ l of either cleared cell lysate or secreted cell fraction samples were incubated in a final volume of 100 μ l with 10 μ l assay mix (1 mM ATP, 1 mM MgSO₄, 10 mM adenosine, 10^{-5} M 3 H-adenosine in 20 mM Tris pH 8.0). Samples were incubated for 20 min at 23°C. Reactions were stopped by addition of 30 μ l 0.1 M EDTA and boiling of the plate for 1 minute. The negatively charged 5'AMP was separated from adenosine by shaking 100 μ l of sample for

2 min with a 100 µl slurry of 1:1 diluted AG1x8-Dowex anion exchange resin (Biorad). The resin was precipitated by centrifugation for 2 min at 663 x g and the supernatant discarded. The resin was washed twice with 1 ml of 10% methanol by shaking tubes for 30 seconds and centrifugation at 663 x g for 1 minute. To elute the bound ^3H -5'AMP, samples were shaken for 5 min with 0.5 ml of 2 M NaCl. Samples were centrifuged at 663 x g for 2 min and the supernatant was recovered, mixed with scintillation cocktail and measured by liquid scintillation counting.

Assay for secreted and cell associated adenosine kinase activity in slugs

Cells were incubated on PB agar at 7×10^6 cells/cm² at 22°C until slugs were formed. Slugs were harvested, washed and dissociated by vigorous pipetting in 20 mM Tris pH 8.0 (TB). The cell density was adjusted to 10^7 cells/ml, and 2 ml of cell suspension were shaken for 1 h at 150 rpm and 22°C. Samples were centrifuged 2 min at 1125 x g. The supernatant was separated from the pellet and placed on ice; the pellet was then resuspended in 2 ml TB, and lysed through Nucleopore filters (pore size, 3 µM). Both supernatant and cell lysate were subsequently assayed for adenosine kinase activity. Protein levels of all cell lysates and extracts were measured using the Bradford assay and used to standardize adenosine kinase activities.

Developmental time course of accumulated and newly produced adenosine kinase activity

10^8 cells were plated on 2 cm² nitrocellulose filters placed on 2.5 cm² pieces of Whatman paper drenched in 5 mM PB pH 6.5, on PB agar plates. Plates were incubated in a wet box at 22°C over a 24 h period. Every two hours a filter sandwich was transferred to 2 ml of ice-cold TB and vortexed for 15 seconds. The liquid fraction was transferred to a fresh tube and the remaining filters were washed once more with 2 ml TB. The combined washes were centrifuged for 2 min at 720 x g. The supernatant ("accumulated" fraction) was transferred to a fresh tube and kept on ice until assayed for adenosine kinase activity. The pellet containing the developing cells was washed once more and finally resuspended in 1.2 ml TB. One ml was shaken for 20 min at 150 rpm and 22°C and subsequently centrifuged for 2 min at 720 x g. The supernatant fraction was then recovered as the freshly "produced" fraction and assayed alongside with the "accumulated" fraction for adenosine kinase activity.

Prespore induction assay

Cells transformed with the *PsA-LacZ* construct were starved on PB agar until loose mounds had formed. Cells were subsequently harvested and resuspended to 3×10^6 cell/ml in PB. Aliquots of 90 µl of cell suspension were incubated in a total volume of 100 µl with 30 µM SpcAMPS (Biolog, Germany) and variable adenosine (Sigma, USA) concentrations (0, 10^{-5} M, 3×10^{-5} M, 10^{-4} M, 3×10^{-4} M, 10^{-3} M, 3×10^{-3} M). Cell suspensions were intermittently (10s on/1s off) shaken for 8 hours at 800 min⁻¹ rpm and 22°C. Cells were lysed for spectrophotometric measurement of β-galactosidase activity by two freeze-thawing cycles whilst vigorously shaking (Schaap et al., 1993). 30 µl of 2.5x Z-buffer (150 mM Na₂HPO₄, 100 mM NaH₂PO₄, 25 mM KCl, 25 mM MgSO₄, 5 mM MgCl₂ and 1% 2-β-mercaptoethanol, pH 7.0) and 10 µl of ortho-nitrophenyl-β-galactoside (ONPG) (Sigma, USA) were added to the cell lysates and the OD₄₅₀ was measured at regular time intervals using a microtiter plate reader.

Table 1: Oligonucleotides used in this work

P1	TCATGGATTCCACTCACTAAAATGTCAAACATTTAAAATTCTTTGCGC
P2	CAGTGAATTCGTGAACAGCAGAGTCTGGTGAACGG
P3	TGACTCTAGACCATTCTCTACGGTTTAGCCGC
P4	GACCGGATTCGGCTGGGACGGTGGCACCATTTGTGTC
P5	CACAAGATCCCTCAGGTAGAGC
P6	GATTTGATGGGATTAATTAATTTGTAATC
P7	GTGGTGCTGCACAAAATACATCACGTC

Results

Dictyostelium adenosine kinase gene sequence and protein analysis

The sequence for the *Dictyostelium* adenosine kinase gene was obtained by reiterated query of single sequence runs of the ongoing *Dictyostelium* Japanese cDNA and genomic sequencing projects using the rat adenosine kinase sequence. Initial hit sequences were assembled into a final consensus sequence for the *Dictyostelium* adenosine kinase homologue gene, *DdADK*. The recently finished *Dictyostelium* genome has shown that the deduced sequence corresponds to the gene *DDB230174*. The adenosine kinase *DdADK* gene is positioned on chromosome 4 and shares 37% amino acid sequence identity with the human and rat adenosine kinases. The *DdADK* DNA coding region is 1280 nucleotides long and carries a single intron (Fig. 2A).

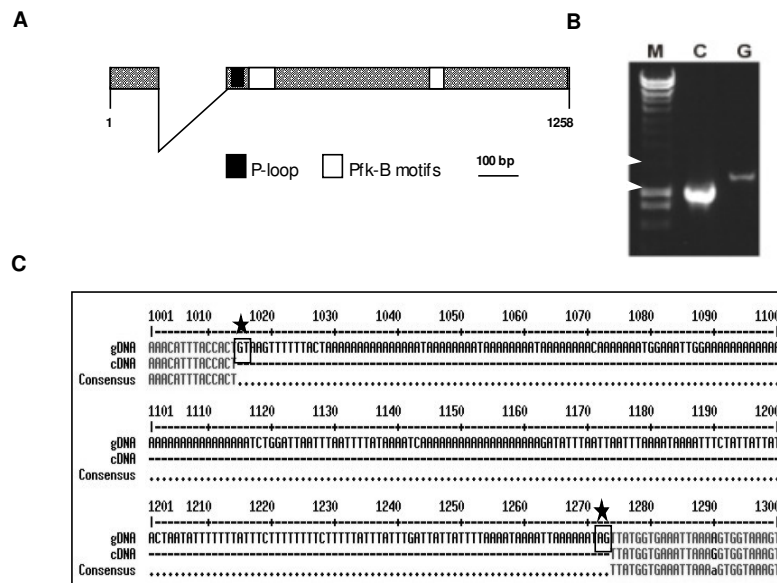

Figure 2. Structure of the *Dictyostelium* ADK gene

(A) Schematic representation of the *DdADK* gene. Solid boxes represent the two exons (134 and 888 bp long respectively), separated by a single 258 bp intron. The conserved domains ATP binding P-loop (solid box) and sugar kinase (PfkB family) homologous motifs (white boxes) are shown (See text for details). (B) Amplification of *DdADK* gene by RT-PCR was performed on AX2 cells RNA at 4 hours of development, using primers P1 and P4 (Table 1), yielding a 1 kb cDNA. The same set of primers was used in a PCR reaction on AX2 genomic DNA yielding the 1.25 kb expected genomic band. Both PCR and RT-PCR products were run alongside for size comparison on 1% agarose gel stained with ethidium bromide. The size difference between the cDNA and the genomic bands confirms the existence of a ~250 bp intron. As a reference, arrowheads mark the position of 1.5 kb and 0.8 kb bands on the DNA marker (M = 1 kb molecular marker; c = RT-PCR cDNA; g = PCR genomic DNA). (C) Alignment of sequences from the genomic PCR and the RT-PCR products further proved the position of the 258 bp intron and conserved intron boundary (GT/AG). The intron boundary is boxed and marked with a star. This is the result of one sequence run using primers P1 and P4 (Table 1).

Amplification of the gene by RT-PCR using RNA from NC4 cells confirms the presence of a 258 bp intron, yielding the expected 1023 bp cDNA fragment. A second PCR reaction on wild type genomic DNA using the same set of primers performed as control yielded the expected 1280 bp (Fig.2B). Sequencing of the RT-PCR product provided further evidence of the presence of the intron starting at nucleotide number 135 and revealed the presence of the conserved intron boundary represented by the nucleotide sequence GT/AG (Fig. 2C)

The deduced protein sequence is 340 amino acids long and topology analysis performed with the SMART program suggest that it has no putative transmembrane domains and is therefore a soluble protein (Fig. 3A). *DdADK* protein is homologous to the rat and human adenosine kinases and they all share homology to conserved domains found in sugar kinases of yeast, plants and lower eukaryotes (Szychala et al., 1996). Alignment of the predicted protein sequence with some of these homologous sequences highlights the principal motifs found in other adenosine kinases, fructokinases and microbial ribokinases (Fig. 3B). The conserved N-terminal P-loop that is essential for ATP/GTP binding in most kinases is also conserved in all aligned enzymes. However, in *Dictyostelium* ADK there is a transition from a

pattern appears during culmination showing very strong and specific expression of the gene in the upper and lower cups of culminants (Fig. 4C2).

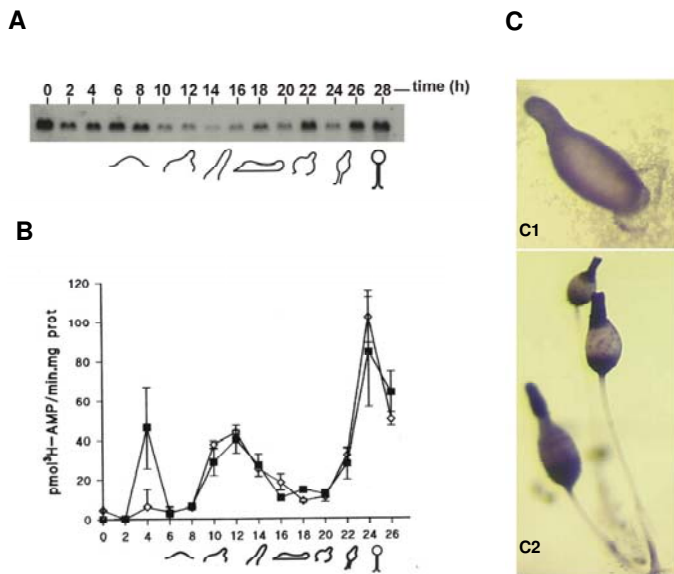

Figure 4. Developmental regulation and pattern of adenosine kinase

(A) Wild type NC4 cells were let to develop until fruiting bodies had formed on non-nutrient agar. Total RNA was extracted every two hours, size fractionated, blotted and hybridised with a [³²P]-dATP-labelled *DdADK* DNA probe. (B) AX2 cells were incubated on nitrocellulose filters supported on PB-drenched Whatman paper on PB agar. Cells and Whatman paper were collected every two hours and the levels of both produced and accumulated 5'-AMP were determined as measurement of adenosine kinase activity. Means and SE of one experiment performed in triplicate are shown. All data were standardized on protein content of the extracellular suspension. Closed symbols: produced activity; Open symbols: accumulated activity. (See methods for details). (C) AX2 cells were let to develop on 1 cm² dialysis membranes supported by PB agar. *DdADK* pattern was visualized by *in situ* hybridisation in fingers (C1) and late culminants (C2) using a specific *DdADK* DIG-labelled-RNA probe.

Disruption of the *DdADK* gene

To understand the role of ADK in *Dictyostelium* development the *DdADK* gene was inactivated by homologous recombination and insertion of the blasticidin resistance cassette, in the wild type strain AX2 (Fig. 5A). Screening for positive clones was performed using at least two independent PCR reactions as shown in Figure 5B, and Southern blotting (not shown). Two independent knockout clones (KO1 and KO2) and one random integrant clone (RI) obtained from the same transformation were selected and used for further phenotypic analysis.

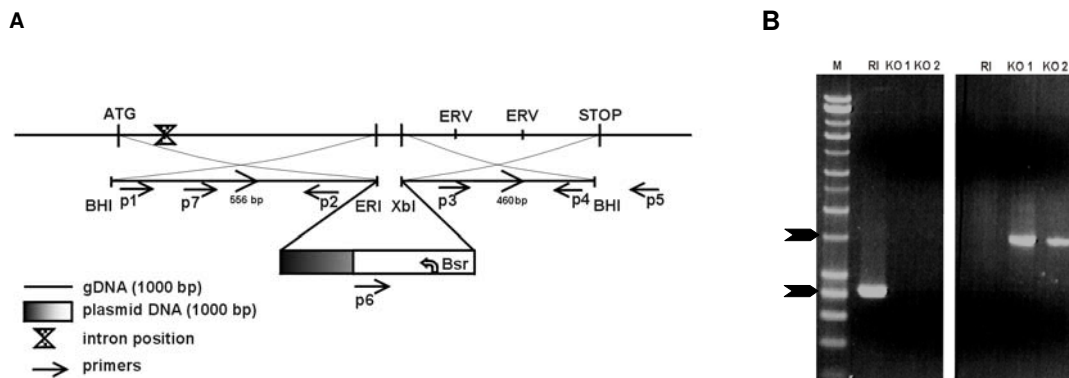

Figure 5. Gene disruption and screening of knockout clones

(A) Schematic representation of the *DdADK* gene knockout construct. The blasticidine resistance cassette (Bsr) is inserted into the gene by homologous recombination. Primers used to make the knockout construct and later PCR screening of knockout clones are represented by P1 to P7 (See Table 1 for sequences). Restriction sites are marked as: BHI: BamHI, ERI: EcoRI, XbaI: XbaI, ERV: EcoRV. (B) At least two separate PCR reactions were performed in the screening of knockout clones. PCR1 was performed using primers P7 and P4 yielding a 0.8 kb fragment corresponding to a wild type band, which is present in the random integrant clone, RI. PCR2 shows the band obtained with primers P5 and P6 that is only present when specific disruption of the gene has taken place. This band is present in the knockout clones, KO1 and KO2, and absent in the RI clone. Arrowheads mark the positions of 1.5 and 0.8 kb on DNA marker.

Analysis of the ADK null (*adk*) mutant phenotype.

ADK controls the levels of nucleotides and could potentially interfere with basic cellular metabolism. However, the KO strains do not show any growth defects (data not shown). The null mutant also displayed normal aggregation and development of slugs and fruiting bodies. Any adenosine kinase activity should be lost in this cell line and Figure 6 shows that in slugs both the cell-associated and secreted adenosine kinase activities are about four-fold reduced in the two null-mutant clones. This demonstrates that most of the *Dictyostelium* adenosine kinase activity is due to DdADK.

Figure 6. Absence of adenosine kinase activity on *Ddadk* knockouts

Knockout clones KO1 and KO2, a control random integrant (RI) and AX2 cells were let to develop into slugs on non-nutrient agar. Disaggregated slug cells were resuspended in 20 mM Tris at a density of 3×10^7 cells/ml and shaken at 150 rpm for 1h at 22°C. Cells were then collected by centrifugation and separated from the supernatant. The remaining cells were resuspended in fresh 20 mM Tris and lysed through Nucleopore filters. Both supernatant and lysate dilutions were assayed in triplicate in the presence of saturating concentrations of ATP/Mg, and 10^{-6} M ^3H -adenosine for 20 min at 22°C. Final adenosine kinase activity was calculated by measuring the levels of newly formed ^3H -5'AMP after being separated from ^3H -adenosine by anion exchange chromatography. Extracellular (A) and cell associated (B) adenosine kinase activities are shown as means and SEM of at least three experiments performed in triplicate. All assays were standardised on total protein content.

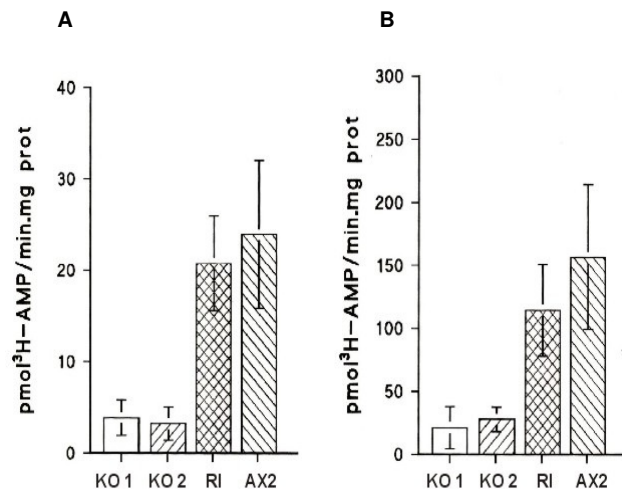

Extracellular levels of adenosine have been reported to modulate slug size and cell type proportions (Wang and Schaap, 1985). Slug size is largely determined by the number of tips appearing on aggregates with each tip directing the formation of a single slug. Every tip produces cAMP pulses autonomously and secretes a compound that inhibits formation of competing oscillators. Adenosine has been put forward as a likely candidate to play this inhibiting role. Since DdADK is active also extracellularly it could be potentially controlling extracellular levels of adenosine and therefore slug size. We measured the number of slugs that were formed from a known number of cells placed at close proximity in a small droplet. Figure 7A shows that *adk* cells formed less than half the number of slugs from 10^6 cells as the control line and these slugs were consequently more than two times larger. From this experiment we can conclude that adenosine plays a role in controlling slug size, although the levels of extracellular adenosine should be measured to validate this affirmation.

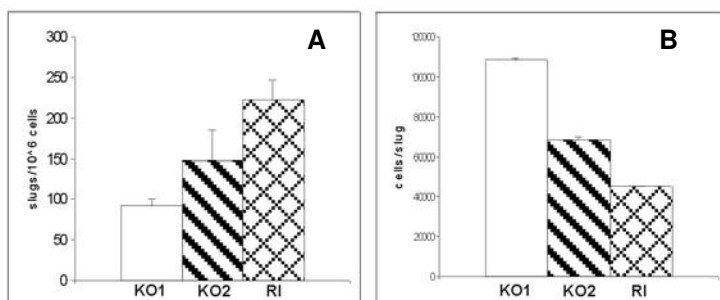

Figure 7. Calculation of slug size and number of cells per slug

Droplets of cell suspensions of the *adk* KO1 and KO2, and of one random integrant used as control were deposited on water agar and allowed to develop at 22°C. Once slugs were formed, they were photographed and counted. The number of slugs per 10^6 cells (A) and number of cells per slug are shown (B).

Adenosine has also been proposed to be an inhibitor of prestalk differentiation in the prestalk region of slugs (Schaap and Wang, 1986). However, millimolar concentrations of adenosine are required to have a significant effect and it is questionable whether these concentrations can be reached by degradation cAMP. Yet it is possible that active phosphorylation of adenosine by ADK obscures the actual local adenosine concentration. If adenosine

has a role in prespore differentiation, inhibition of prespore induction in the *adk*⁻ cells will be hypersensitive to adenosine. Additionally we will expect the knockout to show a reduction in size of the prespore region of the slug. To test for adenosine hypersensitivity, *adk*⁻ and RI cells were transformed with a β -galactosidase reporter construct under the prespore specific *PsA* promoter (*PsA-LacZ*). This yielded the cell lines KO1/*PsA-LacZ* and RI/*PsA-LacZ*. Aggregation competent cells of the transformed strains were then incubated with 30 μ M SpcAMPs and increasing concentrations of adenosine during a period of 8 hours. Figure 8A shows that *PsA* promoter activity was induced by SpcAMPs and inhibited by all concentrations of adenosine with equal efficiency in both cell lines.

The pattern of prespore gene expression was visualized by *in situ* hybridisation in *adk*⁻ and random integrant clones using the prespore gene *CotB* as a probe (Fig. 8B). No significant differences in the proportional size of the prespore region were found between the knockouts and control cell lines. This suggests that loss of adenosine kinase does not have a major effect on prespore expression in slugs.

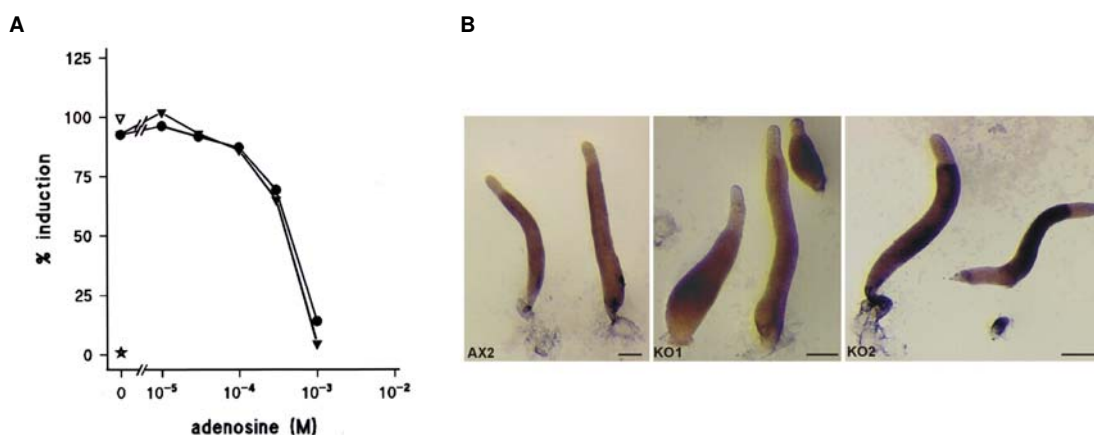

Figure 8. Inhibition of prespore induction by adenosine and prespore pattern in *DdADK* knockouts

(A) Knockout clones and the control random integrant were transformed with the prespore specific construct *PsA-LacZ*. Transformed lines were let to develop to loose mounds, harvested, and resuspended to 3×10^6 c/ml. Cell suspensions were incubated in the presence of 30 μ M SpcAMPs and increasing concentrations of adenosine during 8 hours. 30 μ M SpcAMPs alone was used as a positive control. Prespore induction was measured by spectrophotometric methods following the activity of the reporter *PsA-LacZ* on cell lysates using ONPG as a substrate. (Star: no treatment; Open triangle: 30 μ M SpcAMPs; Closed triangle: RI; Closed circle: *adk*⁻). (B) *In situ* hybridisation to a prespore specific DIG-labelled-*cotB* riboprobe was performed on slugs of *adk*⁻, RI and wild type strains.

Discussion

We have identified the gene for an adenosine kinase (*DdADK*) by screening the *Dictyostelium* genomic and Japanese cDNA databases. *DdADK* is highly conserved and it is homologous to the human and yeast adenosine kinases and to enzymes of the phospho-fructo kinase B (PfkB) family. PfkB proteins are involved in pathways of carbohydrate metabolism such as glycolysis, and share with adenosine kinases the motifs for ATP binding and pentose recognition. All adenosine kinases analysed are closer to this sugar kinases than to other nucleoside kinases such as uridine or thymidine kinases. This might suggest that a sugar kinase might have been recruited at some point during evolution to synthesise nucleotides as a different function. Analysis of the predicted topology of the protein suggests that *DdADK* does not have any signalling peptide for subcellular localization or transmembrane domains, so it is likely to be a soluble protein and I have shown that cell-associated and extracellular adenosine kinase activities are present at significant levels throughout development. However, the mechanism of secretion is yet unknown.

DdADK is developmentally regulated, with two peaks of maximal expression, one during the first hours of development and the second one after 18-20 hours. On the other hand, the maximal secreted and cell-associated kinase activities are found between 10 and 12 hours and between 22 and 24 hours, showing a shift of four to six hours in relation to the gene

transcription. This might be due to translational regulation of the protein or enzyme regulation. A similar discrepancy between mRNA levels and levels of enzymatic expression has been observed in the human adenosine kinase. The human ADK is widely distributed among tissues. However, there are cases such as the brain in which the high levels of ADK activity detected do not correlate to the low levels of mRNA found in this tissue (Spychala et al., 1996).

DdADK is specifically expressed at the upper and lower cups in culminants. This pattern of expression is related to that of *5'NT* and the alkaline phosphatase that also degrades 5'AMP to adenosine, *ALP*. *5'NT* is specifically expressed at the lower cup and stalk in late culminants whereas the *ALP* is found in the boundary between prespore and prestalk cells in slugs and its expression becomes specific of the upper and lower cups in culminants. These results point at the prespore/prestalk boundary in the slug and later in culminants, as important signalling centres from which cell differentiation and movement might be controlled.

The *DdADK* knockouts show normal growth and development, but form significantly larger slugs when compared to wild type, indicating that fewer tips are formed in each aggregation field. Null mutants in 5' nucleotidase, the enzyme that produces adenosine, show an opposite phenotype with multi-tipped aggregates and consequently much smaller slugs (Rutherford et al., 2003). Taken together, these results support the hypothesis that adenosine mediates tip dominance and thereby controls slug size (Newell and Ross, 1982; Schaap and Wang, 1986).

Treatment of aggregation competent cells with concentrations of adenosine in the millimolar range inhibits the expression of the prespore specific genes *psA* and *cotC* (Verkerke-VanWijk et al., 1998), which suggests that extracellular adenosine plays an important role controlling prespore induction. The lack of the kinase activity in the knockouts would potentially lead to an increase in the levels of intra- and more importantly, extracellular adenosine. The consequences of this in terms of prespore expression in slugs are that the total levels of prespore expression would be greatly reduced in the knockouts, showing a smaller prespore area. Furthermore, less adenosine would be required to inhibit induction of prespore genes. The data presented here cannot support these predictions. I have not observed any significant reduction or alteration on prespore pattern in slugs as seen by *in situ* hybridisation. Inhibition of prespore gene induction is also not altered in the *adk* null strain. This does not exclude the possibility of alternative pathways that might take over controlling prespore expression in the *adk* null strain and that would require further investigation.

As a final conclusion, these results tend to support a role for adenosine in the regulation of slug size but I have found no evidence to support a role for extracellular adenosine in the establishment of prespore/prestalk pattern.

References

1. Alvarez-Curto, E., Weening, K. E., and Schaap, P. (2006). Pharmacological profiling of the *Dictyostelium* adenylate cyclases ACA, ACB and ACG. *Biochem J* 401, 309-16.
2. Dormann, D., and Weijer, C. J. (2001). Propagating chemoattractant waves coordinate periodic cell movement in *Dictyostelium* slugs. *Development* 128, 4535-4543.
3. Escalante, R., and Loomis, W. F. (1995). Whole-mount in situ hybridization of cell-type-specific mRNAs in *Dictyostelium*. *Dev Biol* 171, 262-266.
4. Fredholm, B. B., IJzerman, A. P., Jacobson, K. A., LKlotz, K. N., and Linden, J. (2001). International Union of Pharmacology. XXV Nomenclature and Classification of Adenosine Receptors. *Pharm Rev* 53, 527-552.
5. Johnson, R. A., Yeung, S. M., Stubner, D., Bushfield, M., and Shoshani, I. (1989). Cation and structural requirements for P site-mediated inhibition of adenylate cyclase. *Mol Pharmacol* 35, 681-688.
6. Kay, R. R., and Thompson, C. R. (2001). Cross-induction of cell types in *Dictyostelium*: evidence that DIF-1 is made by prespore cells. *Development* 128, 4959-4966.
7. Knecht, D. A., Jung, J., and Matthews, L. (1990). Quantification of transformation efficiency using a new method for clonal growth and selection of axenic *Dictyostelium* cells. *Dev Genetics* 11, 403-409.
8. Londos, C., and Wolff, J. (1977). Two distinct adenosine-sensitive sites on adenyl cyclase. *Proc Natl Acad Sci U S A* 74.
9. Nellen, W., Datta, S., Reymond, C., Sivertsen, A., Mann, S., Crowley, T., and Firtel, R. A. (1987). Molecular Biology in *Dictyostelium*: Tools and applications. In *Methods in Cell Biology*, J. A. Spudich, ed. (Orlando, FL, Academic Press), pp. 67-100.
10. Newell, P. C. (1982). Cell surface binding of adenosine to *Dictyostelium* and inhibition of pulsatile signalling. *FEMS Microbiol Lett* 13, 417-421.
11. Newell, P. C., and Ross, F. M. (1982). Inhibition by adenosine of aggregation centre initiation and cyclic AMP binding in *Dictyostelium*. *J Gen Microbiol* 128, 2715-2724.
12. Rutherford, C. L., Overall, D. F., Ubeidat, M., and Joyce, B. R. (2003). Analysis of 5' nucleotidase and alkaline phosphatase by gene disruption in *Dictyostelium*. *Genesis* 35, 202-213.
13. Sambrook, J., Fritsch, E. F., and Maniatis, T. (1989). *Molecular cloning: A laboratory manual* (New York, Cold Spring Harbour Laboratory Press.).
14. Schaap, P. (1986). Regulation of size and pattern in the cellular slime molds. *Differentiation* 33, 1-16.
15. Schaap, P., Van Ments-Cohen, M., Soede, R. D. M., Brandt, R., Firtel, R. A., Dostmann, W., Genieser, H.-G., Jastorff, B., and VanHaastert, P. J. M. (1993). Cell-permeable non-hydrolyzable cAMP derivatives as tools for analysis of signaling pathways controlling gene regulation in *Dictyostelium*. *J Biol Chem* 268, 6323-6331.
16. Schaap, P., and Wang, M. (1984). The possible involvement of oscillatory cAMP signaling in multicellular morphogenesis of the cellular slime molds. *Dev Biol* 105, 470-478.
17. Schaap, P., and Wang, M. (1986). Interactions between adenosine and oscillatory cAMP signaling regulate size and pattern in *Dictyostelium*. *Cell* 45, 137-144.
18. Sinha, K. M., Ghosh, M., Das, I., and Datta, A. K. (1999). Molecular cloning and expression of adenosine kinase from *Leishmania donovani*: identification of unconventional P-loop motif. *Biochem J* 339, 667-673.
19. Spychala, J., Datta, N. S., Takabayashi, K., Datta, M., Fox, I. H., Gribbin, T., and Mitchel, B. S. (1996). Cloning of human adenosine kinase cDNA: sequence similarity to microbial ribokinases and fructokinases. *Proc Natl Acad Sci USA* 93, 1232-1237.
20. Sutoh, K. (1993). A transformation vector for *Dictyostelium discoideum* with a new selectable marker bsr. *Plasmid* 30, 150-154.
21. Theibert, A., and Devreotes, P. (1984). Adenosine and its derivatives inhibit the cAMP signaling response in *Dictyostelium discoideum*. *Dev Biol* 106, 166-173.
22. Van Haastert, P. J. M., and Kien, E. (1983). Binding of cAMP derivatives to *Dictyostelium discoideum* cells. Activation mechanism of the cell surface cAMP receptor. *J Biol Chem* 258, 9636-9642.
23. Van Lookeren Campagne, M. M., Schaap, P., and Van Haastert, P. J. M. (1986). Specificity of adenosine inhibition of cAMP-induced responses in *Dictyostelium* resembles that of the P site of higher organisms. *Dev Biol* 117, 245-251.
24. Verkerke-VanWijk, I., Kim, J. Y., Brandt, R., Devreotes, P. N., and Schaap, P. (1998). Functional promiscuity of gene regulation by serpentine receptors in *Dictyostelium discoideum*. *Mol Cell Biol* 18, 5744-5749.
25. Wang, M., and Schaap, P. (1985). Correlations between tip dominance, prestalk/prespore pattern, and cAMP-relay efficiency in slugs of *Dictyostelium discoideum*. *Differentiation* 30, 7-14.
26. Weijer, C. J., and Durston, A. J. (1985). Influence of cyclic AMP and hydrolysis products on cell type regulation in *Dictyostelium discoideum*. *J Embryol Exp Morph* 86, 19-37.

