



Universiteit
Leiden
The Netherlands

A grammar of the Thangmi language with an ethnolinguistic introduction to the speakers and their culture

Turin, M.

Citation

Turin, M. (2006, May 17). *A grammar of the Thangmi language with an ethnolinguistic introduction to the speakers and their culture*. Retrieved from <https://hdl.handle.net/1887/4458>

Version: Corrected Publisher's Version

License: [Licence agreement concerning inclusion of doctoral thesis in the Institutional Repository of the University of Leiden](#)

Downloaded from: <https://hdl.handle.net/1887/4458>

Note: To cite this publication please use the final published version (if applicable).

Cover Page



Universiteit Leiden



The handle <http://hdl.handle.net/1887/4458> holds various files of this Leiden University dissertation.

Author: Turin, Mark

Title: A grammar of the Thangmi language with an ethnolinguistic introduction to the speakers and their culture

Issue date: 2006-05-17

APPENDICES

Thangmi kinship terms for offspring in Sindhupālcok

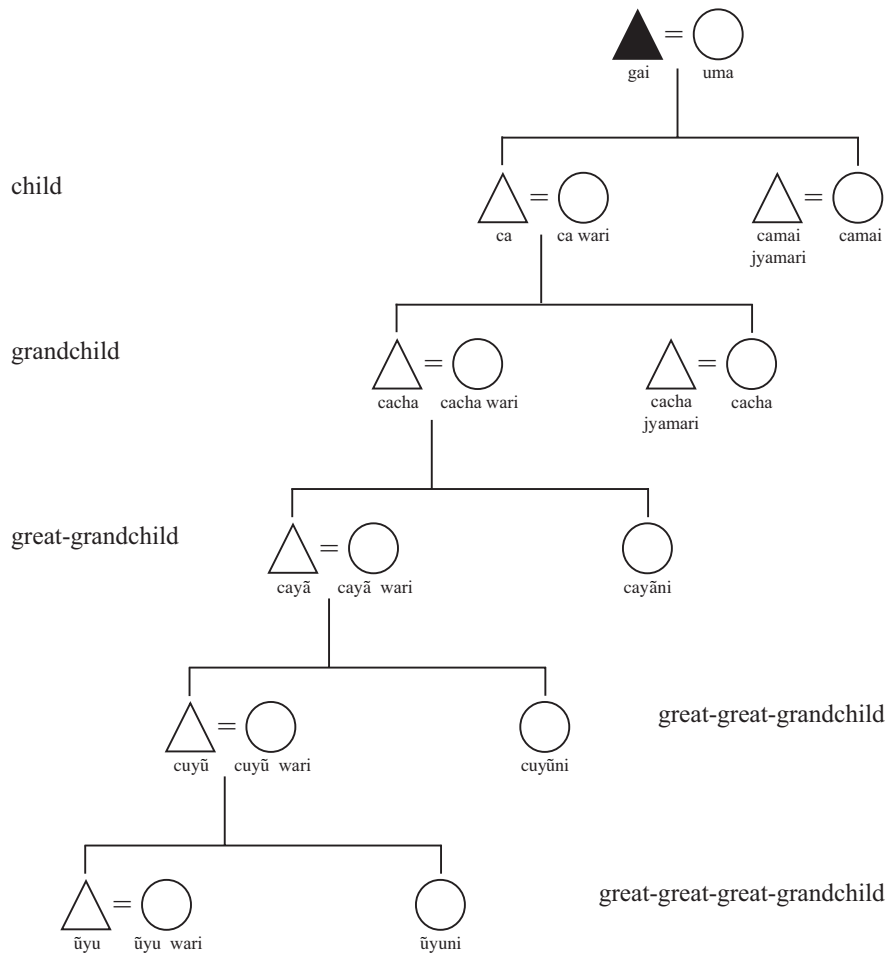

Female ego Thangmi male in-law alliance in Sindhupālcook

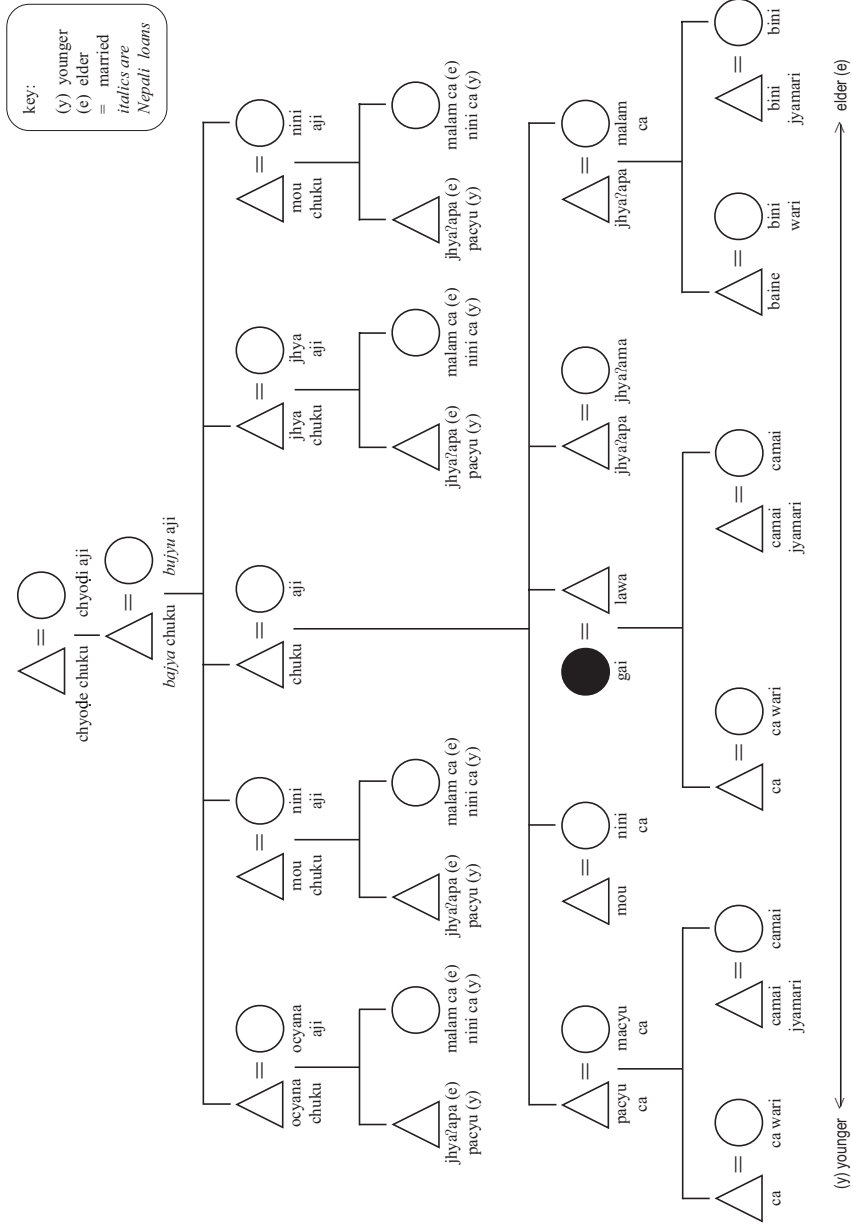

Thangmi male in-law alliance in Sindhupālcok

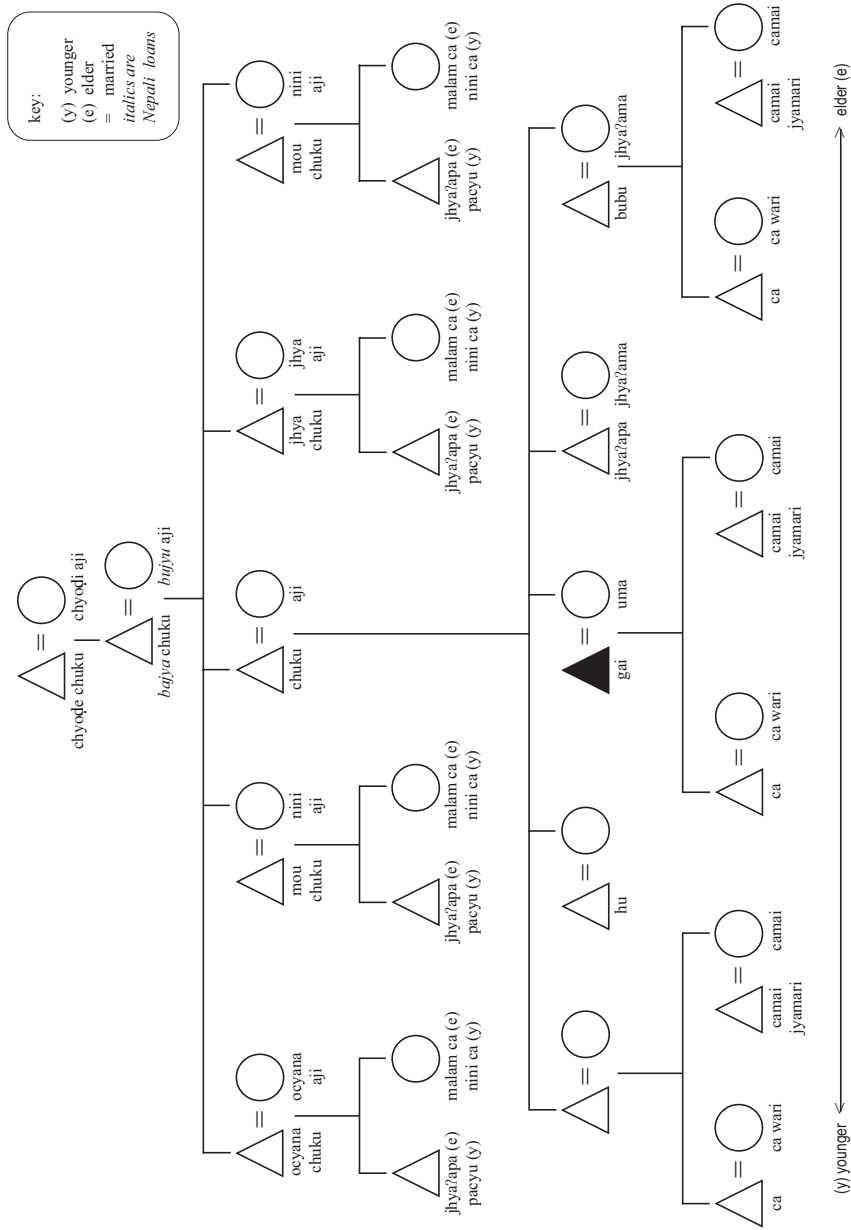

Male ego Thangmi sisters-in-law in Dolakhā

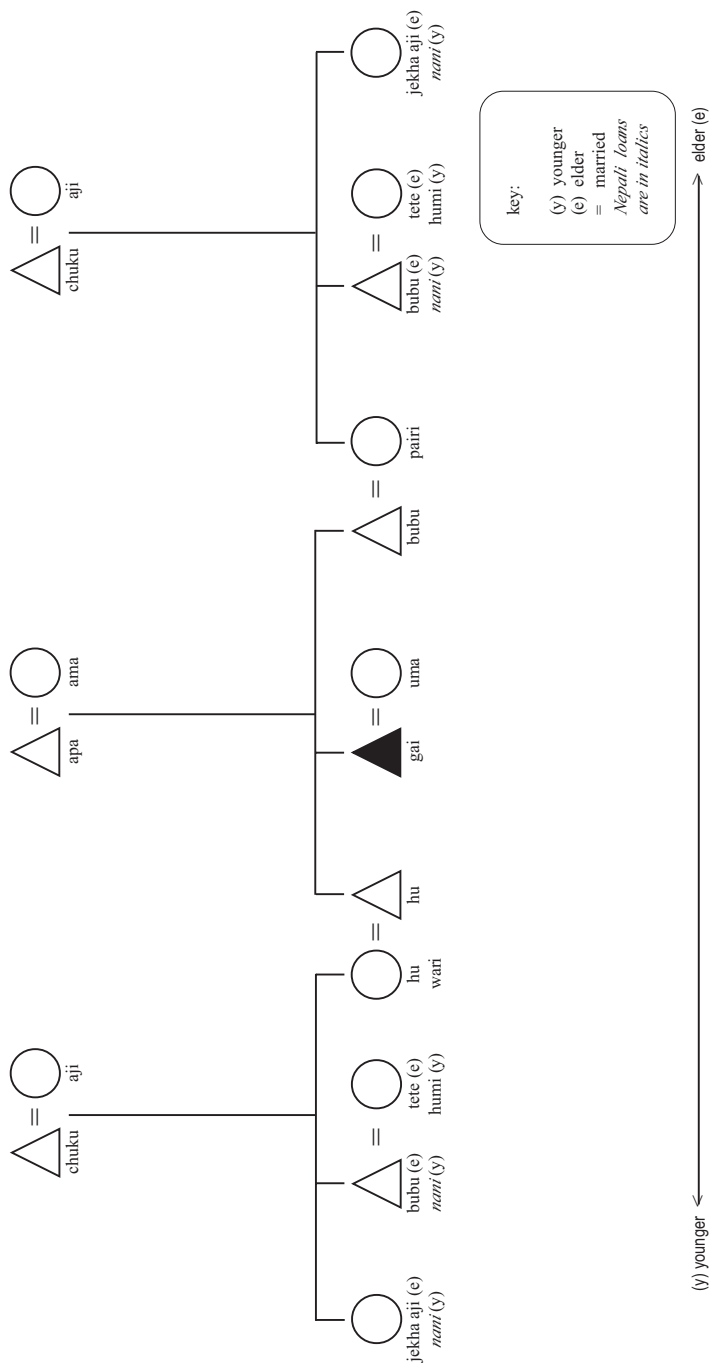

Male ego Thangmi brothers-in-law in Dolakhā

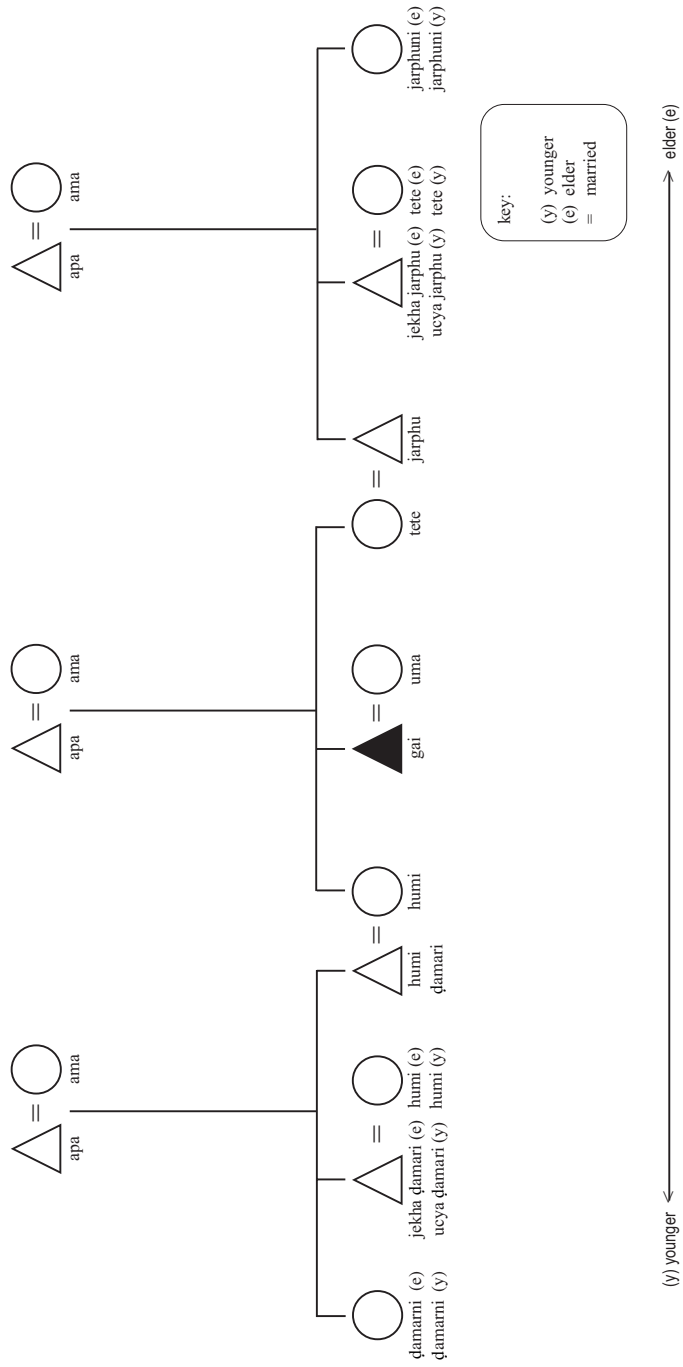

Thangmi female in-law alliance in Dolakhā

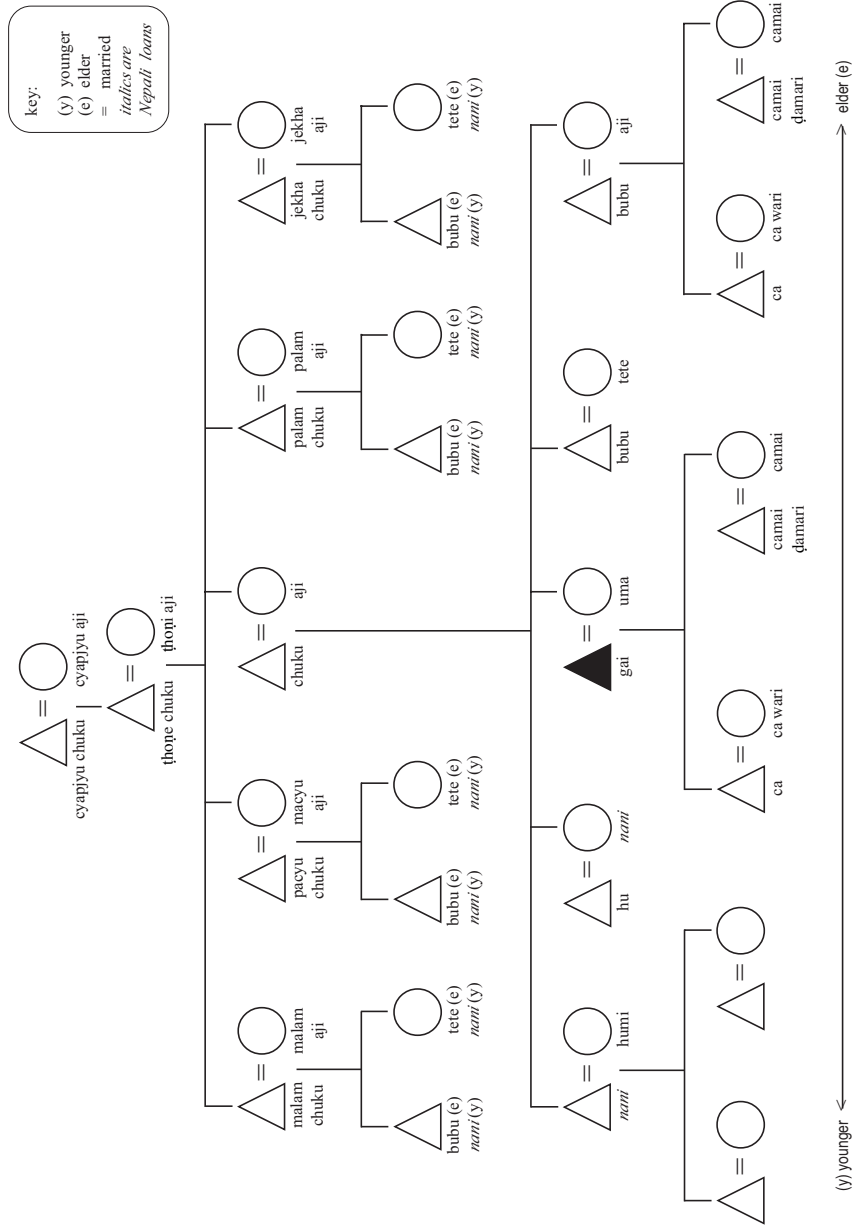

BIBLIOGRAPHY

For publications dated in the Nepalese Vikram Saṃvat era (VS), I provide the year of publication in the Gregorian calendar (AD) between parentheses. A year in Vikram Saṃvat overlaps two Gregorian calendar years, e.g. VS 2058 (i.e. AD 2001-02).

- Acharya, Madhu Raman [i.e. Madhuramaṇ Ācārya]. 1994. *Nepal Encyclopedia: A Concise Encyclopedia of the Facts and Knowledge about the Kingdom of Nepal*. Kathmandu: Nepal Encyclopedia Foundation.
- Adhikārī, Rām Lāl. 1997. *Thaminī Kānchī*. Kāthmāṇḍu, Nepāl: Bhānu Prakāśan.
- Allen, Nicholas J. 1975. *Sketch of Thulung Grammar: With Three Texts and a Glossary* (East Asia Papers No. 6). Ithaca: Cornell University.
- Amnesty International. 1987. *Nepal: A Pattern of Human Rights Violations*. New York: Amnesty International Publications.
- Anonymous. 1994. 'Nepal: Ripe for harvest: An unreached people eager to hear of Christ', *Sounds of Gospel Recordings*, Spring 1994: 1-2.
- Anonymous. 1997. 'Monkey duty keeps Thami children out of school', *The Kathmandu Post* (Thursday, May 29, 1997), v (100): 2.
- Anonymous. 1998. 'Thamis observe Dashain beyond their means', *The Kathmandu Post* (Thursday, October 15, 1998), vi (234): 2.
- Anonymous. 2000. 'Thami villagers revel as electricity comes to their homes', *The Rising Nepal* (Monday, December 25, 2000), xxxvi (10): 7.
- Anonymous. 2001a. 'Dolakha DEO to publish book on Thami community', *The Kathmandu Post* (Sunday, November 18, 2001), ix (268): 3.
- Anonymous. 2001b. 'Govt urged to bring out plan for Thamis', *The Rising Nepal* (Tuesday, September 4, 2001), xxxvi (263): 3.
- Anonymous. VS 2057(a) Vaiśākh 28 gate (i.e. Wednesday, May 10, 2000). 'Daḍuvākā Thāmīharū Śikṣā ra Cetanāmā Pachāḍī', *Gorkhapatra*, c (5): 16.
- Anonymous. VS 2057(b) Vaiśākh 31 gate (i.e. Saturday, May 13, 2000). 'Thāmīharū Anna Pākepachi Mātra Āphantako Kiriya Garchan' *Kāntipur*, viii (85): 13.
- Anonymous. VS 2058 (i.e. AD 2001-02). 'Āyasrot Nabhae Pani Dherai Bāl Baccā Janmāuchan Thāmīharū', *Surya Sāptāhik*.
- Ashley, Leonard R. N. 1993. 'Canada's Amerindians: Democracy, Demography and the Geolinguistics of Ethnicity', pp. 242-249 in Jesse Levitt, Leonard R. N. Ashley and Kenneth H. Rogers, eds., *Language in Contemporary Society: Proceedings of the International Conference on Geolinguistics*. New York: The American Society of Geolinguistics.
- Ballinger, Thomas O. 1973. 'Simraongarh revisited: A report on some observations made at the ruins of the former capital of Mithila in the Terai of Nepal', *Kailash*, i (3): 180-184.

- Bandhu, Cūḍā Maṇi. vs 2024 (i.e. AD 1967-68). *2024 Sālmā Tribhuvan Viśvavidyālayabāṭa bhaeko Bhāṣā Sarvekṣaṇa Kāryako Prativedan*. Kāthmāṇḍu: Nepālī Vibhāg, Tribhuvan Viśvavidyālaya. 38 pages.
- Bell, Charles Alfred. 1920. *English-Tibetan Colloquial Dictionary*. Second Edition. Calcutta: The Bengal Secretariat Book Deposit.
- Benedict, Paul King. 1941. 'Tibetan and Chinese kinship terms', *Harvard Journal of Asiatic Studies*, 6: 313-37.
- Benedict, Paul King. 1972. *Sino-Tibetan: A Conspectus*. Cambridge: Cambridge University Press.
- Berlin, Brent and Paul Kay. 1969. *Basic Color Terms: Their Universality and Evolution*. Berkeley: University of California Press.
- Beyer, Steven V. 1992. *The Classical Tibetan Language*. Albany: State University of New York Press (SUNY).
- Bhaskararao, Peri and S. K. Joshi. 1985. 'A study of Newari classifiers', *Bulletin of the Deccan College Research Institute*, 44: 17-31.
- Bista, Dor Bahadur. 1967. *People of Nepal*. Kathmandu: Department of Publicity, Ministry of Information and Broadcasting, His Majesty's Government of Nepal.
- Bista, Dor Bahadur. 1991. *Fatalism and Development: Nepal's Struggle for Modernization*. Calcutta: Orient Longman.
- Blake, Barry J. 1994. *Case*. Cambridge: Cambridge University Press.
- Breton, Roland J. L. 1991. *Geolinguistics: Language Dynamics and Ethnolinguistic Geography*. Translated and expanded by Harold F. Schiffman. Ottawa: University of Ottawa Press.
- Breton, Roland J. L. 1993. 'The drastic reduction among culture languages in the world of today and in the future', pp. 1-13 in Jesse Levitt, Leonard R. N. Ashley and Kenneth H. Rogers, eds., *Language in Contemporary Society: Proceedings of the International Conference on Geolinguistics*. New York: The American Society of Geolinguistics.
- Caplan, Lionel. 1970. *Land and Social Change in East Nepal: A Study of Hindu-Tribal Relations*. London: Routledge & Kegan Paul.
- Caughley Ross Charles. 1982. *The Syntax and Morphology of the Verb in Chepang*. Pacific Linguistics, Series B, No. 84. Canberra: Research School of Pacific Studies.
- Caughley, Ross Charles. 2000. *Dictionary of Chepang: A Tibeto-Burman Language of Nepal*. Canberra: Pacific Linguistics.
- Corbett, Grenville. 1991. *Gender*. Cambridge: Cambridge University Press.
- Dahal, Subhadra Subba. 1999. 'Thami kinship terms', *Nepalese Linguistics*, 16: 9-12.
- Das, Sarat Chandra. 1902. *A Tibetan-English Dictionary with Sanskrit Synonyms* (revised and edited under the order of the Government of Bengal by Graham Sandberg and A. William Heyde). Calcutta: The Bengal Secretariat Book Depôt.

- Davids, Irene Maria Hendrina, and George van Driem. 1985. 'Limbu kinship terminology: A description', *Kailash*, XII (1-2): 115-156.
- DeLancey, Scott. 1989. 'Verb agreement in Proto-Tibeto-Burman', *Bulletin of the School of Oriental and African Studies*, LII (2): 315-333.
- Dobremez, Jean-François, Corneille Jest, Gérard Toffin, Marie-Christine Vartanian, and Françoise Vigny. 1974. *Carte écologique du Népal: région Kathmandu-Everest 1/250 000* (Cahiers népalais - documents no. 4). Paris: Centre National de la Recherche Scientifique.
- Doherty, Victor. 1974. 'The organizing principles of Brahmin-Chettri kinship', *Contributions to Nepalese Studies*, I (2): 25-41.
- van Driem, George. 1987. *A Grammar of Limbu*. West Berlin: Mouton de Gruyter.
- van Driem, George. 1990. 'An exploration of Proto-Kiranti verbal morphology', *Acta Linguistica Hafniensa*, 22: 27-48.
- van Driem, George. 1991a. 'Le proto-kiranti revisité, morphologie verbale du lohorung', *Acta Linguistica Hafniensa*, 24: 33-75.
- van Driem, George. 1991b. 'Bahing and the Proto-Kiranti verb', *Bulletin of the School of Oriental and African Studies*, LIV (2): 336-356.
- van Driem, George. 1992. 'In Quest of Mahākirāntī', *Contributions to Nepalese Studies: Journal of the Centre of Nepal and Asian Studies of Tribhuvan University*, XIX (2), 241-247.
- van Driem, George. 1993a. *A Grammar of Dumi*. Berlin: Mouton de Gruyter.
- van Driem, George. 1993b. 'The Newar verb in Tibeto-Burman perspective', *Acta Linguistica Hafniensa*, 26: 23-43.
- van Driem, George. 1993c. 'The Proto-Tibeto-Burman verbal agreement system', *Bulletin of the School of Oriental and African Studies*, LVI (2): 292-334.
- van Driem, George. 1995. *Een eerste grammaticale verkenning van het Bumthang: een taal van midden-Bhutan*. Leiden: Onderzoekschool CNWS.
- van Driem, George. 2001. *Languages of the Himalayas: An Ethnolinguistic Handbook of the Greater Himalayan Region, containing an Introduction to the Symbiotic Theory of Language* (2 Volumes). Leiden: Brill.
- van Driem, George. 2003. 'Mahakiranti revisited: Mahakiranti or Newaric?', pp. 21-26 in Tej Ratna Kansakar and Mark Turin, eds., *Themes in Himalayan Languages and Linguistics*. Kathmandu: South Asia Institute, Heidelberg and Tribhuvan University.
- van Driem, George. forthcoming. *A Grammar of Barām*.
- von Fürer-Haimendorf, Christoph. 1976. 'A nunnery in Nepal', *Kailash*, IV (2): 121-154.
- Gaborieau, Marc. 1978. *Le Népal et ses populations*. Paris: Presses Universitaires de France, Éditions Complexe.
- Gautam, Rajesh and Asoke K. Thapa-Magar. 1994. *Tribal Ethnography of Nepal* (2 vols.). Delhi: Book Faith India.

- Gellner, David N., Joanna Pfaff-Czarnecka and John Whelpton, eds. 1997. *Nationalism and Ethnicity in a Hindu Kingdom: The Politics of Culture in Contemporary Nepal*. Amsterdam: Harwood Academic Publishers.
- Genetti, Carol Elaine. 1994. *A Descriptive and Historical Account of the Dolakha Newari Dialect* (Monumenta Serindica 24). Tokyo: Institute for the Study of Languages and Cultures of Asia and Africa.
- Glover, Warren, Jessie R. Glover and Deu Bahadur Gurung. 1977. *Gurung-Nepali-English Dictionary, with English-Gurung and Nepali-Gurung Indexes*. Pacific Linguistics Series C, No. 51. Canberra: Australian National University.
- Goldstein, Melvyn C. ed. 2001. *The New Tibetan-English Dictionary of Modern Tibetan*. Berkeley: University of California Press.
- Grierson, George Abraham, ed. 1909. *Linguistic Survey of India (Vol. III, Part I, Tibeto-Burman Family: General Introduction, Specimens of the Tibetan Dialects, the Himalayan Dialects and the North Assam Group)*. Calcutta: Superintendent of Government Printing, India.
- Grierson, George Abraham, ed. 1927. *Linguistic Survey of India (Vol. I, Part I, Introductory)*. Calcutta: Superintendent of Government Printing, India.
- Grimes, Barbara F., ed. 1978. *Ethnologue*. 9th edition. Huntington Beach, California: Wycliffe Bible Translators.
- Grimes, Barbara F., ed. 1988. *Ethnologue: Languages of the World*. 11th edition. Dallas: Summer Institute of Linguistics.
- Grimes, Barbara F., ed. 1996. *Ethnologue: Languages of the World*. 13th edition. Dallas: Summer Institute of Linguistics.
- Haarh, Erik. 1968. *The Zhang-Zhung Language: A Grammar and Dictionary of the Unexplored Language of the Tibetan Bonpos* (Acta Jutlandica, Skrifter fra Aarhus Universitet, XL, 1). København: Einar Munksgaard.
- Hale, Austin and Shresthacarya Iswaranda. 1974. 'Is Newari a classifier language?', *Contributions to Nepalese Studies*, 1 (1): 1-21.
- Hanßon, Gerd. 1991. *The Rai of Eastern Nepal: Ethnic and Linguistic Grouping*. Kathmandu: Linguistic Survey of Nepal and Centre for Nepal and Asian Studies, Tribhuvan University.
- Hargrove, Mary. 1995. 'Joshua Project 2000 Step 3: Researching on Site and Preparing the Way for Church Planting', *Mission Frontiers*, XVII (11-12): 31-37.
- His Majesty's Government of Nepal. 1996. *Nepal Multiple Indicator Surveillance: Second Cycle, Primary Education*. Kathmandu: UNICEF and National Planning Commission Secretariat.
- His Majesty's Government of Nepal. 1999. *Statistical Year Book of Nepal*. Kathmandu: Central Bureau of Statistics and National Planning Commission Secretariat.

- His Majesty's Government of Nepal. 2003. *Statistical Year Book of Nepal*. Kathmandu: Central Bureau of Statistics and National Planning Commission Secretariat.
- His Majesty's Government of Nepal. vs 2031 (i.e. AD 1974-75). *Mecādekhi Mahākālī*. Kāthmāṇḍu, Nepāl: Śrī 5-ko Sarkār, Sañcār Mantrālaya, Sūcanā Vibhāg.
- Hocart, Arthur Maurice. 1937. 'Kinship systems', *Anthropos: Internationale Zeitschrift für Völker- und Sprachenkunde*, xxxii: 545-551.
- Hodgson, Brian Houghton. 1857. 'Comparative Vocabulary of the Languages of the broken Tribes of Népal' (inc. 'Comparative Vocabulary of the Kiranti Language'), *Journal of the Asiatic Society of Bengal*, xxvi: 317-522.
- Hodgson, Brian Houghton. 1880. *Miscellaneous Essays relating to India Subjects* (2 vols.). London: Trübner & Company.
- Höfer, Andrés. 1979. *The Caste Hierarchy and the State in Nepal, a Study of the Muluki Ain of 1854*. (Khumbu Himal. Ergebnisse des Forschungsunternehmens Nepal Himalaya, Band 13/2). Innsbruck: Universitätsverlag Wagner.
- Höfer, Andrés. 2000. 'Nomen est numen: notes on the verbal journey in some Western Tamang oral ritual texts', pp. 205-244 in Balthasar Bickel and Martin Gaenszle, eds., *Himalayan Space: Cultural Horizons and Practices*. Zürich: Völkerkundemuseum Zürich.
- Hutt, Michael and Abhi Subedi. 1999. *Nepali: A Complete Course in Understanding, Speaking and Writing*. London: Hodder & Stoughton.
- Hutt, Michael. 1997. *Modern Literary Nepali: An Introductory Reader*. Delhi: Oxford University Press.
- Informal Sector Service Centre (INSEC). 1995. *Human Rights Year Book 1994*. Kathmandu: INSEC.
- Integrated Community Development Movement. 1999. *Profile of the Village Development Committee of Alampu* [unpublished manuscript, 36 pages].
- Integrated Community Development Movement. 1999. *Profile of the Village Development Committee of Sundrawati* [unpublished manuscript, 41 pages].
- Jäschke, Heinrich August. 1990 and 1968 [1881]. *A Tibetan-English Dictionary with Special Reference to the Prevailing Dialects*. London: Routledge & Kegan Paul.
- Jørgensen, Hans. 1936. *A Dictionary of the Classical Newārī* (Det Kongelige Danske Videnskabernes Selskab, Historisk-filologiske Meddelelser, xxiii, 1). København: Einar Munksgaard.
- Jørgensen, Hans. 1941. *A Grammar of the Classical Newārī* (Det Kongelige Danske Videnskabernes Selskab, Historisk-filologiske Meddelelser, xxvii, 3). København: Einar Munksgaard.
- Kansakar, Tej Ratna [i.e. Tej Ratna Kansakār] and Mark Turin, eds. 2003. *Themes in Himalayan Languages and Linguistics*. Kathmandu: South Asia Institute, Heidelberg, and Tribhuvan University.

- Kansakar, Tej Ratna [i.e. Tej Ratna Kansakār]. 1993. 'The Tibeto-Burman languages of Nepal: A general survey', *Contributions to Nepalese Studies*, xx (2): 165-173.
- Karmay, Samten G. 1998. *The Arrow and the Spindle*. Kathmandu: Mandala Book Point.
- King, John Timothy. 1994. 'Picking up where Hodgson left off: Further notes on Dhimal', *Linguistics of the Tibeto-Burman Area*, xvii (2): 121-132.
- Kroeber, Alfred Louis. 1909. 'Classificatory systems of relationship', *Journal of the Royal Anthropological Institute of Great Britain and Ireland*, xxxix: 77-84.
- Kṣetrī, Dil Bahādur. no date. 'Thāmī Jātiko Mṛtyu-Sāskār: Sākṣipta Carca', *Jana�āti Mañc*, 1 (1): 20-22.
- Lall, Kesar [i.e. Keśar Lāl]. 1966. 'The Thami', *The Rising Nepal* (Friday, March 18, 1966), 1 (98): 3.
- LaPolla, Randy. 1992. 'On the dating and the nature of verb agreement in Tibeto-Burman', *Bulletin of the School of Oriental and African Studies*, lv (2): 293-315.
- Lass, Roger. 1984. *Phonology: An Introduction to Basic Concepts*. Cambridge: Cambridge University Press.
- Laver, John. 1994. *Principles of Phonetics*. Cambridge: Cambridge University Press.
- Lévi, Sylvain. 1905. *Le Népal, étude historique d'un royaume hindou* (Vols. I-III). Paris: Ernest Leroux.
- Lévi-Strauss, Claude. 1958. *Anthropologie Structurale*. Paris: Plon.
- Loeffen, 'Arno' Adriaan Isidorus Franciscus. 1995. *The Bhrámú Language of Central Nepal*. Leiden University: Unpublished Master's thesis (*doctoraalscriptie*).
- Majupuria, Indra and Trilok Chandra Majupuria. 1978. *Marriage Customs in Nepal [Ethnic Groups, their Marriage Customs and Traditions]*. Kathmandu: Indra Majupuria.
- Majupuria, Indra and Trilok Chandra Majupuria. 1980. *Peerless Nepal, Covering Broad Spectrum of the Nepalese Life in its Right Perspective*. Delhi: Smt. M. Devi.
- Malinowski, Bronisław. 1945. 'The problem of meaning in primitive languages', pp. 296-336 in C. K. Ogden and I. A. Richards, eds., *The Meaning of Meaning*. New York: Harcourt, Brace & Company.
- Malla, Kamal Prakash [i.e. Kamal Prakāś Malla], Tej Ratna Kansakar [i.e. Tej Ratna Kansakār], et al., eds. 2000. *A Dictionary of Classical Newari*. Kathmandu: Nepāl Bhāṣā Dictionary Committee, Cwasā Pāsā.
- Mānandhar, Rājendra. vs 2057 Pus 27 gate (i.e. Thursday, January 11, 2001). 'Dolakhāko Thāmīharū Āphūlāi 'Yatī' ko Santān Ṭhānchan', *Spacetime Daily*.

- Manandhar, Thakur Lal [i.e. Ṭhakur Lāl Mānandhar]. 1986. *Newari-English Dictionary: Modern Language of Kathmandu Valley*. New Delhi: École Française D'Extrême-Orient and Agam Kala Prakashan.
- Manzardo, Andrew E. 1982. 'Impression management and economic growth: The case of the Thakalis of Dhaulagiri zone', *Kailash*, IX (1): 45-60.
- Mapping Sub-Committee. 1988. *Index of Geographical Names of Nepal: Volume 2, Central Development Region*. Kathmandu: National Council for Science and Technology.
- Matisoff, James Alan. 1986. 'The languages and dialects of Tibeto-Burman: An alphabetic/genetic listing, with some prefatory remarks on ethnonymic and glossonymic complications', pp. 1-75 in John McCoy and Timothy Light, eds., *Contributions to Sino-Tibetan Studies*. Leiden: E.J. Brill.
- Matisoff, James Alan. 2000. 'On "Sino-Bodic" and other symptoms of neosubgroupitis', *Bulletin of the School of Oriental and African Studies*, LXIII (3): 356-369.
- Matisoff, James Alan. 2003. *Handbook of Proto-Tibeto-Burman: System and Philosophy of Sino-Tibetan Reconstruction*. Berkeley: University of California Press.
- Mazaudon, Martine. 1973. *Phonologie Tamang: Étude phonologique du dialecte tamang de Risiangku (langue tibéto-birmane du Népal)*. Paris: Société d'Études Linguistiques et Anthropologiques de France.
- McGregor, Roland S. 2002 [1993]. *The Oxford Hindi-English Dictionary*. Oxford: Oxford University Press.
- Michailovsky, Boyd. 1988. *La langue hayu* (Collection «Sciences du Language»). Paris: Éditions du Centre National de la Recherche Scientifique.
- Miller, Casper J. 1997 [1979]. *Faith-Healers in the Himalaya: An Investigation of Traditional Healers and their Festivals in the Dolakha District of Nepal*. Delhi: Book Faith India.
- National Committee for Development of Nationalities. no date. *National Committee for Development of Nationalities: An Introduction*. Kathmandu: His Majesty's Government, Ministry of Local Development.
- Nettle, Daniel and Suzanne Romaine. 2000. *Vanishing Voices: The Extinction of the World's Languages*. Oxford: Oxford University Press.
- Northey, William Brook, and Charles John Morris. 1928. *The Gurkhas, Their Manners, Customs and Country*. London: John Lane, the Bodley Head Ltd.
- Opgenort, Jean Robert Matheus Leonard. 2002. *The Wāmbule Language: Grammar, Lexicon, Texts and Cultural Survey of a Rai-Kiranti Tribe of Eastern Nepal*. Rijksuniversiteit te Leiden: Unpublished doctoral dissertation, 6 June 2002.
- Opgenort, Jean Robert Matheus Leonard. 2005. *A Grammar of Jero, With a Historical Comparative Study of the Kiranti Languages*. Brill's Tibetan Studies Library, Languages of the Greater Himalayan Region, 5/2. Leiden: Koninklijke Brill.

- Oppitz, Michael. 1982. 'Death and Kin Amongst the Northern Magar', *Kailash*, IX (4): 377-421.
- de Patoul, Philippe. 1998a. *Village Profile of Lāpilāñ VDC*. Dolakhā, Nepal: Practical Research Programme for Development.
- de Patoul, Philippe. 1998b. *A socio-anthropological study about development and modernisation among the Thami people of Nepal*. August 1998. [unpublished manuscript, 18 pages].
- Peet, Robert Creighton. 1978. *Migration, Culture and Community: A Case Study from Rural Nepal*. Columbia University: Unpublished doctoral dissertation.
- Pignède, Bernard. 1966. *Les Gurungs, une population himalayenne du Népal*. Paris/The Hague: Mouton & Co.
- Pokhrel, Bāl Kṛṣṇa, et al., eds. vs 2040 (i.e. AD 1983-84). *Nepālī Bṛhat Śabdakoś*. Kathmandu: Nepāl Rājakīya Prajñā-Pratiṣṭhān.
- Pommaret, Françoise. 1999. 'The Mon-pa revisited: In search of Mon', pp. 52-73 in Toni Huber, ed., *Sacred Spaces and Powerful Places in Tibetan Culture: A Collection of Essays*. Dharamsala: Library of Tibetan Works and Archives.
- Przyluski, Jean. 1924. 'les langues munda', pp. 385-403 in Antoine Meillet and Marcel Cohen, eds., *Les Langues du Monde*. Paris: Librairie Ancienne Édouard Champion.
- Rai, Hemlata. 2001. 'Janjatis want to stand up', *Nepali Times*, 11-17 May, 42: 4.
- Rai, Hemlata. 2002. 'Counting on Nepal', *Nepali Times*, 17-23 May, 94: 4-5.
- Rāī, Ṭaṅka Bahādur. vs 2041 (i.e. AD 1984-85). 'Thāmī Janjīvan - Choṭo Paricaya', *Pāruhāñ*, 4 (2): 1-4.
- Rāī, Uttar Kumār Cāmlīñ. 1997. 'Thāmī Khām', *Roduñ: Kirāt Bhāṣā Sārakṣaṇa Samiti*, November 1997, 1-3.
- Ramble, Charles Albert Edward. 1993. 'The Name Bhotey', *Himal*, VI (5): 17.
- Ramble, Charles Albert Edward. 1997. 'Se: Preliminary notes on the distribution of an ethnonym in Tibet and Nepal', pp. 485-513 in Samten Karmay and Philippe Sagant, eds., *Les habitants du toit du monde. Études recueillies en hommage à Alexander W. MacDonald*. Nanterre: Société d'Ethnologie.
- Ramble, Charles Albert Edward. 1998. 'The classification of territorial divinities in pagan and Buddhist rituals of South Mustang', pp. 123-143 in Anne-Marie Blondeau, ed., *Tibetan Mountain Deities, their Cults and Representations*. Veröffentlichungen zur Sozialanthropologie, Band 3. Wien: Verlag des Österreichischen Akademie der Wissenschaften.
- Rana, Greta, Christian Haberli and Gerard Neville. 1984. *Dolakha Trekking and Sight-Seeing off the Beaten Track*. Kathmandu: Integrated Hill Development Project.
- Rāñā, Śrīvīkram. vs 2049 Asār 12 gate (i.e. Friday, June 26, 1992). 'Thāmī Jāti: Sāskṛti ra Bhāṣā', *Sāptāhik Nepālī Āvāj*. Kāthmāñḍu, Nepāl.

- Regmi, Mahesh Chandra. 1976. *Landownership in Nepal*. Berkeley: University of California Press.
- Riccardi, Theodore, Jr. 1975. 'Sylvain Lévi: The history of Nepal. Part I', *Kailash*, III (3): 5-60.
- Romaine, Suzanne. 2000. *Language in Society: An Introduction to Sociolinguistics*. Oxford: Oxford University Press.
- Rutgers, Roland. 1998. *Yamphu: Grammar, Texts and Lexicon*. Leiden: Research School CNWS.
- Sāpkoṭā, Prem Prasād Śarmā. vs 2045 (i.e. AD 1988-89). *Dolakhāko Thāmī: Jāti tathā Sāskṛti - Ek Adhyayan*. Jhāpā, Nepāl.
- Scott, James. C. 1985. *Weapons of the Weak*. Yale: Yale University Press.
- Shafer, Robert. 1952. 'Newari and Sino-Tibetan', *Studia Linguistica, Revue de Linguistique Générale et Comparée*, 6: 92-109.
- Shafer, Robert. 1966. *Introduction to Sino-Tibetan, Part I*. Wiesbaden: Otto Harrassowitz.
- Shafer, Robert. 1974. *Introduction to Sino-Tibetan, Part IV*. Wiesbaden: Otto Harrassowitz.
- Shiwakoti, Ishwor Chandra [i.e. Īsvar Candra Śivakoṭī]. 1999. *A Study of Participation of Thami Community in Education in Suspa VDC Dolakha*. Department of Sociology, Tribhuvan University [unpublished research proposal, 4 pages].
- Shneiderman, Sara and Mark Turin. 2001. 'Preliminary etymological notes on Thangmi clan names and indigenous explanations of their provenance', *The Journal of Nepalese Literature, Art and Culture*, III (2): 69-83.
- Shneiderman, Sara and Mark Turin. 2003. 'Thangmi, Thami, Thani? Remembering a forgotten people', pp. 82-100 in Vasanta Thāmī, ed., *Niko Bacinṭe Smārikā*. Darjeeling: Indian Thami Welfare Association.
- Shneiderman, Sara. 2000. 'Sisterly clans: A collection of thoughts on Thami women', *Ādivāsī Mahilā Āvāj (Voice of Indigenous Women)*, II (3): 18-21.
- Shneiderman, Sara. 2002a. 'Embodied ancestors: Territory and the body in Thangmi funerary rites', pp. 233-252 in Katia Buffetrille and Hildegard Diemberger, eds., *Territory and Identity in Tibet and the Himalayas* (Brill's Tibetan Studies Library 2/9). Leiden: Brill.
- Slusser, Mary Shepherd. 1982. *Nepal Mandala: A Cultural History of the Kathmandu Valley*. Princeton: Princeton University Press.
- Smith, Grant. 1993. 'Placename persistence in Washington State', pp. 62-71 in Jesse Levitt, Leonard R. N. Ashley and Kenneth H. Rogers, eds., *Language in Contemporary Society: Proceedings of the International Conference on Geolinguistics*. New York: The American Society of Geolinguistics.
- Stein, Geneviève. 1972. 'Swadesh 100 Word List for Thami', p. 37-38 in Austin Hale, Anna Maria Hari and Burkhard Schöttelndreyer, eds., *Comp-arative*

- Vocabularies of Languages of Nepal*. Kirtipur: Summer Institute of Linguistics and Tribhuvan University.
- Stein, Rolf Alfred. 1959. *Les tribus anciennes des marches sino-tibétaines— légendes, classifications et histoire*. Paris: Imprimerie Nationale.
- Steinmann, Brigitte. 1996. 'Mountain deities, the invisible body of society', pp. 179-218 in Anne-Marie Blondeau and Ernst Steinkellner, eds., *Reflections of the Mountain: Essays on the History and Social Meaning of the Mountain Cult in Tibet and the Himalaya* (Veröffentlichungen zur Sozialanthropologie, Band 2). Wien: Verlag des Österreichischen Akademie der Wissenschaften.
- Stott, Colin. 1997. 'Introducing the Tailender Project: Telling 1000 more language groups about Jesus', *Sounds of Gospel Recordings*, August 1997, xx (8): 1-2.
- Subba, Tanka Bahadur [i.e. Ṭaṅka Bahādur Subbā]. 1993. 'Thami', pp. 184-188 in K. S. Singh, ed., *People of India: Sikkim* (Vol. XXXIX), Anthropological Survey of India. Calcutta: Seagull Books, India.
- Suspā Education Development Committee. no date, no name. Internal document, 5 pages.
- Tamot, Kashinath [i.e. Kāśināth Tamot]. 2002. 'Some characteristics of the Tibeto-Burman stock of Early Classical Newari', pp. 13-26 in Christopher I. Beckwith, ed., *Medieval Tibeto-Burman Languages*. Leiden: Brill.
- Thāmī, Buddhi Māyā and Prakāś Thāmī 'Dūśupere'. vs 2056 (i.e. AD 1999-2000). 'Thāmī Kabitā', p.42 in *Rāṣṭriya Bhāṣākā Kavita Saṅgālo*. Rāṣṭriya Janajāti Vikās Samiti: Kāthmāṇḍu, Nepāl.
- Thāmī, Megh Rāj Simī Riśmī. 1999. *Dolakhāreṇi*. Jhāpā, Nepāl.
- Toba Sueyoshi, and Ingrid Toba. 1997. *Preliminary Information for the KTM language Assessment Project: Thami* [unpublished report, 4 pages].
- Toba Sueyoshi. 1988. *Thami: A [Trans-Himalayan] Language of Nepal*. Central Department of English, Tribhuvan University [unpublished research proposal, 9 pages].
- Toba Sueyoshi. 1990. *Thami-English Dictionary* [unpublished manuscript, 87 pages].
- Tolsma, Gerard Jacobus. 1999. *A Grammar of Kulung*. Rijksuniversiteit te Leiden: Unpublished doctoral dissertation, 2 June 1999.
- Tripāthī, Sudhā and Rameś Khaḍkā. v.s. 2051 Vaiśākh (i.e. AD April-May 1994). *Dolakhā Darpaṇ*. Dolakhā: Dolakhā Sāhityik Samāj.
- Turin, Mark with Bir Bahadur 'Lile' Thami. 2004. *Nepali-Thami-English Dictionary*. Kathmandu: Martin Chautari.
- Turin, Mark. 1997. 'Too many stars and not enough sky: Language and ethnicity among the Thakali of Nepal', *Contributions to Nepalese Studies*, xxiv (2): 187-199.
- Turin, Mark. 1998a. 'The Thangmi verbal agreement system and the Kiranti connection', *Bulletin of the School of Oriental and African Studies*, LXI (3): 476-491.

- Turin, Mark. 1998b. 'Essentially a road to nowhere', *The Kathmandu Post* (Sunday, May 3, 1998), VI (73): 4.
- Turin, Mark. 1999a. 'Whence Thangmi? Historical ethnography and comparative morphology', pp. 451-477 in Yogendra Prasad Yadava and Warren G. Glover, eds., *Topics in Nepalese Linguistics*. Kathmandu: Royal Nepal Academy.
- Turin, Mark. 1999b. 'By way of incest and the golden deer: How the Thangmi came to be and the pitfalls of oral history', *Journal of Nepalese Studies*, III (1): 13-19.
- Turin, Mark. 2000a. 'Buildings, buildings, everywhere. But why?', *Face to Face: Magazine for Development*, 21: 28-29.
- Turin, Mark. 2000b. 'The changing face of language and linguistics in Nepal: Some thoughts on Thangmi', *Janaḷāti: Journal of Nationalities of Nepal*, II (1): 49-62.
- Turin, Mark. 2000c. 'Time for a true population census: The case of the miscounted Thangmi', *Nāgarik (Citizen)*, II (4): 14-19.
- Turin, Mark. 2000d. 'Shared words, shared history? The case of Thangmi and Late Classical Newar', *Newāh Vijñāna: The Journal of Newar Studies*, 3: 9-17.
- Turin, Mark. 2002a. 'Ethnonyms and other-nyms: Linguistic anthropology among the Thangmi of Nepal', pp. 253-269 in Katia Buffetrille and Hildegard Diemberger, eds., *Territory and Identity in Tibet and the Himalayas* (Brill's Tibetan Studies Library 2/9). Leiden: Brill.
- Turin, Mark. 2002b. 'Call me uncle: an outsider's experience of Nepali kinship', *Contributions to Nepalese Studies*, XXVIII (2), 277-283.
- Turin, Mark. 2003. 'Ethnobotanical notes on Thangmi plant names and their medicinal and ritual uses', *Contributions to Nepalese Studies*, XXX (1), 19-52.
- Turin, Mark. 2004. 'Thangmi kinship terminology in comparative perspective', pp. 101-139 in Anju Saxena, ed., *Himalayan Languages: Past and Present* (Trends in Linguistics, Studies and Monographs 149). Berlin and New York: Mouton.
- Turner, Ralph Lilley. 1997 [1931]. *A Comparative and Etymological Dictionary of the Nepali Language*. New Delhi: Allied Publishers Limited.
- Vajrācārya, Dhanavajra and Ṭek Bahādur Śreṣṭha. VS 2031 (i.e. AD 1974-75). *Dolakhāko Aitihāsik Ruprekhā*. Kāthmāṇḍu: Nepāl ra Eśiyālī Anusandān Sansthān, Tribhuvan Viśvavidyālaya.
- Vansittart, Eden. 1896. *Notes on Népal*. Calcutta: Office of the Superintendent, Government Printing, India.
- Vansittart, Eden. 1918. *Gurkhas: Handbooks for the Indian Army*. Calcutta: Office of the Superintendent, Government Printing, India. [revised by Nicolay, B.U.]
- Verhelst, Thierry. 1996. 'Cultural dynamics in development', *Network Cultures*, XXIV (4): 18.
- Vidyarthi, Lalita P. 1998. 'South Asian cultures', *The New Encyclopædia Britannica*. 15th edition, Volume 14. Chicago: Encyclopædia Britannica.

- Vinding, Michael. 1979. 'A preliminary report on kinship terminologies of the Bodish section of Sino-Tibetan speaking peoples', *Kailash*, VII (3-4): 191-225.
- Watters, David E. 2002. *A Grammar of Kham*. Cambridge: Cambridge University Press.

