



Universiteit
Leiden
The Netherlands

Monogenic models of migraine : from clinical phenotypes to pathophysiological mechanisms

Pelzer, N.

Citation

Pelzer, N. (2018, November 28). *Monogenic models of migraine : from clinical phenotypes to pathophysiological mechanisms*. Retrieved from <https://hdl.handle.net/1887/67103>

Version: Not Applicable (or Unknown)

License: [Licence agreement concerning inclusion of doctoral thesis in the Institutional Repository of the University of Leiden](#)

Downloaded from: <https://hdl.handle.net/1887/67103>

Note: To cite this publication please use the final published version (if applicable).

Cover Page



Universiteit Leiden



The handle <http://hdl.handle.net/1887/67103> holds various files of this Leiden University dissertation.

Author: Pelzer, N.

Title: Monogenic models of migraine : from clinical phenotypes to pathophysiological mechanisms

Issue Date: 2018-11-28



Chapter 4.

Recurrent coma and fever in familial hemiplegic migraine type 2.

A prospective 15-year follow-up of a large family with a novel

ATP1A2 mutation

N. Pelzer¹, D.E. Blom¹, A.H. Stam¹, L.S. Vijfhuizen², A.T.M. Hageman³, J.A. van Vliet⁴, M.D. Ferrari¹, A.M.J.M. van den Maagdenberg^{1,2}, J. Haan⁵, G.M. Terwindt¹

¹Department of Neurology, Leiden University Medical Center, Leiden, the Netherlands

²Department of Human Genetics, Leiden University Medical Center, Leiden, the Netherlands

³Department of Neurology, Rijnstate Hospital, Arnhem, the Netherlands

⁴Department of Neurology, Slingeland Hospital, Doetinchem, the Netherlands

⁵Department of Neurology, Alrijne Hospital, Leiderdorp, the Netherlands

Abstract

Background: Familial hemiplegic migraine (FHM) is a rare monogenic migraine subtype characterised by attacks associated with transient motor weakness. Clinical information is mainly based on reports of small families with only short follow-up. Here, we document a prospective 15-year follow-up of an extended family with FHM type 2.

Patients and methods: After diagnosing FHM in a patient with severe attacks associated with coma and fever, we identified eight more family members with FHM and one with possible FHM. All family members were prospectively followed for 15 years. In total 13 clinically affected and 21 clinically non-affected family members were genetically tested and repeatedly investigated.

Results: A novel p.Arg348Pro *ATP1A2* mutation was found in 14 family members: 12 with clinical FHM, one with psychomotor retardation and possible FHM, and one without FHM features. In 9/12 (75%) family members with genetically confirmed FHM, attacks were severe, long-lasting, and often associated with impaired consciousness and fever. Such attacks were frequently misdiagnosed and treated as viral meningitis or stroke. Epilepsy was reported in three family members with FHM and in the one with psychomotor retardation and possible FHM. Ataxia was not observed.

Conclusion: FHM should be considered in patients with recurrent coma and fever.

Introduction

Familial hemiplegic migraine (FHM) is a rare and clinically heterogeneous monogenic subtype of migraine with aura, characterised by attacks associated with transient motor weakness and various other neurological features.¹ Three causal genes have been identified: *CACNA1A* (FHM1), *ATP1A2* (FHM2) and *SCN1A* (FHM3).² *PRRT2* has been suggested as the fourth FHM gene but its association with hemiplegic migraine is complex and needs further investigation.³

Clinical recognition and diagnosis of hemiplegic migraine is complicated by its low prevalence and only limited phenotypic information mainly derived from cross-sectional case reports of mostly small families.⁴ Here we describe a 15-year clinical follow-up of an extended multigenerational FHM2 family with a novel *ATP1A2* mutation and a dramatic phenotype with severe attacks of hemiplegic migraine, impaired consciousness and fever.

Methods

After clinically diagnosing hemiplegic migraine in patient IV-41 (Figure 1), all available family members were interviewed and asked to complete an extensive headache questionnaire. The family members were prospectively followed from 1997 until 2012 (15 years) with in-person or telephone interviews conducted by research physicians or trained medical students with an average time interval of five years (Table 1). Additional clinical information and diagnostic test results (e.g. from computed tomography (CT) and magnetic resonance imaging (MRI), electroencephalography (EEG) and cerebrospinal fluid analysis (CSF)) were retrieved from clinical reports of visits to outpatient clinics and admissions to hospitals throughout the Netherlands. All migraine diagnoses were made according to standard criteria.¹

Because family member III-25 also developed severe restless legs syndrome (RLS) and RLS might be comorbid with migraine,⁵ all family members answered in 2012 a four-question telephone screener which was based on standard criteria for RLS.⁶ If the screener result was positive, RLS severity was assessed using the Dutch translation of a validated RLS rating scale questionnaire.

The study was approved by the Medical Ethics Committee of Leiden University Medical Center and all participants provided written informed consent.

For genetic analyses, DNA was extracted from peripheral leucocytes in venous blood according to standard protocols. Coding regions and adjacent intronic sequences of the three FHM genes

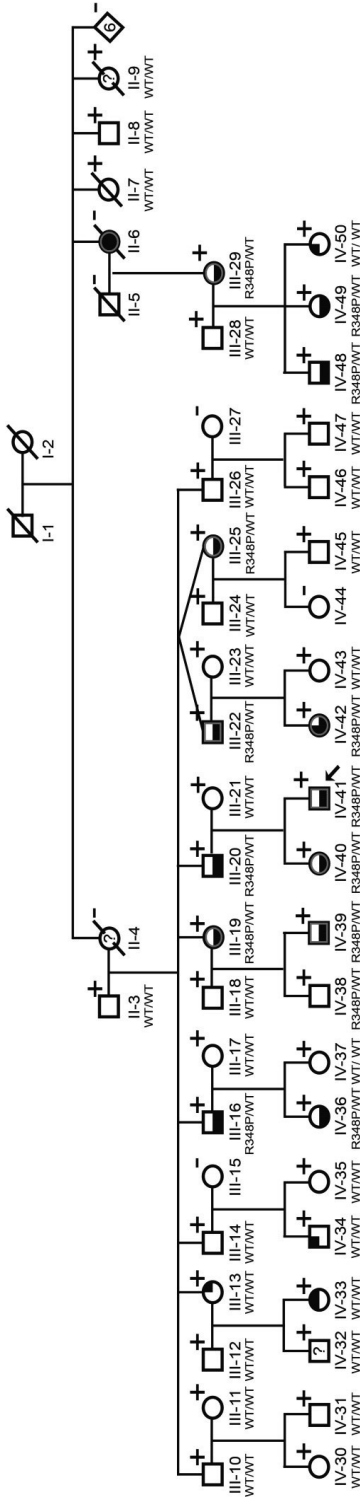

Figure 1. Pedigree of the family with familial hemiplegic migraine (FHM) type 2. Symbols: arrow: proband; black left upper square: Migraine without aura; black right upper square: Migraine with aura; black lower half: FHM. Inner grey symbol: episodes with coma/somnolence. Question marks indicate inconclusive phenotypes. Plus 'p' or minus '-' signs indicate the availability of a DNA sample for genetic analysis. R348P/WT indicates heterozygosity for the p.Arg348Pro A7P1A2 mutation; WT/WT indicates homozygosity for the wild-type allele. All mutation carriers suffer from hemiplegic migraine, except for IV-38 (aged 29 years at latest interview). The interview for subject IV-36 was complicated by psychomotor retardation, but she is shown as affected because she had severe attacks with hemiparalysis and epilepsy. For subject IV-44 no DNA sample was obtained.

(*CACNA1A*, *ATP1A2* and *SCN1A*) were initially sequenced using direct Sanger sequencing in genomic DNA of the father of the proband. After identification of the novel *ATP1A2* mutation c.1043G>C, p.Arg348Pro (Figure 2(b)) in 2010, DNA of all available family members was screened for the presence of this mutation.

Results

Included participants

In total 34 family members and nine spouses were interviewed and included in the analysis (pedigree in Figure 1). Family member IV-44 was interviewed but not genotyped. From family member II-6 we collected clinical information only from medical records as she already had died. Except for IV-49, all family members were interviewed on at least two occasions with average time intervals of five years (Table 1).

Genetic analysis

The *ATP1A2* mutation p.Arg348Pro (c.1043G>C) cosegregated with hemiplegic migraine in 12 out of 14 (86%) mutation carriers (not including affected obligate carrier II-6) and was absent in 28 relatives without hemiplegic migraine (including nine spouses) (Figure 1). The mutation was not present in various public databases (i.e. dbSNP (<http://www.ncbi.nlm.nih.gov/snp>); Ensembl (<http://www.ensembl.org/index.html>); Leiden Open Variation Database (LOVD) (http://chromium.lovd.nl/LOVD2/variants.php?action=search_unique&select_db=ATP1A2); Exome sequencing project (ESP) (6503 samples) (<http://evs.gs.washington.edu/EVS/>); Genome of the Netherlands (GoNL) (769 samples) (<http://www.nlgenome.nl/>); 1000Genomes (<http://browser.1000genomes.org>)). Amino acid Arg³⁴⁸ is located in the large intracellular loop between transmembrane domains M4 and M5 and is fully conserved between homologues and orthologues of human *ATP1A2* (Figure 2). In silico bioinformatics prediction programs all indicate mutation p.Arg348Pro as likely pathogenic: UMD predictor: pathogenic; SIFT: deleterious (score: 0); PolyPhen2: probably damaging (score: 1); Mutation Taster: disease causing (p value: 1).

Migraine attacks

Twelve out of 14 (86%) *ATP1A2* mutation carriers had unequivocal episodes of hemiplegic migraine usually associated with visual, sensory and dysphasic symptoms (Tables 1 and 2). Average age at onset was 9.8 years (range 6–18 years). Severe attacks were frequently triggered by (minor) head trauma. Aura duration ranged from 10 minutes to several days. Comorbidity of hemiplegic migraine

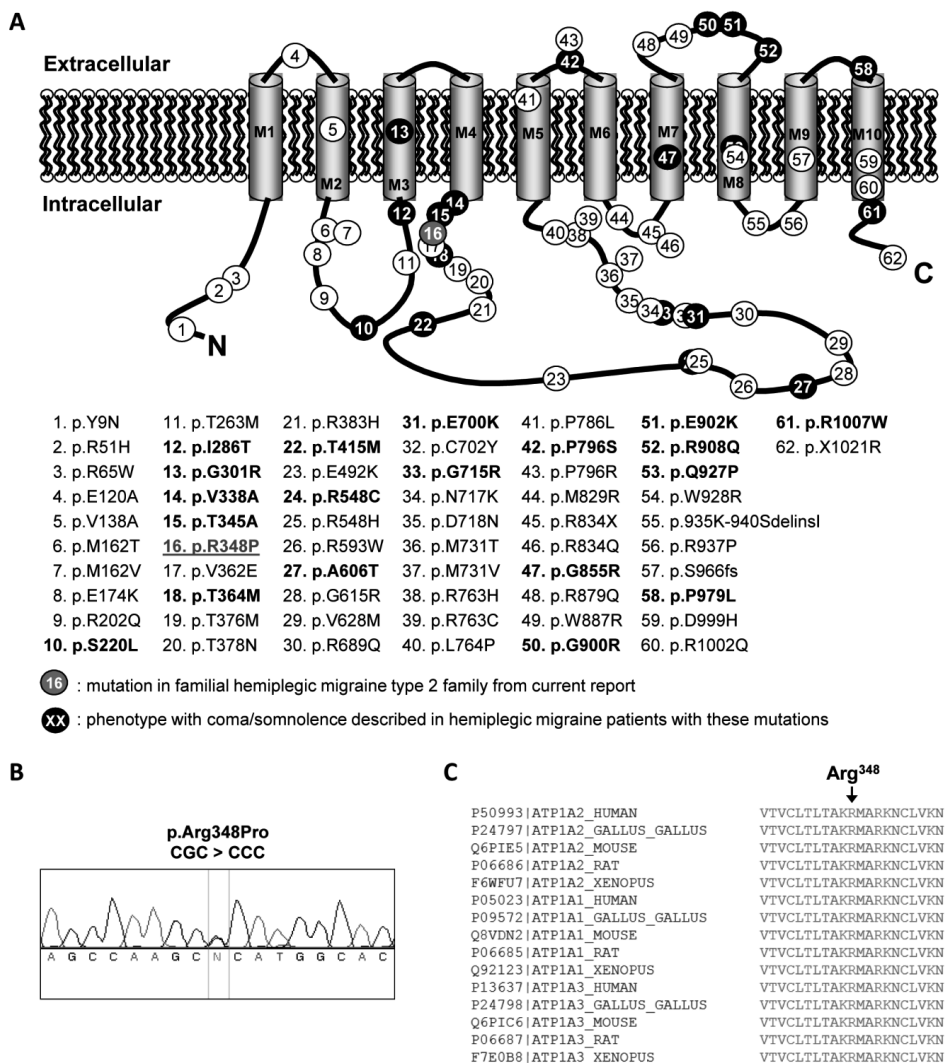

Figure 2. A. Schematic representation of reported sporadic and familial hemiplegic migraine mutations in the ATP1A2 protein. Mutations associated with a phenotype including features of coma and/or somnolence (black circles with white numbers) are spread throughout the ATP1A2 protein, albeit with some clustering in the area around the p.Arg348Pro mutation (grey circle with number 16) at the beginning of the large intracellular loop between domain M4 and M5. Figure redrawn from De Vries et al.² **B.** Electropherogram depicting the heterozygous c.1043G>C substitution. **C.** Alignment of the amino acid sequence of homologues and orthologues of human ATP1A2, showing full conservation of amino acid Arg³⁴⁸.

Table 1: Clinical follow-up of hemiplegic migraine (HM) attacks and associated symptoms in members of the family with Familial Hemiplegic Migraine type 2.

Family member	Age at onset	Aura symptoms* V S M D	Course of attacks onset - 1997-1999	Course of attacks previous contact - 2002	Course of attacks previous contact - 2007	Course of attacks previous contact - 2012
III-16	10	+ + + +	Age at interview: 47 years Attacks from age 10-18, no attacks since	Age at interview: 51 years No attacks	Age at interview: 56 years No clear HM attacks Around age 51: Diagnosed with 2 TIAs with hemianopia, aphasia, mouth asymmetry (attributed to smoking and paroxysmal atrial fibrillation)	Age at interview: 60 years Diagnosed with Transient Ischemic Attack at age 58 (hemianopia, dysphasia, mouth asymmetry) and 3x at age 60 1st: as previous, with scintillations, incoherent speech; 2nd: tingling and paresis of right arm, mouth asymmetry, aphasia; 3rd: left hemiparesis (30 min), confusion, fever, headache; diagnosed as delirium due to unknown infection)
III-19	13	+ + + +	Age at interview: 45 years HM attacks 2-3x per month. During pregnancy (age 35): viral meningitis with fever and coma (started with scintillations, headache, diarrhoea, vomiting), episode with left hemiparesis, vomiting, fever. Around giving birth: 2 episodes with hemiparesis, headache, vomiting, fever.		Age at interview: 54 years HM attacks 2-3x per month	Age at interview: 59 years HM attacks 1x per month on average At age 59: admitted to hospital with fever of unknown origin and dehydration following 3 HM attacks within 1 week
III-20	18	+ + + +	Age at interview: 44 years 10 HM attacks from age 18-26, no attacks since		Age at interview: 53 years Rarely HM attacks, attack-free for 5 years (last at age ± 48)	Age at interview: 58 years Attack-free for 2.5 years, before only rarely HM attacks, except for 3 attacks in 1 week at age 55 Age at interview: 56 years 2 HM attacks per year
III-22	8	+ + + +	Age at interview: 43 years 1 HM attack per 2 months At age 14: apparent epileptic seizure (rolling with his eyes, choking and gagging); At hospital admittance: somnolent, fever (39.2°C), recovered the next day		Age at interview: 52 years 2-3 HM attacks per year At age 51: headache, fever (39°C), confusion and agitation, unable to perform tasks, did not speak; full recovery over 9 days	Age at interview: 56 years On average 4 HM attacks per year At age 56: severe attack with aphasia, somnolence and hemiparesis; Suspected of brain infarction, received intravenous thrombolysis therapy, followed by coma and high fever; slow recovery with rehabilitation therapy
III-25	6	+ + + +	Age at interview: 43 years 9 HM attacks per year At age 6: after head trauma, comatose for 3 weeks, diagnosed with viral meningitis At age 40: comatose for 3 days, diagnosed with viral meningitis. Extensive rehabilitation therapy needed after both episodes		Age at interview: 52 years Attack frequency decreased during menopause At age 49: severe attack with somnolence, hemiparesis and aphasia, recovery within 2 days	Age at interview: 57 years 6-7 HM attacks per year
III-29	6	+ + + +	Age at interview: 43 years 1 HM attack per month At age 22: attack with hemiparesis and agitation, no decreased consciousness Around age 25: hospital admission during attack: comatose for several days		Age at interview: 52 years 1 HM attack per month	



Table 1 - continued: Clinical follow-up of hemiplegic migraine (HM) attacks and associated symptoms in members of the family with Familial Hemiplegic Migraine type 2.

Family member	Age at onset	Aura at symptoms* V S M D	Course of attacks onset - 1997-1999	Course of attacks previous contact - 2002	Course of attacks previous contact - 2007	Course of attacks previous contact - 2012
IV-36	?	? ? ? ?	unknown	Unknown	unknown	Unknown
IV-38	N.A.	- - - -			Age at interview: 25 years No symptoms suggestive of HM	Age at interview: 29 years No symptoms suggestive of HM
IV-39	13	+ + + +		Age at interview: 13 years Unconscious for 10 minutes after minor head trauma; diagnosed as severe concussion, 3 months later: 3 HM attacks in 1 week	Age at interview: 19 years Regular attacks, especially after minor head trauma (heading soccer balls) At age 15: severe episode: apathetic, drowsy, mild fever (38.3°C), followed by clonic seizures in arms and legs within a few days, rehabilitation therapy required to fully recover	Age at interview: 23 years Attack-free for 18 months, before that regular HM attacks
IV-40	9	- + + +	Age at interview: 13 years 3 HM attacks since age 9 At age 11: severe episode with headache, decreased consciousness; fever (38.6°C), hemiparesis with facial palsy, hemihypesthesia, hemianopia			Age at interview: 26 years 1 HM attack per 6 months to 1-2 HM attacks per month During pregnancy, 1-2x per month, afterwards attack-free for 18 months
IV-41	9	+ + + +	Age at interview: 11 years At age 9: severe attack after minor head trauma: headache, drowsy, nausea and vomiting followed by hemiparesis, hemihypesthesia and fever; consciousness decreased further; unable to perform simple tasks; nystagmus; after 2 weeks nearly recovered. Around severe episode: 2 episodes with confusion, automatisms and languidness		Age at interview: 20 years At age 13: severe attack requiring clinical rehabilitation therapy Attack-free for the following 7 years At age 20: episode with hemiparesis, incoherent speech and mild drowsiness after mild head trauma	
IV-42	11	+ + + +			Age at interview: 30 years At age 11: severe attack, sleepy and irritated, hemiparesis, dysarthria and dysphasia At hospital admission: somnolent; suspected of herpes encephalitis; recovery over a few days Around age 13: at a fair: scintillations, lost consciousness; bystanders observed muscle jerking: diagnosed with epilepsy Afterwards one attack at age 29, with scotoma, aphasia, paraesthesia and migraine headache, paresis unclear	Age at interview: 34 years Attack-free for 18 months, a few attacks per year in the 3 years before
IV-48	8	+ + + +	Age at interview: 19 years 2 attacks per year			
IV-49	7	+ + + +	Age at interview: 18 years Attack-free for 2 years		Age at interview: 29 years 1 attack per year	

* Aura symptoms: V: visual; S: sensory; M: motor; D: dysphasic; NA: not applicable. HM: hemiplegic migraine; TIA: transient ischaemic attack.

Table 2: Clinical characteristics of members of the family with Familial Hemiplegic Migraine type 2 with confirmed p.Arg348Pro ATP1A2 mutation.

Family member	General characteristics		Ictal symptoms							Permanent symptoms		Comorbidities	
	Gender	IHS HM criteria fulfilled	Attacks triggered by minor head trauma	Duration of aura	Fever	Coma / somnolence	Confusion	Seizures / epilepsy	Other brain stem symptoms	Mental retardation	Ataxia	Other migraine diagnosis	Other comorbidities
III-16	M	+	+	20–30 min	+	-	+	-	+	-	-	-	TIA: 5 times: 2x around age 51, 1x at age 58, 2x at age 60, paroxysmal atrial fibrillation, hypercholesterolemia
III-19	F	+	-	>60 min	+	+	-	-	+	-	-	typical aura without migraine headache	TTH, possibly medication-overuse headache
III-20	M	+	+	30–60 min	-	-	-	-	+	-	-	-	concussion (due to car accident), TTH
III-22	M	+	-	1–7 hours; 9 and 14 days	+	+	+	+	+	-	-	-	TTH
III-25	F	+	+	20 min–4 hours	+	+	-	-	+	-	-	-	TTH, gout, restless legs syndrome, varicose veins in legs
III-29	F	+	-	45–60 min	?	+	?	-	+	-	-	-	-
IV-36	F	?	-	-	-	-	-	+	-	+	-	-	microcephaly / lissencephaly, retinal dysplasia, subtotal retinal ablation in right eye
IV-38	M	-	N.A.	N.A.	-	-	-	-	-	-	-	-	-
IV-39	M	+	+	10–20 min	+	+	-	+	-	-	-	-	-
IV-40	F	+	-	?	+	+	-	-	+	-	-	-	-
IV-41	M	+	+	minutes–2 weeks	+	+	+	-	+	-	-	-	-
IV-42	F	+	-	2 hours	?	+	+	+	+	-	MO	-	-
IV-48	M	+	-	15–45 min	?	?	?	?	+	-	-	-	intracerebral haemorrhage at birth (due to vacuum extraction), deaf in left ear
IV-49	F	+	-	60 min–48 hours	?	?	?	?	+	-	-	-	concussion at age 18 months

M: male; F: female; MO: migraine without aura; TTH: tension-type headache; NA: not applicable; IHS: International Headache Society; HM: hemiplegic migraine.

with other migraine subtypes was rare. Only subject IV-42 also had migraine without aura and subject III-19 had typical migraine auras without headache. Symptoms suspect of brainstem auras were often reported. Nine mutation carriers had severe attacks with impaired consciousness (i.e. somnolence or coma) and confusion, which are further discussed below. All 12 mutation carriers with hemiplegic migraine also reported other brainstem symptoms such as dysarthria, diplopia or vertigo. Bilateral sensory or motor auras, either switching to the contralateral side or spreading to both sides during attacks, were reported by five mutation carriers. Cerebellar ataxia or atrophy was not found.

Subject IV-38 had never experienced migraine or other paroxysmal neurological symptoms at the time of the last interview (at age 29 years). Diagnosing whether subject IV-36 suffered from hemiplegic migraine was difficult due to severe psychomotor retardation and comorbid epilepsy. She was suspected of a lissencephaly, was wheelchair-dependent and suffered from clonic seizures with nausea and vomiting followed by hemiplegia for at least 20 minutes. These attacks appeared to be followed by headache over several days. Walking was often (increasingly) impaired for a week after such an attack.

Subject II-6 died before the study started and is an obligate *ATP1A2* mutation carrier. She had several paroxysmal focal neurological symptoms during pregnancy that were (wrongly) diagnosed as transient ischaemic attacks. At age 61 she had an episode with hemiparesis and coma, with restlessness, sub-febrile temperature, and vomiting. Four years later she again developed a hemiparesis, with vertigo, yawning and dysphagia. Around age 67 to 68 she had several attacks with confusion, vomiting and hemiparesis according to her medical files.

Confusion, somnolence and coma

Nine out of 12 *ATP1A2* mutation carriers with hemiplegic migraine experienced severe episodes with confusion, somnolence, or coma. These attacks often lasted days to weeks. Results from diagnostic procedures during these episodes are presented in Table 3. Abnormalities on ictal routine brain CT and/or MRI were found only in subjects IV-39 (Figure 3) and IV-41 (data not shown), in whom asymmetric congestion/ hyperaemia or swelling was seen in one hemisphere. Single-photon emission computerised tomography (SPECT) showed symmetric and asymmetric areas of hypoperfusion in subjects IV-40 and IV-41 (data not shown).

Table 3: Diagnostic procedures performed during or in between hemiplegic migraine (HM) attacks in members of the family with Familial Hemiplegic Migraine type 2.

Family member	CSF analysis	Temporal relation to HM attack	EEG	Temporal relation to HM attack	CT	Temporal relation to HM attack	MRI	Temporal relation to HM attack
III-16	Pleocytosis (L 90/3; 16% mononuclear, 84% polynuclear) No microorganisms or viruses detected	At age 60: 1 day after onset of attack with hemiparesis, confusion and fever	Asymmetric pattern with slow-waves (delta and theta); No epileptiform abnormalities	At age 60: 1 day after onset of attack with hemiparesis, confusion and fever	No abnormalities	At age 60: 2 days after onset of attack with hemiparesis, confusion and fever	No abnormalities; no ischemia, no diffusion changes	
III-19	Pleocytosis (L 400/3; differentiation unavailable) IgG herpes simplex positive (also in blood)	At age 35: attack with scintillations, headache, vomiting, diarrhoea, high fever and coma	Alpha-dominant EEG; theta-waves on both sides; Slight focal irritative abnormalities in fronto-temporal region (left>right)	At age 44: in between attacks	No abnormalities	At age 35 & age 44: possible relation to HM attacks unknown	-	-
III-20	-	-	-	-	-	-	-	-
III-22	1) No pleocytosis (L 4/3) 2) Pleocytosis (L 37/3) No microorganisms or viruses detected	1) At age 14: after apparent epileptic seizure with fever and somnolence 2) At age 51: during attack with headache, fever, confusion, agitation	1) Slight asymmetry; abnormalities in right hemisphere, no epileptiform abnormalities 2) Slow activity on left side; after a few days: less asymmetry, but flattened with some epileptic activity	1) At age 14: after apparent epileptic seizure with fever and somnolence 2) At age 51: during attack with headache, fever, confusion, agitation	Many artefacts due to movements, no clear abnormalities	At age 51: during attack with headache, fever, confusion, agitation	No abnormalities	At age 42: in between attacks
III-25	No pleocytosis No microorganisms or viruses detected	At age 56: during attack with right hemiparesis, fever and coma	Marked asymmetry with abnormalities over left hemisphere (and some over right hemisphere)	At age 56: during attack with right hemiparesis, fever and coma	1) No abnormalities 2) CT and CTA no abnormalities	1) At age 49: during attack with somnolence 2) At age 56: during attack with right hemiparesis, high fever and coma	Artefacts due to movements, but no clear abnormalities, except for dural enhancement (shortly after lumbar puncture)	At age 56: during attack with right hemiparesis, fever and coma
III-29	No abnormalities	At age 22: during attack with left hemiparesis, fever and restlessness	Severe diffuse functional abnormalities over right hemisphere	At age 22: during attack with left hemiparesis, fever and restlessness	No abnormalities	At age 36: in between attacks	-	-
IV-36	-	-	Epileptiform abnormalities reported and slight focal irritative abnormalities in frontotemporal region	Possible relation to HM attacks unknown	Supratentorial cortical and central atrophy with ventriculomegaly, cerebellar cortical atrophy	At age 16: possible relation to HM attacks unknown	Pachygyria, abnormal myelination of brain stem and internal capsule; lissencephaly?	At age 18: possible relation to HM attacks unknown
IV-38	-	-	-	-	-	-	-	-

Table 3 - continued: Diagnostic procedures performed during or in between hemiplegic migraine (HM) attacks in members of the family with Familial Hemiplegic Migraine type 2.

Family member	CSF analysis	Temporal relation to HM attack	EEG	Temporal relation to HM attack	CT	Temporal relation to HM attack	MRI	Temporal relation to HM attack
IV-39	No pleocytosis (L 9/3) PCR herpes simplex negative	At age 15: during attack with headache, somnolence and fever	Asymmetric severe slowing (mostly the left side) No epileptiform abnormalities	At age 15: During attack with headache, somnolence and fever, clonic attack lasting 5 minutes	No abnormalities	At age 15: during attack with headache, somnolence and fever	Diffuse swelling of the left hemisphere (most temporal region), see also Figure 3	At age 15: during attack with headache, somnolence and fever
IV-40	No pleocytosis	At age 11: during attack with hemiparesis, headache, somnolence and fever	-	-	CT scan: no abnormalities SPECT scan: symmetrical hypoperfusion of both cerebellar hemispheres and basal ganglia, and defects in left frontal, temporal and parieto-occipital regions	At age 11: during attack with hemiparesis, headache, somnolence and fever	-	-
IV-41	Pleocytosis	At age 9: during attack with hemiparesis, headache, somnolence and fever	Diffuse hypofunction without epileptic features, after 11 days residual hypofunction on left side, clear overall improvement	At age 9: during attack with hemiparesis, headache, somnolence and fever, and 11 days later	SPECT scan: reduced perfusion of the left hemisphere	At age 9: during attack with hemiparesis, headache, somnolence and fever	Congestion/ hyperaemia of the left hemisphere, except for the frontal region	At age 9: during attack with hemiparesis, headache, somnolence and fever
IV-42	No abnormalities	At age 11: during episode with headache, right hemihypoesthesia hemiparesis, dysarthria, incoherent speech, vomiting and somnolence	Many abnormalities, predominantly in the left hemisphere After 7 days: abnormalities predominantly in the posterior areas, right more than left, strong asymmetry	At age 11: 3 and 7 days after admission for episode with headache, right hemihypoesthesia hemiparesis, dysarthria, incoherent speech, vomiting and somnolence	No abnormalities	At age 11: during episode with headache, right hemihypoesthesia hemiparesis, dysarthria, incoherent speech, vomiting and somnolence	-	-
IV-48	-	-	-	-	-	-	-	-
IV-49	-	-	-	-	-	-	-	-

HM: hemiplegic migraine; CSF: cerebrospinal fluid; CT: computed tomography; CTA: computed tomography angiography; SPECT: single-photon emission computerised tomography; Ig: immunoglobulin; PCR: polymerase chain reaction; MRI: magnetic resonance imaging; EEG: electroencephalogram.

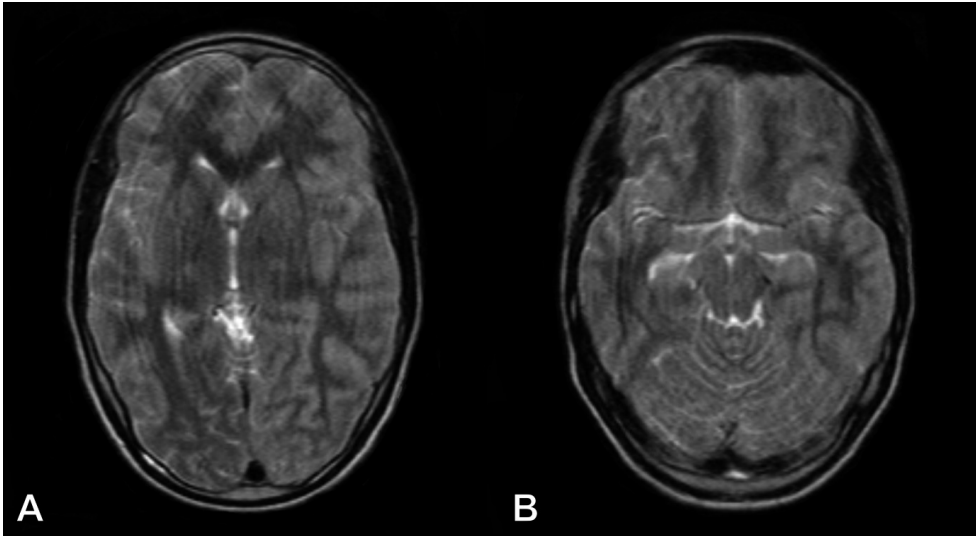

Figure 3. Brain MRI performed during attack with somnolence and fever. Axial T2-weighted brain MRI of subject IV-39 at age 15 showing diffuse swelling of the left hemisphere (A), most evident in the left temporal region (B), with a slight rightward midline shift. Some artefacts occurred due to movements of the patient during the MRI scan. MRI: magnetic resonance imaging.

Fever up to $>39^{\circ}\text{C}$ was reported in seven *ATP1A2* mutation carriers during severe episodes with confusion, somnolence or coma. These episodes were often suspected of viral meningo-encephalitis and treated as such. Of the nine *ATP1A2* mutation carriers with severe episodes, CSF analyses were available for 10 separate episodes which revealed pleocytosis on four occasions. Viral and bacteriological tests were negative, except for one episode in subject III-19, in whom immunoglobulin (Ig)G for herpes simplex virus was reported positive in CSF and blood (polymerase chain reaction (PCR) was not yet available at the time) in combination with a high pleocytosis of 400/3 leucocytes (differentiation unavailable). She recovered spontaneously without antiviral treatment, which was not prescribed as she was pregnant at the time. CSF protein levels were within normal ranges on all occasions. A slight blood leucocytosis was observed in two patients, but C-reactive protein (CRP) levels were normal in all cases and other causes of infection were not identified during any of the severe episodes.

Epilepsy

The family members with hemiplegic migraine often described their attacks as ‘seizures’ rather than migraine but only four mutation carriers were ever diagnosed with epilepsy. EEG results are presented in Table 3. Subject IV-36 had focal epilepsy with secondary generalisation. Epileptic

activity was detected on EEG at age 11, and follow-up interictal EEGs showed bilateral irritative activity, mainly in the frontotemporal regions. Subject III-22 seemingly had a seizure at age 14, when he started to 'roll with his eyes' and choked and gagged, but epileptiform abnormalities were not detected on repeated EEGs shortly after this attack. At age 51 he had an attack with headache, fever, confusion and agitation, and an ictal EEG initially showed only asymmetric slowing but when repeated after a few days 'some epileptic activity' was noted. Subject IV-39 had a single clonic seizure shortly after an attack of hemiplegia, with asymmetric severe slowing but no epileptiform abnormalities on EEG. Subject IV-42 had an apparent episode of photosensitive epilepsy around age 13 and was treated with sodium valproate for the following eight years, but epileptiform abnormalities on EEG were never reported. Non-epileptiform and (often) asymmetric EEG abnormalities with slow activity in one hemisphere were reported in eight out of 12 *ATP1A2* mutation carriers with hemiplegic migraine.

Treatment

Over time, various prophylactics were used by the *ATP1A2* mutation carriers with hemiplegic migraine attacks, including sodium valproate, topiramate, lamotrigine, metoprolol and phenytoin. Efficacy of prophylactic or acute treatment was not systematically reported. Medication use could not be clearly linked to reduced attack frequency, as attack frequencies were generally low. Sumatriptan was reported to have a beneficial acute effect on headache and was (retrospectively wrongly) supposed to have a beneficial effect on focal neurological symptoms during a prolonged attack in two patients (IV-40 and IV-41). Antiviral treatment (acyclovir) or antibiotics were often prescribed during attacks with coma and fever. Treatment with haloperidol did not improve symptoms of confusion (suspect of delirium) during an attack in subject III-22. Of note, subject III-25 was first suspected of cerebral infarction during a severe attack, and received intravenous thrombolysis, after which she deteriorated quickly and became comatose. She subsequently developed a high fever and was treated with antibiotics and antiviral medication. Her EEG showed marked asymmetric slowing of background activity over the left hemisphere, but MRI and CSF were normal (data not shown). She recovered slowly but fully.

Clinical course over a 15-year follow-up

The average attack frequency was consistently low, with no more than a few attacks per year (Table 1). Only two patients reported a higher attack frequency of once per month or more, but most had attack-free intervals of several years. Of note, three patients reported spontaneous exacerbations with up to three attacks a week. Several younger patients had experienced only one severe episode

with somnolence, coma and/or confusion, but recurrent severe episodes were observed during follow-up in older patients (Tables 1 and 2). One subject (III-31) suffered from at least four episodes with coma. Three patients required rehabilitation therapy after attacks but eventually regained all motor skills. Several patients reported some remaining cognitive complaints after severe episodes, which had, however, not been tested formally. Overall, severe attacks were reported to occur during the entire lifespan from age 6 to 60 years. Remarkably, some patients could not accurately remember their childhood or teenage attacks which they had, however, clearly described during previous contact moments.

Clinical phenotype of relatives without *ATP1A2* mutation

None of the family members without the p.Arg348Pro *ATP1A2* mutation suffered from hemiplegic migraine, but some did have other migraine subtypes (Figure 1). Three (IV-33, IV-34 and IV-50) were diagnosed with migraine without aura, subject IV-33 had several attacks of probable migraine with aura and subject III-13 had a maximum of five migraine with aura attacks around age 20. Two subjects had non-motor auras without (migrainous) headache: isolated possible visual auras two to three times per year in IV-32 and visual and sensory auras two to three times per year in IV-37. DNA of subject IV-44 was not available, but she never had migraine symptoms. Like her mother (III- 25), she also suffered from RLS. The *ATP1A2* mutation was absent in all nine investigated spouses and none had migraine symptoms. Spouse III-17 also suffered from RLS.

Discussion

We describe a unique 15-year follow-up of a large FHM family with a novel p.Arg348Pro *ATP1A2* mutation. To our knowledge, this is the largest FHM2 family with such a long prospective follow-up described to date. The long-term follow-up allowed us to observe that severe attacks with long-lasting auras and impaired consciousness, often accompanied by fever, recurred several times in the same individual, and also that none of the mutation carriers showed permanent impairments. The high prevalence of severe attacks and their recurrence in mutation carriers indicates that these are part of the FHM2 spectrum, especially since most severe attacks also included typical hemiplegic migraine aura symptoms. Importantly, some patients had only severe attacks associated with impaired consciousness and fever increasing the risk of misdiagnosis (e.g. viral meningitis). Indeed, many were not recognised as FHM patients during numerous hospital admissions. One subject was even treated with intravenous thrombolysis for suspected cerebral infarction and several patients were prescribed anti-platelet aggregating drugs because of suspected transient ischaemic attacks. Notably, several patients in this family did not consider themselves migraine patients but rather

patients with transient ischaemic attacks or epilepsy. While this is not a unique feature of this family, it likely made an important contribution to the many misdiagnoses. This perception was reinforced by the relatively rare comorbidity of hemiplegic migraine with other migraine subtypes, which is in contrast to previous studies.⁷ However, these studies mostly included patients with clinically but not genetically confirmed hemiplegic migraine and may thus concern different genetic and clinical subtypes.

Both the strong conservation of the affected amino acid that is located in an important functional domain of *ATP1A2* with many FHM2 mutations and in silico predictions strongly point towards pathogenicity of the p.Arg348Pro *ATP1A2* mutation. Moreover, the mutation co-segregated with hemiplegic migraine in all 12 FHM family members. In two additional mutation carriers, hemiplegic migraine could not be unequivocally confirmed. Due to psychomotor retardation, the attacks of subject IV-36 could not be reliably differentiated from (a combination with) epilepsy (although the combination of hemiplegia, headache, nausea, and vomiting strongly suggested hemiplegic migraine). Mutation carrier IV-38 was clinically unaffected and thus could be a non-penetrant case which is not uncommon in FHM.^{8,9} However, because of his relatively young age (29 years old) at the time of the last interview, he still could develop hemiplegic migraine when growing older.

In literature, severe episodes with somnolence or coma have been described previously in hemiplegic migraine patients with an *ATP1A2* mutation. Table 4 provides a review of the clinical characteristics of these FHM2 families and sporadic hemiplegic migraine patients.^{8,10-24} *ATP1A2* mutations that are associated with an FHM phenotype that includes impaired consciousness are spread out over most of the *ATP1A2* protein (Figure 2). Although some clustering of mutations with such associated symptoms occurs around the position of Arg³⁴⁸, which is the location of the mutation in our FHM2 family, these phenotypes cannot for sure be linked to mutations in a specific area of *ATP1A2*.

Coma has also been described in FHM1 patients, in particular in patients with the p.Ser218Leu *CACNA1A* mutation.²⁵⁻²⁷ In FHM1, ictal coma has been associated with cytotoxic cerebral oedema, possibly caused by traumatic depolarisation after brain injury, when increased ionic perturbations due to the calcium channelopathy may cause cellular swelling.^{25,28} In our FHM2 family ictal brain MRIs are available for only a few family members, revealing unilateral diffuse swelling in two patients.

Table 4: Characteristics of patients previously described in literature with hemiplegic migraine type 2 with episodes including somnolence or coma.

Publication	ATP1A2 mutation	Proportion of patients with impaired consciousness	Impaired consciousness defined as	Age at onset HM attack with impaired consciousness	Number of HM attacks with impaired consciousness	Maximum duration of HM attack with impaired consciousness	Additional ictal symptoms	Additional features / permanent symptoms
Echenne, Neuroepidiatr 1999. ¹⁰	linkage to #1q21-23	1/1	drowsiness, followed by coma	5 years	7 (41 per year)	3-5 days	confusion, irritable and aggressive behaviour; epileptic seizures (not with every attack)	typical migraine without aura, of brief duration
Jurkat-Rott, Neurol 2004. ⁸	P979L	1/5	coma	3 years	Recurrent	1-12 days	unknown	mental retardation (determined at age 4), seizures
Spadaro, Neurogen 2004. ¹¹	E902K	1/1	coma	0.7 years	Unknown	20 days	confusion, fever, cortical oedema on MRI	unknown
	G301R	6/8	coma, drowsiness, torpor	8/9 years	4 in 8 years	5-7 days of coma, 25 days of hemiparesis and global aphasia	tonic-clonic seizure (in 5/6 patients), fever, sensory deficit and cerebellar signs (horizontal nystagmus, dysarthria, dysmetria, gait ataxia, and intentional tremor), psychomotor agitation with incoherent speech, diffuse oedema on one occasion	unknown
Kaunisto, Neurogen 2004. ¹²	T345A	4/11	coma	unknown (5-31 years at 1st HM attack)	Unknown	2 days-2 weeks coma	fever	coma triggered by mild head trauma (in 4/11 patients)
Pierelli, Cephalalgia 2006. ¹³	E700K	1/3	drowsiness, coma	40 years (10 years at 1st migraine attack)	several attacks with drowsiness, one attack with coma	3 days coma	confusion, cerebral angiography followed by HM attack with coma	
Jen, J Neurol Neurosurg Psychiatry 2007. ¹⁴	A606T (de novo)	1/1	somnolence	7 years	Unknown	7 days (hemiplegia resolved over several weeks)	confusion, generalised tonic-clonic seizure (6 days after onset of hemiplegia)	more typical hemiplegic migraine, often induced by minor head trauma
Vannolkot, Eur J Hum Genet 2007. ¹⁵	I286T T415M	1/2	drowsiness	unknown (8 years at 1st HM attack)	Unknown	9 days	visual auras, dysphasia, disorientation, confusion, hyperaemia of left hemisphere on MRI and high voltage slow activity over left hemisphere on EEG during severe attack at age 20	attacks sometimes triggered by mild head injury
Castro, Clinical Genetics 2008. ¹⁶	P796S	2/3	impaired/ lowered level of consciousness, somnolence	7 years 4 years	Unknown	unknown	fever, severe learning difficulties, fixed look, hypotonic limbs and then somnolence, agitation and confusion, possible cortical oedema on MRI	mild mental retardation (IQ of 53), insomnia, dystonic posturing when eating with dominant hand
	G900R	4/9	drowsiness, followed by coma, somnolence evolving into stupor	29 years 22 years	Unknown	a few days to a few weeks	high fever and meningism, generalised tonic-clonic status epilepticus (in 3/9 patients)	3 seizures (secondary generalised tonic-clonic) in 1 year following HM attack with coma, migraine without aura (since adolescence), recurrent right-sided partial motor seizures

Table 4— continued: Characteristics of patients previously described in literature with hemiplegic migraine type 2 with episodes including somnolence or coma.

Publication	ATP1A2 mutation	Proportion of mutation carriers with impaired consciousness	Impaired consciousness defined as	Age at onset HM attack with impaired consciousness	Number of HM attacks with impaired consciousness	Maximum duration of HM attack with impaired consciousness	Additional ictal symptoms	Additional features / permanent symptoms
Lebas, Cephalalgia 2008. ³⁸	R548C	1/4	agitated coma	12 years (4 years at 1st migraine attack)	Unknown	7 days	confusion, fever	generalised tonic-clonic seizures since age 5, absence seizures since age 6
De Vries, Epilepsia 2009. ¹⁹	G855R	1/3	rapidly progressive drowsiness	unknown (5 years at 1st headache attack)	Unknown	unknown	ataxia	(febrile) epileptic seizures (from 9 months until age 5), behavioural problems, mild learning difficulties
Riant, Neurology 2010. ²⁰	V338A	1/1	coma	unknown (3 years at onset HM)	Unknown	unknown	unknown	mild cognitive delay
	Q927P	1/2	coma	unknown (9 years at onset HM)	Unknown	unknown	unknown	generalised epileptic seizures
De Sanctis, Headache 2011. ²¹	G715R	1/1	somnolence	6 years	Unknown	24 hours full recovery in 4 weeks	fever, aphasia, right facial nerve impairment, flaccid right hemiplegia with hyperreflexia, ipsilateral positive Babinski sign and diminished pain, and touch sensitivity on the right side brain oedema on 10th day, complete normalization after 2 months	unknown
Toldo, Cephalalgia 2011. ²²	T364M	1/1	lethargy drowsiness	8 years (2 years at onset HM)	Unknown	hemiplegia resolved after 1 month, global aphasia after 40 days	fever, global aphasia, right-central facial nerve palsy and sphincter incontinence mild swelling of cortical sulci on 2nd MRI (day 4)	2 episodes of febrile convulsions at age 11 months
Pisano, Cephalalgia, 2013. ²³	R1007W	1/7	impaired consciousness	12 years	Unknown	24 hours	brain oedema in left-centrotemporal region on MRI performed 4 days after attack	myoclonic seizures during drowsiness (at age 18 months) migraine without aura (from age 6)
	S220L	1/4	coma	(20 years at onset HM)	1 HM attack with coma	unknown	confusion, aphasia	delayed physical development and language impairment
Roth, Cephalalgia, 2014. ²⁴	R908Q	2/3	coma	(9–10 years at onset HM)	3–4 HM attacks with coma	several weeks	confusion, aphasia, generalised epileptic seizure	also migraine attacks without hemiparesis

HM: hemiplegic migraine; MRI: magnetic resonance imaging; IQ: intelligence quotient; EEG: electroencephalogram.

Besides a possible role for cerebral oedema, decreased consciousness in our family may have been due to spreading depression within the brainstem. In FHM1 and FHM2 transgenic mouse models, the triggering threshold for cortical spreading depression – the likely underlying mechanism for migraine aura – was decreased.²⁹⁻³¹ In transgenic mouse models harbouring the p.Ser218Leu *CACNA1A* mutation, cortical spreading depression propagated into subcortical areas, basal ganglia and diencephalon and vice versa could also start in the deeper brain regions and propagate upwards.^{29,32} Profound subcortical spreading depression may thus explain decreased consciousness in FHM1, and conceivably also in FHM2, possibly in combination with (secondary) oedema.

Several other FHM2 families have been described with more than one patient with severe attacks associated with impaired consciousness, suggesting a true rather than coincidental association with *ATP1A2* mutations.^{11,12,16,17,20,24} In many of these families, however, unlike in our family, comorbid generalised epileptic seizures were common.^{11,17,20,24} Differentiating epilepsy from hemiplegic migraine can be difficult as migraine motor auras may resemble postictal paresis and decreased consciousness is often seen after generalised epileptic seizures.³³ However, if the paresis evolved gradually over minutes, as is typical for motor auras in migraine, these entities can be differentiated. Moreover, fever is also sometimes seen in the post-epileptic state.³⁴ Although EEGs were frequently performed in our family, abnormalities possibly suggesting epilepsy were found in only one patient (III-28). Subject IV-36 had focal epilepsy with secondary generalisation. Slowing on EEG was reported in a number of family members which, although sometimes seen in (post-)epileptic states,³⁵ can hardly be regarded as diagnostic for epilepsy. We would logically have expected to detect some residual epileptic abnormalities on EEG in at least a few patients if the attacks were epileptic in nature. It is important to recall that (cortical) spreading depression may show epilepsy-like electrophysiological characteristics, with recordings of spreading depressions evolving into epileptic convulsions.³⁶ While 'pure' FHM without associated features may closely resemble 'common' migraine with aura, phenotypes on the severe end of the FHM spectrum may be more similar to epilepsy.

Paroxysmal ataxia has rarely been described in FHM2.^{11,16,19,37} Although five family members reported inability to move the affected limb(s) in a coordinated manner during attacks, we believe this was due to motor weakness or loss of sensation rather than ataxia.

One spouse (III-17) and only two family members had RLS: FHM patient III-25 had severe RLS, and IV-

44 had mild RLS without migraine. Therefore, although common migraine subtypes have been associated with RLS,⁵ we failed to find any association in our FHM2 family.

Various clinical symptoms in our family strongly resemble those of other migraine-associated syndromes. For instance, CSF pleocytosis reinforced the suspicion of (viral) infections in several patients. A headache syndrome that by definition includes CSF pleocytosis is transient headache and neurological deficits with cerebrospinal fluid lymphocytosis (HaNDL).¹ In this syndrome, as in our family, migraine(-like) headache and transient hemiparaesthesia, dysphasia, or hemiparesis can be present for several hours. Confusion, fever and uni- or bilateral slowing on EEG have also been reported in HaNDL patients but are not included in the diagnostic criteria.³⁸⁻⁴⁰ The only criterion excluding HaNDL in our family is that HaNDL, by definition, should resolve spontaneously within three months.¹ However, follow-up in HaNDL was mostly short compared to in our FHM2 family. Only one study has screened HaNDL patients for FHM1 *CACNA1A* mutations, but it failed to find any in 10 patients.³⁹ Screening of *ATP1A2* or *SCN1A* has never been reported in HaNDL patients.

The severe episodes in our FHM2 family may also resemble acute confusional migraine, which is characterised by a reversible acute confusional state with agitation, complete or partial amnesia, speech impairment and (bi- or unilateral) slow-wave EEG changes.⁴¹ Spreading depression has been suggested as a possible mechanism, possibly in the temporal lobe or brainstem. Minor head trauma has been reported as a common trigger for confusional migraine and, as observed in our family, hemiplegic migraine. Confusional migraine and hemiplegic migraine may thus be part of the same spectrum, but with different localisation and severity. The high prevalence of brainstem auras in our family might point at a localisation in the brainstem.

In conclusion, we provide the most comprehensive report to date of the most severe end of the clinical spectrum of FHM2 characterised by recurring long-lasting episodes of hemiplegic migraine, decreased consciousness, confusion, and fever. More awareness of such severe attacks as a migraine variant is dearly needed to prevent misdiagnoses and possibly harmful treatment. The striking clinical similarities with HaNDL, confusional migraine and brainstem aura, and, from a broader perspective, similarities with epilepsy, suggest possible common underlying mechanisms.

Clinical implications

- Familial hemiplegic migraine should be considered in patients with recurrent coma and fever.

- Clinical similarities of familial hemiplegic migraine with transient headache and neurological deficits with cerebrospinal fluid lymphocytosis (HaNDL), confusional migraine and brainstem aura, and, from a broader perspective, similarities with epilepsy, suggest possible common underlying mechanisms.

Acknowledgement: Author contributions are as follows: NP, acquisition and analysis of clinical/genetic data, drafting/revising the manuscript; DEB, analysis of clinical data, drafting/revising the manuscript; AHS, acquisition and analysis of clinical/genetic data, revising the manuscript; LSV, acquisition of genetic data, revising the manuscript; ATMH, acquisition of clinical data, revising the manuscript; JAVV, acquisition of clinical data, revising the manuscript; MDF, revising the manuscript, overall study supervision; AMJMvdM, revising the manuscript, genetic study supervision; JH, revising the manuscript, clinical study supervision; and GMT, revising the manuscript, clinical study supervision.

Declaration of conflicting interests: The authors declared the following potential conflicts of interest with respect to the research, authorship, and/or publication of this article: NP reports support for conference visits from Menarini. DEB, AHS, LSV, ATMH, JAVV, AMJMvdM and JH report no disclosures. MDF reports grants and consultancy or industry support from Medtronic and independent support from the European Community, the Netherlands Organisation for Scientific Research (NWO), the National Institutes of Health (NIH) and the Dutch Heart Foundation. GM Terwindt reports independent support from the NWO, the European Community, the Dutch Heart Foundation, and the Dutch Brain Foundation.

Funding: The authors disclosed receipt of the following financial support for the research, authorship, and/or publication of this article: This work was supported by grants from the NWO (VIDI 91711319 to GMT) and the European Community (FP7-EUROHEADPAIN – no. 602633 to MDF and AMJMvdM); the funding agencies had no role in the design or conduct of the study.

References

1. The International Classification of Headache Disorders, 3rd edition (beta version). *Cephalalgia* 2013;33:629–808.
2. de Vries B, Frants RR, Ferrari MD, et al. Molecular genetics of migraine. *Hum Genet* 2009;126:115–132.
3. Pelzer N, de Vries B, Kamphorst JT, et al. *PRRT2* and hemiplegic migraine: A complex association. *Neurology* 2014;83:288–290.
4. Thomsen LL, Eriksen MK, Roemer SF, et al. A population-based study of familial hemiplegic migraine suggests revised diagnostic criteria. *Brain* 2002;125:1379–1391.
5. Winter AC, Schurks M, Berger K, et al. Migraine and restless legs syndrome in men. *Cephalalgia* 2013;33:130–135.
6. Walters AS, LeBrocq C, Dhar A, et al. Validation of the International Restless Legs Syndrome Study

- Group rating scale for restless legs syndrome. *Sleep Med* 2003;4:121–132.
7. Thomsen LL, Olesen J and Russell MB. Increased risk of migraine with typical aura in probands with familial hemiplegic migraine and their relatives. *Eur J Neurol* 2003;10:421–427.
8. Jurkat-Rott K, Freilinger T, Dreier JP, et al. Variability of familial hemiplegic migraine with novel $ATP1A2$ Na^+/K^+ -ATPase variants. *Neurology* 2004;62:1857–1861.
9. Thomsen LL, Kirchmann M, Bjornsson A, et al. The genetic spectrum of a population-based sample of familial hemiplegic migraine. *Brain* 2007;130:346–356.
10. Echenne B, Ducros A, Rivier F, et al. Recurrent episodes of coma: an unusual phenotype of familial hemiplegic migraine with linkage to chromosome 1. *Neuropediatrics* 1999;30:214–217.
11. Spadaro M, Ursu S, Lehmann-Horn F, et al. A G301R Na^+/K^+ -ATPase mutation causes familial hemiplegic migraine type 2 with cerebellar signs. *Neurogenetics* 2004;5:177–185.
12. Kaunisto MA, Harno H, Vanmolkot KR, et al. A novel missense $ATP1A2$ mutation in a Finnish family with familial hemiplegic migraine type 2. *Neurogenetics* 2004;5:141–146.
13. Pierelli F, Grieco GS, Pauri F, et al. A novel $ATP1A2$ mutation in a family with FHM type II. *Cephalalgia* 2006;26:324–328.
14. Jen JC, Klein A, Boltshauser E, et al. Prolonged hemiplegic episodes in children due to mutations in $ATP1A2$. *J Neurol Neurosurg Psychiatry* 2007;78:523–526.
15. Vanmolkot KR, Stam AH, Raman A, et al. First case of compound heterozygosity in Na^+,K^+ -ATPase gene $ATP1A2$ in familial hemiplegic migraine. *Eur J Hum Genet* 2007;15:884–888.
16. Castro MJ, Nunes B, de Vries B, et al. Two novel functional mutations in the Na^+,K^+ -ATPase alpha2-subunit $ATP1A2$ gene in patients with familial hemiplegic migraine and associated neurological phenotypes. *Clin Genet* 2008;73:37–43.
17. Deprez L, Weckhuysen S, Peeters K, et al. Epilepsy as part of the phenotype associated with $ATP1A2$ mutations. *Epilepsia* 2008;49:500–508.
18. Lebas A, Guyant-Marechal L, Hannequin D, et al. Severe attacks of familial hemiplegic migraine, childhood epilepsy and $ATP1A2$ mutation. *Cephalalgia* 2008;28:774–777.
19. de Vries B, Stam AH, Kirkpatrick M, et al. Familial hemiplegic migraine is associated with febrile seizures in an FHM2 family with a novel de novo $ATP1A2$ mutation. *Epilepsia* 2009;50:2503–2504.
20. Riant F, Ducros A, Ploton C, et al. De novo mutations in $ATP1A2$ and $CACNA1A$ are frequent in early-onset sporadic hemiplegic migraine. *Neurology* 2010;75:967–972.
21. De Sanctis S, Grieco GS, Breda L, et al. Prolonged sporadic hemiplegic migraine associated with a novel de novo missense $ATP1A2$ gene mutation. *Headache* 2011;51:447–450.
22. Toldo I, Cecchin D, Sartori S, et al. Multimodal neuroimaging in a child with sporadic hemiplegic migraine: a contribution to understanding pathogenesis. *Cephalalgia* 2011;31:751–756.
23. Pisano T, Spiller S, Mei D, et al. Functional characterization of a novel C-terminal $ATP1A2$ mutation causing hemiplegic migraine and epilepsy. *Cephalalgia* 2013;33:1302–1310.
24. Roth C, Freilinger T, Kirovski G, et al. Clinical spectrum in three families with familial hemiplegic migraine type 2 including a novel mutation in the $ATP1A2$ gene. *Cephalalgia* 2014;34:183–190.

25. Kors EE, Terwindt GM, Vermeulen FL, et al. Delayed cerebral edema and fatal coma after minor head trauma: role of the *CACNA1A* calcium channel subunit gene and relationship with familial hemiplegic migraine. *Ann Neurol* 2001;49:753–760.
26. Ducros A, Denier C, Joutel A, et al. The clinical spectrum of familial hemiplegic migraine associated with mutations in a neuronal calcium channel. *N Engl J Med* 2001;345:17–24.
27. Stam AH, Luijckx GJ, Poll-The BT, et al. Early seizures and cerebral oedema after trivial head trauma associated with the *CACNA1A* S218L mutation. *J Neurol Neurosurg Psychiatry* 2009;80:1125–1129.
28. Katayama Y, Maeda T, Koshinaga M, et al. Role of excitatory amino acid-mediated ionic fluxes in traumatic brain injury. *Brain Pathol* 1995;5:427–435.
29. van den Maagdenberg AM, Pizzorusso T, Kaja S, et al. High cortical spreading depression susceptibility and migraine-associated symptoms in Ca(v)2.1 S218L mice. *Ann Neurol* 2010;67:85–98.
30. Leo L, Gherardini L, Barone V, et al. Increased susceptibility to cortical spreading depression in the mouse model of familial hemiplegic migraine type 2. *PLoS Genet* 2011;7:e1002129.
31. Ferrari MD, Klever RR, Terwindt GM, et al. Migraine pathophysiology: lessons from mouse models and human genetics. *Lancet Neurol* 2015;14:65–80.
32. Eikermann-Haerter K, Yuzawa I, Qin T, et al. Enhanced subcortical spreading depression in familial hemiplegic migraine type 1 mutant mice. *J Neurosci* 2011;31:5755–5763.
33. Theodore WH. The postictal state: effects of age and underlying brain dysfunction. *Epilepsy Behav* 2010;19:118–120.
34. Rocha S, Sousa F, Pinho J, et al. Recurrent post-ictal hyperthermia. *Arq Neuropsiquiatr* 2012;70:961–962.
35. Fisher RS and Engel JJ Jr. Definition of the postictal state: when does it start and end? *Epilepsy Behav* 2010;19:100–104.
36. Dreier JP, Major S, Pannek HW, et al. Spreading convulsions, spreading depolarization and epileptogenesis in human cerebral cortex. *Brain* 2012;135:259–275.
37. Fernandez DM, Hand CK, Sweeney BJ, et al. A novel *ATP1A2* gene mutation in an Irish familial hemiplegic migraine kindred. *Headache* 2008;48:101–108.
38. Gomez-Aranda F, Canadillas F, Marti-Masso JF, et al. Pseudomigraine with temporary neurological symptoms and lymphocytic pleocytosis. A report of 50 cases. *Brain* 1997;120:1105–1113.
39. Chapman KM, Szczygielski BI, Toth C, et al. Pseudomigraine with lymphocytic pleocytosis: a calcium channelopathy? Clinical description of 10 cases and genetic analysis of the familial hemiplegic migraine gene *CACNA1A*. *Headache* 2003;43:892–895.
40. Nelson S. Confusional State in HaNDL Syndrome: Case Report and Literature Review. *Case Rep Neurol Med* 2013;2013:317685.
41. Pacheva I and Ivanov I. Acute confusional migraine: is it a distinct form of migraine? *Int J Clin Pract* 2013;67:250–256.