



Universiteit
Leiden
The Netherlands

High-frequency EPR on high-spin transitions-metal sites

Mathies, G.

Citation

Mathies, G. (2012, March 1). *High-frequency EPR on high-spin transitions-metal sites*. Casimir PhD Series. Retrieved from <https://hdl.handle.net/1887/18552>

Version: Not Applicable (or Unknown)

License: [Leiden University Non-exclusive license](#)

Downloaded from: <https://hdl.handle.net/1887/18552>

Note: To cite this publication please use the final published version (if applicable).

Cover Page



Universiteit Leiden



The handle <http://hdl.handle.net/1887/18552> holds various files of this Leiden University dissertation.

Author: Mathies, Guinevere

Title: High-frequency EPR on high-spin transition-metal sites

Issue Date: 2012-03-01

Chapter 2

Continuous-wave EPR at 275 GHz: Application to high-spin Fe^{3+} systems

The 275 GHz electron-paramagnetic-resonance spectrometer we reported on in 2004 has been equipped with a new probe head, which contains a cavity especially designed for operation in continuous-wave mode. The sensitivity and signal stability achieved with this new probe head is illustrated with 275 GHz continuous-wave spectra of a 1 mM frozen solution of the complex Fe(III)-ethylenediamine tetra-acetic acid (EDTA) and of 10 mM frozen solutions of the protein rubredoxin, which contains Fe^{3+} in its active site, from three different organisms. The high quality of the spectra of the rubredoxins allows the determination of the zero-field splitting parameters with an accuracy of 0.5 GHz. The success of our approach results partially from the enhanced absolute sensitivity, which can be reached using a single-mode cavity. At least as important is the signal stability that we were able to achieve with the new probe head.

G. Mathies, H. Blok, J.A.J.M. Disselhorst, P. Gast, H. van der Meer, D.M. Miedema, R.M. Almeida, J.J.G. Moura, W.R. Hagen and E.J.J. Groenen, *J. Magn. Res.*, 210 (2011) 126-132.

2.1 Introduction

The understanding of complex electron-paramagnetic resonance (EPR) spectra of the active sites of metalloproteins is often greatly advanced by studies at more than one microwave frequency. High-frequency/high-field (HF) EPR is particularly useful for systems that have a large zero-field splitting. Integer spin systems tend to be EPR silent at conventional microwave frequencies and for half-integer spin systems the ease and precision by which the zero-field splitting parameters can be determined is enhanced. The goal of this work is to extend the possibilities of HF EPR for metalloproteins.

The HF EPR spectra of metalloproteins with a zero-field splitting on the order of the microwave quantum are difficult to record. These spectra cover large field ranges. Due to conformational strain the resonances in the HF EPR spectra are broad, and line widths of 1 T are no exception. Moreover, the available amount of protein is often limited and the same holds for the concentration. Relaxation times can be very short, which makes only continuous-wave (cw) EPR feasible. In order to achieve our goal, we need a HF cw EPR spectrometer with high sensitivity and signal stability, which is maintained while using a large modulation amplitude.

High-frequency/high-field EPR was introduced by the group of Lebedev in Moscow. [19–21] Their spectrometer operated at a frequency of 140 GHz, which is the highest frequency at which conventional waveguides can be used. Indeed, HF EPR comes with technical difficulties. Major progress was made by the introduction of quasi-optical techniques and in the development of high-frequency microwave components and high-field magnets. Spectrometers that operate in cw mode at frequencies above 140 GHz are found in specialized research groups at Cornell (250 GHz [22] and 100-300 GHz [23]), in Grenoble (160 - 525 GHz [24–26]), St. Andrews (80 - 200 GHz [27]), Berlin (360 GHz [28]), Tallahassee (24 GHz - 3 THz [29, 30]), Frankfurt (180 GHz [31]), Leiden (275 GHz [9, 32]) and Mülheim an der Ruhr (244 GHz [33]). This year Bruker has released a spectrometer that operates at 263 GHz.¹ For recent reviews see references 34 and 35.

In 2004 we reported on the construction of a cw and pulsed EPR spectrometer operating at 275 GHz. [9] This spectrometer is equipped with a multi-functional TE₀₁₁ cylindrical cavity, which has slits to allow optical access and ENDOR. [32] With this cavity it is possible to measure cw EPR of paramagnetic species that have narrow resonances (for instance spin-labels), but spectra of species that show broad resonances are poor. Our approach to improve the quality of these spectra is to equip the spectrometer with a second probe head, which contains a single-mode cavity optimized for operation in cw mode.

Currently all other HF cw EPR spectrometers operate in non-resonant transmission or reflection or use a Fabry-Perot interferometer. However the use of a

¹<http://www.bruker-biospin.com/e780.html>

single-mode cavity has several advantages. First, one can profit from the increase of the absolute sensitivity with an increasing microwave frequency, which theory predicts. [36–39] Secondly, the high B_1 field at the sample, which can be generated with a single-mode cavity, is advantageous for fast-relaxing species. Finally, the small sample volume makes it relatively easy to achieve a high, homogeneous modulation field throughout the sample. Drawbacks of using a single-mode cavity could be sample handling and the problem of constructing a single-mode cavity of the dimensions that fit 275 GHz, but the former is not a problem for solutions of proteins due to the capillary force and we already showed that we could overcome the latter.

An ever persisting problem in cw HF EPR is signal stability. The high magnetic field induces strong Lorentz forces on the modulation coil, which cause vibrations in the probe head at the modulation frequency or its harmonics. This is called microphonics. [27, 40, 41] This interference tends to be in phase with the modulated EPR signal and can seriously deteriorate the signal-to-noise ratio. This is particularly a problem when recording broad resonances with a large modulation amplitude. Operation in induction mode can reduce the effect of microphonics on the EPR signal [27, 42], but this is not an option when a single-mode cavity is used. We show that the use of a single-mode cavity also allows the reduction of the influence of microphonics such that high-quality spectra of frozen solutions of low concentrations of metalloproteins can be recorded.

The achieved sensitivity and stability is illustrated by 275 GHz cw EPR spectra of a 1 mM frozen solution of the complex Fe(III)-ethylenediamine tetra-acetic acid (EDTA) and of 10 mM frozen solutions of the protein rubredoxin, which contains Fe^{3+} in its active site. The iron ion is in a high-spin state, which leaves five unpaired electrons ($S = 5/2$). We have chosen Fe(III)-EDTA as a model complex to demonstrate the performance of our spectrometer, because of its representative spectrum and because several HF EPR studies have been performed on frozen solutions of Fe(III)-EDTA on other spectrometers. [33, 43–45] Rubredoxins are small proteins (typically 50–54 amino acids) that are found in sulfur-metabolizing bacteria and archaea, in which they participate in single-electron transfer. They have been studied extensively. [10] The iron ion in the active site is approximately tetrahedrally coordinated to the sulfur atoms of four cysteine residues occurring in a Cys-x-x-Cys-Gly and a Cys-Pro-x-Cys-Gly segment. Our studies show that we are able to acquire high-quality HF cw EPR spectra of small amounts of dilute frozen solutions of high-spin Fe^{3+} systems.

2.2 Experimental

2.2.1 The cw probe head

The cw probe head is similar to the probe head that contained the general purpose cavity. [9] This probe head can be placed into a helium flow cryostat located in the room-temperature bore of the superconducting magnet. The microwaves are guided through an oversized corrugated waveguide, which ends in a corrugated tapered transition to a fundamental-mode rectangular waveguide from where the microwaves couple into the cavity.

Figure 2.1 shows a drawing of the cavity. The design considerations for the cw cavity were to have a high quality factor and to minimize microwave leakage, since this could destabilize the EPR signal. The cavity is a 14 mm long cylinder with a diameter of 1.40 mm in a massive bronze block, which was made by electrical discharge machining. It was polished with diamond paste and gold plated. At both open ends of the cylinder a bronze plunger enters, which has a choke joint at the front. We tune the cavity to the microwave frequency of 275.7 GHz by moving the plungers in or out of the cylinder using a set of gears. The length of the cavity can be varied in this way between 0.80 and 1.40 mm with a position accuracy of 1 μm . A quartz sample tube with outer diameter 0.25 mm can be inserted into the cavity through the plungers. With an inner diameter of 0.15 mm the sample volume inside the cavity is 25 nl. The coupling between the fundamental-mode rectangular waveguide and the cavity is varied by rotating the cavity-plunger-gear combination around a vertical axis through the rectangular waveguide and the coupling hole.

Also shown in Figure 2.1 is the modulation coil. The modulation coil consists of 80 turns of 0.2 mm diameter copper wire, which are encased in Stycast epoxy. The coil is placed on a solid rexolite mount, which is fixed on a pertinax plate, which is attached to the end of the probe head. The distance between the coil and the cavity block is 0.5 mm, and the two are mechanically isolated. The modulation coil leads are fixed to the mount with Stycast and go up to the top of the probe head as a twisted pair. The resistance of the modulation coil at room temperature is about 1 Ω . The modulation amplitude is 7 mT/A peak-peak.¹

2.2.2 Samples

Fe(III)-EDTA sodium salt (Sigma-Aldrich Chemie GmbH) was dissolved in an aqueous solution which was kept at pH 5 by a citric acid buffer. Samples consisted of one part of this solution and one part glycerol. Rubredoxin from *Desulfovibrio gigas* [14, 46] was purified according to a previously reported method. [47] To ensure that no other metal forms of rubredoxin, other than iron, were present in the sample, the

¹After submission of this work the design of the mount of the modulation coil was altered to improve the endurance against repeated cooling cycles. See Appendix B.

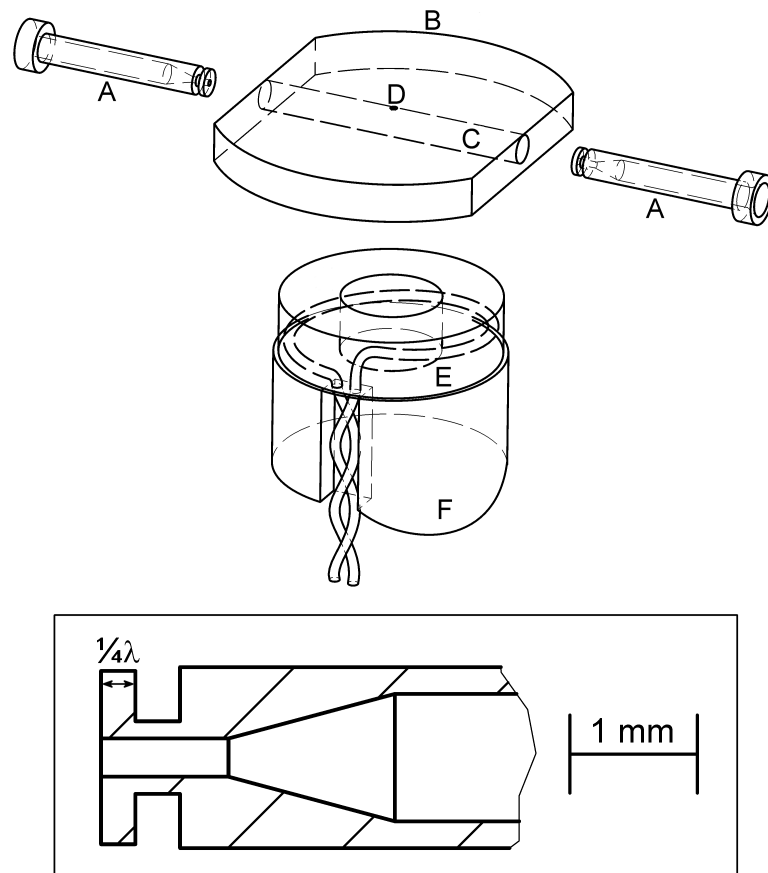

Figure 2.1: Schematic drawing of the 275 GHz cw cavity and the modulation coil. A: plungers, B: cavity block, C: cavity, D: coupling hole, E: modulation coil encased in Styrcast (for clarity only one turn is depicted) F: modulation coil mount. The inset shows the choke joint at the end of the plungers in detail.

2. Continuous-wave EPR at 275 GHz: Application to high-spin Fe³⁺ systems

protein was injected in a 6 ml Resource Q column (GE Biosciences) equilibrated with 10 mM Tris-HCl pH 7.6 buffer and eluted in a linear NaCl gradient (0 - 500 mM in buffer). Throughout the purification procedure the purity of the rubredoxin fractions was assessed by SDS-PAGE, and by measuring the A_{280}/A_{493} ratio, which for pure Fe-rubredoxin is 2.4. Rubredoxin from *Pyrococcus furiosus* [15, 48] and *Megasphaera elsdenii* were prepared as described in reference [49] and [50] respectively.

2.3 Results

2.3.1 Absolute sensitivity

In Figure 2.2 the room temperature 275 GHz cw EPR spectrum of a 10^{-4} M solution of the spin label TEMPO (Sigma-Aldrich Chemie GmbH) in toluene is shown. This spectrum was recorded using a modulation amplitude of 0.05 mT, a time constant of 100 ms and a microwave power of $50 \mu\text{W}$.¹ The three lines originate from the hyperfine interaction with the ¹⁴N nuclear spin ($I = 1$). We determine the absolute sensitivity of our spectrometer from this spectrum. Assuming that the volume of the sample that contributes to the EPR signal is one-third of the sample volume inside the cavity, the spectrum originates from 10^{12} spins. The signal-to-noise ratio of the spectrum shown in Figure 2.2 is 320. The total line width of the spectrum is $3 \times 0.35 \text{ mT} = 1.05 \text{ mT}$. This gives an absolute sensitivity of $8 \cdot 10^8 \text{ spins/mT}/\sqrt{\text{Hz}}$.

2.3.2 Operating the spectrometer in cw mode

Microphonics are observed as an unstable component at the modulation frequency in the frequency spectrum of the output voltage of the detection diode. This component, which is not related to absorption of microwaves by the paramagnetic sample, becomes stronger as the magnetic field strength is increased. Tuning the cavity by moving the plungers with care brings down this modulation frequency pick-up. If the cavity is properly tuned the reflection of the microwaves by the cavity is at a minimum, which means that a small detuning of the cavity will hardly affect the reflection. It is thus necessary to tune at a high magnetic field strength where no EPR signal is observed.

The high-spin Fe³⁺ spectra are recorded with a scan rate of 2 mT/s and acquiring these spectra takes hours. The microwave frequency of the current bridge of our spectrometer is fixed. This means that we have to take care to keep conditions inside the cryostat constant. Small variations in temperature and helium pressure inside

¹The power output of the microwave bridge is 1 mW, but the maximum power that can be used in cw experiments at room temperature is about $50 \mu\text{W}$. Coupling of the microwaves into the cavity is not fully critical and at higher output powers reflected microwaves cause saturation in the detection path.

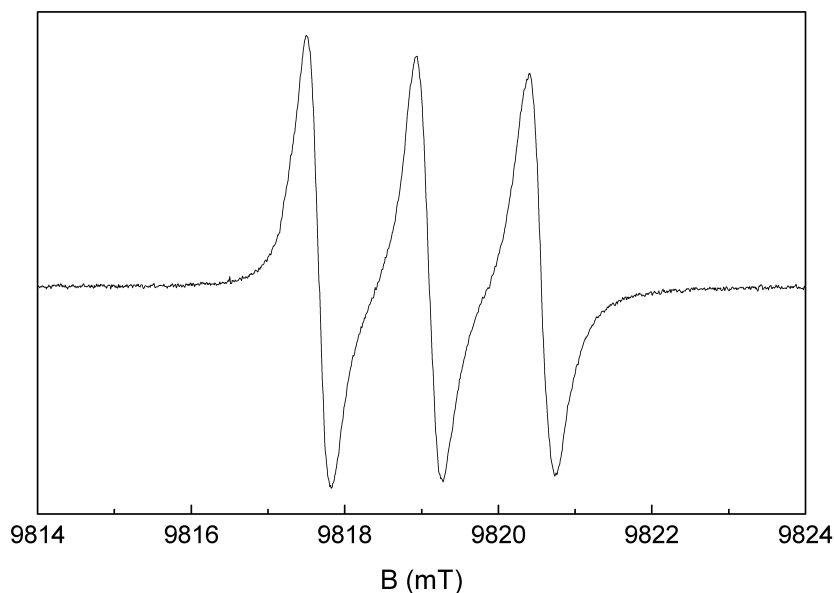

Figure 2.2: The room temperature cw EPR spectrum at 275 GHz of a 10^{-4} M solution of the spin label TEMPO in toluene. Experimental conditions: modulation amplitude: 0.05 mT, time constant: 100 ms, microwave power: $50 \mu\text{W}$.

the flow cryostat may detune the cavity, which leads to drift of the baseline of the EPR spectrum and increases the effect that microphonics have on the EPR signal. The use of a high modulation amplitude is essential to detect the broad resonances of Fe^{3+} . This makes minimization of microphonics even more challenging. In practice a modulation current of about 600 mA was found to be optimal. No dependence of the microphonics on the modulation frequency was found. The modulation frequency was chosen between 1 and 2 kHz.

A decrease of the sample temperature does not automatically mean an increase of the sensitivity of the spectrometer. When the probe head is cooled by cold helium gas, the circumstances in the cavity, which have a strong influence on the reflected microwaves, tend to vary more strongly. This has a negative effect on the signal stability. Also the quality factor of the cavity increases strongly as it is cooled down, due to an increase in the conductivity of the gold-plated walls of the cavity. An increased quality factor means an increase in the effect on the EPR signal of a slight detuning of the cavity which means that microphonics become more of a problem. In order to compensate for this effect we had to attenuate the microwave power in order to record the Fe^{3+} spectra.

2. Continuous-wave EPR at 275 GHz: Application to high-spin Fe³⁺ systems

2.3.3 High-spin Fe³⁺ spectra

In Figure 2.3 the cw EPR spectra recorded at 275 GHz of a 1 mM frozen solution of Fe(III)-EDTA are shown. The recorded spectra cover 6 T. Around 6.6 T a resonance with a width of 0.5 T is observed. As the temperature is increased, this resonance decreases in intensity, while the resonances in the $g = 2$ region gain intensity ($g = 2$ corresponds to a magnetic field of 9.85 T for 275.7 GHz). In Figure 2.4 the $g = 2$ region is shown in detail. The signal-to-noise ratio for the resonance around 9.8 T (peak to peak) at 15 K is 130. Another resonance is observed around 8.2 T, which is equidistant with the resonances around 6.6 T and 9.8 T. Two more resonances are observed around 10.2 T and 11.3 T. Note that the resonances are broadest at the extremes of the spectrum. Resonances that do not originate from Fe(III)-EDTA are present in the spectra. At temperatures above 5 K in the $g = 2$ region six lines due to a manganese impurity could be properly recorded by scanning slowly with a lower modulation amplitude. The resonance at 7.6 T is due to a contamination of the frozen sample solution with molecular oxygen. [51] The origin of the resonance that is observed at 9.6 T in the 5 K spectrum is not known.

Figure 2.5 shows cw EPR spectra recorded at 275 GHz of a frozen solution of the protein rubredoxin from *D. gigas*. The recorded spectra cover 12 T and resonances of a width of 1 T are observed. The resonances observed at low field (up to 4 T) lose intensity with temperature. Broad resonances around 6.8 T, 8.7 T, 10.2 T and 11.3 T increase in intensity upon an increase in temperature from 5 to 10 K. In the $g = 2$ region resonances at 9.5 T and 9.7 T appear at higher temperature. The signal-to-noise ratio for the resonance at 9.7 T (peak to peak) at 25 K is 200. At 4.4 T and 7.6 T resonances due to molecular oxygen are seen. [51] As in the Fe(III)-EDTA spectra, a resonance of unknown origin is observed at 9.6 T in the 5 K spectrum. The narrow resonance at 9.8 T ($g \approx 2$) that is visible at 10 and 25 K is due to an impurity.

In Figure 2.6 cw EPR spectra recorded at 275 GHz of rubredoxin from three different species are compared. The spectra are similar, but the precise position of the resonances around 6.8 T, 8.7 T, 10.2 T and 11.3 T varies for the different species by a few tens of mT. Also the shape of the spectra of rubredoxin from *P. furiosus* and in particular from *M. elsdenii* differs from that of the spectrum from *D. gigas*. For these two species of rubredoxin a broad background signal seems to be present. A manganese resonance is observed in the spectrum of rubredoxin from *P. furiosus*.

2.4 Analysis

The following spin Hamiltonian was used to analyze the spectra of high-spin Fe³⁺ ($S = 5/2$).

$$H = \mu_B \vec{B} \cdot \vec{g} \cdot \vec{S} + \vec{S} \cdot \vec{D} \cdot \vec{S} \quad (2.1)$$

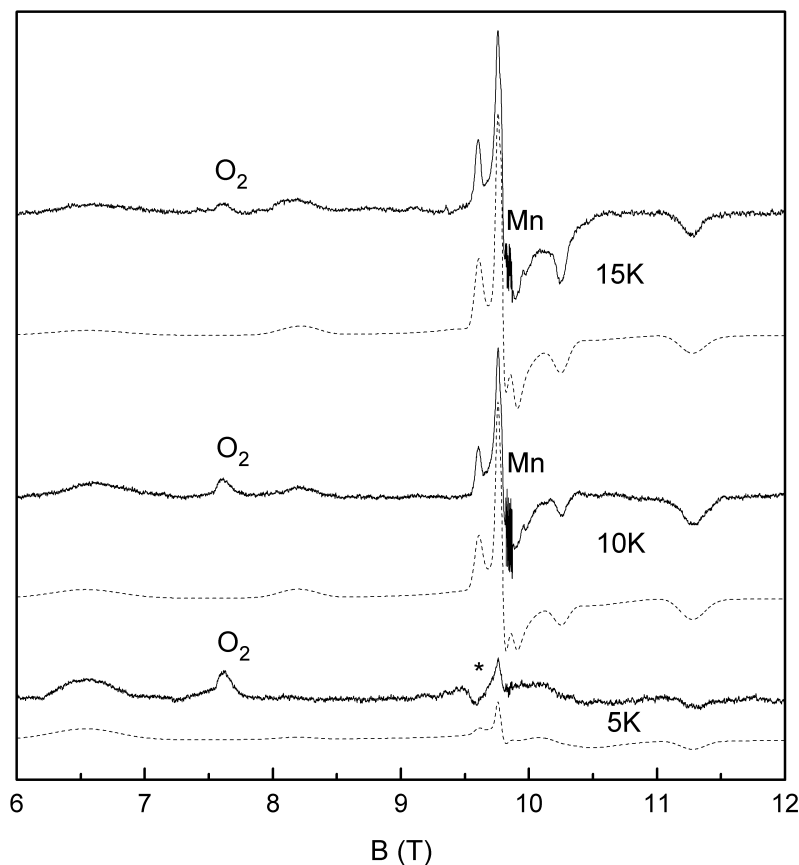

Figure 2.3: The 275 GHz cw EPR spectra of a 1 mM frozen solution of the model complex Fe(III)-EDTA at three temperatures. Experimental conditions: modulation amplitude: 3 mT, time constant: 1 s, scan rate: 2 mT/s, microwave power: 1 μ W. Spectra were recorded at least twice to ensure reproducibility of all features. The solid lines are the experimentally observed spectra and the dashed lines are the spectra calculated by EasySpin with the parameters given in Table 2.1. The origin of the resonance marked with a \star in the 5 K spectrum is unknown. In the 10 K spectrum a weak EPR signal between 8.5 and 9.5 T that does not originate from the Fe(III)-EDTA was subtracted for clarity.

The first term is the electron Zeeman term. A first-order contribution from spin-orbit coupling induces g -anisotropy, but this effect is expected to be small, since high-spin Fe^{3+} has a ${}^6S_{5/2}$ ground state. The second term is a field independent fine-structure term (the zero-field splitting, ZFS). The tensor \vec{D} mainly consists of a second-order contribution from spin-orbit coupling. It is symmetric and taken traceless, and it

2. Continuous-wave EPR at 275 GHz: Application to high-spin Fe³⁺ systems

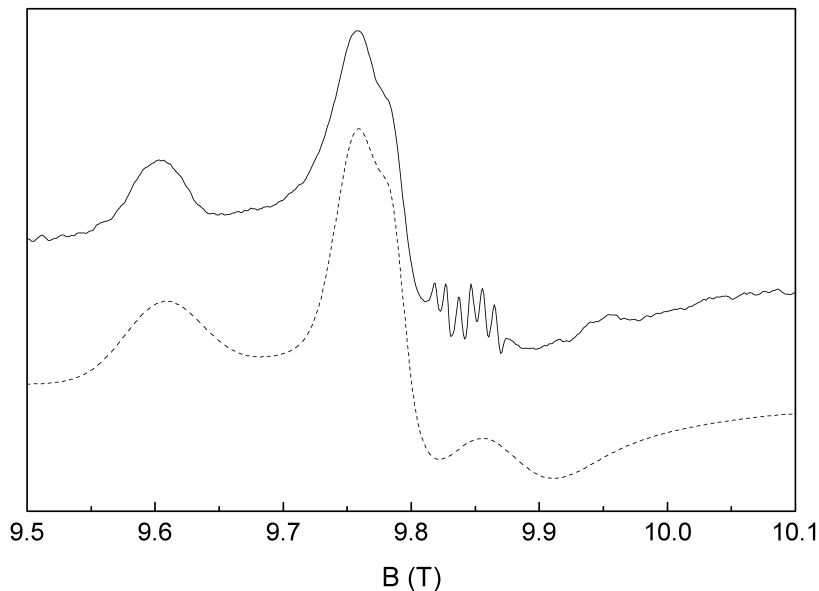

Figure 2.4: Detail of the 275 GHz cw EPR spectrum of a 1 mM frozen solution of the model complex Fe(III)-EDTA at 15 K in Figure 2.3. The solid line is the experimentally observed spectrum and the dashed line is the spectrum calculated by EasySpin with the parameters given in Table 2.1.

can be characterized by two parameters, D and E .

$$D = 3/2D_z, E = 1/2(D_x - D_y) \quad (2.2)$$

The rhombicity of \vec{D} is given by the ratio $\lambda = E/D$. The principal axes are chosen such that $|D_z| > |D_y| > |D_x|$ and thus $0 < \lambda < 1/3$.

In the weak-field limit ($\vec{S} \cdot \vec{D} \cdot \vec{S} \gg \mu_B \vec{B} \cdot \vec{g} \cdot \vec{S}$) the effective $S = 1/2$ picture, in which the effect of the zero-field splitting can be incorporated in an effective g -tensor, is applicable. This is the case when rubredoxin is studied at X-band. The absolute value and sign of D can be determined only indirectly from the temperature dependence of the spectra and the effective g -values at which resonances are observed. [52]

In the high-field limit ($\vec{S} \cdot \vec{D} \cdot \vec{S} \ll \mu_B \vec{B} \cdot \vec{g} \cdot \vec{S}$) the frozen solution spectrum shows the transitions associated with the principal axes of the g -tensor, because the energy levels vary linearly with the field strength. At low temperature the large polarization effect greatly simplifies the spectra and the sign of D can be determined from the spectra directly.[45] Transitions arising from one principal direction are separated in

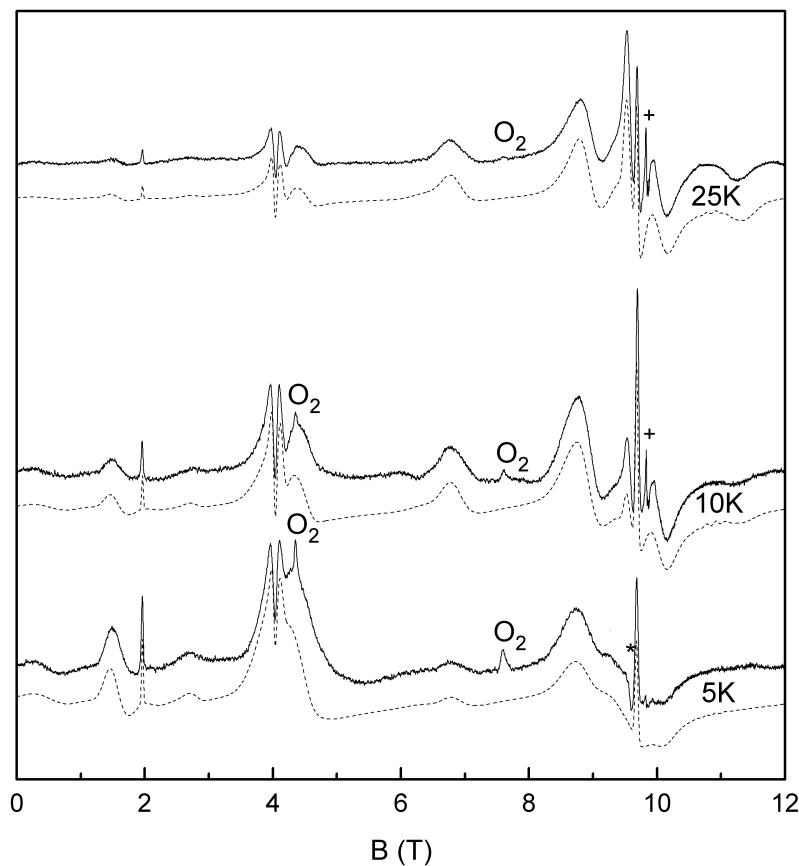

Figure 2.5: The 275 GHz cw EPR spectra of a 10 mM frozen solution of the protein rubredoxin from *D. gigas* at three temperatures. Experimental conditions: modulation amplitude: 4 mT, time constant: 1 s, scan rate: 2 mT/s, microwave power: 1 μ W. The solid lines are the experimentally observed spectra and the dashed lines are the spectra calculated by EasySpin with the parameters given in Table 2.1. The origin of the resonance marked with a \star in the 5 K spectrum is unknown. The resonance marked with a $+$ in the 10 K spectrum derives from an impurity.

field by:

$$\Delta B = \frac{3D_i}{\mu_B g_i} \quad (2.3)$$

where i is x , y or z . The case of Fe(III)-EDTA at 275 GHz is near the high-field limit. Resonances are observed at 6.6 T, 8.2 T and 9.85 T. These resonances are roughly 1.6 T apart, which gives an absolute value of about 15 GHz for the largest principal value of \vec{D} , D_z . Since these resonances are observed below $g = 2$, the sign of D_z is negative. A resonance is observed at 11.3 T, which is 1.45 T above 9.85 T. From

2. Continuous-wave EPR at 275 GHz: Application to high-spin Fe³⁺ systems

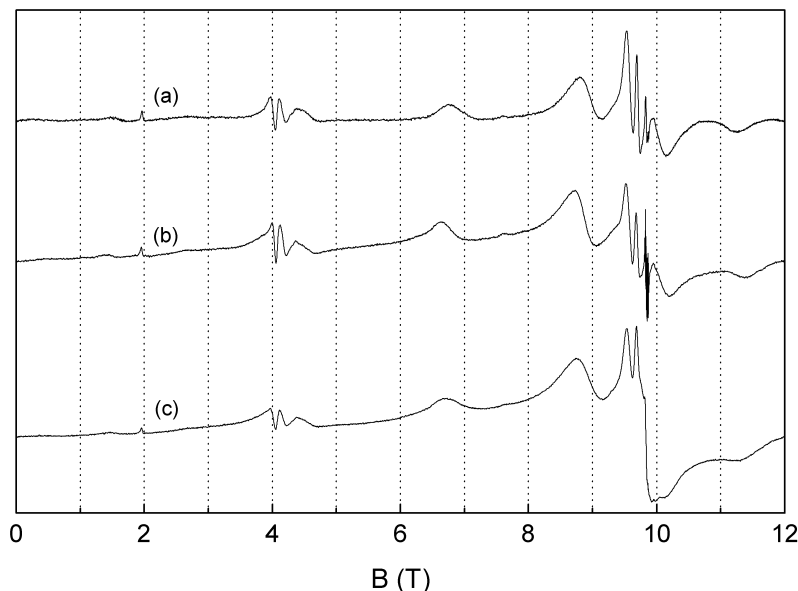

Figure 2.6: The cw EPR spectra of 10 mM frozen solutions of rubredoxin from three different organisms at 25 K: (a) *D. gigas*, (b) *P. furiosus*, and (c) *M. elsdenii*. The vertical dashed lines are displayed to guide the eye to the differences between the three spectra. Simulations of the spectra of rubredoxin from *P. furiosus* and *M. elsdenii* are presented in Appendix A.

this we estimate $D_y \approx 14$ GHz, which gives $D \approx -22.5$ GHz and $E \approx -6.5$ GHz.

In the intermediate region the ZFS-term and the Zeeman term are similar in size. This is the situation of rubredoxin at 275 GHz. As can be seen in Figure 2.5 this gives rise to complex spectra. The way to extract the spin Hamiltonian parameters from the observed spectra is by comparison with spectra that were calculated by numerical diagonalization of the spin Hamiltonian. For this we used EasySpin. [6] We assume that the D - and g -tensor are collinear.

The spin Hamiltonian parameters that were found to fit the experimental spectra of the different types of rubredoxin best are shown in Table 2.1. The resonances below 4 T are due to forbidden transitions. The shape of the resonance around 4 T strongly depends on λ . The positions of the 6.8 T, 10.1 T and 11.3 T resonances are determined by the values of E and D . The position of the resonance at 8.7 T is influenced by both D and g_x . The values of g_y and g_z are determined by the positions of the 9.5 T and 9.7 T resonances respectively.

Also the Fe(III)-EDTA spectra were compared with spectra calculated with EasySpin and the parameters with which these spectra were best reproduced are summarized in Table 2.1. The value of D_z is determined by the position of the resonance around 6.6 T. The value of g_z must be slightly higher than g_x and g_y to

reproduce the shape of the spectrum just below 9.8 T.

	D (GHz)	E (GHz)	λ	g_x	g_y	g_z	D -strain (GHz)	E -strain (GHz)
Fe(III)-EDTA	-23.3	-6.3	0.27	2.004	2.004	2.005	4.3	1.7
<i>D. gigas</i> Rd	47.5	12.5	0.26	2.02	2.021	2.014	9.0	2.5
<i>P. furiosus</i> Rd	49.5	13.0	0.26	2.02	2.021	2.014	9.0	2.5
<i>M. elsdenii</i> Rd	48.5	13.0	0.27	2.02	2.021	2.014	9.0	2.5

Table 2.1: Spin Hamiltonian parameters that best reproduce the experimental spectra. The strains are quantified by the FWHM of the Gaussian distribution in the D - and E -values. Errors are estimated from the sensitivity of the calculated spectrum to a variation in a parameter: ± 0.5 GHz for the zero-field splitting parameters, ± 0.001 for the g -values and ± 0.5 GHz for the strains. The spectra of rubredoxin are relatively insensitive to a change in g_x . The error in this parameter is estimated to be ± 0.005 . The error in the measured magnetic field values was estimated to be 2 mT at 10 T and gives a negligible contribution.

The resonances of the Fe(III)-EDTA are broader when they are further away from $g = 2$. Transitions between energy levels that have the larger $|m|$ are broader, which points to the presence of D - and E -strain. In fact the shape of the observed spectra of both Fe(III)-EDTA and rubredoxin could only be reproduced by taking into account D - and E -strain in the EasySpin calculations (see Table 2.1).¹ No additional isotropic line-broadening was taken into account.

2.5 Discussion

The modifications to our spectrometer have made it possible to acquire high-quality cw EPR spectra at 275 GHz on 25 nl of a 1 mM frozen solution of the high-spin Fe³⁺ model complex Fe(III)-EDTA. We have also acquired high-quality spectra of 10 mM frozen solutions of the high-spin Fe³⁺ protein rubredoxin. The signal-to-noise ratio of these spectra is such that a lower protein concentration could have been used. The sensitivity and baseline stability of our spectrometer are high enough to resolve resonances that have a width of 1 T in spectra that are acquired at low temperature, range over 12 T and require several hours to record. The quality of the spectra allows accurate determination of the parameters of the spin Hamiltonian by comparison to

¹In the online documentation on EasySpin the author notes that the effect of strains on the spectra are calculated using an approximation, which is only applicable as long as the strain distribution width is much smaller than the parameter itself. In our situation this is not immediately clear. However spectra that were calculated by running a loop over a distribution of spin Hamiltonian parameters matched almost exactly with the spectra that were calculated in the (much less time consuming) EasySpin approximation. The approximation is thus valid.

2. Continuous-wave EPR at 275 GHz: Application to high-spin Fe³⁺ systems

spectra that were calculated from numerical diagonalization of the spin Hamiltonian while taking into account line broadening due to D - and E -strain.

The sensitivity that can be obtained with a particular spectrometer for a particular system in practice depends on the width of the resonance that has to be recorded, the modulation amplitude that can be generated and the microwave power that can be applied. The spectrum shown in Figure 2.2 from which we determined the absolute sensitivity of our spectrometer to be $8 \cdot 10^8$ spins/mT/ \sqrt{Hz} was acquired at maximum power and with a modulation amplitude that was optimal with respect to the line width.

The absence of slits and the complete closure of the cw cavity for microwaves by means of the choke joints assures that the quality factor of the cw cavity is higher than that of the general purpose cavity. [9] To estimate this increase we have determined the length of a $\pi/2$ -pulse for a single crystal of gamma-ray irradiated lithium fluoride ($S = 1/2$). At room temperature this is 160 ns for the cw cavity and approximately 340 ns for the general purpose cavity. This corresponds to a twofold increase in the B_1 -field in the cavity and in the signal amplitude. Continuous-wave spectra recorded on TEMPO in toluene show that the absolute sensitivity at room temperature is approximately five times higher for the cw cavity. The additional increase is mainly due to improved coupling of the microwaves into the cavity.

The absolute sensitivity of our spectrometer is on the high end of the range of sensitivities achieved with other HF EPR spectrometers. [22–31, 33] In order to study high-spin metalloproteins by cw HF EPR, high sensitivity is a primary condition that must be fulfilled. Signal stability is as important, particularly for metalloproteins that show a large zero-field splitting. Hence, during low temperature experiments temperature and pressure in the cryostat must be controlled precisely. And microphonics must be minimized. The construction of a cavity that is completely closed for microwaves and the specific construction of the modulation coil have been instrumental in accomplishing this.

The quality of the spectra that we recorded on a 25 nl sample of 1 mM Fe(III)-EDTA is comparable to the quality accomplished by other authors at 285 and 244 GHz at concentrations that were higher by a factor of 60 or more. [33, 43, 44] The quality of the spectra acquired at 230 GHz as reported in [45] at 10 mM is slightly better than ours.

The chemistry of Fe(III)-EDTA in solution is very complex, which makes it difficult to compare spin Hamiltonian parameters found in various experiments. The coordination of the iron ion in EDTA is pH dependent as is its EPR spectrum. [53, 54] A study of Fe(III)-EDTA in the form of a crystalline powder of Co(III)-EDTA with impurities of ferric ions, ratio Co:Fe = 50:1, at X-band and Q-band gave $|D| = 24.9$ GHz and $E/D = 0.31$. [55] The X-band spectrum from this study is reproduced with the parameters that were found from our experiments, except for the D - and E -strain which must be set to zero and instead an isotropic line broadening of 3 mT must be introduced. Our spin Hamiltonian parameters resemble closely

the values reported in reference [45]. In this study no D - and E -strain were taken into account.

Rubredoxin from several organisms has been studied at the standard EPR frequency of 9 GHz. [10, 52, 56–58] The D -values are around 50 GHz and the rhombicity parameter λ is around 0.26. This is in line with our results. The natural variety in the amino-acid sequences of rubredoxins from different organisms results in small variations in the geometrical structure of the active site of the protein. [14, 15] This will lead to subtle variations in the electronic structure of the active site, which can very well be studied by HF EPR. [59] Figure 2.6 shows that at 275 GHz a change of 1 GHz in one of the zero-field-splitting parameters is obvious from the spectra. The quality of our spectra is such that we are able to determine the zero-field-splitting parameters with an accuracy of 0.5 GHz by comparison to spectra calculated from numerical diagonalization of a spin Hamiltonian.

The D - and E -strain that had to be included in the simulations to reproduce the experimental spectra is comparable in size for the model complex and the protein. A considerable active-site heterogeneity is common for proteins, but not for Fe(III)-EDTA. Heterogeneity in the coordination of the iron ion could be an explanation. [60]

Börger *et al.* interpreted the complicated frozen solution spectrum of rubredoxin at X-band by including E/D -strain into their simulations. [58] From X-band spectra the strain in D and E can not be determined independently. They found a Gaussian distribution of E/D with a width of $\sigma_{E/D} = 0.03$. If we take the square root of the sum of the squares of our relative D - and E -strain, we find a relative E/D -strain of 11%. On average the value of E/D found for rubredoxin is 0.26, which gives a value of 0.03 for $\sigma_{E/D}$.

The precise positions of the resonances around $g = 2$ made it necessary for both Fe(III)-EDTA and rubredoxin to include a small g -anisotropy in the simulations. The high magnetic field at which the spectra were recorded made it possible to determine reliable g -values directly. These g -values are clearly different from the g -values that were determined earlier, indirectly, from X-band spectra. [58]

2.6 Conclusion

Our studies of high-spin Fe^{3+} systems show that we are able to acquire high-quality HF cw EPR spectra of frozen solutions of small amounts of modest size metallo-proteins. The quality of the spectra is high enough to observe g -anisotropy and to determine the zero-field-splitting parameters with an accuracy of 0.5 GHz.

The success of our approach results partially from the enhanced absolute sensitivity that can be reached using a single-mode cavity, which was specifically constructed to be used for cw HF EPR. At least as important is the achieved signal stability.

2. Continuous-wave EPR at 275 GHz: Application to high-spin Fe³⁺ systems
