



Universiteit
Leiden
The Netherlands

Inner aspect and telicity : the decompositional and the quantificational nature of eventualities at the syntax-semantics interface

Arsenijevic, B.

Citation

Arsenijevic, B. (2006, October 11). *Inner aspect and telicity : the decompositional and the quantificational nature of eventualities at the syntax-semantics interface*. LOT dissertation series. LOT, Utrecht. Retrieved from <https://hdl.handle.net/1887/4862>

Version: Not Applicable (or Unknown)

License: [Licence agreement concerning inclusion of doctoral thesis in the Institutional Repository of the University of Leiden](#)

Downloaded from: <https://hdl.handle.net/1887/4862>

Note: To cite this publication please use the final published version (if applicable).

Inner aspect and telicity

The decompositional and the quantificational nature of
eventualities at the syntax-semantics interface

Published by
LOT
Janskerkhof 13
3512 BL Utrecht
The Netherlands

phone: +31 30 253 6006
fax: +31 30 253 6000
e-mail: lot@let.uu.nl
<http://www.lot.let.uu.nl/>

ISBN-10: 90-78328-13-4
ISBN-13: 978-90-78328-13-1

NUR 632

Copyright © 2006: Boban Artsenijević. All rights reserved.

Inner aspect and telicity
The decompositional and the quantificational nature of
eventualities at the syntax-semantics interface

PROEFSCHRIFT

ter verkrijging van
de graad van Doctor aan de Universiteit Leiden,
op gezag van de Rector Magnificus Dr. D.D. Breimer,
hoogleraar in de faculteit der Wiskunde en
Natuurwetenschappen en die der Geneeskunde,
volgens besluit van het College voor Promoties
te verdedigen op woensdag 11 oktober 2006
klokke 15:00 uur

door

Boban Arsenijević

geboren te Niš, Serbia

in 1974

Promotiecommissie:

Promotor: Prof. dr. G. A. M. Kempen

Co-promotor: Dr. C. L. J. M. Cremers

Referent: Prof. dr. A. G. B. ter Meulen (Rijksuniversiteit Groningen)

Overige leden: Dr. R. Bhatt (The University of Massachusetts at Amherst)

Prof. dr. L. L. S. Cheng

Prof. dr. H. J. Verkuyl (Universiteit Utrecht)

TABLE OF CONTENTS

Acknowledgements	ix
Chapter I: Introduction	1
Aim of the dissertation	1
Eventualities	1
Eventualities and decomposition	3
1.1. Introduction: eventualities	3
1.2. The linking problem: from syntax to concepts	4
1.3. General properties of the structure	10
1.4. Terminology	12
1.5. Summary	13
An overview of the dissertation	13
Chapter II: Four theories of eventualities and aspect	17
1. Introduction	17
Inner aspect	18
1.1. Introduction	18
1.2. Vendler's classes	23
1.3. Summary	25
Verkuyl on aspectual composition	25
1.4. Introduction	25
1.5. The composition of aspect	26
1.6. Remarks on Verkuyl's two types of dynamic verbs	30
1.7. Negation lexicalized on arguments and its effects on telicity	33
1.8. Summary	36
Mereological tools for aspect	36
1.9. Introduction	36
1.10. The global picture: verbs, thematic roles, types of reference	38
1.11. Quantization and cumulativity	40
1.12. Divisiveness and the parallel between reference types and entailment	43
1.13. How many reference types?	45
1.14. Complex quantifiers	49
1.15. Paths, Sources and Goals	52
1.16. Summary	55
A syntactic approach to eventualities: Borer (2005b)	57
1.17. Introduction	57
1.18. To eventualities through syntax	58
1.19. Telicity as non-homogeneity: advantages and problems	66
1.20. Some problems and debatable aspects of Borer's approach	71
1.21. Assignment, distribution, quantification	77
1.22. Summary	78
Syntax of decomposition: Ramchand (2002)	80
1.23. Introduction	80
1.24. The tripartite decomposition	81
1.25. Two reasons for dropping the process subevent	86
1.26. Traveling light: without the process subevent	89
1.27. Summary	90
Conclusion	91

TABLE OF CONTENTS

Chapter III: Eventualities at the syntax-semantics interface	97
1. Introduction	97
Refining the model	98
1.1. Introduction: the model presented in the preceding chapters	98
1.2. Concatenation plus [ADD TO]	103
1.3. Summary	110
Quantificational aspects	111
1.4. Introduction: inner aspect and core telicity	111
1.5. Nonspecific arguments in telic eventualities	113
1.6. Correlations between inner aspect and the arguments of an eventuality	116
1.7. Mereological relations	122
1.8. More on quantification	125
1.9. Mass participants in non-mass eventualities?	133
1.10. Mass Undergoers in Serbo-Croatian	134
1.11. Consequences for bare plurals	140
1.12. Summary	142
Possible points of criticism	144
1.13. A note on the reflexes of the QP on nonspecific participants	144
1.14. Singular and bare plural as the default interpretations	149
1.15. Summary	151
Concluding and evaluating remarks	151
Chapter IV: Eventualities as arguments with temporal reference	153
1. Introduction	153
Matters of time	153
1.1. Introduction	153
1.2. The nature of the <i>for</i> -phrase	154
1.3. <i>For</i> -phrase and the temporal structure of the eventuality	159
1.4. The position of the <i>for</i> -phrase	165
1.5. The meaning and effects of the <i>in</i> -phrase	170
1.6. The temporal nature of states	174
1.7. Summary	179
Eventualities as arguments	180
1.8. Introduction	180
1.9. Arguments and argumenthood	181
1.10. The progressive	184
1.11. The imperfective paradox	189
1.12. The perfect and the causative	192
1.13. Summary	198
Conclusion	198
Chapter V: Serbo-Croatian verb-affixes	201
1. Introduction	201
S-C affixes in the telic template	203
1.1. Arguments of the prefixes	203
1.2. The imperfective suffix	208
1.3. External (or superlexical) prefixes	210
1.4. The semelfactive suffix	215
Conclusion	220

TABLE OF CONTENTS

Chapter VI: Conclusions and perspectives	221
1. Overview	221
Conclusions	224
1.1. Theoretical conclusions about the VP	224
1.2. Empirical aspects	225
Perspectives	225
References	227
Samenvatting in het Nederlands (Summary in Dutch)	233
Curriculum Vitae	240

Acknowledgements

This dissertation would not have been written, and I would not have spent four beautiful years at the Leiden University, without the matrioshkas of the Spreekbuis, I²RP and ToKeN2000 projects, all funded by NWO (the Dutch Organization for Scientific Research). I am very grateful for that, and I thank all the people who took part in these projects, or provided logistic help, especially Stefano Bocconi, Lynda Hardman, Christiane Klöditz, Lambert Schomaker and Floris Wiesman. Above all, I want to thank the two persons who hired me for the project, and then stood beside me during the whole period, and on each level: from the participation in the project, through developing my ideas and learning to present them, to my private life. They always had a lot of genuine interest, and understanding – when I needed it, for my work and for my life. They spent time contemplating my ideas, both those with some possible future and the hopeless ones, always coming back with inspiring comments. Knowing them made my life richer and my faith in science and mankind much stronger.

My thanks also go to the Leiden University Funds (LUF), for the grant they awarded me and with which I first came to Leiden for a year of advanced master's studies. During this stay I met the people who inspired me to stay in Leiden and brought to my attention the project thanks to which I could do so.

I would like to thank everyone at the Leiden University Centre for Linguistics (LUCL, former ULCL), for their help from the day I arrived till the last day of my stay in Leiden. In particular, I want to thank Jeroen van de Weijer, for being a wonderful coordinator and a real friend. After my arrival, and before I got my first Leiden accommodation, I felt at home at Jeroen and Grażyna's house. When I tried to thank them, they said that there is nothing to thank for, because I will be doing the same for others. I will, with great satisfaction, but still: thanks. I also want to thank José Birker, without whose efficient and human involvement, my family and I probably would still be waiting for the Dutch visa, and to Gea Hakker, who took care that the practical matters at the institute always looked like a nice break from the linguistic work. I am grateful to Vincent van Heuven: without his letters, from those approving finances, to those confirming to the IND that a researcher indeed needs to travel abroad once in a while, this dissertation, but also I as a person, would lack some crucial ingredients.

I believe I gained more linguistic knowledge through oral communication than from all the papers and books that I read. Special thanks in this respect go to Lisa Cheng and Jeroen van de Weijer, who invested a lot of energy in keeping reading groups, seminars, guest lectures and other events going on with high intensity. None of these events could contribute to the present dissertation as much as they did without my colleagues at the institute. For all this, and especially for a plenty of enlightening discussions, I thank all the linguists of LUCL, in particular: Leston Buell, Lisa Cheng, Liesbeth de Clerck, Jeroen van Craenenbruck, Jenny Doetjes, Nouredine Elouazizi, Veronique van Gelderen, Stella Grillia, Marjo van Koppen, František

Kratochvil, Nancy Kula, Frank Landsbergen, Anikó Lipták, Mika Pos, Hilke Reckman, Chris Reintges, Kristina Riedel, Johan Roorick, Martin Salzmann, Erik Schoorlemmer, Joanna Sio, Rint Sybesma, Olga Tomić, Rada Trnavac, Luis Vicente, Mark de Vos, Jenneke van der Wal, Leo Wong and Ton van der Wouden. I should not forget my precious discussion partners from other places, including: Klaus Abels, Enoch Aboh, David Adger, Anne Breitbarth, Jakub Dotlačil, Berit Gehrke, Nino Grillo, Jutta Hartmann, Vera Hegedus, Lutz Marten, Krzyztof Migdalski, Nataša Miličević, Tanja Miličev, Øystein Nilsen, Gillian Ramchand, Tanja Samardžić, Peter Svenonius, Hedde Zeijlstra and Eytan Zweig.

The best and worst moments of my dissertation journey have been shared with many people. The linguists among them are already mentioned above, but some I need to thank again. I thank them all for giving me their friendship, as deep and as rich as friendship can be. These are my paranymphs, František Kratochvil and Hilke Reckman. Among many other things, I thank Franti for his way of life and for the place in it that he gave to me and my family. And Hilke, for helping me to understand, and often even love, the country in which otherwise I would have stayed a foreigner after all this time. I thank Joanna Sio, for her sense of humor and for all the exciting Chinese games, from Judo to checkers. Her oriental wisdom, packed in short sentences, told me so much about the world, and about wisdom. The honesty and warmth of Nancy Kula were always there (even when Nancy herself was away), as an asylum from the distant and cold Old World's north-west. There are two types of honest people, those who confess and those who criticize; a representative of the latter, Nancy often helped me see myself more realistically. I thank Nino Grillo for keeping some Mediterranean ambience around all the time. Since it is impossible to chase him around the world, I just hope our ways will continue to cross as often as they do now. In this dissertation, I tried to be exhaustive and systematic in treating the data and the existing literature. To the extent that I managed – I learned it from Berit Gehrke, who witnessed and influenced the development of my view of aspect and event structure from its first steps to the version in this book.

I am not exaggerating, if I say that surviving the last four years would be quite a challenge for me without my non-linguistic friends. Through their friendship, Čeda and DeDe Bakkerić made me feel as protected and safe in Holland, as I felt the last time when I was five. If I ever return – it will be to a great extent in order to be close to them again. In the most difficult moments, I tried to look at things through the eyes of Dokolica and Skule KorteJufferić, who always had enough of positive spirit for a dozen people.

The last, and surely the most, I want to thank my family, for their love. I thank Lidija and Dunja for being with me, also in places that they did not really enjoy, and my parents for letting me go, not just this last time, but so many times in my life. I devote this book to them.

Chapter I: Introduction

1. Aim of the dissertation¹

The aim of this dissertation is to develop a model of the Verb Phrase (VP) at the interface between syntax and semantics, which will feature the advantages of the existing ones, while at the same time reconciling their differences. The dissertation concentrates on the notion of eventualities and on problems related to argument structure, aspectual structure, and their mutual relations. Though highly theoretical, the dissertation is a result of efforts to develop an interface between a semantic database and a syntactic realizer in natural language generation (NLG) and this background reflects in some of the choices made on the theoretical level. The dissertation, however, only concentrates on the theoretical side of the problems discussed, without entering a discussion of their NLG aspects.

The dissertation forms part of a research project on computational NLG primarily for Dutch, but also for English. Therefore, most of my examples are from these two languages. Where Dutch and English behave (nearly) the same, I present examples from English, for reasons of accessibility. However, the model that I propose, as well as the already existing ones that I present and discuss, aims at a universal theoretical model for the phenomena treated. To illustrate the applicability of the model outside the Germanic group of languages, I sometimes introduce the Slavic paradigm, which is quite different and more explicit in realizing aspect (through prefixes) and elements of argument structure (through morphological case-endings).

2. Eventualities

Grammar interacts with many other domains, or capacities, of the human mind. Some of these capacities are also part of language, like many of the issues attributed to pragmatics. There are two very prominent interfaces of grammar with non-linguistic domains. The first links it to the psycho-motor capacities, which are engaged in embodying linguistic units into physical carriers. The second is the link with conceptual representations, and it relates grammar with our aggregate knowledge of the world, including the material experience, different feelings, sensations and abstract notions. The latter interface is linked to grammar through the lexicon, which associates lexical units with conceptual content, and through semantics, which, among other things, places conceptual units into larger linguistic structures and establishes relations between them. The domain of semantics most directly engaged with this interface concerns the meaning of the VP. The semantics of the VP and its relation with syntax is the central topic of this dissertation.

The meaning of the VP most often realizes predicates that have a relatively rich conceptual content and do not bear a lot of syntactically active material. Usually, within the VP, a certain predicate is associated with a number of arguments. An important property of this predicate appears to be whether it describes a certain

¹ The dissertation was carried out in the context of the Spreekbuis project, which is a subproject of the I²RP (Intelligent Information Retrieval and Presentation) project, as well as of the ToKeN2000 (Accessibility and Knowledge Retrieval in the Netherlands 2000) project, all funded by NWO ‘Netherlands Organization for Scientific Research’.

process, and whether this process is characterized by a certain stage that determines its end. This stage is referred to by different terms: the culmination, the termination, the telos, etc. and predicates involving such a stage are usually called culminating, terminating or telic processes. Involving a process, or both a process and a telic point, makes the meaning of the VP correspond to a real world phenomenon that we can describe as an event. If none of these two components are involved, the meaning of a VP describes a state. For this reason, many linguists use the terms *events* and *states* to refer to the corresponding types of meanings of the VP. A third term, *eventualities*, is introduced by Bach (1986) to cover both (or all in some more fine-grained division) types of meanings of the VP. While the terms *eventuality* and *state* are quite uniformly used, the term *event* is generally used in one of three possible ways: to cover all three mentioned types of predicates states (i.e. as a synonym of the term *eventuality*), to denote a predicate that involves a process irrespective of the telic point, or to denote a predicate that involves both a process and a telic point. This very much degrades the usability of the term and therefore I will try to avoid it. The other constituents of the VP that are integrated in its meaning are called event participants, and the way in which they participate is referred to by the term *participant roles*, or *thematic roles*. The last frequently used term that I introduce here is *event structure*. Originally, this term referred only to one type of approach to the meaning of the VP, related to the seminal work of Davidson (1967). Approaches of this type all involve semantic decomposition of eventualities, in particular with respect to the roles that different participants may have in it, and represent the eventuality itself as yet another argument of the VP predicate. For a detailed introduction to the presented notions see e.g. Parsons (1990).

In the dissertation, I use decomposition of eventualities to also decompose most of these notions or in some cases to reduce their complexity. I propose a model of decomposition of VP at the syntax-semantics interface in which argument structure, aspect and conceptual interpretational properties related to event structure are derived from primitive predicates and the structural representation in which they appear. Dynamicity that characterizes processes is represented by a particular function that maps from times to properties, and telicity is represented as a result of concatenation of one process and one state, under a few additional conditions. Thematic roles are fully dispensed with, and replaced by basic structural relations in combination with primitive predicates appearing in the relevant heads. The general notion of argumenthood is derived through the predicates of division, concatenation and quantification, so that the effects provided by the Davidsonian theory are achieved without having to introduce an additional basic type: the event argument.

From the formal point of view, the meaning of the VP has many different dimensions, but the two most interesting ones appear to be those related to temporal structure and argument structure. The VP is the starting point in determining the temporal structure of the clause, since it appears to have a reduced compatibility with different temporal patterns established in other domains. Problems related to this domain are explored within the theory of aspect. The meaning of VP also incorporates a number of other constituents, which have their own denotations, and it assigns them particular roles in its aggregate interpretation. This domain is usually referred to as the argument structure. The domains of aspect and argument structure appear to be related, or possibly even to represent two instances of the same pheno-

menon. At the same time, they are connected to other phenomena within and outside of language, which brings a certain amount of noise into the picture of their relation.

3. Eventualities and decomposition

3.1. Introduction: eventualities

In this section, I introduce the notions that are central to the entire dissertation: the notion of eventuality and its decomposition, as well as VPs, events, states, participants, structural arguments, argument structure and aspect; some central points of the relations between these notions are presented, and the ground is prepared for several approaches to the observed problems of particular relevance to this dissertation. The aim of this section is not to introduce the model that I propose and argue for in this dissertation, but rather to introduce the reader into the most important problems in the field, playing a little bit with the problems, their possible solutions, and the inventory of notions and structures that they use.

Most theories of grammar over the last two centuries have recognized three different domains in the syntactic and semantic structure of a sentence. The first is related to context and discourse. The second domain is concerned with reference, quantification, tense, clausal subjects and other similar elements usually lexicalized through auxiliaries, inflection and determiners. The third domain relates to the conceptual content of sentential meaning, the verb, its arguments and their relations, as well as the corresponding material in the nominal expressions. The latter two domains reduce to only one in Chapters III and IV of this dissertation, where some of the core conceptual properties of eventualities are assigned functional projections.

Consider the sentence in (1a). Its meaning involves three participants, referred to as *John*, *a bag* and *the closet*. The meaning of (1a) creates a relation between these three participants: John performs an action with respect to a bag, and as a result of this action the bag ends up in the closet. This aspect of the meaning is to a certain extent contributed by the lexical meaning of the verb (*put*). Other contributions may come, among other possible sources, from prepositions (*into*), meanings associated with the participants of the eventuality, or possible morphological case-endings. For the full set of relations of this type taking part in the meaning of a single sentence, semantics uses the term *eventuality*.

- (1) a. John put a bag into the closet.
b. Mary slept.

The sentence in (1b) also introduces an eventuality: there is a certain state, involving conceptual content such as having one's eyes closed, suspended consciousness, possibly related to dreams etc., and an entity referred to as *Mary*, which is in this state. And this is the case for every well-formed sentence in language: every sentence has an eventuality as one of its major semantic ingredients.²

² One may question this generalization. For instance sentences expressing generic assertions or even just individual level predicates ('Lions have manes'), may be argued not to involve any eventuality. I think, however, that these sentences all do involve (usually stative) eventualities, and that the relevant effects come from the properties of quantification over these eventualities and the reference time to which they are related. I do not discuss this question any further as it is not central for the topic of the dissertation.

There is no doubt that eventualities are meanings; furthermore, they are parts of sentential meanings, so they are a part of semantics. Moreover, the variety of participant roles described above that they involve suggests that they are complex structures. Interesting questions concern the complexity level of eventualities, their contents, and whether this information is supposed to come from the lexical meaning of the verb or is represented in the domains of semantics and/or syntax.

A set of important properties of eventualities, such as involving a process or a state, involving culmination (or phase transition), entailing only that an eventuality has started, or that it was completed etc. is covered by the term *aspect*. I return to aspect in the beginning of Chapter II, while this section grants more attention to the argument structure.

3.2. The linking problem: from syntax to concepts

In order to be properly interpreted, eventualities require a representation of the manner of participation of their participants. Some participants are lexically specified, such as *into the closet* in (1a), where *in* marks that the participant introduced is some kind of location. Lexical specification of the way of participation can appear in a variety of forms, from adpositions to morphological case-endings. Sometimes, however, participants appear without any lexical specification for their way of participation, like *John* and *a bag* in the English sentence in (1a). This way of realizing participants is referred to as the *structural arguments* of the VP. How do we know in (1a) that it is John who acts in a certain way and that it is the bag that changes location and ends up in the closet? This question lies at the core of what is usually referred to as the *linking problem*, the problem of linking participants with the way they participate in the eventuality.³ Elements of the conceptual representation contributed by the meaning of the verb have to be associated with denotations of usually nominal expressions introducing participants. It sounds reasonable that this linking is determined by our knowledge of the world: John refers to a human, a bag is an object and humans are more likely to carry objects than objects are to carry humans. But the problem is not as simple as this. For instance, (2a) can never mean the same as (1), although it has the same verb and participants. In spite of the clear pragmatic knowledge that it is natural that John moves the bag, that the bag moves, and that the closet is a location, the sentence in (2a) can only mean that a bag is acting and the closet is moving, to end up inside John.⁴ Furthermore, the sentences in (2b-c) are at the very least pragmatically odd. In some languages, sentences like (2b) are quite normal when interpreted with very general or strongly contextually suggested objects, as illustrated with the Serbo-Croatian example in (2g). The sentence in (2c), just like (2a), is improved if the closet is personified (the closet wanted a bag and John brought *him/her* one). Even some English verbs, as in (2e), can be used elliptically. Although eating necessarily involves something that is eaten, the sentence is grammatical and has either the interpretation that John ate food, or the meal typical of the hour at which the eating happened. Though it is directly or indirectly involved, pragmatic knowledge is neither sufficient nor the most important factor in determining participant roles.

³ The term *linking problem* is to my knowledge first used in Carter (1976).

⁴ This argument is from Borer (2005b), though here used somewhat differently.

- (2) a. (#)A bag put the closet into John.
 b. #/?John put.
 c. #/?John brought the closet a bag.
 d. John brought Mary a bag.
 e. John ate.
 f. John yawned.
 g. Jovan je u-bacio.
 Jovan AUX in-throw
 ‘Jovan put something/the relevant object in.’

One important remark is due before proceeding. In (2), I use a dash (#) to mark the sentence for pragmatic unacceptability or uninterpretability and a question mark (?) for a sentence with degraded grammaticality. I will also be using an asterisk (*) for ungrammatical sentences, i.e. sentences which are bad for grammatical reasons. This marking is language specific: it relates to the particular sentence in a particular language. There are many cases where it is unclear, or theory-dependent, whether a sentence is less acceptable for reasons of grammaticality or for pragmatic and semantic matters. In such cases, if the example is cited from the literature or forms part of the discussion of some other work, I preserve the marking that the sentence has in the source to which it relates. In other cases, I use marking according to my own theoretical views. Finally, I sometimes leave the decision open and use two marks as alternatives, or add an explicit comment to explain the marking.

To return to the topic under discussion, a solution involving a hierarchy of participant roles seems more appropriate than relying on the knowledge of the world in order to link the arguments of a sentence with the participants in an eventuality. One position in this hierarchy is assigned to the participant who carries out an action and another one to the participant that undergoes it. The hierarchy also involves other participants, such as the location at which something ends up (the Goal), the trace of some movement (Path), and others. In addition to this, to account for the ungrammaticality of (2b-c) and the grammaticality of (2d-f), a list of participant roles has to be supplied for each particular verb, specifying the number of participants it takes, the way in which each of them participates in the eventuality, and which of them are obligatory. This obviously depends on having a functional and precisely defined set of participant roles. At least since Gruber (1976) and Fillmore (1968), formal grammarians have considered constructing such a system one of the central tasks of linguistic research. In combination with a set of rules, this hierarchy is supposed to map the interpretational properties of participants to the structural positions (syntactic functions) in which they are syntactically represented. When considered in relation to syntactic structure, the participant roles are most often called *thematic roles*. Different authors proposed different sets of thematic roles, ranging in number from two (the proto-agent and the proto-patient in Dowty 1991 or the Actor and the Undergoer in Van Valin & Lapolla 1997) to a separate set of roles for each verb (*Runner* for *run*; *Cleaner*, *Cleaned* for *clean*; *Giver*, *Given*, *Givee* for *to give*), as in, among others, Kempen (1970) or Ahrens & Swinney (1995). Naturally, the smaller the number of roles assumed, the less conceptual content is assigned to them, and the more formal the theory based on them can be.

Empirical support for systems with a small number of different roles comes from the fact that (to my knowledge) there is no language in which a VP can be formed which uncontroversially has more than two structural arguments. In examples in which there seem to be three or four, it can be shown that only two are real structural arguments and the others involve a (deleted) preposition or inherent case, or are in fact predicates and not arguments. Typically, double object constructions are suggested as counterexample for this view, but as discussed in relation to (5) below, they are nicely analyzed in terms of resultative predicates.

Throughout the dissertation, especially in Chapter III, where I propose my own model, I tend to eliminate the notion of thematic roles. I use a binary branching phrase structure, where a single phrase consists of a head, filled with a syntactically primitive predicate, and a specifier and a complement, as two arguments of this predicate. The head of the phrase in which a participant is generated, in combination with the properties generally assigned to specifiers and complements, determines its way of participation. Also, on a more complex level of VP, which I treat as a structure with more than one phrase, there will be two structural arguments, i.e. two arguments that are assigned case by the very VP, without the help of prepositions or other assigners. I refer to these two arguments as the Initiator and the Undergoer, and provide precise semantic and syntactic definition in Chapter III, section 2.

Assuming that an approach along the lines of the previous paragraph can handle the linking problem, we also need to know how much of this material is truly relevant for grammar, and therefore needs to be represented in the syntactic and semantic representations of eventualities (the remainder being viewed as part of the non-linguistic, purely conceptual representation of eventualities, in the sense of Jackendoff 1990). Some aspects of the linking problem that are related to grammar become obvious in the English examples in (2): there are positions in the syntactic structure of the sentence which rigidly impose certain kinds of interpretation without any lexical marking, and which may or may not be filled, depending on the verb used in the VP. In English transitive verbs, this holds, roughly speaking, for the position immediately following the verb. The participant in this position tends to be interpreted as undergoing a certain process, if any process is entailed, or simply as the theme of some predicate. Thus, in (1a) and (2a), whichever participant appears in this position, the interpretation it receives is that of undergoing the putting. If the eventuality involves a process and two structural arguments, the participant that appears before the verb is in most cases interpreted as initiating this process, ranging from direct engagement in an action to mere causing of a certain process. In (1a) and (2a), the participant taking this position (*John* and *a bag* respectively) receives the interpretation of the one who carries out the putting. He either controls the putting without a direct causation (by making decisions which are executed by other agents), or causes it without a control over it (e.g. some property of John caused a series of eventualities which led to the bag ending up in a particular closet), or both controls it and directly causes it. I do not discuss the issue of control vs. causation; for purposes of this chapter, I assume that the distinction comes from the head of the projection in which this argument is generated, and that a number of verbs are ambiguous for whether they involve only one of the two (sub-)roles or both.

The two observed participant roles are directly determined by the structure of the VP (see Chapter III, section 2). That is why participants in these two positions are

called the structural arguments. All other participants are covered by the term *oblique participants* or *oblique arguments*. There is one more meaning assigned to this latter term, which is not exploited in this dissertation: it is associated with the optional participants, as opposed to the obligatory ones, i.e. to the participants that are conceptually required by the meaning of a certain verb. As shown in (3), not all obligatory participants are structural arguments. I will not go deeper into the question of obligatoriness of participants at this point, but for a more detailed discussion see Koenig, Mauner & Bienvenue (2003).

- (3) a. Jan ziet er *(slecht)uit. Dutch
 Jan look EXPL bad out
 ‘Jan looks like he is not healthy/happy.’
 b. Jan woont *(in Leiden).
 Jan lives in Leiden
 ‘Jan lives in Leiden’

The rigidity of interpretation of the participants that are lexically marked for the way of participation, such as the participant in (1a) marked by the preposition *into* (therefore part of a Prepositional Phrase, PP) can be attributed to the lexical marker (the preposition in the given example). Therefore, at least with respect to the linking problem, such participants are less dependent on the syntactic structure in which they appear. But this does not hold for the structural arguments, which have no marking apart from their structural embedding (they may bear a morphological nominative or accusative, but without a preposition or other similar marking it is difficult to generalize over the meaning of these case-endings). Therefore, this structural embedding has to be explicitly represented in order to set the ground for a proper linking theory (a model handling the linking problem). At this stage, this can be done by imposing a minimal structure on eventualities which is sufficient to capture the effects observed so far (two different positions for the two structural arguments). One such representation is given in (4). The general structure used in the figure is traditionally assigned the following interpretation. The higher branch, referred to as the *specifier*, introduces a complex structure, which is interpreted as the argument of the predicate formed by the two lower branches. The lower left branch is referred to as the head, and it contains structurally simple material. The lower right branch is referred to as the complement, and, like the specifier, it is also structurally complex. I will semantically treat the head as a two-place predicate taking the specifier and the complement as its arguments.

- (4) Minimal hierarchical structure for an eventuality

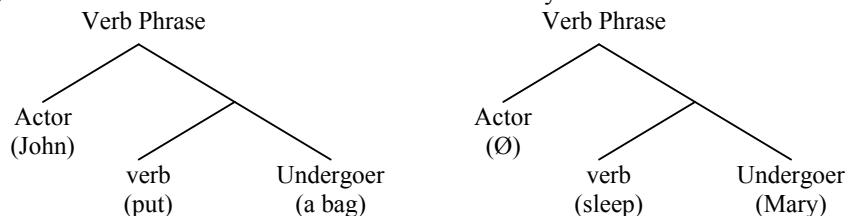

When representing a VP headed by a predicate that involves a process, the specifier of this binary branching tree introduces the participant with the ‘acting’ interpretation. The complement introduces the participant with respect to which the action takes place, while the head contains the predicate, lexicalized as the verb.⁵ In this way, the two structural arguments are distinguished by being on different levels in a hierarchical structure. The lower argument builds a complex predicate with the head, and this complex predicate takes the specifier as its subject.

A general question that needs to be answered at this point concerns the module of grammar where this structure is represented and how it is selected and combined with the lexical material. Two types of answers have been proposed in the literature. One is that every verb is stored in the lexicon together with the structure it appears in. The other is that there is no structure in the lexicon, but only in the module of syntax, and that any lexical material can be attached to the positions it makes available. I will remain agnostic with respect to this question until Chapter III, section 2.2, where I formulate an explicit answer. In both cases, however, the eventuality is broken down into smaller units: those related to a particular way of participation of at least some of the participants and those related to the way these participations are combined. The term used for this type of analysis is *decomposition*: eventualities are decomposed into the smaller units from which they are built.

One question still remains open: is this structure sufficient for all the phenomena in language that are related to eventualities? A way to show it is not is to find counterexamples to the thesis that verbs tend to take at most or exactly two structural arguments.

One such case is the double object construction, as in (5a), in which the eventuality seems to have three different structural arguments, two of which have the properties assigned to the argument that normally in English appears after the verb. These two participants still have significantly different interpretations, which both resist any coercion based on pragmatic knowledge. Consider (5b). Although it is much more ‘normal’ that the letter is sent and that Mary receives it, this interpretation is not available for the sentence. The only one that there is would have Mary sent to a letter. Still, a number of explanations can be put forward to eliminate this problem for the two-argument thesis. For instance, double object constructions are similar to those involving resultatives as in (5c). One of the apparent objects can thus be seen as a kind of a predicate, and therefore not a real argument.⁶

- (5) a. John sent Mary a letter.
 b. #John sent a letter Mary.
 c. John painted Mary red.

⁵ The terms Actor and Undergoer are borrowed from Van Valin & Lapolla (1997), although not with the exact inventory of characteristics that they assign to them, but instead I use them as bare labels that only represent an asymmetry. Their nature is discussed in Chapter III. Descriptively, active participation relates to the part of the eventuality that initiates or drives a certain process (in (1), John drives a certain process which results in the bag being in the closet), and may further involve control over the process.

⁶ See Snyder 2001 for an analysis along these lines and some convincing arguments in its favor. Another way out is Larson’s (1988) VP shells analysis, which presents all ditransitive verbs as structures built by using two-argument predicates as building blocks.

Some other examples in favor of expanding the structure in (4) are not so easily put aside. Such is the case with the following effect, discussed in Hale and Keyser (1993). Observe the VP in (6a, b), where the meaning of the verb seems to include not only relations between the participants of the eventuality, but also the meaning that relates to one of the participants in the eventuality.

- (6) a. John saddled the horse.⁷
 ‘John put the saddle on the horse.’
 b. John shelved the books.
 ‘John put the books on the shelf.’
 c. Simple VP structure d. Expanded VP structure

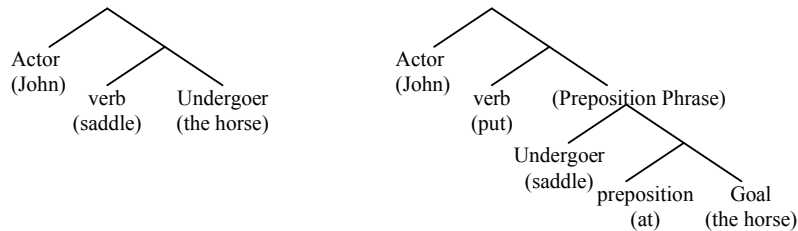

Let us assume that this observation is correct and that the verb really somehow incorporates one of the participants, being a lexical realization not only of the head, but of the head together with a part of the complement. The structure in (6d) is based on the assumption that a part of the structural argument is incorporated. This leaves the part that did not undergo incorporation without a lexical specification of its way of participation (i.e. the predicate corresponding to the prepositional meaning is incorporated). In the sentence, this participant surfaces as one of the structural arguments: the direct object.

The problem with keeping the simple structure, as in (6c), is that it forces us to claim that putting a saddle on the horse and saddling the horse are two completely different eventualities from the point of view of their grammatical structure. Expanding the structure of the VP allows us to see saddling a horse as just a special, syntactically and lexically licensed, realization of the same underlying representation. This is illustrated in (6d), which is just one possible way of expanding the VP for the given type of construction (different from the one proposed in Hale and Keyser 1993). This structure expands the bottom of the structure, more precisely the node where the Undergoer was derived. The position of the Undergoer from (6c) is filled in (6d) with a complex structure representing a predication (in this case a PP), and the Undergoer is now lower, in the specifier of the PP. The bottom of the structure contains the predicate of the PP and its other argument, interpreted as the Goal.

Let us consider the structure in (6d) and see what interpretation is derived. Starting from the top, we find a certain participant John, who participates in an acting way with respect to a certain predication. This predication is represented as a PP, which specifies that a saddle is on the horse. Since no temporal or causal relation is

⁷ It is debatable here what is the underlying structure of this sentence. In order to explicitly capture the spatial relations, I choose to represent it as placing the saddle on the horse. Alternatively, it can be represented as providing the horse with a saddle.

specified in the representation, the predications are interpreted as simultaneous: John acts with respect to the saddle on the horse. This is not the interpretation of the sentence in (6a). The missing ingredient is the result interpretation of the PP (the saddle being on the horse). Without this ingredient, the structure has the interpretation that John acts in a putting manner and somehow affects a saddle which is already on the horse, instead of affecting it so that it ends up on the horse.

We can save the structure by stipulating that the position where the PP is attached involves the notion of a *result*. In such a structure, the Actor and the meaning contributed by the verb are related to the result, but they do not belong to it. The most directly available interpretation for this part of the structure is thus that it initiates the result. Since results can be initiated without a (controlled) action, as shown in (7), I will for the moment use the term ‘Initiator’ (borrowed from Ramchand 2002) instead of the term ‘Actor’ to mark this way of participation.

(7) The wind shelved the books.

This leads to a re-labeling of the structure in (6d) as in (8). This step brings in one additional stipulated notion to the model: the notion of result. In fact, however, it is possible to derive not only the notion of result, but also the other particular roles from this structure by stipulating only one predicate.

(8) Complex structure for (1a)

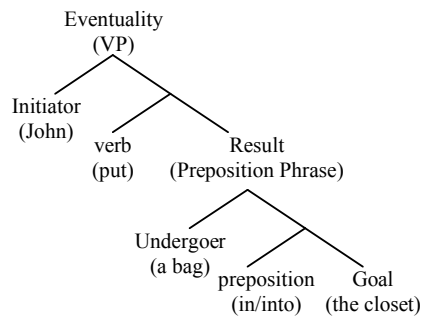

Let us first go back to (1a). Clearly, the structure in (6d) should apply here as well, since the eventualities are of the same type. The structure of (1a) would then be as in (8), where the revised labeling is applied. John acts in a putting manner and this initiates the result of a bag being in the closet. The structure we ended up with, together with the three central arguments (Initiator, Undergoer and Result), is a variation on the structure proposed in Ramchand (2002), presented in more detail in Chapter II, section 6. At the same time, the structure in (8) is halfway towards the model argued for in this thesis, which is presented in Chapter III.

3.3. General properties of the structure

The structure in (8) is reminiscent of a number of accounts that have been proposed in the literature. This structure is a simple hybrid variant of well known proposals such as the ones of Larson (1988), Hale and Keyser (1993) or Svenonius (1996). After a number of additional adjustments, it is used in this thesis as a neutral structure, i.e. as a background against which other proposals and approaches are

discussed. In Chapter III, it is further refined to arrive to a new model which is the central contribution of this dissertation. The structure in (8) so far involves four different labels without precise definitions: Initiator, Result, Undergoer and Goal. All four of them are interpretive properties of respective nodes in the structure. One simple move lets us derive them all from the properties of the phrase structure that is used to represent them. The move is to postulate a predicate that represents the initiating relation between the node immediately above (that with the the NP *John*) and the structure below the verb (the phrase with the predication *a bag in the closet*).

The predicate that represents this initiating relation should not entail any control of its subject (here *John*), in order to cover sentences in which the volitional control is not entailed (like the wind shelving books in (7)). I will mark this predicate as *lead_to*. This predicate associates two semantic units if a certain property of one of them (an action, process or state) is universally able to initiate or even just condition the other. Now we can add this predicate to the head position where we used to place the verb, as in (9). The same head also contains other predicates that are a part of the lexical meaning of the verb, just as those in the head of the result state, which are marked as result predicates.

(9) Generalized expanded structure of VP

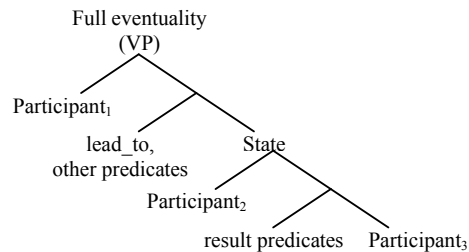

The lower structure is no longer stipulated as the result – it is a bare one- or two-place predicate (a state or a process). Its result interpretation comes from the predicate *lead_to* in the higher head. The same holds for the subject of the lower section (the state) – it is the Undergoer by virtue of belonging to the result. The result specifies a newly established value for a certain property of the Undergoer. This participant thus appears as the subject of the result predication. The aggregate interpretation is that it undergoes a change that leads to the state represented in the result subevent. The Goal represents the (argument of the) value of the result predicate, i.e. the value it changes to. Finally, the Initiator is the specifier of the predicate *lead_to*, i.e. the subject of the initiating of change. Other elements that appear in the node where *lead_to* is generated are primitive lexical predicates (e.g. location, color, act, contact), which build the complex predicate of this head together with the predicate *lead_to* (they can all be viewed as features of this complex predicate). The only stipulated element we are left with is the predicate *lead_to*, which is an obligatory part of the head of the hierarchically higher phrase in the structure of the VP. To some extent, it corresponds to what is traditionally referred to as causation, while at the same time bringing in the notion of a process (leading from an unspecified state to the one specified by the lower portion of the structure). Using the term *lead_to* helps us avoid the controversy associated with causation, as

well as saving the terms of causation, initiating, origination etc. for the approaches that use them in specific ways. Consequently, an eventuality that does not have the predicate *lead to* can only be interpreted as a state. In Chapter III, I reduce the predicate *lead to* to the predicate of sum. This predicate is semantically lighter, and it is independently required and defined in other domains of syntax and semantics.

The structure in (9) is still an intermediate structure, to be used for the purpose of presenting interesting problems in the domain of eventualities, as well as preparing ground for other accounts, including the one that I propose in Chapter III. The structure in (9) is based on the one in (8), but it also incorporates elements of the event-semantic views of Parsons (1990) and Pustejovsky (1995), among others.

Even though it could be refined further, the structure in (9) is able to neatly account for most general phenomena of argument structure. Apart from the illustrations above, it is also able to derive the argument structure of unaccusative and unergative eventualities. Let me first explain these two terms and then show how the structure applies to them.

VPs are traditionally divided into transitive and intransitive ones. A transitive VP has both a subject and a direct object, as in (10a). An intransitive VP surfaces only with the subject (or more generally with only one structural argument), as in (10b-c).

- (10) a. John kissed Mary.
 b. John ran.
 c. The ice melted.

Ever since the formulation of the Unaccusative Hypothesis (Perlmutter 1978), intransitive VPs are further divided into the unergative and the unaccusative ones. Unergative VPs are those in which the only overtly represented participant corresponds to what I have been calling the Initiator, as in (10b). Unaccusative VPs surface only with what I have referred to as the Undergoer, as in (10c).

3.4. Terminology

In this section I introduced some notions and terminology that are central for the problems of event semantics and the syntax of the VP. Among them are standard terms, such as event(uality) decomposition, argument structure, participant roles and aspect. Probably the most central term, the term *event*, has been avoided in this section, because it has been assigned many different interpretations and uses, which often leads to confusion. For the most general meaning of this term, I used the more precise term *eventuality*, for which I use more explicit and more terms, such as eventualities that involve a process (all types except states) or bounded/telic eventualities (also referred to as accomplishments and achievements). Another ambiguous term that I avoid is *aktionsart*. Though it often refers to what I call here inner aspect, it is equally often used in relation to perfectivity and other outer aspect phenomena. Finally, I use very frequently the term *predicate*. I assume that predicates, as a semantic notion, correspond to two different kinds of syntactic elements: semantic contents of terminals, referred to as heads, and interpretations of complex structures. Viewed from the syntactic perspective, predicates corresponding to the material in syntactic heads are atomic. Predicates corresponding to projections are complex and compositionally derived.

3.5. Summary

This section offered a general review of the notion of (linguistic) eventualities, starting from very simple cases and gradually introducing the interesting topics in this domain: the argument and/or participant structure, and inner aspect. Finally, I introduced a constituent structure for the VP at the syntax-semantics interface. This structure represents both the syntactic and the semantic properties of eventualities.

4. An overview of the dissertation

The dissertation is organized as follows.

Chapter I provides introductory information on eventualities, the notions of aspect and argument structure and the classification of eventualities. It contains a structural representation of eventualities that can serve as a neutral model until Chapter III, where I propose and argue for a better model.

Chapter II offers an overview of four theories of event structure that constitute the important background for the structure proposed here, all focusing on the relation between the two major properties of an eventuality: aspect and argument structure.

The first one is the approach of Verkuyl (1972, 1993), which offers the earliest formal account of the relation between the arguments of an eventuality and the properties of the eventuality itself (in particular its aspect). Verkuyl's approach is compositional and does not assign eventualities a separate semantic type. He captures the relevant relations by means of a system consisting of two features, in combination giving a third. The features used as building blocks are related to the lexical meaning of the verb and to the quantificational properties of the arguments. I provide a discussion of some aspects of this approach and point to some of the problems it runs into.

Secondly, the semantic approach of Krifka (1992, 1998) is presented, in which the domain of relevant relations and participants is expanded. Krifka proposes several tactics to deal with these relations, the central one consisting of mapping between the mereological properties of the participants and the mereological properties of the eventuality, similar to the approach proposed by Verkuyl. Krifka treats eventualities as a separate basic type. An argument of this type is taken by the verb and assigned the meaning of the entire predicate formed around the meaning of the verb. His approach is nevertheless, to a high degree, decompositional. A discussion is included of some of the central points of this approach.

The third approach presented is Borer (2005b). It takes syntax to be the locus of all relations in grammar that are relevant for either aspect or argument structure. Borer introduces a syntactic projection responsible for aspect and argues that it is of the same kind as the quantifiers that appear in the nominal expression. Thus, if an argument has a quantifier, or bears the relevant property by some other means, it will assign this property to the head of the projection of aspect. This is quite similar to Krifka's mapping except that it is strongly syntactically constrained. Borer also views eventualities as a basic type, but she excludes any traditional form of decomposition. The section ends with a critical discussion of her model.

The final approach that I present in Chapter II is Ramchand (2002). Ramchand's approach is primarily syntactic, but she still reserves an important role for the semantics of eventualities. Her model is highly decompositional, and she derives

both argument structure and aspectual properties from this decomposition. Ramchand's decomposition does not require a separate basic type for eventualities. It does not involve any mapping or range assignment: quantificational effects are seen as a consequence of the relations that are established between quantifiers, such as distributivity. Via a discussion of Ramchand's model, I return to the structural representation that I proposed in Chapter I.

Chapter III presents a new model of eventualities at the interface between syntax and semantics, introducing some significant differences in 'cutting up the pie' of aspect and argument structure. The model presented is decompositional, introduces no separate basic type for eventualities and, crucially, it directly relates decomposition and mereological properties of eventualities.

I propose refinements for the structure presented in Chapter I. While only slightly complicating the structure, this brings many advantages, which are 'cashed in' throughout the rest of the chapter and in Chapters IV and V.

Standard approaches to inner aspect can be divided to those that see it as a decompositional phenomenon and to those that take it as a matter of quantificational or mereological properties. The former consider an eventuality telic if its single instantiation involves a component usually referred to as the telic point, culmination or termination. The latter consider an expression telic if it displays certain properties related to quantification, such as boundedness or non-homogeneity. In Chapter III, I propose a model that deals with both these notions and establishes a formal relation between them. Hence, I define two different properties in the domain of aspect: the narrow telicity of an eventuality, relating to whether it involves a telic point, and the inner aspect, indicated by the standard tests of inner aspect, and relating to whether the VP has a homogeneous or a non-homogeneous meaning. These two notions are mutually related in the following way. It is shown how telicity is directly linked with defining a unit of counting for the eventuality. Further, it is argued, with Borer (2005b), that non-homogeneous meanings are in fact meanings that involve count quantification, i.e. quantification that requires that the meaning to which it applies defines a unit of counting.

I argue for the possibility of direct quantification over eventualities, and for holding this quantification responsible for standard effects of inner aspect. This move expands the structure by one more projection (the one introducing quantification). Nevertheless, the trade-off is not only advantageous in the empirical domain; it also leads to a structure that is fully parallel to the structure of the nominal phrase. I argue that composing two eventualities in a decompositional model of the type that I propose is equivalent to assigning grammatical number or adding a classifier to the NP.

In chapter IV I present a discussion of the most standard test for inner aspect: the *for-* and *in-*phrases test. I propose semantic and structural analyses for these two phrases, and discuss how eventualities and time are related. In this domain, I show that the model I present views eventualities as predicates that involve mapping of times to properties.

One important consequence of the model presented is the parallel between nominal expressions and eventualities. In particular, the fact that eventualities are independently quantified predicts that they can also appear in an argument position of some other eventuality, or predicate in general. This is indeed the case in certain

special forms of aspectual and argument structures. In the second half of Chapter IV, I propose an analysis of the progressive, perfect and causative in terms of eventualities as arguments of other eventualities.

In Chapter V, further empirical support for the model and its predictions is provided by applying the model to the aspectual system of Slavic languages, using the data from Serbo-Croatian. After presenting the main properties of this system, the model is applied step by step to its two types of prefixes (internal and external) and three different suffixes, all of which have clear effects on the inner aspect of the eventuality. The model not only captures the facts, but it also unifies the accounts for internal and external prefixes.

Throughout the dissertation, I use a limited set of examples, for two reasons. It makes it easier for the reader, since the examples and their analyses are repeated many times. I also try to choose examples that are either typical of a certain phenomenon or difficult to account for with a certain type of explanation. Since the same phenomena and similar accounts appear in different places, they are illustrated and challenged by the same examples. Finally, in cases where decompositional models are applied, the motivation for choosing certain examples is their rather transparent decomposition.

In talking about the syntactic structure of the VP, both in general terms and in terms of the proposed model, I use a simple version of X-bar phrase structure (see e.g. Jackendoff 1977). It consists of a binary branching tree, in which a phrase contains a specifier, a head and a complement, and where the head first combines with the complement and this structure then further combines with the specifier. This structure is well known to a broad linguistic audience and it is very similar to the syntactic representations used by the approaches discussed in Chapter II. The model proposed is not bound in any important way to this structural representation, and may be implemented in any other framework, as long as its structural representation captures the relevant predicative, scopal and other relevant relations.

Chapter II: Four theories of eventualities and aspect

1. Introduction

Chapter I introduced the central question that this chapter deals with: What is the relationship between arguments and argument structure on the one hand, and aspectual structure on the other? In the literature, answers to this question have typically followed two lines of reasoning. Some researchers have argued that argument structure and aspectual structure are related through the quantificational properties of arguments and the relations they establish with eventuality (e.g. Verkuyl 1972, Tenny 1994). Others have argued that the relation between argument structure and aspect lies in the composition of the eventuality and the possible patterns it chooses from (e.g. Parsons 1990, Ramchand 2002). Most approaches in fact combine the two strategies, differing in the degree of prominence they grant to one or the other.

This chapter presents four different answers to the above question. The approaches I have chosen to present are certainly not exhaustive, nor are they even particularly representative of the work in the field in the last 50 years. They have primarily been chosen for their ability to introduce the phenomena, views and strategies which are important for the account I present in Chapter III.

The chapter is organized as follows. Section 2 is a general introduction to the notion of inner aspect, and it gives an overview of Vendler's (1957) aspectual classes. In section 3, I present the dependency between how a VP passes the telicity tests and the properties of its arguments and its lexical verb. The relevant phenomena are presented in the light of the earliest formal attempt to deal with them (Verkuyl 1972) as well as later work by the same author (Verkuyl 1993). This overview of Verkuyl's account is followed by the discussion of a number of technical and conceptual points relevant for the rest of this chapter, as well as for Chapter III. Section 4 offers an overview of the semantic theory of Krifka (1992, 1998), which captures the correlations between nominal expressions (realizing arguments) and the VP in terms of part-whole relations. Krifka bases his account on mereological properties of predicates, among which most importantly on cumulativity (predicate preservation under sum) and quantizedness (the predicate of the whole does not hold for any of its parts). The major goal of the section on Krifka's account is to present the potential of a mereological approach to nicely capture and mutually relate different phenomena involved in aspectual and argument structure. The properties central for Krifka, with the addition of divisiveness (every part of the whole and every difference between the whole and the part satisfy the predicate satisfied by the whole) and homogeneity (divisiveness + cumulativity) are also used in the theory of Borer (2005b), presented in section 5. Borer proposes a heavily syntactic account of VP aspect, in particular of the relation between the eventuality and its participants. In her view, the semantic properties of predicates in Krifka's theory function as formal syntactic features. I discuss some aspects of the proposal which indicate that the radical rejection of semantic decomposition leads to a number of problems. Section 6 presents the model of the syntax-semantics interface of the VP developed by Ramchand (2002). This model also relies on syntax, while still acknowledging the role played by decompositional semantics.

Having presented the advantages of an account that uses both syntactic and semantic tools in exploring inner aspect, I argue that this model must be simplified, allowing it to provide a better account for the data while avoiding a number of problems. I finally show that after some reductions and slight changes, we can get from Ramchand's model to the one presented in Chapter I. Section 7 summarizes and introduces the questions that open Chapter III.

2. Inner aspect

2.1. Introduction

The expanded decompositional structure of the VP, introduced in (9) above, is primarily supported by the measurement of the duration eventualities and other related effects covered by the notion of aspect (Vendler 1957, Verkuyl 1972, ter Meulen 1995), which was only superficially introduced in Chapter I. Let us go back to the sentences in (1), repeated in (11), and try to assign the eventualities they describe a measure of time. The type of temporal modification in (11) is one of the tests for identifying the aspectual properties of an eventuality; three other tests will be introduced later in this section. For all examples related to aspect in this chapter, I restrict myself, as it is traditionally done in the field, only to the non-iterative meanings of the given sentences (only one instance of each eventuality). If iterative meanings are to be considered, this is explicitly marked.

- (11) a. John put a bag into the closet in a minute/?for a minute.
 b. Mary slept for an hour/?in an hour.

The sentence in (11a) sounds a little odd if combined with a *for*-phrase, while it is perfect with an *in*-phrase. With the *for*-phrase, given the right context, it is possible to get the irrelevant interpretation that an hour is a measure of how long the bag stayed in the closet (as in 'John went to London for three days' or in 'John opened the window for five minutes'). However, the meaning where the putting takes an hour is completely out. On the other hand, with the *in*-phrase, it is precisely the putting of the bag that is measured.

If we now switch to the example in (11b), we see the opposite pattern: measuring the eventuality with the *for*-phrase is perfect, while the *in*-phrase sounds quite bad. There are two possible interpretations that can be enforced for the version of (11b) with an *in*-phrase. One is that at some point in the past, one hour after the reference time (which is also in the past, of course), Mary fell asleep. In this reading the *in*-phrase is not measuring the eventuality of sleeping, but the interval within which Mary fell asleep. The second reading, in which the *in*-phrase really measures the eventuality of sleeping, is judged unavailable by most speakers.

In the ideal case, aspectual effects introduced above would be derivable from properties of the structural model of the syntax-semantics interface developed for argument structure in 3.2 and 3.3. Not only would such a model have a reduced computational complexity by using one instead of two structures (i.e. one for argument structure and one for aspect), but it would also allow us to establish a direct relation between the two phenomena and at least in some cases to derive the aspectual properties of a VP from its argument structure and vice versa. In this and the next section I try to achieve this goal, still with the major purpose to highlight

the most important problems and possible strategies for solving them, as a base for the deeper analyses yet to come in this chapter and Chapter III.

Using the patterns from Chapter I, especially those from (9), combined with some labels from (8) added for clarification, the structure in (12) represents the eventuality of sleeping. The eventuality of sleeping entails no meaning of result and no process whatsoever. This feature is derived from the absence of the predicate *lead_to*, which leaves the entire upper portion of the structure empty. Consequently, the structure fails to derive the meaning of result for the lower portion. The derived meaning is a predicate of sleeping taking Mary as its subject, without any additional elements.

- (12) Structure without an Initiator or a Result⁸
‘Mary slept’

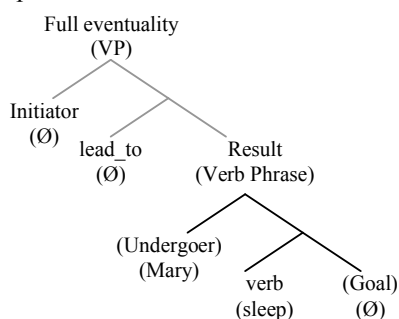

The most striking question with respect to the asymmetries presented in (11) is why in one sentence it is the *in*-phrase that measures the eventuality, while in the other it is the *for*-phrase. The only difference that we have observed so far between these two eventualities concerns their complexity (i.e. the fact that one of the two phrases building the pattern may be missing), which is related to having or lacking the predicate *lead_to*. While the structure in (11a) derives a VP with three participants (interpreted as the Initiator, the Undergoer and the Goal), the eventuality in (11b) will only need one. As long as the structure reflects relations between the participants and the eventuality, however we decide to represent an eventuality with only one participant, it will be less complex than the one with three participants. So it seems it is complexity that matters.

There are two kinds of eventualities with respect to complexity: those represented by only one phrase, and those that require a structure involving two phrases to be represented: one for the initiating part (with the Initiator and the verb) and one for the Result (with the Undergoer, the preposition and the Goal). This complexity does not plainly correspond to the number of arguments, as obvious from (13). Although it has only one participant, (13a) behaves like (11a), and although (13b) has two participants, it behaves like (11b).

- (13) a. John came in an hour/?for an hour.
b. John adored Mary for five years/?in five years

⁸ The Undergoer and the Result are in brackets because their Undergoer, i.e. Result, meanings cannot be derived without the initiating subevent.

c. Coming eventuality (telic)

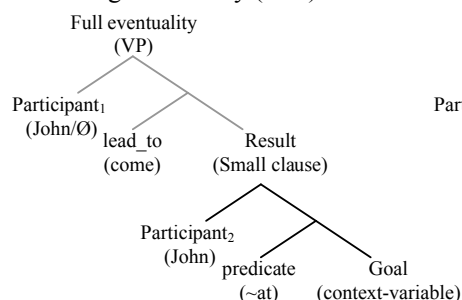

d. Adoring eventuality (atelic)

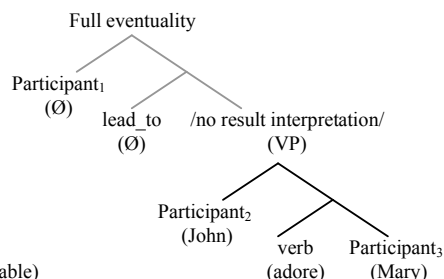

Both parts of a complex eventuality, viewed in isolation, are well-formed simple eventualities. For eventualities that appear as building blocks of other eventualities, like the Result with respect to the full VP in (13d), I will use the term *subevents*. The structure of VP used so far involves only two possible subevents: the two projections building the full VP, and only one possible complex eventuality: the full VP itself. This use of the term subevent is different from the one used by Krifka (1992, 1998), in which every part of the temporal interval of an eventuality is assigned to a part of that eventuality and this part is referred to as a subevent.

Now we can divide VPs with respect to whether or not we can see them as consisting of more than one subevent. Complex eventualities directly consist of two subevents and can only be measured by the *in*-phrase, while simple eventualities have only one subevent and are properly measured by the *for*-phrase. The sentence in (13a), despite having only one overt participant, is not based on a simple eventuality. The full eventuality that forms the VP of this sentence involves a result: its single participant ends up in a certain place, as a result of some change. This is represented in (13c), where the Goal participant is a context variable, i.e. it is determined by the context. In a context where no information is available concerning where John moves to, this sentence would be infelicitous. The sentence does not involve a separate expression introducing the Initiator. There are two interpretations available for this domain of the meaning: one is that the Initiator is unspecified (like in ‘The drink came.’), and the other that in fact the Undergoer is at the same time also the Initiator (John caused and/or controlled his change of location to the contextually specified one).⁹ The specification of one of its parts is missing in the sentence in (13b) as well, but this time it is the part related to the result and the *lead_to* predicate in its structure. The two participants, John and Mary, are both participants of the ‘lower’ subevent in the structure, as (13d) illustrates.

The tools I used to indicate asymmetries related to the complexity of eventualities deal with the temporal component of the sentential meaning. Two different patterns show different behavior with respect to two temporal adverbial phrases, involving prepositions *in* and *for*. Different tests, like those in (14), show that eventualities

⁹ It is obvious by now that I assume that the same argument can appear in more than one position in a single eventuality, and consequently also be ‘assigned more than one thematic role’. I consider this an instantiation of the so-called displacement phenomena, where one element is interpreted in two different positions in the structure.

interact with the temporal structure of the sentential meaning. The temporal structure of the meaning of a clause is complex, and involves many different dimensions. Those related to eventualities are grouped under the term *inner (or internal) aspect* (first used in Travis 1991, corresponding to the situation aspect of Smith 1991).

- (14) a. John wrote a letter in an hour/*for an hour.
 b. John wrote letters for an hour/*in an hour.
 c. John ran for an hour/*in an hour.
 d. John ran to the shop in an hour/*for an hour.

The domain to which the term *inner aspect* refers has been observed at least since Aristotle. However, in contemporary linguistic and philosophical traditions, it was reintroduced in Vendler (1957) and Kenny (1963). Other classes of temporal effects fall under the term *outer (or external) aspect* (mainly related to perfective, prospective and progressive meanings) and *tense* (past, future and present).

Inner aspect is often related to the notion of telicity. Traditionally, eventualities are telic if they involve a certain point in time (the *telos*) at which they culminate, i.e. at which the process that they involve reaches some result value. This definition of telicity has some obvious correspondences with the complexity of eventualities. Only complex eventualities have results, and therefore only they can be telic. As presented in sections 4 and 5, certain recent approaches to inner aspect replace the intuitive definition based on having a *telos* with a more complex formal account of the quantificational properties of eventualities and their participants.

Checking how the temporal interval of the eventuality can be measured, i.e. the *for/in* distinction at the beginning of this section (also known as the *adverbial modification test*) is not the only test that can be used to identify inner aspect of particular VPs. There are three other relatively standard tests that are used for the same purpose: the *progressive test*, the *conjunction test* and the *aspectual verbs test*.

Just as the adverbial modification test, the progressive test was introduced in Vendler (1957). It relates to the asymmetry in (15). The telic eventuality in the past progressive in (15a) does not entail its own full realization (i.e. including culmination, completion) in the past: if it is true that John was putting the bag into the closet, it is not necessarily the case that he put it there, i.e. he did not necessarily complete this action. With atelic eventualities, as in (15b), the entailment obviously holds. If it is true that Mary was running in the past, it is also true that she ran.

- (15) a. John was putting a bag into the closet. $\neg \rightarrow$ John put a bag into the closet.¹⁰
 b. Mary was running. \rightarrow Mary ran.

This test relies on the requirement for telic eventualities to take some time until they are fully realized, and to hold only when fully realized. One consequence of this is that no part of a telic eventuality satisfies the full predicate of the whole. The progressive form denotes that a certain interval is a part of a larger interval in which an eventuality is in progress. This means that the progressive selects a proper part of an eventuality to be referred to in the sentence. Since no proper part of a telic eventuality satisfies the predicate of the full eventuality, no proper part of an

¹⁰ For the progressive test, I use the sign ' \rightarrow ' to mark the entailment relation between the two sentences and the sign ' $\neg \rightarrow$ ' to mark that the entailment does not hold.

eventuality will entail this eventuality. The property of the progressive of denoting that the big eventuality is in progress also has consequences for inner aspect. Most directly, they cannot be applied to states, which involve no process and therefore cannot be interpreted as being in progress. As a result, (proper) states do not combine with progressives. Therefore, the progressive is sometimes used directly as a test of the stative nature of a given eventuality or the meaning of a certain verb. This is illustrated by the degraded acceptability of the sentences in (16). It is also the reason why examples for this test take the eventualities of running rather than sleeping, sleeping being normally used to describe a stative eventuality.¹¹

- (16) a. */#John is knowing how high Mount Everest is.
b. */#John is loving his mother.

The same test appears in one more variant, involving the present or past progressive and past perfect forms, as in (17). The mechanisms and intuitions behind this variant of the test seem to be the same as with (15).

- (17) a. John is putting a bag into the closet. $-/\rightarrow$ John has put a bag into the closet.
b. Mary is running. \rightarrow Mary has run.

The *conjunction test* originates in Verkuyl (1972). A temporal modifier of two conjoined phrases, both of which are PPs and both crucially with overt prepositions, specifies the time of the eventuality denoted by the VP. The two conjoined phrases must denote adjacent temporal intervals. Atelic eventualities in this environment raise an ambiguity. The sentence in (18b) can denote either one continuous eventuality of running happening on two days: Friday and Saturday, or two distinct eventualities of running, one on Friday and one on Saturday. The sentence with a telic VP in (18a) can only denote two distinct eventualities of putting a bag into the closet. This lack of ambiguity in the given context identifies telic eventualities.

- (18) a. John put a bag into the closet on Friday and on Saturday.
NON-AMBIGUOUS: 2 putting eventualities;
b. Mary ran on Friday and on Saturday.
AMBIGUOUS: 1 or 2 running eventualities.

It may be not entirely correct to say that atelic eventualities give rise to the reading with one eventuality. Perhaps two eventualities are involved, on two different days, but since these eventualities are described by the same predicates and their intervals are adjacent, it can be inferred that their sum is described by the same predicate.

The proper generalization is therefore that atelic eventualities have the property of forming sums of exactly the same type. Telic predicates, on the other hand, do not have this property. This property, known as *cumulativity* (Hinrichs 1985, Krifka 1992), is in fact one of the central elements of so-called mereological approaches to aspect, which are among those discussed in the remaining part of this chapter.

Finally, *aspectual verbs* are often used to identify the aspectual type of an eventuality. Most commonly, two pairs of aspectual verbs are used: *start* vs. *begin* and *stop* vs. *finish*. The latter pair appears to give stronger intuitions. Atelic

¹¹ Sleeping in fact appears in the progressive, but not in a proper stative meaning. This point is discussed in Chapter III, in the section on progressives.

eventualities, whether stative or not, do not combine with the aspectual verb *finish*, as (19d, f) testifies. The example in (19f) is improved if a telic reading is imposed contextually (e.g. John always runs the same distance). Telic eventualities, however, seem to fall into two different classes. One type, shown in (19a-b), combines easily with either aspectual verb from the pair used in the test. The other type, exemplified by (19g-h), displays the reverse pattern: it is bad with both verbs. (Again, these examples improve under the interpretation that there is a series of reaching eventualities, but such iterative readings are traditionally ignored in tests of aspect.)

- (19) a. John stopped putting the bag into the closet.
 b. John finished putting the bag into the closet.
 c. John stopped knowing the solution.
 d. *John finished knowing the solution.
 e. John stopped running.
 f. *John finished running.
 g. *John stopped reaching the top of the mountain.
 h. *John finished reaching the top of the mountain.

This last observation, which could also have been made in relation to the progressive test, indicates a division that is more fine-grained than simply telic and atelic eventualities. Such divisions have been proposed by many linguists working on this problem, one of the first being Vendler (1957).

2.2. Vendler's classes

One of the earliest attempts to describe the asymmetries displayed by different VPs with respect to inner aspect is Vendler's (1957) classification of eventualities into *states*, *activities*, *accomplishments*, and *achievements*. These four categories are known as Vendler's classes. Vendler defines them rather descriptively, based on their boundedness in time (whether they involve the beginning and the culmination point), and on whether they involve a process. By *process* he means a part of the eventuality presenting an interval in time that involves a homogeneous and by itself unlimited sequence of changes in a certain property.

Examples of Vendler's classes are given in (20).

- (20) a. John loves Mary.
 b. John runs.
 c. Mary builds a house.
 d. John disappeared.
 e. John reached the top.

In Vendler's opinion, *states* are the lightest eventualities with respect to inner aspect. They are not bounded and they do not entail any process. An examples of this type is the eventuality of loving in (20a): it entails that there is a loving relation between John and Mary, where John feels the love; but during no interval of time is a change necessary for the relation to hold. Activities are not bounded either, but they do involve a process. In (20b), there must be a *process* affecting John's location, also involving a movement of his limbs, for the predicate to hold.

Accomplishments are bounded and involve a process: in the eventuality in (20c), there must be a point at which the eventuality of building started and a point at

which it culminated, resulting in a completed house. The period between these points must involve the process of a house progressing in its level of completion.

Finally, *achievements* involve boundedness, but they lack an identifiable process component. They therefore represent an abrupt change, their bounding points being nearly adjacent. In (20d), there is a starting point at which John is present or exists, and the culmination in which John is absent or non-existent. Similarly in (20e), there is a point at which John is not ‘in contact’ with the top and an adjacent later point at which he is. This eventuality may be initiated by John’s action (in which case he also appears as the subject of the predicate *lead_to* in the higher subevent), or not.

Let us now try to link Vendler’s classes to the structure proposed in the previous subsection. Boundedness seems to correspond to complexity since one of the bounding points can be identified with the result (culmination) of the eventuality, and therefore only eventualities with two subevents can have such a bounding point.

Involving a process is linked to the presence of the predicate *lead_to*, which denotes the link between a certain previous state and the state denoted by the result, and corresponds therefore to a change in some property. States are therefore only represented by the lower portion of the general eventuality structure, activities only by the higher portion but without a specified result and accomplishments through a full structure with both subevents taking non-empty predicates.

There is one class that is problematic for the structure used here: the class of achievements, which require a structure with two subevents, but lack the predicate *lead_to* (no process). This should not be possible since one of the two portions of the structure is necessarily headed by this predicate. A possible way to preserve both Vendler’s classification and the structure derived in this section is to have the punctual duration of the eventuality determined by some additional tools, possibly even outside the VP. One option is to define the predicate *lead_to* as not necessarily homogeneous, but unspecified in this respect, having homogeneity, and therefore also the process component, contributed in some other way. The other is to let outer aspect specify a punctual duration for an eventuality, which would impose a reading without a separate process element in the eventuality. These questions are discussed in more detail in Chapters III and IV. Vendler’s classes, with a special status for achievements, are structurally represented in (21).

- (21) a. States: empty higher eventuality b. Activities: empty lower eventuality
 John loves Mary. John ran.

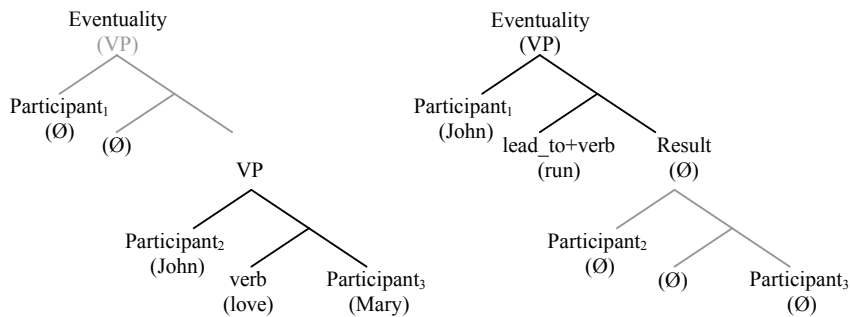

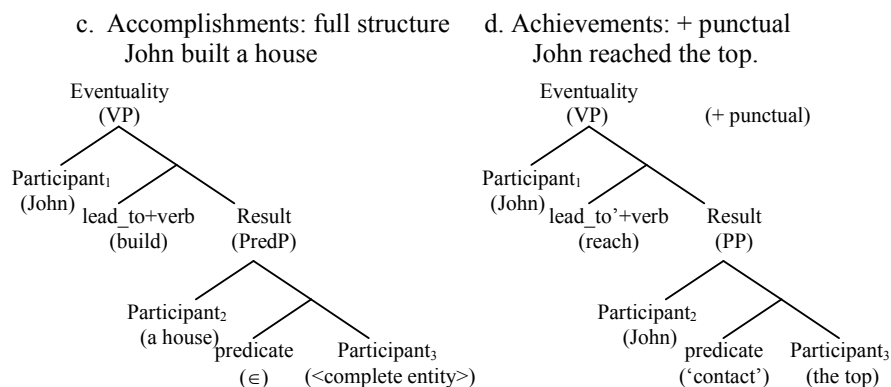

We have ended up with a single structure representing both the argument structure and the inner aspect of an eventuality. At least for the limited range of eventualities discussed, it requires no thematic roles: interpretational properties usually attributed to thematic roles can be derived from the combination of structure and lexically contributed predicates. This means a significant reduction in the computational complexity related to the VP. Furthermore, the structure also represents the dependencies between the two phenomena. In addition, it has very straightforward interface between semantics and syntax.

One of the main goals of this dissertation is to develop a model which includes a direct relation between the argument and aspectual structures while expanding the models of both related domains to cover a number of additional empirical observations. Such a system needs no thematic roles; instead, the relevant properties are read off the structure, in combination with the lexically contributed predicates.

2.3. Summary

This section introduced the notion of inner aspect. It presented the empirical and theoretical reasons to introduce this notion and the four standard tests used to identify inner aspect of an eventuality. Having outlined one of the earliest theories of inner aspect, Vendler (1957), I show how inner aspect can be related to the decompositional structure of eventualities. This relation appears rich enough to allow for capturing inner aspect by the structural patterns of decomposition provided by the syntactic structures introduced in Chapter I.

3. Verkuyl on aspectual composition

3.1. Introduction

So far in this dissertation, inner aspect has been linked to eventualities. However, this is not the only available option: many linguists choose to consider it a property of the verb alone, which the verb then assigns to the eventuality and therefore also to the respective VP. Even Vendler's (1957) classification explicitly deals with classes of verbs, rather than VPs or eventualities.

Henk Verkuyl is one of the first linguists to have argued in a formal linguistic manner that there is more to inner aspect than just the lexical meaning of the verb. In

this section I focus on Verkuyl (1972), and on Verkuyl (1993), which provides a more refined and contemporary version of approximately the same theory.

Verkuyl (1972) starts out with a number of arguments in favor of accounting for argument structure and inner aspect compositionally. He then argues for a particular compositional model of inner aspect sensitive to the features of dynamicity and specified quantity. These two semantic features, explained in further detail in the following subsection, appear on the lexical verb and on its arguments, respectively. Their composition in VP results in the value of inner aspect of the eventuality.

After presenting major aspects of Verkuyl's compositional theory of aspect, I discuss two phenomena that continue to manifest their relevance for the topic of the dissertation in this chapter, as well as in Chapter III. One of them, discussed in section 3.3, relates to a particular set of verbs, like *to push* or *to heat*, which show an ambivalent behavior with respect to (consequences of) dynamicity. The other, discussed in section 3.4, relates to the effects of negation on inner aspect, in particular in cases when negation occurs on the subject of the observed VP.

3.2. The composition of aspect

Verkuyl (1972) observes and tries to capture formally the effects of the type illustrated in example (22). It shows that the verb is not the only element capable of influencing inner aspect. Certain properties of the participants of an eventuality also play a central role in this domain. Using the *for/in*-phrase test introduced in Chapter I, and assuming that telic eventualities are measured by the *in*-phrase and atelic ones by the *for*-phrase, the eventuality of eating in (22a) appears to be telic when a single eater and a single object of eating are taking part in it. Once the eaten object is changed from singular to an unspecified quantity in (22b) (the bare plural form *sandwiches*), the eventuality becomes atelic. The same seems to happen if the eater is assigned an unspecified quantity, as shown in the negative sentence in (22c). This does not prevent the verb from influencing inner aspect: a different verb in the environment of (22a) can also result in atelicity, as shown in (22d). Verkuyl's conclusion based on these examples is that inner aspect (which some grammarians, including Verkuyl himself, also call *lexical aspect*) figures at the VP level and not on the level of the meaning of the verb.

- (22) a. John ate a sandwich in an hour/?for an hour.
 b. John ate sandwiches for an hour/?in an hour.
 c. For an hour/?in an hour nobody ate a sandwich.
 d. John disliked a sandwich for an hour/?in an hour. Verkuyl 2000: 1

This conclusion leads to a new question: which properties of the verb and the participants can influence inner aspect?

In introducing this phenomenon, I described the relevant property of the participants as the lack of a specified quantity. This term originates in Verkuyl's theory of inner aspect. The exact term he uses is *specified quantity of A* (SQA), taking it as a feature that appears on nominal expressions which represent the participants of an eventuality (A, in SQA, stands for the denotation of the lexical noun within the argument). Verkuyl abbreviates this feature as [+/- SQA], where a positive value indicates the presence of the feature on a given constituent, and a negative value its absence. This feature is present if introduced by certain quantifiers

(cardinal numbers like *three*, *twenty*, or other ‘bounded’ ones like *more than three but less than seven*) or by the specificity of the nominal expression (which can either be marked lexically by the definite article or a specificity marker like (*a*) *certain*, or contextually determined). One structural argument bearing [-SQA] is sufficient to obtain an atelic VP (Verkuyl actually uses the term *durative* instead of *atelic* and the term *terminative* instead of *telic*), i.e. for the VP to be telic both structural arguments must be [+SQA].

Similarly, the verb carries information on whether it can build a telic eventuality or not. In Verkuyl’s view, the relevant property of the lexical verb is whether its meaning involves a certain process. Depending on the verb used to describe an eventuality, the interval during which it holds may or may not require there to be a certain change in the domain of the real world that the eventuality relates to. Eventualities involving verbs without a process component leave the world/situation in which they hold unchanged for their entire duration. Nothing is entailed to be added to or taken from the world at any point during their interval. In other words, a process component is a consequence of the denotation of a verb involving a certain dynamics, as opposed to stativity. Eventualities involving verbs like *to turn*, *to hit*, *to slide*, *to reach*, *to redden*, *to lengthen* or *to build* all require that a property of some entity changes its value during the interval in which the eventuality holds. On the other hand, for verbs like *to sleep*, *to shine*, or *to sit*, i.e. verbs usually classified as Vendler’s states, all the properties involved keep all their values identical before, during and after the eventuality.

Verkuyl (1972) uses different terms for different ‘flavors’ of this property, but in his later work he calls this feature *additivity* and introduces the abbreviation [+/-ADD TO], with a positive value for the feature’s presence, and a negative value for its absence. The major difference between this feature and the [+/-SQA] feature, apart from the different categories that they appear on (nominal expressions versus verbs), is that [+/-ADD TO] appears on the lexical unit (the lexical verb), and is determined by some lexical meaning, while [+/-SQA] is determined in the functional domain, since it directly depends on the presence of determiners and quantifiers. With respect to inner aspect, on the other hand, [+/-ADD TO] behaves in the same way as [+/-SQA]. Its absence from the verb (the negative value) makes the eventuality atelic. For an eventuality to be telic, the structural arguments must bear a [+SQA] feature and the verb a [+ADD TO] feature. Verkuyl refers to this as *The Plus Principle*, and it is illustrated in (23).

- (23)
- | | | | | |
|----|---------------|------------------|---------------|----------|
| a. | John | ate | a sandwich. | |
| | [+SQA] | [+ADD TO] | [+SQA] | [+Telic] |
| b. | John | ate | sandwiches. | |
| | [+SQA] | [+ADD TO] | <u>[-SQA]</u> | [-Telic] |
| c. | Nobody | ate | a sandwich. | |
| | <u>[-SQA]</u> | [+ADD TO] | [+SQA] | [-Telic] |
| d. | John | disliked | a sandwich. | |
| | [+SQA] | <u>[-ADD TO]</u> | [+SQA] | [-Telic] |
| e. | John | disliked | sandwiches. | |
| | [+SQA] | <u>[-ADD TO]</u> | <u>[-SQA]</u> | [-Telic] |

Not only are the formal effects of these two features on the inner aspect of an eventuality equivalent, their semantic contents are also related. Both features are strongly linked to quantification. For the [+/-SQA] feature, this is obvious and has already been mentioned above. It is not immediately clear, however, how the [+/-ADD TO] feature, or its intuitive meaning (to which Verkuyl refers as dynamicity, or additivity), relates to quantification.

Nevertheless, this feature does display one quantificational aspect: it is not possible to identify an eventuality involving the feature [+ADD TO] without at least two points in time. No dynamicity can be registered unless the values of the property involved are evaluated at two different points within the relevant temporal interval. This is not the case with the feature [-ADD TO]. eventualities bearing this feature, which are actually states, can be attested by inspecting only one point in time.

Verkuyl (1993) is even more specific about the relation between the feature [+ADD TO] and quantification. He proposes an analysis in which this feature introduces the potential of mapping to a scalar structure. The two points required to register an eventuality with the feature [+ADD TO] are in fact just the minimal form of a scalar structure. Richer scalar structures are equally compatible with the eventualities involving [+ADD TO] verbs. Different participants of the eventuality can contribute to the scalar structure, most notably the Undergoer of the process, but also the Agent (in terms of the structure in Chapter I: the Initiator). Eventualities involving a [-ADD TO] verb do not have the potential of mapping onto a scalar structure irrespective of the participants that they take.

In order to be telic, an eventuality with the [+ADD TO] feature must map onto a bounded scale, and such scales are provided only by the participants bearing the feature [+SQA]. If one or more participants bear a [-SQA] feature, an atelic eventuality is derived. Participants bear the feature [-SQA] if they are mass nouns (which provide no scale) or if they are bare plurals (which provide an unbounded scalar structure). As I already pointed out, one [-SQA] participant is sufficient to make the entire structure atelic. Verkuyl calls these participants 'points of leaking', alluding to the fact that one leaking point in a container is sufficient to make the container leak.

This system can thus derive only three types of eventualities:

1. states (with [-ADD TO]),
2. processes ([+ADD TO], [-SQA]), nearly corresponding to Vendler's activities, and
3. events ([+ADD TO], [+SQA]), covering Vendler's accomplishments and achievements.

Verkuyl explicitly argues that 'there appear to be no grounds for distinguishing Achievement from Accomplishment terms' (Verkuyl 1993:49).

Verkuyl's (1972) system can be represented as in (24) (from Verkuyl 1993). Feature [+T] in the representation stands for *terminativity*, Verkuyl's equivalent of telicity.

(24) a. The composition of aspect

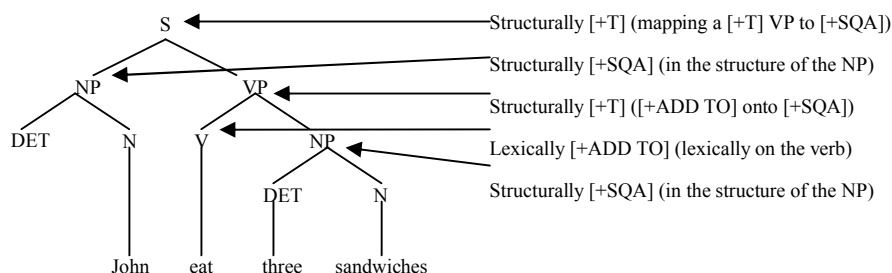

b. The three aspectual classes derived by Verkuyl's system.

NPs: atemporal	+SQA	EVENT	STATE
	-SQA	PROCESS	
		+ADD TO	-ADD TO
verbs: temporal			

In (24a) I reproduce Verkuyl's syntactic representation of aspectual composition. The node S stands, in his words, for what is nowadays usually labelled as the IP. For this reason, what is represented is not only the derivation of inner aspect, but also a higher level of temporal organization of the clause, including the level of the outer aspect and possibly also tense. In the light of current theories of the temporal structure of the clause (e.g. Demirdache & Urribe Etxebarria 1998), the node S could be identified with the phrase in which outer (external) aspect is interpreted, or with the phrase immediately below.¹² The final value for aspect is built in layers, first the dynamicity property allows the verb to map onto the [+SQA] Undergoer, forming a telic substructure, then this structure further maps onto the [+SQA] Initiator, forming another telic structure and closing off the projection of the verb. The figure in (24b) schematically represents the three types of eventualities that the system derives with respect to the features [+/-ADD TO] and [+/-SQA]. Non-dynamic eventualities are states, and dynamic eventualities involve the process component, forming the inner aspect depending on the quantificational properties of the relevant participants.

In his last chapter, Verkuyl (1993) observes that he uses the [+/-SQA] feature as a mere classificational tool. It lacks a formal definition, and only represents an intuitive description of two classes of nominal expressions with two different ways

¹² It is traditionally considered that the position in which the Subject is generated, and which is labelled as the IP, determines tense. This view has recently been questioned by many approaches (e.g. Koopman & Sportiche 1991), leading to the so-called VP-internal hypothesis, according to which the subject is generated within the VP. One consequence of this type of approach is that the position in which subjects are base-generated is related to 'lower' domains of the temporal organization, i.e. to either outer or inner aspect.

of contributing to inner aspect. Therefore, in this last chapter Verkuyl (1993) develops an explicit formalism for the quantificational structure of the NP and its relation to the structure of the VP. Since similar intuitions, albeit in a different kind of formalism, are presented in the following section, I refrain from presenting this part of Verkuyl's work.

To sum up, Verkuyl argues that eventualities are not primitive, and that inner aspect is consequently not a bare property (or a combination of properties) of a primitive unit, but rather that it forms a complex semantic and syntactic unit, composed of different ingredients, all of which correspond to different properties of the verb and the arguments of the VP. He proposes a relatively simple system, involving two features ([+/-SQA] and [+/-ADD TO]), which derives three different aspectual classes of eventualities: states, processes and events. He also explicitly introduces the notion of a mapping between the (sub-)eventuality and the quantificational nature of its participants.

3.3. Remarks on Verkuyl's two types of dynamic verbs

Verkuyl's structure in (24a) illustrates very clearly his general view of the compositionality of aspect with respect to the relevant participants. Structural arguments of the verb take part in building up the aggregate aspect of the VP. This position is problematic for two reasons. The first relates to proper transitive verbs, involving dynamicity ([+ADD TO]), which build eventualities in which a [+SQA] direct object (the Undergoer) and a [+SQA] subject (the Initiator) are not sufficient to derive telicity. This issue is discussed below. The second reason is related to the claim that the Initiator is relevant for inner aspect in the same way that the Undergoer is. A separate discussion of this point would be redundant, since it has been dealt with at length by other linguists (among others Tenny 1994, Ramchand 2002). I do, however, briefly discuss the test Verkuyl uses to argue for his position, given above in (22c), in 3.4, because it opens the interesting question of the relation of negation and inner aspect.

Verkuyl is forced to introduce one complication into his system in order to account for transitive verbs which are [+ADD TO] and still derive atelic eventualities while both their structural arguments are [+SQA]. This is illustrated by the verb *to move* in (25), and holds for similar verbs such as *to push* or *to drive*, but also for different ones such as *to heat*, *to gobble* or *to analyze*. According to the theory presented in this section, the sentence (25) must be telic. However, the test shows that it is not.

(25) John moved the car for three hours/?in three hours.

While it combines perfectly with the *for*-phrase, it can only combine with the *in*-phrase if the context provides a specified quantity of moving. Otherwise the sentence is ungrammatical. This indicates that there is one more participant whose [+/-SQA] feature can act as the leaking point in the aggregate aspect of the eventuality. Verkuyl's solution for capturing these facts consists precisely in introducing such an additional participant in the structure of the VP. He does not insert another argument position for this participant directly in the VP, but instead assumes the verb to be complex, involving an additional argument, as in (26). This

complex structure consisting of a verb and one of its complements is then embedded in the position of the lexical verb in the structure in (24a).

(26) The structure of the sentence *John moved the car*.

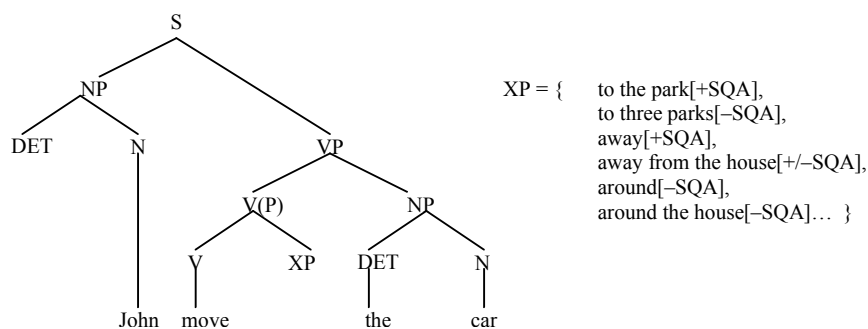

The argument of the embedded VP is not a proper NP but a phrase usually headed by a particle or a preposition. This idea comes from early works on thematic structure, which assumed that there were two variants for each verb of this kind, e.g. *to move* and *to move-to*.

Verkuyl in fact generalizes over the latter variant, replacing *to* with a more general category XP (any phrase displaying this type of behavior). This XP normally includes an NP (usually it is a PP and takes an NP in the complement position), and the [+/-SQA] feature of this NP participates in determining the inner aspect of the VP. Another frequently used option is to assume that the XP is lexicalized as a particle, such as *away* in (26), in which case the particle itself introduces the [+SQA] feature. However, as (26) shows, such an internal XP argument can overtly contribute a leaking point if it (or an NP that it contains) is [-SQA]. Furthermore, a leaking point will appear even if this argument is absent. The latter fact leads Verkuyl to consider that in the instances that do not specify the XP, the XP is interpreted as [-SQA] (i.e. [+SQA] needs to be overt to be interpreted).

In this subsection, I show that Verkuyl's strategy does not solve the problem, since there are strong arguments that the 'non-problematic' verbs require the same modified structure. At the same time, I argue that the structure in (26) does not provide an adequate representation of the VP it is intended for.

As the phrases *back and forth* and *around the house* in (27) show, the leaking point in VPs that involve PP complements may also come from the preposition or from an adverb, and not only from the NP that it selects.

(27) John pushed the car back and forth / around the house for three hours.

This fact requires at the very least an extension of the theory to include the fact that prepositions can also bear the [+/-SQA] feature, with either value.

This is obviously not a serious problem, and with some fine-tuning (including the head of XP in the set of arguments that contribute the [+/-SQA] feature), Verkuyl's structure seems so far to capture the aspectual facts correctly. Furthermore, it does not require the introduction of two different verbs with nearly the same meaning

(e.g. *to move* and *to move-to*), but captures the variable behavior in structural terms. Unfortunately, this structure suffers from two other, much more serious, problems.

The first problem is that it fails to represent some semantic facts about sentences which, in Verkuyl's terms, involve an XP. In particular, the fact that the XP denotes a property of the direct object of the VP (*the car* in (26)) is not represented. An eventuality of this type, if combined with the PPs in (26), involves the result that the car is in the park or away from the house. These constructions are therefore parallel to resultatives (as shown in (28)): without the resultative predicate *flat*, the VP is at least ambiguous between a telic and an atelic reading, but with a strong preference for the atelic one (the telic reading requires a contextually provided quantity of hammering, most naturally determined by a result).

- (28) a. John hammered the (piece of) metal for an hour/in an hour.
 b. John hammered the (piece of) metal flat in an hour/?for an hour.
 c. Jovan je [VP odvezao auto [_{XP} u park]]. Serbo-Croat
 Jovan AUX drove car in park
 'Jovan drove the car to the park.'
 d. Jovan je [VP ofarbao auto [_{XP?} u plavo]].
 Jovan AUX painted car in blue
 'Jovan painted the car blue.'

Furthermore, as the facts from Serbo-Croatian in (28c-d) show, the secondary predicate with a resultative interpretation is structurally very similar to the XP in Verkuyl's structure in (26). In Serbo-Croatian, in fact, it has the same structure and lexicalization (PP headed by the same preposition *u* 'in'). In which case, it seems natural that the representation of the meaning of the sentences in (26) should also represent the fact that the XP is a predicate over the Undergoer (*the car*). Verkuyl's structure cannot achieve this. Note that the same relations are naturally represented in the structure introduced in Chapter I, under the assumption that resultative predicates are generated in the result subevent and the arguments they introduce are represented as Goals. This problem cannot be solved without significant changes in the structure proposed by Verkuyl.

The second problem in Verkuyl's structure is that, once the possibility of embedding a VP is introduced, strict constraints must be specified to delimit which verbs may appear in such structures and what XPs they may take. In fact, there is substantial evidence that this structure applies to a much larger number of verbs than the ones Verkuyl associates it with, perhaps even to every VP.

Many [+ADD TO] verbs which do not require the XP, such as for instance the creation verb *to write*, the consumption verb *to drink* and the verb *to explain* (see (29)), can nevertheless take the same constituents which appear in the XP argument of the complex verbs. Note that these PP complements also contribute to the inner aspect of the VP (Verkuyl uses the term *indexed* for these PPs), as shown in (29). It would be counterintuitive to generate the particles and PPs in examples of this type in a position other than the XP, since their semantic and syntactic contribution differs from that of the typical XPs only in the aspectual effects.

- (29) a. John wrote the poem (down/onto the paper).
 b. John drank (up) a glass of wine (to the bottom).

It appears that the same structure with an XP is available to all the [+ADD TO] verbs, but that two classes of these verbs can be distinguished with respect to the aspectual effects of the structure, one which derives telic VPs with or without an XP, and another one that can yield a telic VP only if it takes an XP.

The problem gets worse due to one aspectual parallel between these two classes of verbs. VPs with standard [+ADD TO] verbs can also have aspectual leaks in the XP (30). Just like the verbs for which Verkuyl introduces the XP, this effect can have two sources within the XP: the [-SQA] nature of its NP complement and the semantics of the element that heads it.

- (30) a. John wrote the poem onto various sheets of paper.
 b. (John likes to write poems on walls.) He wrote his favourite poem around the Parliament for three days.

There is one more property shared by the standard [+ADD TO] verbs and those that Verkuyl considers complex. Both classes of verbs yield slightly degraded sentences when taking a direct object which is [-SQA] and an XP that is lexicalized by a particle, as in (31). The fact that both classes of verbs display this property weakens the view in which they take different structures. The obvious link between the XP and the direct object NP further supports my first point of criticism, namely that the two phrases stand in a predicate-argument relation, a fact which Verkuyl's structure fails to represent.

- (31) a. John drank up a glass/five glasses/?glasses of wine.
 b. John scared away the children that played in the park/
 five children that played in the park/
 ?children that played in the park.
 c. John pushed in the cars/five cars/?cars of different colors.

But if, as I argued here, the complex structure with an XP argument is available for all [+ADD TO] verbs, the problem it is introduced to solve reappears. There are still two classes of [+ADD TO] verbs without an (overt) XP: those that derive telic VPs (32a), and those that derive atelic ones (32b).

- (32) a. John wrote the letter.
 b. John moved the car.

(31) shows that the structure in (26) does not really solve the problem that it was intended to solve (unless if it simply stipulates different properties for different verbs). The two problems I have presented, together indicate that Verkuyl's theory fails to provide explanatory coverage for a large empirical corpus.

3.4. Negation lexicalized on arguments and its effects on telicity

Verkuyl (1993), and even more explicitly Verkuyl (2000), argued that the Initiator has the same type of effect as the Undergoer on the composition of inner aspect. One of Verkuyl's central examples, repeated here as (33), is taken to show that the Initiator with the relevant property ([-SQA]) may present a leaking point for inner aspect. This NP, *nobody*, is considered to be [-SQA] because of the negation.

- (33) a. For an hour nobody ate a sandwich.
 b. ?In an hour nobody ate a sandwich.

This argument is weak for two reasons.

First of all, it is assumed that a negated participant has its [+/-SQA] value determined by the negation, although in the default reading, negation itself scopes over the entire VP. If the negation indeed has wide scope, within the VP the subject is interpreted as a singular, and is therefore [+SQA]. Or, from a different perspective, we might say that the morphology of the argument is singular, and since mass interpretation for it is excluded by the operator that binds it (the negation), this results in a [+SQA] interpretation.

In this view, what the test indicates is the relevance of the negation for the inner aspect. It does not prove however that the Initiator is relevant as well. In other words, a negated eventuality combines with the *for*-phrase and not with the *in*-phrase. As I show in what follows, these sentences can be interpreted with two different scopes for the temporal modification, and the behavior shown in the test in fact appears only with one of the two readings of the sentences in (33), in which the way the *for*-phrase is used does not correspond to its use in telicity tests.

The second weakness in Verkuyl's argument is related to the position of the temporal adverbial. In (33), the *for/in*-phrase is fronted, which is normally not the case when these adverbials are used to test the inner aspect. Observe the sentence in (34), where the adverbials appear in final position.

- (34) Nobody ate a sandwich for an hour/in an hour.

Here both the *in*-phrase and the *for*-phrase are equally acceptable. However, the two phrases bear different scopes with respect to the negation. The *for*-phrase is acceptable only if its scope is wider than the scope of the negation. The entailed reading is that there is an interval during which it holds that there is no eventuality of the relevant kind. The *in*-phrase is acceptable only if scoping lower than the negation. It yields the interpretation that there is no eventuality of the relevant kind such that its temporal interval falls within the interval introduced by the *in*-phrase. The *for*-phrase is ungrammatical if it scopes lower than the negation and the *in*-phrase is ungrammatical if it scopes higher than the negation.

Observe first the acceptable reading of the *for*-phrase, in which the *for*-phrase scopes over the negation, as represented in (35a). Interpreted in this way, the sentence asserts that there was an hour, e.g. between 5PM and 6PM, during which there was no eventuality of completely consuming a sandwich. In this reading, the sentence is false if, during some relevant interval that takes an hour, someone spent ten minutes eating sandwiches and finished at least one of them in this period. However, it is true if someone ate parts of a number of sandwiches during the entire interval introduced by the *for*-phrase (for one whole hour), or possibly longer, but that none of the sandwiches were finished before the relevant interval ended. In the other reading, which is ungrammatical, the negation has wider scope than the *for*-phrase, as represented in (35b). Why it is ungrammatical is quite obvious: it directly combines a telic eventuality with a *for*-phrase.

- (35) a. for an hour < NEG < one ate a sandwich
 b. *NEG < for an hour < one ate a sandwich

Quite symptomatically, in both cases, the reading that matters for the acceptability of the *for*-phrase is the telic one: the one that culminates with the eating of one sandwich being completed. This indicates that in this type of examples, no effect of the properties of the agent on inner aspect of the VP is attested.

Now observe the acceptable reading of the *in*-phrase, the one in which the *in*-phrase scopes lower than the negation. For this reading, represented in (36b), the sentence asserts that there was no eventuality of eating, and completing, a sandwich, such that it took less than or exactly one hour. The sentence is false if someone ate a number of sandwiches, and has managed to finish at least one of them so that the temporal interval of eating this sandwich is shorter than one hour. Therefore it is false if someone spent ten minutes eating sandwiches and finished one of them in that period. On the other hand, it is true if someone spent exactly one hour and one second eating a sandwich, and finished this sandwich at the end of this interval. The ungrammatical reading, represented in (36a), asserts that the interval in which no eventuality of eating and completing a sandwich occurred is shorter or equal to one hour. The ungrammaticality comes from the fact that the meaning of there being no occurrence of an eventuality of a certain kind is [-ADD TO] in Verkuyl's terms and cannot derive telicity. Such a meaning is expected not to combine with the *in*-phrase. In both cases again, ignoring the negation and the temporal modifier, the relevant eventuality is the one that reaches its culmination, i.e. the one traditionally labelled as a telic eventuality.

- (36) a. *in an hour < NEG < one ate a sandwich
 b. NEG < in an hour < one ate a sandwich

We can therefore conclude that the observed eventuality is telic, which is clearly confirmed by the narrow scope of the adverbial (good with the *in*-phrase, not so good with the *for*-phrase). When the adverbial scopes over the negation, it specifies the interval in which the existential quantification over the eventuality is negated. In other words, it specifies the temporal interval of the non-occurrence of an eventuality. The non-occurrence of an eventuality has the properties of a state irrespective of the eventuality itself.

Verkuyl's argument for the claim that subjects take part in the composition of inner aspect cannot hold in the simple way in which it is presented. It is the negation that influences the interpretation of the sentence with respect to the adverbial test, and not the subject itself. This negation, although surfacing on the subject, has independent scope, which may be higher or lower than the scope of the adverbials. The lower scope of the adverbials tests the eventuality without the negation, and indicates telicity. The higher scope of the adverbials tests the non-occurrence of the eventuality and shows atelicity. In Chapter III, I present a model that generalizes over this view in which non-specific arguments of the eventuality (can) have the interpretation of variables.

3.5. Summary

Verkuyl (1972, 1993) develops a formal account for the apparent dependencies between the inner aspect of an eventuality and certain properties of its structural arguments. He proposes a compositional model of eventualities, in which they are built from certain predicates introduced by the verb and a number of participants represented by nominal expressions. Verkuyl defines two features: the feature of dynamicity ([+/-ADD TO]) and the feature of specified quantity ([+/-SQA]). The former is introduced by the verb, while the latter is derived in each of the nominal expressions realizing the structural arguments. For an eventuality to be telic (in Verkuyl's terms: terminative), it must have a [+ADD TO] verb and all its structural arguments must be [+SQA]. A single negative value for any of these properties already results in atelicity.

Verkuyl observes that there is a class of eventualities which are derived from dynamic verbs like *move* or *push*, which are still atelic even though all their structural arguments are [+SQA]. However, if a particle or a Goal participant is introduced, they start behaving as expected. Verkuyl solves this problem by representing the verbs displaying this behavior as complex structures involving an additional, often covert, structural argument. This argument is normally lexicalized as a particle or as a PP headed by *to* (or some other Goal phrase). I have shown that this pattern cannot be restricted only to the class of verbs that Verkuyl targets. In fact, it seems that this complex verb structure is available for a wide range of eventualities and verbs. The problem thus reappears, since in the cases where the argument of the complex verb is not specified, there are still two classes of eventualities with the same structure, but different behavior. I briefly discussed Verkuyl's argument for including Initiators among the set of arguments relevant for the composition of inner aspect. I have shown that this argument does not hold and that what it does show is the effect of negation rather than of the subject. Note that, in this analysis, the negation is lexicalized on an argument of VP, giving a negated nominal expression, but is independently interpreted at some other structural level. A similar view is proposed for quantifiers in Chapter III, section 3.

4. Mereological tools for aspect

4.1. Introduction

Following some earlier approaches to eventualities such as Hinrichs (1985), as well as his own earlier work (Krifka 1989, 1991), Krifka (1992, 1998) develops an algebraic model-theoretic account of the semantics of inner aspect. Methodologically, Krifka wants his model-theoretic account to be compatible with cognitive approaches to semantics (in the sense of Jackendoff 1990, 1996). Therefore, although it is formulated in an algebraic system, his account is supposed to model elements of our mental representations, rather than the real world. One expected gain of this strategy is the reduction of the complexity of the algebra employed in the account to the minimal level required by our cognitive system, and in particular by grammar. This is a reasonable expectation, since it is unlikely that our cognitive system uses all the tools that nature makes available. Krifka takes an Aristotelian view of time and defines his algebra over intervals and their properties,

without resorting to points (the way it is done in the Cantorian approach of Verkuyl 1993). Non-atomic intervals are not built using temporal points, but using other intervals. The same holds for other similar structures, such as paths, which are built from other paths.

The fundamental tool in Krifka (1998), as well as in most of other Krifka's work in this field (though with certain variations), is a simple algebraic model defined over the *part* relation. In semantics, such a model is traditionally referred to as a *mereological approach*. It derives *part structures*, also called *mereological structures*, to which all the derived complex structures belong. The main reason for choosing a mereological approach is the fact that the central position in most approaches to inner aspect belongs to variations on the so-called *subinterval property*. Within an approach to eventualities based on their temporal structure, the subinterval property offers a way of generalizing over the difference between telic and atelic eventualities. Eventualities are viewed as predicates corresponding to temporal intervals, and their relevant features are expressed in terms of temporal relations. An eventuality has the subinterval property if, holding for a certain interval, it also holds for all parts of this interval.

An interesting case of lacking the subinterval property occurs when the eventuality is bounded. In this case, the boundaries of the eventuality present parts of its predicate, and must be present in every interval for which it holds. No continuous proper part of the interval of such an eventuality will at the same time contain both boundaries of this eventuality (which also means containing both boundaries of the interval). Therefore, bounded (or telic) eventualities do not have the subinterval property, whereas atelic eventualities do. To illustrate this, consider (37a), where the eventuality of John sleeping holds for all parts of the full interval of the eventuality. On the other hand, unless there is a covert iterative operator, the interval referred to in (37b), which covers the eventuality of John reading the book from beginning to completion, has no proper parts in which John also begins and completes his reading of the book.

- (37) a. John slept.
b. John read the book.

In a temporal approach, one additional difference between telic and atelic eventualities relates to the subinterval property. Many researchers working on inner aspect, including Verkuyl (1993), make use of properties such as *punctual* or *continuous* in their definitions of telicity. Punctual predicates are those that can be verified at a point in time, and continuous predicates are those that require an interval in order to be verified. A predicate can be verified at a point in time only if it has the subinterval property (since in that case all its parts, even single points, have the same predicate) or if it only takes a point in time. The former case relates to states, which involve no change whatsoever. The latter (which is quite controversial) relates to Vendler's achievements, which are assumed, at least in some approaches, to be punctual.¹³ The eventualities that require more than one point to be verified are

¹³ The case of achievements is controversial because at least some achievements are characterized by involving a change, i.e. the world or the discourse domain is not the same before and after the eventuality.

called continuous, or non-punctual. These are Vendler's activities (Verkuyl's non-terminative, i.e. atelic, dynamic eventualities) and Vendler's accomplishments (Verkuyl's terminative, i.e. telic, dynamic eventualities).

We can now introduce a number of correspondences between the relevant properties of eventualities on the one hand, and the relevant properties of the participants and the verb on the other, an issue which has to some extent already been dealt with in the preceding section. Logically, the next step is to try to derive a model of relevant properties of the predicate of an eventuality and its participants, and of how they conspire to determine the subinterval property or its counterpart in the given model. In his last chapter, Verkuyl (1993) offers one such model, trying to provide a precise idea of the semantic import of the [+/-SQA] feature. Krifka (1992, 1998) has a similar aim, and a similar approach, although his analysis is broader and poses a number of new interesting questions.

4.2. The global picture: verbs, thematic roles, types of reference

Krifka (1992) is similar to Verkuyl's (1993) last chapter: he intends to provide a formal and explanatory account for the properties of nominal expressions that affect the properties of eventualities. In other words, both authors explore the mechanisms of mapping between properties of eventualities that are related to inner aspect and to the temporal organization and the non-temporal properties of nominal expressions. Along the lines of his earlier work as well as the work of, among others Dowty (1979) and Tenny (1994), Krifka (1992) takes this type of mapping to be specified in the meaning of certain thematic roles. One way in which thematic roles are grammatically relevant is through their interaction with inner aspect. Based on an intuitive understanding of the subinterval property, Krifka defines this interaction in terms of abstract mereological relations between different predicates.

Krifka operates with two directions for the mereological mapping between eventualities and their arguments. The first one is from the predicate of a nominal expression appearing as an argument of the verb onto the predicate of the verb, i.e. onto the predicate that describes the eventuality. The other direction of mapping is the opposite: mereological properties of the predicate that describes the eventuality are mapped onto one of the arguments of this eventuality. A part of the meaning of a thematic role, as a particular relation between the predicate of an eventuality and the predicate of one of its arguments, is to specify whether any such mapping is established between the argument and the eventuality. Note that Krifka's account heavily relies on thematic roles.

Krifka compositionally derives the predicate of an eventuality, which is then taken as the description of an event argument. Event argument is an argument of the verb, but its reference is fully determined by the interpretation of the VP. This makes the event argument different from other arguments of the verb, because they establish reference independently of the VP, and they are introduced into the eventuality via thematic roles. A further asymmetry between the event argument and arguments representing event participants is that only the event argument is always assigned a temporal interval. See Verkuyl (2000) for a discussion of this type of asymmetries.

This means that at least two points in time are required to attest to such an eventuality: one to attest to the state before and the other to the state after the eventuality has taken place.

Depending on the meaning of the lexical verb used, and in particular on the number and type of thematic roles involved, the same reality can be described in different ways, i.e. through different eventualities, depending on the 'point of view' taken, especially with respect to the temporal structure of the eventuality. In this way, the same reality can be described both by a telic and by an atelic eventuality. Inner aspect is in this view directly dependent on the predicate of the event argument, which is derived from lexical properties of the verb in interaction with the nominal expressions linked to the relevant thematic roles.

Krifka relates mereological properties of predicates to the way in which they establish reference and therefore he refers to the mereological properties relevant for his theory as *reference types*. The lexical verb is specified for whether it licenses (or even requires) a certain thematic role, while the properties of this role determine the further relations between the reference types of the eventuality and its participants.

In (38) the verb *to run* is specified as mapping between the reference type of the eventuality it semantically specifies and that of its direct object. If a participant with this thematic role is not provided, the eventuality will be atelic, as in (38a). If such a participant is available, then similarly to Verkuyl (1972), the relevant properties of distance will be mapped onto the eventuality. This gives us the telic eventuality in (38b) and the atelic one in (38c).

- (38) a. John ran.
 b. John ran a mile.
 c. John ran miles.

The thematic role can just as well specify whether a certain argument is unique for the eventuality, and *vice versa*: whether the eventuality is unique for the argument involved. For instance, a telic eventuality described using the verb *to eat* (or other verbs of consumption/creation) necessarily displays uniqueness of the Undergoer, since a certain object can be eaten only once.¹⁴ On the other hand, with the verb *to run* (38) (or other similar verbs such as *to read*, *to watch*, etc.), no such uniqueness can be observed: someone can run the same path or read the same (passage of a) book an unlimited number of times.

Other participants, such as Goals and Sources, may entail boundaries for an eventuality and therefore make it telic, but by other means than mapping. These two particular roles, Krifka defines in terms of adjacency of intervals applying to the initial and final intervals of an eventuality. In order to have its initial and final intervals adjacent with some other interval, an eventuality needs to be bounded, and therefore telic as well.

This view obviously differs from the one of Verkuyl, where all the relevant participants have the same mechanism of interacting with inner aspect. For Krifka, not only are there different mappings between the eventuality and its participants, but in addition some roles have properties which cause effects independent of the mereological relations.

¹⁴ I will use the term *Undergoer* when discussing Krifka's theory, although Krifka himself does not use it (he uses the rather neutral term *object*). However, the meaning of the term *Undergoer* is by now well established and it also makes it easier to fit Krifka's theory in the general picture.

Apart from this difference, Krifka's approach runs parallel to Verkuyl's: there is one property appearing on the verb (for Krifka this is the thematic role), and another property shared by the eventuality and the nominal expression realizing the mapping role (for Krifka the reference types). The property on the verb licenses the mapping between the property on the nominal expression and the inner aspect of the eventuality. Comparing this with Verkuyl's analysis, one might say that a thematic role which involves any mapping, corresponds approximately to the [+ADD TO] feature. Mereological properties correspond to Verkuyl's [+/-SQA] and his terminativity (for the latter, Krifka uses the term telicity).

One technical difference lies in the fact that, in Krifka's work, the property of the nominal expression (the reference type) and the property of the eventuality (telicity) are represented through the same mereological structure, while Verkuyl takes them as two different features.

The following subsection contains a more detailed sketch of the mereological notions and Krifka's view on the relation between eventualities and their participants. I will concentrate on that part of his model that parallels Verkuyl's, not only because in that way the differences between the two models presented so far are highlighted.

4.3. Quantization and cumulativity

Krifka (1992, 1998) builds his account for telicity around two phenomena that have already been introduced in the previous section. One of them is the mapping capacity, corresponding to Verkuyl's [+/-ADD TO] feature, and the other one involves those properties of eventualities and of the relevant participants involved in this mapping, parallel to Verkuyl's [+/-SQA] and terminativity.

Properties involved in the relevant mappings concern the relation between parts and the whole of a certain referent with respect to the predicate that describes it. Krifka calls these properties *reference types*, and recognizes two such types as relevant for the aspectual structure of the eventuality. The terms Krifka uses for these two reference types are *cumulative* and *quantized* reference, and they are defined as in (39).

(39) a. *cumulativity*: $\forall P.CUM(P) \Leftrightarrow [\forall x, y.P(x) \wedge P(y) \Rightarrow P(x \oplus y)]$;

A predicate P has cumulative reference iff whenever it holds for two entities x and y, it also holds for their sum (\oplus stands for the sum relation, an idempotent, commutative and associative function from the Cartesian product over a type, in this case the one of predicates, to the type itself: $U_P \times U_P \rightarrow U_P$).

b. *quantization*: $\forall P.QUA(P) \Leftrightarrow [\forall x, y.P(x) \wedge P(y) \Rightarrow \neg(x < y)]$;

A predicate P has quantized reference iff whenever it holds for two entities x and y, the entities do not stand in a proper part relation (<).

Just as Verkuyl's (1972) [+/-SQA] feature, reference types are particularly sensitive to the meanings of quantifiers and determiners. Bare plural and mass nouns always represent cumulative predicates, and quantified expressions can be of either type, depending on the quantifiers involved. Specific and definite NPs are all quantized.

Quantization of the eventuality or of its temporal interval stands in exclusion with the subinterval property, which usually goes together with cumulativity. When the

predicate of a participant has cumulative reference and its thematic role involves mapping of its reference type onto that of the eventuality, the eventuality will also have cumulative reference. Every cumulative eventuality is also atelic. The same holds for quantization: a quantized participant with a thematic role that maps its reference type to the eventuality will make the eventuality quantized. However, Krifka makes no use of the syntactic structure and does not reserve the property of telicity for (narrow) VP predicates. For him, in sentences like in (40), eventualities are judged for aspect after being modified by temporal adverbials. Temporal modification bounds the temporal intervals of these eventualities and therefore makes them telic, although before temporal modification both eventualities are cumulative and would qualify as atelic.

- (40) a. John ran for ten minutes.
b. Mary wrote letters from five o'clock till midnight.

This means that Krifka does not completely identify telicity with quantization of the very predicate of the eventuality. In his view, telicity is a slightly broader notion, sensitive both to the predicate of the eventuality and to its temporal interval, which Krifka treats apart from the eventuality itself.

Krifka's precise definition of telicity runs as in (41).

- (41) $\forall P \subseteq UE [TEL(P) \Leftrightarrow \forall e, e' \in UE [P(e) \wedge P(e') \wedge e' \leq e \Rightarrow INI(e', e) \wedge FIN(e', e)]]$
A predicate P, which applies to eventualities, describes a telic eventuality iff for every pair of eventualities e and e', where the predicate P holds for both eventualities and e' is part of e, e' is an initial part of e and at the same time e' is a final part of e.

This definition is supposed to include eventualities that are telic as a result of the boundedness of their temporal interval rather than to the quantization of (the remaining part of) their predicates. Since this chapter is mostly concerned with the interaction between argument structure and inner aspect, the most important ways for an eventuality to be telic are those involving the mereology of its predicate.

In the strictest case of mapping for Krifka, the thematic role specifies not only a bidirectional mapping between the eventuality and the participant, but also the respective uniqueness. Krifka takes this to be derived from the lexical meaning of the verb, and to hold most obviously for the consumption and creation verbs, because the same entity cannot be consumed or created again: an object can take part in at most one eventuality of consumption or creation. The sentences in (42) illustrate this kind of thematic role on the participant *apple*.

- (42) a. John ate an apple in an hour/?for an hour.
b. John ate apples for an hour/?in an hour.
c. Petar je jeo jabuke. Serbo-Croatian
Petar AUX eaten apples.ACC
'Petar ate apples.'
d. Petar je po-jeo jabuke.
Petar AUX OVER-eaten apples.ACC
'Petar ate up the apples.'

In (42a), the nominal expression *an apple* is quantized: no proper part of an apple can also be an apple. Since this participant bears a thematic role which involves mapping with the reference type of the eventuality, its quantized reference will be mapped onto the otherwise mereologically unspecified predicate of the eventuality. The predicate of the eventuality is in this way made quantized, i.e. telic. On the other hand, in (42b), the object is cumulative (put two entities referred to as *apples* together: the resulting set will still be referred to as *apples*). This reference type is mapped to the eventuality, and the eventuality becomes cumulative, and hence atelic.¹⁵ Krifka assumes that the other direction of mapping, from eventualities to participants, is instantiated in Slavic languages, which show overt marking of aspect on the verb, as in (42c-d). The nominal expression *jabuke* (apples) in both examples is a bare plural, neither marked for specificity nor for definiteness. Nevertheless, in (42d), where the eventuality is telic due to the morphological marking on the verb,¹⁶ the nominal expression must be interpreted as necessarily specific and preferably definite as well. In (42c), on the other hand, where the eventuality is atelic, the noun is fully ambiguous between a definite and an indefinite reading.

Finally, Krifka (1998) discusses eventualities involving a process, and even some instances of mapping between the Undergoer and the eventuality, but where a quantized Undergoer without any additional specification fails to map its reference type to the predicate of the eventuality. These verbs are illustrated in (43).

- (43) a. John pushed the cart for an hour/?in an hour.
 b. John pushed the cart to the shop in an hour/?for an hour.
 c. John pushed carts to the shop for an hour/?in an hour.
 d. John pushed the cart to shops for an hour/?in an hour.
 e. John hiked for an hour/?in an hour. (but: John sank in an hour/?for an hour)
 f. John hiked the Vernal Falls path in an hour/?for an hour.
 g. People hiked the Vernal Falls path for ten days/in ten days.
 h. John heated the water for an hour/?in an hour.
 i. John heated the water to 90 degrees in an hour/?for an hour.

The eventuality of pushing the cart is cumulative and atelic in (43a), where no particular Path and no particular Goal is specified. A similar eventuality which also includes a quantized Goal is however telic (43b). Finally, if a Goal is included, but either the direct object (usually the Undergoer) or the Goal itself is cumulative, as in (43c) and (43d) respectively, the eventuality is atelic. This means that for eventualities of this type the presence of the Goal (or, as it appears in (43f), of a Path) is a precondition for any mapping. When such a participant is present, the role of the Undergoer involves mapping and when it is absent, no mapping occurs. Crucially, in these eventualities the Undergoer role does not involve uniqueness with

¹⁵ Krifka uses a large number of algebraic formulae (over 20 notions defined in the 1998 article alone) to describe many of the phenomena dealt with in this chapter and a number of others that he considers relevant. I only gave the two that define cumulativity and quantization, since they are central to his model, and are moreover relevant later on in this chapter. For the rest of the formalism, see the original papers (Krifka 1992 and 1998).

¹⁶ The prefix is in fact traditionally analyzed as introducing perfectivity (related to outer aspect) rather than telicity. Krifka is aware of this fact, but he assumes that perfectivity can only combine with a telic eventuality, thus imposing a telic reading, which further determines the definite reading on the object.

respect to the eventuality. Krifka calls these eventualities *movement eventualities* and attributes to their Undergoer role the *movement relation*. This relation is associated with a number of other notions (such as *Path*, *Source*, *Goal*), together meant to capture a number of facts related to this kind of eventualities, such as the relation between the presence of the Path and inner aspect.

Although Krifka (1998) relates the observed class of eventualities to the movement relation, he notes that a number of other eventualities have similar properties. Examples of such eventualities, in which no actual movement in space is involved, are provided in (43h-i). Nevertheless, the process involved in these eventualities has the same properties as physical movement along a path since a linear directed change in the value of a certain predicate is involved (Krifka uses the notion of an extensive measure function, applied to paths of movement, to capture this fact).

Krifka's account of the movement relation is such that it involves the notions of a Path, Source and Goal and assigns to these notions definitions which more or less directly make the eventuality telic. He does not discuss the fact that these participants appear to involve thematic roles which also map onto the eventuality, as illustrated in (43b-d) and (43e-f).

To summarize, Krifka (1992, 1998) formulates a mereological algebra, which he then uses to describe two general types of predicates with respect to reference: the cumulative predicates and the quantized predicates. In a slightly simplified formulation, cumulative predicates are preserved under sum and quantized predicates are not. Taking thematic roles to be links between the participants and the eventuality, Krifka derives the effects of the properties of participants on inner aspect from relations involved in a certain thematic role, such as, for instance, bidirectional mapping between the reference type of the relevant participant and the eventuality. Telic eventualities minimally have quantized temporal intervals (with the entire predicate often being quantized as well) and atelic eventualities are all cumulative. Ways of deriving telicity that do not involve only the relations of mapping and uniqueness are captured by more complex definitions, involving properties of the temporal interval and some additional notions such as Paths, Sources and Goals.

4.4. Divisiveness and the parallel between reference types and entailment

In the remaining of this section, I discuss different interesting points in Krifka's theory. The purpose of the discussion is not so much to criticize Krifka's theory or suggest modifications, but rather to point to some curious theoretical problems undermining the mereological way of looking at eventualities. The linguistic relevance of some of these problems exceeds the domain of eventualities and mereology. In this subsection I discuss the number of mereological reference types available in natural language, in 4.6 I deal with a particular type of quantifiers that involve parameter values, and in 4.7 I turn to the roles of Paths, Goals and Sources.

In this subsection, I examine the property of divisiveness, a third possible reference type, in addition to cumulativity and quantization. The introduction of this property enables establishing an interesting parallel between the mereological notion of reference types and the set-theoretic notion of entailment.

Not all natural language predicates can be placed into the classes determined by cumulativity and quantization. The question is therefore: Are there more interesting classes, possibly covering the predicates in natural language that are neither cumu-

lative nor quantized? The predicates which escape both these categories (but also some predicates that display cumulativity) can be properly described using the property of *divisiveness*, defined in (44) (this particular definition is from Filip 1997; Krifka also gives a definition of this reference type, but does not discuss the class of predicates extensively).¹⁷

- (44) divisiveness: $\forall P. \text{DIV}(P) \Leftrightarrow [\forall x, y. P(x) \wedge y < x \Rightarrow P(y)]$;
A predicate is divisive iff when it holds for a certain entity it also holds for every proper part of this entity.

The introduction of the property of divisiveness provides an interesting background for Krifka's entire mereological system. The cumulative property can be seen as a mereological counterpart to upward entailment and the divisive property as a counterpart to downward entailment.

A quantifier is upward entailing for one of its two arguments if a true expression involving such a quantifier keeps its truth value when the relevant argument is replaced with its superset (see, among others, Ludlow 2002). The definition of downward entailingness is parallel, only the relevant argument has to be replaced with its subset. This is formally presented in (45a, b). (45c) is a reformulation of (45b) that is more suitable for establishing the aimed parallel with reference types.

- (45) a. downward entailingness:
 $\forall Q. \downarrow(Q) \Leftrightarrow [\forall X, X', Y. Q(X, Y) \wedge X' \subseteq X \Rightarrow Q(X', Y)]$.
 b. upward entailingness:
 $\forall Q. \uparrow(Q) \Leftrightarrow [\forall X, Y. Q(X, Y) \wedge X \subseteq X' \Rightarrow Q(X', Y)]$.
 c. upward entailingness:
 $\forall Q. \uparrow(Q) \Leftrightarrow [\forall X, Y, Z. Q(X, Y) \Rightarrow Q((X \cup Z), Y)]$.

This is illustrated for the upward entailing quantifier *some* and the downward entailing *no* in (46). Arguments are replaced by their supersets (to show the upward entailment) in (46a) and with their subsets (for the downward entailment) in (46b).

- (46) a. Some black birds fly. \rightarrow Some birds fly.
 No black birds fly $\neg \rightarrow$ No birds fly.
 b. Some birds fly. $\neg \rightarrow$ Some black birds fly.
 No birds fly \rightarrow No black birds fly.

With the formulation of upward entailingness in (45c), the parallel is obvious, although not full, as represented in (47).¹⁸

- (47) a. $\forall P. \text{DIV}(P) \Leftrightarrow [\forall x, x'. P(x) \wedge x' < x \Rightarrow P(x')]$;
 a'. $\forall Q. \downarrow(Q) \Leftrightarrow [\forall X, X', Y. Q(X, Y) \wedge X' \subseteq X \Rightarrow Q(X', Y)]$.
 b. $\forall P. \text{CUM}(P) \Leftrightarrow [\forall x, z. P(x) \triangle P(z) \Rightarrow P(x \oplus z)]$;
 b'. $\forall Q. \uparrow(Q) \Leftrightarrow [\forall X, Y, Z. Q(X, Y) \Rightarrow Q((X \cup Z), Y)]$.

¹⁷ Filip (1997) shows that quantized predicates are in complementary distribution with the union of the cumulative and divisive ones, as in (i). In other words, every predicate has at least one of the three properties and every predicate that is not quantized will be either divisive or cumulative, or both.

(i) $\text{QUA}(P) \Leftrightarrow \neg [\text{CUM}(P) \vee \text{DIV}(P)]$

¹⁸ Letters used for variables in (47) are different than usual to point out the parallel.

Divisiveness and downward entailingness are fully parallel, the only difference being that quantifiers are two-place predicates and reference types are by default defined over one place predicates. Cumulativity and upward entailingness have the same kind of parallel, except for one asymmetry: cumulativity has one additional restriction, underlined in (47b): the predicate P needs to hold for both arguments of sum. For upward entailment, however, one member of the union is unrestricted. In 5.3, I present the definition of divisiveness from Borer (2005a, b), which establishes a fully analogous asymmetry between divisiveness and downward entailingness.

4.5. How many reference types?

In the light of the preceding subsection, Krifka's proposal can be seen as avoiding the complexity of a model based on set-theoretic relations and such a model's rather unintuitive application to eventualities, by choosing a mereological approach. His mereological approach targets predicates rather than the actual referents of nominal expressions and of eventualities. This brings the two different categories to the same level, allowing them to map onto one other.

In this subsection, I discuss the number of reference types and the number of inner aspect values, presenting a view in which all divisive predicates in natural language are also cumulative, and all cumulative predicates are also divisive. This confirms Krifka's binary classification of predicates. In the end, I reexamine the telicity tests applied to eventualities with supposedly divisive non-cumulative Undergoers and conclude that the quantifying component of the denotation of such arguments is interpreted outside of the domain of the eventuality and therefore does not interact with the inner aspect value of the eventuality.

All else being equal, Undergoers bearing the three properties that we defined in 4.4: divisiveness, cumulativity and quantization, should still map onto the reference type of the eventuality, if their thematic role involves mapping. Strictly applying Krifka's mapping, it is possible that, apart from quantized and cumulative predicates of eventualities, there is a third reference type, potentially corresponding to a third type of inner aspect. It is worth investigating whether there are eventualities that might form this class. Since cumulativity and divisiveness do not exclude each other, the natural direction to check whether there are three types of aspect is to look at those nominal predicates that are divisive but not cumulative, or cumulative but not divisive, and to see how they map onto the reference type of the eventuality. A standard example is provided in (48), which contains the nominal expression *less than three sandwiches*.

- (48) a. John ate less than three sandwiches ?for an hour/in an hour.
 b. John was eating less than three sandwiches. → John ate less than three sandwiches.
 c. John ate less than three sandwiches on Tuesday and on Wednesday. – one reading
 d. ??John finished eating less than three sandwiches. (for the non-specific narrow scope reading, when *finish* must scope over *less than three*)

The predicate *less than three sandwiches* is not cumulative, because two sandwiches are less than three, but the sum of two sandwiches and two sandwiches is not. It is obviously not quantized either, since two sandwiches are less than three sandwiches

and one sandwich is a part of two sandwiches, while still being less than two sandwiches. Finally, it is divisive since no part of any quantity of sandwiches that satisfies the predicate *less than three sandwiches* can be anything else but sandwiches. At the same time its quantity, being a proper part of less than three sandwiches, can be neither more nor exactly three sandwiches.

In the sentences in (48), a nominal expression with this predicate appears as the Undergoer, with a thematic role that maps its reference type to that of the eventuality. These sentences represent the four standard tests of inner aspect introduced in Chapter I, section 3, which appear to give mixed results. The adverbial modification test in (48a) seems to indicate that the eventuality is telic: it combines well with *in*-phrases and is markedly worse with *for*-phrases. On the other hand, the progressive test in (48b) shows that the eventuality is atelic, since the past progressive sentence entails the simple past one. If John was engaged in eating less than three sandwiches, he has eaten at least a part of a sandwich, but whatever he has eaten is still less than three sandwiches. The conjunction test in (48c) indicates telicity: although it is difficult to obtain clear judgments, most speakers that I asked agree that the reading with only one eventuality of eating is quite obscure with the quantifier scoping low. The aspectual verbs test in (48d) again points to atelicity (unless we are dealing with an achievement, or unless other factors are involved): it is impossible to combine this eventuality with the verb *to finish* without imposing a specific reading on the Undergoer (the only available reading is related to the quantity and not the event: a specific natural number of sandwiches such that John has finished them is smaller than three; but then the Undergoer is quantized).

Confronted with different results of the four tests for the same eventuality, if they are properly applied, we can conclude that there are more types of inner aspect than the two postulated. But it is not yet excluded that there is something wrong with the tests, either in the way they are applied, or in what they are really showing. In fact, I show in the remaining part of this subsection that this is exactly the case, and that there inner aspect can take only two values.

Let us investigate the possibility that the tests were not interpreted properly in (48). In particular, let us follow the reasoning suggested in Krifka (1998), that in some cases due to different scope issues apparently non-quantized arguments with thematic roles that map them onto the eventuality still give rise to telic eventualities. This possibility may be confirmed by two possible results. Either the divisive non-cumulative Undergoers always derive telic eventualities, meaning that only cumulativity matters and the entire non-cumulative range derives telic eventualities, or vice versa: this kind of Undergoers give rise to atelic eventualities, implying that only quantization matters, and all the non-quantized eventualities are atelic.

Krifka (1998) observes the problem that certain types of predicates in nominal expressions appear cumulative, and although their thematic roles map their reference type to that of the eventuality, eventualities derived are telic. Krifka offers an explanation in terms of scopal relations. He notes that all the nominal expressions with this behavior include a quantifier that may scope outside of the domain relevant for inner aspect. Presented in a simplified way, this means that the semantic component of the predicate of the nominal expression which makes the nominal expression cumulative is interpreted outside of the domain of interpretation of the eventuality. Instead of the full nominal expression with a cumulative predicate, the

eventuality involves only a variable. The variable in Krifka's view behaves as a name and therefore has a default singular interpretation.

Krifka's explanation is not originally formulated to address the problem of predicates involving parameter values, but it applies to these predicates as well. Each quantifier that involves a parameter value also involves a comparative. The meaning of comparatives crucially relates to the degree of some property, and this degree component is usually related to the syntactic projection of Degree Phrase (DegP). There is a consensus in the literature that the interpretation of degree, and the projection of DegP, is structurally located higher than VP, and thus outside the domain in which the eventuality is structurally represented (see Heim 2000 for an extensive discussion and list of references). This is illustrated in (49).

- (49) a. John ate less than three sandwiches (in an hour/?for an hour).
 b. $\exists X, x, y, e, n$ $[[x \in X \leftrightarrow [\text{sandwiches}(x) \wedge \text{John}(y) \wedge \text{eat}(e, y, x)]]_{\text{PRESUPP}} \wedge [\max(|X|) < 3]_{\text{ASSERT}}]$
The maximal number/quantity of sandwiches that John ate is smaller than the one of three sandwiches.

The meaning of the sentence in the example involves two different propositions. One, which is usually presupposed, is that there was an eventuality of eating something that has the property sandwiches. The other, which is usually asserted in the sentence, is that the maximal quantity of sandwiches eaten is less than three.

Krifka's explanation is correct for the predicates involving parameter values: they indeed have to be interpreted in a higher domain. This higher interpretation binds a variable inside the VP. The variable, corresponding to the relevant participant, is quantized and when the thematic role maps from the participant to the eventuality, the eventuality becomes quantized, and therefore telic as well (Krifka 1998: 21).

Now we can go back to the tests in (48). Two of the tests, (48a, c), show that the eventuality is telic, which agrees with the conclusions reached above. But why do the other two tests, (48b, d), show that the eventuality is atelic?

(48b), repeated in (50), applies the progressive test.

- (50) John was eating less than three sandwiches. \rightarrow John ate less than three sandwiches.

It appears that indeed the sentence involving the progressive of the eventuality entails the sentence involving the same eventuality in the simple past. But recall that the quantifiers involving parameter values, like the one in (50), are interpreted in some domain higher than VP. This domain is also higher than the projection responsible for the progressive interpretation (structural representation of the progressive is discussed in Chapter IV, section 3.3), which means that the quantifier scopes over the progressive. Now we only have to connect the two striking properties of the progressive test and of the relevant predicate. One is that the progressive test involves entailment and therefore is sensitive to the entailingness of the context in which it appears, and the other that the quantifier *less than three*, which has a wider scope, is downward entailing. The progressive asserts that part of an eventuality took place (see 3.3 for a discussion and references). Due to the subinterval property of atelic eventualities, a part of an atelic eventuality satisfies the

same predicate as the entire eventuality, so the predicate of the entire eventuality takes the value *true* as well. Telic eventualities do not have the subinterval property: the predicate of the entire eventuality does not hold of any of its parts. Therefore, the eventuality in the progressive does not entail the one in the simple past. But the quantifier *less than three* scopes over both VPs and establishes a downward entailing context, in which we expect a different entailment. Thus the entailment between the sentence with the progressive and that with the simple past does not indicate atelicity of the eventuality, because it is influenced by the downward entailment of the context.

The sentence in (50) is in this sense parallel to the one in (51), in which we have a clearly telic eventuality, but the entailment again holds due to the downward entailing context established by a higher element.

- (51) On less than five days, John was eating a sandwich. → On less than five days John ate a sandwich.

The element that establishes this context contains the same quantifier as that in (50).

A further argument in favor of this explanation for the result of the test in (50) is that if we try the same test with the kind of quantifier that is traditionally expected to give a cumulative non-divisive predicate, and which is upward entailing, the entailment between the progressive and the simple past holds no more (52a). That the parallel is complete is confirmed in (52b), with the same kind of quantifier in a constituent that is not generated as a structural argument of the verb.

- (52) a. John was eating more than three sandwiches. -/→ John ate more than three sandwiches.
 b. On more than five days John was eating a sandwich. -/→ On more than five days John ate a sandwich.

The discussion showed that the progressive test in (48b) does not give results that oppose those of the other tests in (48), i.e. that it is fully compatible with the claim that the eventuality in the example is telic. The only remaining problem is the result of the test using the aspectual verb in (48d), repeated in (53).

- (53) ??John finished eating less than three sandwiches. (for the non-specific narrow scope reading, when *finish* must scope over *less than three*)

After the discussion of the quantifier involved, where I concluded, following Krifka (1998), that the quantifier scopes relatively high and certainly higher than VP, the problem ceases to exist. As noted in brackets, this test requires that the quantifier scopes lower than the aspectual verb, which it cannot. The test is therefore simply non-applicable: it targets a reading that is impossible. The problem is completely solved: all the tests used in (48) agree about the fact that the eventuality observed is telic. The consequence for the number of reference types is that nominal expressions involving parameter values do not indicate any relevance of the difference between divisiveness and cumulativeness for inner aspect, i.e. that the distinction between quantized and non-quantized predicates is sufficient.

4.6. Complex quantifiers

The discussion would not be complete without briefly considering (49a) and the general unavailability of the reading that provides information about the eventuality. Why is the only available reading (49b), which provides information about the quantity of a certain participant, and presupposes the eventuality? This paradigm seems to hold for all sentences involving a quantifier which contains comparison, and therefore also a parameter value, or perhaps more generally, which takes more than two arguments. I refer to such quantifiers as *complex quantifiers*. Complex quantifiers, including *many*, *little* and *few*, all involve at least three arguments. Two of them are simple quantified expressions, one of which is defined with respect to the other. So in all the sentences in (54), the quantity of the Undergoer is defined as greater or smaller than, or equal to some other quantity.

(54) a. John ate many apples.

$$\exists x, y, e, n, X \text{ [[}x \in X \Leftrightarrow [\text{apples}(x) \wedge \text{John}(y) \wedge \text{eat}(e, y, x)]\text{]}_{\text{PRESUPP}} \wedge$$

$$\wedge [\text{norm-number}(\wedge X, n) \wedge \text{max}(|X|) > n]_{\text{ASSERT}}\text{]}^{19}$$

In a presupposed eventuality of John eating something with the property apples, the maximal quantity of the eaten thing is greater than some normal number of apples eaten (by John) for the relevant context.

b. John ate as many apples as pears.

$$\exists x, y, e, z, e_1, X, Z \text{ [[}x \in X \Leftrightarrow [\text{apples}(x) \wedge \text{John}(y) \wedge \text{eat}(e, y, x)]\text{]} \wedge$$

$$\wedge [z \in Z \Leftrightarrow [\text{pears}(z) \wedge \text{eat}(e_1, y, z)]\text{]}_{\text{PRESUPP}} \wedge [\text{max}(X) = \text{max}(Z)]_{\text{ASSERT}}\text{]}^{19}$$

In two presupposed eventualities, one of John eating something with the property apples and the other of John eating something with the property pears, the sets of the two eaten things have the same cardinality.

c. John ate most apples.

$$\exists x, y, e, a, X, Z \text{ [[}x \in X \Leftrightarrow [\text{apples}(x) \wedge \text{John}(y) \wedge \text{eat}(e, y, x)]\text{]}_{\text{PRESUPP}} \wedge$$

$$\wedge [\text{aggreg_number}(\wedge X, a) \wedge \text{max}(|X|) > a * 50\%]_{\text{ASSERT}}\text{]}^{19}$$

In a presupposed eventuality of John eating something with the property apples, the eaten thing counts more than 50% of the apples available in the relevant context to participate in such an eventuality.

This other quantity can be the expected or average number of apples to be eaten as in (54a) for *many*, the quantity of some other object for *as many as* (the number of pears eaten in (54b)), or some aggregate number of apples as in (54c) for *most*. I refer to this second argument (the one with respect to which the quantity of the denotation of the nominal expression is determined) as the *parameter value* (with Westerstahl 1985 and later analyses along the same lines). The third argument is a property, which just as with non-complex quantifiers consists of participation in the eventuality represented by a VP. The most important property of this construction is that it involves a relation between two quantities, that of one of the nominal arguments and the parameter value. Moreover, all these sentences appear to take this relation as their main predicate, the one that is directly picked by the assertive power of the sentence. They all lack the reading in which the other available predication

¹⁹ \wedge stands for the intension of the relevant predicate.

appears as the main predicate, i.e. none of them can be interpreted as asserting that the eventuality took place. In other words, all these sentences can be used to answer the question *How many apples (compared with the parameter value) did John eat?* – corresponding to the three semantic representations in (54), but not the out-of-the-blue question *What happened?* I will refer to these questions as the *How many?* question and the *What happened?* question.

To briefly summarize, a general property of these sentences is that the meaning of each of them involves two different propositions, only one of which can be asserted (taken as the main predicate). The other predication is always presupposed. The presupposed predication is always the one of the eventuality, and the other one, which is asserted, always represents the relation between the quantity of one of the participants and some parameter quantity, which is either contextually provided or overtly represented.

This description, distinguishing between the asserted and the presupposed proposition, is supported by the following facts. Firstly, sentences with more than one complex quantifier only receive paired (proportional) readings. Only one of four possible readings is available for (55) – the one in which it communicates the proportion between the eaters and the thing eaten.

- (55) More than three boys ate less than seven apples.
 $\exists x, y, e, X, Y [[[x \in X \wedge y \in Y] \Leftrightarrow [\text{apples}(x) \wedge \text{boys}(y) \wedge \text{eat}(e, y, x)]]]_{\text{PRESUPP}} \wedge [\max(|X|) < 7 \wedge \max(|Y|) > 3]_{\text{ASSERT}}$
In a presupposed eventuality of boys eating apples, there were more than three boys and less than seven apples.

Secondly, yes-no questions involving complex quantifiers can only receive an affirmative answer if the eventuality is presupposed and, crucially, the quantificational relation holds (56b). The answer is negative when the eventuality is presupposed but the quantificational relation does not hold (56c). Finally, the questions are infelicitous when the eventuality is not presupposed (56d).

- (56) a. Q: Did John eat less than seven apples?
 b. if John ate five apples, positive – A: Yes, he did.
 c. if John ate ten apples, negative – A: No, he didn't. (#A: Yes he did, but more than seven.)
 d. if no eating of apples is presupposed (e.g. John picked five apples), infelicitous – #A: Yes he did, but he PICKED them.

I can only suggest a possible direction for explaining these facts, since space is lacking for a longer discussion in a dissertation concerned with eventualities.

Compare the sentences in (54) with those containing the regular two-place quantifiers in (57). The most striking fact is that both sentences in (57) can provide information about the eventuality, i.e. they can answer the question *What happened?* Yet, they still differ in one respect. The one in (57a) can answer both the *What happened?* question and the *How many?* question. Although there is no relevant parameter value for the reading related to the latter question, nothing prevents us from adding one for the sake of uniformity (e.g. representing it as *John ate three apples compared to some context-determined number of apples*). Having both

readings available, and the parameter being irrelevant (and thus answering the *How many?* question irrespective of this value) is what distinguishes the sentence in (57a) from both the one in (57b) and from those in (54).

- (57) a. John ate three apples.
b. John ate the apple.

The sentence in (57b) represents the third possible pattern of behavior: it can answer the *What happened?* question but not the *How many?* question (at least not as a direct answer that does not cancel the presupposition). With respect to the parameter value, it is closer to the sentences in (54). Due to the maximization of definite nominals, the quantity of the relevant participant (the Undergoer) is entailed to be equal to the parameter quantity, which is the maximal quantity of entities with the relevant property in the context (in this case one apple). The additional information provided by the definite article marks this referent as discourse-old and specific. Ergo, the sentence in (57b) can be paraphrased as: *John ate one single discourse-old apple compared to one single (relevant) discourse-old apple*. It is now clear why (57b) is not a possible answer to the *How many?* question. If only one relevant entity is available in the context, then such a question is either trivial (when the eating eventuality happens to be presupposed as well) or it in fact asks whether or not John has eaten the unique apple (so not really a *How many?* question). It is therefore clear why the definite nominal expression eliminates the reading which answers the *How many?* question: because the answer to this question is presupposed.

An analogous explanation for the problem of the unavailability of the *What happened?* reading for the sentences in (54) would be that their presupposition contains an answer to this question. Quantifiers which involve parameters can only appear in contexts where the parameter is presupposed or where the quantifier position is altogether topical (e.g. when a *How many/much?* question is asked). Consequently, a) no out-of-the-blue question can be asked and b) the quantifier will be interpreted outside the domain of the eventuality, i.e. it will scope higher. The parameter value is therefore responsible both for the absence of the *How many?* reading for the definite article in (57b), and for the absence of the out-of-the-blue *What happened?* reading in the examples in (54). Finally, in most cases, the parameter value is determined with respect to the remainder of the eventuality predicate, and thus this part of the predicate also needs to be presupposed or topical. Potential counterexamples are provided in (58), where the parameter value involves a different eventuality than the relevant one (i.e. the one in the matrix clause). These examples involve more complex structures than quantifiers: there are obviously clausal structures involved, which can be split from the representation of the relevant participant. Nevertheless, they still presuppose a certain relation between the eventuality in the parameter and the one in the matrix clause, which means that they also presuppose the relevant predicate.

- (58) a. John ate more pears than Bill could collect.
b. Jan heeft meer appels GEGETEN dan Peter heeft GEZIEN. Dutch
Jan AUX more apples eaten than Peter AUX seen.
'John ate more apples than Peter saw.'

The important role of the parameter value that this approach stresses supports the view of reference types in the previous subsection, in which tests for cumulativity and divisiveness also involved the parameter value. This again confirms the binary division of reference types into quantized and non-quantized, since the cumulative and divisive ones fully overlap. Yet, even if the proposed explanation for complex quantifiers is not on the right track, primarily important for the view of inner aspect presented in the previous subsection is the empirical observation that, at least at the level of pragmatics, complex quantifiers require the eventuality to be presupposed and the quantity relation to be asserted. This is another confirmation of the different domains of interpretation for eventualities and complex quantifiers.

4.7. Paths, Sources and Goals

In this subsection I reexamine Krifka's (1998) view of the class of eventualities he analyzes in terms of the movement relation. Eventualities involving this relation display the behavior pattern illustrated in (43), and repeated here as (59).

- (59) a. John pushed the cart/carts for an hour/?in an hour.
 b. John pushed the cart from the park to the shop in an hour/?for an hour.
 c. John pushed carts to the shop for an hour/?in an hour.
 d. John pushed the cart (from parks) to shops for an hour/?in an hour.
 e. John hiked for an hour/?in an hour.
 f. John hiked the Vernal Falls path in an hour/?for an hour.
 g. People hiked the Vernal Falls path for five days/in five days.
 h. John heated the water for an hour/?in an hour.
 i. John heated the water to 90 degrees in an hour/?for an hour.

These eventualities require the presence of some additional participants in order to derive telicity. In proper transitive sentences without any additional participants, the thematic role of the Undergoer does not map the reference type of the participant onto that of the eventuality. In (59a), irrespective of the reference type of the Undergoer, the eventuality is atelic. However, introducing certain other participants to such an eventuality can make it telic, as in (59b).

In order to capture this, Krifka introduces the notion of Paths. An eventuality that involves the movement relation has the potential of involving a Path as well. Krifka takes Paths as yet another primitive, a separate type, but one which undergoes the basic mereological relations. He defines three relevant kinds of paths: the corresponding Path of an eventuality (its trace of movement, *Vernal Falls path* in (59f-g)), the Goal (*the shop* in (59b, c)) and the Source (*the park* in (59b)).

The first kind of paths, Paths of eventualities, are simply defined as traces in space corresponding to eventualities of movement. Goals and Sources are defined with respect to the Path of the respective eventuality and its properties. Sources are paths that are adjacent to the Paths of all the initial parts of an eventuality and Goals are adjacent to the Paths of all the final parts of an eventuality (initial and final parts are independently defined). It follows from these definitions that an eventuality that is described involving a Source and a Goal will always be telic. This is derived from the fact that an atelic eventuality can have proper parts that bear the same predicate. Since the predicate of an eventuality that has a Source and a Goal must describe these two components as well, proper parts of such an eventuality sharing its

predicate will also share its Source and its Goal. But a proper part of an eventuality trivially cannot share its both initial and final parts, and hence it also cannot share its Source and Goal. For a formal representation of Paths, Goals and Sources and their effects on telicity in Krifka's account, see Krifka (1998: 26-27).

There are two problems with Krifka's definition of Goals and Sources. As shown in (59d), the reference type of the Source and the Goal can be mapped onto the eventuality: if the Goal or the Source, or both, are cumulative, the eventuality will be cumulative as well. This means that Krifka's definition in which the presence of the Goal makes the eventuality telic is not correct. The Goal, if present, should in fact map its reference type onto the eventuality. Moreover, the effects of introducing a Goal or a Source are even more complex. In (59c), the presence of a Goal changes the behavior of the Undergoer of movement, which can now map its reference type onto the eventuality. The sentence with a bare plural Undergoer is atelic if it also has the Goal participant specified, irrespective of the properties of the Goal. These facts are not new, since Verkuyl designed his model to account for them (see section 3.3).

To some extent, such facts follow in the line of Krifka's general observations about the movement relation, and sometimes they can even be derived directly from a slightly modified definition of Goals and Sources. Krifka uses the quasi-physical properties of movement to explain the special behavior of the eventualities involving this type of relation and introduces restrictions related to discontinuous and circular Paths and to containing parts which are backward with respect to the aggregate movement, and it can be discontinuous and circular.

If each eventuality of movement has a directly corresponding Path, then it is possible to derive the effects of the reference type of the Path onto that of the eventuality, assuming that these effects come from the quantifying component in the predicate of the Path, and that this component also extends to the eventuality. Furthermore, a similar relation could be established between Goals and Paths, to also derive the effects of the reference type of the Goal onto the reference type of the eventuality (the Goal being a path that is adjacent to the Path of the eventuality). In spite of its possible empirical coverage, this approach amounts to having two distinct mechanisms (i.e. mapping and the correspondence described in this paragraph) for a single class of empirical effects that can be described as extending certain referential properties from a participant to the eventuality.

Let us consider some more facts and aspects. The class of eventualities involving the movement relation is in Krifka's view broader than simply the eventualities denoting a physical movement. In fact, it covers all the eventualities which do not (always) map with their Undergoer, but can be made telic by different 'Path' participants. In other words: all the eventualities that involve a process (dynamicity in Verkuyl's terms), but which are atelic with a quantized direct object and no path specified. From the empirical point of view, however, there seems to be a gradation of eventualities with respect to this property. Observe the examples in (60).

- (60) a. John heated the water ?in an hour/for an hour.
 John heated the water to 90 degrees in an hour/*for an hour.
 b. John lengthened the rope ?in an hour/for an hour.
 John lengthened the rope to 10 meters in an hour/*for an hour.

- c. John gobbled the mango in an hour/for an hour.²⁰
John gobbled the mango to the pit in an hour/*for an hour.
- d. John analyzed the problem in an hour/for an hour.
John analyzed the problem to primitives in an hour/*for an hour.
- e. John straightened the rope in an hour/?for an hour.
John straightened the rope to absolute straightness in an hour/*for an hour.
- f. John cleaned the room in an hour/?for an hour.
John cleaned the room to complete sterility in an hour/*for an hour.
- g. John killed Mary in an hour/*for an hour.
*John killed Mary to a terrible death in an hour/for an hour.
- h. John broke the connection in an hour/*for an hour.
??John broke the connection to total isolation in an hour/for an hour.

All of these examples are telic (if well formed) when a quantized Goal is present, but they have different properties of inner aspect when represented without such a Goal. In (60a-b), we have eventualities that involve no physical movement, but which are very similar with respect to their inner aspect to eventualities of movement. In sentences without the Goal, the preferred reading is atelic (although with a contextually specified Goal a telic reading may become available). The next step in the gradation is given in (60c-d), where eventualities without a Goal seem fully ambiguous between the telic and atelic readings; and in (60e-f), the default reading for the eventualities without a Goal is the telic one, although they may still receive an atelic reading if provided with an appropriate context. And finally, the eventualities in (60g-h) are strongly telic without a Goal participant, and ungrammatical when one is introduced.

The represented gradual distribution of eventualities between those typical for Krifka's movement relation in (60a-b) and those that always properly map with the Undergoer as in (60g-h) indicates that the semantic distinction cannot be fully captured by a discrete system of two classes (the eventualities with movement vs. those without it). Furthermore, the notion of a nonphysical movement is quite loose, and can in fact apply to any eventuality that involves dynamicity, i.e. that is compatible with notions such as Goal and Source. This means that the notion of a non-physical movement can apply to all telic eventualities, including the eventualities that always have a proper mapping with the Undergoer (Hay *et al.* 1999 in fact propose an approach to inner aspect based on this generalization). In fact, this latter class, illustrated in (60e-h) seems to include only VPs projected by verbs with resultative meanings, i.e. where the Goal participant is part of the meaning of the verb itself. Some of these verbs even resist an overt realization of the Goal, as shown in (60g-h), indicating the presence of a certain idiomatic component (the incorporated Goal cannot be modified). One possible reason for this is that the Goals in these cases are strictly unique (one death per living being, one breaking per connection). This is however not sufficient, since even in cases where uniqueness is less strongly imposed conceptually, as in (61a-b), overt realization of

²⁰ A number of speakers disagree with this judgment, finding the telic reading of this eventuality (the one with the *in*-phrase) ungrammatical. However, in Ramchand (2002: 11), the author, who is a native speaker of English, considers the relevant interpretation and the corresponding structure fully available.

the Goal for the verb *to kill* is not allowed. This resembles the general property of idioms, especially when they are VPs, that their lower structures (the Goal, the direct object) are likely to be frozen, while the higher domains (Initiators, Instruments) can still vary. This is shown in (61c-d), where grammatical sentences are derived by modifying the higher syntactic domains. It therefore seems to be an idiomatic property of the verbs involved in the descriptions of these eventualities that they have a strong interpretation of one particular incorporated Goal (e.g. in the way suggested by Hale and Keyser 1993). This reading cannot be modified, and it therefore clashes with any attempt to overtly specify a Goal.

- (61) a. *John killed his Tamagotchi to different kinds of death.
 b. *John killed Mary to hell.
 c. John killed his Tamagotchi by different kinds of death.
 d. John killed Mary with a gun.

From this point of view, all eventualities that show mapping involve the movement relation, in the sense that their description may involve some abstract Path and some abstract Goal (the result). For all such eventualities, the presence of this Path or of elements that entail its presence (the Source or the Goal) is required in order to establish the mapping. Sometimes the verb used in the description of an eventuality incorporates the Goal, so the Goal is present in every eventuality described using this verb. It is also possible that a Goal or Source is supplied contextually, which is sufficient to license the mapping. The context can also specify a non-default reference type for the Goal that is incorporated in the verb, leading to a change in the reference type of the eventuality. The major conclusion is that only eventualities with a result component may show effects of mapping of reference types to inner aspect of the eventuality, because only eventuality with a result component can have specified Paths, Goals and Sources. Verbs that incorporate the Goal lexically specify the presence of the result, while other verbs need to have it overtly specified by Path, Goal or Source phrases.

The aspect of Krifka's model discussed here seems in many ways to run parallel to the one that forced Verkuyl (1993) to introduce complex verbs, discussed in section 3 on Verkuyl. Both are supposed to account for the fact that some Undergoers are expected to map, but fail to; both introduce a special tool for eventualities of this kind and both tools are shown to actually apply to a broader class of eventualities than intended. The discussion in this section points the way towards a better solution. I propose that the odd class is not the one in which a Path participant is required to license a mapping between the Undergoer and the eventuality. Rather, I consider the opposite case to be odd, namely the one where mapping of the Undergoer is obligatory, even when the Path is not introduced by a separate constituent. This obligatory mapping appears to be a consequence of having the Goal incorporated in the verb used to describe the eventuality. Incorporated Goals often tend to receive a very strong or even idiomatic interpretation.

4.8. Summary

Krifka proposes a mereological model of the properties relevant for the relation between the inner aspect of the eventuality and the nominal expressions that represent its participants. The central notion in his account is the distinction between

quantized and cumulative reference types, i.e. the capacity of predicates to extend to parts or sums of entities for which they hold.

Assigned to the event argument, quantized predicates yield telic eventualities, and cumulative predicates atelic ones. The reference type of the eventuality is sensitive to that of its participants, and this is captured by the notion of mapping. This notion forms part of the meaning of certain thematic roles, usually assigned to the direct object. Roles involving this property map between the reference type of their nominal arguments and that of their event arguments. Mapping can go both ways.

Source and Goal roles are defined with respect to the Path of the eventuality, and they are presented as having the same structure (i.e. being of the same type) as Paths. In Krifka's view, only some of the verbs involving mapping have Paths. He relates this property to the movement component contained in their denotation. Verbs of movement do not map their Undergoers, and they may take Sources and Goals. Having a Source and a Goal will make the eventuality telic.

One of the problems that Krifka faces relates to predicates like *more than six apples*, *few students* or *a quantity of water*. These predicates are non-quantized, but they still derive telic eventualities when they appear with a thematic role that involves mapping. Krifka suggests that these predicates always (partly) scope over the VP, and thus escape mapping.

Based on the provided definitions, cumulative and quantized predicates do not cover all the possible predicates in natural language. In fact, a third type, labeled divisiveness, has been defined in the literature (Krifka 1992, Filip1997), and it covers all the non-cumulative non-quantized predicates. I have presented a possible view on how these three properties can be tested, in which cumulative and divisive predicates fully overlap, so that all predicates can be divided into two reference types: quantized and non-quantized. If this turns out to be the case, the different notions of divisiveness and cumulativity would only relate to the entailment of the quantifier involved in the predicate, but not directly to the inner aspect. Some facts introduced in the next section provide further support for this view.

Discussing Krifka's model, I pointed out that the mere presence of Goals and Sources does not make eventualities telic, but these participants map their reference type onto that of the eventuality and license mapping between the Undergoer and the eventuality. I suggest that the mapping between Goals/Sources and the eventuality is indirect, occurring through the Path of the eventuality they determine. Therefore, the presence of the Path, whether it is directly or indirectly determined, not only maps the Path to the eventuality, but it also allows the reference type of the Undergoer to be mapped to that of the eventuality. Finally, I have shown that the distinction among the eventualities that involve mapping, between those with the movement relation and those without it, is not as discrete as Krifka suggests. A gradation is presented from verbs which require a Path to derive telicity to those which are incompatible with Paths. I suggested that certain verbs incorporate their Goals (results), and that the degree to which an eventuality is independent of an overt specification of a Path, Goal or Source directly corresponds to how rigidly its incorporated Goal is interpreted. This rigidity reflects the extent to which the verb is idiomatized. Most importantly, this view suggests that there are two distinct notions of telicity, one related to the presence of the result component, whether overtly specified or incorporated in the verb, and the other related to the reference type of

the eventuality, resulting from different mappings, involving different participants. The latter type of inner aspect is strictly conditioned by the former, i.e. mapping occurs iff the eventuality involves a result component. This observation receives further elaboration, and explanation, in Chapter III.

5. A syntactic approach to eventualities: Borer (2005b)

5.1. Introduction

The two approaches to eventualities that I presented and discussed so far, the one by Verkuyl (1972, 1993) and the one by Krifka (1992, 1998), are both oriented towards the semantic rather than the syntactic properties of eventualities. The two approaches differ, since Verkuyl's approach takes eventualities to be composed from different smaller units, such as lexical verbs and participants. An eventuality is hence a compositional structure, and its properties, including inner aspect, are derived from this structure. Krifka, on the other hand, takes eventualities to be primitives, which means that they are not directly built from other units, and that their properties are determined in some other way. For Krifka, an eventuality is represented through the event argument, which receives interpretation from a predicate in which it appears. Part of this interpretation is its inner aspect, which can be specified lexically (e.g. by a Goal, Source or Path phrase), or mapped by a thematic role from some suitable participant. Nevertheless, both these approaches assign an important role to the lexical verb which heads the VP representing the eventuality. For Verkuyl, this verb can either have or lack the feature of dynamicity ([+/-ADD TO]). For Krifka, the verb determines whether it assigns thematic roles that involve mapping (and possibly also uniqueness). In both cases, a property of the verb licenses the mapping between the eventuality and the corresponding participants. Verkuyl (1972) already observed that this brings in a certain asymmetry. While the contribution of the nominal expressions (denoting the participants) to the eventuality comes from the properties of the determiner, which is a functional element, the contribution associated with the VP itself comes from the verb, an essentially lexical element.

Before proceeding, I would like to briefly introduce the terms *functional* and *lexical*. The term *lexical* denotes the material in the meaning of a sentence that is contributed by the so-called 'open class' lexical elements such as nouns and verbs. This lexical material only has conceptual content, and is irrelevant for syntax. The term *functional* relates to all the elements in language that have a certain direct relevance for syntax. In fact, every piece of any structure in syntax should be linked to some functional material. This functional material relates the structure to the actual phenomena in language that it represents. Functional elements of narrow syntax can (or must) have other types of properties as well: they can bear a meaning, have phonological content or relate to pragmatic notions. These non-syntactic properties are irrelevant for narrow syntax, but they become important once syntax is related to the actual domain of the non-syntactic property. For the purposes of this discussion, the most relevant such relation is the one between syntax and semantics.

When nominal arguments are concerned, their relevant feature (Verkuyl's [+/-SQA] or Krifka's reference type) figures at the level of NP, and not of a lexical noun. It is usually determined by functional elements such as grammatical number

and quantification. In this view, it is problematic that the corresponding functional feature in the verbal domain (Verkuyl's [+/-ADD TO] or Krifka's thematic roles that map reference types) be contributed by the verb, which is a lexical element.

The asymmetry between verbs and nominal expressions can also be viewed from another angle, which stresses the problem more clearly. The representation of a syntactic structure is supposed to include all the elements that are directly relevant to this structure. All such elements are by definition functional. However, the [+/-ADD TO] property, or the corresponding thematic role, is uncontroversially relevant to inner aspect, which is also a syntactic phenomenon. Therefore, by definition, these two elements must be seen as functional. The compromise which must be reached is to present the lexical entries of verbs as associated to some functional material (and therefore also to some syntactic structure). An important disadvantage of such an approach is that it involves syntax in the lexicon, which blurs the modular organization of grammar. Nevertheless, this way of dealing with the interface between syntax and the lexicon is quite popular among linguists (from entire frameworks such as LFG, to individual linguists such as Levin 1993, Reinhart 2002, Hale & Keyser 1993 etc.). A theoretically more desirable solution would be to keep the boundaries between modules clean. In such an approach, the lexical verb would need to be split from the functional features associated with it. While the verb would reside in the lexicon, unspecified for any syntactic properties, the functional features would reside in the structure in which the verb can be attached. A radical approach along these lines is taken in Borer (2005b).

5.2. To eventualities through syntax

Over the past twenty years, a number of linguists, among others Rosen (1984), Tenny (1994), Travis (1994), Ramchand (2002) and Gehrke (2005a), have developed accounts of phenomena related to eventualities in terms that emphasize the important role of syntactic relations. Within this type of accounts, a place of honor is reserved for the work of Hagit Borer, starting with her (1994) paper. In Borer (2005b), she provides a broad and complete picture of her theory of syntax, including its applications to different problems of event structure and a great variety of empirical phenomena that shed new light on many aspects of the field. The main points of this theory are presented in this section.²¹ Hagit Borer develops a theory of both VPs and NPs at the syntax-semantics interface. In this section, I concentrate on the part related to the VP.

At some points, I am forced to provide a slightly simplified picture of Borer's theory, to keep the level of the presentation accessible or to avoid theory-specific notions such as movement or bare phrase structure, with which a part of the readership of this dissertation may not be familiar.

The account that Borer proposes is not decompositional: she assumes no internal semantic organization of the eventuality in which components such as process or result have a particular place. Borer derives the predicate of the eventuality from a closed and universal set of functional features together with a number of arguments. Furthermore, she does not assume any mereological mapping between the predicate

²¹ Unless otherwise indicated, all references in this chapter to Borer's work refer to the (2005b) monograph.

of the eventuality and its participants. In her approach, parts of eventualities and parts of participants do not correspond to each other in any interesting way. The only relation established between the predicate of the eventuality and the arguments that take part in its composition is feature assignment. In her opinion, this interaction is therefore extremely shallow and fully determined by syntax.

Borer's account is particularly explicit and principled in distinguishing the functional and lexical domains in syntax. She attempts to isolate all the material that is not directly relevant to syntax in order to precisely represent all the elements that are undoubtedly functional. She develops a model for the (lower sections of) the functional structure of the NP and the VP, which, among other things, derive properties corresponding to Krifka's (1992, 1998) reference types. In this model, the VP and the NP have almost identical structures.

Like Krifka, Borer allots an important role to mereological properties such as quantization and cumulativity. She does not refer to them as reference types, but as properties related to *quantity* (a term carrying a specific meaning that becomes clear by the end of the section). This is, however, a mainly terminological difference, since ways of establishing reference and Borer's quantity are in fact two sides of one and the same property. In Borer's model, quantity-properties receive their structural realization immediately above the lexical material of the expression. This is shown in (62), where all the projections related to quantity are underlined.

(62) General structure and corresponding projections in NP and VP (Borer 2005b)

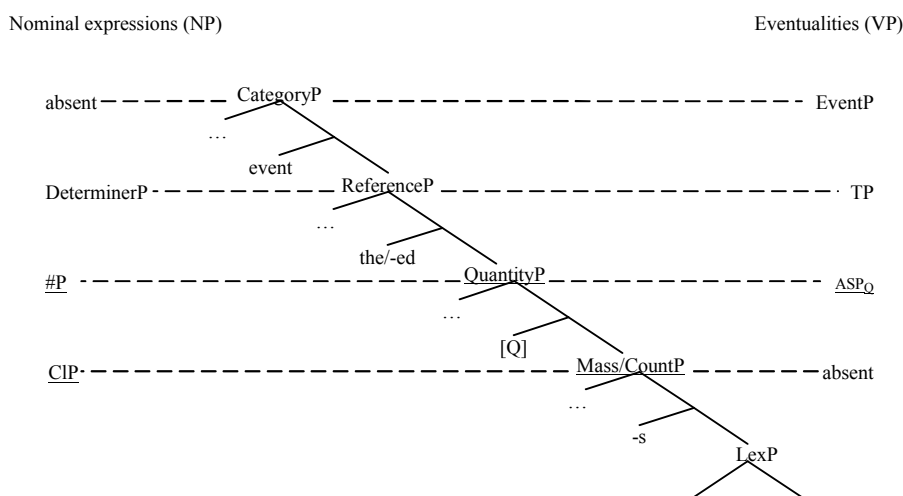

In the nominal domain, two phrases are directly related to quantity properties: the Classifier Phrase (CIP) and the one that Borer marks as the #Phrase (#P). The #P is where quantifiers and similar predicates are derived, and it closes off the specification of quantity properties in NPs. In the domain of eventualities, there is only one phrase responsible for quantity properties, and therefore also for inner

aspect: the Aspectual Quantity Phrase (ASP_Q).²² This phrase closely corresponds to the nominal #P. The lack of a projection corresponding to CIP in the verbal domain is an asymmetry that disturbs the full parallel between the two domains. The task of the syntactic structure above the quantity properties is to establish reference and mark the category. For eventualities, it also generates two arguments. One is the Initiator, for which Borer uses the term *Originator* (generated in the specifier of the TP, short for *Tense Phrase*). The other is the event argument, introduced in the highest projection, marked as EventP. The event argument represents the eventuality and takes the entire lower structure as its predicate. I mainly focus on the part of the structure related to quantity properties, and only briefly discuss the higher structure, since it is less closely related to inner aspect and argument structure, which form the main topic of this chapter.

The structure of an eventuality looks roughly as in (63). Compared to the general structure in (62), the main difference is that the head of the ASP_Q is filled with an element marked as [α], instead of the earlier [Q]. For the moment, [α] can be seen as a variant of [Q] appearing in the VP (a counterpart to the [#] feature characteristic for the NP). It specifies a range that can be assigned to the open value of the quantificational type in the ASP_Q.

(63) Preliminary version of Borer's representation of the VP

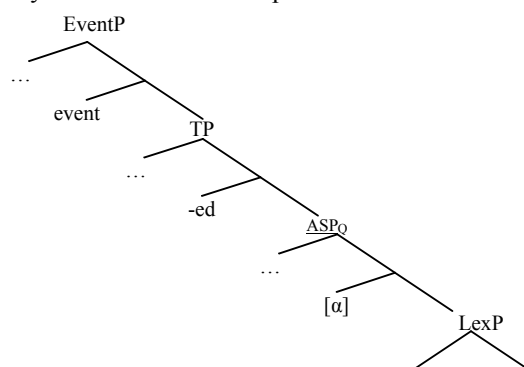

Finally, an important assumption of Borer's theory is that the head of each projection is originally derived without any features, but simply with an open value. This open value is only marked for category, and represents the bare capacity to take a particular value from the range of values available for the respective category. The particular features are either attached immediately above the head (if it is lexicalized by a separate morpheme, for which Borer uses the term *functional morph*), or they are contained in the phrase that appears in the specifier of this head. In both cases, the feature that c-commands the head assigns a range of values to the open value that this head contains. With this modification, the structure looks as in (64), where <e> stands for an open value, and the index marks the category of the phrase, which at the same time determines the range and type of the value to be assigned.

²² In fact, Borer posits one additional projection between the ASP_Q and the lexical domain, and calls it FP. This phrase is considered inactive with respect to the reference type, so I leave it aside for the moment.

(64) Borer's full template of VP structure

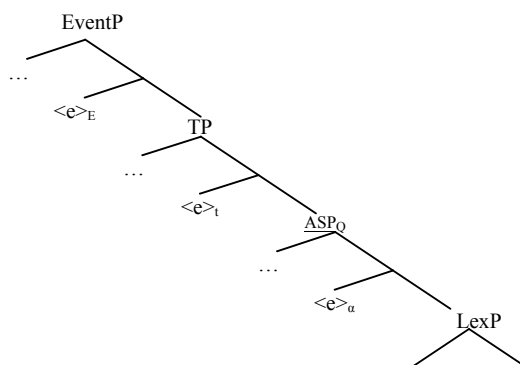

Since dealing with open values and range assigning complicates our view of this model, and does not play any significant part in the topics that I discuss, I take the simplified structure in (63) as the basis of further discussion. I therefore assume that functional features and the morphemes that lexicalize them are generated in the heads of their respective phrases.

Borer takes the described structure as a generally available pattern, in which a closed set of possible configurations can occur. The particular configuration in which an eventuality is derived does not depend in any way on the verb or any other lexical unit. With respect to grammar, every verb, or in fact every lexical (non-functional) morpheme can appear in any well-formed structure. Apparent regularities in the appearance of certain lexical units in certain categories, which are traditionally reflected in different classes of lexical units, are a matter of pragmatics rather than grammar. This view is part of Borer's general constructionist approach to grammar, which deserves a short excursion at this point.

Constructionist approaches to grammar are those where an important role is given to form-meaning pairings in grammar. In these approaches, structure is largely independent of lexical units, i.e. it is independently available, together with corresponding interpretations. Normally, these interpretations can only be further specified, by a number of possible lexical units which fill the positions in the structure that are not fixed. For a more detailed picture of Construction Grammar, see for instance Goldberg (1995).

In her view of language, Borer views the lexicon as a mere list of units containing no information which is significant for grammar. She calls these units *listemes*. Formally, a LexP headed by a certain listeme can project any possible category, independent of its conceptual meaning. The category then imposes a certain interpretation, to which the conceptual contents carried by the listeme must adapt. This process of accommodation, which is essentially pragmatic, is sometimes very difficult or impossible to achieve. In such cases, the expression appears to be degraded. Crucially, for Borer this degradation is purely pragmatic, and is in no way related to the grammaticality of the projected structure.

Borer gives the following examples in the domain of eventualities. Many verbs may appear with different argument structures, as in (65a-b) or with different aspectual properties, as in (65c-d).

- (65) a. John dropped the apple.
 b. The apple dropped.
 c. John pushed the cart for ten minutes/?in ten minutes.
 d. John pushed the button in ten minutes/?for ten minutes.

For Borer, the unacceptability of examples such as (66) is not a matter of syntax: they are syntactically perfectly well-formed. These examples are blocked by the failure of pragmatics to form a sensible interpretation involving the elements imposed by the syntactic structure.

- (66) a. #John sang Mary.
 b. #John found.

Therefore, for Borer, every possible syntactic structure is (a substructure of) a pattern, taken from a relatively small set of possible patterns, and with all patterns obeying certain universal syntactic constraints. It is these patterns that form the locus of syntactic research, and not any aspect related to the lexicon. From the point of view of syntax, the lexicon is a list of units which are fully unmarked, unordered, and therefore essentially all the same. What I refer to as patterns is largely parallel to what is called constructions in various constructionist approaches, with the difference that in Borer's system constructions are more prominently related to a set of universal syntactic constraints.

Now we can come back to Borer's syntactic account for eventualities. Transferring Krifka's (1992) position from semantics to syntax, Borer assumes atelic eventualities to be unmarked and telic ones marked. More precisely, telic eventualities are derived only when the relevant phrase, the ASP_Q , is projected and assigned the relevant feature $[\alpha]$.²³ Borer assumes that the projection of a phrase requires that its head be assigned at least one relevant feature (relevant meaning related to the kind of meaning that the projection represents), or, in her terms, that the open value is assigned some range. Therefore, when ASP_Q , the structure is only grammatical if it contains the feature $[\alpha]$. There are three ways for this feature to be introduced in a proper structural relation with the relevant head. Two of them are presented in (67), and the third is presented below in (68).

- (67) a. Feature in the head

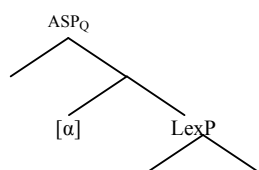

- b. Feature in the specifier

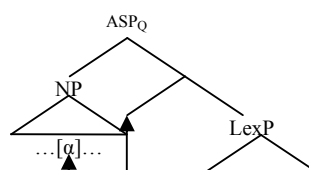

In (67a), a functional morpheme that contains feature $[\alpha]$ is generated in the head of ASP_Q . The head and the entire projection are thus licensed and make the eventuality represented telic.

²³ It should be clear at this point that α stands for 'aspect'. In fact, it marks the presence of a quantity predicate, as will become clear in the remainder of this section, and this quantity predicate corresponds to telicity.

In (67b), the specifier of ASP_Q contains the feature $[\alpha]$. If the specifier of ASP_Q is a quantified nominal expression, i.e. its functional structure contains a $\#P$, a specifier-head relation is established between this nominal expression and the head of ASP_Q . Borer assumes, together with a number of syntacticians (beginning with Chomsky 1991), that this relation triggers *specifier-head agreement*. The two positions, the head and the specifier of ASP_Q , must agree in the relevant feature. Recall that in (62), $\#P$ corresponded semantically to ASP_Q , which means that their relevant features, the feature of quantity in $\#P$ and $[\alpha]$ in ASP_Q , are the counterparts of each other in the NP and VP domain. Since the specifier of ASP_Q contains the counterpart of the feature $[\alpha]$, due to agreement, feature $[\alpha]$ also appears in the head of ASP_Q . If the NP in the specifier of ASP_Q did not contain $\#P$, the $[\alpha]$ feature could not be assigned.

Borer interprets the structural accusative case as an overt reflex of the agreement in ASP_Q . It is assigned to the NP representing the Undergoer if this NP happens to appear in the specifier of ASP_Q . Borer calls such an Undergoer the *subject of quantity*, because it appears in the specifier position of the projection within the VP domain that is related to quantity.

The agreement described above predicts the following scenario. If, like in (67a), feature $[\alpha]$ appears only in the head of ASP_Q , but not in its specifier, the NP in the specifier has to also be assigned the $[\alpha]$ feature by the same kind of specifier-head agreement. Borer suggests that this indeed happens in languages with overt marking of aspect (again, this is a syntactic reformulation of Krifka's position on this issue). The aspectual markers, generated in the head of ASP_Q , contain the feature $[\alpha]$. The specifier of this projection is assigned the corresponding feature by the specifier-head agreement mechanism. Borer provides examples from Warlpiri, Haisla and Slavic languages, which all use aspectual morphemes, to support this claim.

Finally, if neither the head nor the specifier of the ASP_Q provide the relevant feature, it is still possible for some element containing the feature to attach to the structure as an adjunct (for instance an adjunct of quantification such as *three times*). This element modifies the c-commanded structure to include the ASP_Q , the head of which can then be assigned the relevant feature. The tree in (68) illustrates this configuration.

(68) Third possibility: the feature comes from an adjunct

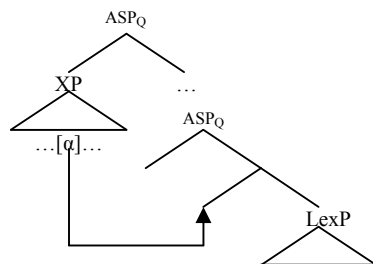

Borer exemplifies this way of assigning the feature $[\alpha]$ with goal phrases, which she calls event delimiters, as in (69).

- (69) a. John pushed the cart to the shop.
b. John walked into the room.

In her analysis, PPs *to the shop* and *into the room* are generated in an adjunct position on top of ASP_Q. These PPs can assign the feature [α] to the head of ASP_Q, yielding telic eventualities.

Borer derives the semantic properties of inner aspect and argument structure from the syntactic properties of the structure in which they are derived. For instance, as many other projections, ASP_Q does not necessarily have to be projected. If this phrase is not projected, irrespective of the availability of the feature [α] elsewhere in the structure, the eventuality that is projected is atelic. Thus the telicity of an eventuality depends on whether the relevant phrase is projected and whether there is a way of assigning it the feature [α]. This means that, irrespective of the lexical properties of the verb, there are always two types of structures in which a verb can appear, the telic ones and the atelic ones.

Borer's feature [α] is mereological in nature and to some extent parallel to Krifka's quantization and Verkuyl's [+SQA] (some differences are presented below). The crucial innovation of Borer's model concerns the mechanism 'copying' this feature from nominal expressions to eventualities and the other way around. Both Krifka and Verkuyl offer semantic accounts for this relation and define it as involving parts of eventualities and parts of the denotation of nominal expressions. For Borer, no such background is required (it is even explicitly denied, as shown below). In her model, the interaction between the two types of units is a consequence of the syntactic relation between them. Observe the examples in (70).

- (70) a. John ate apples.
 b. John ate the apple.
 c. John pushed the cart.
 d. John pushed the button.
 e. John pushed the cart to the shop.

The sentence in (70a) is atelic because it has no argument with the feature [α] to assign it to the head of ASP_Q (the Initiator, here *John*, is not a good candidate, since it is, in Borer's view, generated too high to have effects on ASP_Q). The sentence in (70b) is telic because it does have such an argument, and because ASP_Q is projected. The requirement that the head of the ASP_Q be filled will result in having an adequate argument in the specifier of the ASP_Q and it will trigger agreement between the two positions. An atelic structure is available for (70b) as well, because the projection of ASP_Q is optional. Borer's position is that this sentence does have an atelic reading, but it is strongly dispreferred, mostly for pragmatic reasons.

The sentence in (70c) provides the inverse case: it favors the atelic structure, i.e. not projecting the ASP_Q, but a telic one is available as well. The same verb and the same quantity on the direct object can still derive a VP with a preferred telic reading, as in (70d). In both cases, it is pragmatic knowledge which leads to favoring one or the other interpretation.

Finally, the telic structure for (70c) becomes much more natural when a Goal modifier is provided which assigns the feature [α]. This could be due to the fact that the Goal is pragmatically a better assigner of the feature [α] than the particular Undergoer in the example. The Goal PP attaches in a position from which it can assign a feature to the head of the ASP_Q. Note that, for such a mechanism to make sense, Borer is forced to assume that the Undergoer in (70c, e) fails to receive proper

accusative case. If it did, it would be required to bear the $[\alpha]$ feature, and assign it to the head of the ASP_Q . For (70c), this would result in a telic reading (perhaps like in pushing a button), and for (70e), the PP would become irrelevant (which is in fact not an impossible option). Borer suggests that in sentences such as these, the argument surfacing as the direct object does not bear the structural accusative case, but is underlyingly a PP, with the preposition being somehow dropped.

I can now complete the picture and introduce the structure above the ASP_Q . This structure consists of two phrases, the TP and the EventP (EP). The TP is projected immediately above the ASP_Q , if present, or, in its absence – above the next lower phrase (the lexical phrase or FP, which is introduced in (71c)). TP is responsible for the interpretation of tense, and its specifier position is where the participant with the role of Originator (the Initiator in the representations in Chapter I) is generated. This follows a long syntactic tradition of relating the nominative argument to the tense of the clause, based on the agreement between the tensed verb and the nominative argument present in most languages with the categories nominative and tense. EP is projected above the TP, and its only function is to introduce the event argument. The event argument is therefore generated on top of this structure, as the head of the EP, and it takes the rest of the structure as its predicate. The entire structure is shown for three examples in (71).

(71) Full structure corresponding to an eventuality

a. John painted the wall.²⁴

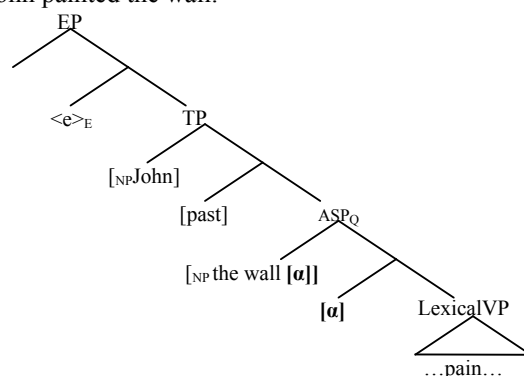

b. John painted at the wall.

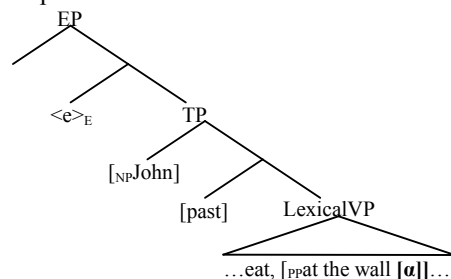

²⁴ I reintroduce the open value marking ($\langle e \rangle$) for the EP because there is no 'event feature' to replace it.

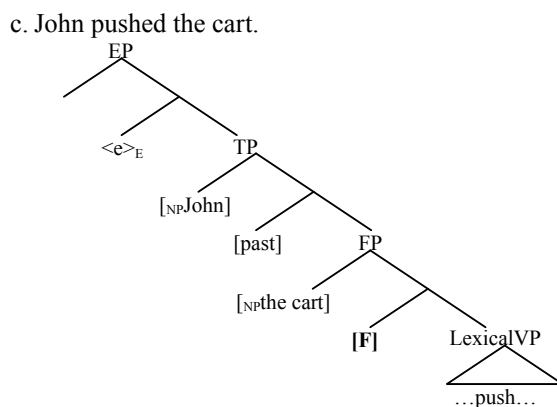

The eventuality in (71a) is telic, because it projects the ASP_Q and has an argument with the feature $[\alpha]$ in the specifier of the ASP_Q which assigns a value to its head. The same lexical material (or, in the spirit of Borer, the *conceptual array*: unstructured conceptual material from which the sentence is generated) can derive an atelic structure if the ASP_Q does not project. In the opposite case, if ASP_Q projects but there is no argument bearing the feature $[\alpha]$, no grammatical structure can be derived.

Atelic structures can be derived in two ways. One is simply to omit the ASP_Q , in which case there is at most one structural argument (the nominative subject), and all other participants are represented by PPs, as in (71b). The other way to generate an atelic structure is to postulate a functional projection FP instead of the ASP_Q , which generates a structural argument and assigns the correct category to the predicate to which the event argument is introduced. However, this phrase does not assign the $[\alpha]$ feature, and its structural argument can therefore not receive (proper) accusative case.²⁵ This is shown in (71c).

This view, in which the effects of different arguments on telicity are captured in terms of syntax rather than semantics, has one important consequence for the semantic side of the problem. The mechanism in which Undergoers, Sources, Goals and possibly other participants can make an event telic is strictly structural. It has no relation to the semantic structure of the event: it is independent of any decomposition that determines the telos or termination, as well as of any mereological mappings such as those in Verkuyl's and Krifka's work. The only interesting relation between eventualities and their participants that relates to mereological notions is the assignment of the relevant feature to the relevant functional projection. It is now time to say something about the mereological nature of the feature $[\alpha]$ which is the central component of this assignment relation.

5.3. Telicity as non-homogeneity: advantages and problems

Borer uses mereological properties similar to those defined in Krifka (1992, 1998) to define her feature $[\alpha]$, which is responsible for telicity. However, she argues for a slightly different correspondence between what Krifka calls types of reference and

²⁵ Borer supports the argument that case in these structures is not really accusative with examples from Finnish, where the Undergoer of atelic eventualities is assigned morphological partitive case.

the telicity on the VP. Krifka only uses the properties *cumulative* and *quantized*, corresponding closely to atelic and telic eventualities, respectively.²⁶ Borer, on the other hand, includes the property *divisive* (building on the work of Moltmann 1991 and Kiparsky 1998), in order to build the diamond-shaped structure in (72). Predicates in her view have two independent properties [+/-cumulative] and [+/-divisive] (a non-divisive non-cumulative property being also referred to as *quantized* and a divisive cumulative property as *homogeneous*).

(72) Four combinations of cumulativity and divisiveness

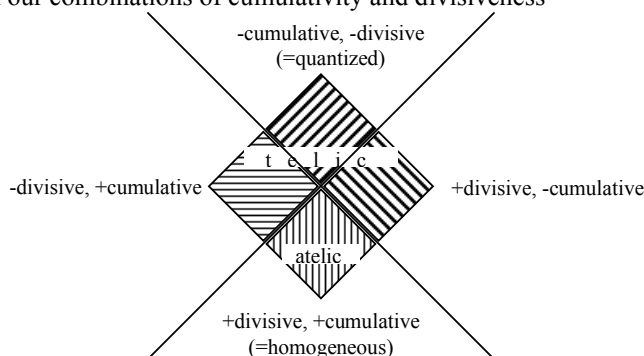

Borer argues that all atelic eventualities have homogeneous predicates. In other words, it is not necessary that a predicate is quantized for a telic eventuality: only non-divisiveness, or only non-cumulativity, is sufficient. This mereological definition of telicity is weaker than the one proposed in Krifka (1992), where quantization (of the predicate or of the temporal interval of the eventuality) was required. In the spirit of her model, she draws this view from the syntactic structure. In Borer's model, the predicate of an eventuality is always atelic by itself, requiring the presence of the ASP_Q to make it telic. In other words, it is derived by default without any specification of quantity (which would make it non-divisive and/or non-cumulative), and it is therefore interpreted as homogeneous. A predicate can be specified for quantity only if the structure in which it is derived, projects the ASP_Q . The ASP_Q is therefore present whenever a predicate is marked for at least one of the two properties that introduce non-homogeneity: non-divisiveness and non-cumulativity. Borer's model predicts that it is sufficient to have one of these two properties to derive a telic eventuality, because these two properties are marked in the ASP_Q and the mere presence of the ASP_Q is sufficient to derive a telic eventuality. Since the structure is well-formed whenever any feature is assigned to the ASP_Q , even one of these features will satisfy the condition and license the presence of the ASP_Q in the structure of the VP. Borer thus claims that the correct empirical observation is that divisive non-cumulative and cumulative non-divisive predicates derive telic eventualities. She provides examples such as (73) to show that nominal expressions bearing these properties can indeed derive telic eventualities.

²⁶ Eventualities with cumulative predicates can be telic if their temporal intervals are quantized. Moreover, iterative and circular eventualities can have quantized predicates and be atelic in Krifka's definition of atelicity. These two cases are not central to the current discussion.

- (73) a. John ate more than three sandwiches in ten minutes/?for ten minutes.
 b. John ate some sandwiches in ten minutes/?for ten minutes.
 c. John ate less than seven sandwiches in ten minutes/?for ten minutes.

This view is another component of Borer's theory which follows naturally from her syntax. As already mentioned, she identifies two phrases which are responsible for the quantity properties of a nominal expression. These two phrases, the CIP and the #P, are projected immediately above the lexical domain of the nominal expression, as shown in (74).

- (74) Borer's structure of the nominal expression *the three sandwiches*

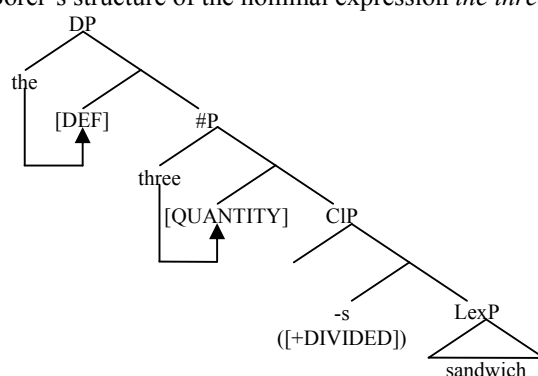

The CIP corresponds to the category of grammatical number. The structure on top of which this phrase projects (LexP) has no marking for quantity properties and it is interpreted as an unstructured, unspecified quantity (usually referred to as *mass*, as in *sugar*, *water*, *power*). Once the CIP is projected, its head must be assigned a feature, and in this way the predicate is specified as being *divided*, deriving the meaning of mass division. Borer defines mass division as an infinite set of possible divisions over a mass entity. The structure of a nominal expression that only has a CIP corresponds to a bare plural (this is natural, since the plural marking is generated in this phrase). Bare plurals thus denote unbounded sets of individual divisions, so that even though they do not denote a mass, they still have a homogeneous denotation. The head of the #P, if present, specifies this meaning for a proper quantity. This head is assigned a value by quantificational elements such as cardinals and quantifiers. Since the #P specifies quantity, it is always also [-divisive], [-cumulative], or both, i.e. it excludes homogeneity.

Since the relevant nominal expressions in (73) all contain elements of the #P nature, they all project a structure that involves both the CIP and the #P, with certain features in the head positions. In other words, none of these expressions can, in Borer's terms, be homogeneous. Hence, in English (where the head of the ASP_Q starts out empty and must get a feature from the specifier), they can be subjects of quantity and derive telic eventualities. Therefore, basing her approach more strongly in syntax, Borer predicts that non-quantized eventualities without bounded temporal intervals will exhibit telicity, which was surprising in Krifka's theory.

One direct problem for this approach is that with the definitions offered so far, the predicate *some apples* in (73b) appears homogeneous. In order to make her approach work, Borer proposes a more subtle definition of divisiveness, as in (75).

$$(75) \text{ divisive: } \forall P. [\text{DIV}(P) \Leftrightarrow [[\forall x. P(x) \Rightarrow \exists y. P(y) \wedge y < x] \wedge [\forall x, y. P(x) \wedge P(y) \wedge y < x \Rightarrow P(x-y)]]];$$

A predicate P is divisive iff when it holds for an entity x, there is at least one part of that entity y for which the predicate also holds, and when P holds for x and its part y, it also holds for the complement of y with respect to x.

Note that, going back to the discussion in section 4.4, this definition relates to the set-theoretic notion of downward entailment just as the definition of cumulativeness relates to the notion of upward entailment.

$$(76) \text{ a. } \forall P. \text{DIV}(P) \Leftrightarrow [\forall x, x'. \quad x' < x \quad \wedge P(x) \wedge P(x-x') \Rightarrow P(x'); \\ \text{a}'. \forall Q. \downarrow(Q) \Leftrightarrow [\forall X, X', Y. \quad X' \subseteq X \quad \wedge Q(X, Y) \quad \Rightarrow Q(X', Y)]. \\ \text{b. } \forall P. \text{CUM}(P) \Leftrightarrow [\forall x, z. \quad P(x) \wedge P(z) \Rightarrow P(x \oplus z)]; \\ \text{b}'. \forall Q. \uparrow(Q) \Leftrightarrow [\forall X, Y, Z. \quad Q(X, Y) \quad \Rightarrow Q((X \cup Z), Y)].$$

This is illustrated in (76), which is a modification of (47) from 4.4 with the new definition of divisiveness. Upward entailment for a predicate requires that if it holds for a certain set, it also holds for each union of this set with other sets. This parallels cumulativeness in its requirement that if a predicate holds for some entity, it should also hold for its sums with other objects. But not for all such sums, because cumulativeness, in addition, requires that the other member of the sum also satisfies the same predicate. Borer adds an analogous requirement to the definition of divisiveness: the difference between the whole and any of its parts that satisfies the same predicate as the whole, also must satisfy that predicate.

Two properties distinguish between divisive and cumulative predicates. The first is that the former allow for maximal objects for a certain predicate, i.e. objects that satisfy the predicate but do not undergo sums with other objects satisfying the same predicate, or they do undergo such sums, but the resulting objects do not have to satisfy the relevant predicate. Such objects are excluded by the definition of cumulative predicates. The second is that cumulative predicates allow for minimal objects, which cannot be divided, or which can be divided, but only so that if one part resulting from the division satisfies the relevant predicate, its complement does not. This kind of objects is excluded for divisive predicates.

Borer argues that according to the new definition of divisiveness, the predicate *some apples* is not divisive. Borer argues that this predicate is not satisfied by objects that do not involve more than one individual apple. Therefore, if we divide some object that satisfies this predicate, for instance five apples, so that one part counts four apples and the other counts one apple, the latter part will not satisfy the predicate *some apples* because it will not be more than one. This means that according to Borer's definition of divisiveness, the quantifier *some*, like any other quantifier, bounds the predicate. In Borer's view, bare plurals represent unbounded sets of possible divisions over the mass denoted by the lexical noun (i.e. parts smaller than one individual unit of counting also satisfy the predicate of a bare plural

nominal), and therefore they are divisive. Note that if *some* indeed leads to non-divisiveness, the parallel between cumulativity and upward entailment, and between divisiveness and downward entailment, is strengthened. Before Borer's adjustment of the definition of divisiveness, *some*, which is clearly upward entailing, was both divisive and cumulative.

Borer gives a number of other examples supporting the claim that a predicate which is only divisive or only cumulative can still assign the feature [a] to its eventuality. Among them, only those involving the quantifier *some* are not complex quantifiers in the sense discussed in 4.5 and 4.6. The conclusion reached in these two sections supported Krifka's suggestion that quantifiers of NPs with divisive non-cumulative or cumulative non-divisive predicates scope much higher than the VP. Arguments that these NPs introduce are interpreted as variables, and therefore quantized. Mapping the reference type of these arguments onto the eventuality makes the eventuality telic. This is why the quantifier *some* is particularly important for the presented view of the mereological properties of predicates. Unlike complex quantifiers, *some* has a weak form. Weak quantifiers have the property that they do not form their interpretation independently of the eventuality in which they participate. In other words, weak quantifiers appear to scope inside VP or at least not very high outside the VP domain. Therefore, Krifka's argument that was supported by the discussion in 4.5 and 4.6 cannot hold in this case.

As (77) shows, predicates involving the weak *some* (Borer writes it as *sm*, to mark the fact that it is destressed) can give rise to telic eventualities.²⁷ This means that, just as Borer predicts, they are not homogeneous. The argument, as Borer notes herself, depends on the assumption that the weak quantifier not only scopes low and near the ASP₀, but that it does not have wider scope than this projection.

(77) John ate sm apples in half an hour.

Borer gives one more type of example to show that cumulative eventualities and divisive eventualities can be telic as long as they are non-homogeneous. These are examples in which the mereological nature of the eventuality itself, and not of the relevant participant, is argued to be non-homogeneous. Examples of this kind are illustrated in (78).

- (78) a. John ran to the store.
 b. The ship sank (to the bottom of the ocean).
 c. Pat walked home.

Borer argues that all these eventualities have one property in common with respect to Krifka's (1992, 1998) model: they are non-quantized. Yet, they are all obviously telic. The problem clearly has to do with the one already observed in 4.7, i.e. with the way Krifka defines the role of Goal. However, even if this particular definition of Goal is ignored, and the eventualities of the three sentences are simply tested for quantization, they appear to be non-quantized. This is due to the fact that there is a part of the running to the store which is still running to the store. This holds for any part of the big eventuality which starts after the beginning of the big eventuality and

²⁷ Another advantage of using the weak *sm* is that it only has the quantificational interpretation and not the one related to the discourse-specificity of the participant as in *I am looking for some student...*

goes on to its end. Of course, eventualities of this kind are not cumulative, since two eventualities of going to the store cannot be summed up into one eventuality of going to the store. Observe however that these eventualities are not quantized only if Krifka's definition of quantization is considered. If Borer's definition is applied, they are in fact non-divisive. Even if part of the eventuality of running to the store can still satisfy the predicate *running to the store*, the difference between the whole and the part in this case will not satisfy the predicate of running to the store, since it will only cover an initial part of this eventuality. Being non-divisive and non-cumulative makes an eventuality quantized.

5.4. Some problems and debatable aspects of Borer's approach

In 4.7 I discussed the following problem in Krifka's (1992, 1998) account. Krifka defines Sources and Goals as participants that delimit the eventuality by their very presence, and not as mapping participants which delimit only if quantized. I used examples such as (79) to show that in fact the presence of a Goal participant only licenses mapping, which appears to involve both the Goal/Source/Path and the Undergoer (the subject of quantity for Borer). Therefore, the non-quantized quantity of the Goal in (79a) and of the Undergoer in (79b) make the eventuality atelic in these two sentences. If these two participants are both introduced by quantized predicates, the eventuality is telic, as in (79c).

- (79) a. John pushed the cart to shops for ten hours/?in ten hours.
 b. John pushed carts to the shop for ten hours/?in ten hours.
 c. John pushed the cart to the shop in ten hours/?for ten hours.

Borer's model allows for the Goal participant to appear in a position from which it assigns the $[\alpha]$ feature to the head of the ASP_Q . In fact, in its narrowest definition, it allows this type of assignment for any participant that can be base-generated lower than or within the ASP_Q projection.²⁸ In her chapter 16, Borer distinguishes between proper assigners of the feature $[\alpha]$ and adjuncts which only modify the meaning of the ASP_Q . Implicitly, this means that the set of modifiers that can adjoin to the ASP_Q is restricted as well. In this way, Borer is able to account for more or less all the data she considers. However, although the data is accounted for, this move remains unattractive since it boils down to either stipulating that the ASP_Q does not project, or to stipulating that it does. This kind of account cannot capture a number of regularities which appear in this domain.

One instance of such regularity is related to verbs of the type presented in (79) (Krifka 1998's verbs involving movement relation, such as *to push*, *to move*, *to heat*, *to lengthen*). When an eventuality is described using one of these verbs and without a Goal participant, it is never assigned the $[\alpha]$ feature by the Undergoer. The ASP_Q , however, always projects if the Goal participant is introduced and able to assign the feature $[\alpha]$ (i.e. if it is not homogeneous). In Borer's terms, the projection of the

²⁸ Here I discuss only the adjuncts that are clearly related to aspectual structure: Paths, Goals and Sources. However, note that Borer's model leaves open the possibility that any other participant realized as an adjunct, if it contains the feature $[\alpha]$, can in fact adjoin to ASP_Q and assign to it the feature $[\alpha]$. Borer tries to prevent this by assuming that only certain adjuncts are marked as being able to modify ASP_Q . However, she does not explicitly say how this marking occurs, and I do not see any obvious way in which this can be formally done.

ASP_Q directly depends on the presence of a Goal, Source or Path participant. Borer tries to solve this by distinguishing between adjuncts that are range-assigners, able to assign the feature [α], and adjuncts that are only predicate modifiers, triggering projection of ASP_Q, but unable to assign the feature. This solution does not explain the empirical facts, but rather stipulates them.

There are in fact important additional regularities that make the problem more complicated for Borer's model. One is that even when with both a Goal and an Undergoer present, if only one of them is non-homogeneous, the eventuality is atelic (exactly what (79a-b) shows). This means that even if there is a candidate for assigning the [α] feature to the ASP_Q, the presence of a participant that has no [α] feature blocks the projection of the phrase and the feature assignment. The general problem is that Borer's approach predicts that one non-homogeneous participant should be sufficient to yield a telic eventuality. The generalization seems to be the reverse: one homogeneous participant is sufficient to derive an atelic eventuality. Therefore, Verkuyl's (1972) 'leaking points' metaphor seems more appropriate.²⁹

The behavior of Paths is similar to that of Goals, except that they can even appear as structural arguments. Take for instance the unaccusative eventualities in (80). If both the Undergoer (here surfacing as the subject) and the Path (the direct object) are non-homogeneous, the eventuality is telic. But if one of them is homogeneous, as in (80b-c), the eventuality can only be atelic, in spite of the availability of a non-homogeneous participant, expected to be able to assign the [α] feature.

- (80) a. A boy hiked the Vernal Falls path in an hour/?for an hour.
 b. A boy hiked short paths for ten days/?in ten days.
 c. Boys hiked the Vernal Falls path for an hour/?in an hour.

The behavior of Sources is somewhat different. The difference lies in the fact that they do not tend to appear in sentences without a Goal participant. This is shown in (81a). Once a Goal is present, Sources behave just like Goals and Paths. All three participants now need to bear the [α] feature in order to derive a telic eventuality. If one of them is homogeneous, irrespective of the status of the other two, the eventuality will be atelic. This is a problem both for Krifka and for Borer.

- (81) a. ?John pushed the cart from the house.³⁰
 b. John pushed the cart from the house to the shop in ten hours/?for ten hours.
 c. John pushed the cart from houses to the shop for ten hours/?in ten hours.
 d. John pushed carts from the house to the shop for ten hours/?in ten hours.

²⁹ This suggests that Borer's system might be inadequate. A possible alternative would be that dynamic eventualities are by default telic. Only a homogeneous participant can assign the relevant feature and change the aspect of such an eventuality. If there are only non-homogeneous arguments, the event remains telic. If no arguments are given, it may happen that the Undergoer or the Path is interpreted as dropped (a phonologically null argument). Such an argument would have mass interpretation since it lacks any functional projection (including #P), and it will again make the eventuality atelic. The problem with this alternative is that empirically, telic eventualities seem, on a regular basis, to have their subjects of quantity in the specifier of ASP_Q, and to assign to them accusative case.

³⁰ Judgments are quite mixed with respect to this type of sentences. Still, the number of cases in which all speakers recognize a contrast is quite large. Exceptions appear mostly with verbs that incorporate Goals (which makes them fit the solution I propose in this section and in Chapter III). See Gehrke (2005a) for a more detailed discussion of this problem.

Let me now propose a different view that offers a nice account for the observed phenomena. Recall that Krifka proposes that Goals and Sources are belong to the general type paths. In the light of this proposal, the illustrated irregularity in behavior displayed by Sources may hint to a simple explanation. When simultaneously present, the Source and the Goal actually determine the Path (as a path-element that connects them). If either the beginning of the Path (the Source) or its end (the Goal) has homogeneous reference, the Path will be homogeneous as well. Ergo, if we assume that Paths ‘map’ to eventualities, just like Undergoers, we can neatly cover the behavior of Paths, Goals and Sources. In Borer’s model, this might perhaps be implemented by generating Goals and Sources within the phrase representing the Path. Whenever it appears that the feature [α] is assigned by the Goal or the Source, it is in fact embedded within a Path phrase which it determines.

Indeed, Goal and Source participants behave as if they are generated within the participant receiving the role of the Path. It has been observed, most explicitly in Rothstein (2003), that a single eventuality can take at most one participant for each of the roles. When two different constituents have the same role, one of them must be a part of the other. Example (82a), where one of the two Direction/Goal phrases introduces a proper part of the other, is perfectly acceptable. The same holds for (82c), where temporal adverbials are in the same relation. But the sentences in (82b, d) are bad because their doubled modifiers are not in a part-whole relation. Note that the intended meanings are not nonsensical. John’s trip could have two consecutive phases, one where he goes to Holland and another where he continues to Denmark, or he could have worked in Leiden both in 1994 and in 1995. See Rothstein (2003) for a discussion of multiple modifiers of the same property.

- (82) a. John travelled to Holland, to Amsterdam.
 b. *John travelled to Holland, to Denmark.
 c. John worked in Leiden in the year 1994, in November.
 d. *John worked in Leiden in the year 1994, (in the year) 1995.

The same generalization holds for Goals, Sources and Paths. If in a single clause the Path is specified on a par with the Goal and/or the Source, the Goal and the Source must be interpreted as parts (of the specification) of the Path. This is illustrated in (83) (another variation on Krifka’s 1998 examples).

- (83) a. John hiked the Vernal Falls path to the second last curve.
 b. John hiked the Vernal Falls path from its beginning to the last curve.
 c. John hiked the Vernal Falls path from the second curve.
 d. (?/#)John hiked from the second last curve of the Vernal Falls path.

The Goal in (83a, b) (the second last curve) and the Source in (83b, c) must be interpreted as parts of the Path (the Vernal Falls path). The presence of the Path in (83c), just as the Goal in (83b), licenses the overt realization of the Source participant. The condition for this seems to be that the Path may not be embedded in the expression realizing the Source. This is shown in (83d), where the Path is present, but appears as a complement of the Source. This sentence is not perfectly acceptable, just like any sentence that only has a Source but no Goal or Path, unless of course a Goal or a particular bounded portion of the Path is clearly provided by the context.

The conclusion is therefore that Goals and Sources are closely related to the Paths and that they together belong to the specification of one participant role. A natural representation for this is to take the Goal and the Source as complements of the Path. As a result, it is reasonable to expect that the presence of these two participants entails the presence of a Path. This offers a different point of view concerning the question of why Sources require the presence of a Path or Goal to be overtly specified. This is due to the fact that by itself, a Source cannot determine the Path. In fact, an analogous requirement holds for Goals as well. The question therefore becomes why Goals can appear without Paths or Sources. I would like to suggest that in fact they do not. Rather, whenever the Goal is specified, the Source figures in the interpretation as well. If it is not overt, it can be inferred from the context. Sources are just more easily inferred from the context than Goals. Goals can also be contextually provided, as shown by the acceptability of (83d) under the condition that the context strongly specifies either the Goal or the Path of the movement. Sources are more frequently contextually determined because the process (change, movement) denoted by an eventuality normally starts from the last relevant state assigned to the Initiator or the Undergoer in the discourse. Goals, on the other hand, are usually new in the discourse, introduced by the clause built on the eventuality, and are therefore less frequently available in the context. Clauses with a Source and without a Goal or Path place even heavier demands on the context, and are therefore degraded with respect to analogous cases with a Goal participant. For additional discussion on this point, see Chapter III.

Note that in this view, eventualities that only contain a Goal, like Borer's example in (78) and my own (79c) are undoubtedly quantized. When contextually given information is included, they are specified for both the Goal and the Source. Clearly, no proper part of running from a contextually determined point to the shop will preserve the full predicate (involving the same Source and the same Goal). Verbs in Serbo-Croatian (S-C) confirm this view. The telic description of the eventuality in (84a) can only be used if the Source is clearly determined by the context. The one in (84b), which is atelic, does not require contextually given Sources, but derives either iterative or progressive readings.

- (84) a. Jovan je od/pre/za/iz-plivao do obale *(za) jedan
 Jovan AUX from/over/for/out-swim to coast.GEN in³¹ one
 sat. S-C
 hour

‘Jovan swam to the coast in an hour/*for an hour.’

Paraphrase 1: Jovan started from a previously known place and swam to the coast.

Paraphrase 2: *Jovan was already swimming (towards the coast), and then there was a part of this eventuality from some point within this path and to its end, which I want to describe.

³¹ In Serbo-Croatian, the preposition *za* most closely corresponds to the English *for*. Yet, in its temporal use, it derives the adverbial that indicates telicity, just like the *in*-phrase. For that reason, when used in the tests, I gloss it as *in*. The adverbial without any preposition corresponds to the English *for*-phrase.

b. Jovan je plivao do obale (za) jedan sat.
 Jovan AUX swim to coast.GEN in one hour
 ‘Jovan was swimming to the coast for an hour/in an hour.’

Paraphrase 1: Jovan iteratively swam to the coast, starting from a previously known place (or places).

Paraphrase 2: *Jovan iteratively swam to the coast, starting from different unknown places, possibly parts of other paths to the coast.

Paraphrase 3: Jovan was swimming to the coast, after having started from a previously known place.

Paraphrase 4: Jovan was swimming to the coast, after having started from possibly unknown places, which could be parts of bigger paths to the coast.

The example in (84a) shows that it is only possible to use a telic description for an eventuality that involves movement if the Source is determined, whether overtly or by the context.³² The imperfective variant in (84b) allows for both iterative and progressive readings. The iterative reading presents a repetition of a telic eventuality, and it therefore also requires a specified Source (or Sources), which makes a non-specific source unacceptable. The progressive, on the other hand, presents a part of an eventuality as a state, and as such it has no requirements on the Source participant.

The second type of eventuality that Borer presents as non-quantized telic is given in (85), and it deserves a separate discussion.

(85) We filled the room with smoke in ten minutes/?for ten minutes.

Eventualities of this type (Borer also lists eventualities such as cooking an egg and writing a sequence of numbers) have the common property that they can be continued after any definable point of completion. Whatever we defined as the concentration of smoke that needs to be reached to have a room full of smoke, after it has been reached we can still keep on filling the room with smoke. From this point of view, the eventuality is not bounded, but it still manifests telicity. Borer takes this as another argument for the fact that non-homogeneity suffices for telicity.

There is one problem with this reasoning. Having a particular level of concentration at which the room is full with smoke does not seem to be the way that this eventuality is conceptualized. The property that makes this eventuality special is precisely the fact that unlike with filling a box with sand, there is no point at which no more smoke can get in. The point of completion for this description therefore seems to vary, and to correspond, for any particular eventuality that is described, to the actual concentration established in this eventuality. Once this description is used for an eventuality, it is irrelevant whether in reality the concentration can be increased or whether the eventuality of the additional increase also can be described with the same expression. The conclusion in (82) can be formulated.

(86) The point of completion of an eventuality depends on the conceptualization of the eventuality rather than any physical properties of the reality that it

³² When determined by the context, the Source usually presents some common location of the relevant participant, its last location specified in the discourse, or the location of one of the interlocutors.

Paraphrase 1: Jovan continued (and completed) filling the room with smoke in an hour/?for an hour.

Paraphrase 2: *Jovan started pumping in the smoke when the room was empty and after an hour it was full.

Paraphrase 3: The room already had an amount of smoke, and Jovan pumped in more until some point (possibly until it was full, in which case both the volume and the concentration reading are equally available).

c. Jovan je iz-pekao tortu *(za) jedan sat.
 Jovan AUX out-baked tart.ACC in one hour
 ‘Jovan baked a tart in an hour/*for an hour.’

Paraphrase 1: Jovan started baking a piece of dough and the result of baking was a tart.

Paraphrase 2: *The tart was already baked (to some extent) and Jovan baked it some more to completion.

d. Jovan je do-pekao tortu. (za) jedan sat
 Jovan AUX to-baked tart.ACC in one hour
 ‘Jovan continued (and completed) baking a tart in an hour/for an hour.’

Paraphrase 1: *Jovan started baking a piece of dough and the result of baking was a tart.

Paraphrase 2: The tart was already baked (to some extent) and Jovan baked it some more (possibly to completion).

Observe in particular, that despite the prefix, an atelic reading seems to be available in the examples (87b, d). This is a rare exception for the Serbo-Croatian aspectual system, in which all prefixed verbs are telic unless an imperfective morpheme is added. It seems, in fact, that the temporal adverbial used for testing is interpreted more as a measure of baking or the smoke pumped. Therefore, its role of a temporal adverbial that tests telicity is at least questioned (see also footnote 33 and the discussion of the for-phrases in Chapter III).

In any case, the observations presented in this section lead to the conclusion that, contra Borer, even if non-homogeneous NPs can assign telicity to the eventuality, an eventuality must be quantized to be telic. This is particularly strong in the light of the view of Goals and Sources proposed here. This observation points to the general tendency of non-homogeneous eventualities to be quantized, rather than somewhere between homogeneity and quantization. Therefore, it provides support for the view presented in 4.5, that there are in fact no non-homogeneous non-quantized predicates in natural language.

A more general conclusion is that certain data can be analyzed much better if a decompositional model is used and semantics is more directly involved.

5.5. Assignment, distribution, quantification

A common question seems to undermine the results of the two approaches based on the mereological properties which are presented here, the one by Borer and the one by Krifka (1992, 1998). This question concerns the relation between, on the one hand, the mapping argued for by Krifka and the range assignment used in Borer’s model, and on the other hand, a number of well-known and relatively well-explored phenomena relating to quantification. In both these approaches, something transfers

from one type of expressions to another, and it is in both cases directly related to quantification. At the same time, both categories normally taking part in this transfer, NPs and VPs, can be directly quantified. As Borer shows, overt quantification over the VP also has a certain effect on inner aspect. Therefore, answers are required, but not explicitly provided, to the following questions:

Do the operations of mapping and range assignment map only the properties of quantizedness, i.e. non-homogeneity, or do they map the entire quantificational component?

Are these operations different from distributive interpretations (interpreting the quantity of one expression as dependent on the quantity of another one)?³⁴

Do they operate only at the level of the eventuality, or also extend to the level of outer aspect and reference time?

What is their precise relation to the temporal structure of the clause, in view of the fact that their major relevance for grammar seems to be their interaction with outer aspect?

Some of these questions are specific to the two mereological approaches discussed here, while others are relevant for any theory of eventualities. A number of possible answers are provided in the remainder of this chapter, as well as in Chapter III.

5.6. Summary

Borer, with a number of other linguists, contributes an important component to the theory of event structure. She observes that some problems related to eventualities can be explained in terms of syntactic structure, and not (only) through semantic considerations. Borer takes this line of reason to its extreme and proposes a fully syntactic account for the major phenomena related to VPs. She argues that the interaction between the inner aspect of an eventuality and its participants is not due to some mapping between their mereological structures. Rather, she presents it as a consequence of agreement in one feature, established between the relevant participant and the head of the projection responsible for aspect. This agreement is triggered by syntactic structure, more precisely, by a specifier-head relation and the requirement that the aspectual head be assigned a feature. Agreement is related to the aspectual feature [α], which establishes a relation with the head of the aspectual projection ASP_Q (i.e. assigns a range to it). There are four theoretically possible situations with respect to this agreement. One is that both agreeing elements have the feature [α], which simply leads to a telic interpretation of the eventuality. Secondly, only the specifier has the feature [α], in which case the head is assigned this feature as well, leading again to a telic interpretation. The third is that only the head has the feature, in which case the feature is assigned to the specifier as well. Apart from deriving telicity, this restricts the quantificational component of the interpretation of the specifier. Finally, the fourth situation occurs when neither element has the feature [α], which leads to ungrammaticality for the following reason. The ASP_Q , if projected, requires a feature [α] in its head, and an argument appears in the specifier of ASP_Q only to assign this feature. But if the argument does not have the feature [α], its appearance in this position will not be licensed.

³⁴ This point has in fact already been treated in Jackendoff (1996) and Ramchand (2002).

Borer specifies that the feature $[\alpha]$ corresponds to the mereological notion of non-homogeneity (rather than to quantizedness, as proposed by Krifka 1992, 1998), which in turn corresponds to the aspectual value of telicity. The ASP_Q is projected optionally: without it, the structure is still well-formed (unless of course its presence is morphologically marked). One of Borer's major points concerns the fact that the ASP_Q , which is responsible for aspect, determines the VP predicate properties in relation to quantity. If this projection is absent, the predicate is interpreted as mass, i.e. atelic. If it is present, its head must be assigned some material, which will to some extent specify the quantity of the predicate. Minimally, this involves specifying the predicate as non-homogeneous.

Borer argues that an eventuality is telic iff its predicate is non-homogeneous. Every NP specified for quantity (i.e. with a non-empty $\#P$) is non-homogeneous, and able to assign this property to the eventuality in which it participates. Only mass nouns and bare plurals fall within her definition of homogeneity, while any other NP is non-homogeneous.

In section 5.5, I pointed out the following drawbacks of this account. It specifies two types of syntactic element that can assign the feature $[\alpha]$ to the eventuality. One is the direct object, usually realizing the Undergoer, which attaches to the specifier position of the ASP_Q . The other can be a particle, a Goal, Source or Path modifier, or a quantificational meaning (like *twice*), as long as it adjoins to the ASP_Q . However, in eventualities involving more than one syntactic candidate for the assignment of the feature $[\alpha]$, an unexpected regularity is observed. If one of the candidates lacks the relevant feature, the telic interpretation is never derived. It appears that the presence of one homogeneous participant blocks the projection of the ASP_Q , which is not what we expect if one or more of the other candidates bear the required feature $[\alpha]$. This observation does not in itself contradict Borer's theory, since the projection of the ASP_Q is optional irrespective of the type of available participants. This is exactly how Borer tries to explain this phenomenon. She distinguishes between real range assigners (real assigners of the feature $[\alpha]$) and the modifiers of the ASP_Q . The latter do not assign the feature $[\alpha]$ and do not require the ASP_Q to be projected, but when present, they can modify its interpretation. However, this weakens the entire theory, signaling that something additional is required for a full account of the observed phenomena. In particular, it indicates that effects of Paths, Sources and Goals are not fully covered by Borer's view of the quantity properties. A decompositional account for eventualities which explicitly treats Goals and Results, combined with the syntactic account, appears to cover a wider range of empirical problems.

This leads to a more general point about Borer's theory. Being so radically based in syntax, it runs into two problems. One is that the theory explains a reduced set of phenomena, without an elaborated interface with theories that can account for the rest. It therefore does not provide an explanation for a number of regularities that are a part of the field of investigation. These regard particular questions like the one discussed above, or more general ones such as, for instance, why it is precisely (non-)homogeneity that matters for aspect, why the ASP_Q is optional, why the Originator has this interpretation etc. Many such questions can be answered if the two sides of the problem, the syntactic and the semantic one, are more strongly related. Compared with the purely syntactic model, a combined syntactic and semantic account involving decomposition provides important advantages, e.g. in accounting

for the behavior of Path participants. This will become even more apparent when I discuss some more general questions in Chapter III, but also in the next approach to eventualities that I present here. The model developed in Ramchand (2002) attempts to combine semantic decomposition with syntactic structure in accounting for the properties and relations of inner aspect and argument structure.

In both Borer's and Krifka's (1992, 1998) mereological approaches, the relation between regular quantification, if possible at all for eventualities, and the operations of mapping or range assignment remains unclear. Moreover, these approaches are not explicit about the interaction between inner and outer aspect, i.e. between the mereological properties of eventualities and reference time.

6. Syntax of decomposition: Ramchand (2002)

6.1. Introduction

In Chapter I, I introduced a simple pattern of decomposition for eventualities as well as its representation represent at the interface between syntax and semantics. This representation was shown to capture a number of phenomena related to argument structure, as well as the aspectual classes proposed by Vendler (1957). Chapter II, so far, has mostly been concerned with the effects of quantificational properties of arguments on the inner aspect of the eventuality. We started out with Verkuyl, who represents eventualities as complex structures of the verb and its arguments. Then we went on to Krifka, who takes eventualities to be a separate semantic type and represents them making use of event-arguments. This account preserves a certain level of decomposition through its definition of thematic roles and the phenomenon of mapping. Finally, Borer's model, which is purely syntactic, entirely denies the role of decompositional semantics in the domain of inner aspect. The major aspects of Borer's model are supported by very strong arguments, which signal that certain aspects of the traditional decompositional view on eventualities are problematic. However, I tried to show that radically denying the role that (de)composition can play in the theory of eventualities is too strong a position. Finally, in this section, I present another recent syntactic approach, which gives decomposition an important role in accounting for the behavior of eventualities at the syntax-semantics interface. In Ramchand's (2002) approach, a very intuitive decomposition of eventualities is developed, in combination with a straightforward syntactic realization.

Ramchand builds her model around two important generalizations. One is the old Aristotelian intuition that telic eventualities appear when two ingredients are combined: a process and a result. The other is the problem that has consistently appeared in all three preceding subsections: the fact that two classes of eventualities can be observed with respect to the role of the Undergoer. In one type, a certain property of the Undergoer ([+/-SQA], reference type, quantity) determines the inner aspect of the eventuality, and in the other type, there is no such determination. The third important aspect of Ramchand's approach is reminiscent of Borer (2005b): she attempts to reduce the semantic side of the problem to only those elements that are syntactically active. In this way, the syntactic representation of the eventuality is in a one-to-one correspondence with its semantic counterpart. The rest must be added in some other way. However, an important difference between the two approaches is that Ramchand does not deny the role of the lexicon: in her model, lexical units are

supplied with specifications of their categorial and selectional properties. Categorial properties restrict the set of possible phrases in which the lexical unit can appear and be interpreted. Selectional properties specify the range of combinations with other lexical and semantic elements that the unit may enter into.

6.2. The tripartite decomposition

Ramchand develops a syntactic decompositional model of eventualities. She assigns an ontological pattern to eventualities, which reflects both their semantic decomposition and their syntactic representation (88). The ontology consists of the initiating subevent, the process subevent and the result subevent, which always combine in the given order. Each subevent is determined by its own features (bearing the meanings of initiating, process and result), which are represented in the heads of the corresponding phrases in (88). The three phrases realizing the three components of the ontology are marked as aspectual, because together they derive the aspectual structure of the eventuality. They might as well have been called argument phrases, since each of them has the capacity of generating one structural argument of the VP.

(88) Ramchand’s syntactic decompositional model of eventualities
vP- Asp,P (aspectual causing projection)

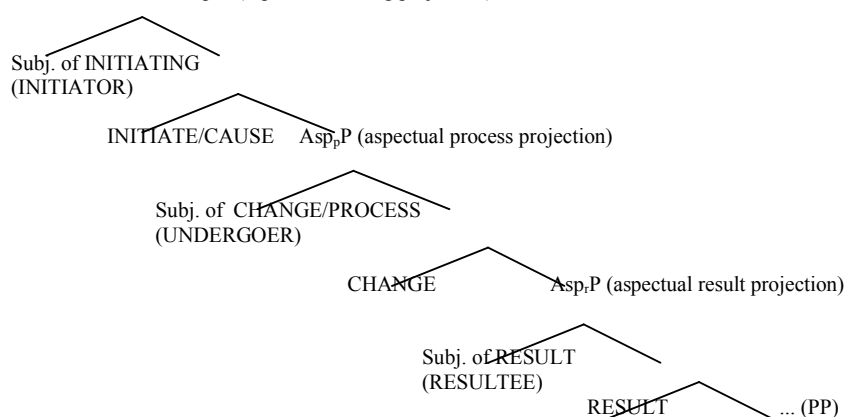

The same tripartite decomposition of eventualities can be represented in non-syntactic terms, as in (89).

(89) A schematic representation of Ramchand’s general ontology of eventualities.

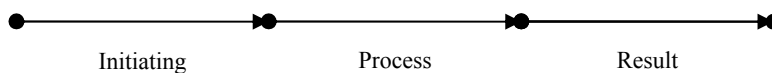

An eventuality is built from at most three elements, which always appear in a fixed order. These elements are called subevents and they come in three types, the Initiating, Process and Result subevent. As explained below, it is not required for all three of these subevents to always have contents. Each subevent can take a subject

and a predicate, and while each of the subjects can surface as a separate structural argument, each of the predicates incorporates into the lexical verb.

The pattern in (88) and (89) presents the maximal structure for the derivation of an eventuality. In its full realization, it corresponds to a telic eventuality. In the derivation of a VP, some of its parts may be omitted, in which case different types of argument structure can be derived, as well as telic or atelic eventualities. Before I return to this in more detail, I first present the basic correspondence between this structure and argument structure.

Ramchand refers to the three components of the pattern as *subevents*. This should not be confused with Krifka's mereological notions in which any part of an eventuality (corresponding to a part of the temporal interval of the eventuality) can be seen as its subevent. Rather, Ramchand's subevents form the building blocks of an eventuality. They are specified for the semantic component that they contribute to the eventuality, which further determines the structural argument that they generate. This follows from the fact that the structural argument contributed by a subevent is generated as the subject of the subevent (i.e. the subject of the semantic component that it contributes). The subject of the initiating subevent is the *Initiator*, the subject of the process subevent is the *Undergoer* and the subject of the result is the *Resultee*. Ramchand therefore has a subject of initiation, a subject of change, or process, and a subject of result. The three arguments are generated in the specifier positions of their respective subevent phrases. This is also illustrated in (88).

It is important to point out that Ramchand proposes this structure only for non-stative eventualities. In her theory, states form a different type altogether, i.e. a unit of lower complexity. As mentioned above, when lexicalized with all its three aspectual projections, the structure always represents a telic eventuality. This is to be expected, since the structure itself is built on the basis of the observation that the simultaneous presence of a process and a result in the same eventuality leads to telicity. Consequently, atelic eventualities should emerge in structures which do not involve both these components. Drawing a parallel with the structure of a syllable, Ramchand postulates the principle that the process subevent cannot be omitted (just as the nucleus of a syllable must be present for something to be a syllable). She presents the other two subevents as states related to the process, one initiating it and the other resulting from it. Ergo, it is the process subevent that introduces a new type into the system, distinguishing non-stative eventualities from stative ones. Together with the two related states, it builds a larger structure. Without the process subevent, all that can be derived is a simple state. Since the process subevent is obligatory, the only way to derive an atelic VP in the structure in (88) is to omit the result subevent. This is shown in (90).

(90) Structure of an atelic non-stative eventuality

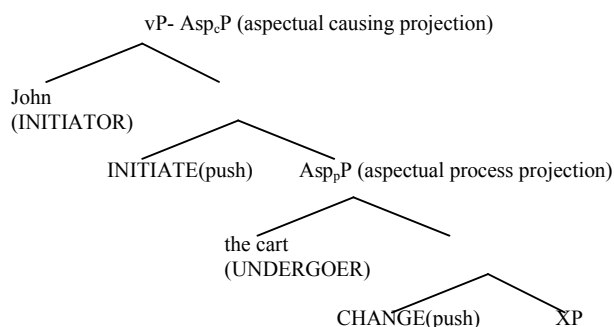

Although it is atelic and has no result, this structure can be both transitive and intransitive. It is transitive when the Undergoer is overtly specified, and it is intransitive if this argument is omitted. In spite of the omission of the phonological realization of its argument, the process subevent is still interpreted. In both cases, this structure falls within Vendler's (1967) aspectual class of activities. Note also that with respect to its aspectual properties, the transitive variant of this structure covers the class of verbs that is problematic for all the approaches presented above. Thus the example in (91a), which gives one such eventuality, is straightforwardly accounted for in the structure in (90). The result subevent is missing, and *the cart* is only the subject of process. Thus, no telos is present in the eventuality and it is naturally atelic. Once the telos is explicitly introduced, as in (91b), or contextually favored, as in (91c), the eventuality becomes telic. This is due to the fact that the presence of the telos in these two sentences requires the full pattern to be properly represented.

- (91) a. John pushed the cart for ten minutes/?in ten minutes.
 b. John pushed the cart to the shop in ten minutes/*for ten minutes.
 c. John pushed the button in ten minutes/*for ten minutes. (non-iterative)

With respect to argument structure, the configuration in (90) derives either a transitive or an unergative VP. The former appears if the subjects of both subevents are overtly specified, and the latter if the Undergoer is not specified, or if it is identical with the Initiator. The model in fact predicts two more options. One is that only the Initiator is omitted, leading to something like an atelic unaccusative. The other is that both structural arguments are omitted, which derives a structure without any overt structural argument. Ramchand suggests that the former option is realized in eventualities that denote a change of state or location without a final value and have only one argument, as illustrated in (92a). Under the condition that expletives are taken to be free of any conceptual contents relevant for eventuality, sentences such as (92b) can represent eventualities that contain the process subevent, but have no overt structural arguments.

- (92) a. The stone rolled (downwards) for seven minutes/?in seven minutes.
 b. It rained for seven minutes/?in seven minutes.
 c. The vase broke in a second/?for a second.

Parallel to the structure in which only the result is omitted, and using the option mentioned earlier of omitting the initiating subevent, we can derive the remaining third partial realization of the pattern. This is shown in (93), which is the structure of telic unaccusative eventualities such as the one in (92c).

(93) Structure of telic unaccusative eventualities

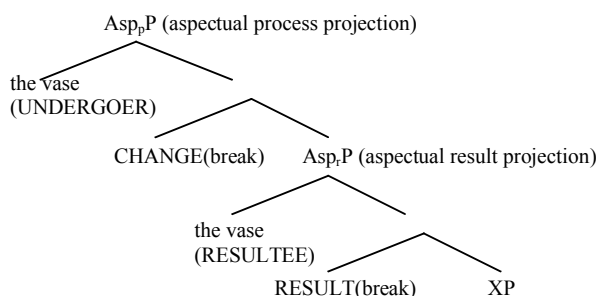

In Ramchand's model, the effects of the quantity properties of the Undergoer are clearly reduced to the result subevent alone. Without this subevent, no telicity is possible at all, no matter what the properties of the participants are. Therefore, the Undergoers immune to the effects of mapping, such as the one in (91a), are generated in the process subevent, as Undergoers. The introduction of a Goal participant narrows down the possible structures: only the structure with a result subevent is adequate, and the effects of mapping are therefore no longer optional. This captures the facts without resorting to an entirely different structure for non-mapping eventualities. Therefore Ramchand's model accounts for the problem of Undergoers that do not map their reference type onto that of the eventuality (see the discussions in 3.3 and 4.7) in a way that is simpler than those proposed in Verkuyl (1972) and Krifka (1998). In addition, the main problem of Verkuyl's and Krifka's approach resided in the fact that the special structure each proposed for the dynamic eventualities that do not map with their Undergoers appeared to be required for a much bigger class than the one that they targeted. Since Ramchand does not introduce new structural components only for the verbs with non-mapping Undergoers, she avoids this problem as well. Technically, Ramchand's solution is quite similar to Borer's (2005) model: they both add an additional projection to handle the non-mapping Undergoers. However, while Borer's FP is simply syntactically stipulated – Ramchand's Asp_pP has a semantic background as well.

With respect to the problem of the interaction between the participants and the eventuality, Ramchand points out, following Jackendoff (1996) and Hay *et al.* (1999), that only a property of the participant undergoes a change, rather than the participant itself. She observes that, generally, in eventualities in which the physical extent of the participant is affected by the process, the telic structure (the one which includes the result phrase) is preferred.³⁵ If some (other) state of the participant is

³⁵ I use the term physical extent in the sense it is used in the linguistics literature, e.g. the discussed paper by Ramchand. It denotes the literal or metaphoric volume, length or other size that is seen as a property of a certain entity; this property can be measured (e.g. by Krifka 1998's extensive measure functions); and having zero as the value of this measure for some entity is equivalent to the "nothingness" of this entity.

undergoing change, including change in its location, the result value of this state needs to be overtly specified in order to have a telic reading. This has serious consequences for the three approaches presented above.

For Verkuyl (1972) and Krifka (1992, 1998), it means that the [+SQA] feature or quantization of the direct object corresponds to the telicity of the eventuality only if the physical extent of the object is directly affected.³⁶ In other cases, the directly corresponding property will be the [+/-SQA] feature or quantization of the degree of change of the affected property (similar to Krifka's and Jackendoff's metaphoric paths). The direct object is then only indirectly involved, through distributive readings. Whether the eventuality is telic or not actually depends, in both cases, on the presence of the result subevent in the description of the eventuality. The only difference is that in the former case (the physical extent of the object is affected), the affected property is not independently represented, but semantically incorporated into the meaning of the direct object itself.

One of the strong points of Ramchand's model relates to rigidly telic verbs such as *to kill*. An eventuality described with this verb requires a certain telic point and cannot be associated to any activity without a culmination. Killing is not killing without resulting in someone's death, and this component of a corresponding eventuality always needs to be represented. Ramchand suggests that this is due to the fact that verbs of this type incorporate the final state of the eventuality, i.e. the predicate of the result subevent. In section 4.7, I suggested something similar, except that I also pointed out the idiomatic nature of this incorporation for cases which resist any 'coercion'. This illustrates why a decompositional approach requires that certain functional features be represented in the lexicon. If the lexical entry of the verb *to kill* includes the predicate of the result state, then it also includes the functional feature that projects its phrase.

Another possible explanation for the contrast in rigidity between the verbs that incorporate the result predicate relates to the scalar nature of the incorporated predicates. In order to be atelic, a clearly scalar predicate such as in (94a) only requires a context which signals that the degree of straightness is changed and not the absolute presence or absence of this property. This is not at all possible for strongly non-scalar predicates such as being dead in (94b). This approach is argued for in Hay *et al.* (1999).

- (94) a. John straightened the rope in an hour/?for an hour.
 b. John killed Mary in an hour/*for an hour.

I do not extensively discuss approaches based on the scalarity of predicates. The model proposed in Chapter III derives the effects attributed to the opposition between scalar and non-scalar predicates by the opposition between a single temporal interval and a concatenation of two temporal intervals.

Finally, Ramchand touches on some of the questions raised at the end of section 5. In particular, she briefly sketches her position with respect to the relation between 'regular' quantification and what Krifka refers to as the mereological mapping

³⁶ Krifka in fact tackled this problem by postulating the two types of uniqueness, but without a direct relation to the fact that it is only one property and not the entire (predicate of) the participant that is affected in an eventuality.

between participants and the eventuality. Ramchand suggests that the latter type of effects, involving bare plurals and quantified nominal expressions, are probably simply a consequence of distributive readings of the eventuality over the particular participant. Thus, the facts in (95) are due to the distribution of eventualities over sandwiches. There are, respectively, an undetermined number, three, and some eventualities of John eating a sandwich in these three sentences (the collective readings in which three sandwiches and some sandwiches are taken as one singular collective unit are possible as well, but less relevant for the current discussion). This means that the effects of quantification must be accounted for in terms of a theory of quantification, and not by special tools such as mapping or range assignment.

- (95) a. John ate sandwiches for an hour/*in an hour.
 b. John ate three sandwiches in an hour/?for an hour.
 c. John ate some sandwiches in an hour/?for an hour.

Ramchand provides some hints concerning the division of labor and the relations between outer and inner aspect. In addition to perfective, prospective and progressive meanings, she also views iterativity as related to outer aspect. She moreover allows that a telic reading can be imposed to an eventuality on the level of outer aspect, for instance by a PP introducing the result of the eventuality by adjoining at the level of outer aspect. This adjunction targets the structure higher than the VP, i.e. higher than the structure reflecting the decomposition of the eventuality. This is quite surprising if telicity is associated with the presence of the result subevent. If, nevertheless, it can be imposed at a higher level, and even onto a structure which has no result subevent, then there are two options for how it happens. One is that the structure which is already built can be changed as a consequence of adjoining a certain PP to some higher projection (in generative syntax referred to as a *countercyclic derivation*). The other is that there is at least one more projection with the same effect as the result subevent phrase. Neither option is very attractive.

With respect to its position at the interface between syntax and semantics, Ramchand's model in many respects has the best of both worlds. It makes use of syntactic principles to explain phenomena related to syntax (e.g. case assignment), and at the same time it uses an intuitively plausible model of semantic decomposition to explain the semantic aspects. Ramchand reduces the effects previously seen as a mapping between the eventuality and its participants to two more standard phenomena: quantification and the composition of the VP. The cost she has to pay is having lexical entries associated with certain functional and selectional features that simultaneously belong to the domain of syntax and pragmatics.

6.3. Two reasons for dropping the process subevent

One observation that poses some problems for Ramchand's model is that eventualities in which the Undergoer and the Resultee are different do not seem to exist. Sentences like in (99) are, to my knowledge, cross-linguistically ungrammatical.

- (96) a. *John painted the car his hands red.
 (intended: John painted the car and as a result his hands became red.)
 b. *John kicked the ball the vase down.
 (intended: John kicked the ball and as a result the vase fell/was down.)

- c. *John wiped the table the cloth dirty.
(intended: John wiped the table and as a result the cloth was dirty.)

From the point of view of the model, this is quite unexpected, as the middle sub-event generates an independent argument in its specifier position. However, it is in agreement with intuition: the result is supposed to represent the ending value of the property that is undergoing a change. This should naturally be a property of one and the same participant, which means that the same participant will always appear in both positions, if both subevents are present and the participant is overtly specified. The structure that emerges has two adjacent projections that always have identical specifiers. It is therefore tempting to try and reduce this structure to only two subevents. However, such a structure would clearly clash with two important aspects of Ramchand's proposal. One is the principle that the process subevent is the nucleus of a non-stative eventuality and cannot be omitted.³⁷ The other is the way mapping and non-mapping Undergoers are handled: there would only be one subevent available for both. Before leaving this point to the broader discussion in Chapter III, I would like to clarify and briefly discuss Ramchand's position, culminating in a very general sketch of the model that I argue for.

In fact, Ramchand herself does not believe that Undergoers and Resultees are always the same, and she even gives several examples of eventualities in which they differ. Typical examples are given in (97) (borrowed from Ramchand 2002, her examples 104 and 155).

- (97) a. Karena ran her shoes ragged.
b. Michael ran Karena to the coconut tree.

Ramchand's analysis of (97a) is that Karena is the Initiator and the Undergoer, while her shoes are the Resultee. Semantically, therefore, Karena performs the action of running, by virtue of which she changes location, and the result of this is that her shoes are ragged. In (97b), Michael is the Initiator and the Undergoer, while Karena is the Resultee. Therefore, Michael performs the action of running and changes his location, the result of which is that Karena is at the location of the coconut tree.

I think, however, that both sentences are analyzed incorrectly. In both cases, the Resultee should also occur as the Undergoer. In (97a), Karena performs the action of running, but it is the shoes that undergo the change, and the final state of this change is being ragged. Although the verb *to run* normally appears in a structure where the Undergoer is identical to the Initiator, in this case, the situation is different. It is the kind of result that triggers the difference in interpretation, changing the subject of process from being identical to the Initiator to possibly being different. Therefore, in (97a), Karena can be running on a machine and still running her shoes ragged, although her location is not changing at all. In (97b), without a different Resultee, this is not possible. Karena cannot run to Mexico without changing her location.

³⁷ On the one hand, it might seem strange to eliminate something that has been claimed to always be present. On the other hand, an element that is always present actually plays no distinguishing role. Therefore it cannot be very relevant. The only distinction that the process subevent makes in Ramchand's model is the one between stative and non-stative eventualities. However, this distinction can as well be attributed to the complexity difference between the stative and non-stative eventualities. This difference remains even if (only!) the process subevent is dispensed with.

- (98) a. Karena ran to Mexico.
 b. Karena ran her parents to Mexico.

Finally, in the sentence in (98b), Karena can run her parents to Mexico without necessarily ending up in Mexico herself, or even without changing her location. For instance it is possible to imagine the scenario in which Karena runs in a competition and with every step she makes, her parents are awarded one more mile in a trip they can choose at a travel agency. After a number of steps, Karena will have won enough kilometers to get her parents to Mexico. Karena, of course, will not be in Mexico at that point.

Finally, in both cases in (98), Karena may be walking or running on the machine, in which case she would not even have to change her location to have her parents or herself ending up in Mexico (in the case in which she gets to Mexico, it must be by other means than running). It is therefore only the pragmatic tendency to interpret the verb *to run* as changing the location of the Initiator that makes the reading in which this is the case more prominent.

If the analysis that I suggested above is correct, a proper treatment of eventualities in Ramchand's model leads to the generalization that the Undergoer is always identical with the Resultee. This either is a regularity, which then needs to be explained, or it is an indication that one of the two subevents in which these two participants are derived is redundant.

Another problem related to the model of decomposition proposed by Ramchand concerns the Initiator. Ramchand's model, which clearly distinguishes between the initiating and the process subevent, represents the participation of the Initiator as a state that initiates the eventuality (she assumes that activities can be seen as states when observed without the process component). In a similar way, the result subevent is the state at which the eventuality ends. The latter presumes a clear ordering relation, which, in the end, is assigned temporal nature. This is perhaps not explicit at the level of the eventuality, but at the level of external aspect or tense, the result subevent certainly has to map onto a temporal interval that is later than the one of the process. In fact, the reverse must hold for the initiating part as well. It is not possible that the initiating part begins after whatever it initiates. In (99), the bomb can only be in parts at the end of the eventuality, i.e. only at the end point of the process of diffusing. Analogously, for the initiating subevent, this means that John only pursued an action of diffusing at the starting point of the process of diffusing and did not continue to pursue it during the process. This does not sound like a correct analysis. In fact, John should pursue the action that 'initiates' diffusing during the entire process of diffusing.

- (99) John diffused the bomb into parts.

This indicates that there is an asymmetry in Ramchand's ontology between the initiating and the result subevent. One of them temporally maps as adjacent to the end of the process, and the other maps as starting before, but also possibly overlapping with the process subevent, up until its end. Again, just as with the identity of Undergoers and Resultees, discarding the process subevent would eliminate the problem. If the process is just a part of the initiating subevent, the temporal ordering is simpler and uncontroversial.

6.4. Traveling light: without the process subevent

Let us now explore what Ramchand's model would look like without the process subevent. Following the first step of cutting off the middle third of the structure, it looks quite similar to the structure I introduced in Chapter I, which is repeated here as (100). It represents two states, corresponding to Ramchand's initiating and result subevent, one of which is projected on top of the other to build the complex structure of a non-stative eventuality.

(100) The two-subevent structure from Chapter I.

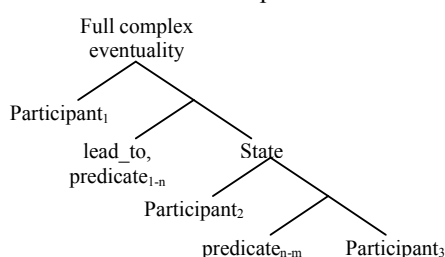

The subject of the lower subevent corresponds to Ramchand's Undergoer and Resultee, of which I claimed earlier that they are identical. The predicate of this subevent specifies the result state of the participant. The subject of the higher subevent is the Initiator. The Initiator is engaged in some activity or state, which leads to the result state.

In non-syntactic terms, this can be represented as in (101), where a comparison is provided with the ontology argued for by Ramchand.

(101) a. Schematic representation of Ramchand's general ontology of eventualities

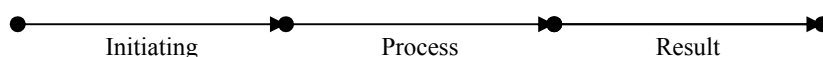

b. Schematic representation of the reduced ontology of eventualities

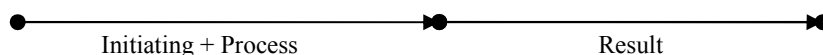

At first sight, it seems as if this deprives us of the option that I presented as an advantage of Ramchand's model. Her structure very elegantly solves the problem of non-mapping Undergoers as in 'pushing the cart' by relating them to the process subevent. Since this option is no longer available, there is only one position for the direct object, in the result subevent. This means that every time a direct object is specified, the eventuality has no choice but to be telic. However, this is not correct. As Ramchand argued, the difference between states and activities is grammatically very small, and appears to have no strong effects on argument structure. We can therefore take atelic transitive VPs to be states or processes represented in a transitive structure, which is not unusual for states (witness verbs such as *to trust*, *to know*, *to love*). This means that the work performed by the position of the subject of

in fact features of outer aspect produce the relevant effects. (She suggests that apart from deriving the perfective, prospective and progressive readings, outer aspect also relates to the meaning of iteration.) The other is that these effects can appear as a consequence of distributive readings for the eventuality, in which it distributes over its arguments and therefore acquires the same quantificational properties.

I pointed out two problems in Ramchand's account, related to the process subevent. One is that its subject (the Undergoer) is always identical with the subject of the result subevent (the Resultee), which is unexpected given the definition of the structural argument positions. The other is that in the temporal interpretation of the eventuality, the interval of the process subevent normally is part of the interval of the initiating subevent. Hence, I proposed a simplified version of her model, containing only the initiating and result subevent, with the former also containing the meaning that Ramchand assigns to the process subevent. Thus, the advantages of Ramchand's model are maintained, but the structure is simpler and it avoids certain problems. Under the proposed simplified model, telicity corresponds to the complexity of eventualities: all atelic eventualities are simple, and all telic eventualities are complex. The complexity involved is minimal: there are only two subevents in every telic eventuality. Instead of three stipulated heads deriving the tripartite decomposition (*initiate/cause*, *change* and *result*), the proposed model only has one, the predicate *lead_to*, which determines the relation between the two combined simple eventualities, and contributes dynamicity.

7. Conclusion

In this chapter I discussed problems of inner aspect. In section 2, the notion of inner aspect is introduced, followed by the presentation of one of the earliest theories of aspect: Vendler (1957). I showed how the decompositional model of eventualities at the syntax-semantics interface developed in Chapter I can also capture the aspectual types recognized by Vendler.

Introducing the notion of inner aspect, we only dealt with a restricted set of nominal expressions in the argument positions. Once these expressions are varied, in particular with respect to their quantity, new observations with respect to telicity arise, which are not captured by the proposed structure. A first attempt to formally model generalizations concerning the relation between the inner aspect of a VP and the quantificational properties of its arguments can be found in Verkuyl (1972). In section 3, I outlined Verkuyl's work, stressing the compositional nature of his account of eventualities. This section exposed a number of major regularities in the relationship between properties of arguments and Verkuyl's general strategy for accounting for them. In his model, lexical verbs are specified as being dynamic or not ([+/- ADD TO]) and nominal expressions appearing as arguments for whether they have a specified quantity ([+/-SQA]). In order to be telic, an eventuality must be composed only of elements with positive values for these two features. Any negative value immediately leads to an atelic eventuality.

I pointed out some problems for Verkuyl's model. The central problem is related to the representation of eventualities involving dynamic ([+ADD TO]) verbs which derive the inner aspect as atelic irrespective of the ([+/-SQA]) feature of their arguments in those cases where no Goal or Path participant is provided, as in (103).

- (103) a. John pushed the cart for ten hours/?in ten hours.
 b. John pushed the cart to the shop in ten hour/*for ten hours.
 c. John pushed the cart to shops for ten hours/*in ten hours.
 d. John pushed carts to the shop for ten hours/*in ten hours.

Verkuyl proposes to account for these verbs by presenting them as complex structures, involving a verb and an additional argument. I showed that this structure: a) does not capture all the aspects of the meaning of these eventualities and b) if accepted anyway, it will apply to all eventualities and not only to the targeted class.

One of the central questions regarding the relations between the eventuality and its arguments is how these two different types of semantic elements can be brought to the same level, in order to be formally related. Krifka (1992, 1998) proposes a mereological approach, which heavily stresses the properties of predicates: cumulativeness and quantizedness. Krifka calls these two properties reference types, because they relate to how predicates establish reference. Cumulative predicates are those that are closed under sum. Quantized predicates are such that if they hold for an entity then they do not hold for any proper part of this entity. Other mereological approaches add a third relevant reference type: divisiveness. A predicate is divisive if when it holds for an entity it also holds for all the parts of this entity. Krifka sees the dependencies between arguments and eventualities as part of the meaning of certain thematic roles. These thematic roles are specified as mapping between the argument that they introduce and the event argument. Mapping is established between elements of different categories (eventualities and nominal expressions) through the one level they share: (the reference types of) their predicates.

In the same section, I presented an approach in which divisive and cumulative predicates represent identical sets in natural language. I proposed that the apparently divisive non-cumulative or cumulative non-divisive predicates, such as for instance *more than ten apples*, receive their epithets due to an incorrect application of tests, having to do with the scope of the quantifier *more than ten*.

Krifka faces the same problem as Verkuyl. As illustrated in (103), the affected object role of some verbs appears not to map its object onto the eventuality. Krifka introduces the notion of a movement relation to account for the class of verbs with which he associates this behavior. These verbs involve another mapping role: Paths (associated to movement). Krifka also defines the roles of Goal and Source, basing his definitions on the semantic type of paths. In Krifka's definition, the mere presence of the Source and the Goal is sufficient to derive a telic eventuality. I have criticized this point of view, pointing that the data in fact show that Goals and Sources are also mapped onto the eventuality (possibly indirectly, through the Path). Furthermore, the presence of any of these three roles triggers mapping of the affected object of the eventuality, which does not occur if they are absent.

I have also shown that there is a gradation between the verbs that always map their Undergoers and those that only map them in the presence of a Path. I have shown that almost all telic eventualities, including those that by default involve mapping, even without a Path, at least have the option of taking a participant with a Path, Goal or Source role. The exceptions seem to be verbs that incorporate their Goals (therefore not really exceptions), some of which are also to a certain extent idiomatized. I suggested that in fact all verbs share the same property in requiring a

Path in order to license any mapping. The Path can be represented directly or indirectly (through the simultaneous presence of a Goal and a Source). The latter option includes incorporated Goals as a special possibility. Seen in this way, a Path corresponds to the process in a change and a Source and a Goal to its starting and its ending value (the result) respectively.

The same mereological properties are used in the radically syntactic approach of Borer (2005b), presented in section 5. Borer derives inner aspect and argument structure from the syntactic structure that represents an eventuality. She introduces a particular syntactic projection which she calls the aspectual phrase. In this projection, by means of specifier-head agreement, a certain feature is assigned from an NP to the predicate of the eventuality, or the other way around, from the predicate of the eventuality to its argument. This phrase optionally projects, but when projected it must be assigned a value. The denotation of the NP that appears in the specifier of this phrase and which takes part in assigning the relevant value is interpreted as the subject of quantity. Since quantity relates to the change denoted by the eventuality, this participant is also interpreted as the subject of change. In Borer's model, the relevant feature, which is assigned to the head of the aspectual phrase, corresponds to the mereological notion of non-homogeneity. Non-homogeneous predicates are those which are not both cumulative and divisive. Borer therefore claims that it is sufficient for an argument to be represented by a non-homogeneous predicate to derive a telic eventuality. Borer even gives examples such as (104), claiming that the eventualities in them are not quantized. For instance, the one in (104a) is divisive and non-cumulative: all parts of walking to the shop which end at the shop, wherever they started, have the same predicate of walking to the shop.

- (104) a. John walked to the shop in ten minutes/*for ten minutes.
 b. John filled the room with smoke in ten minutes/?for ten minutes.
 c. The boat sank (to the bottom) in ten minutes/?for ten minutes

In Borer's model, mapping between the eventuality and its Undergoer is not seen as a property of a particular class of verbs or even eventualities. The lack of mapping, or rather of the effects attributed to it, is simply viewed as a consequence of not projecting the aspectual phrase in the syntactic structure of the eventuality. The fact that certain verbs do not appear in certain structures is in her view a consequence of a number of pragmatic facts, especially our world knowledge. Therefore, the facts in (103), which were problematic for Verkuyl and Krifka, are natural in Borer's theory. However, this gain costs Borer the ability to explain certain regularities related to this type of eventualities. For instance, she can no longer account for the fact that eventualities with only the Goal or only the direct object being homogeneous are always only atelic. There is no obvious reason why these eventualities will never choose the option to project an aspectual phrase. This is surprising since they still have one argument that can assign the required value to them. As shown in the section on Krifka (1992, 1998), these facts follow naturally from the semantic decomposition of eventualities.

The fourth account I presented is the one by Ramchand (2002). She proposes a syntactic decompositional model where the syntactic structure determines a general ontology in which eventualities are composed. Her model is based on three subevents which represent three semantic components of a non-stative eventuality.

These components are the initiating subevent, the process subevent and the result subevent. Each of these subevents also generates one structural argument. Different argument structures are derived by omitting the initiating and/or the result subevent. The process subevent cannot be omitted.

Ramchand's model offers an intuitively plausible and straightforward picture of the syntax-semantics interface. It avoids most of the problems faced by other approaches, including the problem of non-mapping Undergoers (cf. (103)). Yet, Ramchand's model faces the same complications as the model sketched in Chapter I: different quantity properties on the participants of the result subevent seem to give rise to different behavior patterns in telicity tests. An eventuality that should be telic because it contains a result subevent appears as atelic when its subject of result is a bare plural or mass nominal expression. Ramchand argues that these effects are an instance of distributive readings, and are therefore produced higher in the structure than the decompositional pattern that she proposes. She in fact allows for the (a)telicity of the VP to be changed in the higher structure not only from telic to atelic, but also the other way around. This can be done by adjoining a constituent which entails the final value of the change. This step raises some problems for her account and requires a more elaborate model of outer aspect.

I pointed out two problems in Ramchand's model: the fact that the process subevent subject (the Undergoer) and the result subevent subject (the Resultee) are always identical, and the tendency of the process subevent to be temporally interpreted as a part of the initiating subevent. Both these problems can be solved by eliminating the process subevent, reintroducing in fact the structure from Chapter I. This leads to a structure in which all atelic eventualities are represented as one simple phrase, and all telic eventualities consist of two phrases such that one appears as the complement of the other. These two phrases are related by the head of the higher one, which marks the higher phrase as denoting a process and the lower one its result. Abstracting away from this head, every phrase that appears either as an atelic VP or as part of a telic VP is a syntactically simple predicate. It may take only one argument, or relate two different arguments. This provides a simple system which operates only with predicates, and by assigning them a structure – it also takes care of the syntactic aspectual and argument-related properties. This is where an additional aspect of the model becomes apparent.

Table (105) provides a comparison of the four approaches presented in this chapter with respect to five relevant parameters.

(105) Major properties of the four presented approaches

	decomposition	event arguments	most prominent modules	quantity/ mereology	properties of lexical verbs
Verkuyl	Yes	No	syntax and semantics	quantity (+dynamicity)	[+/-ADD TO], XP-compl.
Krifka	Yes	Yes	semantics	mereological notions	thematic roles
Borer	No	Yes	syntax	both	none
Ramchand	Yes	(not explicit)	syntax and semantics	none	functional features

Only one approach explicitly denies the relevance of decomposition: Borer (2005b). For the other approaches, this aspect of the analysis is not even questioned, and in Ramchand (2002) it plays a central role: it is assigned an ontology and used to derive most of the observed phenomena.

Only Verkuyl's (1972, 1993) model is explicit about having no event arguments: for him, the VP compositionally builds the meaning that relates to the eventuality. Ramchand also makes no explicit use of event arguments, but she does not argue against them. Krifka (1992, 1998) and Borer (2005b) give event arguments an important role in of their theories.

With respect to the domain in which they see the locus of the phenomena related to eventualities, Krifka and Borer take two extreme positions. Krifka attempts to provide a purely semantic account, while Borer is explicit about using only syntax. Verkuyl and Ramchand base their accounts on the interface between the two modules. Of the two, Verkuyl is the one who puts more weight on the semantic side, while Ramchand's model is slightly more syntactic.

Once again, only one approach stands out with respect to the role of quantity or mereology. Only Ramchand considers this domain to be completely irrelevant for the syntax and semantics of an eventuality. In her view, the relevant effects are a matter of distributivity and other phenomena that are independently investigated for other categories as well. Verkuyl talks about specified quantities, Krifka descriptively uses mereological notions and Borer derives mereological properties from having a specified quantifying predicate within the aggregate predicate of the event argument.

Finally, all four approaches differ with respect to their view of the role of the lexical verb in the structure of the eventuality. Verkuyl assumes that one of the two properties that are central for his approach, the [+/-ADD TO] feature, is specified on the lexical verb, while at the same time, the verb is specified for whether it requires an additional argument in the composition of inner aspect. In Krifka's approach,

only one relevant property is read off the verb: the type of the thematic role, which is specified for whether it involves mapping between the eventuality and the participant, whether the argument and/or the eventuality exhibit uniqueness in this mapping, etc. Borer takes lexical units to be entirely unspecified for any features relevant for syntax. Ramchand takes a less extreme approach along the same lines. She allows for the lexical verb to carry some functional features, which then determine which syntactic structures this verb can project.

In Chapter III I show that the step with which section 6 ends, reducing Ramchand's model by eliminating the process subevent in the way described, yields a model that has all the advantages of Ramchand's structure, does not pose any additional problems, and significantly simplifies the syntactic structure and its interpretational properties. In Chapter III, I argue that a decompositional core of the structure of the VP is the correct way to account for inner aspect and argument structure. In addition, I try to provide a more explicit account of the effects of properties of quantity on inner aspect, which results in a slightly more complex structure. This account incorporates the results of the theories of Verkuyl (1972, 1993), Krifka (1992, 1998) and Borer (2005b).

Chapter III: Eventualities at the syntax-semantics interface

1. Introduction

In Chapter II, I discussed several different views on how eventualities should be represented. These views can be positioned along two axes. One is concerned with the presence and degree of interaction of syntactic and semantic aspects in such representations. The other dimension consists in answering the question of whether the proper treatment of eventualities should be defined in terms of (de)compositional aspects or of aspects relating to mereological relations.

In this chapter, I present a novel approach to eventualities which, to a large extent, reconciles the two oppositions mentioned above. In this model, syntax and semantics have a very strict correspondence and very few of the model's properties are explained in terms of only one of the two modules. Simultaneously, the relatively simple structure that I propose for eventualities accounts for both decompositional and mereological observations.

In section 2, I start from the model we arrived at in section 6 of Chapter II, and I observe some of its contradictions. In solving these contradictions, I develop a more refined model, which is based on a structure that I call the telic template. In the remainder of the section, I sketch the main properties of this model in the light of decompositional semantics. In section 3, the model proposed is discussed with respect to the achievements of the mereological approaches. I introduce a division between telicity and inner aspect along the lines suggested in the last paragraph of section 4 in Chapter II. In this division, inner aspect corresponds to a quantification over the eventuality, and telicity corresponds to the level of mass division. I propose a structure parallel to that of nominal expressions as the structural representation for these two aspects of VP semantics. Section 4 discusses some possible points of criticism for the model, and provides additional arguments. In section 5, I conclude.

Before continuing to sketch the model, I would like to stress one aspect of the context in which it is developed. The model is meant to satisfy both theoretical linguistic requirements and the major requirement of Natural Language Generation: to be suitable from the point of view of language production. This means that the model that is developed will often be seen in a context in which a semantic representation of an eventuality is taken as the input and its syntactic realization as the output of the model. This is also reflected in my views on quantification, scope, and the positions in which certain elements are (base-)generated. I consider, for instance, that a single element is often independently generated in more than one position, or more precisely in every position in which it predicates/scopes. This gives a very rich and explicit semantic representation with multiple copies of the same semantic material in different positions in the hierarchical structure. In general, I assume that the interface between syntax and phonology reduces the multiple copies as much as their structural relations allow. When a constituent appears in more than one position, it usually has a full lexicalization in only one of these positions and, depending on some appropriate locality relations with it, all its other instances in the sentence have a reduced realization. This reduction can result in a (possibly resumptive) pronoun, an anaphor or a clitic, or in full deletion. Mechanisms of reduction are not covered in this dissertation.

2. Refining the model

2.1. Introduction: the model presented in the preceding chapters

In section 3.3 of Chapter I, we arrived at the model of eventualities presented in (106). In this model, two states, each represented as a simple phrase, establish a relation in which one of them (State₂) is the complement of the other (State₁). In addition to this, the head of State₁ involves the predicate *lead_to*. The derived interpretation is that State₁ continues and reaches a point at which State₂ is established. In this way, State₁ acquires the property of process, entailed by the fact that it leads to a change, i.e. to a new value for a certain property. State₂ acquires the property of result, because it specifies this new value. The combination of the initiating and result interpretational components is taken to derive telicity and this entire template therefore represents the structure of every telic eventuality.

(106) Decompositional model of full eventuality at the syntax-semantics interface.

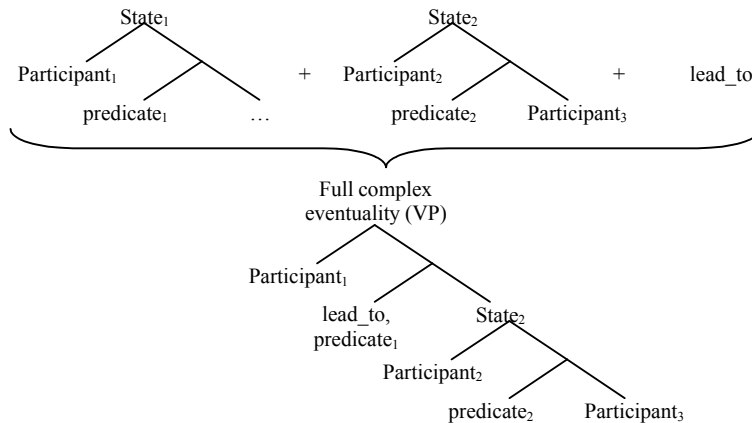

Let me illustrate this with a concrete example. The VP of the sentence in (107) is presented as a structure built from two phrases, each of them representing a state.

(107) Structure of the VP in 'John pushed the cart to the shop'

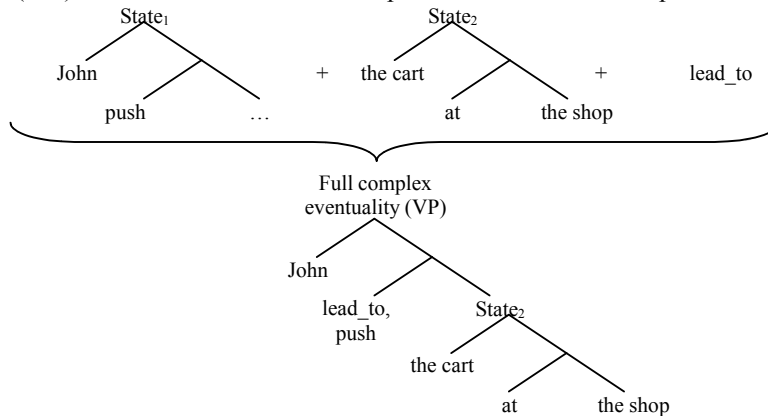

One state (State₁) involves the conceptual contents of the verb *push*, applied as a predicate over two arguments. One of the arguments of State₁ is *John* and the other is State₂.³⁸ The head of State₂, i.e. its predicate, carries the conceptual contents of the preposition *at*. It marks the very simple spatial relation of having locations which are near each other. This predicate takes two arguments: *the cart* and *the shop*. The full structure is interpreted as follows. John is in the state of pushing, which has the property of being a process and results in the cart being at the shop.

The structure presented here is, as mentioned in Chapters I and II, a hybrid of several recent models of event structure. In syntax, it combines elements of the approaches like Larson (1988), Hale and Keyser (1993) or Svenonius (1996), and in semantics it most directly incorporates elements of the theories of Parsons (1989), Pustejovsky (1991) and Ramchand (2002). In this section I will briefly discuss several special forms that this structure may take, to show how it can handle some of the central phenomena of the aspectual and argument structure. In the remainder of the chapter, I propose fundamental modifications to this model, which bring a number of theoretical and implementational advantages.

The structure in (107) can appear in different underspecified forms. One option is that the specifier of the higher phrase (the subject of State₁) is not specified. This derives the unaccusative structure presented in (108). The participant that contributes the *lead_to* component is not present in the interpretation of the eventuality. Apart from that, it is equivalent to the full template.

(108) Telic unaccusatives (the specifier of State₁ unspecified)

‘The cart rolled to the shop’,³⁹

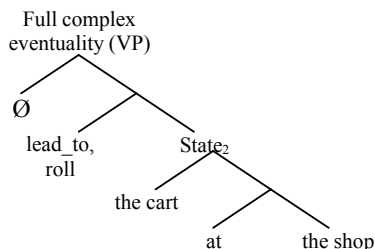

It appears to be impossible, except in pro-drop languages or in cases of ellipsis, to leave any other argument of the telic structure unspecified, as the impossibility of properly unspecified telic readings in (109) confirms. This overtness requirement is particularly strong for the Undergoer (the specifier of the lower phrase), since in these cases even a strongly contextually provided candidate does not lead to a well-

³⁸ I use the term *state* in a more general sense to denote both states and processes, which share the property of being homogeneous, atelic and represented as simple eventualities, without a more complex structure. These aspects of the term are presented in Chapters I and II. However, I still use the term *process* to denote a dynamic kind of state.

³⁹ The fact that the predicate of the result state in this example is represented as *at* and the sentence realizes it as *to* indicates that I treat the preposition *to* as the lexical realization of the meaning associated to the preposition *at* when it appears in the result subevent. In fact, I would even go as far as taking the morpheme *to* as the marker that appears on a locative preposition and marks agreement with the head that assigns it a result interpretation (i.e. with the head of the first higher phrase). For a more thorough discussion of the prepositional meanings, see Arsenijević (2005a).

formed structure. For the Goal (the complement of the lower phrase), it is possible to contextually force certain acceptable readings (for instance if the bounded path of the pushing eventuality in (109b) is strongly contextually suggested).

(109) Eventualities lacking specification of the Undergoer or the Goal

a. *John pushed to the shop in 3 hours.

b. *John pushed the cart (to) in 3 hours.

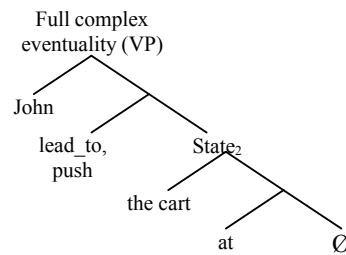
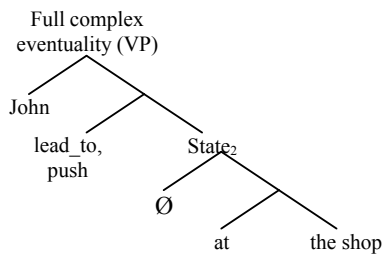

In this section and in section 3, I present a model in which the Undergoer, unlike the Goal and other roles, apart from its direct semantic contribution, also has a special status with respect to the structural representation of the eventuality. The asymmetry observed above therefore results from the special place of the Undergoer in the structure of a telic eventuality.

The other interesting underspecified form of the full template of eventuality is the one in which one of the two states is empty and therefore absent from the structure. This structure represents atelic eventualities, both those involving a process, as in (110a), and those involving proper states, as in (110b). An interesting question at this point is whether these two types of eventualities have a different representation in grammar or not. So far, I treated them as equal, calling them both states, but I address this question more explicitly in subsection 2.6.

(110) a. John pushed the cart.

b. John knows Mary.

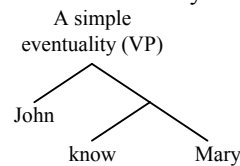
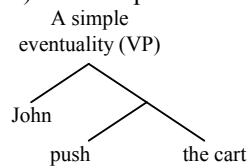

Finally, it is possible to combine the two ways in which the template can be underspecified, in which case a number of underspecified argument structures of atelic eventualities are derived. If the eventuality lacks an overtly specified complement, the derived structure is the same as for unergatives, as in (111a). If the missing argument is the specifier of the phrase, the derived structure is an atelic unaccusative, as in (111b). And if it lacks an overt specification of both its arguments, the structure derives an 'impersonal' atelic eventuality, as in (111c) (this requires that the expletive *it* is generated in some higher position and does not represent a participant in the eventuality).

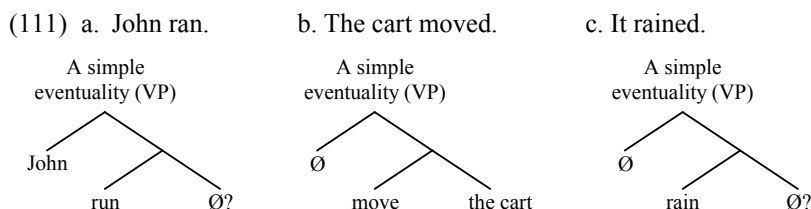

These last three structures seem to point to the following property. There seems to be a difference between the ways in which the specifier and the complement are unspecified. It has been argued, since Hale and Keyser (1993), that unergatives usually involve the incorporation of the object into the verb. If this were the case, then the lack of an overt complement would normally still involve a light participant of the relevant kind, which underwent incorporation, while the lack of an overt specifier in the representation of a state would completely exclude the interpretation of this argument from the structure. In other words, the empty categories involved in the two classes of verbs differ. The empty category in the complement position stands where an incorporated argument was generated before incorporation. This argument is still easily recoverable from the verb: it is just not overtly specified as an argument. The empty category in the specifier position stands for a participant that is really unspecified. In the semantic interpretation, it is ambiguous between any possible referent in the discourse. Some disambiguation is usually provided by pragmatics, from the discourse and real world knowledge, but the degree of recoverability is zero, since nothing has even been generated in this position.

Just for illustration, let us look at the examples in (112).

- (112) a. John ran.
 a'. John did/made a run.
 b. John yawned.
 b'. John did/made a yawn.
 c. John slept.
 c'. John was asleep.
 d. Kiši. S-C
 rains
 'It rains.'
 d'. Pada kiša.
 falls rain
 'It rains.'

The ergative verbs in (112a, b, c) can all have a more or less felicitous paraphrase involving a light verb and an object (112a', b', c'). The same holds for the impersonal VP in (112d), for which I give an example from Serbo-Croatian (S-C), where the fact that the expletive is not required makes the point more obvious. Light verbs are indeed what we expect as a result of depriving the head of the phrase of all its incorporated contents.

However, in the unaccusative and stative VPs in the given examples, it is not possible to reconstruct any Initiator. If anything caused John to be asleep in (112c), there is not only no hint in the VP as to who or what that is, but even that there was a

causal relation involved. Moreover, if anything caused the rain to fall in (112d), there is no specification whatsoever in the VP of what that is, and no hint that the eventuality involves an initiating component.

If all lexical semantic material in the meaning of the verb is taken to be incorporated from its complement, then the only structure that could be treated as genuinely intransitive would require a light verb without any overt or contextually given participant appearing in the complement. However, such sentences would be ungrammatical, as shown in (113).

- (113) a. *John was.
 b. *John does.
 c. *John has.

This is in fact quite intuitive. For any predicate, there must be at least one property of its most direct, or deepest, argument, i.e. of its complement, that the predicate modifies or gives a value to. Being the most direct argument of the predicate, i.e. being generated in the complement position, also means being first in the hierarchy that determines priority of specification, i.e. obligatoriness of an argument. In other words, only if no argument of the predicate is specified will it be possible to have an unspecified complement of a state. This would give us a predicate corresponding to a light verb, without a single argument – a meaning that is fully informationally vacuous. This implies that unergatives are transitives in disguise and only unaccusatives really have a structure with an unspecified argument.

One final interesting property of the presented template is that it can have the same referent in more than one position. For instance, in the structure in (111a), there are two possibilities. One follows from the discussion of ergative structures above, and it consists in having the semantic contents of the verb *run* generated in the complement position and then incorporated ('John made a run'). The other possible interpretation describes an eventuality initiated by John, in which he himself changes location. In other words, in at least one possible meaning, the sentence is interpreted as John acting in a running manner and changing location in this process. This structure is represented as in (114a), and as (114b) shows, it has a corresponding VP that takes a telic template.

- (114) a. John ran.

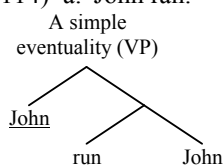

- b. John ran to the toilet.

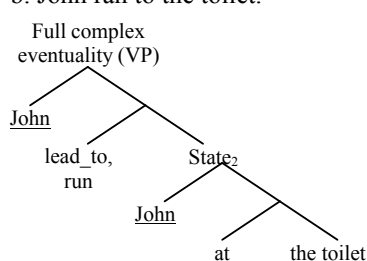

Normally, only one of the two identical instances of an argument (here *John*) receives a full overt realization, while the other instance is either left without any lexicalization, or it surfaces as an anaphor or a reflexive. The degree of reduction of the latter instance (anaphor, reflexive, clitic, deletion) depends on different aspects

of structural locality between the different instances of the same element, and possibly also on some phonological conditions, which I do not discuss.

In this chapter, I simply use two independent copies of such elements, assuming that they represent the semantic material in the relevant position. This approach requires a syntax in which lexicalization is done relatively late, perhaps at the PF interface (e.g. Distributed Morphology, as in Halle & Marantz 1993). The desirable syntax would, however, have no movement, but only independent base generation of the semantic material. When two structural sequences are filled with the identical semantic material and satisfy certain syntactic locality conditions, one of them can be elided, or lexicalized in some reduced way (for instance by resumptive pronouns). Since the dissertation is concerned only with the interface between syntax and semantics, I do not go into a deeper discussion of these problems.

With respect to aspect, the presented template, with its underspecified forms, corresponds directly to the distinction between telic and atelic eventualities. Atelic eventualities are simple and represented by one phrase alone. Telicity is derived in a structure involving two phrases, and realizing two predicates (two subevents). The intuition behind this is the traditional one, namely that telic eventualities have more material than atelic ones. They minimally require two eventualities: one that contributes the process, which in the present model coincides with the initiation, and one that specifies the telos (result, culmination). This minimal structure is reflected in the present model. At the level of aspect, this structure also leads to several interesting questions. Among them are the following.

What is the nature of a process and how is it related to the notion of result (particularly important for the present model, in which they both originate from the predicate *lead_to*)?

Can the result subevent be a process, or is it always a state and can the initiating subevent be a state or does it have to be a process?

How is the notion of process realized in atelic eventualities such as (110a) and (111), for they do not include the predicate *lead_to*? (There is no sense in which the predicate of these VPs would lead to their object.)

How can the relation between the two subevents that build the telic structure be formally defined and represented?

These questions underlie the entire chapter, and each section provides part of the answers. In treating more concrete questions, this chapter leads to a rounded and complete picture of what the template of a telic eventuality looks like, what its interpretational properties are, what restrictions it obeys and why.

2.2. Concatenation plus [ADD TO]

Before going on, let me give some necessary background for the way I will use the graphical tree representations and for the place of the structures they represent in the modular organization of grammar. I consider the structures represented by trees in this chapter, like for instance (115), to be semantic in nature. As such, they are present mainly in two different modules: in the lexicon and in semantics (LF), but they also occur at the interface between LF and syntax. In the lexicon, structures like (115b) represent the meaning of the lexical entry, and often have a large number of empty positions, which can be filled in syntax by structures involving other lexical material. At LF, these structures represent concepts, decomposed into primitive two-

place predicates which are structurally organized so that arguments of one predicate are always predications built from another predicate. The structure in (115a) represents the concept corresponding to the eventuality in which John runs to the toilet, ignoring other components of the sentential meaning such as tense, assertion etc. The representation is simplified in two ways. In the nodes filled with the name *John*, this name represents concepts with a complex structure deriving the meaning of the nominal expression *John* for the relevant context. The primitive predicates used, like *lead_to*, *at*, and especially *run*, are not really primitive, and should in fact be decomposed to a large number of primitive ones, for instance *place*, *legs*, *speed* etc.

(115) a. The VP in ‘John ran to the toilet’ b. Lexical entry /run/

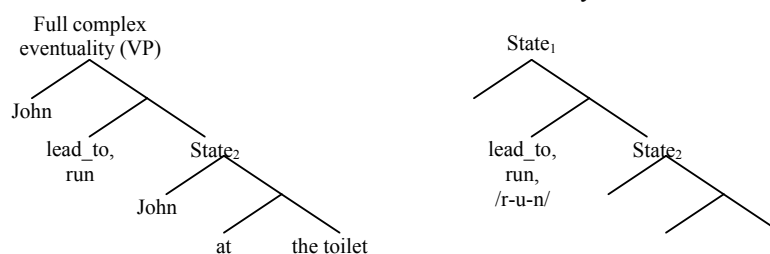

Taking other predications as arguments is a recursive property. It presents a danger for the model because it only derives infinite structures. This is avoided by allowing predicates to have unspecified (empty) arguments and by certain special properties attributed to deictic predicates.

By deictic predicates, I primarily mean those that directly link the referential properties of a certain concept with the context; in the nominal domain this is the predicate of definiteness, and in the verbal domain it is the predicate that orders the event time with respect to the reference time. Definiteness is interpreted as a property of a certain concept of having a discourse-old referent unique for the relevant world. The ordering relation with respect to the reference time entails that a certain eventuality is part of the world in which the relevant reference time belongs. Both, therefore, involve deixis to worlds.

The special property attributed to deictic primitive predicates is that the projections that they head are less transparent for different relations that can be established between predicates that c-command the projection of the deictic predicate and those c-commanded by this projection. One explanation for this could be that deictic predicates require a spell out to pragmatics, in order to interpret the deixis, and the structure that gets spelled out becomes inactive and inaccessible for the higher predicates. This notion quite closely corresponds to the notion of phase in some approaches to syntax (Chomsky 2001).

I assume that the syntactic structure is lexicalized in sequences, by matching the structures associated with lexical entries with parts of the sequence that is being lexicalized. A sequence in lexicalization is defined in the following way: all the nodes of a sequence have to be filled either with other lexicalized sequences or with primitive predicates, or they can be empty. The highest projection of each sequence is headed by a deictic predicate. Taking the structures that I talk about to be

semantic requires late lexicalization, which in fact only has to take place later than the LF-syntax interface.

This dissertation concentrates on the structures that are present at the very interface between LF and syntax, trying to explain the surface forms of VPs by a small number of syntactic and PF processes like concord, agreement or ellipsis.

Several questions posed in the preceding subsection target the nature of the predicate *lead_to*, which is taken as the nucleus of the complex (= telic) eventuality template. This predicate has two different effects. First, it introduces the notion of process in the structurally higher subevent of the telic template. Secondly, it specifies the relation between the two subevents in the template: one of them initiates the other, which is thus interpreted as the result. In addition to these two components, this predicate also shares the head in which it appears with the lexical predicate of the initiating subevent.

In order to properly define the notion of process that I am dealing with, a good starting point would be to look at the difference between atelic eventualities that differ only in this respect. Such are the two eventualities in (110), repeated as (116).

(116) a. John pushed the cart.

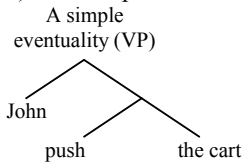

b. John knows Mary.

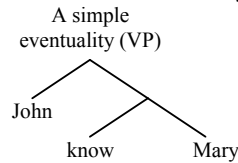

Both eventualities are atelic and both are represented by transitive VPs, but the one in (116a) involves a process, while the one in (116b), which is stative, does not. Verkuyl's (1993) description of this difference is that during the whole interval in which a state holds, the domain that it relates to stays unchanged. The meaning of the sentence in (116b) does not entail any change in the domain of the mental representation, or of the real world, to which it refers. This does not hold for the interval of an eventuality involving a process. At least one property of one of its participants changes in the course of this eventuality. In (116a), this is true of the location of the cart. That it is the location that is affected, and not some other property, is specified by the lexical semantics of the verb, i.e. by the other predicates that specify the relevant state and by the predicates of the participants involved. However, this change seems to be constant, homogeneous, and it does not single out any parts of the interval as having different dynamics or properties. A process can therefore be viewed as 'a state of process'.

Verkuyl represents this homogeneous change as a constant adding to the value of a certain property in the domain of the eventuality. Moving 'adds to' the location, heating to the temperature, learning to the knowledge, etc. Verkuyl, as discussed in Chapter II section 2, introduces the feature [ADD TO] to represent this property. When present, this property is marked with a plus-sign after the opening bracket ([+ADD TO]), and when absent with a minus-sign ([-ADD TO]). This property can be described as value-accumulativity, since it accumulates the value of the properties that it relates to over time. In what might be the most neutral definition, it is a monotonic function which maps from the temporal interval of a state onto the

value of a certain property from the domain of this state (a discussion of this view is given in 2.6). I use Verkuyl's name for this predicate, but for the sake of uniformity with my own notation, I write it without brackets, as *add_to*⁴⁰ (italics are not a part of the notation). So far, I include the predicate in the representation only when it is present, without making use of plus- and minus-signs. If this predicate is not part of the interpretation of an eventuality, it is simply omitted.

In Chapter II sections 2 and 4, I discussed the problem of the lexical nature of the feature *add_to* in Verkuyl's theory. Verkuyl takes this feature to be contributed by the lexical meaning of the verb, but since it is active in the syntactic structure of a sentence, this same feature should be seen as functional and not lexical. I assume, however, that all functional elements bear conceptual meanings and that the ones discussed here are therefore contained in the representations of the lexical meaning of lexical verbs. This can even go as far as claiming that all the lexical semantic features are at the same time functional and head syntactic projections, which is not far from some of the recent syntactic theories (e.g. the cartographic approaches like Cinque 1999 or the yet unpublished 'nanosyntactic' work of M. Starke). In this way the boundary between the Lexicon and the real world knowledge becomes elusive.

By introducing the predicate *add_to*, I have split the predicate *lead_to* into two parts. Having introduced the general view on the predicate *add_to*, I now concentrate on the remaining component, i.e. the one that relates the two subevents of the telic template.

What is minimally required to hold between an initiating and the result subevent is for them to be ordered in such a way that the initiating part comes before the result. Ordering of this kind corresponds to the relation of asymmetric concatenation. Ergo, the second component of the predicate *lead_to* concatenates two predications into a larger structure. This concatenation is asymmetric, or directed, since it always concatenates the result subevent *after* the initiating one. The notion *after* is used here in a general ordering sense and not as a temporal relation (I am more explicit about the temporal interpretation in Chapter IV, section 2). The predicate therefore marks the fact that two subevents are in a relation in which the end of one of them is adjacent to the beginning of the other (see Krifka 1998 for a more precise definition of concatenation). I represent this concatenating predicate as *concat*.

Now I can replace the predicate *lead_to* with the cluster of two predicates *add_to* and *concat*. The predicate *add_to* can appear not only in telic eventualities, but also in atelic ones involving a process, while the predicate *concat* can only appear in telic eventualities, since it joins two subevents into a telic structure. In this way we arrive at the structure in (117). Now we can deal with the next question: how can the same head host three very different predicates: the lexical predicate (predicate₁), the functional predicate of a process (*add_to*) and another functional predicate that relates two predications (*concat*)? The problem has one particularly striking dimension: the predicate *concat*, which relates the two subevents with respect to each other, appears as a part of one of the subevents.

⁴⁰ Observe that the predicate *lead_to* establishes interpretation with respect to another subevent, while the predicate *add_to* rather relates to a property within the semantic domain of the eventuality in which it appears.

(117) Full template of eventuality with the predicates *add_to* and *concat*

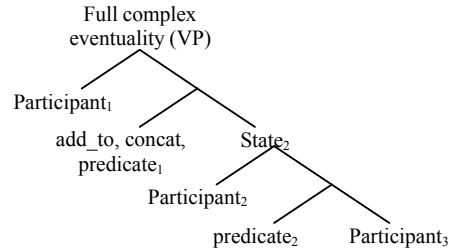

The natural move is to split the problematic head and make a more explicit representation of the interpretation that is assigned to the template. In this representation, the telic template is a phrase that takes predications as arguments and is headed by the predicate *concat*. The initiating subevent appears in the specifier position and the result subevent appears in the complement. This is shown in (118).

(118) Telic template: concatenating a process and a state

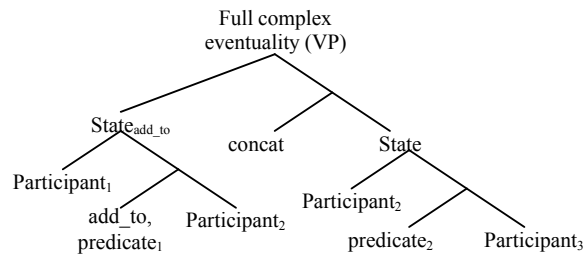

The predicate *add_to* is in the head of one of the concatenated states, more precisely the one that comes first in the concatenation, and it appears there together with some lexical predicate. The specifier of the VP ‘contributes’ the predicate *add_to* (the dynamicity) to the eventuality, in relation with some property of the complement of the phrase (i.e. specifies that this property changes). The lexical predicate that appears in the same head is interpreted as a kind of a modification of the predicate *add_to*, which specifies the property of the complement that is changing its value and/or the way in which the change is initiated.

The aggregate interpretation is that the complement of the phrase headed by the predicate *concat* is ordered after the specifier, and this is a crucial component of the initiate-result relation between the subevents. The initiating subevent is headed by the predicate *add_to*, possibly together with some lexical predicates. It specifies that the participant generated in the specifier of this subevent (*Participant1*) is the source of the dynamicity. This dynamicity adds a certain relevant value to some property of the participant in the complement of this subevent (*Participant2*). At some point in time, the property in question reaches the value specified in the result subevent.

The predicate *concat* is necessary but not sufficient to derive the meaning of the initiate-result relation. A bare ordering between two simple eventualities does not necessarily mean that one of them initiates the other and that the other is therefore its result. The additional ingredient of the template that conspires with concatenation

to derive this relation is the identity between the complement of the higher subevent and the specifier of the lower one (marked as Participant₂). The complement of the initiating subevent is not the result subevent, as was the case in the originally proposed template, but in fact the participant that appears in the specifier of the result subevent. The aggregate interpretation is as follows:

- 1) In one subevent (State_{add_to}), the value of a certain property of one of the participants (Participant₂) undergoes a homogeneous accumulation;
- 2) This value accumulation is specified through the predicates which are contributed by the other participant of the subevent (Participant₁); these predicates crucially include the predicate *add_to*;
- 3) The subevent in which the initiation and the process are taking place (State_{add_to}) is ordered before another subevent (State);
- 4) This other subevent (State) involves the same participant that had a property undergoing value-accumulation in the first subevent (the coindexed Participant₂);⁴¹
- 5) It (the State) defines a certain value for that property;
- 6) This value is defined with respect to a third participant (Participant₃).

From now on, I will be using the label *VP* only to denote the telic eventuality, i.e. the structure corresponding to the telic template, which involves a concatenation of two states. For stative eventualities and processes I will be using the label *State*, denoting a simple eventuality that can appear alone or as an argument of the VP.

As will be shown in the rest of this chapter, none of the properties of the structure which derive the listed steps is stipulated. They are all, from the point of view of grammar, just accidental properties of the structure, and the structure is thus an accidental one and not a template that is defined in the grammar. Structures without some of these properties are possible, and they do appear in natural language. The fact that exactly this structure received the status of a template in grammar is probably motivated by its pragmatic aspects. This structure derives the meaning of change, which is at the formal semantic level a meaning like any other. In language use, however, the meaning of change, with its starting and ending value, appears very frequently. This frequency of use might have triggered the grammaticalization of the lexical entries associated with these meanings, leading to the appearance of functional morphemes linked with the relevant semantic structure. In other words, the telic template is an interesting case within the wide range of possible structures, and not a rigid form that is imposed onto the structure of VP. Its status in grammar, though quite universal in languages of the world, is not a universal of language, but rather a consequence of its frequent use, which is essentially pragmatic.

Let me illustrate the semantic components of the interpretation of the telic template listed above with a real sentence. Observe the example in (119).

⁴¹ Coindexing is supposed to mark that the arguments in the two positions are coreferential. Bearing in mind that these structures represent meanings, it suffices that the two positions are filled with exactly the same semantic material. One instance, or both, may have a reduced lexicalization, or even be elided, but this goes beyond the domain of interest of this dissertation.

(119) Expanded telic template for ‘John pushed the cart to the shop’

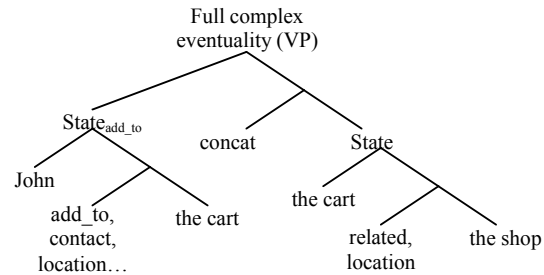

In this example, John initiates a process which affects the location of the cart. This process is immediately followed by a state in which the location of the cart has the value ‘at the shop’. This illustrates how the combination of the predicate *concat* and the identity of the complement of the initiating state with the specifier of the result state (i.e. the Undergoer) together derive the meaning of change. If this same property of the participant is ‘added to’ in one state (the initiating state) and has a certain value in another which immediately follows it, i.e. the result state, then this property changes its value to the one specified in the result subevent.

The set of predicates in the head of the result subevent (State) corresponds to the lexical meaning of the preposition *at*. This preposition is phonologically realized as *to* when heading the result subevent of a telic template. The property of the Undergoer that reaches its result value in this subevent is determined by the *location* component of this head. The value of this property is determined by the component *related* in the same head position, which specifies that the property of location of the Undergoer is related to the Goal, i.e. the shop. The fact that the predicate *related* in fact operates over the predicate *location* signals that a further decomposition can be pursued within each of the states. Since it is not directly relevant for the problems treated in this chapter, I will not go into a further discussion on this point.

The set of predicates in the head of the initiating state is lexicalized as the verb *push*. As discussed in 4.7 and 5.4, the meaning of certain verbs, like *kill*, *create* or *straighten*, involves a combination of predicates from the head of the initiating state with the Goal participant in the complement of the result state. (for instance *kill* involves both the result of someone being dead and the process that initiates this result). The predicate *location* in (119) determines the Undergoer’s property whose value is changed, and the predicate *contact* (probably a number of other predicates should be included here) specifies the way in which it is done. The different interpretation of the predicate *location*, on the one hand, and the predicates *add_to* and *concat* (and other possible predicates that the meaning of pushing can be decomposed into) on the other, indicates the necessity of an even deeper decomposition in this domain. For reasons of simplicity in presentation, I refrain from pursuing a deeper decomposition than that in (119).

The ways of deriving different types of argument structure, such as unaccusatives and unergatives, which are discussed in the beginning of this section, are still the same. Moreover, some facts about them can now be more strongly motivated.

For instance, it is now much clearer why the telic template is so bad if the Undergoer is not overtly specified. Without a specified Undergoer, the template

cannot be formed, because the Undergoer is part of its definition (through the requirement that it appears in two different positions of the structure). In fact, as I argue in 3.6 and 3.7, not only must the Undergoer be present, but it is also subject to certain syntactic and semantic constraints.

2.3. Summary

In this section I briefly summarized the model introduced in Chapters I and II. This structural model consists of two phrases, one of which is projected on top of the other. The lower phrase represents the result state and the higher one represents the initiating state. The head of the higher phrase bears the predicate *lead_to*, which introduces dynamicity and derives an initiate-result relation. The specifier of the higher phrase is the subject of initiating and its complement is the result state. This derives an interpretation in which the Initiator participates in some predicate that leads to the result, which corresponds to predication in the lower phrase.

Different underspecified variants of this structure represent different special argument structures, such as unaccusatives and unergatives. When the structure is full, i.e. when neither of its two phrases is un(der)specified, the derived eventuality will be telic. When one entire phrase is unspecified, the derived eventuality will be atelic.

I pointed out some conceptual questions that the model faces, most importantly the grouping of the unrelated predicates in the head of the template. To solve these problems, I proposed an extension of the model. I split the predicate *lead_to* into two predicates. One is the predicate *add_to*, which contributes dynamicity, and the other is the predicate *concat*, which relates the initiating state to the result state.

The extended model consists of three phrases, structured such that two of them are the arguments of the third. The third phrase is headed by the predicate *concat*, which simply concatenates its two arguments. The two phrases that appear as arguments of the third one represent states. The one that appears in the specifier is headed by the predicate *add_to*, possibly in combination with some other predicates. The interpretation of concatenation is closely related to the coreference between the complement of the state in the specifier and the specifier of the state in the complement of the *concat* phrase, an aspect that receives a detailed elaboration in section 3. The *concat* phrase is identified with the VP.

With the definition of the template presented, thematic roles like Initiator, Undergoer and Goal become theoretically redundant. Their interpretational properties are now read off the structure, which was one of the aims of the dissertation formulated in Chapter I. One of the functions of thematic roles in Krifka (1998) was to specify whether the reference type of the relevant argument will have effects on the reference type of the eventuality. In the next two sections I present how these aspects can be accounted for without resorting to thematic roles.

The template defined in this way represents telicity as a semantic property. Telic eventualities are complex: they consist of two simple eventualities. Telicity is identified with involving a result component, and effects of temporal intervals, properties of arguments and different modifiers are ignored. This realizes the split between two types of inner aspect that was suggested at the very end of section 4 of Chapter II. The next section will elaborate on this split, providing accounts for both recognized types of inner aspect.

3. Quantificational aspects

3.1. Introduction: inner aspect and core telicity

So far three points are defined as crucial for the telic template:

- 1) the predicate *add_to*, which brings in the process (dynamic) interpretation.
- 2) the predicate *concat*, which contributes to the initiate-result component.
- 3) the coreference between the complement of the initiating subevent and the specifier of the result subevent; this component completes the initiate-result interpretation resulting in the meaning of a change in a certain property of the corresponding participant.

In this subsection, I introduce the core of a novel approach to the inner aspect and the so-called tests for telicity. It further develops the view of inner aspect that divides it into two different notions, one of which will be referred to as telicity, and the other as inner aspect. Though closely related, the distinction between these two notions leads to important theoretical advantages in the research of aspect. While telicity only relates to the resultative component, i.e. to whether an eventuality consists of two subevents, inner aspect involves, and directly relates to, an additional semantic component: quantification.

I argue that just as nominal predicates, eventualities may involve quantification, and that inner aspect is in fact a property related to the presence or absence of quantification over the eventuality. Inner aspect only indirectly and partially reflects telicity, which is an effect of the decompositional structure. In this respect, I present the structure of the VP as fully parallel to that of the NP, in particular to the one proposed in Borer (2005a). I show that, semantically and syntactically, the telic template directly corresponds to the domain of grammatical number in the NP (they both introduce the property of countability to the predicate of their respective expression), and that inner aspect corresponds to quantification in the NP.

This means that I extend the model of the semantic and syntactic representation of eventualities presented so far by adding one more component, quantification. Crucially, this quantification is not assigned to eventualities by some other elements, but base-generated on the VP representing an eventuality. This does not present a radically innovative step even within the decompositional approaches in the field. Approaches such as Di Sciullo & Slabakova (2005) or Zhang (2002) argue for the important role of quantification as directly generated on the eventuality and not necessarily transferred from one or more of its arguments. The model I present, however, offers an explicit and complete representation of this aspect of the VP.

Quantification over the eventuality is introduced in a projection immediately over VP, which I label QP, as in (120). QP is headed by the same quantificational predicates that figure in nominal quantification. The parallel between quantification over eventualities and nominal quantification is complete: both involve functional projections which introduce quantificational predicates to the structure over which they project (for the structure in the nominal domain, see for instance Zamparelli 1995 and Borer 2005a). In many languages, including English, the quantificational layer over the eventuality has no overt realization, but may be reflected through quantification over the nonspecific arguments of the eventuality.

(120) Extended model: a quantified VP

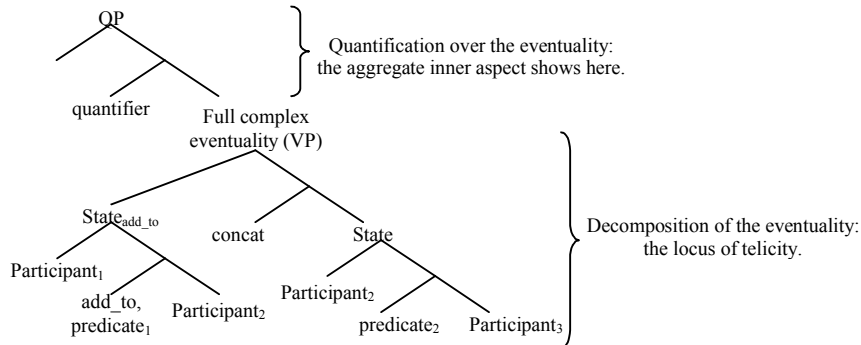

In the remaining of the dissertation, I use the terminology as in (121).

(121) a. Telicity, taking two values:

- 1) atelic – corresponding to simple eventualities, nonculminative concepts;
- 2) telic – corresponding to the telic template, culminative concepts.

b. Inner aspect, taking two values:

- 1) homogeneous – combining with *for*-phrases and not with *in*-phrases;
- 2) non-homogeneous – combining with *in*-phrases and not with *for*-phrases.

Telicity relates to whether the eventuality involves two subevents organized in a telic template, i.e. whether its interpretation involves the initiate-result component. Inner aspect relates to the quantificational, and therefore also mereological, properties of eventualities, which are attested in tests of inner aspect (traditionally also called tests of telicity, but this term may involve confusion in the terminological division that I just introduced). I chose the values homogeneous and non-homogeneous because the question whether divisiveness and cumulativity have to go together is subject to debate (see section 4.5 in Chapter II).

Once the representation of an eventuality is supplied with quantification, it should display some interaction with the (lack of) quantification over the participants that are embedded in the eventuality. Such interactions, which especially involve distribution and scope, often appear between quantifiers within the same clause or within an even smaller domain such as the VP. I argue that this is exactly how the well-known dependencies between inner aspect of the eventuality and the quantificational properties of the participants are instantiated. Furthermore, in at least some cases, the present model analyzes the quantification on the participants as a reflex of the quantification over the eventuality.

The general view that correlations between the quantificational properties of an eventuality and the quantificational properties of its arguments are a consequence of distribution between quantified expressions has already been proposed in Jackendoff (1996) and Ramchand (2002). To my knowledge, however, no explicit technical elaboration of these ideas has yet been proposed in the literature.

I first discuss how and why participants of an eventuality receive their quantification from the quantification over the eventuality. I show that this effect relies heavily on the nonspecificity of the NP representing the relevant participant.

3.2. Nonspecific arguments in telic eventualities

In this subsection I first briefly present the phenomenon of specificity and then concentrate on the global picture of its interaction with the quantification over the eventuality. The aim is to present a certain type of binding by higher predicates that only nonspecific arguments of an eventuality may undergo. My major point is that, as already suggested in 2.2, predicates of arguments that are specific do not interact with the predicate of the eventuality, or those projected on top of it. This is because they establish reference independently of the eventuality in which they appear as arguments. No such barrier is present in the predicates of nonspecific arguments, which do not involve any deictic component and therefore can be bound by the higher predicates. I propose a particular technical account for how and when this binding occurs, which also provides additional explanation for why exactly nonspecific arguments are available for this type of binding. In this domain, I concentrate on those aspects that I find relevant for the way inner aspect of an eventuality correlates with the quantificational properties of its participants. A broader discussion of this view of notion of specificity, which differs from the tradition building on Enç (1991), can be found in Sio (2006).

With respect to the way they establish reference, NPs can be *specific* or *nonspecific*. One way to define specificity is through the level of freedom in establishing reference: an NP is specific in a given context if a) the lexical component of its predicate (i.e. ignoring the components of specificity and quantification), determines a set that includes the referent of the NP as one of its members, and b) the NP nevertheless cannot refer to just any member of this set: its referent is unambiguously determined in the context. Unlike nonspecific use, specific use of NPs normally requires that at least one of the interlocutors knows a definite description, true of the referent that the NP refers to. This is illustrated in (122).

- (122) a. John saw the car.
 b. John saw a certain car.
 c. John saw some car or other.

The sentences in (122a, b) have specific direct objects. The specificity of the object in (122a), which is also definite, entails that it is a particular token of car that John saw, and that this token is determined independently of the sentence. This is natural because, being discourse-old, the referent was known to all the interlocutors before the sentence was uttered. The sentence in (122b) also has a specific indefinite direct object. There is a particular car to which the relevant NP refers, although it is not known by (all of) the interlocutors which exact car this is. Yet, the particular car still has to establish reference independently of the sentence in which it is uttered. One or more of the interlocutors, or perhaps only John himself, was able to identify the particular car that the sentence is talking about even before the sentence was uttered.

The sentence in (122c), as opposed to the other two, has a nonspecific direct object. It states that John saw some car, and due to the singular of the argument NP, there is one particular car that John saw in the eventuality that the sentence refers to. However, this particular car cannot be identified independently of the eventuality in which it was seen. Without this eventuality, the nominal expression *some car or*

other refers to any car in the world. Only through the eventuality it gets a definite description (the exact car seen by John in the eventuality referred to in the sentence).

The point I want to make is that nonspecific arguments are referentially bound by the eventuality in which they appear. Their participation in the eventuality makes them specific for the further discourse, acting as a definite description. The particular referent of the NP is bound by the predicate of the eventuality, abstracting away the bound participant. This binding is even more obvious, if the eventuality distributes over some other referent. In (123), the eventuality is distributed over reference times, which are under universal quantification.

(123) Every time John drives someone else's car, he has an accident.

This sentence can be paraphrased as follows: for every eventuality in which John drives a car that he does not own, there is an eventuality of John having an accident. This distributive reading for the two eventualities requires that there is an epistemic evaluation time (a temporal interval in which it is evaluated whether the sentence is true) for each pair of instances of the two eventualities. For every different epistemic evaluation time, there has to be a reference time. And at each of those reference times, there is a referent that can be described as a member of the set of cars that do not belong to John and as the car that John is driving at the reference time. Each particular instance of the eventuality involves one car from the set of those that do not belong to John. The exact car is determined as the one involved in the particular instance of the eventuality. This means that the reference time referentially binds the eventuality, which in turn binds the nonspecific argument *someone else's car*.

In this view, a nonspecific participant can be seen as a locally bound variable: it is bound by the closest available quantified element. This can be the eventuality, as in (122c), or, though indirectly, the reference time as in (123). If bound by a specific element, this argument naturally also becomes specific in the discourse, as is the case in (122c). Independently of the eventuality, the NP cannot establish a unique reference. The eventuality provides, or mediates in providing, the nonspecific NP with a definite description. Assuming that the nonspecific argument is derived in the Undergoer position, this yields the form of the template in (124).

(124) Telic eventuality template with a nonspecific Undergoer

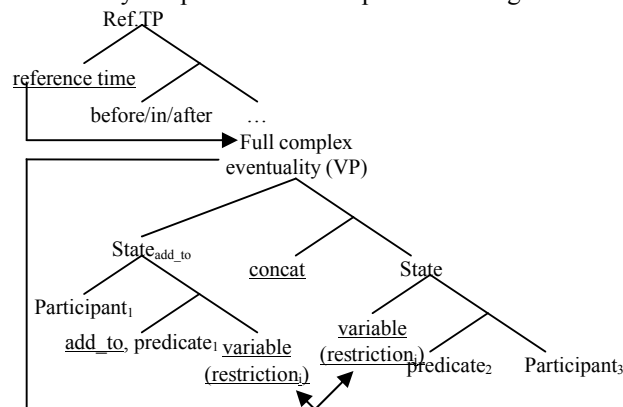

The nonspecific participant, here the Undergoer, is represented as a variable with a certain restriction. The restriction is in fact the property denoted by the nonspecific NP. Hence, the restriction denotes a set, and the Undergoer may refer to any member of this set. In (122c) this is the set of cars and in (123) the set of cars that do not belong to John. The variable in the Undergoer positions is bound by every predicate that c-commands them both, and which is of a kind that is absent from the predicate of the NP. For instance, if, like in (123), the NP lacks quantifying predicates, and the closest quantifying predicate in the c-commanding structure appears in the reference time argument like in (124), the quantifying predicate of the reference time argument will bind the NP (via the eventuality, which also lacks a quantifying predicate). This leads to the distribution of the Undergoer over reference times. The same goes for the predicates of specificity and definiteness: if present in the higher structure, they will bind all the c-commanded NPs that lack these predicates.

If two or more nonspecific elements are present inside the VP, and if they have the same restriction, they will come out as coreferential. This is due to the fact that since they have the same restriction, they determine the same set within which they may refer, and since they share all the same binders, they pick out from that set the same referent. The properties of the telic template are therefore preserved, including the coreferentiality of the two positions in which the Undergoer is generated.⁴² Without this property, if there were no guarantee that the two argument positions involve reference to the same participant, two orthogonal predicates would be concatenated, which does not derive the interpretation of initiating a result.

This illustrates one more property of the telic template. The predicate of concatenation can in fact be presented as a mere sum. I assume the standard definitions of the operations of sum and concatenation, like for instance used in Krifka (1998), where concatenation is a sum of objects that are adjacent and therefore do not have shared parts or intersections. The concatenation interpretation in the template comes from the identity of the two relevant participants in the states that undergo the sum. The two states undergoing the sum assign two different values to one and the same property of two referents. If these two referents happen to be coreferential, then the two states cannot hold in the same temporal interval, which means that their sum can only be formed as a concatenation.

(125) a. Head of VP contains the predicate *sum*; the interpretation of concatenation is derived by the fact that the two summed states cannot overlap since they share one argument, but assign different values to one of its properties; the ordering is structurally encoded in the specifier-complement asymmetry.

⁴² In Chapter II, section 3, I discussed the theory of event structure proposed by Krifka (1992, 1998). Among the most important relations that this approach postulates between eventualities and their participants is the uniqueness relation. A thematic role can specify that a certain participant shows uniqueness for a certain eventuality, and that an eventuality shows uniqueness for one of its participants. The account introduced here generalizes both these relations for all nonspecific participants: whatever participant is denoted by the nonspecific NP generated in some position, it is unique for one instance of the eventuality derived by the VP. In order to have more than one instance of a countable eventuality for the same referent appearing with the same way of participating, the participant must be specific and the eventuality quantified in the relevant way, i.e. it has to be overtly marked in the structure of the VP. Krifka's notion of uniqueness is slightly different, because it also involves the pragmatic knowledge about concepts like creation or consumption.

b. The telic template with the predicate *sum*.

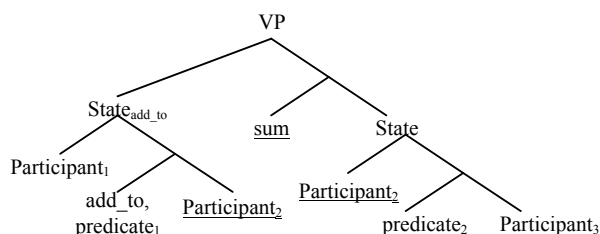

Back to the effects of specificity, for the reasons presented above, related to the special properties of the projections headed by deictic predicates and the particular kind of binding of a predicate into its c-command domain, it is expected that specific nominal expressions show no interactions with the predicate of the eventuality, or with the higher predicates in the structure. Nonspecific arguments are expected to be bound by predicates of specificity and definiteness, which is confirmed by the fact that a nonspecific nominal expression used in a specific eventuality receives the status of a definite for the further discourse, like in (126).

(126) A: John saw some car or other and went home.

B: Was the car yellow?

Furthermore, we expect that if a nominal expression is base-generated as nonspecific and without predicates of quantification, and a predicate of quantification is present in the c-commanding structure, this quantifying predicate will bind the nominal expression, which is then interpreted as distributed over instances of the referent that involves the quantifying predicate. I will argue that this is exactly how the effects of correlations between inner aspect and the properties of arguments emerge. Moreover, I will argue that binding of the described type is the structural mechanism in which all distributive readings of nonspecific expressions are derived.

3.3. Correlations between inner aspect and the arguments of an eventuality

Let us consider the consequences of the view presented above for inner aspect. It has been observed, at least since Verkuyl (1972), that the inner aspect of an eventuality correlates with some quantificational properties of its participants. As shown in (127), if in a sentence with a telic non-homogeneous eventuality, one of the participants is replaced with a bare plural or with a mass noun, the tests indicate that the eventuality is homogeneous.

(127) a. John pushed the cart to the shop in ten minutes/?for ten minutes.

b. John pushed the cart to shops for ten minutes/?in ten minutes.

c. John pushed carts to the shop for ten minutes/?in ten minutes.

Many linguists (including Verkuyl 1972, 1993; Krifka 1992, 1998 and Borer 2005b, see Chapter II) have developed accounts in which the inner aspect of an eventuality is sensitive to the (properties of) quantification over the participants in that eventuality. They assume that this quantification is always determined independently of the eventuality, and that the relevant NPs are generated in the relevant position in a VP fully specified for its quantificational properties. The eventuality

itself is not considered to have proper independently generated quantification, although some sort of quantification can be introduced through temporal adverbials of quantification, as in (128).

- (128) a. John pushed the cart to the shop twice.
 b. John pushed the cart to the shop several times.

In this section, I present an account of the relation between inner aspect and the quantification on its participants that takes the opposite direction. I argue that predicates of eventualities may involve independent quantification, in the same way as nominal expressions do, and that this quantification may bind the nonspecific arguments of the quantified eventuality. This binding may leave a trace in the form of a lexicalization of the binding quantifying predicate on the bound nominal.

I also argue that the so-called tests for telicity only diagnose quantification over the eventuality, and not telicity as defined in this chapter. Because the quantification diagnosed by the tests can be reflected on the nonspecific participants of an eventuality, although this is not where it is base-generated, the impression is created that the quantification of participants has an effect on inner aspect. The effects actually go the other way around: the quantification of the eventuality, responsible for the effects of inner aspect, is lexically reflected on the NP(s) of the nonspecific argument(s) that it binds.

Crucially, this means that the semantic input to the syntactic module, in a production-oriented model, may contain a quantificational specification of the eventuality, just as it may contain a quantificational specification of the nominal arguments of that eventuality. Both inputs, of course, can also remain quantificationally unspecified, in which case homogeneous meanings are derived.

Let us start from the facts illustrated in (129), which show that the inner aspect of an eventuality manifests no sensitivity to the quantificational properties of its specific arguments, but only to the nonspecific ones.

- (129) a. John pushed the five carts/the carts to the shop in ten minutes/?for ten minutes.
 b. John poured the water/the five glasses of water into the barrel in ten minutes/?for ten minutes.
 c. John pushed some particular three carts/some particular carts to the shop in ten minutes/?for ten minutes.

The quantification over the definite and therefore also specific NPs in (129a-b) has no effect on telicity. The same holds for the specific indefinite NP in (129c), if the interpretation is excluded in which only the kind of carts is specific and not the actual referent. Whether they involve numerals, quantifiers or just definite or specific plurals does not matter for inner aspect: the eventualities are non-homogeneous. Traditionally, this has been treated in the following way (e.g. Verkuyl 1972). It has been observed that specific NPs cannot have homogeneous predicates, and that they can only be bounded, irrespective of the remaining parts of their predicates. All a theory needs to do, is establish a relation between the nominal expression and the eventuality, and once this is done, specific nominal expressions will correspond to the bounded, i.e. non-homogeneous, interpretation of the

eventuality. The relation established between the eventuality and its arguments is bidirectional: properties of eventualities may transfer onto the arguments and properties of arguments may transfer onto the eventualities in which they appear. I present an alternative explanation, which is theoretically simpler, arguing that the relation between the eventuality and its arguments goes in only one direction: predicates of the eventuality can bind its arguments. This leads to a less costly theory, in which only one tool: predication into the c-commanded domain, is used to account for all the effects of correlations between the inner aspect of the eventuality and the surface forms of nominal expressions representing the arguments.

In the approach defended here the observed behavior of specific arguments means that specificity presents a barrier that blocks the quantificational and specificity-related predicates of the NP from interacting with the corresponding predicates of the eventuality. In other words, being generated as specific, the NP cannot be bound by any of the predicates of the eventuality. Only nonspecific NPs can therefore be bound by the eventuality, and only nonspecific argument NPs ensure a real correlation between their quantificational component and the inner aspect of the eventuality. And indeed, while specific NPs always correlate only with the non-homogeneous inner aspect, nonspecific NPs, which can be either homogeneous or non-homogeneous, correlate with both values of inner aspect. To sum up, comparing the examples in (129) to those in (127), we reach the conclusion in (130).

(130) Only the quantificational properties of nonspecific participants in an eventuality display correlations with inner aspect.

So far, this approach can be taken as a purely theoretical turn, which captures the facts as well as previous theories. One of the goals of the remainder of this chapter is to illustrate both the theoretical and the empirical advantages of this approach. First, however, I provide a more detailed picture of the approach itself.

As observed above, nonspecific participants are bound by the structure in which they are embedded. This may yield three types of cases:

1. The nonspecific participant has no quantification and no grammatical number of its own and therefore receives both properties from the eventuality in which it appears. (Issues of grammatical number in the domain of eventualities are discussed later in this section.)
2. The nonspecific participant has its own grammatical number, and is bound only for quantification.
3. The nonspecific participant is specified for quantification, and only lacks specificity and definiteness, so it gets bound by some higher structure which is specified for these properties, usually the reference time.

Let us look again at the structure in (120), repeated in (131), and see how it can be used to represent the binding relations between argument NPs and the higher predicates, in particular the quantifier over the eventuality.

(131) Extended model: a quantified VP

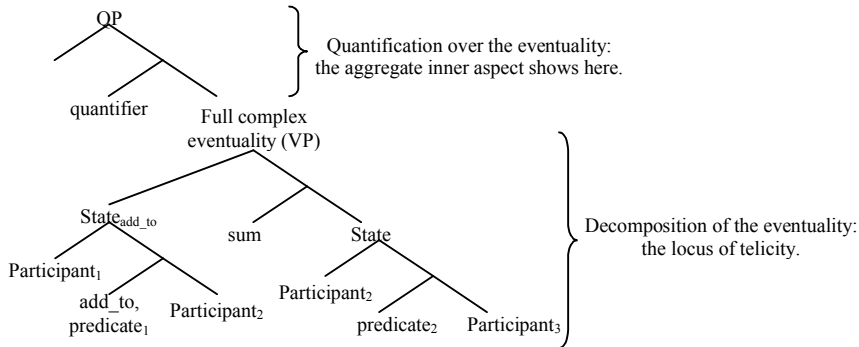

Let us take an eventuality in which one of the participants is a variable, and let the variable participant be the Undergoer. The structure will be as in (132).

(132) Quantified template

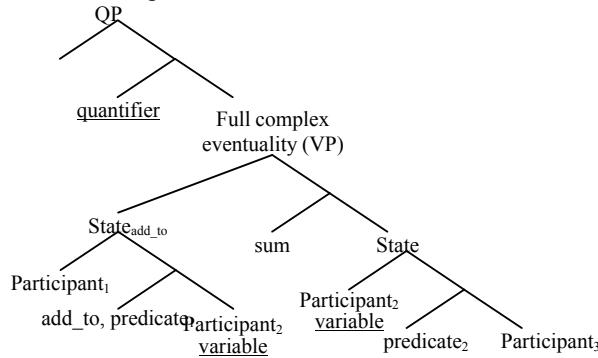

In this situation, the fact that the Undergoer is a variable means that it is nonspecific and crucially non-quantified. It therefore appears as a variable with respect to quantification and is bound by the quantifier over the eventuality. If, as it is the case with English, the language in question does not have morphemes which can lexicalize quantifiers over eventualities, it will not be possible to mark overtly that a certain structure involves quantification over the eventuality. However, in a case such as the one presented, in which the quantifier binds a NP inside the eventuality, the problem can be avoided by lexicalizing the quantifier on this NP. When the sentence is interpreted, the nonspecificity of the NP creates an ambiguity: the quantifier that appears on the NP may be interpreted not only on the NP, but also on the predicate of the eventuality.

In general, there are three interesting ways for this kind of binding to be reflected in the sentence. One is that an overt quantifier is generated in the QP that gets a reflex on one or more nonspecific participants, as in the example in (133a) for the reading in which there are three eventualities of eating a single sandwich. This also applies to the eventuality in (134). The second way is to have a singular eventuality; then, the relevant participant(s) surface(s) in the singular, as in (133b). Finally, it is possible that there is no quantificational predicate at all, in which case a bare VP is

projected. As discussed below and in section 3.8, a bare VP corresponds to a bare plural in the nominal domain. This level also has the potential to bind nonspecific participants, provided that they lack grammatical number, and these participants can therefore surface as bare plurals, as in (133c).

- (133) a. John ate three sandwiches.
 b. John ate a sandwich.
 c. John ate sandwiches.

A structural representation of a typical example is represented in (134).

- (134) Quantified VP of ‘John pushed three carts to the shop’

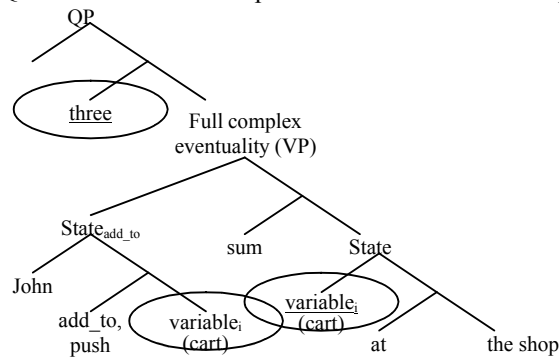

The quantifier *three*, which is base-generated to quantify over the eventuality, at the same time binds the variable inside the eventuality (the Undergoer, *cart*). How the Undergoer receives the plural ending will become clear in 3.8.

It is crucial for the structure above that the Undergoer is generated without the predicates of quantification and specificity. If it were generated as a quantified NP, it would not be bound at all, and the quantifier over the eventuality would be left without lexicalization, and therefore also without interpretation. The quantifier *three* in (134) has no overt realization in the position in which it is generated, i.e. in the predicate of the eventuality. It only has a reflex on the NP that it binds, which is its only lexicalization. The nonspecificity of the Undergoer preserves the information in the sentence in (134) that the quantifier may have originated at the eventuality level, in which case it quantifies over the entire VP and not only over the participant.

The fact that there is also an alternative structure available for the same sentence, i.e. that the quantifier *three* is base-generated on the NP, does not present a problem for this analysis. It simply represents an instance of structural ambiguity. The reading corresponding to this alternative structure is often referred to as the collective interpretation of the relevant NP. Finally, there is also a reading in which the phrase *three carts* is specific. In this case too, the quantifier is originally generated within the NP.

More complicated cases are possible as well, such as for instance one where a quantified eventuality involves more than one non-quantified nonspecific participant. In this case, there are two options for structural representation. One is that the quantifier appears on each variable NP, as in (135a). The other is that the quantifier is lexicalized on only one of the variable participants, while other such

NPs appear as definite and in the plural, and are interpreted as distributed over the NP that lexicalizes the reflex of the quantifier, as in (135b). I remain agnostic as to the way definite nominal expressions as in (135b) are generated and whether they distribute, noting only that this definite NP is similar to other types of non-discourse-old NPs with a definite article, such as *the car* in (135c).

- (135) a. John pushed three carts to three shops.
 b. John pushed three carts to the (respective) shops.
 c. A taxi-driver left the car and ran away.

In this subsection, I have proposed an extension to the model that introduces a layer of quantification over the VP. The motivation for this comes from the fact that eventualities can refer and reference is closely related to quantification (for instance, mass nouns and bare plurals cannot have specific indefinite reference). This implies that the conceptual representation of an eventuality may involve quantification, and consequently, when such a concept is sent to syntax – that it brings its own quantificational predicate. I have made a distinction between telicity and inner aspect by associating the latter with the layer of quantification, while telicity is linked to the structure of the VP. The quantificational layer over the eventuality is able to bind non-quantified NPs that represent the participants. I suggested that in such cases the quantifier over the eventuality can be lexicalized on the NP it binds. In the following two subsections, I argue that the VP corresponds to the bare plural in the nominal domain, as a projection determining that the derived predicate involves a unit of counting, at the same time specifying this unit of counting.

This simplifies the traditional view, by excluding any transfer of semantic properties from the arguments to the predicate of the eventuality. The only direction of transfer is from the eventuality to its arguments, and it takes place via the described kind of binding. Eventualities may or may not involve the quantificational predicate, which makes them non-homogeneous and homogeneous, respectively. As discussed in the next two sections, the only property of the remaining part of the predicate of the eventuality that has any effects on inner aspect is whether it involves the telic template, i.e. whether it defines the unit of counting, required by most quantificational predicates. Other properties of the predicate, including properties of the arguments, are orthogonal to inner aspect.

One potential problem for my approach originates from the fact that not all nonspecific NPs are generated as non-quantified. Consider the reading of (136a) with only one instance of the eventuality of eating, involving a participant that consists of three sandwiches. A more serious problem is that, at least at first sight, it seems that not all the non-quantified participants are bound by the QP (and the VP) of the eventuality. Observe in this respect (136b): in one reading there are three instances of the eventuality in which a single student drinks wine, but the nonspecific Undergoer still appears as a mass noun – not even as bare plural.

- (136) a. John ate three sandwiches.
 b. Thee students drank wine.

For the former type of cases (136a), the natural step is to consider that the quantifier is base-generated on the participant and not over the eventuality. But then

one should not expect that the quantifier on the participant has any effects on the inner aspect of the eventuality. I argue that this is a correct prediction and that the eventualities with quantified participants are, just as expected, ambiguous between the homogeneous and the non-homogeneous reading, i.e. between the singular and the bare plural interpretation. This is because the denotations of the specific and quantified NPs can be collectively bound by the bare plural of the VP and, if present, the (singular) quantificational predicate of the eventuality.

The latter type of problematic VPs (136b) has arguments surfacing in bare plural forms or as mass nouns, but they still allow a non-homogeneous (i.e. singular) reading. I argue, however, that in these cases the bare plural and mass NPs are introduced with a partitive meaning, and in fact embedded as partitive complements within the positions of the relevant arguments. They are thus not direct arguments of the VP and therefore they also do not get bound by the quantification over this VP. Together with some other questions, these problems are analyzed and discussed in the remainder of this section.

One could also object to the proposed analysis by saying that the relation between the nonspecific participants and inner aspect that I have attributed to binding could just as well be attributed to a distributive reading of the eventuality with respect to the participant. This objection is, however, vacuous because the mechanism I proposed is nothing more than a technical account of how one type of distributive reading is established. Furthermore, it is carried out in a very formal and explanatory manner, without a stipulated distributive projection or any other such tool.

3.4. Mereological relations

This subsection deals with the relations between the inner aspect of an eventuality and the mereological properties of the NPs expressing its participants. The discussion so far has presented one possible way in which this relation can be established directly by means of predicate-binding and quantification.⁴³ This differs from traditional views. Most authors who try to establish a semantic link between these two phenomena use the mereological properties of the predicates of units of these types (see for instance Krifka 1992 and 1998, Verkuyl 1993, Borer 2005b, introduced in Chapter II).

Mereological approaches are based on the properties of different predicates related to the part-whole relation between their arguments. At the core of most such approaches are two properties, divisiveness and cumulativeness, which are defined as in (137).

(137) cumulativeness: $\forall P.CUM(P) \Leftrightarrow [\forall x, y.P(x) \wedge P(y) \Rightarrow P(x \oplus y)]$; Krifka (1998)
A predicate P is cumulative iff whenever it holds for two entities x and y it also holds

⁴³ In this chapter, I emphasize the importance of the relation established between a certain predicate and a constituent that it c-commands, and which lacks the corresponding predicate in its structure. In such a configuration, the lower c-commanded constituent is fully dependent on the c-commanding predicate. For this relation, I use the term *binding*. This is, however, not the exact configuration usually referred to as binding, above all because binding takes place between referents and not predicates. Perhaps the proper term to use therefore is *predicate-binding*. I continue to use the term *binding* anyway, not only because it is shorter, but also because I do not exclude the possibility that various other instances of binding can also be accounted for in terms of the described configuration.

for their union (\oplus stands for the sum relation, an idempotent, commutative and associative function from the Cartesian product over a type, in this case the one of predicates, to the type itself: $UP \times UP \rightarrow UP$).

divisiveness: $\forall P. [\text{DIV}(P) \leftrightarrow [[\forall x. P(x) \Rightarrow \exists y. P(y) \wedge y < x] \wedge \wedge [\forall x, y. P(x) \wedge P(y) \wedge y < x \Rightarrow P(x-y)]]]$; Borer (2005b)

*A predicate P is divisive iff when it holds for an entity x, it also holds for at least one other entity y which is a part of x, and when P holds for x and its part y, it also holds for the complement of y with respect to x.*⁴⁴

Divisiveness and cumulativity relate to the predicates of both nominal expressions and eventualities. If both properties are absent, we speak of quantization and if they are present, of homogeneity. Predicates of telic eventualities are linked to the lack of cumulativity (Krifka 1998), or either (or both) of these properties (Borer 2005b).⁴⁵ It has also been observed by the same authors and by many others (see Tenny 1994) that there is a correlation between the presence of these properties in the predicate of the eventuality and its presence in the predicates of some of its participants.

Whether a predicate is cumulative or divisive depends crucially on whether it involves any quantification and, if so, what type of quantification. Since quantifiers tend to be phonologically realized on nominal expressions, the cited authors have all assumed that the quantifying predicates are generated in the NP and then possibly transferred onto the eventuality (see Chapter II, sections 3 and 4 for a more detailed presentation of the mereological approaches).

In my approach, in which inner aspect and telicity are two different phenomena, the transfer of quantificational properties takes the opposite direction. Quantification can freely be generated on the eventuality, but in many languages, it simply cannot be lexicalized in that position. It therefore requires some NP for a lexical realization. This is only possible if there is a NP that is bound by the quantification over the eventuality. The quantifier over the eventuality can therefore be reflected on the originally non-quantified nonspecific NP arguments of the eventuality.

All the tests for inner aspect, as discussed in Chapter II subsection 3.4, are based on the compatibility of different values of inner aspect with some predicates that project higher than the structural domain in which inner aspect receives its value. All four classical tests for inner aspect, represented in (138), involve temporal modification and probably also reference time.

- (138) a. John is pushing the cart to the shop. $-\rightarrow$ John has pushed the cart to the shop.
 b. John finished pushing the cart to the shop.
 c. John pushed the cart to the shop in ten minutes/?for ten minutes.

⁴⁴ With this definition of divisiveness, this property excludes atomic (minimal) objects from the domain of a predicate, just like cumulativity excludes maximal objects (every object satisfying a cumulative predicate can be summed up with another object that satisfies the same predicate).

⁴⁵ For Krifka, not all telic eventualities are non-divisive and non-cumulative: there are also other ways to derive telicity, such as delimiting the temporal interval of the eventuality. However, the most directly relevant case in the present discussion involves deriving Krifka's telicity from the mereological properties of the predicate of the eventuality and I most often only consider this case.

d. John pushed the cart to the shop on Friday and on Saturday. –
NON-AMBIGUOUS: 2 pushing eventualities.

This is most obvious for the progressive test in (138a), which is based on the aspectual difference between present or past progressive and present perfect. The aspectual verb test in (138b) involves an explicit ordering with respect to reference time, although it also detects more fine-grained aspectual classes, rather than mereological properties. The temporal adverbial test in (138c) clearly deals with reference time, just as well as the conjunction test in (138d).

The introduction of the reference time and its ordering with respect to the temporal interval of the eventuality takes place at a structural level higher than the quantification over VPs. It is probably one of the structurally lowest (and therefore most local) predicates that project over the QP and, naturally, interacts with the contents of the QP (a phenomenon traditionally described as selectional restrictions). In this view, the tests in (138) show the compatibility of inner aspect (QP) with some particular predicates projected on top of the relevant structure.

(139) The projection that represents outer aspect: immediately above QP

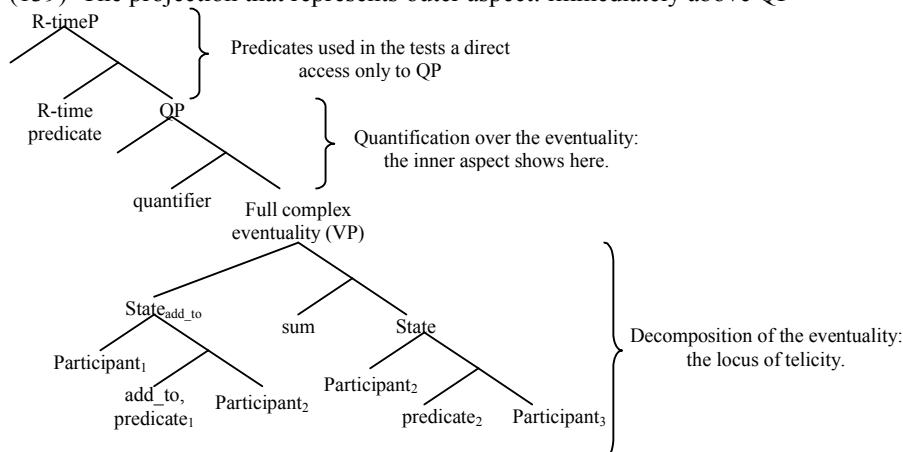

This means that tests for inner aspect only access the QP and that the structure lower than the QP can be ‘inspected’ only to the extent that it is reflected in the presence vs. absence of the QP, or in its particular contents. Therefore, if mereological properties are relevant for the results of the tests for inner aspect, they are read off the level of the QP, and not in the structure below this projection.

To be more precise, similarly to Borer (2005b), I relate homogeneity to the lack of any quantificational predicates, i.e. lack of a QP, and non-homogeneity to the presence of such a predicate, i.e. to the presence of a QP. Tests for inner aspect are sensitive to the presence of this projection. For instance, as argued for different reasons in Chapters IV and V, the progressive, the perfect, the perfective and the secondary imperfective all require the presence of a QP (they therefore sometimes force telic interpretations on expressions that are normally interpreted as atelic). Similarly, temporal *for*-phrases combine only with structures that already involve a quantificational predicate and *in*-phrases with those that lack one.

In this way, the division of aspectual phenomena in the VP in terms of inner aspect and telicity allows us to identify that the locus of the mereological properties lies in the quantification that the eventuality involves, rather than in any of the participants or in the decomposition of the eventuality. The fact that the mereological properties of an eventuality sometimes correspond with those of certain participants of this eventuality does not indicate that the properties of the participants are assigned to the eventuality. On the contrary, the properties of the eventuality are in certain cases assigned to the participants by the mechanism that has been introduced in this section. One exception, which is discussed in subsection 3.8, relates to quantified nonspecific NPs, which still have effects on the results of the tests for inner aspect, even though they are not bound by the quantification over the eventuality. Leaving this exception aside, divisiveness and cumulativeness are related to a level that is, both in syntax and in semantics, higher than that of core telicity. While telicity is related to whether the VP consists of two concatenated states or it involves only one state, the mereological properties of an eventuality depend on the quantification that can appear on top of this structure.

3.5. More on quantification

So far we have been dealing with two theses. One is that inner aspect directly depends on the quantification over the eventuality, i.e. that the presence of a quantificational predicate corresponds to a non-homogeneous value for inner aspect. The other thesis claims that this quantification can bind non-quantified nonspecific participants inside the eventuality. I argue that there is a very direct relation between the quantification over the eventuality and the decompositional domain to which I have attributed the derivation of telicity (taking telicity in the decompositional sense). More precisely, I argue that the telic template is a full counterpart of the nominal category of grammatical number, i.e. of classifiers. Both these categories have the effect of defining a unit of counting in the predicate in which they appear. While it is clear that this holds for the nominal domain, in this subsection I show that it is also true of the domain of eventualities.

Eventualities involving mass and bare plural participants (especially Undergoers) are usually treated as one class with respect to inner aspect. This is due to the fact that, as (140) shows, they behave in the same way when combined with so-called telicity tests. In the model introduced here, I relate the results of the type in (140a, b) to the homogeneity (i.e. combination of divisiveness and cumulativeness) of the eventuality, which is not the same property as atelicity. The behavior in (140c, d) is in this view also due to non-homogeneity, which should not be confused with telicity. Telicity and atelicity are reserved for complex and simple VP structures, respectively, and all the eventualities in (140) are telic.

- (140) a. John ate sugar for ten minutes/?in ten minutes.
 b. John ate sandwiches for ten minutes/?in ten minutes.
 c. John ate the sandwich in ten minutes/?for ten minutes.
 d. John ate three/many/less than five/some sandwiches in ten minutes/?for ten minutes.

I want to point out, however, that the two types of eventualities, those involving a relevant participant with a mass interpretation and those involving one in bare

plural, are not really that similar. The major difference between them lies in the fact that eventualities with a bare plural participant, as in (140b), have an additional interpretation, usually referred to as the iterative reading, in which there is an unspecified quantity of singular instances of the telic eventuality involving eating one sandwich, or an unspecified number of sandwiches. Eventualities with mass participants may be imposed iterative readings, but they are not really natural, and have to be forced by the context. In the present model, this means that the eventualities with bare plural participants allow for an interpretation in which the predicate of the eventuality corresponds to the bare plural interpretations and that this predicate may or may not bind the nonspecific participant *sandwich*, depending on whether this nominal is base-generated as a mass noun or as a bare plural. This means that there could have been exactly one, or twenty three such eventualities, or only a part of one instance of such an eventuality, or three whole instances and two thirds. This reading is more or less parallel to the possible (though dispreferred) reading of (140c) (with the *for*-phrase), in which *the sandwich* is taken as denoting a special type of sandwiches and eating one nonspecific sandwich of this special type appeared a number of times. This reading is more obvious in (141), where the same race can naturally be run more than once (although each time a different token, i.e. a different instantiation, of the race is involved).

(141) John ran that race for ten years.

Readings of the type in (141) are usually referred to as *iterative*. They are normally excluded when eventualities are tested for inner aspect. This is due to the fact that iterativity is traditionally assumed to be related to some higher structure than the VP (Ramchand 2002 relates it to outer aspect), and telicity is taken to be derived in the VP or immediately above it. Therefore, iterative meanings set aside, an eventuality as in (141) would be assigned degraded acceptability in combination with the *for*-phrase, and therefore be non-homogeneous. If on the other hand, as in (140b), an eventuality involves a bare plural, the availability of basically the same iterative type of reading (an unlimited number of instances of the eventuality) is considered a part of the paradigm of inner aspect, i.e. of the class of atelic eventualities. This suggests that the proper way of looking at inner aspect is to consider iterative readings part of the inner aspect paradigm.

Recall now that, in the present model, the property that is indicated by the tests for inner aspect is the presence or absence of the projection of a quantificational predicate over the eventuality. In the case of the iterative readings, which I have argued correspond to nominal bare plurals, the QP is absent and no quantification is specified. Just as with bare plurals, the iterative reading is homogeneous and can therefore combine with the *for*-phrase, and not with the *in*-phrase. In all the other tests as well, iterative readings display homogeneity.

Under the model of quantification over eventualities that is argued for in this section, the only difference between the two sentences in (140b) and (141) is that in the former, the relevant participant (i.e. Undergoer *sandwich*) is originally generated as mass and nonspecific. This allows the bare plural of the eventuality to bind this participant. The NP that represents this participant hosts the morphological reflex of the bare plural of the eventuality. In (141), the Undergoer is originally generated as

definite and can therefore not be bound by the predicate of the eventuality. The parallel between these two structures is represented in (142).

- (142) a. John ate sandwiches. = bare plural_i(John ate sandwich_i).
 b. John ran that race. (iter.) = bare plural_i(John ran that race)_i.

For the QP, I adopt the structure and interpretational properties of the quantifying predicates in the nominal domain, as presented in Borer (2005a). Borer proposes that nominal expressions have a structure that roughly corresponds to (143).⁴⁶

- (143) Borer's syntactic structure of a NP

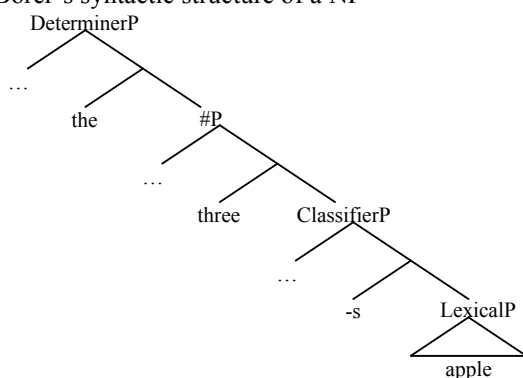

Observe the examples in (144).

- (144) a. There was dog all over the floor.
 b. There were dogs on the floor.
 c. There were five dogs on the floor.
 d. The five dogs were on the floor.

They illustrate, respectively, a nominal expression consisting only of a LexP (144a), one that, in addition, also has a ClassifierP (CIP) (144b), one with the LexP, CIP and the #P (144c), where #P realizes the quantifying predicate, and one with a full structure that also includes definiteness (144d). Their interpretations are as follows.

The meaning contributed by the Lexical Phrase (LexP) is interpreted as completely unstructured and unbound, i.e. with the properties of a mass. This is why bare nouns in English, appearing without any functional material (without even a plural ending or an indefinite determiner), as in (144a), have a mass interpretation.

The Classifier Phrase (CIP) introduces the aggregate set of possible divisions to this mass. Most properties of the mass interpretation are preserved, and the only difference is that the denotation is no longer taken to be completely unstructured: it involves all possible divisions – infinitely many – over the mass denoted by the LexP (possibly involving parts of potential canonical units of division).

⁴⁶ This is a somewhat rough representation of Borer's structure. For instance, Borer does not have any morphological material in the heads of the functional projections; instead the heads always have open values of the particular kind corresponding to the projection, which are then assigned range by the material in their specifiers or adjuncts. These issues are not crucial for the discussion and I have simplified the structure in favor of syntactic uniformity.

I refer to quantifiers that operate over a mass as mass quantifiers and to those that operate on a mass division as non-mass quantifiers.

Borer's theory is much more complex than presented here, and I am not committed to all its contents, but instead use its major elements to establish a parallel between the structure of a nominal expression and that of an eventuality.

Let us now transfer Borer's NP structure to eventualities. Eventualities, in the present model, appear to display exactly the same behavior as NPs, except that in English they have no lexical material to realize elements related to grammatical number or quantification (nothing parallel to the plural *-s* or to proper quantifiers).

In what follows, I draw a parallel between the effects of the nominal CIP and the predicate *concat* in the telic template, arguing that the concatenation of two states in one eventuality introduces a general division corresponding to the meaning of bare plurals. The parallel is represented in (148). Both these phrases introduce the aspect of a prototypical unit of counting (to which I refer as *canonical singulars*) into the predicate which is otherwise mass. The CIP in (148a) introduces mass division into the lexical meaning of its complement. This means that it imposes the infinite set of all the possible divisions on the predicate denoted by the LexP. The set of divisions imposed can be reduced by the classifier, or by the predicates in the #P. Concatenation in (148b) also derives a divided predicate, as opposed to a mass interpretation of the two states that are concatenated. Adjacency between the two states, i.e. the point of transition involved, entails that the meaning of the derived predicate involves units that correspond to canonical singulars in the nominal domain. If a bare telic template is taken to have an iterative reading, as in the present model, it involves units that are not specified for 'size' (i.e. they can have temporal intervals of different lengths) or cardinality (i.e. the iteration is unbounded). I further argue that these units can even involve incomplete parts of a single instance of the telic eventuality. This makes the parallel complete.⁴⁷

(148) a. Borer's CIP, under the #P

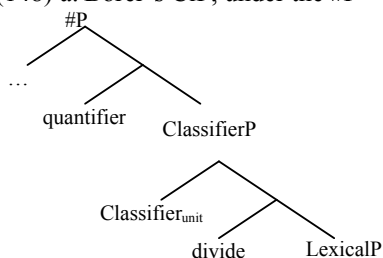

b. The parallel: a VP with a QP

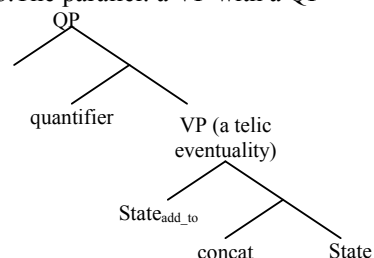

In addition, classifiers, in languages that have them, are often similar or identical to certain nouns, the difference mainly being the functional nature of their use. The

⁴⁷ Observe for instance that with the prototypical nouns like *apple* or *dog*, properties like size, shape, structure or different aspects of function determine the canonical singular component in the meaning of the noun; thus, *five apples* are five units of the mass of apple that have the prototypical shape, size and structure of apples. With deverbal nouns however, when derived from telic eventualities, the canonical singular is determined by the point of transition: *three killings*, *three murders* or *three deaths* involve three points of transition from the state of living to the state of being dead. See Arsenijević (to appear, b) for a detailed discussion of this question.

property that licenses their functional use is the semantic component specifying a unit as a base for counting. In a similar way, the state in the specifier of the VP is just like any other state: it can for instance project its own structure as an independent atelic eventuality. However, in order to appear in the specifier of the VP, it must also involve the functional predicate of dynamicity (*add_to*), which is a necessary ingredient in establishing the meaning of change in the telic template, and thus also in defining a phase transition.

Therefore, both the CIP and the VP derive a predicate that involves mass division. Although they do it in different ways, the parallel is still strong, as represented in (148). The concatenation in fact directly acts as a unit of division: a ‘linear grid’ of any possible number of single concatenations can be imposed over the two mass predicates that act as arguments of concatenation. The most important aspect for the current discussion is that in both cases, the division is unspecified, unbounded, and the single effect that it has is that a canonical singular unit is defined. In the VP domain, this unit is one single concatenation between a mass initiating subevent and a mass result subevent. Additional functional material, i.e. most directly the QP, can further specify this division, making it non-homogeneous.

So far, we can conclude as in (149).

(149) Atelic structures are represented only through one state and therefore have a default mass interpretation.

Telic structures involve a concatenation of two states, which defines a canonical singular, and derives a divided interpretation.

The most important aspect of the parallel between nominal expressions and eventualities discussed so far is that the bare telic template (the VP) can be seen as a bare plural in the domain of eventualities. Moreover, the fact that bare plural ensures that the predicate of an NP is homogeneous, is paralleled in the VP. This can be shown using the tests in (140) and (141), repeated here as (150a, b, d).

- (150) a. John ate sandwiches for ten minutes/in ten minutes.
 b. John ate the sandwich in ten minutes/for ten years.
 c. John ate three/many/less than five/some sandwiches in ten minutes/for ten years.
 d. John ran the race for ten years/in ten minutes.
 e. John ate a sandwich in ten minutes/for ten years. (*a sandwich* being nonspecific)

The parallel between the nominal bare plural and the property of iterativity in eventualities is now complete. According to this view, the non-iterative, and therefore non-homogeneous, interpretations in (150) (those that combine with the *in*-phrase) involve singulars of the respective eventualities.⁴⁸

⁴⁸ In (150a), the bare plural eventuality, together with the reference time, and therefore also the *in*-phrase, seems to be embedded under a habitual context. I refrain from discussing the structure that leads to the habitual reading, which means I must also leave the structure of this sentence unexplained. This complex structure, which might point to some aspects of the higher temporal domains in the clause, remains a topic for future research.

There are two ways in which the mereological effects of the telic template, i.e. the meaning of division, can be marked on eventualities. One is through the presence of the participants that can only be derived in telic eventualities, like Goals, resultatives or verb particles and the other is through the bare plural form of a nonspecific argument. Such a reflex is made visible in the contrast between (150a) and (150e), where one sentence involves a bare plural and the other a singular nonspecific participant. The different grammatical number markings on these two constituents result from different levels of specification of the original predicates in the nonspecific NPs. For the iterative reading of (150e), the NP *a sandwich* is generated with grammatical number and singular quantification. Due to involving its own predicates of grammatical number and quantification, the nonspecific NP is not marked for binding by the bare plural nature of the iterative reading of the eventuality. Reciprocally, for the single eventuality reading of (150a), the bare plural on the NP *sandwiches* does not originate in the predicate of the eventuality but is autonomously derived on the NP.

The sentence in (150e) is slightly odd under an iterative reading, but this is due to the pragmatic tendency to relate the Undergoer *a sandwich* to the same referent in each individual iteration of the eventuality. If the sentence is interpreted to mean that for ten years, John kept eating one sandwich in an unbounded number of instances of some relevant situation, the one that is very prominent in (151), it becomes fully acceptable. It seems that here the context has to provide a set of relevant reference times, or other referents, to referentially bind both the eventuality and its nonspecific argument in singular.

(151) John ate one sandwich for ten years, and then he started getting himself two.

As already shown, an analogous reflex on a nonspecific participant can be triggered by a proper quantifying predicate over the eventuality, which is projected over the VP as the QP. This is once more illustrated in (152). For the reading in which there were five eventualities of John eating a nonspecific sandwich, the quantifier that originates in the QP (as well as the plural marker triggered by the VP level) is lexically realized on the nonspecific Undergoer.

(152) 'John ate five sandwiches.'

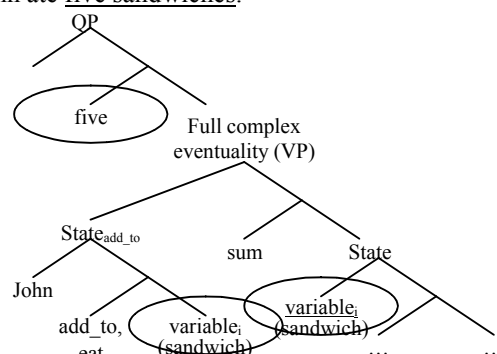

Eventualities involving a mass interpretation for the relevant participant differ with respect to the behavior discussed. The mass interpretation of the participant

reflects not only the lack of structure and of functional predicates on the NP itself, but also the lack of possible binders which are specified for predicates of the relevant type. A mass participant can surface in an eventuality only if the eventuality is atelic (so mass as well), or if it for some reason does not manage to bind the participant. That the latter option has to be considered as well is shown by examples such as (153b), where the meaning of the eventuality requires a telic template to be represented: some sugar has to end up being eaten in order for the sentence to be true. However, this telic template fails to trigger a reflex on the nonspecific mass NP realizing the Undergoer.

- (153) a. John loves sugar.
 b. John ate sugar for ten minutes.

Ignoring this problem, which is discussed in the next section, the model seems to successfully establish a relation between the decomposition of eventuality (including semantic notions like telicity and the initiate-result component) and mereological aspects of its interpretation (including the values of inner aspect). Telicity corresponds to grammatical number and forms a necessary requirement for more or less any quantification. Functional predicates of the eventuality can bind NPs in argument positions which lack these predicates. These functional predicates are not overtly lexicalized in the VP domain, but they can be reflected on the nonspecific participants that they bind.

This all suits the data presented in (150), and repeated here as (154). Observe that, as predicted, even the reading in which there is an unspecified quantity (iterative) of the eventuality of John eating e.g. many sandwiches is available for (154c). This reading corresponds to the derivation in which the nonspecific participant is generated as quantified, *many sandwiches*, and the eventuality is a bare VP (bare plural). This reading is different from the one in which the participant is bound by the QP (there are many instances of the eventuality of John eating sandwiches) or by both the QP and the VP (there are many instances of the eventuality of John eating a single nonspecific sandwich). This reading is also different from the one in which there is a singular eventuality of eating many sandwiches. In this reading, and in general where the canonical singular of the eventuality involves a quantified nonspecific participant, the singular over the eventuality has no overt reflex and counts as the default interpretation.

- (154) a. John ate sandwiches for ten minutes/in ten minutes.
 b. John ate the sandwich in ten minutes/for ten years.
 c. John ate three/many/less than five/some sandwiches in ten minutes/for ten years.
 d. John ran the race for ten years/in ten minutes.
 e. John ate a sandwich in ten minutes/for ten years. (*a sandwich* being nonspecific)

Now I return to the most problematic question that the model is facing, which is how NPs with mass interpretation, which are therefore non-quantified, can escape being bound by the predicates of the VP and the QP? While the fact that quantified

nonspecific NPs are not bound is explained by their being already quantified, there is no such explanation available for NPs with mass interpretation.

3.6. Mass participants in non-mass eventualities?

Let me first briefly summarize the consequences of the views exposed so far in this section. I presented a model of eventualities as involving counterparts of grammatical number and quantifiers that ‘live on’ the nominal category. The counterpart of the grammatical number is the telic template, and both domains involves the same quantificational predicates, in projections that differently labeled only for technical reasons, to distinguish between their appearance in the nominal (#P) and the verbal domain (QP). Parallel to nominal expressions, eventualities can be mass (atelic, bare states and processes), bare plural (telic iterative, a bare telic template) or quantified (telic quantified, a telic template with a QP). If one or more of the participants of the eventuality is nonspecific and unspecified for quantification, and if the eventuality is quantified, the quantifier over the eventuality binds this participant, and it is overtly phonologically reflected in the NP expressing the participant. Similarly, if the participant is unspecified for grammatical number (i.e. if it is originally generated as a mass noun), and if it appears in a telic template, it is bound by the VP for grammatical number and surfaces as a bare plural. If a nonspecific participant independently generates one or both of the properties discussed (grammatical number and quantification), its full meaning undergoes the relevant binding, leading to what is known as a collective reading. For a bare VP that involves, e.g., a quantified nonspecific Goal, this results in an iterative reading where the canonical singular of the eventuality involves a Goal with the specified quantity. In cases like this, when none of the arguments is base-generated as non-specific and mass, there is no reflex of the predicates from the domain of eventualities on the participants. Therefore, unless this predicate is lexically marked (like telicity can be marked by verb particles or Goal phrases), or it is a default interpretation (like singular is), it will not be preserved in the interpretation of the sentence.

One serious problem for this approach is, as briefly mentioned in the preceding subsection, that eventualities involving a telic decomposition can still appear with nonspecific arguments lexicalized as mass nouns. The present model excludes this case, since any NP that is generated without a predicate of division and quantification is automatically bound by the corresponding predicates in the eventuality in which it appears. Every telic eventuality has a divided denotation, derived at the level of the VP, and therefore binds every non-divided NP in its domain. This means that no NP argument of a telic eventuality should surface as a mass noun. However, this is empirically incorrect, as illustrated in (155).

(155) John ate sugar for ten minutes/?in ten minutes.

Furthermore, this eventuality appears to combine with the *for*-phrase, but not with the *in*-phrase, which means that it is homogeneous. This points to an easy solution for the problem: the lack of a singular reading can be interpreted as a sign that the eventuality is in fact not telic at all, but rather represents a process of eating. Processes are atelic, they belong to the broad class of states, simple eventualities, and therefore receive a mass interpretation. If that is the case, there is nothing to bind the mass NP and it can surface as a mass.

This is further supported by the fact that the verbs that tend to only appear in expressions that represent telic eventualities, such as *to kill* or *to break*, cannot really combine with mass nouns in argument positions. This is shown in (156), where under an episodic reading, the sentences are ungrammatical (habitual readings have a special structure that I avoid discussing in this dissertation).

- (156) a. #/?John killed cattle.
b. #/?John broke ice.

Whether these sentences are grammatically or pragmatically odd, depends on one's view on the lexicon. For a radically non-lexicalist view such as Borer (2005a, b), this is a case of pragmatic unacceptability, while for the approaches that allow for structure in the lexicon, the sentences are grammatically ill-formed.

3.7. Mass Undergoers in Serbo-Croatian

However, I now present some data from Serbo-Croatian, where mass nouns appear in clearly telic eventualities, seeming at first sight to contradict the predictions of the present model. The discussion will show that in fact, not all these NPs are mass nouns, and that those that are mass are all generated in partitive phrases, which isolate them from the predicates of the VP level that have the potential to bind them.

Let us observe a type of eventualities that has at least one mass participant. In most Slavic languages, mass direct objects do not surface (only) in the accusative case, like other direct objects, but (also) in genitive. Partitive meanings are typical for the Slavic genitive case, and the intuition is that exactly partitive meanings figure in the examples where the direct object is in the genitive, as in (157a, c).

- (157) a. Jovan je (po-)pio vod-e. Serbo-Croat
Jovan AUX over-drank water.GEN
'Jovan drank water.' 'Jovan drank up some water.'
- b. Jovan je (u-)sipao vod-e u bure.
Jovan AUX in-poured water.GEN into barrel
'Jovan poured water into the barrel.' 'Jovan poured in some water into the barrel.'
- c. Jovan je (po-)jeo jabuk-a.
Jovan AUX over-eaten apples.GEN
'Jovan ate apples' 'Jovan ate up some apples'
- d. Jovan je (na-)bacao jabuk-a u korpu.
Jovan AUX on-thrown apples.GEN into basket
'Jovan threw apples into the basket.' 'Jovan threw in some apples into the basket.'

At least one type of Slavic verb prefix always results in the eventuality denoted by the VP being telic and, as some linguists (such as Žaucer 2002 and Gehrke 2005a, b) convincingly claim, they appear to represent stative predicates of the result subevent. These are the so-called internal prefixes, given in brackets in (157). They are included here to demonstrate that the telic structure in Slavic languages can take this kind of genitive. English translations for the examples are always given in the following order: the first one corresponds to the sentence with a non-prefixed verb and the second to the sentence with the prefix.

This type of verb prefix in Slavic languages normally triggers a specific interpretation for the Undergoer of the eventuality. Data of this type are for instance used in Krifka (1998) and Borer (2005b) to illustrate the relation between the eventuality and its participants. However, when the NP realizing the affected participant bears genitive, no specificity is enforced and the NP is ambiguous between a specific and a nonspecific interpretation. Observe the paradigm illustrated in (158).

- (158) a. Jovan je po-pio vod-e. S-C
 Jovan AUX over-drank water.GEN
 ‘Jovan drank up some water.’
 b. Jovan je po-pio vod-u.
 Jovan AUX over-drank water.ACC
 ‘Jovan drank up the water.’
 c. Jovan je po-pio malo/čašu vod-e.
 Jovan AUX over-drank little/glass.ACC water.GEN
 ‘Jovan drank up a little/glass of water.’

In the sentence in (158a), where the affected participant *voda* (water) bears a genitive, the interpretation of this participant is ambiguous between a specific and a nonspecific reading. For the specific interpretation, it is important that only some specific part of the specific water and not the entire specific water is undergoing the process. For the nonspecific interpretation, it is always some nonspecific water that has been drunk, and only the amount of the water drunk is interpreted as specific.

In (158b), the corresponding participant is in the accusative, and this forces a specific reading. The nonspecific reading is not available. In this case, the entire specific amount of water has to be undergoing the process and not only a part of it.

In (158c), with both an accusative and a genitive form, the accusative element is interpreted as specifying a part of the denotation of the genitive NP. Many different amounts or glasses of water that can satisfy the given predicate may be pragmatically available. This, nonspecific, interpretation for the accusative phrase is strongly preferred. Again, their nonspecificity does not mean that they can be mass: in both cases, only a bounded quantity interpretation is available. For such readings, the denotations of the accusative elements in these two examples become specific only once the eventuality, which provides them with a definite description, has been introduced to the discourse, i.e. only after a sentence like in (158c) is uttered.

Observe now that in (158b), just as in (158c), pragmatics allows for many different candidates that can satisfy the predicate of the accusative NP. Unlike in (158c), this is not sufficient to allow for a nonspecific reading. It appears that the presence of a (nonspecific) phrase in genitive with a partitive interpretation licenses the nonspecific reading of the affected participant lexicalized by an accusative NP. It is sufficient for the purposes of our argument to conclude that the Undergoer position in eventualities morphologically marked for telicity is not reserved only for specific nominal expressions, but that indeed it can only receive a bounded, i.e. non-homogeneous, interpretation.

This indicates that the default structure of the VP with a mass NP in an argument position, at least in Slavic languages, is the one in which the mass NP is in the partitive complement of the actual argument NP. For the example in which the representation of the Undergoer involves a mass noun, this means that the actual

which the Undergoer appears are filled with the NP_i, which is structurally represented in the lower half of the figure in (159d). The structure of this NP has three relevant sequences, the one in which the core material of the NP_i is represented, then the Partitive Phrase (PartP) complement that it takes, and finally the NP_j that this PartP introduces. The interpretation is that the denotation of the higher NP is part of the denotation of the lower one. A detailed discussion of the partitive relation and its relation to specificity is available in Arsenijević (to appear, b).

The higher NP is the actual Undergoer and it is assigned accusative case. This NP is always non-mass, as predicted in the present model: it must be bound by the VP, as well as by the QP, if present. If the partitive phrase is not overtly represented, the accusative NP receives a specific reading.⁵⁰ If the partitive phrase is present, both options are available.

The NP in the PartP is assigned genitive case by the head of the PartP. The VP does not influence the interpretation of this NP, since it is too deeply embedded inside a NP without a canonical singular. Lack of any predicate with the potential to define the canonical singular (size, shape, type) in the higher NP intervenes for binding by a predicate that is sensitive to this property, i.e. by any predicate that introduces division and any quantificational predicate that requires division in order to apply. Another option is that the lower NP is simply too deeply structurally embedded and therefore out of the reach of binding.

It is possible that the core NP_i is empty of any lexical material and that the only part of the whole structure that has a phonological realization is the PartpP. In this case, the direct object will appear in the genitive, with a proper mass interpretation. However, the intuition is always that the actual Undergoer of the eventuality is not the whole denotation of this genitive NP, but only a nonspecific bounded part of it.

This last observation is in fact crucial for the question concerning the mass participants in the telic template: How is it possible that the telic structure of an eventuality derives a mass interpretation when one of the relevant participants is a mass NP? The answer suggested by the S-C paradigm is that this mass NP is not really the Undergoer but its partitive complement. This holds only if some level of universality is assumed between different languages in the domain of grammar, allowing us to generalize over the S-C paradigm.

The S-C paradigm shows that mass NPs cannot directly represent the Undergoer but can only appear in its partitive complement. If this is a universal property of the template, the mass NP that surfaces as a direct object in the English sentences may be generated in the partitive complement of the Undergoer. In those cases, the Undergoer itself is extremely light: it corresponds to a fully unrestricted variable, except for the property denoted by the PartP. This NP, which is basically a variable, can be bound by the VP and the QP, but its predicate does not provide the material required to define a canonical singular. It is only marked as a part of some mass, but not specified for any property that may determine a unit of counting. The canonical singular is therefore interpreted relatively loosely, it may vary with each instance of

⁵⁰ A possible explanation for this last part of the argument is that the partitive phrase can be omitted only if the partitive relation is strongly contextually determined. In this case, not only is the NP in the partitive phrase old in the discourse and therefore definite, but so is the partitive relation, and therefore the part itself, i.e. the NP realizing the Undergoer.

the eventuality, and it is not clearly determined for any particular sentence (unless strongly suggested by the context).

Let us again consider an English example with a singular eventuality that requires telic decomposition and a mass Undergoer, as in (160).

(160) John poured water into the barrel.

Applying the conclusions drawn from the Slavic paradigm, we observe the following. The entity involved in John's pouring activity and the entity ending up in the barrel have identical descriptions: they are both represented as variables without a direct restriction and are both parts of the mass of water denoted by the mass NP. This has the following consequences.

The two NPs appearing in the positions of the Undergoer are coreferential, since they are variables with the same restriction and the same (binding) context. Their coreference forces the interpretation of concatenation, which further derives the meanings of initiating, result and change. However, the actual Undergoer, represented as a very light NP, appears to be too light to provide a determined canonical singular. The entire structure of the NP apart from its PartP complement (see (159e)) is empty. While it is still possible to divide an unspecified part of a mass, just like it is possible to divide a mass, it is not possible to count the units resulting from this division, because there is no predicate to determine the unit of counting. An NP of this kind cannot be subject to count quantification. This means that NPs that only carry semantic contents in their PartPs can appear in VPs, since they can be divided, but not in QPs, because they cannot be counted. eventualities with such NPs in argument positions never have a proper singular or any other directly quantified interpretation (unless additionally specified by the context). These eventualities always remain at the level of a bare plural with a fully unspecified unit of division.

Under this analysis, the eventuality in the sentence in (160) is a bare plural, with an unspecified, possibly varying, unit of division. The sentence therefore denotes that at some point in past there was an eventuality that involved an unspecified number of instances of John pouring unspecified quantities of water into the barrel. This is only slightly different in S-C, where inner aspect is marked overtly (though possibly indirectly) on the verb through morphology.

There are several levels at which the lack of specification gives interesting results. First of all, it is not excluded that the number of instances of pouring could accidentally be one; simply, this cannot be seen as resulting from the strict entailment of any of the readings. The intuition that such a reading might be available comes from the fact that the default reading has a singular (as opposed to bare plural) reference time.

The fact that the NP under discussion does not define the canonical singular at the level of the eventuality in which it appears has one more interesting aspect. For the bare plural (iterative) interpretation of the eventuality, each of the instances of the iteration can involve a different quantity of water. Since no grid can be determined for the division in this NP, nothing guarantees that the units resulting from the bare plural are all identical.

The most important consequence in this respect is that the lack of a specified unit of counting for one of its participants causes the eventuality to fail to specify its own

unit of counting. Therefore, such an eventuality cannot take any quantification, it never projects a QP, which means such an eventuality is never non-homogeneous, an effect confirmed by the tests. This analysis preserves the generalization that mass nouns cannot surface as direct arguments of telic eventualities.

The general mechanism described here applies to all nonspecific NPs. Therefore, we still can keep the generalization that a mass NP can be generated in an argument position of the telic template, but it cannot surface as a mass NP since it would then be bound at least by the VP. Those NPs that at first sight appear to contradict this prediction are in fact embedded within a PartP, and isolated from being bound by the VP and the QP. This holds for all arguments of the telic template and not only for Undergoers. We can therefore formulate the following generalization, which follows directly from the present model.

(161) Every mass NP generated in the direct argument position of a (telic!) VP, including Initiators, Undergoers, Sources, Goals and Paths, is bound by the divided VP and inflected for plural. Every mass NP surfacing in one of these positions must be generated in some more deeply embedded position, such as for instance a PartP.

This means that I expect mass NPs not to appear as direct Undergoers, but also not as direct Sources, Goals, Paths or Initiators. This prediction is clearly confirmed for proper Goals, Sources and Paths. Witness in this respect the clear unacceptability of the sentences in (162).

- (162) a. *John pushed the cart to water.
 b. *John pushed the cart from hay to sand.
 c. *John pushed the cart along road.
 d. *Water killed John.

Some other elements appearing in result phrases might look at first sight as if they contradict this generalization. Observe for instance the example in (163a). Looking more closely, however, we see that the Undergoer in this sentence (wine) must be interpreted partitively. Consequently, the result must be interpreted either partitively as well or as a predicate.

- (163) a. John turned wine into water.
 b. John turned the wine into (the) water.
 c. The wizard turned the colour of the chair into blue.

The non-partitive interpretation in which the entire quantity of wine of the world is turned into the entire quantity of water of the world appears to be unavailable; speakers confirm that this meaning requires definite NPs. This is due to the fact that all the wine and all the water of the world must be presupposed and thus old in the discourse. Also, they are by definition maximized: there is no wine and no water in the world apart from that denoted by these NPs.

Finally, there is the question of the lack of overt realization of the partitive component for the mass NPs. I have shown, however, that they are overtly realized in languages in which the partitive is morphologically marked by case, for instance S-C. On the other hand, the partitive preposition *of* and its counterparts generally tend to elide with mass complements, as shown in (164).

- (164) a. John drank some (*of) water.
 b. Jan heeft wat (*van) water gedronken. Dutch

The general possibility of leaving the partitive meaning without overt realization is further supported by the bare nature of the NP. As argued in Arsenijević (to appear, b), in a large number of contexts, mass nouns and bare plurals are interpreted with partitive meanings, without an overt marking of the partitive relation.

This subsection offered a solid explanation for why mass nominals can appear in telic VPs, without being bound and turned into bare plurals. It further explained the difference observed in the beginning of subsection 3.5, namely that eventualities with bare plural Undergoers have very prominent iterative interpretations while those with mass Undergoers do not have them, or if they do – then these readings are difficult to get.

3.8. Consequences for bare plurals

If the analysis from the last subsection holds, the question that arises is what are the consequences of this account of mass arguments for arguments surfacing as bare plurals? Bare plurals also often license a covert partitive marker, and just like mass nouns, they are nonspecific and homogeneous, and have similar effects on inner aspect. Let us therefore consider a telic eventuality with an Undergoer which surfaces as a bare plural NP, as in (165).

- (165) John pushed carts to the shop.

There are three structures predicted by the present model that can derive this sentence. One is that the Undergoer (*carts*) is generated as a mass NP, and then bound by the VP, which is how it becomes a bare plural. The second is that it is generated as a bare plural independently of the telic template of the eventuality. This structure corresponds to the collective reading of the quantified nonspecific arguments familiar from section 3.5. The third option is that the bare plural NP is in fact generated in the partitive complement of the relevant argument, and the NP of the argument itself has no other contents. This structure is parallel to the one assigned to the VP arguments which surface as mass NPs in the preceding subsection.

Let me first point out that two of these three structures certainly do not involve a QP. This holds for the first and the second case, and it is clear from the fact that the QP, if present, would bind the nonspecific argument, which would therefore not surface as a bare plural.

In the third case, the situation is a bit more complicated. This eventuality cannot project a QP, for the same reason as with partitive mass NPs: no canonical singular is defined for the Undergoer, which is nonspecific, and therefore no constant canonical singular, required by a count quantifier, can be defined for the telic eventuality. The eventuality is thus a bare VP, which means it should be ambiguous between the singular and the bare plural reading. This is indeed the case: the sentence in (165) either denotes a single instance of the eventuality of pushing some quantity of carts (a part of their aggregate quantity in the context) to the shop, or an unbounded number of iterations of this eventuality.

Let us consider each of the three types of structure that theoretically can derive a bare plural in the position of the Undergoer more thoroughly. The first structure has

already been discussed in this chapter, and I will review it only briefly. Here, the bare plural form reflects the VP of the eventuality and the canonical singular of the eventuality involves the canonical singular of all its nonspecific participants. This structure gives the most natural and most prominent reading.

- (166) ‘Normal’ reading: a mass NP bound by the VP⁵¹
 ‘John pushed carts to the shop.’

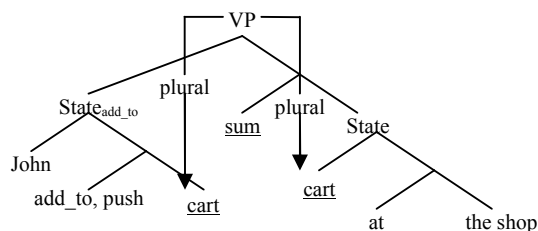

As mentioned above, with the given structure this sentence does not involve a QP because the QP would bind all the bare plurals in its domain and turn them into quantified expressions. Since this obviously does not happen with the Undergoer, the QP must be absent. This is confirmed by tests for inner aspect, which all attest to the homogeneity of this eventuality.

The second theoretically possible structure involves an Undergoer that is base-generated as bare plural, and thus its grammatical number is independent and not a consequence of binding by a higher predicate. I refer to these interpretations as collective readings. In such readings, there is an unspecified divided quantity of the telic eventuality of pushing, and the canonical singular of this eventuality involves an unspecified divided quantity of carts. This structure, provided in (167), does not derive a well-formed semantic interpretation.

- (167) Bare plural generated independently of the eventuality: an ill-formed template
 ‘John pushed carts to the shop.’

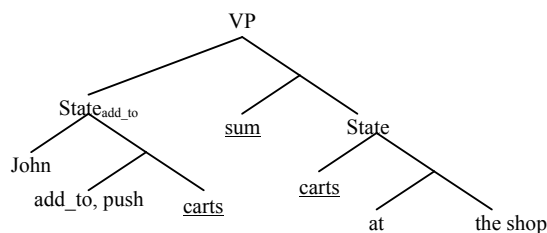

The ill-formedness results from the fact that the canonical singular of the eventuality is not a proper countable unit, due to the mass division interpretation of one of its arguments. While having a quantified argument still allows for defining a canonical singular, due to the fact that a countable argument can be collectively interpreted as a single unit in quantification, having a bare plural does not. A bare plural that is

⁵¹ The Goal position is marked here as empty. However, in section 0, I argue that it is filled either with a VP (in which case the Undergoer position also takes a VP) or with the NP that appears as the Undergoer. For now, this can be ignored.

homogeneity and non-homogeneity, which are traditionally associated with inner aspect, to the presence of a QP in the structure, i.e. to the presence of a quantifier in the aggregate predicate of the eventuality. The presence of quantification is directly dependent on the properties of the lower structure, in particular on whether it defines a canonical singular and involves mass division. This aspect of the meaning of the eventuality is directly derived from decomposition.

The parallel with Borer's model of the nominal domain is established as follows. The level of the VP, based on the concatenation between two states, is parallel to Borer's CIP. Both phrases project over a structure that has a mass interpretation and both impose a mass division on it. Furthermore, the QP projected immediately over the VP parallels Borer's #P. These phrases introduce quantifying predicates, restricting the meaning of the expression to a bounded subset.⁵²

I argued that specificity, as a deictic property, presents a barrier for interactions between the predicates of eventualities and the predicates of the nominal expressions representing their arguments. Nonspecific NPs, which all lack certain functional predicates, can be bound by the corresponding predicates from the structure of the eventuality, in particular by the predicates of division (the VP) and quantification (the QP). This causes them to surface as bare plurals or quantified NPs, respectively.

This structure predicts that no mass participant can be derived as a direct argument of the states building the VP. If a mass NP was generated in a telic eventuality, the telic structure would have it bound and inflected for grammatical number. I argued that this is indeed empirically confirmed by the data from Serbo-Croatian in which mass interpretations are available only for NPs generated as partitive complements of the actual direct arguments. I further argued that this holds universally, and that every NP that surfaces in a mass interpretation in a telic eventuality in fact receives a partitive interpretation.

Eventualities denoting a change in which it is not possible to form the canonical singular of one of their participants (most importantly of the Undergoer) fail to combine with quantificational predicates. This happens for instance when this position only contains the embedded partitive construction. In such cases, the telic template is defective in this respect and it can not be subject to proper count quantification.⁵³

A major aspect of the presented view is that the mereological properties of eventualities, and therefore also inner aspect, are associated only with quantification over the eventuality. An eventuality is non-homogeneous if it is quantified and homogeneous if it is not. Correlations between the mereological properties of eventualities and those of their participants appear only with nonspecific bound participants. They result from binding that is established between the quantification over the eventuality and the nonspecific participants. If nonspecific participants are bound, the mereological properties of the participants will reflect the mereological properties of the eventuality. While in the traditional approaches to the English VP,

⁵² In fact this is not true of mass quantifiers, which quantify directly over mass, but this is orthogonal to the discussion.

⁵³ I do not explicitly discuss quantification that directly takes mass meanings, since such quantifiers are less frequent in the domain of eventualities and they are not directly relevant for the topic of the dissertation.

the properties of the participants are transferred to the eventuality; in the present model transfer occurs the other way around.

This section also led to one simplification of the model: the predicate *concat*, for concatenation, is replaced by the lighter predicate *sum*. The meaning of concatenation is shown to be derived from the meaning of *sum* and the properties of the Undergoer (coreference of the two positions in it is generated and the properties it is assigned).

4. Possible points of criticism

4.1. A note on the reflexes of the QP on nonspecific participants

In the model presented so far, the phenomenon whereby the quantifier of the VP level is reflected on one or more of the nonspecific arguments of the VP is of particular importance. This concerns examples such as (170), with the reading in which there were seven instances of the eventuality of pushing the particular cart to some shop or other.

(170) John pushed the cart to seven shops.

The model that I introduced assigns to the relevant reading of (170) an analysis in which the numeral *seven* in *seven shops* is a reflex of the covert numeral *seven* that quantifies over the telic eventuality of pushing the cart to a shop. This presents a radical turn in dealing with the correlations between the quantificational properties of an eventuality and the properties of its arguments. In this subsection, I present further empirical support for this aspect of the analysis.

One potential point of criticism of the model might be the claim that the phenomenon I capture is simply an instance of the more general, and well known, phenomenon of distributive readings of quantified expressions. Although this observation holds, it cannot be viewed as real criticism, since no explanatory and constrained analysis of either of the two phenomena has to my knowledge been offered so far. Therefore, the analysis I propose can be viewed as an attempt to formally capture at least some instances of distributivity, i.e. those in which the eventuality appears to distribute over its arguments. Moreover, the same pattern of predicate-binding might also be applicable to other types of distributive readings.

More substantial critiques are those that target the analysis itself, especially targeting the lexicalization of the quantifier over the eventuality in the NP realizing one of the arguments. I therefore want to offer further and more detailed support for the contents of the present model.

Observe that for sentences of the type in (170), if more than one nonspecific argument is present in the VP, these arguments can all take the same quantifier, and still derive the meaning in which there are seven instances of the eventuality of pushing a nonspecific cart to a nonspecific shop. This is shown in (171) for the reading in which there were seven instances of pushing one cart to one shop.⁵⁴

(171) John pushed seven carts to seven shops.

⁵⁴ The reading in which there are seven eventualities of pushing a single cart to a seven shops is ignored as it is derived from the other possible structure where the numeral in *seven shops* is independently generated on the NP.

This is exactly what the proposed analysis predicts.

Of course, the other option, of still having the quantifier on only one argument, and leaving the other argument in a singular indefinite form, is also available, as shown in (172).

(172) John pushed seven carts to a shop.

Although it requires some forcing, this sentence can also have the meaning in which each of the cars is pushed to a different shop, i.e. where the shop varies with each instance of the eventuality. This does not contradict the proposed analysis, since in this case an additional relation, between the nominal expressions, may take part in the aggregate interpretation. It is possible that the participant *a shop* is base-generated within the NP of the participant *cart*, as one of its defining properties, and that this is where the binding relation between the two is established. The same participant (*a shop*) also appears in the Goal participant position, where it gets the eventuality-related interpretation, and this is where it is lexicalized. This also derives the difference between the two almost equivalent interpretations, the one discussed for (172) and the one in (171). In (172), the NP headed by the noun *shop* has an interpretational component directly related to the interpretation of the NP headed by the noun *cart*.

Support for analyzing the quantifier on the nonspecific arguments of the eventuality as a reflex of the quantifier over the eventuality for all sentences of the type in (170), (171) and (172), also comes from a parallel between this and another well-known and documented phenomenon. There are striking similarities between reflecting the quantifier over the eventuality on one or more of its arguments and reflecting the negation over an eventuality (or a higher projection) on one or more of its arguments, the phenomenon usually referred to as negative concord.

Full negative concord, which is exhibited in many languages, including some from the Slavic family, is illustrated in (173), where the negation over the full eventuality or even a higher level is reflected on each of the nonspecific arguments of the eventuality, through what is usually called an N-word (marked with an *N* in the example).

(173) Jovan ne gura nijedna kolica ni-u-jednu radnju. S-C
 Jovan not pushes N-one cart N-in-one shop
 ‘Jovan doesn’t push any cart to any shop.’

Whatever the precise technical analysis of how the N-words emerge in the instances of the negative concord is, the generalization is preserved that they are related to the presence of the negation in some higher, c-commanding, position. Labels such as ‘distributive readings’, at least in their standard use, are not particularly appropriate in this case for a number of reasons. First of all, the negation and the N-words are all overtly present, while in distributive relations the quantifier appears only on one member of the relation. Having each element independently marked for a certain predicate is exactly the opposite of the standard distributive effect, and closer in this respect to some kind of coreference or co-indexation (all the N-elements correspond to only one negation). Second, in most traditional approaches, negation specifies a certain set as being empty, and it is difficult to talk about distribution over an empty

set. Intuitively, it would be more appropriate to speak about binding, or simply quantifying into the domain, which is more in the spirit of the present model.

Observe also that, similarly to the situation discussed above about the relation between (171) and (172), the N-word may as well be omitted on one or more nonspecific arguments, if they are in some other way bound by one of the arguments that are lexicalized with the N-word. The sentence in (174) has one reading which is parallel to the interesting interpretation of (172), i.e. where the shop is nonspecific and ‘distributively’ interpreted with respect to the carts.

- (174) Jovan ne gura nijedna kolica u radnju. S-C
 Jovan not pushes N-one cart in shop
 ‘Jovan doesn’t push any cart to a shop.’

The purpose of drawing this parallel is to show that what we are dealing with is a more general phenomenon in language. Its core consists in the lexicalization of a certain reflex of some predicate on the elements to which it applies by virtue of containing them in its c-command domain. These elements, naturally, may not involve a corresponding predicate in the structure. What is shown here is that this effect is not restricted to numerals and quantifiers only, but can also appear with negation and a number of other predicates (see Zeijlstra 2004 on how N-words and related forms can appear in the context of questions or modal predicates). The difference between VP or QP binding and negative concord can be reduced to the lexical availability of elements that can lexicalize the original instance of the quantifying predicate. While in most languages, there is a morpheme that lexicalizes the higher level negation, relatively few languages contain elements that lexicalize quantifying and division predicates over eventualities. Therefore, there is usually no lexicalization of such predicates in the position in which they are generated, but a lexicalization of their reflexes may appear on the elements over which they quantify.

Finally, although it is not a very common property, some languages contain elements that can easily be analyzed as a lexicalization of the quantifier over the eventuality. I now present a set of data in which the quantifier over the eventuality arguably receives an overt realization. The data come from Mandarin Chinese, and are mostly borrowed from Zhang (2002), but also involve examples collected from a number of speakers that I additionally consulted.

Apart from nominal classifiers, Mandarin also exhibits so-called verbal classifiers, or event classifiers. Classifiers can roughly be defined as elements that individuate, i.e. that define the canonical singular of a meaning, which can further be quantified in a way that requires countability. Verbal classifiers, however, not only allow for eventualities to be overtly quantified, they also make it possible to overtly mark a certain argument as bound by the quantifier of the eventuality.

I provide a general example involving verbal quantifiers in (175).

- (175) Akiu qu-nian bing-le liang {chang/ci/*tang}. Mandarin
 Akiu last-year sick-PERF two CL/CL/CL
 ‘Akiu fell sick two times last year.’ (Zhang 2002: 2)

The numeral *liang* (two) quantifies over the eventuality of getting ill by quantifying over the verbal classifier (*chang* or *ci*). While *ci* is a general verbal classifier which

can be used for any eventuality, *chang* is a more specific one (i.e. with a stronger classifying force), and appears with a restricted set of meanings. Precisely because of the specificity of the classifier meaning, another classifier, *tang*, cannot combine with the eventuality of getting ill (while it does combine for instance with the eventuality of travelling to some destinations and back).

Apart from these classifiers, which are to a large extent functional elements with no transparent lexical meaning, there are other verbal classifiers with more transparent lexical semantics. Such is the case with the classifiers in (176).

- (176) a. Ta da-le Baoyu liang bazhang. Mandarin
 he hit-PRF Baoyu two CL_{palm}
 ‘He hit Baoyu twice with his hand.’ (not necessarily with two hands)
- b. Ta da-le wo liang zuiba.
 he hit-PRF I two CL_{mouth}
 ‘He slapped my mouth twice.’ (Zhang 2002: 4)

The same eventuality in (176) takes two different classifiers, *bazhang* (palm) and *zuiba* (mouth). I have been informed by a considerable number of speakers that although this does not exhaust the full number of semantically transparent classifiers that can appear in this position, the possibilities are limited to the few that introduce a particular pragmatically relevant type of hitting (i.e. define a natural class).

This is very much in line with the predictions of the present model. The two classifiers are linked to the meanings of the Instrument (*bazhang*, palm) and the Undergoer (*zuiba*, mouth, here actually referring to the cheek), both being participants of the initiating subevent (the latter is in fact also a participant of the result subevent, but that is not relevant for the present discussion). The structure therefore contains an element linked to one of the participants from the initiating subevent and represents the canonical singular of the entire eventuality. More formally, a part of the material from the specifier of the VP is used to represent the canonical singular of the VP. This element does not fully specify this canonical singular: the canonical singular derives its full meaning from the entire predicate of the eventuality. Recall that in the present model, the VP is the counterpart of the Classifier Phrase. The specifier of the VP, i.e. the initiating subevent, is the counterpart of the position in which the nominal classifier is generated. The parallel is therefore complete: some material from the specifier of the phrase realizing division is taken to represent the unit of division. From this perspective, it is the addition of the initiating subevent and the head of the VP over the already projected structure of a state that makes the structure specify a canonical singular, just as it is the addition of the classifier in the specifier and the division predicate in the head of CIP over a lexical noun that derives a divided mass interpretation. It appears to be very natural for the unit that represents the canonical singular to come from the initiating subevent.

It would be surprising to find that a property or a participant that is involved only in the result subevent, such as the result predicate or (a property of) the Goal, is used as the verbal classifier. This appears indeed to be impossible, according to more than a dozen Chinese speakers. Speakers, both linguists and non-linguists, were offered examples such as (177), and encouraged to formulate other examples obeying the

same pattern with possibly better candidates for classifiers, but no grammatical sentences could be formed.

- (177) a. he travelled to London five tasks/meetings/appointments/hotels
 b. he kicked ball (across field) two goals
 c. he went to cinema two seats

This is exactly as expected: the classifier cannot be generated in/from the complement of the VP. The complement is a structure that is simply selected by the VP to occupy its complement position, and does not contain any functional elements characteristic of the head of the VP. It is also more deeply embedded and therefore farther away from the higher functional predicates. The specifier of the VP, on the other hand, is added to a structure that already has a specified head, and may therefore display some sensitivity to its contents. This is reflected in the requirement that the element that appears as the classifier in Chinese must, even if lexical, still display countability, just as with the VP, where the simple eventuality in the specifier must be dynamic (i.e. it must involve the predicate *add to*).

In (176), the verbal classifier has meanings that seem to correspond to the Instrument, i.e. the directly affected part of the Undergoer. However, the speakers' intuition is that this does not really refer to the relevant participant of the eventuality. Its most direct interpretation is that of introducing a unit of measure for the entire eventuality. It requires of course that the kind of hitting is of the type done by hand and on the mouth, respectively, but this is perceived rather as a modification than as the introduction of a new participant. In fact, many speakers require that in (176a), where the classifier to some extent corresponds with the instrument, the slapping be on the face (the cheek or the ear in fact). A more transparent translation of both sentences in (176) might thus be something like 'He gave Baoyu two hand-slaps on the face.'

The meaning of the verbal classifier therefore corresponds to the meaning of a nonspecific NP, quite symptomatically so, bearing in mind that in the present model, nonspecific NPs reflect quantification over the eventuality. In fact, nonspecific NP arguments arguably all display some degree of semantic incorporation into the meaning of the predicate. This goes well with the claim that these NPs are also bound by some of the predicates in the VP, the QP, or higher functional projections.

I therefore suggest that verbal classifiers are generated as nonspecific arguments of the initiating subevent, and are then semantically incorporated into the meaning of the predicate. This makes them good candidates for appearing as classifiers: they specify the natural class of the eventuality (in the given example hitting 'with a hand' and/or 'on the mouth'), and they are directly involved in the predicate of the eventuality (unlike specific arguments which establish reference independently of the eventuality).⁵⁵

Finally, in Mandarin Chinese, verbal classifiers can participate in a particular construction with nominal classifiers, which Zhang refers to as the *compound classifier*. As illustrated in (178), compound classifiers mark that the canonical singular of the

⁵⁵ The NP *the mouth* is not really definite in this case, its definiteness comes from the fact that it is embedded through a part-whole predicate under another participant (the Undergoer) and unique in this domain.

argument related to the nominal classifier component is involved in a single instance of the eventuality related to the verbal component in the compound classifier.

- (178) Zhe tiao lu shang-zhou tongguo-le qiche san-bai
 this CL road last-week pass-PRF car three-hundred
 liang-ci. Mandarin
 CLN-CLV
 'On this road, three hundred instances of car-passing occurred last week, each
 time one car.' (Zhang 2002: 13)

This is equivalent to saying that compound classifiers mark that the quantifier over the eventuality (which is linked to the compound classifier) also quantifies over the nonspecific participant related to the nominal component of the compound classifier. This is an overt realization of the relation between the quantifier over the eventuality and the nonspecific argument.

In conclusion, the data from Mandarin Chinese, in which quantification is lexicalized in a direct relation with classifiers, support the following two aspects of the present model. First, they confirm that eventualities can have a full range of quantification generated in their own predicate. Second, they display a more transparent morpho-syntactic marking of the link between the quantification over the eventuality and the quantification over its nonspecific participants.

In Chapter V, I present additional examples of the overt lexicalization of material from the heads of the VP and the QP, using examples from S-C, where the quantifier over the eventuality and the head of the VP are arguably morphologically realized.

4.2. Singular and bare plural as the default interpretations

So far I have treated eventualities without any reflex of their quantifying predicates as fully ambiguous between an iterative and a singular reading. The prominence of a bare plural reading (i.e. the unbounded iterative reading) for a telic eventuality can be explained quite directly through the lack of any overt quantification on the eventuality in combination with the semantic component of mass division resulting from the telic template. The prominence of the singular reading is less natural, unless related to pragmatic factors, which is not the most attractive solution.

Observe once more the sentence in (179).

- (179) John pushed the cart to the shop.

Its most prominent readings are the one where there was one instance of John pushing the cart to the shop (the singular reading) and the one where there was an unbounded number of instances of this eventuality (the iterative reading).

In this subsection, I sketch one possible way of accounting for these facts formally. I introduce an additional component, the reference time, and use it especially to account for sentences which involve no nonspecific singular NPs, but still receive a singular reading. I do not offer a full account of reference time and outer aspect, but only sketch one possible direction for further thought.

At the level of outer aspect, the temporal interval of an eventuality is ordered with respect to a reference time (see Demirdache and Urribe-Etxebarria 1998 for a detailed account). It can be marked to precede, follow, or contain the reference time

by the predicates *after*, *before* and *in*. The most straightforward way to represent this structurally is shown in (180).

(180) Structural representation of outer aspect

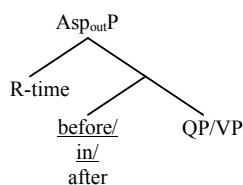

The reference time is usually old in the discourse, its quantificational properties are provided by the context, and as can be clearly seen in (180), it c-commands the entire structure of the eventuality. Therefore, in the default case, the eventuality will be assigned all the predicates which it lacks from the reference time level. This means that in fact, an eventuality normally receives the quantificational properties of the reference time, unless its own quantification is overtly marked (as a quantifier over the verbal classifier, reflected on a nonspecific participant or as a quantifier on a nonspecific argument NP).

This explains the prominence of the singular: in most cases, the discourse specifies a singular reference time. This is due to the fact that cases in which one particular temporal interval is relevant for the discourse are most frequent, although other contexts may also appear. Since the introduction of the reference time also introduces an additional complexity that is beyond the domain of this dissertation, I will not go further in this discussion. Instead, I will only address several points that may seem problematic for the present model.

If distribution over the reference time is an option, and if it uses the same mechanism of predicate-binding, then one also expects to see its effects with other structures than the singular, such as for instance quantified eventualities or bare VPs. This would lead to having the eventuality universally represented as a variable that is bound by the reference time. It would be restricted by its own predicate, but it would still pick a referent for each instance of the reference time.

With two additional remarks, this is indeed the generalization that is empirically confirmed. The two additional remarks are the following. First, it has been assumed so far, and it is also further argued for in sections 3 and 4, that only QPs can project predicates that relate to the reference time. This means that a bare VP will never be in situation to be bound by the reference time. Second, the inner aspect is indicated at the level of the QP. Whatever the status of the eventuality after being related with the reference time, it only matters for inner aspect whether it has a QP or not.

The generalization that only QPs can be related with the reference time is expected for several additional reasons. In terms of the cognitive quasi-physics that underlie temporal and spatial structures in language, it is quite impossible to order a homogeneous eventuality, which has an unbounded temporal interval, with respect to some other interval, which is firmly positioned on the temporal line. Moreover, and this is relevant for a narrower set of cases, it is impossible for the reference time to quantificationally bind an eventuality that does not define the canonical singular. This means that eventualities that do not define a canonical singular, such as states,

processes and the VPs that involve partitive NPs (see 3.6 and 3.8) cannot appear with outer aspect.

As mentioned above, some support for this view is provided in the discussion of progressive and perfect forms of stative verbs in section 3. Furthermore, in Slavic languages, where perfective aspect is morphologically marked, such marking on the verb is only possible for telic eventualities. The line of thinking outlined here is, however, only a sketch, and the problem remains an interesting and important topic for further research.

4.3. Summary

To support the general mechanism proposed in section 3 for the relation between the properties of the eventuality and those of its participants, I drew a parallel between the reflexes of quantification over the eventuality appearing on its arguments and other similar relations in language, such as for instance the negative concord phenomenon. In addition, I discussed some Chinese data, in which the quantification over the eventuality is directly lexicalized, and in which the relation between the quantification over the eventuality and that of one of its participants is overtly marked.

At the end, I briefly discussed the question of the readings available for telic eventualities without any overt marking of their quantification. I suggested that quantification can also come from the level of the reference time. This explained the empirical regularities in the observed domain. At the same time, it raised the question of whether eventualities without a defined canonical singular can combine with outer aspect, and I suggested that this was not the case.

One important property of the present model is that the decomposition of an eventuality is given a formal status. Although decomposition has a clear role in the conceptual interpretation of eventualities, especially for the initiate-result relation, it is, crucially, also related to countability and quantification of eventualities.

5. Concluding and evaluating remarks

In this chapter, I presented a new model that represents eventualities at the interface between semantics and syntax. The model establishes a strict parallel between the NP as accounted for in Borer (2005a) and the projections of the VP. States can be used to build a semantically richer structure when they appear as arguments of the predicate *sum*. If it happens that in such a structure, one state is dynamic, corresponding to a process, and the other is stative, and in addition that the same participant appears to have a property affected in the dynamic state and to bear a certain value for the same property in the state, the interpretation of change is derived. The interpretation of concatenation is the only available one for the predicate *sum*, and the relation of initiation and result is established between the two states. I call this structural pattern the telic template. This is the only way to derive a telic eventuality, and telicity comes from the concatenation, in which stative state defines the termination of the eventuality. The dynamic state is interpreted as initiating the termination. For the telic template I used the label VP.

I further argued that the telic template derives a unit of division for the predicate of the eventuality and that it corresponds in this way to grammatical number, or the

classifier, in the nominal domain. The unit of division of a telic eventuality is the instantiation of the single concatenation that defines it.

Finally, an eventuality can be quantified. The quantifier of an eventuality is generated in the projection that appears immediately above the VP, labelled QP. The quantifier over a VP normally has no lexical realization and it can only be reflected as a nominal quantifier over one of the arguments of the eventuality. This happens if the argument in question is originally generated as a non-quantified nonspecific NP. Lacking its own quantification, it can be bound by the quantifier over the eventuality, and as a reflex of this binding, it lexicalizes a corresponding nominal quantifier. This mechanism of lexicalization is presented as similar to concord phenomena, in particular to the negative concord in which the negation of an eventuality or some higher predicate appears overtly on the nonspecific arguments of the eventuality. In certain languages, like Chinese, the quantification over the eventuality is overtly lexicalized, which further supports the account.

The advantages of this model are as follows. It reconciles the decompositional and the syntactic approaches to eventualities. The phrase that most directly represents the decomposition of the eventuality also has very direct effects on the quantificational structure of the predicate that is derived. It is therefore at once a representation of the semantic decomposition of inner aspect and a well-defined functional projection that corresponds to grammatical number in nominal expressions.

The model explicitly treats some phenomena that are usually simply stipulated as variable binding and distribution. Variable binding is analyzed into a relation between a predicate and a structure that it c-commands and is applicable to. Separate from pragmatic considerations of applicability, a predicate is applicable to a structure if this structure does not have a predicate of the same kind. At least some instances of distributive readings appear as a consequence of this type of binding in the domain of quantification.

This also reduces some effects of nonspecificity to binding effects: an expression has a nonspecific denotation if it lacks certain predicates in its structure, and can therefore be bound by the structure in which it is embedded.

Finally, the model, as presented here, does not go deep into syntax. Moreover, in one point, it opens a problem that seems difficult to handle in the domain of syntax. It concerns multiple instances of the same material in the structure, how they are generated and mutually related, and how they are taken care at PF, with respect to linearization and deletion. The difficult part is that some of these instances, in particular the two instances of the Undergoer in the telic template, do not stand in the c-command relation, a necessary condition for most relations that can license coreference between these two instances (such as binding or movement). However, there are ways to overcome this problem, for instance by placing the instance of the Undergoer in the initiating subevent in the specifier instead of the complement position (followed by an adequate modification of the interpretive properties of these two positions). Syntactic issues of this kind are left for future work.⁵⁶

⁵⁶ I thank Rajesh Bhat for bringing this problem to my attention as a member of the promotion committee.

Chapter IV: Eventualities as arguments with temporal reference

1. Introduction

Chapter III proposed a novel model of event structure at the syntax-semantics interface, establishing a connection between the semantic and the syntactic properties of VP and between the decompositional and the quantificational (or mereological) views of inner aspect. In this chapter I discuss the model with respect to two prominent dimensions of event structure: the status of eventualities in relation to time and the representation of eventualities as arguments.

The chapter gives a more elaborate picture of the proposed model and in particular defining the notion of a state, as the building block in the domain of eventualities. At the same time, it provides an analysis for the more complex meanings in the domain, such as the progressive, the perfect and the causative.

In section 2, I discuss some phenomena related to the temporal structure of the eventuality. I examine the semantics and structural representation of the *for-* and *in-*phrases which are used as tests for inner aspect. The discussion leads to certain corrections in the proposed model, in particular in establishing a more precise definition of states and processes. This definition implies that states and processes have temporal intervals and that eventualities are therefore conceived of as temporal structures. Section 3 is concerned with the relation between argumenthood and the categorial asymmetry between NPs and VPs. I argue that eventualities can sometimes appear as arguments, in particular in some forms in the domain of aspect and argument structure, such as progressives, perfect forms and causatives. I propose one structural representation for these three forms and show how, in the case of the progressive, it offers a nice solution to the so-called imperfective paradox. Section 6 provides additional empirical support for the proposed model. In this section, I apply the model to the complex aspectual system of Slavic languages. Apart from showing how the proposed model accounts for the Slavic paradigm, I also revise some views on the so-called Slavic semelfactive suffix *-nu*, and introduce some new data which involve an imperfective variant of this suffix. Section 4 concludes.

2. Matters of time

2.1. Introduction

In Chapters II and III, inner aspect is predominantly tested using temporal adverbials. In this section, I inspect in further detail how these tests work and what we can learn from them about the nature of an eventuality.

Temporal adverbial tests are based on the ways the temporal interval of the eventuality can be modified. Therefore, examining the nature of these tests means examining the relation between eventualities and time. The central question in this domain concerns the level at which eventualities receive temporal intervals. The discussion leads to the conclusion that this happens at the level of states, and that it is the temporal nature which in fact makes a predicate into a state. I link the temporal nature of states to the predicate *add_to*, for which I present a more general and formal definition than the one I have been operating with so far.

2.2. The nature of the *for*-phrase

The most standard test for inner aspect, and the one that has by default been used in this dissertation, is the temporal adverbial modification test. Two different prepositional phrases, used for temporal modification, the *for*-phrase and the *in*-phrase, appear to combine with two different types of predicates derived for the eventuality. The *for*-phrase only modifies homogeneous predicates and the *in*-phrase only non-homogeneous ones. These phrases therefore diagnose the mereological nature of the meaning they combine with.

The two phrases modify the predicate of an eventuality by modifying its temporal interval. In order to really understand the way the test works, we need to first develop a reliable model of how temporal intervals are assigned to eventualities.

In this subsection, I discuss the *for*-phrase. Two different strategies in accounting for the *for*-phrase are found in the literature. One of them, referred to as the *quantificational approach* (to my knowledge first proposed in Dowty 1979), analyzes the *for*-phrase as quantification over the interval that it introduces, with respect to a certain predicate. The analysis, roughly, assumes that the *for*-phrase has two effects: it introduces an interval and marks the modified predicate as holding for every relevant part of this interval.

For the sentence in (181), this means that within every part of a certain interval of ten hours, it holds that John walks.

(181) John walked for ten hours.

A problem for this approach, already noted in Dowty (1979), is that the *for*-phrase can also introduce non-consecutive intervals the sum of which provides the length specified in the *for*-phrase. This is illustrated in (182), where the most pragmatically salient interpretation is that there are many different intervals during which John brushed his teeth, or was reading something, and all that is required is that their sums amount to three days and two months, respectively.

(182) During the last ten years, John brushed his teeth for three days and read for two months.

Efforts to capture this, and some other properties of the *for*-phrase, led to another analysis, which is usually referred to as the *measure function analysis*. This analysis is presented in Krifka (1989). The intuition behind it is that the *for*-phrase is similar to expressions that assign some measure to an otherwise unstructured meaning (just like phrases of the type *seven grams/meters/liters of NP*). The measure in the *for*-phrase is temporal, and it is specified by the nominal complement of the preposition *for*, which denotes a certain amount of time expressed in units such as seconds, minutes, hours, days, weeks, months etc.

Semantic aspects of the temporal measure phrase are discussed in Krifka (1998), where the term *extensive measure function* is used. Extensive measure functions map empirical relations to numerical relations, and therefore make it possible to assign certain units with numerical values to an empirically attestable quality. Krifka gives the example of temperature where the relation between different degrees to which something can be cold is mapped to the relation between numbers. Each individual quality can be assigned many different measure functions, but once a

measure function is determined, it is fixed for all its applications. Standard measure functions for temperature are degree Celsius and degree Fahrenheit, although nothing prevents us from defining infinitely many new measure functions for the same property.

The *for*-phrase for Krifka is a phrase that assigns an extensive measure function for time to a certain predicate. In his theory, predicates of eventualities all undergo another function (the *temporal trace function*), which assigns them the property of having a temporal interval. The extensive measure function for time then assigns a certain degree, measured in the numerical value of a certain unit, to the temporal interval of the eventuality. This means that for Krifka every predicate that can be assigned to an event argument must by definition have a temporal trace. The *for*-phrase only specifies the length of this interval by mapping it onto a value.

There is one further possible analysis of the *for*-phrase worth considering. It is a slightly more complex, but also more general, version of Krifka's analysis, which is motivated by the observation that extensive measure functions are usually specified by quantified NPs, while the *for*-phrase is a PP.

I first observe other cases of realizing a measure in a PP with the preposition *for*, and then relate it to the discussion of the *for*-phrase. Observe the examples in (183), where the measure phrase for the apples introduced by a NP yields a fully acceptable sentence, while the one involving a PP with the preposition *for* is strongly degraded.

- (183) a. Give me seven kilograms of those apples.
 b. ??Give me (those) apples for seven kilograms.

In fact, there is a measure that is normally introduced by a PP headed by the preposition *for*. As illustrated in (184), it is used when a measure that is imposed does not directly measure over the object to which it is imposed, but rather relates to it indirectly, through some context-determined proportion.

- (184) a. #Give me seven dollars of apples.
 b. Give me apples for seven dollars.

In (184b), the quantity of apples is bounded and measured by the quantity of dollars. The matching determined by the proportion in the presented case involves two measures, one of which is more natural for the measured object. This more natural measure is the weight or number of apples that corresponds to seven dollars through some proportion established by the price of a kilogram of apples or of a single apple. The reason why a direct partitive phrase as in (184b) is not an option for this type of meaning is probably that the amount of money that a quantity of apples is worth is not perceived as an immanent, inalienable property of apples.⁵⁷ Thus, it can only measure apples through another measure, related to a more natural property of apples, in this case weight or number. The price can thus determine the quantity of apples only by matching with this other property.

⁵⁷ V. van Gelderen (p.c.) drew my attention to the fact that even in English there is a way to use a (pseudo)partitive construction to relate the price and the quantity of a matter, but then the use of an additional noun is required, as in *seven dollars worth of apples*. This fact actually confirms my analysis: only once the inalienable property that is measured is overtly introduced (here *worth*), a (pseudo)partitive construction can be used.

Finally, the construction in (183b) is not ungrammatical in all languages. Look at the S-C examples in (185), which realizes exactly this pattern.

- (185) Daj mi jabuk-e/jabuk-a za sedam kila. S-C
 give me apples-ACC/-GEN for seven kilograms
 ‘Give me seven kilograms of apples’, or rather:
 ‘Give me a quantity of apples to match/make seven kilograms.’

This example has a different meaning than a proper partitive construction (I henceforth refer to the modification involving the partitive construction as the *partitive modification*), which is also available in S-C. One difference is that in (185), there is an intuition that what is asked for will be first estimated (thus in a way measured as well) based on some other units than kilograms, possibly pieces or even some informal, subjective unit of weight, used to estimate the quantity that will make seven kilograms. The person to whom the sentence is directed should estimate some weight or number of apples, or some other measure, so that measured on a scale in kilograms, they will weigh seven kilograms. In other words, some other unit, which is possibly a different unit of weight, is assumed to be present before the weight in kilograms is determined. Crucially, the measure introduced in the PP is separated from the object that it applies to and, is therefore always deprived of any extension.

For a finer tuning of the intuition behind this construction observe the sentences in (186).

- (186) a. U sobi je jabuka za sedam kila. S-C
 in room is apples.GEN for seven kilograms
 ‘There are seven kilograms of apples in the room’
 lit. ‘There are apples for seven kilograms in the room.’
 b. U sobi je sedam kila jabuka.
 in room is seven kilograms apples.GEN
 ‘There are seven kilograms of apples in the room’

A further difference between the interpretations of these two sentences is that the one in (186a) can hardly be used if the apples in the room are on one pile, or in one bag, i.e. if they form a compact whole. At the very least, it implies that the apples consist of a number of smaller quantities which have to be summed to match the measure that is introduced. This further implies that the apples are distributed in more than one place within the room. The sentence with the partitive modification in (186b) favors the other reading, with only one pile, box or bag with seven kilograms of apples. This difference is even stronger if a mass noun is used. This is in fact expected, since apples suggest division even without any further modification because their lexical meaning (shape) is closely associated with having a canonical singular.

This again points towards the conclusion that the measure phrase with the preposition *for* tends to involve a more complicated relation between the measure that it introduces and the measured object than the one involved in partitive modification. Even when the matching takes place between two instances of the same property, it is required that the one on the measured object first be summed up and then matched.

Example (186) suggests that it is possible for the measure expressed in the PP and the contextually provided matching measure to apply to the same property (in this case weight). I do not tackle here the interesting question of why this case is excluded in English.

The point of this excursion into the non-temporal meaning of the measure involved in the preposition *for* is that the rough analysis of this construction presented here can be extended to the *for*-phrases used to test inner aspect. The *for*-phrase in this view matches between the temporal measure that it introduces and some other contextually suggested measure of the eventuality that it modifies. This contextually suggested measure can be temporal, but it can also relate to other properties, including, as an interesting case, singular instances of a telic eventuality, as in the plural readings of eventualities of the type in (187).

(187) John pushed carts to the shop for ten hours.

The entailment of the iterative reading of this sentence, according to the suggested analysis of the *for*-phrase, is that all the instances of John pushing a single cart to the shop that occurred, if summed up, match in their temporal interval with the interval of ten hours. I therefore refer to the English *for*-phrase type of modification as the *matching modification*.

There is, however, an important asymmetry between the temporal measure and other measures. While I noted above that the PPs with *for* used in the nominal domain cannot have any extension, this is not the case with the temporal interval introduced by the *for*-phrase. The difference is obvious, as illustrated in (188).

(188) a. John has apples for ten dollars.
b. John ran for ten minutes.

In (188a), the fact that apples are existentially quantified has no effect on the measure: ten dollars are still lacking extension. On the other hand, in (188b), the binding of the eventuality by tense extends to the temporal interval in the *for*-phrase: if the eventuality has taken place, the interval in the *for*-phrase also has an extension.

If the eventuality is embedded under a modal meaning, and the *for*-phrase does not scope over this modal predicate, both the eventuality and the temporal interval are intensionally embedded, as in (189).

(189) John wished he could run for ten days.

This difference in fact follows from the following two facts.

First of all, as I additionally argue in the remainder of this section, time is an immanent, inalienable property of eventualities, while properties measured by PPs that modify nominal expressions are often not.

Secondly, and more importantly, the predicate within the domain of eventualities that is in charge of reference, and therefore also able to provide the extension, is either outer aspect (as in e.g. Demirdache & Uribe Etxebarria 1998, and also in the present model) or tense (as in Borer 2005b). In both cases, it is a temporal predicate, which orders two temporal intervals. It is therefore natural, especially for the present model of eventualities, that this temporal predicate should also bind the temporal measure in the *for*-phrase.

On the other hand, the corresponding predicate in the nominal domain consists of specificity and/or definiteness. There is no measure that typically applies to either of these two properties in the way temporal measure applies to the property that makes eventualities specific: their temporal interval. Ergo, there is also no good candidate for the measure introduced by a PP with *for*, to be bound by the predicates of specificity and definiteness.

The discussion above only applies directly to languages with an adverbial modification of the English type, i.e. where the temporal adverbial that measures homogeneous eventualities uses (the counterpart of) the preposition *for*. Not all languages, however, have the same structure for the temporal modifier of homogeneous predicates. There are languages that use a different type of temporal adverbial to measure homogeneous eventualities. Such is the case for instance in Dutch, illustrated in (190), where the element used seems to correspond to the predicative measure phrase.

- (190) Jan heeft zeven minuten (lang) gelopen. Dutch
 Jan has seven minutes (long) walk.PTC
 ‘Jan walked for seven minutes.’

Observe in this respect the examples in (191), where the same construction is used as a predicate and as a modifier adjoined to the NP.

- (191) a. De film is anderhalf uur lang. Dutch
 the film is one_and_a_half hour long
 ‘The film takes one hour and a half.’
 b. de anderhalf uur lang-e film
 the one_and_a_half hour long-DEF film
 ‘the film that takes an hour an a half’

It appears therefore that Dutch, just as S-C and many other languages, uses a different type of modifier for this kind of modification. I refer to it as the *measure-property modification*.

To make the picture more complicated, in some languages the counterpart of the English *for*-phrase is used with non-homogeneous eventualities. This is the case in S-C, as is shown in (192).

- (192) a. U sobi je jabuka za sedam kila. S-C
 in room is apples.GEN for seven kilograms
 ‘There are seven kilograms of apples in the room’
 lit. ‘There are apples for seven kilograms in the room.’
 b. Jovan je po-pio litar vode za dva minuta.
 Jovan AUX over-drink.PTC litter water.GEN for two minutes
 ‘Jovan drank a litter of water in two minutes.’

It appears that in S-C, the *za*-phrase, which is the literal counterpart of the *for*-phrase, matches a singular instance of the telic eventuality with the temporal interval that it introduces. I leave the precise analysis of this relation for future work.

In any case, the discussion of the *for*-phrase in this subsection is intended to provide a tentative analysis, rather than to establish a firm ground for the discussion

of the temporal aspects of event structure. I do not crucially rely upon it in my further discussion of temporal adverbials. It has shown, however, that what Krifka sees as the extensive measure function and Dowty as quantification, does not exhaust the full interpretation of *for*-phrases and their cross-linguistic counterparts. What is particularly interesting is the contribution of the preposition or other material used to introduce the measure. The discussion here also led us to one important observation, namely that the measures contained in the temporal adverbials can have an extension, while this is not the case for the measures specified in partitive (183a) and predicative (191a) constructions.

2.3. *For*-phrase and the temporal structure of the eventuality

The discussion in the preceding subsection suggested that every eventuality that can be measured by a *for*-phrase is assigned some measurable property already before being modified. Since the *for*-phrase applies to stative eventualities and processes, already states, as the building blocks from which any eventuality is built, might have a measurable property. The most natural candidate for the measurable property of a state seems to be its temporal interval. If it is indeed the case that states are assigned temporal intervals, it would mean that all eventualities, no matter their level of complexity, are characterized by temporal nature. In which case, temporal intervals are not to be viewed as separate semantic components that are assigned to an eventuality, but as an immanent part of the predicate. One of the consequences is that quantificational predicates in the domain of eventualities always apply to a predicate that involves a temporal interval.

This excludes two possibilities. One is that eventualities are assigned temporal intervals somewhere higher, for instance immediately over the VP, over the QP, or even higher up in the structure, in which case they are assigned to a predicate that already has a (partly) derived quantificational structure. The other excluded possibility is that temporal modifiers, one of which is the *for*-phrase, in fact assign temporal intervals to non-temporal predicates. The same holds for the corresponding phrases in other languages, like the ‘x temporal_unit (*long*)’ phrase in Dutch and in S-C. Although they might attach to different levels in the structure, they still modify predicates which are already assigned temporal intervals. I now present some data that illustrate more directly the temporal nature of both states and the telic template.

Let us observe the sentences in (193).

- (193) a. John closed the shop for two weeks.
 b. John went to Vancouver for a couple days.

The *for*-phrase in these two sentences properly combines with singular (i.e. non-iterative) telic eventualities. This type of reading is in fact, for both sentences, the more prominent one (the other involving an iterative eventuality). In this reading, the adverbial is not modifying the entire telic eventuality, but only its result subevent: the states of being closed and being in Vancouver, respectively. Obviously, it is possible to modify the temporal interval of the result subevent.

At the level at which it is modified, in the model presented so far, the subevent is a bare state, without any division or quantification, and it therefore receives a mass interpretation. This means that if the subevent has a temporal interval, this interval is

unbounded. On the other hand, any temporal modifier that assigns a measure can assign it only to a bounded property. This means either that there is something else that bounds the temporal interval of the result state in these examples, or that the temporal adverbial in fact not only measures the temporal interval, but assigns boundaries to it as well.

Let us look at the consequences of this fact for the template of a telic eventuality, repeated here as (194).

(194) Template of a telic eventuality

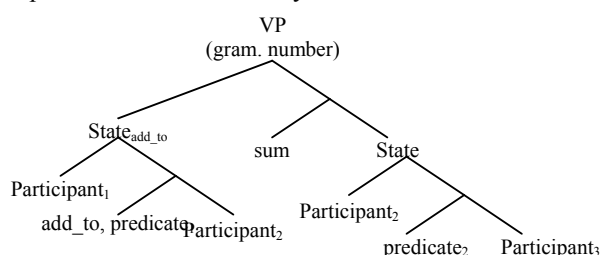

In the present model, the VP introduces division, forming a counterpart to the nominal bare plural in the domain of eventualities, as a consequence of concatenating two states with a mass interpretation. Delimiting the result state eliminates one of the main elements in the definition: one of the two concatenated elements becomes bounded and therefore no longer a state. We therefore expect some effects to distinguish this structure from a typical telic eventuality.

Such effects do indeed appear. The most prominent one is that in telic eventualities with temporal modification of the result subevent, the initiating subevent cannot have a rich lexical predicate, i.e. the verb cannot incorporate much manner-related modification. As the examples in (195) show, any heavier lexical meaning on the verb results in a grammatically degraded structure (speaking only about the singular, non-iterative reading, since the iterative reading takes the *for*-phrase in a higher position and not over the result subevent).

- (195) a. John closed/??slammed the door for five minutes.
 b. John went/??ran to London for five days.

The predicate of the initiating subevent can only have a very light meaning, essentially the meaning of the predicate *add_to*, which in this case corresponds to bare causation. It might also involve the property under change and its result value (the incorporated result predicate). A similar property, but in a higher degree, can be observed in causative structures as in (196).⁵⁸

- (196) a. John made/??sang Mary close the door.
 b. John made/??laughed Mary go to London.

⁵⁸ Berit Gehrke (p.c.) reports that the degraded examples in (195) appear to be less bad than those in (196) and suggests that the parallel is not full. I think however that the difference comes from other differences between these constructions, while the observed parallel still holds quite strongly.

This is not surprising. Causatives are traditionally viewed as telic eventualities that have a fully fledged eventuality in their result subevent position (a paraphrase of the definition from Levin & Rappaport Hovav 1999). In terms of the present model, a predicate corresponds to a fully fledged eventuality if at least one functional projection is introduced, i.e. minimally a proper VP, or even a QP. If the result subevent in a causative construction is a fully fledged eventuality, it certainly does not receive a mass interpretation. This is parallel to the effect of the *for*-phrase.

It appears that depriving the result subevent of its mass interpretation in a concatenated structure, whether by using a *for*-phrase or by projecting a functional structure, leads to the same type of effect. The initiating subevent is reduced to the meaning of causation and the properties of the entire structure change because what is concatenated is not mass, but bounded predicates.

The structure of an eventuality in which the temporal interval of the result subevent is assigned a measure is presented in (197): the *for*-phrase adjoins to some projection of the state before becoming an argument of the concatenation. At this point, I remain agnostic with respect to the nature of the projection(s) the *for*-phrase adjoins to.

(197) Modification of the result subevent by a *for*-phrase

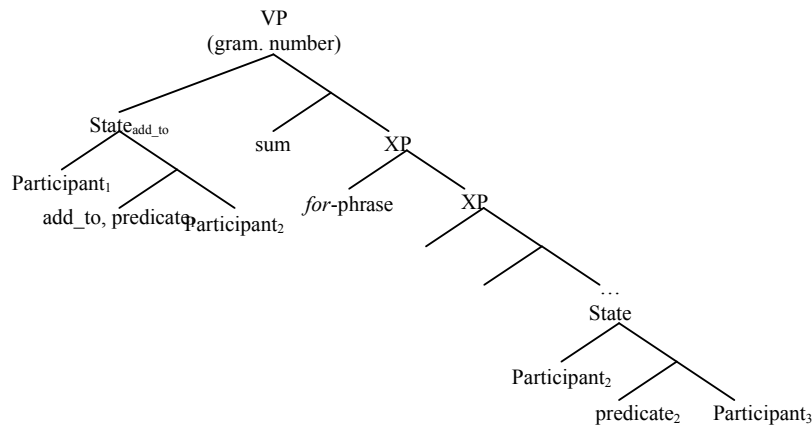

If the result state can be assigned a temporal interval and this interval can be modified, a natural question is whether the same holds for the initiating state.

There is, indeed, a construction in English in which the *for*-phrase seems to be modifying the initiating subevent. This construction is illustrated in the English sentences in (198).

- (198) a. ?John ran for ten minutes to the store.
 b. ?John swam for three hours to the island.
 c. ?John heated the water for ten minutes to 90 degrees.
 d. ?John carried the message for five days to the headquarters.
 e. ?John cut the cheese for twenty minutes to 35 pieces.
 f. ?John shelved the books for three hours onto the top shelf.

Most native speakers find these sentences slightly degraded (some of them are often judged as fully grammatical). For most sentences, however, the only possible interpretation involves the result of the eventuality not being reached yet. In other words, not the entire telic structure is entailed to be bound by the higher projections such as tense or modal predicates.

The structure is parallel to the one in (197), and it is given in (199).

(199) Modification of the initiating subevent by a *for*-phrase

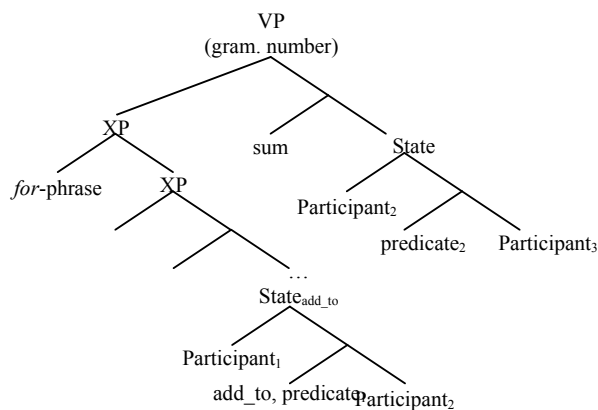

In the interpretation of tensed non-modal sentences of this type, only one part of the aggregate meaning derived in the concatenated structure is truly entailed to be bound by the tense or other higher projections.⁵⁹ The entailment of the clause always covers the initiating subevent and leaves the entire result subevent intensionally embedded. In (198a) for instance, John's running is described as ending at the store, but that component of the meaning of the clause is not entailed. It is only entailed that John participated as the agent in some running, but not that it was such that he ended up at the store. This could be described by saying that only a part of the initiating subevent in the eventuality is entailed. It makes these eventualities very similar to progressives. Progressives are traditionally defined as having a meaning that entails only a part of the initiating subevent from the aggregate description of the eventuality (see e.g. Bennett & Partee 1972). Compare the sentences in (198) with those in (200). They are identical in denoting that the result state was not reached, i.e. that only a part of the initiating subevent took place.

- (200) a. John was running to the store.
 b. John was swimming to the island.
 c. John was heating the water to 90 degrees.
 d. John was carrying the message to the headquarters.

⁵⁹ The discussion of the progressive in the next section will lead to a more complex structure than the one in (199). The additional element will be that instead of the result state, there will be the full VP, and the head of the full structure will be the predicate of intersection, and not sum. In the current discussion, however, the given representation serves its purpose.

- e. John was cutting the cheese to 35 pieces.
 f. John was shelving the books onto the top shelf.

This parallel with the progressive might be the precise reason why the sentences in (198) are degraded: their meanings are normally expressed using the progressive. In addition, there are prepositions denoting direction rather than goal, such as *towards*, which derive similar meanings, as in (201).

- (201) a. John ran towards the store.
 b. John carried the message towards the headquarters.

Therefore, the examples in (198) may be degraded due to the elsewhere effect. The meaning resulting from a temporal modification of the initiating subevent tends to be realized in two other ways. These two ways, the progressive and the directional prepositions, are more universal because they do not require the presence of a temporal adverbial (the *for*-phrase) to realize the relevant meanings.

There is one further possible reason why the sentences in (198) are degraded, namely that there is a clash between the *for*-phrase and the result subevent, since one of the (indirect) effects of both is marking the initiating subevent as bounded. Probably due the fact that the *for*-phrase appears to be structurally closer to the initiating subevent, as well as the fact that it appears first in the linear, left-to right word order in the sentence, results in the *for*-phrase having priority. As a result, the result subevent cannot be properly interpreted, and the sentence is degraded.

However, with a modification of the result subevent (193), at least in the linear, phonological word order of the sentence, the telic template is identified before the *for*-phrase. The *for*-phrase is then applied to the result subevent, without any fatal consequences for the already formed interpretation of division.

Observe now the following examples from Dutch, which represent an attempt to produce the effect discussed in English.

- (202) a. ?/Jan heeft/is drie uur lang naar de winkel
 Jan AUX three hours long to the shop
 gelopen. Dutch
 walked
 b. ?Jan heeft/is naar de winkel drie uur lang gelopen.
 Jan AUX to the shop three hours long walked
 ‘John walked for three hours and reached the shop.’
 c. ?Jan heeft/is naar de winkel gelopen drie uur lang.
 Jan AUX to the shop walked three hours long
 ‘John walked for three hours, and reached the shop.’

Although none of these sentences are fully acceptable, they are also not strongly ungrammatical. Some speakers have a clear contrast between the one in (202a), which they judge quite bad, and those in (202b-c), which they find only slightly degraded. Furthermore, the sentence in (202c) appears to involve some correction, or a similar mechanism, since speakers tend to report that they parse the adverbial modifier (*drie uur lang*, ‘for three hours’) separately from the rest of the sentence.

Word order in these examples appears to play a role in two different ways. First of all, in the sentence in (202b), it reflects a particular structure. Secondly, in (202c), it

seems to enable a correction: the telic eventuality is fully interpreted and only then is it temporally modified, so some degree of correction helps in finding a meaning that is a part of the meaning of the telic eventuality and can be modified in the given way. The best candidate is the initiating subevent, which is already defined as leading to the result. It is therefore interpreted as both leading to the result (reaching the shop) and having an interval of the specified length (three hours).

Another point of variation is the use of the auxiliary. Some speakers find the sentences much worse when taking the auxiliary *zijn* (be), while others consider the examples equally good with both auxiliaries. The two auxiliaries, *hebben* (have) and *zijn* (be), are traditionally seen as selected based on the aspectual properties of the eventuality (e.g. Shannon 1988). Perfect forms of non-stative eventualities are built with *hebben* if the VP is atelic and with *zijn* if it is telic. The fact that for some speakers the examples in (202) have the same status with both auxiliaries is suggesting again that the telic template is not properly formed when only the initiating subevent is modified.

Finally, observe that as in the English examples, the fact that the eventuality is interpreted as telic and singular and therefore non-homogeneous, makes it impossible for the *for*-phrase to attach to a level higher than the VP. Moreover, the adverbial obviously does not modify the duration of the result subevent. The only remaining option, which also represents the speakers' intuition, is that the adverbial applies to the initiating subevent. The alternative, i.e. to have a mechanism that does not belong to the narrow grammar match the temporal interval with the full eventuality in spite of the way this interval is introduced, is rather unattractive.

The parallel established before the discussion of the Dutch examples, between eventualities with a temporally modified initiating subevent and the progressive, tells us something about the nature of the progressive. Just as the causative was generalized as the meaning derived by projecting a functional layer in one of the subevents, the meaning of the progressive could come from some special structural property of the initiating subevent.

I return to this problem in subsection 2.4 and in further detail in section 3.

The conclusion that we can reach concerning the temporal intervals of domains lower than the full eventuality, i.e. subevents, is as follows. It appears to be impossible to use the *for*-phrase to test whether bare subevents are assigned temporal intervals. Modification by a *for*-phrase affects the telic template and the subevents are no longer subevents of a real telic template. The state that is modified by the *for*-phrase by definition represents at the very least a VP, i.e. it is always a fully fledged eventuality and not a subevent. After modification, the structure is necessarily at least a QP, since it is obviously bounded, and therefore not a bare plural (VP) or a mass (a state).

In any case, modification by the *for*-phrase cannot diagnose whether a subevent in the telic template can be assigned a mass temporal interval. We are still forced to consider two options. One is that subevents are assigned mass temporal intervals, and the other that temporal intervals are only assigned to fully fledged eventualities, i.e. to VPs, QPs or higher, and that these temporal intervals take the quantificational structure of the predicate they are assigned to.

Finally, one property of the telic template was elaborated further. Prior to this section, the only possible candidates for concatenation into a VP were two mass

predicates. The discussion above has shown that it is in fact possible to concatenate divided and bounded predicates as well. Although this does not produce a canonical telic template with the interpretation of a mass division, it does nevertheless have the potential of projecting the clause, as any other VP. The telic template again appears to be a special case of a less restricted structure.

2.4. The position of the *for*-phrase

In the preceding subsection we reached the conclusion that the *for*-phrase may appear at different levels of the semantic and syntactic structure of clausal meaning. In the domain of the eventuality, it has been shown to modify the entire eventuality, but also the structures that it concatenates. Yet, the arguments of concatenation that are modified by a *for*-phrase are all in the end bounded and therefore correspond to QPs rather than to states. If we generalize this idea, it amounts to closely relating the presence of a *for*-phrase with QPs.

However, the fact that the phrase modified by a *for*-phrase eventually has the status of a QP does not necessarily mean that the *for*-phrase always selects for a QP. The interesting question is therefore the following: what are the selectional properties of the *for*-phrase in the domain of eventualities (leaving aside its possible appearance at the level of reference time or at a higher level)?

Possible candidates to be selected by the *for*-phrase in the present model are a bare state (a mass predicate), a VP (a ‘bare plural’ predicate) and a QP (a quantified predicate). Let us examine each of these three cases individually.

Can *for*-phrases combine with a stative eventuality? The straightforward answer is: of course they can, this is precisely what *for*-phrases are famous for. Bare states are homogeneous in the extreme and *for*-phrases notoriously combine with homogeneous predicates. Observe the examples in (203). Both sentences involve states without any iterativity and without any quantification, i.e. bare mass predicates, and the *for*-phrase combines with them perfectly.

- (203) a. John slept for an hour.
b. John was happy for ten days.

What about bare plural eventualities, i.e. bare VPs? The prediction is the same, bare plurals are homogeneous and the *for*-phrase should be able to modify them. Observe (204), where both sentences involve one bare plural nonspecific participant.

- (204) a. John ate sandwiches for ten days.
b. John pushed the cart to various shops for three hours.

The present model treats the plural in the non-collective reading of the bare plural participants (*sandwiches*, *different shops*) as a reflex of the bare plural on their respective eventualities. This means that each telic eventuality allows for a bare plural (i.e. unbounded iterative) reading, which is indeed the case in these two sentences. In fact, this is the most prominent reading in which the sentences are grammatical with the *for*-phrase.

Finally, can a *for*-phrase modify a QP? In the present model, QPs are by definition non-homogeneous. Since a *for*-phrase can only combine with homogeneous predicates, it cannot modify a QP. Observe, in this light, the examples in (205).

- (205) a. John ate three sandwiches for ten days.
 b. John pushed the cart to many shops for three hours.

The participants specified by quantified expressions (*three sandwiches* and *many shops*) in these two sentences are supposed to have one interpretation in which number reflects the quantity of iterations of the eventuality. In such a case, the eventualities respectively involve eating a single nonspecific sandwich and pushing the cart to a single nonspecific shop. In this type of reading, the eventuality is certainly a QP, and this reading is, as expected, unavailable in both cases.

There is another possible type of interpretation, in which the quantification is generated on the nonspecific participants, independently of the eventuality. In this case, the quantification over the eventuality is unspecified, and the interpretation is ambiguous between a bare plural and singular. One instance of the eventuality under this reading involves eating three sandwiches and pushing the cart to many shops, respectively. In this case, the *for*-phrase should be acceptable, yielding a grammatical structure. This type of reading involves an originally unbounded quantity of instances of eating three sandwiches and pushing the cart to many shops, which is then measured and bounded by the *for*-phrases, and it is indeed available for the sentences in (205), although due to pragmatic oddness, it requires some support from the context.

Finally, there is a third reading we may expect. This is the reading in which the *for*-phrase applies to the VP, and the QP quantifies over the entire structure. For (205b), this would mean that there was an eventuality of John pushing the cart for three hours and that this eventuality appeared many times. The structure leading to this interpretation is represented in (206): the *for*-phrase modifies the VP and the QP projects over this structure.

- (206) Reading in which the *for*-phrase is between the QP and the VP:
 'John pushed the cart to many shops for three hours.'

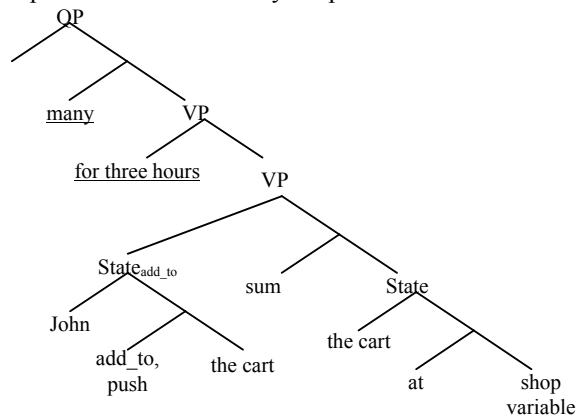

A reading similar to the one corresponding to this structure is in fact available. For the given sentence it can be paraphrased as: *for many shops it is the case that John iteratively pushed the cart to each of them for three hours.*

This reading, however, does not fully correspond to the structure in (206). The Major difference lies in the fact that the quantifier *many* in the reading that is available is generated not on the eventuality, but on the NP *many shops*. Moreover, it is generated very high in the structure, and certainly above the QP. This reading does not tell us anything about the position of the *for*-phrase, since it does not involve the structure that was supposed to be tested, namely the attachment of the *for*-phrase lower than the QP.

The exact structure in (206) derives a reading that can be paraphrased as: *many instances of an eventuality of iteratively pushing the cart to a group of collective-many shops*. This reading is not available, which suggests that the *for*-phrase cannot appear in a QP, not even lower than the quantificational predicate.

To summarize, the *for*-phrase can attach to both of the structures that are derived lower than the QP, but it cannot select for a QP with a quantificational predicate in its head, nor can it co-occur with it. In other words, the *for*-phrase and the QP have the same selectional properties (taking VPs or states) and they do not co-occur.⁶⁰ This indicates that these two elements target the same position. Recall now that in the preceding subsection, the *for*-phrase was shown to turn the structure it modifies into a QP. The *for*-phrase therefore behaves exactly as the QP in these two respects.

This leads to the conclusion that, when it modifies the eventuality, the *for*-phrase is generated within the projection that I label as QP. Since the QP is a phrasal element, the *for*-phrase is generated either as the specifier or as an adjunct to the QP. I will not go into the discussion of which of these two positions the *for*-phrase takes since it goes beyond the topic of this thesis. In any case, the structure of the example from (204b) is given in (207).

(207) Position of the *for*-phrase in the periphery of the QP

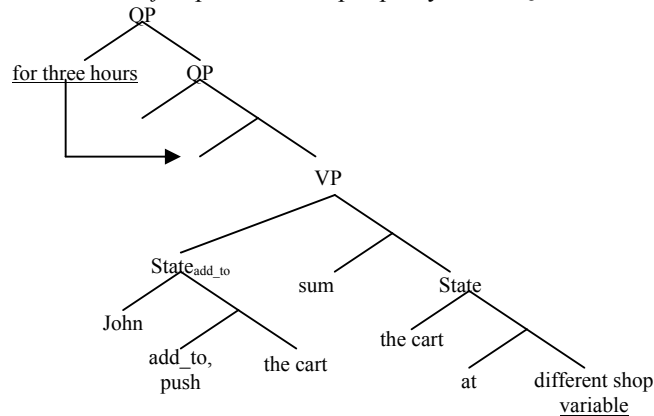

Either way, the *for*-phrase in fact assigns a certain quantificational predicate to the head of the QP. This predicate is relatively light, simply denoting 'a quantity', but it

⁶⁰ Although it is difficult to find an example where a proper quantifier appears in the QP and selects for a state, this should in principle be possible, since it is possible in the nominal domain for quantifiers like *much* and *little*. Observe however that these two quantifiers belong to the class of complex quantifiers, as defined in Chapter I, 3.4 and 3.5, which have been shown to display some special properties.

is sufficient to make the entire structure non-homogeneous. However, it is only possible to assign the predicate introduced by the *for*-phrase to the head of the QP if this head does not have any predicate that is independently derived there. This account is very similar to the one proposed in Borer (2005b), where the *for*-phrase assigns an aspectual feature, or more precisely a range to an open value, in the head of her aspectual projection.

The question arises here of how a temporal adverbial can assign a proper quantificational predicate to the head of the QP. With the English *for*-phrase, what happens is exactly what was predicted in the unified analysis for this PP presented in 2.2. The *for*-phrase matches the interval it introduces with the quantity of the eventuality through some context-determined proportion between temporal intervals and the particular eventuality. The predicate in the head of the QP is therefore assigned through this matching just as in *apples for five dollars*, where the quantity of apples is determined by the proportion between apples and money contextually given as the price.

If the described mechanism is universal, it is predicted that matching of a similar type is involved in the strategies used in other languages for this same task of temporal modification of homogeneous eventualities, even if they do not have phrases that overtly mark the matching-component. Alternatively, they might display behavior that is, in some respects, different from that of the English *for*-phrase. I leave this question for further research.

In any case, when combined with a phrase that is ambiguous between a homogeneous and a non-homogeneous reading, the *for*-phrase is only compatible with the homogeneous one, and eliminates the others. In other words, it combines only with readings where the predicates lack a quantifier component. This is what makes sentences as in (208) acceptable only under iterative readings.

- (208) a. John pushed the cart to the shop for three hours.
 b. John ate three apples (after lunch) for twelve days.

The singular reading for the eventuality in (208a) is derived by a covert singular predicate in the QP of the eventuality of pushing. Similarly, the reading in which there are three eventualities of eating a sandwich in (208) is derived with a covert numeral *three* in the head of the QP, which then binds the nonspecific argument *sandwich*. Both these structures are ungrammatical because it is only possible to generate a *for*-phrase in the QP if its head has no predicates of its own. The only compatible readings are those that have a bare plural (bare VP, unbounded iterations) interpretation before the modification. The aggregate meaning is that there were a number of iterations of the canonical singular of the respective eventuality (i.e. of one its iteration). Every quantified nonspecific participant in such readings must have its quantifier generated independently of the eventuality, which leads to a collective reading.

The meaning derived together with the *for*-phrase is non-homogeneous. This meaning belongs to the class of eventualities that Krifka (1998) treats as telic due to their bounded temporal interval. In the present approach, they are equivalent to any other non-homogeneous eventuality: they have a predicate in the QP. The only exceptional element is that the predicate in these cases is assigned by an adjunct to the QP. A mechanism similar to this one is used more generally in Borer (2005b).

Apart from the position in which it assigns a predicate to the QP, the *for*-phrase can also appear in other positions, where it modifies other aspects of the meaning of the clause. One of these was illustrated in Chapter II, subsection 3.4, where examples such as (209) were discussed.

(209) For an hour, nobody ate sandwiches.

In this example, the *for*-phrase may in theory scope higher or lower than the negation. When it scopes higher than the negation, the interpretation is that there was a period of an hour such that during the entire period there was no eventuality of someone eating a sandwich (here the *for*-phrase probably modifies the reference time). The other scope, which seems to be strongly degraded or altogether unacceptable, corresponds to the meaning in which there was no singular eventuality of eating a sandwich that lasted for one hour. The latter interpretation is expected to be strongly degraded, because it combines a *for*-phrase with a singular telic eventuality.

In (210), both readings for the two given types are fully available.

(210) For an hour, nobody ate sandwiches.

One reading is that there was an hour during which there was no instance of the bare plural eventuality of someone eating a sandwich. The bare plural on the Undergoer in this example (*sandwiches*) is a reflex of the bare plural on the eventuality. The other reading is that no singular eventuality of someone eating sandwiches had a one hour long temporal interval. To show that these readings indeed have different truth conditions, I present a situation in which one of them is false and the other is true.

The first reading is false if during some relevant period of an hour someone spent ten minutes eating sandwiches, and in these ten minutes he finished eating one sandwich and ate half of the second sandwich. Thus, an eventuality of eating a sandwich quantified by *one and a half* is such that it has taken place. Since the first reading introduced requires that no eventuality of eating (and finishing) a sandwich is such that its denotation has taken place, the sentence is false: an eventuality of eating a sandwich, quantified by *one and a half*, has taken place within the relevant interval.

The same situation makes the other reading of the sentence true. This reading requires that no eventuality of eating a sandwich lasted for one hour. In the situation described, an eventuality of eating a sandwich quantified by *one and a half* has taken place. However, this quantified eventuality has a temporal interval of only ten minutes, therefore smaller than one hour. The only eventuality that has taken place does not satisfy the second condition, imposed by the *for*-phrase with the low scope: its temporal interval is not one hour long. Therefore it is true that no eventuality with the given predicate lasted for one hour.

I assume that for the reading in which it scopes over the negation, the *for*-phrase appears at the level of the reference time. It gives the interval in which the epistemic evaluation of the eventuality of someone eating a single nonspecific sandwich gives a negative result. The reading in which it is in the scope of the negation is the one I have been discussing in this section, where the *for*-phrase is in the QP and assigns quantification to the eventuality.

It is also possible that the *for*-phrase, when combined with a stative eventuality, takes the higher scope and only relates the eventuality with the reference time. This

would be compatible with the expectation that a *for*-phrase should not be able to impose quantification on a non-divided mass.

To briefly summarize, the *for*-phrase, when modifying an eventuality, is related to the QP. It assigns a light predicate to the head of the QP and can therefore not combine with QPs that independently have other predicates in their heads. The test based on the *for*-phrase indicates whether the structure that it applies to has a non-homogeneous reading (i.e. a reading derived without any material in the head of the QP). There are also other possible positions in which the *for*-phrase can appear, for instance a position related to the reference time, but these do not provide indications of the quantificational properties of the eventuality.

2.5. The meaning and effects of the *in*-phrase

Contrary to the *for*-phrase, there is a strong consensus in the literature about the analysis of the *in*-phrase. The definition that Dowty (1979) gives for the meaning of the *in*-phrase can be paraphrased in the following way. The *in*-phrase, modifying an eventuality with the predicate P, will yield truth for some interval n if this interval has the exact length specified in the *in*-phrase and there is exactly one interval x such that it is a subinterval of n and the predicate P holds at x.

This means that (211) will be true for some interval n if this interval is two minutes long and if n has exactly one part at which it holds that John ate the sandwich. It is true both if the eventuality itself took an interval of one second and if it took the full two minutes, as long as no other eventuality with the same predicate appeared during the interval of two minutes.

(211) John ate the sandwich in two minutes.

Dowty's definition directly excludes homogeneous predicates, since they cannot hold at exactly one subinterval of any interval. Due to their homogeneity, they hold for every other, larger or smaller, subinterval as well (unless their temporal interval has a specified length, but this would make them non-homogeneous).

Krifka (1989, 1992) provides a similar definition, except that it is phrased in terms of extensive measure functions and temporal traces. The core of his definition is that there is an interval such that the *in*-phrase introduces its extensive measure function (i.e. specifies its length) and the interval of the eventuality is its part.

Krifka also argues that the apparent tendency for the interval introduced by the *in*-phrase to provide a measure of the interval of the eventuality, i.e. the fact that the interval of the eventuality is not a proper part of the one measured in the *in*-phrase, is an effect of Grace's Maxim of Quantity. The *in*-phrase is obviously an upward entailing adverbial, and the most informative measure that can be given by the *in*-phrase corresponds to its lower boundary.

In light of these definitions, I present a set of data that relate the *in*-phrase phrase to the telic template in a very interesting way.

The *in*-phrase appears to have two different uses. Observe the sentences in (212). Although they are both ambiguous, they show a preference for different readings.

(212) a. John ate the sandwich in three minutes.
 b. In three days, John ate the sandwich.

The preferred interpretation of the sentence in (212a) is that there was an eventuality of John eating a sandwich and it was finished within three minutes. The preferred reading in (212b) is that at or around the end of a period of three days after some other temporal interval, there was an eventuality of John eating a sandwich. This latter reading is similar to the meaning of the PP *after three days*. The difference is that in the latter case, the eventuality must take place after the end of the relevant period of three days, and not in one of its final parts.

I argue, however, that from a strictly formal point of view, the two meanings illustrated in (212) are identical. They differ in some pragmatic aspects, but their narrow semantics is the same. Most importantly, in neither case is it possible that the eventuality lasts for longer than the period introduced by the *in*-phrase. This is trivially true for (212a), but it appears also to be the case for (212b). If it took John more than three days to eat the sandwich, this sentence would not give a suitable description of any aspect of that eventuality.

The two different meanings of the *in*-phrase in both uses are therefore compatible with the general component in both Dowty (1979)'s and Krifka (1989)'s definition: the temporal interval of the entire eventuality must fall within the temporal interval introduced by the *in*-phrase.

The interval introduced by the *in*-phrase displays one interesting quantificational property. It seems that it must be at least non-cumulative for the sentence containing the *in*-phrase to be well-formed in an out-of-the-blue context. This is illustrated in (213) (in an out-of-the-blue context).

- (213) a. #John ate the sandwich in minutes.
 b. #John ate the sandwich in more than seven/many minutes.
 c. #In days, John decided to leave.
 d. #In more than seven/many days, John decided to leave.

In both positions, the *in*-phrase with a bare plural makes the sentences (213a, c) very difficult or impossible to interpret. With the quantifiers that derive cumulative non-divisive predicates, as in (213b, d), the sentences can be interpreted if a proper context is provided. However, the readings that such a context allows for involve the quantifier scoping relatively high, above the position in which the temporal adverbial modifies the eventuality. This means that at the level at which it modifies the eventuality, the *in*-phrase is interpreted with a bounded temporal interval. A discussion of this pattern of interpretation with the type of quantifier in (213) is provided in Chapter II, 4.4 and 4.5.

One additional reading that is available for (213a) with the quantifier *many*, is that it stands in contrast to few minutes, as in (214). However, examples such as this do not prove that the sentence is well-formed, since they involve pragmatic phenomena such as correction.

- (214) A: John ate the sandwich very quickly, in one or two minutes.
 B: No, he ate it in MANY minutes.

This further supports Krifka's argument that the adverbial is upward entailing and the effect related to Grice's Maxim of Quantity. If the *in*-phrase is upward entailing

in itself, then an upward entailing predicate in the measure that it specifies will cause a clash.

It is not clear, however, whether the interval is also required to be non-cumulative. Observe the examples in (215).

- (215) a. John ate the sandwich in less than seven minutes.
 b. (#)In less than seven days, John decided to leave.

The sentence in (215a) sounds better than those with a non-divisive cumulative complement in the *in*-phrase (213). The sentence in (215b), on the other hand, is quite bad. Both sentences, however, require support from the context, through some presupposition related to the meaning contributed by the *in*-phrase. This means that the readings that are available for these sentences involve a high scope of the relevant quantifiers, which further suggests that the divisive non-cumulative quantifiers, just like the cumulative non-divisive ones, cannot be interpreted inside the *in*-phrase in the position where it modifies the eventuality. In these readings, the interpretation of the interval in the position where the *in*-phrase modifies the eventuality is that of a variable, and therefore quantized. The interval in the *in*-phrase seems to universally be quantized.

If this observation is correct, it cannot entirely result from Grice's Maxim of Quantity. If the *in*-phrase specifies that the temporal interval of the eventuality is a part of the temporal interval in the *in*-phrase, then it is ambiguous between having the two identical intervals and having one as a proper part of the other. A downward entailing quantifier in the *in*-phrase specifies that the latter is the case, and it therefore provides some information about the quantity of the temporal interval of the eventuality. Grice's Maxim of Quantity would only derive these results if the *in*-phrase specified that the interval of the eventuality is a proper part of the one introduced in the *in*-phrase.

It is now clear why the *in*-phrase selects only for non-homogeneous eventualities. The central part of the meaning of the temporal *in*-phrase is that the interval of the eventuality is a part of the one introduced in the *in*-phrase. The interval of a homogeneous quantificational structure is also homogeneous, and therefore unbounded. On the other hand, at the level where the *in*-phrase modifies the eventuality, the interval introduced by the *in*-phrase must have an upper bound. It is impossible for an interval without an upper bound to be part of a bounded interval. This predicts that in fact, only eventualities with non-cumulative intervals can be modified by the *in*-phrase, because only such intervals can be part of other non-cumulative intervals. Choosing quantization over non-cumulativity, as suggested in the discussion above, also means that the eventualities modified by the *in*-phrase are required to have quantized temporal intervals. In terms of the present model, in which quantization of any aspect of the eventuality, from its narrow predicate to its temporal interval, happens at the level of the QP, this means that the *in*-phrase selects only for proper (i.e. non-empty) QPs. This is why the *in*-phrase is used as a test for verifying that an eventuality involves a proper QP. This explanation is close to that of Krifka (1989, 1992, 1998), but it takes a slightly different angle.⁶¹

⁶¹ This is yet another point for which the discussion in Chapter II, subsections 4.4 and 4.5 becomes relevant. In these subsections, I argue for identifying the set of divisive predicates with the set of

There is a type of eventuality which at first sight seems to escape the proposed definition for the meaning of the *in*-phrase. Observe the examples in (216).

- (216) a. John will smile at Mary in five seconds.
 b. In ten days, John will stay in this hotel.

In both cases, the verbs used in the eventualities suggest a stative interpretation: in (216a), John is in the state of smiling at Mary, and in (216b) he is in the state of staying in the hotel. However, bare states are homogeneous, i.e. unbounded, which should make them impossible to combine with the *in*-phrase.

A closer look at the interpretation of these sentences shows that they do not really have stative interpretations. The sentence in (216a) is true if all the initial parts of the eventuality of John smiling at Mary have non-empty intersections with the indicated period, and at least one final part of the interval of the eventuality does not. The same goes for (216b): its interpretation is that John's stay in the hotel started, and did not end, within the period of ten days. One of the effects of the *in*-phrase appears to be that it imposes a non-homogeneous interpretation on the eventuality. This can be done either by delimiting the interval of the eventuality, which is not what happens here (at least not overtly) or by imposing a telic structure with a singular marked in the QP.

What is less clear at this point is why the *in*-phrase imposes precisely an inchoative reading onto the otherwise statively interpreted eventuality (the state has to start within the relevant interval), and not a completive one (that it is also completed in this interval). In this respect, observe the examples in (217), where states are expressed through predicative sentences.

- (217) a. In ten minutes, John will be in bed.
 John was in bed in ten minutes.
 b. In seven years, John was ready to give up.
 John was ready to give up in seven years.

These sentences show the same pattern of interpretation: the starting point of the interval in which the state holds falls within the interval introduced by the *in*-phrase. Another way to formulate this is that in sentences combining a state with an *in*-phrase, the interpretation is that the state is 'reached' or 'established' during this period. This formulation makes the interpretation of the respective state in each of these sentences parallel to the interpretation of the result phrase in a singular telic eventuality. It is a state that is established at some point, and this point must be within the interval introduced by the *in*-phrase.

I therefore suggest that the structure of these eventualities is the same as that of telic unaccusatives: there is no specified agent and no predicates that specify the manner of initiating, but there is, however, an Undergoer and a result state, both properly specified. This is shown in (218).

cumulative predicates, and therefore also the set of non-homogeneous predicates with the set of quantized predicates. In any case, I continue to use the weaker notions of homogeneity and non-homogeneity throughout this chapter.

- (218) *In*-phrase imposing a telic structure:
 ‘In ten minutes, John will be in bed’

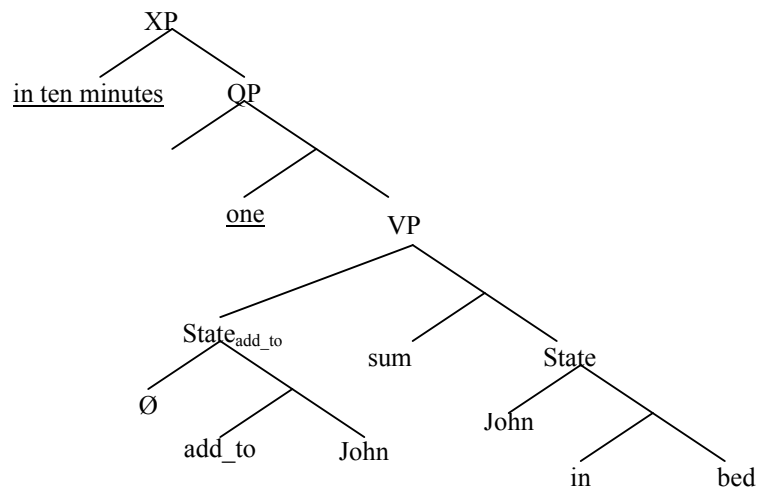

We expect that sentences of this type entail that the predicate expressed in the result state does not hold in the beginning of the interval introduced by the *in*-phrase. Observe in this respect (219), which shows these expectations are met.

- (219) a. When I came, John was in bed. #He was still in bed in ten minutes.
 b. When I came John was ready. #He got still ready in ten minutes.

In short, the *in*-phrase marks that the temporal interval of the eventuality is part of the temporal interval that the *in*-phrase introduces. This means that the interval of the eventuality must be bounded, i.e. that the *in*-phrase can only modify QPs, the projection that introduces boundaries to (the temporal interval of) the eventuality. The *in*-phrase can be present only if the modified structure is quantized, i.e. if the QP is not empty. A non-empty QP will further select a telic structure (a proper VP). Therefore, the presence of an *in*-phrase only allows for the interpretation that corresponds to a structure with two concatenated states.

2.6. The temporal nature of states

One of the questions this section deals with concerns the position at which an eventuality is assigned a temporal interval. The discussion based on the temporal adverbial PP with the preposition *for* has shown that, at least at the level of the QP, the interpretation of the eventuality involves a temporal interval. This same discussion pointed to some indications that even states have a certain measurable property. The strong conclusion is therefore that this measurable property is their temporal interval, i.e. that states have temporal intervals.

Another argument for bare state being assigned a temporal interval comes from the behavior of stative eventualities, such as those in (220). Stative eventualities lack both concatenation and quantification, but they can still be located with respect to some reference time (*eleven in the morning, very early*).

- (220) a. John slept until eleven in the morning.
 b. John was ready very early.

This does not exclude the option that the temporal trace is assigned to the eventuality at some other level, by a higher projection that takes the state as its complement. Even if this were the case, that level must be lower than outer aspect. In the present model, outer aspect, which relates an eventuality to the reference time, appears on top of the QP. This means that the candidates for assigning the temporal interval are the VP, the QP and the actual level of bare states.

The eventuality in the example in (220a) can be combined with the reference time in two ways. One is that the reference time contains both the interval of the eventuality and the interval determined in the temporal adverbial (eleven in the morning). In this case, we expect that within the reference time, the temporal interval of the eventuality is adjacent to the temporal interval in the adverbial. The other way is if the reference time is in fact determined by the adverbial. In the example, this would be an interval that is adjacent to the interval referred to by *eleven in the morning*. This means that the reference time within which one can attest that John sleeps is situated immediately before the interval denoted by *eleven in the morning*.

The former view of the reference time requires that the stative eventuality be bounded, which would require the projection of the QP. This introduces some serious complications to the model, since I have so far been assuming that most of the predicates that appear in the QP can only appear there if it projects over a VP (just as, with the exception of *much*, *little* and a few other quantifiers, Borer's 2005 nominal #P requires the projection of the CLP). But if there is a VP in the structure of the eventuality, it is not stative any more. This option would therefore require that examples such as (220) all involve a telic structure in which the state that they entail appears as one of the subevents.

The latter view does not raise this problem, since in this case the temporal adverbial directly modifies the reference time. The eventuality remains atelic. If this is the correct analysis, it also implies that the stative eventuality has a temporal interval; otherwise it could not be temporally ordered with respect to the reference time.

There is, however, one theory-internal element of the present model of eventualities which implies that states are in fact predicates with temporal traces. This element is the head of the initiating subevent in the telic template, which, in the full template, contains the predicate *add_to*. The predicate *add_to* introduces dynamicity: it marks that the value of a certain property of one of the participants is in a monotonic, continual change. In other words, the value of this participant is the value of a monotonically increasing or monotonically decreasing function over time. Time is therefore involved in the meaning of any state that contains the predicate *add_to*. But does the same hold for the 'stative' states, i.e. those that do not have the predicate *add_to*?

Before reaching a decision, I would like to address one further fundamental question about the telic template. The question is the following: what is the component that characterizes the class of predicate that I refer to as states? Many predications take part in the aggregate meaning of a clause. So far, I have been treating states as predicates, and the natural question is what makes these predicates

states. I provide a new definition of the predicate *add_to*, which makes it a component of every state. In this way, I take the predicate *add_to* to be the defining property of the class of states in the present model.

The immediate danger is that this will deprive us of the tool that is supposed to distinguish between what is usually called processes and proper states. This danger is avoided by postulating two different relevant types of the predicate *add_to*.

Henceforth, the definition of the predicate *add_to* in (221) will be used.

(221) *add_to* is a predicate that corresponds to a monotonic function from times to properties, which can be increasing, decreasing or constant.

Two of the three possible types of this function therefore derive processes and one derives proper states. They are all defined over time.⁶² This is shown in (222).

(222) Three possible types of the monotonic function *add_to*, with the form:

$$V = a * \text{time}$$

a. Increasing *add_to*
 $\text{add_to+}: a > 0$

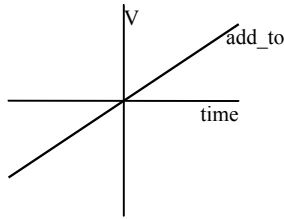

b. Decreasing *add_to*
 $\text{add_to-}: a < 0$

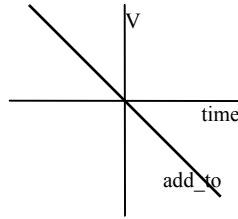

c. Flat *add_to*
 $\text{add_to0}: a = 0$

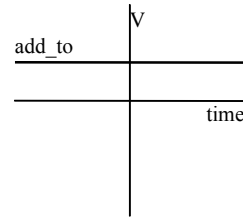

The predicate *add_to* always represents the same first order function of time ($V = a * \text{time}$), which maps atomic temporal intervals onto an ordered set of values V of a certain property. There are three interesting cases with respect to the value of the factor of time (a in the formula). If this factor has a positive value, the function is increasing and the predicate *add_to* marks that the value a certain property grows in time. If the factor has a negative value, the function is decreasing, i.e. the value of the property is falling. In both cases, dynamicity is involved, i.e. there is a homogeneous change. Finally, if this factor is zero, the function gives a constant value: it is flat. This means that the value of the property remains the same, and the state has no dynamicity. This is how proper states, involving no process, are derived.

To put it in more general model-theoretic terms, all core-atic eventualities involve the same function from time to properties. This is due to the fact that each particular value of a property is also itself a property (see Arsenijević 2005b for a technical solution for the relations between properties). In which case, processes are mappings of the type one-to-one (one temporal point, or one atomic interval, is mapped onto one property) and stative eventualities are mappings all-to-one (all

⁶² One could in fact choose a less specific definition, and say that this function is defined over any oriented linear structure, not necessarily time. Its temporal nature, and therefore also the temporal nature of the intervals associated with eventualities, could be a consequence of binding by the reference time. However, in that case, one would expect that instances of eventualities mapped over some other linear structure than time would also appear in natural language, in realizations that lack outer aspect, such as deverbal nominals and adjectives, which, to my knowledge, is not the case.

temporal points, or atomic intervals, are mapped onto one property). This very much corresponds to the actual intuition behind the division to states and processes, and at the same time presents a simple tool for a formal account of eventualities.

I do not further discuss the formal properties of my definition of the predicate *add_to*. Instead, let us consider some of the consequences of establishing such a definition for the model that I presented in Chapter III. Updated with the new definition of the predicate *add_to*, the full telic template looks as in (223).

(223) Telic template with the generalized predicate *add_to*: $V=a*time$

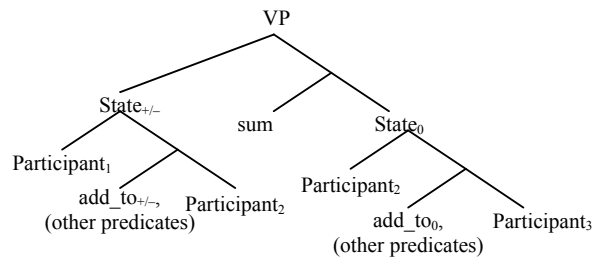

Both concatenated states contain the predicate *add_to* in their heads. The difference lies only in the fact that the result state involves the flat variant (*add_to_0*) and the initiating state the increasing or decreasing variant (*add_to_{+/-}*). Crucially, both states have temporal traces, by virtue of involving a function that is defined over time.

Summing up, every state contains the predicate *add_to*, and every state has a temporal trace.⁶³ The predicate *add_to* is in fact the one that introduces temporal intervals to predicates. At the same time, this predicate marks the relation between the predicate and the temporal trace that is assigned to it. Eventualities, including both stative and telic ones, are predicates defined over temporal intervals. Note that this is a stronger definition than one speaking only of predicates with temporal traces, since the predicate *add_to* also involves a direct relation between the value of some property involved in the predicate and the temporal trace.

Independently of the type of the predicate *add_to*, each state has a mass interpretation, and the interval of each state is therefore infinite and homogeneous. The VP is formed as the sum of two predicates with mass temporal intervals. The fact that the two states share one participant and assign two different, mutually exclusive values to one of its properties is restricting the sum to the concatenation. The most important effect of this relation is that the entire predicate is interpreted as a divided mass, parallel to the bare plural in the nominal domain, which is derived at the level of a classifier. The QP, which generates quantifiers, is projected on top of this structure. It imposes boundaries to the mass division.

The parallel addressed above, between the concatenation of a process and a state on the one hand and the combination (in fact intersection) of a classifier and a noun

⁶³ To be precise, and as already noted, the predicate *add_to* is not necessarily related to time. It is certainly related to a linear structure that corresponds to that of time, and maps from this structure to properties. It is possible that real temporal interpretation comes in only later, with the first temporal modifier (which assigns a temporal measure to this structure) or with the reference time. This is however orthogonal to the discussion and for clarity reasons I continue to refer to the temporality of the predicate *add_to*.

on the other, can be taken one step further. Since the subevent in the specifier of the telic template is a process (*add_{to+/-}*) and the subevent in the complement is stative (*add_{to0}*), the predicate *add_{to+/-}* can be seen as a counterpart of the property that makes a noun into a classifier. Observe that just as a process can appear alone, realizing an independent eventuality with a mass or iterative interpretation, many classifiers in Chinese can also appear alone as bare nouns, and receive a mass or bare plural interpretation. This is illustrated in (224).

- (224) a. John pushed the cart to the shop.
 b. John pushed the cart.
 c. Ngoheoimaai jat soeng zau aa Cantonese
 I go buy one CLbox wine SFP⁶⁴
 ‘I am going out to buy a box of wine.’
 d. Ngo heoi maai soeng aa
 I go buy box SFP
 ‘I am going out to buy boxes’ Joanna Sio, p.c.

A further similarity is that if an eventuality is quantified, counted for instance, it has to receive a telic interpretation. Similarly, a noun can be quantified only if it is in the complement of a CIP. In English, this is shown in the fact that only plurals can be quantified (with the exception of the singular form which shows agreement with its quantifier). In Chinese, this means that a noun can only be quantified if it has a classifier, even if the noun itself may appear elsewhere as a classifier. This is illustrated in (225).

- (225) a. John pushed three carts.
 b. Ngoheoi maai jat soeng Cantonese
 I go buy one box
 ‘I am going out to buy one box of whatever we were talking about’
 *‘I am going out to buy a box.’ Joanna Sio, p.c.

The sentence in (225a), with the reading in which there are three instances of the eventuality of pushing one cart, can only have the interpretation in which the temporal intervals of the three instances of the eventuality are delimited (i.e. they are either instantaneous or they have reached their result states). Each instance therefore involves a telic template, although with an unspecified result state. In other words, the only interpretation available for the process of John pushing the cart in (225a) is the one interpreting it as the specifier of the VP.

In (225b), the only available reading is the one in which *soeng* (box) is treated as a classifier, with an unspecified (i.e. elided) noun. The reading in which it is treated as a lexical noun is unavailable. Once more, the only available reading is that with the morpheme *soeng* (box) derived in the specifier of the CIP, the counterpart of the VP. The structural representations are given in (226). Crucially, in both structures, there is a quantifier that requires countability. This environment only allows the generation of the relevant element, i.e. the process of pushing and the unit of division *soeng* (box), in the specifier of the VP and the CIP, respectively.

⁶⁴ SFP stands for ‘sentence final particle’.

- (226) Structural representation of the relevant elements in (225)
 a. The structure of the VP *pushed three carts*

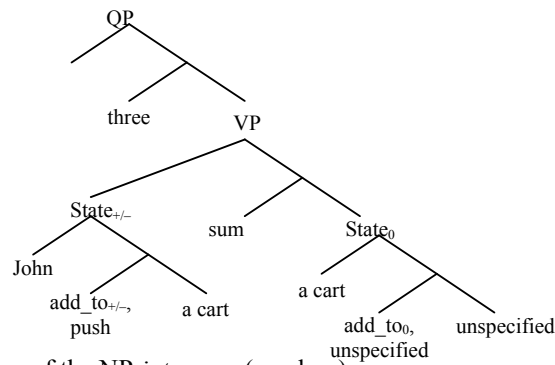

- b. Structure of the NP *jat soeng* (one box)

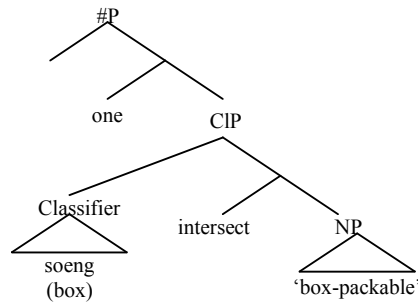

2.7. Summary

In this section I discussed questions related to the temporal interval of an eventuality. I first examined the nature of the relation between the temporal adverbials used in the tests for inner aspect and the structure of the eventuality. In doing so, I established a parallel between the eventualities in which the *for*-phrase measures only one subevent, and two phenomena of the VP domain, the causative and the progressive construction. The temporal modification of the result subevent displayed some similarities with causatives, and the temporal modification of the initiating subevent with progressives. The explanation that I proposed is that in all these cases, one of the subevents is quantified, losing its mass nature as a result. The consequence is that the aggregate eventuality can no longer completely conform to the telic template, resulting in a number of special interpretations.

I proposed that the *for*-phrase attaches to the QP, from where it assigns a light value to the head of this phrase. *For*-phrase cannot attach to a QP that has an independently generated quantifier in the QP, since it is not possible to assign two different predicates of the same kind to the same head. The *for*-phrase therefore indicates whether the structure that it attaches to already has a quantificational predicate or not. This falls in with the general approach of the model, where the inner aspect of an eventuality, related to homogeneity, directly reflects the presence or absence of a QP.

I followed earlier analyses of the *in*-phrase as a modifier that marks that the temporal interval of a telic eventuality is a part of the temporal interval introduced by the *in*-phrase. The *in*-phrase always introduces quantized, bounded intervals. A bounded interval can only have parts that are quantized as well, and an interval can be quantized in the present approach only if it is quantified (otherwise it is mass and therefore homogeneous). An eventuality has a quantified interval without any modification only if the eventuality itself is also quantified. This is why the *in*-phrase imposes a QP on the eventuality that it modifies.

In the end, I came back to the question of the level at which temporal intervals are introduced in the eventuality. I argued that the states that compose a telic template, and therefore also states in general, must have a temporal interval and that this temporal interval is what distinguishes a state from a bare predicate. This position allowed me to provide a very general definition of the predicate *add_to* as a function mapping from temporal intervals to properties. This function can be monotonic, giving rise to dynamic eventualities, or constant, yielding stative eventualities. The fact that this predicate, which is present in every eventuality, involves a component of time, means that eventualities in general are temporal.

3. Eventualities as arguments

3.1. Introduction

Ever since Davidson (1967), many linguists have viewed eventualities as arguments. For lexicalist approaches, they are arguments of the lexical verb; for other approaches, they are arguments of some predicate derived in the VP. Two approaches that consider eventualities to be arguments are presented in Chapter II (Krifka 1992, 1998 and Borer 2005b). Viewing eventualities as arguments is traditionally opposed to viewing them as composed units. The most influential approach along these lines is that of Verkuyl (1972, 1993 and many other publications), also presented in Chapter II. In compositional approaches, the eventuality is built in the VP, i.e. the meaning of the VP in fact corresponds to the eventuality.

The opposition introduced above is not very strong, extreme versions of the two types of approaches are quite rare. For instance, linguists who derive the predicate of the event argument in the VP, such as Borer (2005b), are in fact not so far removed from the compositional accounts. This is due to the fact that taking the meaning derived in the VP as the predicate of the event argument gives the event argument a special position with respect to the other arguments of the VP. Other arguments are derived and assigned descriptions in their own (usually nominal) expressions, while the event argument is described by the predicate derived in the VP in which it appears as an argument.

An important piece of general background for this entire opposition is the fact that nominal expressions are seen as typical arguments: units that are ontologically predestined to act as arguments. Therefore, they are usually assigned types that involve this ontological component. Argumenthood is thus seen as a primitive, a property related to certain types, and is therefore one of the fundamental elements of the theory that needs to be stipulated. The approaches that use event arguments in fact divide this property into two subproperties: the argumenthood of nominal expressions and the argumenthood of eventualities. Eventualities are therefore seen

as entities of a particular subtype that are assigned a certain kind of predicates, i.e. predicates describing eventualities. Note that the restriction of having the semantic nature of eventualities appears in both the event argument and the predicate that describes it, which indicates redundancy. In this view, also, the event argument is given a special status among the arguments of the verb. Other arguments introduce participants that take part in building the predicate of the eventuality, while the event argument is described by the entire predicate of the eventuality.

In this section, I present a view in which argumenthood is compositionally derived, rather than a primitive notion. I link argumenthood to the presence of the predicates introduced by the functional domains discussed in Chapter III, in particular division, quantification and specificity. It follows from the previous discussion that argumenthood can be derived both in nominal predicates and in eventualities. This means that both VPs and NPs can appear as arguments of other predicates. This way of viewing eventualities as arguments is crucially different than the Davidsonian view. While in Davidsonian approaches event arguments are arguments of the very predicates that derive their meaning, in the view I argue for eventualities can be arguments of predicates of other referential expressions, often actually predicates of other eventualities. Constraints on the appearance of an eventuality as an argument of another eventuality that can be observed, such as the fact that certain predicates only take nominal or verbal arguments, mostly pragmatic come from the real world knowledge, and rarely result from the syntactic or semantic nature of the arguments. I proceed by showing different problems can be solved intuitively once such a view is taken, in particular in application to the English progressive, perfect and causative forms.

3.2. Arguments and argumenthood

Although the notion of argument is very central in linguistics, formal definitions for this term are barely available in the literature. It is usually taken to be relative to the notion of a predicate. Syntacticians tend to see argumenthood as a semantically defined notion and semanticists would prefer to define it in syntactic terms.

The question of argumenthood is very explicitly tackled in Keenan (1974). Keenan observes arguments not only with respect to predicates, but also in relation to the more general notion of a function (he only considers one argument functions as the simplest case). Keenan singles out three relevant components, two of which can be extensional (the argument and the value of the function), and one of which is intensional (the meaning of the function).

One asymmetry between these three components is very strong, namely the asymmetry between the intensional meaning of the function on the one hand and its value and argument on the other. Using the most theory-neutral terms, the value and the argument of the function are seen as objects, as members of two sets: the co-domain and the domain of the function, respectively. The function itself is seen as having some procedural or other conceptual content which determines the mapping between the argument and the value of the function, or more generally between the domain and the co-domain.

The other asymmetry, which is the central topic of Keenan's paper, is the one between the argument and the value of the function. Keenan defines this relation as the *Functional Principle* (FP), which can be paraphrased as follows. The reference

of the argument is established independently of the function and its value, while the value of the function as well as the interpretation of its intensional meaning is always dependent on the reference of the argument.

For the purposes of this discussion, the FP can be analyzed into two important components: 1) the argument of a function must be referential and 2) the argument of a function must establish reference independently of the function.

The second component seems to relate very directly to the approaches in which the event argument receives its description from the predicate derived in the VP. This predicate determines the reference of the event argument, and it possibly embeds a number of other, usually nominal, arguments. Each of the embedded arguments has its own predicate through which it establishes reference. This means that the arguments of a VP with their own predicates are interpreted independently of the VP itself, while the event argument, which is defined by the predicate of the VP, is formed depending on the interpretation of all the embedded arguments. Restricting this view to the eventuality, the embedded arguments correspond to the arguments of a function, while the event argument corresponds to its value.

This means that argumenthood is a relative notion, which applies only when embedded structures are involved. If one predicate is embedded into another one, the embedder depends on the interpretation of the embedded predicate, which means that the embedded predicate displays argumenthood in this relation.

The first component of the FP, i.e. that the arguments of a function must be referential, opens space for a further reduction of the inventory. Reference, in the sense of the potential to receive an extensional meaning, is what characterizes arguments and their role in predication. If we manage to derive this property, the stipulated notion of argumenthood can be dispensed with completely.

While in the more standard Montagovian semantics (stemming from Montague 1973 and other works by the same author) and other set-theoretic approaches, the most primitive referents for lexical elements are entities and sets of entities, in the approach to nominal expressions in Borer (2005a), which I have in turn extended to eventualities, the most primitive referents are masses. In Borer's model, a bare lexical predicate refers to a mass, and a set-theoretic reference is derived by the functional predicates of division, quantification and specificity. The mass can therefore be divided, in which case it has a default kind-reference (as in *miners*, *apples*, *white dogs*), but may have other interpretations as well, and quantified, in which case it refers to bounded sets defined over divided masses (*six miners*, *many apples*, *every white dog*). Finally, a quantified predicate can be marked for some discourse- or context-related properties, such as being a singleton set for the given context (although its only member may be a non-singleton set) or being discourse-old. This is done by means of determiners, which mark specificity and definiteness.

Observe now the general structure, both in its NP and VP versions, as in (227).

(227) General structure of nominal and verbal referential phrases

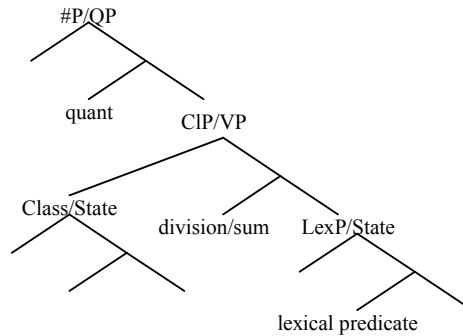

In the view presented so far, an argument underspecified for division, quantity or definiteness gets bound by the corresponding predicates in the c-commanding structure. This means that if a state appears as an argument of another eventuality, it will get bound by all its functional projections, and it will fully semantically incorporate in the predicate of that eventuality. This very fact can be seen as the reason of the ongoing debate on whether states receive event arguments (see Maienborn 2005 for an overview of arguments in this debate and the relevant references). The simplest structure of the verbal domain that can appear as an argument of another eventuality and show clear semantic and syntactic effects is the telic template. Therefore, in further discussion, I will only consider cases where a telic template or a quantified eventuality appears as an argument of another eventuality.⁶⁵

There are two important consequences of this view. One is that because argumenthood is a derived notion, based on the potential of some linguistic unit to establish reference independent of the bigger structure to which it belongs, in order to show effects of argumenthood, the observed structure has to minimally involve the predicate of division and/or the predicate of quantification. There are therefore indeed both nominal arguments and arguments derived over eventualities, and they have highly similar structures (the only differences are between division and sum and that eventualities establish reference through temporal intervals). In the view that I argue for, they are, however, not parallel in having an additional argument in their compositional structure that is described by the entire predicate of the expression, but in not having such an argument.⁶⁶

The other consequence has to do with the fact that both QPs and VPs are seen as arguments. Normally, the VP is the argument of the QP and both appear as

⁶⁵ Verkuyl (2000) argues in a more general way that the meaning of a VP can be referred to, and a VP can therefore be the argument of a verb. However, he only talks about referring to VPs through pronouns, and not of overt appearances of VPs in argument positions. Verkuyl's argument consists in showing that functions can generally be referred to by pronouns and that there is therefore no reason to introduce a primitive event argument to handle the fact that eventualities can be referred to by pronouns (one of the main arguments for event arguments in Davidson 1967).

⁶⁶ The effect whereby the highest functional projection in a referential expression (including nominal, verbal and clausal constructions) blocks the transparency of this expression for the predicates that take it as an argument closely corresponds to the effects captured in formal syntax by the notion of phase (Chomsky 2001). In fact, argumenthood and independent reference provide an intuitive explanation for this otherwise technical and stipulative notion.

arguments of outer aspect (of the predicate that relates their intervals with the reference time). However, there is nothing preventing them from appearing in the same positions in which normally nominal arguments appear: as arguments of states.

This latter consequence introduces the central topic of this section. In the remainder of the section, I discuss in further detail both the theoretical aspects and the empirical phenomena in which I argue that this effect is manifested.

3.3. The progressive

In subsection 2.2, I indicated that the progressive in English involves a special realization of the telic template. I now delve deeper into the discussion of the progressive, and then continue with a general discussion of the appearance of the VP and the QP in argument positions of other predicates and of the overt morphological and syntactic realizations of a number of elements in these structures.

Bennett and Partee (1972) proposed a view of the progressive that has ever since been a standard component of almost any theory of this type of aspectual meaning. They suggest that when a certain eventuality is operated by the progressive, the meaning that is derived corresponds to a part of the original eventuality (the one that the progressive applies to). Parsons (1990) is a little more specific. He presents a decompositional model of eventualities which distinguishes between states and processes, and in which telic eventualities are composed of one process and one state. Atelic eventualities in this model can be both states and processes without a result. Parsons defines the progressive as a form that takes an eventuality and gives back only its process component, but it gives it back as a state. Parsons uses the term *in-progress state* for this semantic output of the progressive.

There is indeed much in common between states and progressives. Even at a very shallow morpho-syntactic level, the progressive often takes stative auxiliaries, which is illustrated in (228). Furthermore, as (228b) shows, Dutch even has a preposition that introduces the VP (or, as I will later argue, the QP).

- (228) a. John is pushing the cart to the shop.
 b. Jan is het wagentje naar de winkel aan het duwen. Dutch
 Jan is the cart to the shop at the pushing
 ‘John is pushing the cart to the shop.’

Literally translated to English, the core of the Dutch progressive has the following form: *Jan is on/at the pushing*. Parallels between states and progressives extend on many other levels. For instance, both these categories render strongly degraded sentences when combined with aspectual verbs of the type *to begin/to finish*, as in (229).

- (229) a. ??/#John finished feeling strange.
 b. ??/#John finished being pushing the cart to the shop.

Finally, the progressive shares with stative eventualities its relevant mereological properties: they both display homogeneity in all tests, as illustrated in (230).

- (230) a. John felt strange for ten minutes/*in ten minutes.
 b. John was pushing the cart to the shop for ten minutes/*in ten minutes.⁶⁷
 c. John felt strange on Sunday and on Monday. (one interval)
 d. John was pushing the cart to the shop on Sunday and on Monday.
 (AMBIGUOUS, possibly one interval)
 e. John felt strange. → John has felt strange.
 f. John was pushing the cart to the shop. → John has been pushing the cart to the shop.

Therefore, if we also assume that progressives return a part of the eventuality that they apply to, and that they give back a process part in the form of a state, we need to ask what this state is, and how it is structured. This should not be the process itself, since a process has different properties from a state.⁶⁸ What is it then that can be presented as a state in the meaning of the progressive?

One candidate is the part-whole relation between the meaning that the progressive returns and the one that it takes. This is very close to the line that I take in proposing a structure for the progressive. I represent the progressive as a sum of one process and one telic eventuality, such that the denotation of the process is a possibly underspecified version of the initiating subevent in the telic eventuality. This structure is given in (231).

- (231) Structure of an eventuality with a progressive interpretation

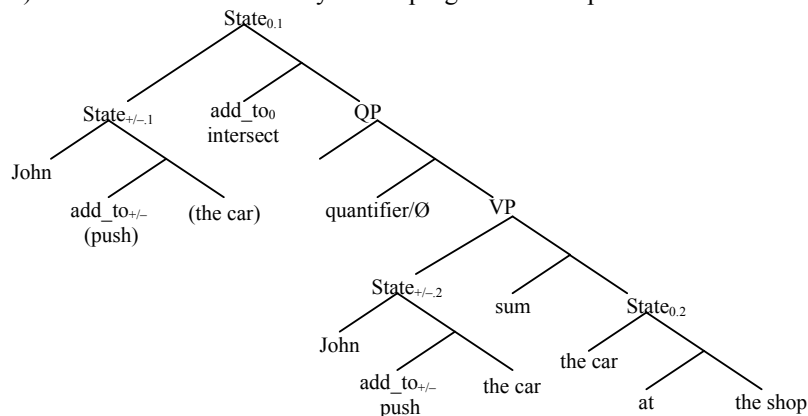

Observe first that the predicate *intersect*, just like the predicate *sum*, is an extremely primitive predicate which corresponds to one of the most fundamental mereological notions. The predicate *intersect* corresponds to the relation *overlap* (for a definition of *overlap*, see Krifka 1998), the mereological counterpart of the set-theoretic notion of intersection. The predicate *sum* corresponds to the operation *sum* (also defined in

⁶⁷ Here the only relevant scope of the adverbial is that over the progressive. The scope over the bare eventuality, in this case the telic eventuality of pushing the cart to the shop, is irrelevant for the observed problems.

⁶⁸ It is possible to change a process into a state by type-shifting, but this amounts to applying brutal force rather than proposing a solution to the problem.

Krifka 1998), the mereological counterpart of the set-theoretic notion of union. The two predicates, *intersect* and *sum*, can be mereologically defined as in (229).

(232) a. *intersect*: $\forall x, y [\text{intersect}(x, y) \Leftrightarrow \exists z. [z \leq x \wedge z \leq y]]$.

Predicate intersect holds for two objects if they share some part(s).

b. *sum*: $\forall x, y [\text{sum}(x, y) \Leftrightarrow \exists z [x \leq z \wedge y \leq z \wedge \neg \exists u [u \leq z \wedge \neg \text{intersect}(u, x) \wedge \neg \text{intersect}(u, y)]]]$.⁶⁹

Predicate sum holds for two objects x and y if they both are parts of a third object z and no part of z is such that it intersects neither with x nor with y.

Both these predicates present quite fundamental meanings in natural language. The predicate *intersect* is often argued to be the default and most primitive interpretation of the structure building procedures (see e.g. Pietroski 2002, Uriagereka 2002). For instance, all the predicates used restrictively, i.e. all the predicates of the sub-referential level, used to narrow down the domain of reference for an expression, are by default interpreted as intersecting, and other types of interpretation have to be explicitly marked.

Another primitive and often seen as default interpretation is the union, or disjunction, the counterpart of the mereological predicate *sum*, used in the telic template. In fact, the predicate *sum* can be seen as the second choice for the default interpretation of an unspecified predicative head. It is interpreted in the structure in (231) only after the interpretation of intersection appears inapplicable due to the disjunction of the two subevents (they assign two different, mutually exclusive, values to one of the properties of the shared argument). Since there is nothing in the specifier of the head of the State_{0,1} that is in a mutual exclusion relation with anything in the complement of this phrase, the structure can be freely interpreted as an intersection.⁷⁰ It can therefore be treated as projected by a head that is only specified for its stative nature (*add_to₀*), and which receives a default intersective interpretation.

The progressive is therefore the realization of a template under the label State_{0,1} in (231). This state takes two eventualities in its argument positions. One of them is a process (State_{+/-,1}) and the other is telic (the QP).

The QP represents the telic eventuality of John pushing the cart to the shop. It is a VP without an overt QP, so it receives a bare plural interpretation. The dynamic State_{+/-,1} in the specifier of State_{0,1} represents the process in which the dynamicity is contributed by John. This dynamicity, or process, can but does not necessarily have to be specified as achieved by pushing and relating to the cart.

The predicate *intersect* requires that there is an interval shared by the two eventualities, and this interval comes out as the interval of the denotation of the progressive (i.e. State_{0,1}). There must also be a predicative component that these two eventualities share. What does it mean for two eventualities to intersect, apart from their sharing a certain temporal interval? The intersection also requires that some material is shared by the predicates of these two eventualities, i.e. that there is a

⁶⁹ Krifka (1998) takes the *sum* operation as the most fundamental, and uses it to define other relevant notions. I take the *part* relation as the most fundamental one and use it to define other relevant notions, in particular the two relevant predicates, *intersect* and *sum*.

⁷⁰ The indices are: 0 for stativity, i.e. *add_to₀* nature and 1 to distinguish this state from the result state of the pushing eventuality.

predicate that appears as a component of both eventualities, and which is taken to hold in the intersecting interval. This is clearly allowed by the structures that represent the two intersecting eventualities: the predicate of $State_{+/-,1}$ is identical to (a part of) the predicate of $State_{+/-,2}$. This means that the set denoted by $State_{+/-,1}$ is a superset of the set denoted by $State_{+/-,2}$. The intersection therefore only contains those processes in which John is engaged in pushing and in which what this pushing affects is some property of the cart. This intersection is the meaning that is entailed by the template.

If the specifier of the predicate *intersect* is seen as the subject of the construction and the complement as the predicate, the aggregate interpretation can be paraphrased in the following way. A (part of a) certain underspecified process is described as one that leads to a certain result. It is not necessarily entailed, as shown in the following, that this result is indeed reached: what is crucial is that at the epistemic evaluation time the given description holds.

There are two more questions immediately following from the previous discussion. The first is: assuming that this is the correct structure, why is it that although the structural arguments of the predicate that projects the clause are eventualities, this structure derives a sentence in which arguments are the nominal expressions *John* and *the cart*? The structure shows that these two nominal expressions are structurally embedded in the direct arguments.

I only hint to two possible answers here, without going into a detailed discussion. One possible answer is most directly related to the subject, and to the fact that subjecthood is not only related to the position and interpretive properties internal to the VP, but also to some other aspects. Subjects are traditionally linked with finiteness (because finite verbs tend to agree with their subjects), but also with discourse-linking (Steedman 2000) and the aboutness of the clause (in the spirit of the Prague Circle tradition).

The other possible answer, which is more general, relates to the morphology and the lexical realization of certain structures. Many aspects of the meaning of morphological and structural case-endings show that they relate to the decompositional organization of the eventuality. For instance, the meanings of direction, goal, source, and undergoing a process are often assigned to certain morphological case-endings. At the same time, case-endings are traditionally, and also in this dissertation, associated with different ways of decomposing eventualities. It is therefore possible that case-endings specify some property related to the position in an eventuality in which the argument appears, irrespective of the level of embedding of the local eventuality. In the structure in (231), *John* receives the Case related to the specifier of a dynamic state and *the cart* takes the Case of the argument shared between the specifier of the result state and the complement of the initiating state. The fact that the observed states are deeply embedded in the predicate that projects the clause does not present a problem, since the other positions able to assign the same Case are filled with eventualities, which normally do not bear Case.

I will not at this point go into a deeper discussion of the mechanisms of case assignment and lexical realization of the presented structure since this reaches beyond the focus of this chapter. However, observe that in the English progressive, as illustrated in (233a-b) the verb surfaces in a form which can elsewhere be used as a noun or as a modifier (adjective or adverbial).

- (233) a. John is pushing the cart to the shop.
 b. John likes pushing the cart to the shop.
 c. John left singing.
 d. John is in the bed.

A possible and quite straightforward analysis would be to say that the progressive is a nominal or adjectival complement of the verb *be*. In this light, observe the parallel with (233d).

This can be seen even more clearly in Dutch.

- (234) a. Jan is aan het wachten. Dutch
 Jan is at the waiting
 'John is waiting.'
 b. Wachten is vermoeiend.
 waiting is tiring
 c. Jan zit aan de tafel.
 Jan sits at the table.

As in English, the Dutch progressive involves the verb in a form that appears in nominal positions, as shown in (234b). In addition, this form of the verb is introduced with a proper preposition and a proper determiner. This strongly indicates that the VP appears as an argument.

The other question relates to the referential properties of the three relevant eventualities $State_{0,1}$, $State_{+/-}$ and the QP. It is clear that outer aspect specifies the relation between the reference time and $State_{0,1}$. But, since as (235) shows, outer aspect c-commands the other two eventualities, the identical relation must be established for $State_{+/-}$ and the QP.

- (235) Possible representation of outer aspect over a progressive eventuality

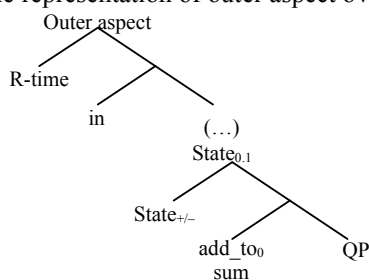

This is indeed the case. Both $State_{+/-}$ and the QP are bound by the outer aspect of $State_{0,1}$ and all three eventualities must therefore be such that the reference time belongs to their temporal intervals.

The binding that is going on between the outer aspect of $State_{0,1}$ and its two arguments $State_{+/-}$ and the QP is fully parallel to that between the quantification over the eventuality and the nonspecific nominal arguments. This means that due to the fact that they do not have their own outer aspect, the two eventualities appearing as arguments are generated as nonspecific and then bound by the referential properties of $State_{0,1}$.

Let us observe the interpretation that this derives for the sentence in (236).

(236) John was pushing the cart to the shop.

For this sentence to be true, the epistemic evaluation of the world at the reference time should register that there is one state of John's active engagement in a process and one quantified telic eventuality of John pushing the cart to the shop. It should further register that there is an intersection of these two eventualities. As I established above, this intersection is represented by the process of pushing the cart and its temporal interval.

In conclusion, we have an eventuality in the position of a nonspecific argument of another eventuality. The following subsection presents some empirical support for this idea.

3.4. The imperfective paradox

One of the most problematic aspects of the semantics and pragmatics of the progressive is the so-called imperfective paradox. Observe the sentence in (237).

(237) John was eating the sandwich.

Under the analysis of the progressive proposed above, the meaning of this sentence involves an eventuality that can be described as the intersection between a process of John acting (in general or even specifically with respect to the sandwich) and a quantified telic eventuality of John eating (and finishing!) the sandwich. The reference time is within the intervals of all three of these eventualities.

Now let us look at the passage in (238). Here, it is entailed that the relevant eventuality of eating a sandwich and finishing it did not really occur. A paradox is therefore involved: the first sentence entails an eventuality for which the second sentence entails that it did not occur.

(238) John was eating the sandwich. Before finishing it, he choked to death.

Many accounts have been offered for the imperfective paradox, and each of them has faced new problems (see Engelberg 2002 for an overview of the accounts and their problems).

This behavior of the progressive is, however, not so paradoxical in the present approach. This is due to two facts. One is that the eventuality of eating and finishing the sandwich is nonspecific, i.e. it has no reference in the discourse independently of the eventuality in which it is an argument ($State_{0,1}$). The other is that the reference time determines the point of the *epistemic evaluation* of the relevant world, i.e. the point at which it is evaluated whether the predicate of the eventuality holds. Reference time in these cases is located within the initiating subevent of the telic eventuality of eating the sandwich. At the point of epistemic evaluation, it will be registered that there is indeed an ongoing eventuality that is compatible with the description that involves eating a sandwich and finishing it.

This view is a variant of two approaches that have already been proposed. One is referred to as the *normality approach*, proposed by Dowty (1979), and the other as the *continuation approach*, originating in Vlach (1981).

Dowty introduces the notion of *inertia worlds*. Inertia worlds are identical to the actual world up to the point of epistemic evaluation and their futures are highly compatible with the current world. All inertia worlds in the given case must contain

the eventuality of eating and finishing the sandwich in order for the progressive sentence to be true. The worlds that contain choking to death are not considered to be inertia worlds because they all contain an unexpected interruption.

Vlach bases his approach on the occurrence of an interruption after the reference time. For him, a sentence in the progressive involving a telic eventuality is true if in all worlds that continue after the reference time without an interruption, the telic eventuality occurs.

The present approach provides a more technically elaborated account, which crucially relies on the nonspecificity of the eventuality of eating the sandwich. Being nonspecific, it has no independent reference in the discourse, and relies for all intents and purposes on the definition in the progressive structure. The progressive structure has its epistemic evaluation in an interval which is a part of that of the process of eating the sandwich. This process is highly compatible with the telic eventuality of eating the sandwich and finishing it: the predicate of the former is identical to the predicate of the initiating subevent of the latter. Hence, both eventualities properly describe the situation. For the telic predicate to be applicable, the reference time must fall within its initiating subevent and the telic predicate should not involve specificity.

In the second sentence, introducing the eventuality of choking, and therefore implying that no telic eventuality of eating the sandwich really occurred, the reference time is different. It falls after the interval of the process and it is possible to register that the process did not lead to the relevant result state. Clearly, it is no longer possible to use the same description for this process.

This strategy of solving the imperfective paradox is very similar to the one proposed in Ter Meulen (1995: 59-60). Ter Meulen's account is formulated in terms of the Discourse Representation Theory, while the one given here accommodates its general idea to the model argued for in Chapter III. Ter Meulen (1995) takes the interactions between the temporal interval of the eventuality and the reference time to be the central parameter of the aspectual semantics of a VP. She therefore fully derives the aspectual classification from the discourse-related properties of eventualities. Eventualities are divided according to their interaction with the flow of information, i.e. according to the relation established between the reference time and the temporal interval introduced by every new clause or sentence in the discourse. In this context, she argues that the solution to the imperfective paradox lies in the relation it establishes between the temporal intervals of the telic eventuality in the progressive and the one that implies that the telic eventuality was not completed. The model presented in Chapter III is less concerned with the discourse, the reference time and the flow of information, and more with the semantic and syntactic structure of the VP. Nevertheless, it is still highly compatible with the observations made about other domains, such as discourse structure and the flow of information.

Returning to the solution proposed for the imperfective paradox, I provide a further illustration of the relevance of nonspecificity. Observe the sentence in (239).

(239) ??At five, Rebecca was killing Jamaal but in the end, he wasn't dead.

(Engelberg 2002)

Engelberg uses this sentence to show that some verbs require that the telic eventuality involved in the progressive has taken place. Apart from the fact that as

shown in Chapter II, section 3.6, the verb *to kill* is quite special and even idiomatic in its behavior, which might have some effects here, the example shows two significant properties that could potentially cause the problematic behavior.

One is that the temporal modifier *in the end* offers at least an optional anaphoric reading with respect to the interval of the telic killing eventuality ('at the end of Rebecca killing Jamaal'). The end of the telic eventuality has to be after or at the time when the result state is reached, but it certainly cannot be within the initiating subevent. Moreover, even with other readings, the reference times of the two clauses are part of the same continuous interval and potentially intersect. The epistemic evaluation time for the whole sentence must contain both reference times. Therefore, at the epistemic evaluation time, it is a part of the discourse that the relevant telic eventuality of killing has not occurred in the actual world. It can therefore not be used for describing the situation in which Rebecca and Jamaal are involved.

The second property this example shows is that the sentence in its default reading seems to presuppose the telic eventuality of killing. The telic eventuality of Rebecca killing Jamaal seems to have been a part of the discourse before the sentence in (239) is introduced, and this sentence therefore only locates this topical element in time (distributing the known facts over temporal intervals). This is probably a consequence of the fronted temporal adverbials (*at five, in the end*), and the list-reading established between them. The second part of the sentence, entailing that the full telic eventuality of killing did not take place, contradicts a strong presupposition. In other words, the telic eventuality of killing is specific and definite, and it cannot be referred to and denied in the same sentence. This results in a strong pragmatic unacceptability. This is parallel to the sentence in (240), where a referent, which is described using a definite NP, is located in space, and then the existence of the definite NP used in its description is denied.

(240) ??One leg of the unicorn was knocking on the door and there was no unicorn in the world whatsoever.

A very similar situation to the one in (239), but this time without the presupposition of the telic eventuality of killing, is described by the passage in (241).

(241) At five, I looked at the street and Rebecca was killing Jamaal. I couldn't watch so I closed my eyes. When I looked again, Jamaal was running away.

Although the passage uses the same verb in the progressive form (*to kill*) and it is clear that no eventuality of killing has been completed, a number of speakers judges the passage acceptable.

It seems that even in simple past without any embedding, the entire progressive eventuality is specific, since the English past simple tense seems to impose specificity on eventualities. This specificity binds inside the eventuality and makes specific its arguments which are originally generated as nonspecific. This is probably what imposes the presupposition of the telic eventuality in the sentence in (239). In (241), however, the progressive is embedded under looking. It therefore avoids binding by specificity, and is probably also intensionally embedded.

The imperfective paradox can therefore be presented as resulting from three factors. One is that, as argued in Krifka (1998), eventualities are ways of describing

situations, and the same situation can be described by any eventuality that is compatible with it. This is of course conditioned by the pragmatic acceptability of the chosen description at the epistemic evaluation time.

The second is that the progressive over a telic eventuality places the epistemic evaluation within the temporal interval of the initiating subevent of the telic eventuality. If at the point of epistemic evaluation there is a process, any telic eventuality that can be the result of that process can be used to describe it. This makes the progressive of any telic eventuality that can be initiated by such a process true for the given epistemic evaluation.

Finally, the relevant telic eventuality under the progressive must be nonspecific in the given discourse. Otherwise, there is a strong presupposition in the discourse about whether the eventuality has occurred. The entire progressive, together with the telic eventuality, is externally bound by this specificity and the effects of the local nonspecificity in the progressive are overwritten.

At a later temporal interval of epistemic evaluation it may appear that the description used in the progressive is not appropriate, simply because this interval contains the ending of the process and it is clear and specific on whether or not the process has led to the relevant result. This includes the knowledge of whether or not the telic eventuality used in the description has taken place. If it has not occurred, the imperfective paradox effects will occur.

3.5. The perfect and the causative

I started the discussion of the progressive with an observation by Parsons (1990) that the progressive is a state of progress, or, in his words, the in-progress state. Parallel to this, Parsons also defines the English perfect, as in (242), as the *resultant state*. In other words, when an eventuality is in the perfect, this means that the result of this eventuality is directly entailed to hold with respect to a certain participant.

- (242) a. John has pushed the cart to the shop.
 b. John had pushed the cart to the shop.

In the sentence in (242a), the result of John pushing the cart to the shop holds at present, and in (242b) it already held at some point in past.

Without going into a deeper analysis, but drawing the same parallel as Parsons, the present model would derive the perfect in the structure in (243). The only difference with respect to the progressive is that the specifier of the predicate *intersect* takes the result subevent and not the initiating subevent of the telic eventuality which appears in the complement.

- (243) Structure of the perfect over a telic eventuality
 ‘John has pushed the cart to the shop.’

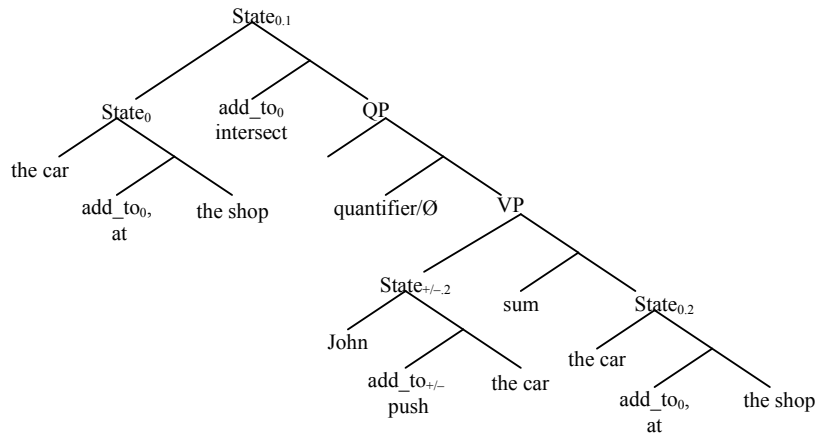

One direct consequence of the modification implemented to accommodate the perfect is that the reference time must be within the temporal interval of the result subevent, and thus a telic eventuality can be used only if it is fully realized. For the rest, the progressive and the perfect are equivalent, including the nonspecific nature of the telic eventuality.

One question arising from observing this structure concerns the structure of the perfect over an atelic eventuality, as in (244).

- (244) a. John has pushed the cart.
 b. John has screamed.

The answer that I argue for is that there is no such thing as perfect forms of atelic eventualities, and, even more, that there is also no such thing as progressive forms of atelic eventualities. Any eventuality that appears in the complement of the predicate *intersect* in the two structures introduced for these two forms must be telic.

Let me start with the most obvious case. The clearest case of atelic predicates certainly involves individual level predicates. Observe the sentences in (245). They can both only be interpreted if it is presupposed that John is changing his height in time.

- (245) a. #John is being tall.
 b. #John has been tall.

The same goes for all other states. Even stage level states, as in (246), can be interpreted in perfect and progressive forms only if they are taken as dynamic and leading to certain results.

- (246) a. John is being happy.
 b. John has been happy.

The progressive in (246a) is only acceptable if John is behaving in some happy way or if he is actively enjoying his happiness, if he is busy being happy. In both cases, being happy is seen as a dynamic predicate, i.e. a State with the predicate *add_{to_{+/-}}*, and not a proper stative eventuality. Whether or not the progressive also involves a

result is not completely obvious, but it is not excluded. From the point of view of pragmatics, every situation describable by a dynamic eventuality involves some change in the world, and each of the stages in this change can be used to enrich the description with a result subevent. Therefore, there is no clash with the possibility that eventualities in the progressive, which are at first sight stative, are in fact derived in the telic template.

The perfect form displays the inverse pattern. It most prominently entails a state, and it is more difficult to recognize the dynamic component. Along the lines of Parson's view, the perfect form in (246b) is interpreted as having the properties that come as a result of being happy during a bounded interval. The actual result properties are not fully unrestricted, but in fact context-bound. They involve a certain closed set of properties that are relevant for the context and can be a result of being happy. If being happy can lead to a result, which by definition involves a change, then being happy is dynamic in the given eventuality.

Together, these facts indicate that both the progressive and the perfect necessarily involve telic interpretations for the eventuality, even if the lexical verb or other elements may suggest an atelic reading. This view becomes even more plausible after observing that the dynamic component in the progressive in fact by rule involves an initiator with an active participation in the eventuality, and that dynamic eventualities involving a bare causation are unacceptable. The initiator must have control over the eventuality and non-animate holders of progressive states render unacceptable sentences, as in (247a).

- (247) a. #The car is being dirty.
b. The car has been dirty.

The sentence in (247a), involving a progressive of what is normally interpreted as a state, can have two interpretations. One is that the car is the Initiator of the telic eventuality. In this case, the car is actively being dirty (e.g. doing things that dirty cars do or indulging in its dirtiness, parallel to John's active happiness). This interpretation is grammatically available, but it is pragmatically excluded since cars normally do not do things, and they do not indulge. The other available interpretation is that the car is the Undergoer, a kind of an unaccusative reading (because it reads the subject as the Undergoer and not Initiator). In this reading, there is some process initiated by some other participant, such that it affects the dirtiness of the car. This reading is not available because it has dirtiness as a proper state, not as a process. Making dirtiness a process apparently requires an active initiator, which will coerce a state into an action.

This is linked with the fact that the progressive is based on having (a superset of) the initiating subevent of a telic eventuality in the specifier of the predicate *intersect* (i.e. of State_{0,1}) so that the telic eventuality and the progressive have identical specifiers. In order to mark this aspect of its template, the progressive requires an Initiator, either as an overt NP or as a variable in the relevant position. The 'unaccusative' reading of the sentence in (247a) involves a fully unspecified Initiator, whose position is overtly filled by the actual Undergoer. The exclusion of the Initiator from the interpretation of the eventuality also excludes the possibility of properly forming the progressive template.

The perfect, in which the result subevent of the telic eventuality has an analogous role to the initiating subevent in the progressive (it appears in the specifier of the perfect template and in the telic eventuality in its complement), has no restrictions of the kind described for the progressive. This is expected, since in the perfect, it is important that the Undergoer of the telic eventuality is specified, either by an overt NP or by a variable. The subject of an eventuality that is normally interpreted as a state, when it appears in the perfect, is always understood as the Undergoer, and the Undergoer is therefore always specified. This is due to the fact that eventualities that are normally interpreted as states do not have unergative variants, where the Undergoer would be missing. Moreover, even if they did, unergatives do not really lack an undergoer, as unaccusatives do; rather, theirs is incorporated in the verb (see discussion in 2.1).

The template proposed for the progressive and the perfect displays one important constraint that has not been syntactically or semantically motivated. As noted above, and as shown in (248), the eventuality in the specifier of the template must be a superset of one of the subevents in the telic eventuality in the complement of the template. In addition, these two elements must have coreferential specifiers (in (248), this is the Participant₁ in State_x, which also appears in the specifier of State_{y/z} for the progressive, or of State_{z/y} for the perfect). The question is why these constraints hold, i.e. are there structures that only partially match the template and what interpretations do they derive?

(248) General pattern for progressives and perfect forms⁷¹

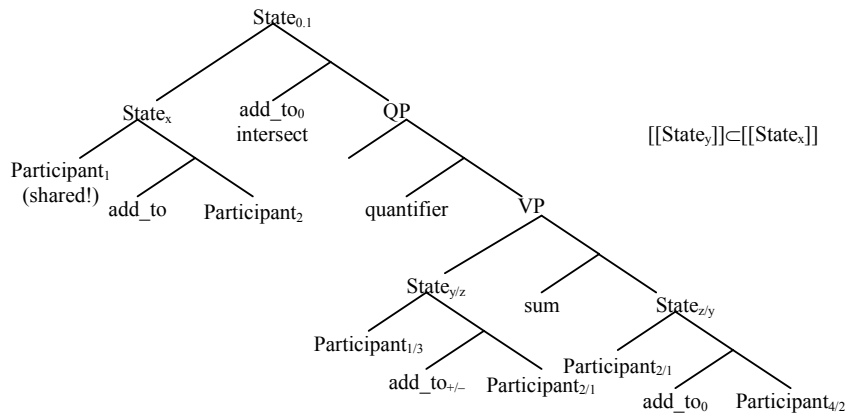

The major elements of the pattern are the predicate *intersect*, the subset relation between the eventuality in the specifier of the template and one of the subevents in the complement, the coreference between the specifiers of these two eventualities and the telicity of the eventuality in the complement of the template.

I already discussed the predicate *intersect*, and suggested that it is the default, or the lightest, predicate in natural language.⁷² In other words, the interpretation of

⁷¹ The index before the slash is for the progressive and the one after is for the perfect form.

intersection emerges between two arguments whenever it is possible and whenever no other interpretation is overtly marked. This means that some other predicate can also appear in the template, but this would result in a different interpretation, determined by this predicate.

The subset relation between the eventuality in the specifier of the predicate *intersect* and one of the subevents in the complement of this predicate can be motivated both by the formal properties of the structure and by its pragmatics. The formal factor is the requirement that the intersection determined by the predicate of the template not be empty, since otherwise the template would derive concatenation. The constraint therefore guarantees a non-empty intersection: if one subevent in the telic template is part of the eventuality in the specifier of the template, the intersection amounts to the subevent of the telic template. Coreference between the specifiers guarantees that they also share at least one argument (Participant₁ in (248)).

The telicity of the eventuality in the complement of the template in fact only represents a special case of intersection between eventualities. If both intersecting eventualities are states, what is derived is a state entailing that the predicates of the two intersecting states hold simultaneously. In other words, the result is another simple state, and not a particularly interesting structure. The template that I described in this section is actually just one special case of intersection, which involves a telic eventuality and its non-empty intersection with an atelic one. This special case realizes a pragmatically very prominent and frequently used semantic pattern in which only part of a telic eventuality is singled out and referred to. This is why this semantic pattern in many languages also has corresponding lexical elements, and appears as a syntactic construction.

Many other structures, which do not satisfy all the requirements of the template also appear in language, and, if pragmatically feasible, receive a linguistic realization. Some of them are also pragmatically prominent, which triggers the development of corresponding lexical units and syntactic constructions. More patterns of this kind are presented in the following section, which is concerned with Slavic prefixes. However, most other structures have to use the available lexical material, and therefore also the corresponding set of constructions. The simplest among them is the telic template, which only takes nominal arguments. This means that in many cases eventualities must be nominalized in order to appear as arguments in other eventualities. Such is the case in the examples in (249).

- (249) a. John's killing of Mary inspired Bill's writing of a poem.
 b. John's happiness surprised Mary.

In such a view, the progressive and the perfect, as well as some other forms, present special templates of eventualities, which are more or less idiomatically related to certain morphemes.

⁷² H. Reckman (p.c.) suggests that the intersective interpretation is more pragmatically fundamental than the sum because intersection narrows down the reference set, while sum expands it. In the context of the general communicative tendency to refer precisely, to sets smaller than the universe, this property makes conjunction and intersection more fundamental than disjunction and sum/union.

Another template that is found in many languages is the one that derives causatives. As argued in subsection 2.2, causatives are telic eventualities that include non-stative result subevents. The corresponding structure is given in (250).

(250) Structure of (one type of) causatives

a. The full causative tree

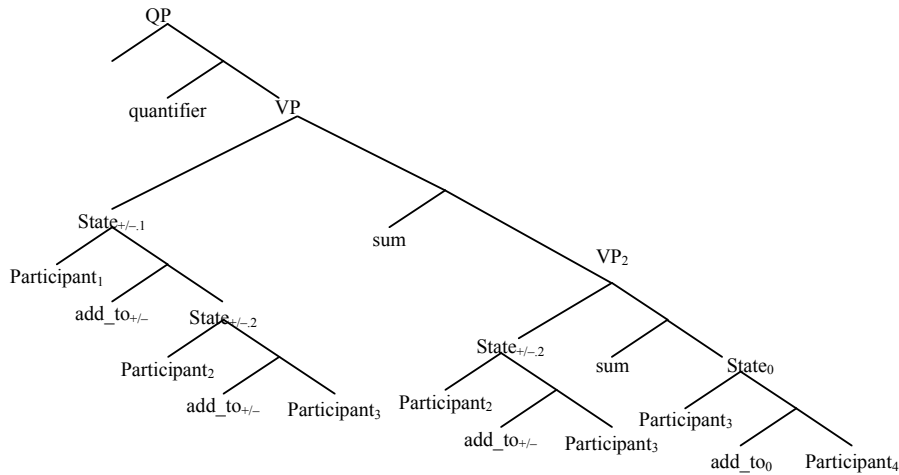

b. Causative tree with only the most relevant nodes

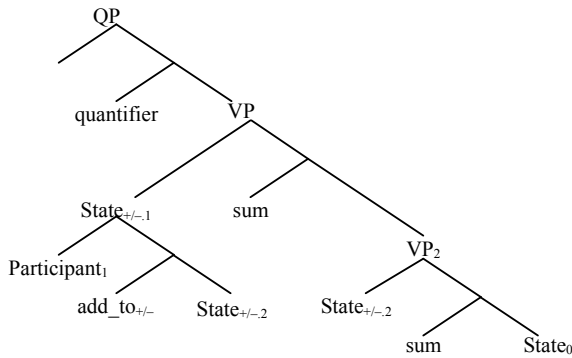

The only difference with respect to the simple telic template is that the result subevent (here VP_2) is not a state but a telic eventuality. The rest of the structure is just as with the regular telic template: the predicate of the VP is *sum*, the complement of the initiating subevent (i.e. of $State_{+/-,1}$) is the specifier of the result subevent (VP_2), here labelled as $State_{+/-,2}$ and the telic eventuality further projects a QP.

As observed in subsection 2.2 in relation to the examples repeated in (251), there is an additional restriction in English causatives: they require a very light predicate in the head of their VP.

- (251) a. John made/??sang Mary close the door.
 b. John made/??laughed Mary go to London.

This can be explained by the fact that the predicates bearing conceptual meanings, the so-called lexical prefixes, tend to appear only in the bottom of the tree, in the most deeply embedded phrase within the main line of projection (see Borer 2005a, b for an elaborated argument along these lines). A different way of putting this is to say that lexical verbs, as argued in Harley (2003), represent a set of functional predicates, and simultaneously incorporate some manner modifiers. At the level of the causative template, the embedded eventuality appears as an argument which has an independent reference, i.e. an independent interpretation. It seems that this also results in an independent lexical insertion, or even phonological realization. Therefore, the lexical verb cannot incorporate manner modifiers of any level higher than the eventuality in which it is generated.

3.6. Summary

In this section, I started out by presenting a compositional view of the phenomenon of argumenthood. In this view, eventualities semantically have as much potential for appearing in argument positions as do nominal expressions. All the asymmetries that occur are due to pragmatic factors and lexical restrictions, for instance in taking case-endings.

I then presented a number of templates which take eventualities as their arguments. I first presented and discussed the progressive, which denotes an intersection between a process and a telic eventuality, derived under certain constraints. I showed that this provides the right interpretation for the progressive and even offers an explanation for the imperfective paradox.

Having the result subevent of the telic eventualities as the locus of the intersection in this template provides a structure for English perfect forms.

The two templates were presented as two syntactic structures that have a special status due to their pragmatic prominence and the availability of the lexical material that allows non-nominalized eventualities to appear in argument positions.

A third template of the same kind is proposed for the causative construction. This template is an augmented version of the regular telic template, i.e. it represents a telic template which has another telic template as its result subevent. The Undergoer of the causative eventuality is therefore the initiating state of the telic eventuality appearing as the result of the causative.

4. Conclusion

In this chapter, I presented two interesting aspects of the model proposed in Chapter III, its temporal nature and its relation to the notion of argumenthood. I used this discussion to shed more light onto the more basic properties of the model, providing a formal definition of the notion of states, as used in Chapter III, and offering a structural account for the semantics of the progressive, the perfect and the causative in English.

In the first part of the chapter I presented earlier accounts of the *for-* and *in-*phrases, used as tests of inner aspect, and some novel views stemming from the model developed in Chapter III. The discussion of the *for-* and *in-*phrases led to the conclusion that in the structure developed for eventualities, temporal intervals are already assigned at the level of the states. In this way, temporal intervals, can be

seen as the categorial property of the verbal category, the one in which the meanings associated with VPs crucially differ from those derived by the nominal category.

In the second part of the chapter I discussed the notion of argumenthood with respect to the model presented in Chapter III, concentrating especially to the English forms of progressive, perfect and causative. The discussion of the progressive and perfect forms lead to a model in which eventualities appear in the argument positions of other eventualities. Causative structures were shown to be part of the same paradigm.

The model presented in Chapter III has been further specified in the following way. Temporal intervals are introduced by the predicate *add_to*, which is universally present in every state, end therefore in every structure in which a state appears as a building unit. States, the elementary eventualities, can be used to build a semantically richer structure when they appear as arguments of the predicates *intersect* and *sum*. The predicate *intersect* is the default predicate. If pragmatically well-formed, a structure formed over this predicate, with two states as arguments, results in the intersection of the two states. This meaning corresponds to a new state, with a richer predicate and a larger number of arguments.

However, in one special case, a structure with special properties is derived. This case appears when the two states in the argument positions of this light two-place predicate are such that they cannot share any parts of their temporal intervals (i.e. they have an empty intersection). In the typical case, this happens because the two states share one argument and assign two different, mutually exclusive, values to one of its properties. Their intersection is empty, making the intersective interpretation informationally vacuous. For this reason, the two-place predicate gets the next available default interpretation: that of a sum, which due to the fact that the states are disjoint and have temporal intervals, appears as a concatenation, resulting in the pattern introduced in Chapter III as the telic template.

The case in which the telic template is derived is not coded as a requirement of some part of grammar. Rather, it is viewed as one possible case, and only when it accidentally appears will a telic template be formed. Other cases either derive one single state, by intersection, or some other, less interesting, special structures. The case of the telic template has certain very important properties both at the levels of semantics and pragmatics. For instance, it structurally derives the meaning of change. This makes it a very frequent and prominent unit. A further consequence is that a set of functional and lexical elements emerges in the lexicon, which corresponds to the minimal semantic contents of the template, and therefore also to its syntactic skeleton.

The arguments of the telic template in its default form are states. One state appears in its specifier and the other in its complement. The model defines states as predications involving two direct arguments and the predicate *add_to*. This predicate presents a linear mapping from time to properties, and has two different interesting variants, the one-to-one mapping and the all-to-one mapping. The former corresponds to dynamic states, or processes, and the latter to stative eventualities.

This definition implies that states are assigned temporal intervals. Therefore, the entire structure built over them also has a temporal interval. One consequence is that this structure can establish reference based on its temporal interval, and therefore project a verbal instead of a nominal category.

Temporal intervals of states are fully unstructured, and therefore also unbounded and undivided. Parallel to the effects of the nominal functional domain, states can undergo division (in the telic template) and quantification (by a quantifying predicate that projects the QP). The telic template is not the only possible way to define a canonical singular and to introduce division in the structure of a state, but, as explained above, it appears as the most frequent, most universal, one.

The ordering between the two states that appear in the telic template is determined structurally by the argument that they share. The state that has the shared argument (the Undergoer) in its specifier will appear as the complement of the VP and the one that has it in the complement as the specifier of the VP. When a certain predication corresponds to the telic template, except for involving sharing of more than one property, the same predication can be described through different possible structures. Each of them has only one property as the base for the telic template.

The fact that the properties of the telic template are not requirements but just possible cases, and that other cases are possible as well, also extends to the atelic nature of the arguments of the template. Eventualities of other levels of structural richness can also appear in these positions. Such is the case with VPs and QPs. However, in those cases, the derived structures are not proper telic templates, but different specific variants. These variants are less uniform and less universal cross-linguistically, due to their lower degree of pragmatic frequency and prominence. This is for instance the case with causatives, progressives and perfect verb forms.

This presents the telic template not as a structure that is universally encoded in the grammar, but rather as a construction which corresponds to a pragmatically prominent pattern, because it derives the meaning of change and establishes temporal reference. Both these semantic effects are quite frequent and important in human communication. At the same time, it is a structure that defines a canonical singular and derives mass division, therefore also possibly subject to quantification, which makes it prominent both in semantics and in pragmatics. For these reasons, the lexicon has developed functional and lexical units and categories, which lexicalize parts of this construction and provide simpler ways for it to be realized.

Chapter V: Serbo-Croatian verb-affixes

1. Introduction

So far, the dissertation has been quite theoretical, providing observations of general phenomena related to eventualities and their syntactic and semantic nature, and based mainly on the English and Dutch paradigms and examples. In this chapter, I present and discuss data from a different aspectual system, as found in Slavic languages. The chapter discusses a narrower and more empirically oriented set of problems in the domain of the syntax and semantics of eventualities. The central topic of this chapter is the system of verb-affixes in Slavic languages, more precisely in Serbo-Croatian (S-C). The relation between verb-particles and aspect has been at the centre of the study of aspect since its beginnings, and it therefore also represents quite an important domain in the research on event structure.

Slavic languages have a rich morphological marking of aspect. Aspectual meanings can be marked by verb suffixes, or they can be associated with the presence or absence of prefixes attached to the verb, as illustrated in (252).

- (252) a. Jovan je gur-ao^I kolica.
 Jovan AUX push-PTC cart
 ‘Jovan was pushing the cart.’
 b. Jovan je od-gur-ao^P kolica.
 Jovan AUX away-push-PTC cart
 ‘Jovan pushed the cart away.’
 c. Jovan je od-gur-av-ao^I kolica.
 Jovan AUX away-push-I_suff-PTC cart
 ‘Jovan was pushing the cart away.’
 d. Jovan je iz-od-gur-av-ao^P kolica.
 Jovan AUX out-away-push-I_suff-PTC cart
 ‘Jovan completed the/some eventuality of pushing (the) carts away.’

Before I continue, two remarks are due. One is that traditionally Slavic verbs are divided to two classes: there are perfective and imperfective verbs. Although there is no consensus on the direct mapping between these two values and those used in theories of inner aspect, imperfective verbs can be seen as related to atelicity, or homogeneity, and perfective ones to telicity, or quantization. To start with, I will therefore be using the labels ‘perfective’ and ‘imperfective’, while later I propose an analysis that dispenses with these terms and deals only with those defined in Chapter III. On the technical side, the superscripts ‘I’ and ‘P’ following the verb are used to mark the imperfective and perfective forms, respectively.

The other remark is that it is also possible to translate (252c) as ‘Jovan pushed the cart away’, but allowing only for the iterative reading of this translation. The lack of a singular telic reading for the S-C example makes this translation incomplete. The translation that is provided in the example, which uses the English present continuous form, has both the readings of the S-C sentence. The readings are a) that there is a singular eventuality of pushing the cart away in a progressive interpretation (i.e. only its initiating subevent is really entailed), and b) that there is an unbounded set of iterations of a full telic eventuality (bare plural reading). Recall

that with respect to the progressive, the same two types of reading were available. Based on this parallel, some authors, such as Borer (2005b), have claimed that the imperfective suffix *-va* corresponds to the English progressive.

As (252) shows, the stem verb is normally imperfective (there are exceptions, which I will not discuss here). Adding a prefix to a stem verb contributes a lexical meaning (often even causing a shift in the lexical meaning of the verb), and it makes the verb perfective. The literature on prefixes is divided as to whether the prefixes mark perfectivity or whether they are simply a lexical semantic component and perfectivity is a consequence of some structural properties that the prefixes involve (see for instance Filip 2003 and Gehrke 2005b). Adding a suffix to a perfective verb (even to a perfective stem verb) makes the verb imperfective. The suffix does not contribute any lexical meaning and does not cause any semantic shifts in the meaning of the verb. Therefore, it is uncontroversially taken as an aspectual marker. It is less uncontroversial, however, what the suffix marks exactly. Finally, there is also a group of prefixes which can appear on a verb that already has a prefix and a suffix, as in (252d). Verbs with two layers of prefixes and a suffix are perfective, which means that this latter type of prefixes is associated with some position that scopes over the imperfective suffix.

Žaucer (2002) convincingly argues that verb prefixes in Slovenian are all stative, i.e. that they do not represent dynamic notions, like for instance paths. His arguments hold equally well for S-C. Observe the examples in (253). Prefix *iz-* (out) in this view corresponds to the state of being outside and the prefix *do-* (at/to) corresponds to the state of being at some place.

- (253) a. Jovan je iz-bacio psa .
 Jovan AUX out-threw dog.ACC
 ‘Jovan threw the dog out.’
 b. Jovan je do-vezao kola.
 Jovan AUX to-drive car.ACC
 ‘Jovan brought the car by driving.’

Not only for the Slavic languages, but also more generally, verb prefixes and (separable) verb particles are often associated with resultative meanings (see for instance Lüdeling 1998). With respect to Slavic languages, this has been most explicitly put forward in Gehrke (2005a) and Arsenijević (to appear, a). Both these papers argue that verb prefixes in Slavic languages are generally resultative. The state of the dog being out of something in (253) is therefore viewed as the result of the telic eventuality of throwing the dog and the state of the car being at some place is the result of driving the car to that place.

In the model presented in Chapter III, this means that all verb prefixes are derived as (parts of) the predicates of the result subevent. This is indeed what I argue for in this chapter. I present the major mechanisms of this analysis and go through some of the possible problems for the particular technical account presented here. For a more general discussion of the claim that Slavic prefixes are resultative, see the cited works of Gehrke and Arsenijević.

2. S-C affixes in the telic template

2.1. Arguments of the prefixes

Let us now take a look at how verb prefixes are generated. In this subsection, I only look at the so-called internal (DiSciullo and Slabakova 2005) or lexical (Svenonius 2004) prefixes. To avoid the entire issue of the division to the internal and external prefixes at this point, I take internal prefixes to be those which assign perfectivity that can be neutralized by the imperfective suffix *-va*, i.e. those of the type in (254b), and external prefixes as those which make the verb perfective irrespective of the presence of the suffix *-va*, as in (254d).

- (254) a. Jovan je gur-ao^I kolica.
 Jovan AUX push-PTC cart
 ‘Jovan was pushing the cart.’
 b. Jovan je od-gur-ao^P kolica.
 Jovan AUX away-push-PTC cart
 ‘Jovan pushed the cart away.’
 c. Jovan je od-gura-va-o^I kolica.
 Jovan AUX away-push-I_suff-PTC cart
 ‘Jovan was pushing the cart away.’
 d. Jovan je iz-od-gura-va-o^P kolica.
 Jovan AUX out-away-push-I_suff-PTC cart
 ‘Jovan completed the/some eventuality of pushing (the) carts away.’

Later in this section I extend the proposed analysis to external prefixes as well.

I analyze internal prefixes as lexicalizations of (parts of) the predicates of the result subevent. This means that their generation is conditioned by the projection of the full VP, and they are generated in the head of the resultative phrase. This is shown in (255) for one of the previous examples.

(255) Structural representation of verb prefixes in the telic template

Jovan je iz-bacio psa .
 Jovan AUX out-threw dog.ACC
 ‘Jovan threw the dog out.’

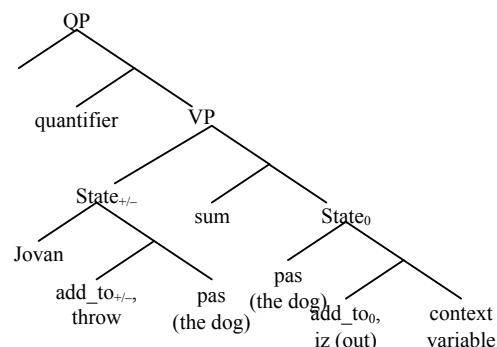

The eventuality is decomposed into the initiating subevent in which Jovan performs an action with respect to the dog and the result subevent in which the dog is out of

some contextually determined place (such that it contains the previous location of the dog).⁷³ I assume, however, following the arguments put forth in Stanley (2002) and Marty (2003), that at least some of the contextually given information is part of the syntactic and semantic representation of the sentence. Such is for instance the case with the VPs that overtly specify only the Source or only the Goal. I assume that in such cases the ‘missing’ participant is present in the representation of the VP and elided in the phonological representation. Ellipsis is licensed by the fact that the elided material is strongly determined in the context.⁷⁴

This general approach to prefixes is not particularly new: it is in many ways similar to the approaches of Ramchand (2004) and Svenonius (2004). However, the views of the suffix and the external prefixes that I present are significantly different from the two cited approaches.

The generalization that can be made about the arguments of (the predicates represented by) the prefixes, based on the hypothesis that they are always generated in the result subevent, is given in (256).

- (256) The specifier (the subject) of the prefix is always the Undergoer and the complement (the object) of the prefix is always the Goal.

This is a strong prediction, and therefore a highly falsifiable one. Let us therefore look at the possible empirical arguments against it.

The first type of data that might seem to clash with (256) is represented in the sentence in (257b). Observe first (257a). It fits very well in the structure in (255), and the PP *iz sobe* (out of the room) introduces a proper object for the result predicate *iz* (out), one that is even introduced by the same morpheme, this time appearing as a preposition.

- (257) a. Jovan je iz-bacio psa iz sobe.
 Jovan AUX out-threw dog.ACC out room.GEN
 ‘Jovan threw the dog out of the room.’
 b. Jovan je iz-bacio psa napolje /na ulicu.
 Jovan AUX out-threw dog.ACC outside on street
 ‘Jovan threw the dog into the outside/on the street.’

In (257b) however, the adverbial that determines the result location of the dog does not involve the semantic component introduced by the prefix. While the prefix marks the location out of something, the adverbials, which both introduce the goal, mark locations that are perceived as being at or on some place (the adverb *napolje*,

⁷³ I will not discuss the syntactic mechanisms that drive the surface realization of the prefix. The structure however offers several possibilities. One is for instance the head-movement of the verb (à la Travis 1984). Another is through agreement between the head of the VP and the head of its result state (the same agreement might be resulting in the Accusative on the Undergoer).

⁷⁴ This is related to the observations I made in Chapter II subsection 3.6, concerning the fact that the presence of a Path, Goal or Source licenses the mapping of the direct object. In terms of the present model, this can be reformulated in the following way. The presence of a Path, Goal or Source allows for interpreting the quantification on a nonspecific direct object as a reflex of the quantification over the eventuality. The explanation that the model offers is that these roles signal the presence of the telic template, which is in turn required in order to project a QP with the relevant quantifiers. When these roles are not present, the eventuality is at least ambiguous between its telic and atelic interpretations.

meaning ‘outside’, is literally derived as *on* + *field*). Judging from the prefix, the predicate of the result phrase should be *out*, but judging from the Goal participants, the predicate should be *on* or *at*. This causes a problem for the proposed analysis.

To make it even more complicated, it is possible to combine two goal phrases, one that fits the predicate of the prefix, and one that does not. This is illustrated in (258).

- (258) Jovan je iz-bacio psa iz sobe na ulicu.
 Jovan AUX out-threw dog.ACC out room.GEN on street
 ‘Jovan threw the dog out of the room, onto the street.’

But this behavior is in fact very restricted, and occurs only with some prefixes, such as *od-* (from at), *iz-* (out), *sa-* (from on). Prefixes such as *u-* (in), *na-* (on) or *pod-* (under) result in odd sentences when combined with different prepositions. This is illustrated in (259).

- (259) a. ??Jovan je u-bacio knjigu na sto.
 Jovan AUX in-threw book.ACC on desk
 b. ??Jovan je pod-vukao kola na ulicu.
 Jovan AUX under-pull car.ACC on street

The two sentences in (259) are acceptable if the context strongly suggests the exact objects of respectively throwing in and pulling under, and these are simply elided in the given sentences. Otherwise, the sentences are unacceptable.

Let us therefore take the sentence in (259a) in the context in which it is clear that Jovan throws the book into some container, for instance the office. The underlying form of the sentence, before the ellipsis, would then be as in (260). In this case, it is clear that the PP *na sto* (on the desk) needs to introduce a location that is a part of the location introduced by the elided PP *u kancelariju* (into the office). The PP that introduces a part of the original Goal is always a further specification of the Goal (makes it more precise), and therefore a kind of modification.

- (260) Jovan je u-bacio knjigu ~~u kancelariju~~, na sto.
 Jovan AUX in-threw book.ACC in office on desk
 ‘Jovan threw the book into the office, on the desk.’

This is as expected, since both the PPs modify the location, and the location introduced by one of them must therefore be part of the location introduced by the other (see Rothstein 2003 for a discussion of why this is the case). This construction has one important restriction. It is impossible for the PPs to have the opposite relation, in which the PP that fits the prefix (from now on the *prefix PP*) introduces a part of the other Goal PP. If the context is such that a container that is situated on the object of the preposition *na* (on) is suggested to be the object of the predicate *u-* (in), the resulting sentence is pragmatically very odd.

Take now for instance a context in which we are talking about throwing things in different boxes. A PP such as *u kutiju* (in the box) can then be elided (or topic-dropped) without affecting the acceptability of the sentence. In such a context, we might want to say that out of all the things to throw and all the boxes to throw them in, John threw a book and he threw it into the box which is on the desk. A sentence such as (261), which should be carrying such a meaning, is, however, unacceptable.

- (261) ??Jovan je u-bacio knjigu na sto, ~~u kutiju.~~
 Jovan AUX in-threw book.ACC on desk in box
 ‘Jovan threw the book into the office, on the desk.’

This points to an asymmetry. At least with respect to the surfacing word order, the PP related to the prefix must appear before the other PPs, and consequently the prefix PP must introduce the most general Goal, which is then made more specific by other Goal PPs.

Things now look better for the proposed analysis, at least with the type of prepositions discussed so far. The prefix always requires a proper prefix PP, and this PP must be the most direct argument of the predicate of the result phrase (the most general goal). Other PPs add to the information, make the statement more precise with respect to the Goal participant, and have properties of apposition and correction (observe the coma between the two PPs, which reflects a break in the intonation). A precise account of the structural representation of these constructions requires an elaborated theory of the syntax and semantics of appositional constituents and of correction and ellipsis, which goes far beyond the aims of this dissertation.

Let us now return to prefixes of the type of *iz-* (out), *od-* (from at) and *sa-* (from on). These prefixes all have one property in common. They belong to the so-called source prefixes, i.e. they are traditionally treated as modifying some property that appears at the beginning of an eventuality (see for instance Filip 2003). In terms of the present model, this means that they, and their corresponding PPs, are generated in the initiating subevent. Such a conclusion opposes the generalization that I started with, namely that all Slavic prefixes carry resultative meanings. However, as I show, the so-called source prefixes and PPs are in fact no less resultative than the others.

Observe the example in (262).

- (262) John drove the car away from the volcano.

This sentence contains a typical example of a source particle (*away*) and a corresponding source PP (*from the volcano*). The sentence indeed requires that the place introduced by the PP is the place at which the Undergoer (the car) was when the eventuality started. Although the car could have been at some distance from the volcano, it must still, in one way or another, be at a place describable as *at the volcano* in some relevant way, for instance within the reach of its lava and smoke.

However, the car can crucially not end up at the same distance from the volcano or at a place within some relevant area around the volcano in the given context. This means that the PP is not only contributing semantics to the initiating subevent, but also to the result subevent. The eventuality describes a situation in which John has made the car end up at a different place, which is further away from the volcano than the original one, or which does not fall within some relevant area around the volcano. Note that negation is used to describe the possible result states for the eventuality with respect to the so-called source prefix and the PP.

In any case, the eventuality in (262) is a proper telic one, and its result is that the car is out of some area which is considered as being close to the volcano. The same holds for S-C. All that the S-C sentence in (263) entails is that John pushed the trailer so that it ended up further away from the sprinkler than it used to be, or out of the reach of its water.

- (263) Jovan je od-gurao prikolicu od prskalice za vodu.
 Jovan AUX from_at-push trailer from sprinkler for water
 ‘Jovan pushed the car away from the sprinkler.’

The source phrase therefore introduces a participant that is certainly relevant for the predicate of the result subevent.

Recall now that in Chapter II section 3.6, I argued that every telic eventuality involves both a Source and a Goal participant. This is to say that every telic eventuality, in order to realize the template, requires some value for the affected property of the Undergoer in the initiating subevent, and another value for the same property and the same participant in the result subevent. The value in the initiating subevent is usually provided by the context, it is topicalized, and therefore often remains without overt realization (due to the ellipsis being licensed by topicality). This is less frequently the case with the value of the Goal: this value is usually new to the discourse, and the Goal is therefore more often overtly specified. Translated to the given situation, this means that the so-called source prefixes and PPs are able to assign values in both the initiating and the result subevent.

If we combine this last observation with the fact that negation had to be used to describe the result state of the Undergoer in an eventuality modified by a ‘source’ prefix and a ‘source’ PP, we come to an intuitive solution for the problem, coming directly from the definition of the telic template. The so-called source modifiers are in fact introducing a certain value for the relevant property of the Undergoer in the initiating subevent and the negation of that value for the same property of the same participant in the result subevent. This is represented in (264): the Goal is the algebraic complement of the Source. For reasons of space, I refrain from going into the syntactic representation of the Source.

- (264) ‘Source’ modifiers: the goal is the algebraic complement of the source

Jovan je iz-bacio psa iz sobe.
 Jovan AUX out-threw dog.ACC from room.GEN
 ‘Jovan threw the dog out of the room.’

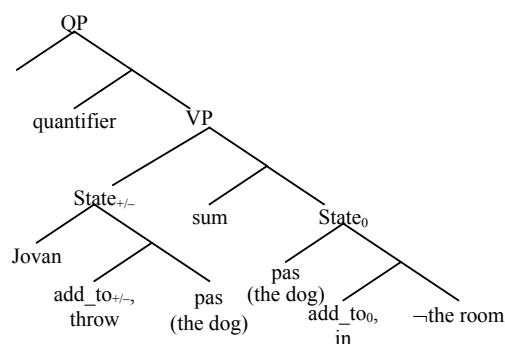

The Goal involving negation in the tree in (264) behaves exactly as any other direct Goal: it is a prefix PP, suiting the meaning of the prefix. Moreover, any additional specification for the Goal must introduce a location which forms part of the location denoted by the negation of the direct Goal. In the given case, any further goal must

fall within the complement of the space taken by the room. Therefore, as (265) shows, the box is entailed as not being within the room. This guarantees that the template is realized in the part related to having different values for one and the same property of the Undergoer: the negation encodes the difference.

- (265) Jovan je iz-bacio^P psa iz sobe u kutiju,
 Jovan AUX out-threw dog.ACC out room.GEN in box
 #koja se nalazila usred te iste sobe.
 which REFL be_placed in_middle that.GEN same room
 ‘Jovan threw the dog out of the room, into the box, which was placed in the very room.’

The conclusion is therefore that, although so-called source modifiers indeed modify the Source, they also assign a direct value to the Goal. It is the predicate of this value that is reflected in the prefix on the verb. The particular properties of these modifiers are that they overtly specify the Source and that they involve negation in the specification of the Goal. Asymmetries in the behavior of the so-called Source and Goal modifiers, such as those presented in Gehrke (2005b) and in Filip (2003), are therefore due to one of these two different properties of this class of elements.

Therefore, neither the fact that Goals can be doubled, nor the possible asymmetries in the behavior of the Source and Goal modifiers present a problem for the present approach, or in general for any analysis of Slavic verb prefixes as reflexes of the result subevent predicates.

A more general conclusion of the subsection is that Slavic prefixes do reflect telicity, but are not markers of telicity. They represent predicates of the result subevent in the telic template, which means that they can only be generated in the telic template. Their presence therefore indicates the presence of the telic template in the structure of the eventuality. They are not, however, lexicalisations of the head that derives the telic template: they are generated within one of the arguments of the predicate *sum* that projects the telic template.

2.2. The imperfective suffix

The analysis of the Slavic verb prefixes that is presented in the preceding subsection treats verb prefixes as predicates of the result subevent. Every eventuality described with a prefixed verb therefore involves a telic template. As illustrated in (252), repeated as (266), a prefixed verb (or a stem verb which is perfective) in S-C can take the secondary imperfective suffix *-va* (‘secondary’ relates to the imperfective nature, because verbs taking this suffix often also have imperfective meanings in their stem forms).

- (266) a. Jovan je gur-ao^I kolica.
 Jovan AUX push-PTC cart
 ‘Jovan was pushing the cart.’
 b. Jovan je od-gur-ao^P kolica.
 Jovan AUX away-push-PTC cart
 ‘Jovan pushed the cart away.’

- c. Jovan je od-gura-va-o^I kolica.
 Jovan AUX away-push-I_suff-PTC cart
 ‘Jovan was pushing the cart away.’
- d. Jovan je iz-od-gura-va-o^P kolica.
 Jovan AUX out-away-push-I_suff-PTC cart
 ‘Jovan completed the/some eventuality of pushing (the) carts away.’

This, in traditional terms, makes the verb imperfective. The direct effect is that the singular reading of the telic eventuality is excluded, and the initiating subevent of the same eventuality is made prominent. These effects are very similar to, or even identical with, the effects of the English progressive. That the imperfective suffix *-va* in Slavic languages corresponds to the English progressive has already been argued by Borer (2005b). Apart from the fact that they share interpretational effects and other arguments put forth by Borer, there is one important property common to the two forms that is correctly predicted by the present model.

I showed in Chapter IV, subsection 3.4 that the progressive only applies to telic eventualities, and that when applied to those with a preferred atelic reading, it imposes on them a telic structure. Since in S-C telicity is always reflected on the verb (whether morphologically or lexically), this predicts that the verbs that clearly do not describe a telic eventuality will not be able to take the imperfective suffix. This is indeed confirmed in (267).

- (267) *Jovan je hoda-va-o pored Dunava.
 Jovan AUX walk-va-ed by Danube
 intended: ‘Jovan was walking along the Danube.’

If a speaker is forced to interpret this ungrammatical sentence, the reading would be iterative, over some contextually bounded eventuality of walking along the Danube. This is the bare plural reading, but not over a proper telic eventuality – rather, it takes a stative eventuality that is temporally bounded and can therefore form a mass division. No singular reading is available, since no result component can be imposed on this eventuality. The result component is blocked by the fact that its absence is morphologically marked.

Let us now see how the progressive structure represents the suffix *-va*. This is shown in (268): the suffix introduces the progressive template and is generated in the stative head that denotes the intersection between one dynamic atelic and one telic eventuality. The suffix, therefore, marks that the telic eventuality intersects with an unspecified action.

- (268) Structure that generates the imperfective suffix *-va*
 Jovan je od-gura-va-o^I kolica.
 Jovan AUX away-push-I_suff-PTC cart

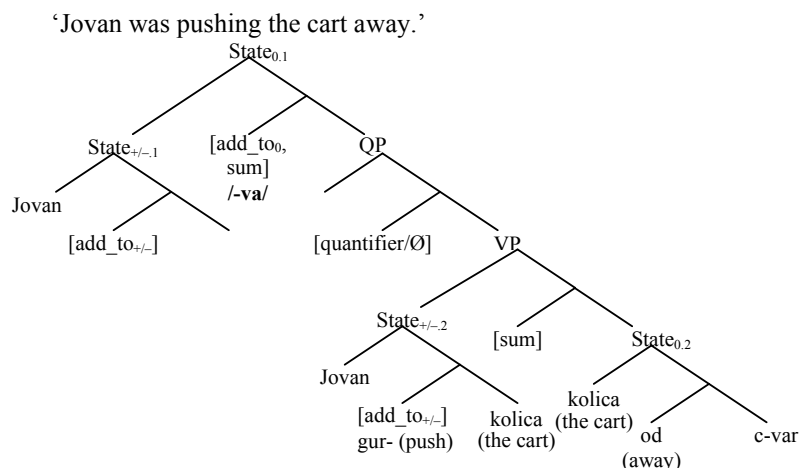

There is one final parallel between the progressive and eventualities involving a secondary imperfective in their description. Whenever the meaning of an eventuality that is specified for termination has a description with an imperfective verb, the meaning of the sentence displays imperfective paradox effects. Observe (269).

- (269) Jovan je u-gur-av-ao¹ kolica u prodavnicu kada ga
 Jovan AUX in-push-I_suff-PTC cart in shop when him
 je ubio grom.
 AUX killed thunder
 ‘Jovan was pushing the cart into the shop when the thunder killed him.’

The telic eventuality of John pushing the cart into the shop has not occurred: it was interrupted before completion. Nevertheless, it is used to describe a certain situation without any modal embedding. This fully parallels the cases of imperfective paradox discussed in the Chapter IV, section 3.4.

I therefore simply extend the application of the progressive structure to cover the phenomenon of imperfectivity in Slavic languages.

2.3. External (or superlexical) prefixes

In all Slavic languages, verb prefixes seem to undergo a certain division that involves a number of properties. This division is treated in the works of DiSciullo and Slabakova (2005), who distinguish between the internal and the external prefixes and in Svenonius (2004), who calls one class lexical and the other superlexical prefixes. Although there are some differences in the classes to which some particular prefixes are argued to belong according to these approaches, I assume that they target the same division and I use the terms *internal* and *external* in order to avoid a discussion of the effects that prefixes have on the lexical meaning of the verb.

I have already introduced some differences between the two classes of prefixes. One of them is that internal prefixes attach to stem verbs only. External prefixes however can be attached to verbs that already have one or more prefixes (they can ‘stack up’), usually in addition to the imperfective suffix *-va*. Another is that verbs that only have an internal prefix become imperfective when the suffix *-va* is added,

and verbs that have external prefixes are perfective irrespective of the presence of the imperfective suffix. These properties are illustrated in the paradigmatic example that I repeat here again as (270).

- (270) a. Jovan je gur-ao^I kolica.
 Jovan AUX push-PTC cart
 ‘Jovan was pushing the cart.’
 b. Jovan je od-gur-ao^P kolica.
 Jovan AUX away-push-PTC cart
 ‘Jovan pushed the cart away.’
 c. Jovan je od-gura-va-o^I kolica.
 Jovan AUX away-push-I_suff-PTC cart
 ‘Jovan was pushing the cart away.’
 d. Jovan je iz-od-gura-va-o^P kolica.
 Jovan AUX out-away-push-I_suff-PTC cart
 ‘Jovan completed the/some eventuality of pushing (the) carts away.’

Since the imperfective suffix is traditionally viewed as some kind of imperfective operator which operates over the VP, this asymmetry is often formulated in terms of scope. The imperfective suffix is taken to scope over the internal prefixes, but to be outscoped by the external prefixes. This is where the terms *internal* and *external* originate: prefixes can be out of or within the scope of the suffix. Note that this requires not only for the imperfective suffix to be an operator, but at least for the external prefixes to be operators too.

A further interesting difference is that internal prefixes often can cause a shift in the meaning of the lexical verb, as illustrated in (271a), while external prefixes tend to simply modify the derived meaning of the eventuality with respect to quantity, as in (271b). This is where the terms lexical and super-lexical come from: lexical prefixes are generated within the domain that still directly relates to the lexical meaning of the verb, while super-lexical prefixes are generated higher than this domain.

- (271) a. biti u-biti raz-biti pro-biti od-biti do-biti
 beat in-beat around-beat through-beat away-beat to-beat
 ‘beat’ ‘kill’ ‘break’ ‘make a hole in’ ‘bounce’ ‘get’
 b. kuvati na-kuvati iz-kuvati pro-kuvati pre-kuvati
 cook on-cook out-cook through-cook over-cook
 ‘cook’ ‘cook many’ ‘cook all/fully’ ‘cook a bit’ ‘overcook’

Ergo, the capacity to change the lexical meaning of the verb is related to the position in which the prefix is generated. Prefixes can only change the meaning of the verb if they occur within a structure in which this meaning is derived, as stated in (272).

(272) All verb-prefixes in S-C form one lexical class and are generated in the telic template, by the same mechanism. Internal, or lexical, prefixes are those generated in the most deeply embedded telic template in the structure, in which also the verbal stem is generated, and in which the lexical meaning of the verb is determined.

In syntax, the way the asymmetry between the internal and the external prefixes is usually accounted for is by deriving the internal prefixes in the domain of the

traditional VP and the external ones in an aspectual or quantificational projection outside of this domain. Svenonius (2004) proposes the structure in (273).

(273) Derivation of the Slavic verb-affix system by Svenonius (2004)

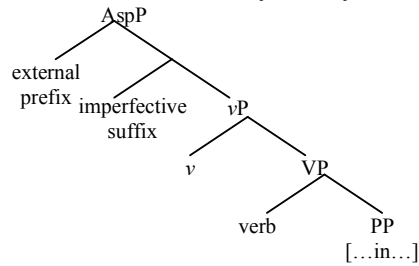

In this structure, the internal (for Svenonius: lexical) prefixes are derived deep inside the VP, in the core of the lexical domain. They introduce participants to the eventuality, which is traditionally seen as one of the domains that is most closely related to the lexical meaning of the verb. The external prefix is derived in the specifier of the aspectual phrase (AspP). This is the same phrase that generates the imperfective suffix, except that the suffix is generated in the head of this phrase. Prefixes introduce perfectivity and the suffix introduces imperfectivity. Their scopal relations determine which meaning wins when more than two of them are present: the external prefix ‘wins from’ the suffix and the suffix ‘wins from’ the internal prefix.

Another recent approach is that of Di Sciullo & Slabakova (2005). They explicitly relate both internal and external prefixes to terminativity, and introduce two positions in which terminativity can be marked, one inside and the other outside the VP. If terminativity is marked by a prefix within the VP, it will derive an internal prefix, and if it is marked in the same way, but outside the VP, it will derive an external prefix. This paper represents terminativity as a quantificational notion, parallel to the nominal quantification. Part of the parallel lies in the fact that external terminativity is related to a level that corresponds to determiners in the nominal system, which is tense in their approach. Terminativity is therefore viewed as a quantificational predicate, marked as [T] in the illustration in (276). One of its instances is generated in the vP (roughly the highest projection within the domain of the verb phrase), while the other is generated in the TP (with tense).

(274) Derivation of Slavic prefixes in Di Sciullo & Slabakova (2005)

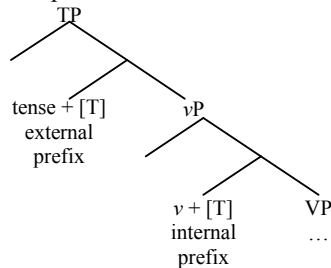

There is one controversy concerning both these views, and other similar ones. On the one hand, external prefixes really do resemble operators: they correlate with

certain quantificational aspects of the eventuality. This makes them similar to imperfective marking. On the other hand, there is a strong asymmetry between these two elements, namely that one of them surfaces as a prefix and the other as a suffix. Finally, there is a strong similarity between external prefixes and internal ones: most or all morphemes which appear as external prefixes can also appear as internal ones. Hardly any morpheme that appears as an external prefix is not also found in the position of internal prefixes.

Di Sciullo & Slabakova's approach does in fact capture the similar nature of the two types of prefixes, but the cost of this move is their claim that all prefixes are pure operators, and therefore also functional elements. This is empirically very difficult to defend, since, as already shown in this section, prefixes strongly correspond to certain prepositions and contribute lexical meanings.

Finally, in the present model, even the meaning of the imperfective suffix *-va* is not seen as an operator, but as introducing a particular structure that relates two eventualities. Scope between operators therefore becomes even less suitable for describing the system of verb affixation in Slavic languages.

In this subsection, I present a different account of external prefixes, including their similarities with and differences from the imperfective suffix and internal prefixes. I show how external prefixes can be generated as lexicalizations of resultative heads just as the internal ones. The only difference is that external prefixes represent predicates that take eventualities instead of nominal expressions as their arguments.

Observe the sentences in (275).

- (275) a. Jovan je iz-od-gura-va-o^P kolica.
 Jovan AUX out-away-push-I_suff-PTC cart
 'Jovan pushed carts away to the exhaustion of the presupposed quantity of this eventuality.'
- b. Jovan je na-u-baci-va-o^P knjige u orman.
 Jovan AUX on-in-throw-I_suff-PTC books in cupboard
 'Jovan did a lot of throwing the books into the cupboard.'

The English translations result from trying to faithfully reproduce the intuition about the meaning of these sentences. The underlined expressions in these translations correspond to the (also underlined) external prefixes in the examples. In the example in (275b), there must be a definite amount of books, and all of them must end up in the cupboard.

In both examples, there is a strong parallel between the literal meaning of the external prefix and the part of the translation that relates to it. The meaning of exhaustion is directly related to the prefix *iz-* (*out*), and the meaning of a large quantity can be derived by piling up units of some matter one on another, and thus to the prefix *na-* (*on*). In fact, the meaning of the first sentence can be represented as taking a context which determines some aggregate available set of instances of the eventuality of pushing a cart away and entailing that one by one instance of the eventuality from the contextually available set is pursued until the set is exhausted. The meaning of the second sentence can similarly be seen as pursuing, one after another, instances of the eventuality of throwing one of the books into the cupboard, until a large 'pile' of the instances is formed in our conceptual representation.

A formal representation along these lines is given in (276).

(276) Representation of the external prefix in (275a)

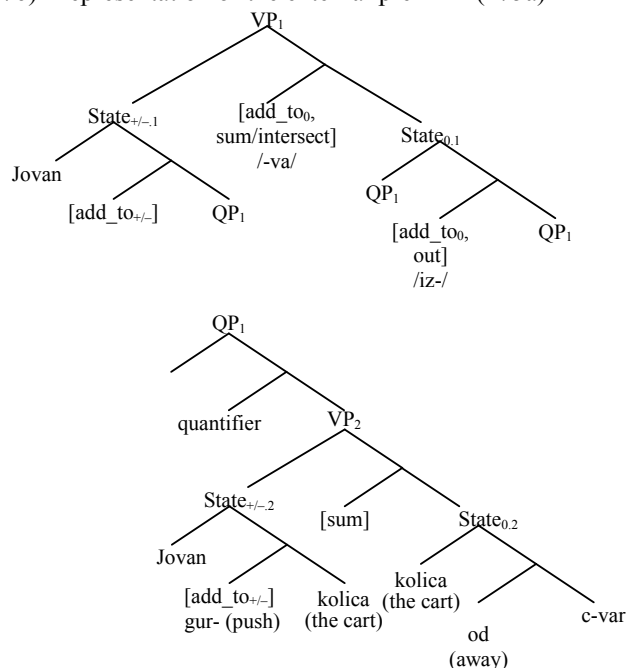

This is similar to the representation of the progressive: there is a phrase that specifies a light predicate taking two eventualities as its arguments. Furthermore, the eventuality in the specifier is a process, while the one in the complement involves a telic template. There are, however, three crucial differences.

One is that the structure that is derived (VP_1) cannot be interpreted as a stative eventuality, but only as a telic one. In other words, the light predicate here cannot receive the interpretation of intersection, and this forces us to interpret it as a sum. This is due to the fact that the complement of the quantity of the argument in the specifier of the VP_1 is assigned a different value in the specifier of the complement of the VP_1 . This makes it a proper Undergoer, and assigns the telic interpretation to the aggregate structure. The two other differences are closely related to this one.

The second difference is that the process in the specifier of the VP_1 has a specified complement, and that this complement is the same quantified telic eventuality (QP_1) that appears in the result state of the VP_1 .

The third is that the quantified telic template (QP_1 , the full structure of which is given in the separate structure) is not a direct argument of the predicate *sum/intersect* of the larger structure (the head of the VP_1). The direct argument of this predicate is a state ($State_{0,1}$), which is headed by the lexical predicate *iz-* (out), and it takes the quantified telic eventuality QP both in the specifier and in the complement position.

The meaning that is derived in the state headed by the external prefix ($State_{0,1}$) is that the (presupposed) quantity of the telic eventuality of pushing the cart to the shop

is exhausted: the quantity of the eventuality is specified as being ‘out of itself’. In the VP₁, this state of exhaustion is interpreted as the result, since the structure derives a concatenation between this state and the process in the specifier of the VP₁.

Altogether, an action is pursued by Jovan with respect to the quantified eventuality of Jovan pushing the cart to the shop, and its result is that the quantity of this eventuality is exhausted.

In this view, external prefixes lexicalize the same predicates as internal ones. The difference is that a) external prefixes take eventualities and not nominal expressions as their arguments and b) the specifier and the complement of an external prefix have to be coreferential. How different spatial relations in the result subevent receive quantitative interpretation is discussed in detail in Arsenijević (to appear, c).

This account derives all the major properties of the two classes of prefixes. External prefixes appear to neutralize the effects of the imperfective suffix *-va* simply because they force a telic interpretation on the phrase headed by the suffix, (or else there would be no result subevent, i.e. no position to derive the prefix). This requires a different semantic definition of the suffix: it lexicalizes a light head, by default interpreted as *intersect*. However, as argued in section 3.3, page 186, when heading the telic template, the light, unspecified head is forced the sum interpretation.

External prefixes do not modify the lexical meaning of the verb because they are generated at a level that takes eventualities as arguments. As already argued in this and the previous subsection, the so-called lexical meaning of the verb is always frozen at the level of the most deeply embedded VP.

The quantificational meanings of external prefixes result from the fact that they take the same referent in their specifier and in their complement position. This is a way to specify quantification over eventualities without any lexical units reserved to lexicalize quantifiers over eventualities. Having a certain quantity ‘on itself’ gives a large quantity, having it ‘out of itself’ or ‘from itself’ gives exhaustion, having it ‘to itself’ gives completion etc.

Every prefix that is derived at a level that embeds an eventuality will be external. Internal prefixes are derived only in the most deeply embedded eventuality, i.e. they take must take nominal and not verbal arguments. This is why only the prefix closest to the verb can be internal, while all the others will be external. This leads to a stacking of external prefixes. For the rest, external prefixes are just like the internal ones, and that is why they have the same lexical realization.

The structure introduced for external prefixes slightly changes our view of the imperfective suffix *-va*. This suffix is not exclusively the head of the progressive structure, but more generally of a structure with a light predicate (*sum/intersect*) and eventualities in the argument positions. Similarities between the external prefixes and the imperfective suffix can be captured by the fact that both require the arguments of some predicate in the description of an eventuality to be eventualities rather than nominal expressions.

2.4. The semelfactive suffix

One final case that provides support for the analysis presented here is that of the semelfactive suffix *-n(u)* and its imperfective variant *-ka/-ta*. The suffix *-nu* is generally present in the aspectual systems of all Slavic languages, and it has already been described and discussed (e.g. Jablónska 2004). Its imperfective version *-ka/-ta*

appears, to my knowledge, to be more or less restricted to S-C and some dialects of other Slavic languages.

Semelfactivity is a property of eventualities, related to their temporal interval (see Smith 1991 for an extensive discussion). An eventuality is semelfactive if its temporal interval takes only one point in time. There are lexical verbs that are usually associated with semelfactive interpretations, as in (277a), but there are also other, lexical (277b) and functional (277c) means of marking semelfactivity on the VP.

- (277) a. John blinked.
 b. John suddenly got red.
 c. Jovan je vris-nu-o^P.
 Jovan AUX scream-NU-PTC
 ‘Jovan screamed in a point in time.’

The semelfactive suffix *-nu* (henceforth *S_{diff}* in the glosses) has very straightforward effects: it assigns the eventuality a punctual temporal interval. Naturally, this also makes the verb perfective, and assigns a non-homogeneous value to the inner aspect of the eventuality. This is illustrated in (278), where two different verbs show the change in meaning caused by this suffix.

- (278) a. Jovan je griz-ao^I jabuku.
 Jovan AUX bite-PTC apple
 ‘Jovan was biting an apple’
 b. Jovan je griz-nu-o^P jabuku.
 Jovan AUX bite-S_{diff}-PTC apple
 ‘Jovan bit (a little) at an apple’
 c. Jovan je pliv-ao^I.
 Jovan AUX swim-PTC
 ‘Jovan was swimming’
 d. Jovan je pliv-nu-o^P.
 Jovan AUX swim-S_{diff}-PTC
 ‘Jovan swam for a moment’

At first sight, this suffix seems to display the opposite pattern from the imperfective suffix: it can only appear on imperfective verbs (with some exceptions) and when it does, it derives a perfective verb. In addition, the two suffixes do not occur together. This is why different accounts of Slavic aspect generate these two suffixes in the same head (for instance Jabłńska 2004).

This presents a problem for the present approach: the progressive structure proposed for the imperfective suffix would require much force to derive semelfactive meanings. If the structure introduced by the imperfective suffix is used to describe a process as part of a telic eventuality (just like the progressive), what is the opposite interpretation of this structure that would result in a semelfactive interpretation?

In fact, there are some good arguments for assuming that these two suffixes are not of the same kind, and that they are derived in different projections. First of all, in S-C the meaning of the suffix *-nu* is not just semelfactive (as obvious already from (278a)). This is different for the suffix *-va*, which always has exactly the same aspectual effects. Observe the examples in (279).

- (279) a. Jovan je pec-nu-o^P paprike.
 Jovan AUX bake-S_suff-PTC paprika's
 'Jovan baked the paprika's a little.'
 b. %Jovan je trk-nu-o^P par krugova oko stadiona.
 Jovan AUX run-S_suff-PTC couple laps around court
 'Jovan ran a couple laps around the court (and he normally runs more).'

In these two sentences, the eventualities described by the verb that takes the suffix are not really semelfactive. They may both take a longer period of time. The contribution of the suffix seems to be in introducing to the interpretation of the eventuality some bounded quantity, which is a relatively small part of a larger quantity of the same eventuality.

A further argument is that the so-called semelfactive suffix is much more restricted in productivity. There are a large number of verbs which do not combine with this prefix, such as the very frequent verbs in (280).

- (280) a. * Jovan je hod-nu-o.
 Jovan AUX walk-S_suff-PTC
 b. * Jovan je jed-nu-o jabuku.
 Jovan AUX eat-S_suff-PTC apple

There is no such restriction on the imperfective suffix: every perfective verb has an imperfective form. Only a limited number of verbs have a different allomorph used for this purpose, but even in these cases, the imperfective semantic contribution can be added to the meaning of any perfective verb through the same structure.

A final and crucial argument against deriving the two suffixes in the same head is the fact that their meanings are not mutually exclusive. In fact, S-C has the suffix *-ka*, which represents a combination of the two meanings. This suffix, which I call the *combined suffix* (CMP_suff in glosses), is illustrated in (281).

- (281) a. Jovan je pec-ka-o^I paprike.
 Jovan AUX bake-C_suff-PTC paprika's
 'Jovan was baking (the) paprika's a little.'
 b. Jovan je trč-ka-o^I par krugova oko stadiona.
 Jovan AUX run-C_suff-PTC couple laps around court
 'Jovan was running a couple laps around the court (with low intensity).'

Recall that one of the arguments in favor of deriving the two suffixes in one head was that they are mutually exclusive. While indeed the two morphemes never appear together, their meanings in fact can combine, and this combination can be lexicalized in S-C by a third suffix. So far, it is still possible that the two predicates that are lexicalized by two different suffixes are generated in the same head, and that in that case a different morpheme is used for their lexicalization.

However, the meaning that is derived in this way is always the one that corresponds to the imperfective suffix. The verb is imperfective and the sentence can be translated with the progressive. This means that, in the hierarchical structure of the sentence, the imperfective suffix must be generated higher than the so-called semelfactive one, i.e. they cannot be in the same position.

We know now not only that the two suffixes are not generated in the same head, but also that the semantic component of the suffix *-nu* must be generated lower than the position of the suffix *-va*. In the proposed structure, this means that the former suffix is derived within the QP, since this is the only material lower than the imperfective suffix. This is shown in (282).

(282) Possible positions for the generation of the suffix *-nu*

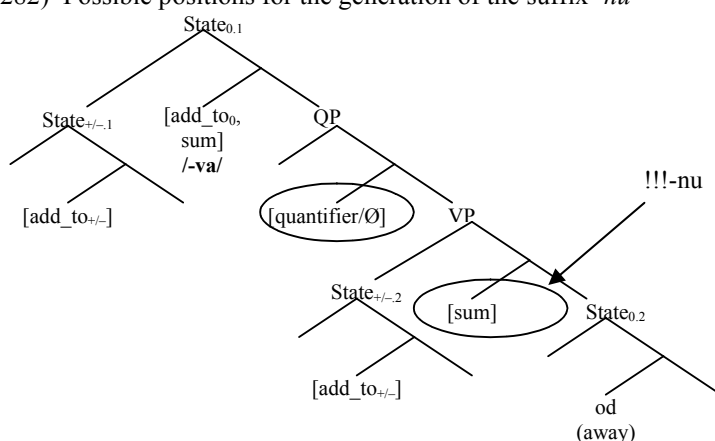

It is clear that the heads of the subevents in the telic structure are not good candidates since the suffix never contributes any resultative or process-related meaning. The only two candidates are the QP and the VP. In either case, the suffix lexicalizes a functional head from the projection of an eventuality.

Closing the discussion, let me present some arguments to show that the right position to derive this suffix is the head of the VP, and that the suffix marks the presence of a telic template in cases where the description of the eventuality does not define one.

The semantic effects of the suffix *-nu* are shown above to vary between marking that an eventuality takes an atomic temporal interval and marking that a certain part of some possibly larger quantity of an eventuality has taken place.

This is compatible with the proposed interpretation of the predicate of division. The atomic temporal interval appears as the natural interpretation when the description of an eventuality does not provide any unit of division, but division must still be applied. The natural solution is to take the atomic temporal interval as corresponding to the smallest possible quantity of the eventuality. The atomic interval also provides a partitive interpretation, when related to the mass from which it selects a unit.

A further argument in favor of the proposed analysis is that the combination of the semelfactive suffix with an eventuality that is marked as telic by other means, such as an internal prefix, is ungrammatical in S-C, as the examples in (283) illustrate. A verb cannot have an internal prefix and a semelfactive suffix at the same time (external prefixes are irrelevant since they are generated in a different eventuality).

(283) a. *Jovan je u-griz-nu-o^P mnogo jabuka.
 Jovan AUX in-bite-S_suff-PTC many apples.GEN

- b. *Jovan je za-pec-ka-o^l paprike.
 Jovan AUX bake-C_suff-PTC paprika's

This is in fact predicted by the proposed analysis: the suffix is argued to appear only when the predicate of the eventuality fails to define the unit of counting and a countable interpretation must be derived. As explained in 2.1, the prefix is generated in the result subevent of an eventuality, and signals that the eventuality specifies a concatenation and defines the minimal unit. Marking by the suffix is then redundant.

The atomic nature of the temporal interval and the quantity of the eventuality that it selects is relative and determined by the context. Observe for instance the following situation. The conversation is about the Danube and its shape around Belgrade over the last 3000 years. The shortest process that has been discussed so far took ten years. At this point, the speaker wants to describe a change that took only several months. In this context, it is fully natural to use the sentence in (284).

- (284) Tada se Dunav su-nu-o^p dvadeset kilometara ulevo.
 thenREFL Danube pour-S_suff-PTC twenty kilometres to_the_left
 'Then the Danube turned twenty kilometres to the left.'

It is really perceived that the time taken by the turn that the Danube made is atomic in the given context. This is a consequence of the fact that the interval that it takes must be smaller than the one perceived as the smallest available one, namely ten years in the given case.

A possible test for this view on the suffix *-nu* is to observe examples in which the QP is filled, and reflected on a nonspecific argument. As I have presented in Chapters III and IV, if there is a non-quantified nonspecific argument in an eventuality, it will be bound by the quantifier over that eventuality. In such a case, the quantifier is reflected on the argument as a nominal quantifier. This is illustrated in (285a).

- (285) a. John ate many apples. (many instances of Jovan eating a nonspecific apple)
 b. Jovan je griz-nu-o^p mnogo jabuka.
 Jovan AUX bite-S_suff-PTC many apples.GEN
 'Jovan bit just a little at many apples' (many instances of Jovan biting a little at an apple)

Observe however (285b). There are, as required, many eventualities of biting a little into an apple. Whatever the contribution of the suffix, it cannot be the one of quantification since in that case the two quantifiers would clash.

Recall now that the suffix *-nu* is shown to have a restricted productivity. This was exemplified in (280), repeated in (286).

- (286) a. *Jovan je hod-nu-o.
 Jovan AUX walk-SMF_suff-PTC
 b. *Jovan je jed-nu-o jabuku.
 Jovan AUX eat-SMF_suff-PTC apple

I have just argued that *-nu* marks a division into atomic units for the relevant eventuality. For the two eventualities in the example, there are two pragmatically very prominent units of division, which are available in any context. For walking,

this is making one step, and for eating, it is taking one bite or making one ‘chew’. Both these meanings have separate lexical realizations in S-C, as in (287).

- (287) a. Jovan je korak-nu-o.
 Jovan AUX step-S-suff-PTC
 ‘Jovan made a step.’
 b. Jovan je griz-nu-o jabuku.
 Jovan AUX bite-S_suff-PTC apple
 ‘Jovan bit at an apple.’

Therefore, the unavailability of the suffix *-nu* with these verbs can be explained through pragmatics and the elsewhere effect. Firstly, the atomic units of the relevant predicates are always imposed by the context, and secondly, these units trigger realization by some other lexical units.

3. Conclusion

In this chapter, I showed how the proposed model can capture the facts of the system of verb affixes in Slavic languages, more precisely that of Serbo-Croatian. This system is particularly interesting due to its overt marking of the aspectual properties of the eventuality. Three types of morpho-syntactic units that are uses, the suffixes, the internal prefixes and the external prefixes, are presented in this chapter and then discussed in light of the present model.

Following the views of Žaucer (2002), Gehrke (2005a, b) and Arsenijević (to appear, a), I proposed to generate the internal prefixes in the head of the result subevent of the telic template. These prefixes are therefore argued to lexicalize (parts of) the predicate of the result subevent, and necessarily require a telic eventuality to be generated.

With respect to the imperfective suffix *-va*, I followed to some extent Borer (2005b) in viewing it as a counterpart of the English progressive. I provided some additional arguments for this view, but also showed that the meaning of the Slavic imperfective suffix is slightly more general than that of the progressive. Based on this parallel, I used the structure already proposed for the progressive to derive the Slavic suffix *-va*. This suffix was argued to introduce a structure in which the arguments of the predicate *sum/intersect* are not nominal expressions but eventualities.

I further argued that external prefixes are generated in more or less the same way as internal ones. The main difference is that external prefixes take eventualities, and not nominal expressions, as their arguments, but also that they require their specifiers to corefer with their complements. This derives a quantificational interpretation, since the result of the eventuality is defined in terms of a relation of a certain quantity with itself (A on A, A over A, A out of A etc.).

Finally, I argued that the so-called semelfactive suffix, i.e. the suffix *-nu*, at least in Serbo-Croatian, is not of the same type as the imperfective suffix. I argued that the suffix *-nu* is a lexicalization of the head of the VP in eventualities without a defined unit of division (eventualities without concatenation). As part of this argument, I presented some new data about the Serbian suffix *-ka*, which lexicalizes a combination of the meanings of the two other suffixes *-nu* and *-va*.

Chapter VI: Conclusions and perspectives

1. Overview

This dissertation offers a general overview of the problems related to the semantics and syntax of the VP, it presents and discusses four different approaches to this domain and proposes a new model, which is argued to have important advantages and to unify dimensions that are often viewed as standing in opposition to each other.

The first two chapters of the dissertation establish the relevant background. In Chapter I, I gradually introduced the most relevant notions related to eventualities and the syntax and semantics of the VP. Central among them are argument structure, patterns of decomposition, inner aspect and the mutual relations of these three phenomena. A simple model of structural representation is sketched, which is derived as a hybrid from those available in the literature.

This chapter opened questions that were treated throughout the rest of the dissertation. Some of the most important ones are: to what extent must eventualities be accounted for in semantic and to what extent in syntactic terms? What is the role of pragmatics in this domain? Is grammar sensitive to elements used in ontological decompositions of eventualities? And is it possible to derive participant roles from aspectual properties?

Different answers to these questions have different consequences for the field of NLG. I point out the advantages of the models of the VP that involve decomposition, especially in the domain of inferencing. Having the structure of a telic eventuality transparently built from processes and states provides an explicit link between the complex units and their components and allows for accessing both in the process of inferencing. This supplies inferencing with more material to work with. At the same time, it also provides explicit representations of relations between certain meanings, which would otherwise have to be stipulated in the inferencing machine (such as the fact that a certain state is entailed to hold at the end of a certain telic eventuality).

Chapter II concentrates on inner aspect and its relations with the properties of different participants and predicates involved in the eventuality. It presents four different approaches to this problem: Verkuyl (1972, 1993), Krifka (1992, 1998), Borer (2005b) and Ramchand (2002).

Verkuyl combines syntax, semantics and lexical information in order to account for telicity. His theory does not involve patterns of decomposition, but relies rather on the quantificational and lexical properties of the building elements of the VP.

Krifka goes even further in trying to derive inner aspect from quantificational, or in his terms mereological, notions. Even meanings such as Goals and Sources, or initial and final parts of eventualities are defined in his model in terms of simple algebraic tools and part-whole relations. Krifka provides a radically semantic account, but he still to some extent relies on the lexical meanings of verbs. He does not discuss any syntactic aspects of the domain.

With respect to this last point, Borer's theory takes an inverse approach. Inner aspect is more or less entirely derived in syntax, from syntactic relations between the heads that mark the relevant semantic properties and their arguments. Borer proposes a theory without any elements of decomposition: it only operates with a

small number of mereological notions, which she argues have the syntactic status of functional elements.

Ramchand's account is strongly decompositional and proposes a pattern consisting of three subevents: the initiating subevent, the process, and the result. She argues that quantificational and mereological effects which are not directly derived from the pattern of decomposition are external to the domain of event structure. She sees them as effects of a number of more general relations between quantifiers, such as scope and distributivity. Ramchand's account is strongly syntactic. It assigns a strict structural representation to the pattern of decomposition that she proposes for eventualities and captures most empirical generalizations in terms of the properties of this syntactic structure.

Each of the four approaches received a thorough discussion in the context of the aims of the dissertation. These discussions all share some common points. First, they observe the disadvantages of excluding from the theory any member of the two oppositions, i.e. quantification or decomposition, syntax or semantics. Second, they point to concrete problems in each of the models. For instance, I show that with respect to the class of VPs in which the inner aspect of a dynamic eventuality does not (always) show effects of the properties of the direct object, the accounts proposed by Verkuyl, Krifka and Borer all suffer from serious problems. Finally, at many points, the discussions relate concrete problems and the ways they are accounted for with more general questions concerning the theory of grammar. For instance, one such question is posed by the discussion of the mereological properties, which tackles the question of the combinations of mereological properties that can be found in natural language, and how these properties relate to entailment and quantification.

In Chapter III, I presented a new model of the syntax and semantics of the VP. The model recognizes simple and complex eventualities, where simple eventualities correspond to processes and states and the complex ones to telic eventualities. Telic eventualities are built in a template that asymmetrically concatenates one process and one state. Simple eventualities are defined as predications based on the predicate *add_to*. The meaning of this predicate involves a function that maps from time to properties. This predicate appears in two relevant flavors, as *add_to_{+/-}*, giving rise to dynamic interpretations, i.e. processes, and as *add_to₀*, giving rise to stative interpretations, i.e. narrow states. The former involves a linear monotone increasing or decreasing function, i.e. a one-to-one mapping, while the latter involves a constant function, i.e. an all-to-one.

States undergo two basic operations: intersection and sum, leading in both cases to more complex predications. If the two eventualities do not share any temporal interval, the sum operation will concatenate them. One interesting case in which the sum of two simple eventualities results in concatenation is when they assign mutually excluding properties to one and the same argument. I argued that a concatenation of this type derives a telic eventuality.

This concatenation is asymmetric, which means that its two subevents (the two simple eventualities) have a certain ordering. In the aggregate interpretation, the earlier of the two subevents is interpreted as the initiating component and the one that comes later as the result. This pattern, to which I referred as the telic template, forces a process (*add_to_{+/-}*) interpretation onto the initiating subevent and a stative

(*add to*) interpretation for the result subevent. More formally, there is a value within the co-domain of the monotone function involved in the process, which corresponds to a certain property, and which is directly linked with the state that appears as the result subevent. The aggregate interpretation of the telic template thus has two important components. One is that the predicate of the initiating subevent and the predicate of the result subevent hold in two adjacent temporal intervals. The other is that the predicate of the result subevent is directly linked to the value of the monotone function of the process at the end of the initiating subevent. Concatenations in which the first member is a state are out because a state involves a constant function, so it is not possible to single out any value at the end of this subevent that is linked with the predicate of the result. In other words, a stative eventuality does not manage to initiate a transition to the result state. A process cannot appear as the second member of the concatenation because a single value of the function involved in the initiating subevent (i.e. one single property) is linked only with one value in the result subevent. If this value is just the starting segment of a process, only the segment with this value will nevertheless count as the result subevent and the other values will not be part of the telic template.

In this model of decomposition, the telic template has the crucial property of defining the canonical singular. Predicates defining a canonical singular are countable and can be quantified by a wide variety of quantifiers, which further enables them to be related with the reference time. This makes the telic template special in the domain of meanings that establish reference through temporal intervals. The link between the telic template and countability directly links decompositional aspects of eventuality with the quantificational and mereological ones. This makes the telic template parallel to grammatical number in the nominal domain: a non-quantified telic eventuality corresponds to a bare plural NP. Both these units can undergo quantification and be assigned specificity (a VP is assigned specificity by outer aspect and an NP by the determiner). For both categories, quantification has the same effect of making their type of reference non-homogeneous (and perhaps also quantized). Eventualities show the presence of quantification through the so-called tests of telicity. In the present model, however, telicity is distinguished from inner aspect, and it is only the latter that is directly diagnosed in these tests (i.e. the presence of a quantifier in the predicate of the eventuality). The availability of an iterative reading for a non-quantified telic eventuality proves that without a quantifier, a telic eventuality (i.e. an eventuality that defines a canonical singular) can still pattern with atelic eventualities in the inner aspect tests, just as bare plurals pattern in the relevant respects with mass nouns.

A quantifier within the predicate of an eventuality does not only quantify over the eventuality itself, but also over all the non-quantified arguments that it involves. This results in different kinds of correlations between the inner aspect of an eventuality and its non-specific arguments. I therefore argued that it is not the case that the inner aspect of an eventuality depends on the mereological or quantificational properties of its arguments, but the other way around: nonspecific arguments can be quantified by a quantifier that is generated over the entire eventuality.

One of the advantages of the proposed model, the fact that that it establishes a very strict parallel between the NP and the VP, is exploited in Chapter IV. This chapter exploits the consequences of the ability of eventualities to appear as

arguments of other eventualities, just as NPs do. I argued that grammar indeed uses this option and in particular that certain verb forms such as progressive and perfect, as well as verb particles and prefixes, are generated in structures of this kind.

To show the applicability of the model for languages with different verbal and nominal syntax and morphology than English and Dutch, in chapter V, I applied it to data from Serbo-Croatian (S-C). S-C has overt morphological marking both for different aspectual properties and for case. This gives a much more transparent picture of the structural representations and semantic contents of the VP and its arguments. The proposed model gives a unified account for the two different types of verb-prefixes in S-C, the external and the internal ones. Certain predictions of the model are met by the morphological case on the relevant arguments, such as, for instance, the genitive on mass nouns in the object position in telic eventualities. New data that I presented in Chapter V appear to support the theoretical model that I propose.

2. Conclusions

2.1. Theoretical conclusions about the VP

The main contribution of this dissertation is a model of representation of the VP at the interface between semantics and syntax. This model, which establishes a close parallel between the meaning and structure of the VP and the meaning and the structure of the NP, unifies accounts based on decomposition and those that overtly represent notions such as mass division, canonical singular or quantification. Therefore, the quantificational (or mereological) and the decompositional approaches to the VP, which literature often presents as contradictory (Ramchand 2002, Borer 2005b), turn out to be not only compatible, but in fact closely related. A model that combines them has the best of the both worlds.

Verbal and nominal categories are essentially distinguished with respect to their way of establishing reference. Eventualities are built of units that have temporal intervals (states and processes), they are divided together with their temporal interval, the temporal interval is subject to the quantification over the eventuality and finally, the level at which eventualities establish specific reference, which is outer aspect in the present model, is also represented as a temporal predicate relating the eventuality to the reference time.

A further distinction between the two categories, which partly follows from the more fundamental distinction above, is related to the way of defining the canonical singular. The predicate of an NP, according to Borer (2005a), defines canonical singular only if it also contains the predicate that imposes division. Borer identifies this predicate with the one that introduces the classifier in classifier languages. The predicate of division adds the properties of countability and/or of measurability to a mass that it combines with. This combination involves an intersection between the unit of division and the mass that it applies to. In the verbal domain however, the canonical singular is defined by a concatenation of two states. One of these two states has to contain the predicate of dynamicity (*add_{to+/-}*), and this predicate introduces an asymmetry that is similar to the one between classifiers and nouns.

Other general advantages of the model are its simplicity and minimality. The model derives many notions that have usually been stipulated, such as the Goal and Source roles or the relation between decompositional structures and mereological

properties. Similarly, the model derives two fundamental notions in the theory of grammar: the distinction between the verbal and the nominal category and the notion of argumenthood.

I argued that argumenthood corresponds to the capacity to refer, or more directly to the presence of predicates of division and quantification in the observed structure. For a component of some complex meaning to be considered an argument, it must establish its reference independently of the meaning it appears in. Under this definition, both VPs and NPs can be arguments, but both can also be used as predicates if they are non-specific, non-quantified and non-divided.

2.2. Empirical aspects

The dissertation did not focus on one more or less narrow empirical problem, but aimed instead at proposing a universal model for the VP. Still, a number of specific empirical problems have been treated, resulting in elaborated analyses.

In Chapter IV, I analyzed some syntactic and semantic aspects of the temporal adverbials headed by the prepositions *for* and *in*. I proposed a unified account for the temporal use of the preposition *for* (the so-called *for*-phrase) and for its use in the proportional measure phrases.

In the same chapter, I proposed a unified account in terms of the presented model for progressive, perfect and causative constructions. These forms are represented either as states or as telic eventualities of which the direct arguments are not nominal expressions but different kinds of eventualities. The analysis, which is relatively compatible with standard approaches to this problem, also provides some answers for the problem of the imperfective paradox.

Finally, I applied the model to data from Slavic languages, more precisely from Serbo-Croatian. The behavior of the verb affixes in this language, which are directly related to aspect and argument structure, is fully covered by the model. The model reduces the distinction between so-called internal (or lexical) and external (or superlexical) prefixes to the structural level at which they are generated, in combination with the kind of arguments they take. More precisely, a prefix is external if it takes a VP in both its argument positions, and it is internal if its arguments are NPs.

Within the discussion of the Serbo-Croatian paradigm, I introduced some new data in the domain of Serbo-Croatian aspectual suffixes and I showed how the newly established paradigm matches the predictions of the model. Serbo-Croatian affixes are shown to lexicalize the heads of the two functional projections that the model is based on: the VP as the locus of division and the QP as the locus of quantification.

3. Perspectives

The theoretical perspectives of this dissertation that I consider most intriguing are situated at the edges of the dissertation topic and they have to do with more general questions and problems. While presenting the model, I made several general observations which deserve further investigation, among which are the following three.

For the distributive readings of telic eventualities with respect to their non-specific arguments, I have argued that the quantifier that surfaces on the argument is generated at the level of the eventuality and quantifies over all its non-quantified

contents, including the nominal expression on which it appears. Its lexicalization on the NP simply reflects the higher quantifier, in a similar fashion to the way N-words in negative concord reflect a higher negation. If one generalizes this analysis, then at least certain instances of other distributive readings can also be represented as a direct quantification over all the non-quantified referents within the domain of some quantifier. An interesting topic for further research would be to see if it is possible to account for all instances of distributivity in the same way, which would lead to a uniform and technically explicit account for this quite controversial phenomenon.

This same aspect of the presented model leads to an even more general question. The mechanism of quantification argued for above establishes some kind of binding between the eventuality and the relevant participant. This binding is reflected in the fact that irrespective of the quantity, every instance of the canonical singular of the telic eventuality involves a different instance of the canonical singular of the participant represented by a non-specific non-quantified NP. Similarly to what I suggest above, one could hypothesize that each instance of binding can be analyzed in this way: i.e. as a consequence of having two elements which are underspecified for the predicate P within the local domain of the predicate P, under some adequate definition of locality. More concrete consequences might be reflected in the domain of intervention effects, scope, asymmetries between free and bound variables etc.

The decomposition of telic eventualities that is part of the proposed model correlates with the types of meanings that spatial prepositions can involve, in particular locations, sources, directions and goals. There are even prepositions, such as for instance *from* and *to*, which in every use, unambiguously involve meanings related to the telic template. One intriguing question is whether this component of their semantics implies that they have an independent decompositional structure, or that they somehow reflect the decompositional structure of the eventuality in which they are generated (e.g. through agreement). A similar question also holds for morphological case-endings which tend to closely correspond to certain types of participants.

References

- Ahrens, K., & D. Swinney. 1995. "Participant roles and the processing of verbs during sentence comprehension." *Journal of Psycholinguistic Research* 24: 533-547.
- Arsenijević, B. to appear, a. "Slavic verb prefixes are resultative." To appear in *Cahiers Chronos* (selection of papers from the CHRONOS 6 conference in Geneva, September 22-24, 2004).
- to appear, b. "Partitivity and reference." To appear in J. Dotlacil & B. Gehrke (eds.), *Proceedings of the second Syntax AiO Meeting* (Utrecht, November 18, 2005).
- to appear, c. "Slavic verb prefixes." To appear in S. Blaho, E. Schoorlemmer & L. Vicente (eds.), *Proceedings of Console XIV* (Vitoria, December 16-18, 2005).
- 2005a. "Prepositions and event participants." In A. Vilavicencio & V. Kordoni (eds.) *Proceedings of the second ACL-SIGSEM workshop 'The linguistic dimensions of prepositions'*: 39-46.
- 2005b. "One type universe." Ms. Leiden University.
- Bach, E. 1986. "The Algebra of Events." *Linguistics and Philosophy* 9: 1-16.
- Bennett, M & B. Partee. 1972. "Toward the logic of tense and aspect in English." Ms. [Published in Bloomington: Indiana University Linguistics Club 1978.]
- Bennett, W. S., T. Herlick, K. Hoyt, J. Liro & Ana Santisteban. 1990. "A Computational Model of Aspect and Verb Semantics." *Machine Translation* 4:4: 247-280.
- Borer, H. 2005a. *Structuring sense, Volume 1: In name only*. Oxford: Oxford University Press.
- 2005b. *Structuring sense, Volume 2: The normal course of events*. Oxford: Oxford University Press.
- Carter, R. 1976. "Some constraints on possible words." *Semantikos* 1: 27-66.
- Chierchia, G. 1998. "Plurality of mass nouns and the notion of semantic parameter." In S. Rothstein (ed.) *Events and grammar*. Dordrecht: Kluwer Academic Publishers: 53-104.
- Chomsky, N. 1991. "Some notes on economy of derivation and representation." In R. Freidin (ed.), *Principles and parameters in comparative grammar*. Cambridge, MA: MIT Press: 417-454.
- 2001. "Derivation by phase." In M. Kenstowicz (ed.) *Ken Hale, a Life in language*. Cambridge, MA: MIT Press: 1-52.
- Cinque, G. 1999. *Adverbs and functional heads: a cross-linguistic perspective*. Oxford: Oxford University Press.
- Cremers, C. 2002. "'(n) Betekenis berekend." *Nederlandse taalkunde* 7.4: 375-395.
- Davidson, D. 1967. "The logical form of action sentences." In N. Rescher (ed.) *The Logic of Decision and Action*. Pittsburgh: University of Pittsburgh Press: 188-221.
- De Swart, H. 1998. "Aspect shift and coercion." *Natural Language and Linguistic Theory* 16: 347-385.
- Demirdache, H. & M. Uribe-Etxebarria. 1998. "The syntax of temporal relations: a uniform approach to tense and aspect." *WCCFL* 16: 145-159.
- Di Sciullo, A.-M. & R. Slabakova. 2005. "Quantification and aspect." In A. Van Hout, H. de Swart & H. J. Verkuyl (eds.), *Perspectives on aspect*. Dordrecht: Kluwer: 61-80.

- Doetjes, J. 1997. *Quantifiers and selection: on the distribution of quantifying expressions in French, Dutch and English*. Ph.D. Diss. Leiden University.
- Dorr, B. J. 1992. "A two-level knowledge representation for machine translation: lexical semantics and tense/aspect." In J. Pustejovsky & S. Bergler (eds.) *Lexical semantics and knowledge representation: Lecture notes in artificial intelligence 627*. Berlin: Springer Verlag: 269-287.
- Dowty, D. 1979. *Word meaning and Montague grammar. the semantics of verbs and times in generative semantics and in Montague's PTQ*. Dordrecht, London: Reidel.
- 1991. "Thematic proto-roles and argument selection." *Language* 67.3: 547-619.
- Enç, M. 1991. "The semantics of specificity." *Linguistic Inquiry* 22(1): 1-25.
- Engelberg, S. 2002. "The semantics of the progressive." In C. Allen (ed.) *Proceedings of the 2001 Conference of the Australian linguistics society*.
- Farkas, D. & K. É. Kiss. 2000. "On the comparative and absolute readings of superlatives." *Natural Language and Linguistic Theory* 18: 417-455.
- Filip, H. 1997. "Integrating telicity, aspect and NP semantics: the role of thematic structure." In J. Toman (ed.), *Approaches to Slavic linguistics III*. Ann Arbor, MICH: Slavic Publications: 61-96.
- 2003. "Prefixes and the delimitation of events." *Journal of Slavic linguistics* 11.1: 55-101.
- Fillmore, C. 1968. "The case for case." In E. Bach & R. Harms (eds), *Universals in linguistic theory*, New York: Holt, Rinehart and Winston: 1-88.
- Gehrke, B. 2005a. "The aspectual nature of Slavic prefixes." Presented at the LAGB satellite workshop on Perfectivity and telicity in Cambridge, September 03-04, 2005.
- 2005b. "The prepositional aspect of Slavic prefixes and the goal-source asymmetry." In *Proceedings of the ESSLLI workshop on Formal semantics and cross-linguistic data*: 47-56.
- Goldberg, A. 1995. *Constructions: A Construction Grammar approach to argument structure*. Chicago: Chicago University Press.
- Gruber, J. 1976. *Lexical structure in syntax and semantics*, New York: North Holland.
- Hale, K. & S. J. Keyser 1993. "On argument structure and the lexical expression of syntactic relations." In K. Hale & S. J. Keyser (eds.), *The View from Building 20*. Cambridge, MA: MIT Press: 53-109.
- Halle, M. & A. Marantz. 1993. "Distributed Morphology and the Pieces of Inflection." In K. Hale & S. J. Keyser (ed.), *The View from Building 20*. Cambridge, MA: MIT Press: 111-176.
- Harley, H. 2003. "How do verbs get their names? Denominal verbs, manner incorporation, and the ontology of verb roots in English." Ms., University of Arizona.
- Hay, J, C. Kennedy & B. Levin. 1999. "Scalar structure underlies telicity in 'Degree Achievements'." *Proceedings of SALT 9*. Ithaca, NY: Cornell Linguistics Circle Publications: 127-144.
- Heim, I. 2000. "Degree operators and scope." In B. Jackson & T. Matthews (eds.) *Proceedings of SALT X*. Ithaca, NY: CLC Publications: 40-64.

- Hinrichs, E. 1985. "A compositional semantics for aktionsarten and NP reference in English." Ph.D. dissertation. Ohio State University
- Jablónska, P. 2004. "When the prefixes meet the suffixes." *Nordlyd* 32.2 (Special issue on Slavic prefixes): 363-401.
- Jackendoff, R. 1977. *X-bar syntax: a study of phrase structure*. Cambridge, MA: MIT Press.
- 1990. *Semantic structures*. Cambridge, MA: MIT Press.
- 1996. "The proper treatment of measuring out, telicity, and perhaps even quantification in English." *Natural language and linguistic theory* 14: 305-354.
- Keenan, E. L. 1974. "The functional principle: generalizing the notion of 'subject of'." In *Papers from the 10th meeting of the Chicago Linguistic Society*: 298-309.
- Kempen, G. 1970. *Memory for word and sentence meanings. A set-feature model*. PhD Dissertation, University of Nijmegen.
- Kempen, G. & K. Harbusch. 2002. "Performance grammar: a declarative definition." In A. Nijholt, M. Theune & H. Hondorp (eds.) *Computational linguistics in the Netherlands 2001*. Amsterdam: Rodopi: 148-162.
- Kenny, A. 1963. *Action, emotion, and will*. London: Routledge and Kegan Paul.
- Kiparsky, P. 1998. "Partitive case and aspect." M. Butt & W. Geuder (eds.) *The projection of arguments: lexical and compositional factors*. Stanford: CSLI Publications: 275-307.
- Koenig, J.-P.; G. Mauner; B. Bienvenue. 1993. "Arguments for adjuncts." *Cognition*, Volume 89, Number 2: 67-103.
- Koopman, H. & D. Sportiche. 1991. "The position of subjects." *Lingua* 85. 211-258.
- Krifka, M. 1989. "Nominal reference, temporal constitution and quantification in event semantics." In R. Bartsch, J. van Benthem & P. van Emde Boas (eds.), *Semantics and contextual expressions*. Dordrecht: Foris: 75-115.
- Krifka, M. 1995. "Telicity in movement." In P. Amsili, M. Borillo & L. Vieu (eds.), *Time, space and movement*. Chateau de Bonas: Université Paul Sabatier & Université Toulouse-Le Mirail: 63-76
- 1991. "Four thousand ships passed through the lock: object-induced measure functions on events." *Linguistics and Philosophy* 13: 487-519.
- 1992. "Thematic relations as links between nominal reference and temporal constitution." In I. Sag & A. Szabolcsi (eds.), *Lexical matters*. Stanford, CA: CSLI Publications: 29-53.
- 1998. "The origins of telicity." In Susan Rothstein (ed.), *Events and grammar*. Dordrecht: Kluwer: 197-235.
- Larson, R. 1988. "On the double object construction." *Linguistic Inquiry* 19: 335-392.
- Levin, B. & M. Rappaport Hovav. 1999. "Two structures for compositionally derived events." *Proceedings of SALT 9*: 199-223.
- Levin, B. 1993. *English verb classes and alternations: a preliminary investigation*. Chicago, IL: The University of Chicago Press.
- Light, M. & L. Schubert. 1997. "Knowledge representation for lexical semantics: is standard first order logic enough?" *Proceedings of the second international workshop on computational semantics*, Grenoble, France.

- Lüdeling, A. 1998. *On particle verbs and similar constructions in German*. Dissertation, Tübingen. (Published in 2001 by CSLI, Stanford.)
- Ludlow, P. 2002. "LF and Natural Logic." In G. Preyer (ed.), *Logical form, language and ontology*. Oxford: Oxford University Press: 132-168.
- Maienborn, C. 2005. "On the limits of the Davidsonian approach. The case of copula sentences." *Theoretical Linguistics* 31/3: 275–316..
- Martí, L. 2003. *Contextual variables*, Ph.D. dissertation, Storrs, CT: University of Connecticut.
- Moltmann, F. 1991. "Measure adverbials." *Linguistics and Philosophy* 14: 629-660.
- Montague, R. 1973. "The proper treatment of quantification in ordinary English." In: K. J. J. Hintikka, J. M. E. Moravcsik, P. Suppes (eds.) *Approaches to natural language*. Dordrecht: Reidel: 221-242.
- Pan, H. 1993. "Interaction between Adverbial Quantification and Perfective Aspect." In L. Stvan, S. Ryberg, M. B. Olsen, T. Macfarland, L. DiDesidero, A. Bertram & L. Adams (eds.) *FLSM III: Papers from the Third annual meeting of the Formal linguistics society of Mid America*. Bloomington, Indiana: Indiana University Linguistics Club: 266-80.
- Parsons, T. 1990. *Events in the semantics of English: a study in subatomic semantics*. Cambridge, MA: MIT Press.
- Perlmutter, D. M. 1978. "Impersonal passives and the unaccusative hypothesis." In *Proceedings of the Fourth Annual Meeting of the Berkeley Linguistics Society*. Berkeley: Berkeley Linguistics Society, University of California Berkeley: 157-189.
- Pietroski, P. 2002. "Function and concatenation." In G. Preyer & G. Peters (eds.) *Logical form and language*. Oxford: Clarendon Press: 91-117.
- Pustejovsky, J. 1995. *The generative lexicon*, Cambridge, MA: MIT Press.
- Ramchand, G. 2002. "First phase syntax." Ms. Oxford University.
- 2004. "Time and the event: The semantics of Russian prefixes." *Nordlyd* 32.2 (Special issue on Slavic prefixes): 323–361.
- Reckman, H. 2005. "Unexpressed arguments for nominalizations." Ms. LUCL, Leiden University.
- Reinhart, T. 2002. "The theta system – An overview." *Theoretical linguistics* 28. Berlin: Mouton: 229-290
- Reiter, E. & R. Dale. 2000. *Building natural language generation systems*. Cambridge: Cambridge University Press.
- Rothstein, S. 2003. *Structuring of events: a study in the semantics of lexical aspect*. Oxford: Blackwell Publishing.
- Saint-Dizier, P. 1999a. "Alternation and verb semantic classes for French: Analysis and class formation." In Saint-Dizier (1999b): 139-170.
- 1999b. (ed.) *Predicative forms in natural language and in lexical knowledge bases*. Kluwer Academic Publishers.
- Shannon, T. F. 1988. "Perfect Auxiliary Variation as a Function of Aktionsart and Transitivity." In J. Edmonds *et al* (eds.) *Proceedings of the Western Conference on Linguistics WECOL I*: 254-266.
- Sio, J. 2006. *Modification and reference in the Chinese nominal*. PhD Dissertation, Leiden University.
- Smith, C. S. 1991. *The parameter of aspect*. Dordrecht: Kluwer.

- Snyder, W. 2001. "On the nature of syntactic variation: evidence from complex predicates and complex word-formation." *Language* 77: 324–342.
- Stanley, J. 2002. "Nominal restriction." In G. Peters & G. Preyer (eds.) *Logical form and language*. Oxford: Oxford University Press: 365-388.
- Steedman, M. 2000. "Information Structure and the Syntax-Phonology Interface." *Linguistic Inquiry* 31(4):649-689.
- Svenonius, P. 1996. "The verb-particle-alternation in the Scandinavian languages." Ms. University of Tromsø.
- 2004. "Slavic prefixes inside and outside VP." *Nordlyd* Vol. 32, Nr. 2 - Slavic Prefixes: 205-253.
- Tenny, C. 1994. *Aspectual roles and the syntax-semantics interface*. Dordrecht: Kluwer.
- Ter Meulen, A. G. B. 1995. *Representing time in natural language. The dynamic interpretation of tense and aspect*. Cambridge: MIT Press, Bradford Books.
- Travis, L. 1991. "Inner Aspect and the Structure of VP." Ms. McGill University.
- Uriagereka, J. 2002. *Derivations. exploring the dynamics of syntax*. London/New York: Routledge.
- Van Valin, R. D., Jr. & R. J. LaPolla. 1997. *Syntax: structure, meaning & function*. Cambridge: Cambridge University Press.
- Vendler, Z. 1957. "Verbs and times." *Philosophical Review* 56: 143-160.
- Verkuyl, H. 1972. *On the compositional nature of the aspects*. Dordrecht: Reidel.
- 1993. *A theory of aspectuality*. Cambridge: Cambridge University Press.
- 2000. "Events as individuals: aspectual composition and event semantics." In J. Higginbotham, F. Pianesi, A.C. Varzi (eds.). *Speaking of events*. New York, Oxford: Oxford University Press: 169-205.
- Vlach, F. 1981. "The Semantics of the progressive." In P. J. Tedeschi & A. Zaenen (eds.) *Tense and Aspect (Syntax and Semantics 14)*. New York, NY: Academic Press New York et al.: 271-292.
- Westerstahl, D. 1985. "Logical constants in quantifier languages." *Linguistics and Philosophy* 8: 387-413.
- White, M. 1994. "A computational approach to aspectual composition." PhD dissertation, University of Pennsylvania.
- Wiesman, F., S. Bocconi, B. Arsenijević, Y. Bachvarova, N. Roos & L. Schomaker. 2003. "Intelligent information retrieval and presentation with multimedia databases." In *Proceeding of the fourth Dutch-Belgian information retrieval workshop*. Amsterdam: Institute for Logic, Language and Computation, University of Amsterdam: 52-56.
- Zamparelli, R. 1995. *Layers in nominal structure*. Phd dissertation. University of Rochester.
- Zeijlstra, H. 2004. *Sentential negation and negative concord*. PhD Dissertation, University of Amsterdam.
- Zhang, N. 2002. "Counting and classifying eventualities in Chinese." Ms. <http://www.usc.edu/dept/LAS/ealc/chinling/articles/Classification.PDF>.
- Žaucer, R. 2002. *The role of verbal prefixes in Slavic: evidence from Slovenian locative denominal verbs*. Master's thesis, University of Ottawa.

Samenvatting in het Nederlands (Summary in Dutch)

Deze dissertatie gaat hoofdzakelijk over het inwendige aspect van de werkwoordsgroep (VP) en de verhouding tussen decompositionele en kwantificatiele benaderingen van dit probleem. Decompositionele benaderingen zoals Ramchand (2002) en Pustejovsky (1995) ontleden gebeurtenissen in eenvoudigere bestanddelen, geordend in een structuur. Onder dit gezichtspunt is een gebeurtenis telisch als deze bij ontleding aantoonbaar een resultaatief bestanddeel bevat; dit bestanddeel wordt ook omschreven als de cumulatieve of terminatieve component, of als de *telos*. Kwantificatiele benaderingen als Krifka (1998) en Borer (2005b) beschouwen teliciteit als een eigenschap van het predikaat of van een gebeurtenis, die doorgaans wordt beschreven als begrensdheid, als het ontbreken van de subinterval-eigenschap of als een gespecificeerde hoeveelheid. Het belangrijkste voordeel van de decompositionele benaderingen is dat zij de wisselwerking van syntaxis en semantiek in de VP onmiddellijk in verband brengen met de conceptuele structuur van de gebeurtenis. Kwantificatiele benaderingen verstoren het beeld in dit opzicht, omdat zij effecten, zoals distributieve lezingen, introduceren die geen typische interpretatieve bestanddelen van het VP-domein zijn. Daarentegen hebben de kwantificatiele benaderingen als belangrijkste voordeel dat zij aan (de predikaties van) gebeurtenissen en nominale uitdrukkingen overeenkomstige of gelijke eigenschappen toekennen. Aldus doen zij recht aan het verschijnsel van incrementele actanten (actanten die samenvallen met de gebeurtenis waaraan ze deel hebben), door de predikaten van gebeurtenissen en de predikaten van hun argumenten op elkaar te betrekken.

Dit proefschrift biedt een nieuwe benadering die niet alleen de twee hierboven genoemde benaderingen combineert maar ook laat zien hoe deze onmiddellijk onderling gerelateerd zijn en hoe enkele kwantificatiele eigenschappen afgeleid kunnen worden uit decompositie. Ik ga uit van een betrekkelijk traditionele decompositionele visie waarin een telische gebeurtenis bestaat uit één proces en één toestand (onder meer Pustejovsky 1995, Parsons 1990). Ik verwijs naar het proces als de initiële deelgebeurtenis, en naar de toestand als de resultaatieve deelgebeurtenis. Deze structuur, hier aangeduid als het telisch templaat, is onderworpen aan verschillende beperkingen. De belangrijkste beperking is de eis dat precies die eigenschap van die participant die bij de initiële deelgebeurtenis betrokken is, een vaste waarde moet krijgen in de resultaatieve deelgebeurtenis. Door deze beperking op te leggen, wordt een faseovergang deel van de interpretatie van het telisch templaat: er is een punt waar de opeenvolging van waarden die in de initiële deelgebeurtenis toevallen aan de betrokken eigenschap van de betrokken actant, omslaat naar de vaste waarde die eraan wordt toegekend in de resultaatieve deelgebeurtenis. Met andere woorden: er is een punt in de tijd waar de initiële deelgebeurtenis eindigt en de resultaatieve deelgebeurtenis begint.

Ik laat zien hoe de component die de faseovergang in het telisch templaat markeert, een rekeneenheid definieert voor elke gebeurtenis die het templaat vertegenwoordigt. Terwijl atelische gebeurtenissen, processen en toestanden de eigenschappen vertonen van een massa - ze zijn onbegrensd, ongedeeld en homogeen - zijn telische gebeurtenissen telbaar, en de rekeneenheid is de

faseovergang van het proces in de initiële deelgebeurtenis naar de toestand in de resultatieve deelgebeurtenis. Hierdoor ontstaat een onmiddellijke correspondentie tussen de component van de faseovergang in de semantiek van de VP en de classificerende component in de NP (te weten, grammaticaal getal) die per saldo ook een rekeneenheid definieert. En omdat telbaarheid een eigenschap is uit het kwantificatiele domein, is de overgangskomponent de grootte die het directe verband legt tussen de decompositionele en de kwantificatiele aspecten van gebeurtenissen. Als de rekeneenheid is gedefinieerd, kan het predikaat van de telische gebeurtenissen aan telling worden onderworpen. Aldus heeft teliciteit effecten in het kwantificatiele domein.

In het template wordt de relatie tussen de initiële en de resultatieve deelgebeurtenis weergegeven als verketening. Een faseovergang kan worden beschouwd als een asymmetrische verketening van twee fases, in dit geval een proces en een toestand. Derhalve wordt het template structureel voorgesteld als een predikatie die betrekking heeft op een tweeplaatsig verketeningspredikaat en twee argumenten: de initiële en de resultatieve deelgebeurtenissen; dit is uitgedrukt in (288). Het predikaat dat als *add-to* is gekenmerkt in het hoofd van de initiële deelgebeurtenis draagt de procesinterpretatie aan. In de specificieerder van de initiële deelgebeurtenis staat de actant die deze dynamiek initieert (Participant₁), en in het complement staat de actant waarop het proces invloed uitoefent (Participant₂). In de resultatieve deelgebeurtenis wordt de specificieerderpositie ingenomen door dezelfde actant als die waarop de initiële deelgebeurtenis inwerkt (Participant₂), en deze actant wordt geïnterpreteerd als de drager van de resulterende toestand. Het lexicale predikaat in het hoofd van deze deelgebeurtenis en de actant in het complement (Participant₂) specificeren samen de eindwaarde van de veranderde eigenschap van Participant₂.

(1) Het telisch template

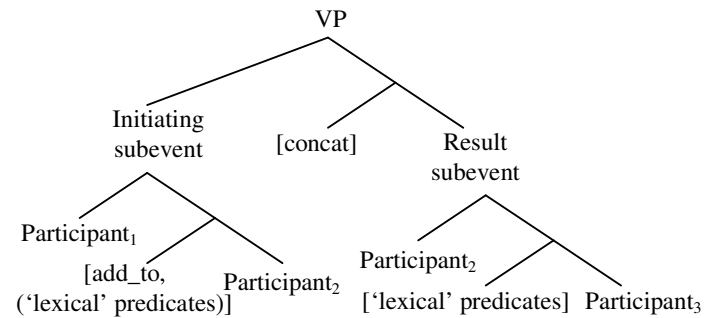

Dit wordt verduidelijkt in (2). In de initiële deelgebeurtenis introduceert John enige dynamiek, waarin controle over de initiatie, contact tussen hem en de beïnvloede actant en de plaatseigenschap een rol spelen. De resultatieve deelgebeurtenis specificiert de plaatseigenschap van de tas als in (of omvat door de plaats van) de kast. De interpretatie van de gehele VP komt hierop neer dat John een proces in gang zet dat effect heeft op de plaats van de zak en op het einde waarvan de zak in de kast is, en dat de initiële component gevolgtrekkingen toelaat wat betreft de

controle van John, zijn contact met de zak, en wellicht een aantal vergelijkbare predikaten die hier ter wille van de eenvoud niet zijn opgevoerd.

(2) Een voorbeeld: 'John put the bag into the closet.'

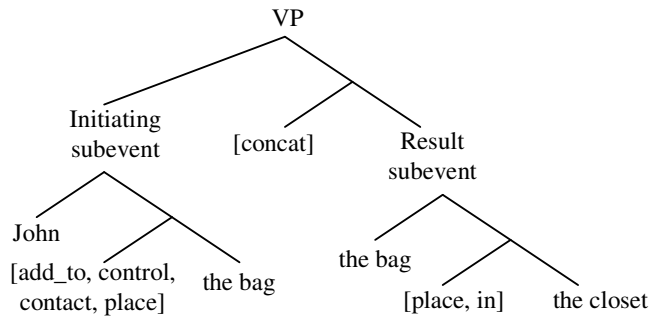

Van uitdrukkingen die in het telisch templaar zijn afgeleid, wordt beargumenteerd dat ze de werkwoordelijke tegenhangers zijn van kale meervouden, naamwoordelijke uitdrukkingen die gekenmerkt zijn voor telbaarheid maar die elke kwantificatie missen. Net zoals het naamwoordelijke meervoud, kan het telisch templaar doelwit van kwantificatie zijn. Kwantificerende predikaten projecteren de kwantificatiegroep (QP) en wel onmiddellijk boven de VP. Er wordt voorts betoogd dat toetsen voor inwendig aspect feitelijk alleen aangeven of een gebeurtenis kan worden geïnterpreteerd met een kwantificerend predikaat, en aldus gebeurtenissen onderverdelen in gekwantificeerde en niet-gekwantificeerde. Omdat QP's alleen worden geprojecteerd over telbare predikaten en het telisch templaar de rekeneenheid voor het predikaat van een gebeurtenis definieert, vormen de gekwantificeerde gebeurtenissen een deelverzameling van de telische gebeurtenissen. Maar in de lezing van kaal meervoud, gewoonlijk aangeduid als de iteratieve lezing, zijn telische gebeurtenissen niet gekwantificeerd, hetgeen aantoont dat teliciteit en inwendig aspect twee verschillende eigenschappen zijn.

Summary

The main topic of the dissertation is the nature of inner aspect of the Verb Phrase (VP), and the relation between the decompositional and the quantificational approaches to this problem. Decompositional approaches, such as Ramchand (2002) or Pustejovsky (1995), analyze eventualities into simpler components, organized by some kind of structure. In this view, an eventuality is telic if, in decomposition, it can be shown to involve a result component (also referred to as the culmination or termination component, or as the *telos*). Quantificational approaches, such as Krifka (1998) or Borer (2005b) see telicity as a property of the predicate of an eventuality, usually described as boundedness, lack of the subinterval property, or a specified quantity. The major advantage of the decompositional approaches is that they directly match the syntax-semantics interface of the VP with the conceptual image of an eventuality. Quantificational approaches blur the picture in this respect, because they involve effects like distributive readings, which are not a typical interpretational component of the VP domain. On the other hand, the major advantage of the quantificational approaches is that they assign similar or identical properties to (the predicates of) eventualities and nominal expressions. This enables them to capture the phenomenon of incremental themes (participants that appear to measure out the eventuality in which they take part), by relating the predicates of eventualities and those of their arguments.

The dissertation presents a new approach, which not only combines the two approaches above, but also shows how they are directly mutually related, and how some quantificational properties can be derived from the domain of decomposition. I start from a relatively traditional decompositional view, in which a telic eventuality is composed of one process and one state (among others, Pustejovsky 1995; Parsons 1990). I refer to the process as the initiating subevent and to the state as the result subevent. This structure, referred as the telic template, involves several restrictions, the major one requiring that the same property of the same participant that is affected in the initiating subevent has to be assigned a fixed value in the result subevent. Including this restriction also includes a phase transition as part of the interpretation of the telic template: there is a point where the sequence of values assigned to the affected property of the affected participant in the initiating subevent switches to the fixed value assigned to it in the result subevent. In other words, there is one temporal point at which the initiating subevent ends and the result subevent starts.

I show how the phase transition component of the telic template defines a unit of counting for any eventuality represented by the template. While atelic eventualities, processes and states, have the properties of a mass – they are unbounded, undivided and homogeneous – telic eventualities are countable, and the unit of counting is one phase transition from the process in the initiating subevent, to the state in the result subevent. This establishes a direct correspondence between the phase transition component in the semantics of the VP and the classifier component in the NP (i.e. grammatical number), which has the same effect of defining the unit of counting. And, since countability is a property from the domain of quantification, the component of phase transition is the element that directly connects the decompositional and

the quantificational aspects of eventualities. Having defined a unit of counting, the predicate of a telic eventuality can be subject to countable quantification. This is how telicity produces effects in the domain of quantification.

In the template, the relation between the initiating and the result subevent is represented as a concatenation. A phase transition can be seen as an asymmetric concatenation of two phases, in this case a process and a state. This is why the template is structurally represented as a predication involving a two place predicate of concatenation and two arguments: the initiating and the result subevent, as in (3). The predicate marked as *add_to* in the head of the initiating subevent contributes the process interpretation. In the specifier of the initiating subevent stands the participant that initiates this dynamicity (Participant₁), and in the complement stands the participant that is affected by the process (Participant₂). In the result subevent, the specifier position is taken by the same participant that is affected in the initiating subevent (Participant₂), and it is interpreted as the bearer of the result state. The lexical predicate in the head of this subevent, together with the participant in the complement (Participant₃), specify the result value of the affected property of Participant₂.

(3) The telic template

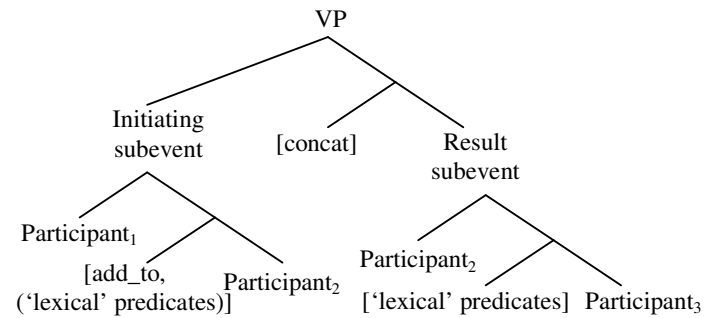

This is illustrated in (4). In the initiating subevent, John initiates some dynamicity, involving control over this initiation, contact between him and the affected participant and the property of place. The result subevent specifies the place property of the bag as in (or contained by the place of) the closet. The interpretation of the entire VP is that John initiates a process that affects the place of the bag and at the end of which the bag is in the closet, and that the initiating component involves control by John, his contact with the bag, and perhaps a number of other similar predicates that are not represented here for reasons of simplicity.

- (4) An example for the template: 'John put the bag into the closet.'

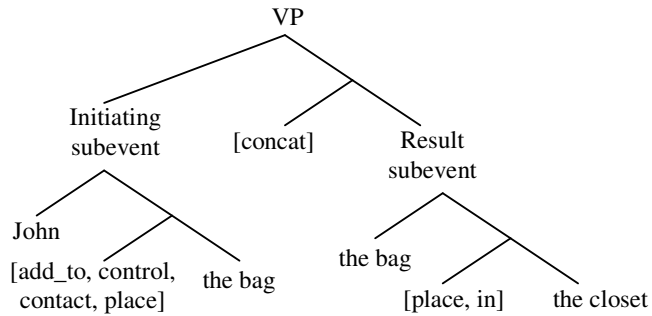

Expressions derived in the telic template are argued to present the verbal counterparts of bare plurals, nominal expressions specified for countability, but lacking any quantification. Just like the nominal plural, the telic template can be subject to quantification. Quantifying predicates project the Quantification Phrase (QP), appearing immediately above the VP. It is argued that tests of inner aspect in fact only indicate whether an eventuality can be interpreted with a quantifying predicate, subdividing eventualities into the quantified and non-quantified ones. Since QPs can only project over countable predicates and the telic template defines the unit of counting for the predicate of an eventuality, the set of quantified eventualities is a subset of the set of telic eventualities. However, in their bare plural readings, more commonly referred to as the iterative readings, telic eventualities are non-quantified, which shows that telicity and inner aspect are two different properties.

Curriculum Vitae

Boban Arsenijević was born in Niš, Serbia, on the 5th of November 1974. He obtained his BA in Serbian Language and Literature at the University in Niš in 1997, and then went to the University of Veliko Tarnovo, Bulgaria, where he spent two years teaching at the Slavic Languages department. He defended his MA thesis in linguistics at the University of Belgrade in 2001, and moved to Leiden to enroll in the Advanced Master's Program of the Faculty of Arts. In 2002 he started his work as a PhD student at the Leiden University Centre for Linguistics (LUCL). As of October 1st 2006, he will take up a postdoc position at the Amsterdam Center for Language and Communication (ACLCL) of the University of Amsterdam.