



Universiteit  
Leiden  
The Netherlands

## **The Syntax of object marking in Sambia : a comparative Bantu perspective**

Riedel, K.

### **Citation**

Riedel, K. (2009, December 10). *The Syntax of object marking in Sambia : a comparative Bantu perspective*. LOT dissertation series. Retrieved from <https://hdl.handle.net/1887/14502>

Version: Not Applicable (or Unknown)

License: [Licence agreement concerning inclusion of doctoral thesis in the Institutional Repository of the University of Leiden](#)

Downloaded from: <https://hdl.handle.net/1887/14502>

**Note:** To cite this publication please use the final published version (if applicable).

# The Syntax of Object Marking in Smbaa

A comparative Bantu perspective

The research reported here was conducted in the context of the project “Word order and morphological marking in Bantu” (360-70-170) led by Prof. Dr. L. L. Cheng and Prof. Dr. T. C. Schadeberg, funded by the Dutch organisation for scientific Research (NWO).

Published by

LOT  
Janskerkhof 13  
3512 JK Utrecht  
the Netherlands

phone: +31 30 253 6006  
fax: +31 30 253 6000  
e-mail: [lot@uu.nl](mailto:lot@uu.nl)  
<http://www.lotschool.nl/>

Cover illustration: *Daladala on the road to Lushoto* by Kristina Riedel

ISBN: 978-90-78328-96-4  
NUR: 616

Copyright © 2009 Kristina Riedel. All rights reserved.

The Syntax of Object Marking in Sambia  
A comparative Bantu perspective

Proefschrift

ter verkrijging van  
de graad van Doctor aan de Universiteit Leiden,  
op gezag van Rector Magnificus prof. mr. P.F. van der Heijden,  
volgens besluit van het College voor Promoties  
te verdedigen op donderdag 10 december 2009  
klokke 16.15 uur

door

Kristina Riedel

geboren te Berlijn, Duitsland  
in 1980

Promotores: Prof. dr. L. L. Cheng  
Prof. dr. T. C. Schadeberg

Co-promotor: Dr. L. C. Buell

Commissieleden: Prof. dr. K. Demuth (Brown University)  
Prof. dr. M. P. G. M. Mous  
Dr. L. Marten (SOAS)  
Dr. C. J. W. Zwart (RUG)

---

## Contents

---

<b>Contents</b>	<b>v</b>
<b>List of Tables</b>	<b>ix</b>
<b>List of Figures</b>	<b>ix</b>
<b>Acknowledgements</b>	<b>xi</b>
<b>Notes on Glossing</b>	<b>xiii</b>
<b>Abbreviations</b>	<b>xv</b>
<b>1 Introduction</b>	<b>1</b>
1.1 The topic of this thesis . . . . .	2
1.2 Object marking across Bantu . . . . .	3
1.3 Concepts and terminology . . . . .	6
1.4 Languages discussed . . . . .	8
1.4.1 Data collection . . . . .	9
1.5 Theoretical background . . . . .	10
1.6 Overview of the thesis . . . . .	11
<b>2 Notes on Sambia</b>	<b>13</b>
2.1 Classification and geographic location . . . . .	13
2.2 Literature . . . . .	16
2.3 Grammatical notes on Sambia . . . . .	17
2.3.1 Phonology . . . . .	17
2.3.2 Morphosyntax . . . . .	20
2.3.3 Subject and object marking . . . . .	26
2.3.4 Word order . . . . .	27
2.3.5 Tense-aspect marking and syntax . . . . .	28
Conjoint and disjoint verbs . . . . .	31
2.3.6 Relative clauses . . . . .	35

<b>3</b>	<b>Object marking in Bantu</b>	<b>41</b>
3.1	The agreement/pronoun distinction . . . . .	41
3.2	Obligatory object marking . . . . .	44
3.2.1	Obligatory object marking in Sambia and Swahili . . . . .	44
3.2.2	Definiteness and specificity . . . . .	48
3.3	Object marking and dislocation across Bantu . . . . .	53
3.3.1	Bresnan and Mchombo (1987) . . . . .	55
3.3.2	Local doubling . . . . .	59
	Co-occurrence and multiple object markers . . . . .	60
	The conjoint/disjoint alternation and object marking . . . . .	63
	VP boundary tones and object marking . . . . .	65
	Word order and object marking . . . . .	66
	Conclusions . . . . .	66
3.3.3	Against the right-dislocation analysis for Haya . . . . .	67
3.3.4	Conclusions . . . . .	74
3.4	Variation in object morphosyntax across Bantu . . . . .	74
3.4.1	Duranti's topicality hierarchy . . . . .	74
3.4.2	Multiple object markers . . . . .	75
3.4.3	Asymmetry . . . . .	78
3.4.4	Baker (2008) on Sambia and Haya . . . . .	84
3.5	Conclusion . . . . .	89
<b>4</b>	<b>The syntax of object marking</b>	<b>91</b>
4.1	Julien (2002) on Bantu verb syntax . . . . .	92
4.2	The syntax of Agree . . . . .	95
4.3	Object marking and Sambia syntax . . . . .	98
4.3.1	Subject agreement . . . . .	99
4.3.2	Object agreement . . . . .	101
4.3.3	Double object constructions . . . . .	104
4.3.4	Locative object marking . . . . .	109
4.3.5	Feature structure and obligatory object marking . . . . .	115
4.3.6	Agreement and case . . . . .	117
4.4	Object agreement in other Bantu languages . . . . .	123
4.4.1	Haya object marking . . . . .	123
4.4.2	Swahili . . . . .	131
4.5	Conclusions . . . . .	133
<b>5</b>	<b>The Person Case Constraint in Bantu</b>	<b>135</b>
5.1	The Person Case Constraint . . . . .	136
5.2	PCC effects in Haya and Sambia . . . . .	139
5.3	PCC effects and the syntax of agreement . . . . .	142
5.4	The PCC and object marking across Bantu . . . . .	145
5.5	Conclusions . . . . .	152

<b>6</b>	<b>Object marking in <i>wh</i>-environments</b>	<b>153</b>
6.1	Object marking in <i>wh</i> -environments . . . . .	155
6.1.1	<i>Wh</i> -questions . . . . .	155
6.1.2	Sambaa human objects . . . . .	158
6.1.3	Object marking in relative clauses . . . . .	159
6.1.4	Object marking in <i>wh</i> -clefts . . . . .	161
6.2	Structural implications . . . . .	162
6.2.1	Conjoint/disjoint forms in <i>wh</i> -questions . . . . .	162
6.2.2	The Immediate After the Verb (IAV) Position . . . . .	163
6.2.3	Word order effects . . . . .	164
6.2.4	Evidence for a structural IAV . . . . .	167
6.2.5	Representing the IAV position in syntax . . . . .	170
	Conclusions . . . . .	172
6.2.6	Sambaa relative clause structure . . . . .	172
6.3	Questions and relative clauses in Haya . . . . .	180
6.3.1	Structure . . . . .	181
6.3.2	Object marking . . . . .	183
6.3.3	Definiteness and specificity . . . . .	186
6.4	Conclusions . . . . .	187
<b>7</b>	<b>Object marking and coordination</b>	<b>189</b>
7.1	Coordination agreement . . . . .	192
7.2	Object marking in coordinate structures . . . . .	193
7.3	Subject marking in coordinate structures . . . . .	197
7.4	Comparing pre- and postverbal coordinate NPs . . . . .	198
7.5	Coordination and obligatory agreement . . . . .	199
7.6	Coordination in Haya . . . . .	201
7.7	Swahili coordinate structures . . . . .	203
7.8	Conclusions . . . . .	207
<b>8</b>	<b>Conclusions and issues for further research</b>	<b>209</b>
8.1	Conclusions . . . . .	209
8.2	Areas for further research . . . . .	212
	<b>References</b>	<b>215</b>
	<b>Index</b>	<b>229</b>
	<b>Samenvatting</b>	<b>231</b>
	<b>Muhtasari</b>	<b>235</b>
	<b>Curriculum Vitae</b>	<b>239</b>



---

## List of Tables

---

2.1	Consonant Inventory of Smbaa . . . . .	18
2.2	IPA equivalents of orthographic symbols used in this thesis . . . . .	18
2.3	Smbaa Noun Classes . . . . .	21
2.4	Verbal Extensions . . . . .	24
2.5	Smbaa Tense-Aspect Markers . . . . .	29
2.6	Conjoint and Disjoint Forms in Smbaa . . . . .	33
2.7	Smbaa Relative Markers . . . . .	36
3.1	Categories which trigger obligatory object marking per language . . . . .	53
3.2	Summary of Baker's tests . . . . .	89
7.1	Agreement with conjoint NPs . . . . .	199

---

## List of Figures

---

1.1	Location of Bantu languages discussed . . . . .	9
2.1	Smbaa and neighbouring languages . . . . .	15



---

## Acknowledgements

---

There is a Sambia saying which goes:

**Hekuna muima ushenao bontokeo.**

which loosely translates to say that no matter how high a mountain is, one will eventually reach its peak. I here want to thank some of the people without whom the long, steep ascent would have been all but impossible.

First of all, thanks to my teammates/supervisors in the project “Word order and morphological marking in Bantu”: Leston C. Buell, Lisa Cheng, Thilo Schadeberg and Jenneke van der Wal.

LUCL was a great place for working towards a PhD dealing with theoretical syntax, African languages and finally field linguistics. I thank all the members and guests of the institute for creating such a stimulating research environment at Leiden University, particularly: Azeb Amha, Felix Ameka, Boban Arsenijević, Sandra Barasa, Birgit Bexten, Camelia Constantinescu, Maud Devos, Tolemariam Fufa, Margarita Gulian, Stella Gryllia, Melanie Jouitteau, Anne-Christie Hellenthal, Pepijn Hendricks, Maarten Kossmann, František Kratochvíl, Nana Kusuma, Mercy Lamptey, Frank Landsbergen, Boya Li, Aníko Lipták, Maarten Mous, Peter Muriungi, Victoria Nyst, Ongaye Oda, Hilke Reckmann, Milan Rezac, Johan Rooryck, Martin Salzmann, Erik Schoorlemmer, Joanna Sio, Kateřina Součková, Sander Steeman, Assimakis Tseronis, Luis Vicente, Rebecca Voll, Mark de Vos and Leo Wong; as well as the participants of the Fieldwork Forum, the Generals Meeting and various reading and study groups over the years. For all the practical and administrative support I received at LUCL, I wish to thank Barbara Floris, Gea Hakker, Jeroen van der Weijer and Margreet Verra; as well as Jos Pacilly for his help with the recording equipment.

A number of linguists have contributed to this work in one way or the other. I particularly want to thank: Enoch Aboh, Katherine Demuth, Alexis Dimitriadis, Ruth Kempson, Nancy Kula, Lutz Marten, Yukiko Morimoto, Gerardo Fernández-Salgueiro

and Jan-Wouter Zwart. Special thanks to Ridder Samson (my first Swahili teacher) and Lutz Marten without whom I might never have become a linguist.

The final parts of this thesis were completed at ZAS (Centre for General Linguistics). Since starting my position there, I have been fortunate to work with and around: Laura Downing, Tonjes Veenstra, Muhsina Alleesaib and Stephanie Solt, amongst many others.

I have benefitted greatly from presenting my work at a number of workshops and conferences, including the meetings of the *SOAS-ZAS-Leiden Bantu Network*, *Bantu 1*, *Bantu 2*, *ACAL 39*, *ACAL 40* and the *Movement and Word Order in Bantu* conference. Thanks to the audiences of these meetings.

I am grateful to the Tanzanian Commission for Science and Technology (COSTECH) who have granted me a number of research permits to cover the fieldwork needed to collect the data reported on here. While staying in Tanzania, I also received support from linguists at UDSM, particularly Josephat Rugemalira and the other members of the LOT project.

Thanks to Francis Ndi for Limbum judgements and help getting data on other Cameroonian languages. Thanks to Kweba Bulemo who helped me in the Netherlands when I wanted to start collecting data on more Tanzanian languages both with giving Jita judgements and helping me find informants. Thanks to Peter Ndyetabula for Haya data; and to Rahma A. Muhdhar, Eric Bakilana and a number of my other Tanzanian friends who gave Swahili judgements at times.

Amongst the most important people in the production of this piece of work are Monica Martin, Stella Seifu, Abdiel Kiango and Kassim Kimweri, who provided the main part of the Sambia data. It's been a great pleasure working with you over the past years. *Hongesai sana!*

During the long fieldtrips, I received a lot of support from my close friends in Dar es Salaam: Pendo S. Malangwa, Jacqueline H. Mgumia and Rahma A. Muhdhar. *Asanteni sana, wapendwa!* In Lushoto, many people helped me in getting settled, finding informants, going about my research and having fun. Many thanks to: Maya Abe, Boka, Marlene Dias, William James, Yassin Kibungi, Matulo, Ernest Mbondei, Magreth Julius Mhando and Tony Nikitas.

This thesis was written in  $\LaTeX$ . The data was transcribed using ELAN, Praat and Audacity. I am grateful to all those that write software and make it freely available. And I want to thank Leston Buell and Alexis Dimitriadis for helping me solve all my  $\LaTeX$  issues when preparing the document.

Thanks to my paronyms: Stella Gryllia and Kweba Bulemo; to Nana Kusuma for help with the books, and Jenneke van der Wal and Pendo Malangwa for helping with the translations of the summary.

Lastly, my heartfelt thanks to my parents, Eric, my family and my "Kiwi family" for all their support.

---

## Notes on Glossing

---

Glosses of examples throughout the text have been modified for consistency. Occasionally, the translations have also been modified, where this has been done, it is indicated.

All examples where no reference to a source follows the language name have been collected by the author.

**Bantu glossing conventions** Numbers preceding a noun indicate the noun class. For example, *kitabu* ‘book’ is glossed as ‘7book’. This means that *kitabu* belongs to noun class 7. The numbers in the glosses for SM, OM and RM also refer to the noun class, whenever they are not followed by S or P. For example, *zi-* is glossed as SM10, which means that it is a subject marker that refers to/agrees with a class 10 noun. When the numbers 1 or 2 and S or P appear in the gloss, the morpheme refers to first or second person singular or plural. For example, *-ni-*, the object marker for first person singular, is glossed as OM1S.

In a Bantu language with multiple past tenses or future tenses, such as Haya, the relevant tenses are commonly numbered. In this kind of system, past 1 is closer to the speech time than past 2 and past 3.



---

## Abbreviations

---

/ high tone (above a vowel)	<b>CAUS</b> causative
\ low tone (above a vowel)	<b>CJ</b> conjoint
! downstep	<b>CONT</b> continuous
* ungrammatical sentence or impossible reading	<b>CONS</b> consecutive tense
✓ possible reading	<b>COP</b> copula
# sentence is inappropriate in the context indicated	<b>DAT</b> dative
% not all speakers accept the sentence as grammatical	<b>DEM</b> demonstrative
? degraded grammaticality	<b>DIC</b> Defective Intervention Condition
?? severely degraded grammaticality	<b>DJ</b> disjoint
<b>ACC</b> accusative	<b>DO</b> direct object
<b>Adj</b> adjunct	<b>DOC</b> double object construction
<b>AN</b> animate or animacy feature	<b>EPP</b> Extended Projection Principle
<b>APPL</b> applicative	<b>F</b> feature
<b>ASSOC</b> associative	<b>FCA</b> first conjunct agreement
<b>ASP</b> aspect	<b>FEM</b> feminine
	<b>FOC</b> focus marker
	<b>FUT</b> future
	<b>FV</b> final vowel
	<b>hum</b> human

<b>IAV</b> Immediate After Verb (position)	<b>POSS</b> possessive
<b>iF</b> interpretable feature	<b>PREF</b> prefix
<b>IMP</b> imperative	<b>PRES</b> present tense
<b>INF</b> infinitive	<b>PROG</b> progressive
<b>Inst</b> instrumental	<b>PRT</b> particle
<b>IO</b> indirect object	<b>REC</b> reciprocal
<b>LOC</b> locative	<b>REFL</b> reflexive
<b>MD</b> mood	<b>REM</b> remote past
<b>NC</b> noun class	<b>RM</b> relative marker
<b>NPST</b> near past	<b>S</b> (person) singular
<b>NEG</b> negation	<b>S</b> subject
<b>num</b> number	<b>SCA</b> second conjunct agreement
<b>OM</b> object marker	<b>SG</b> singular
<b>P</b> (person) plural	<b>SIT</b> situative
<b>PASS</b> passive	<b>SM</b> subject marker
<b>PCC</b> Person Case Constraint	<b>spec</b> specifier
<b>per</b> person	<b>SUBJ</b> subjunctive
<b>PRF</b> perfect	<b>TNS</b> tense
<b>PERF</b> perfective	<b>uF</b> uninterpretable feature
<b>PL</b> plural	<b>V</b> verb

# CHAPTER 1

---

## Introduction

---

This dissertation examines the morphosyntactic properties of object markers in the Bantu language Smbaa, and the Bantu languages more generally. An object marker is a morpheme which appears attached on the verb stem, usually in the form of a prefix. When discussing object agreement in Bantu languages, the agreement is expressed by the object marker.

Object marking patterns across Bantu are diverse: some Bantu languages have one object marker, others have several. Some require object markers with certain kinds of objects, whereas in others, object-marked objects apparently need to be dislocated. This kind of variation has given rise to a sizable literature on object marking in Bantu. However, to date there are no detailed typological studies nor truly in-depth studies of the syntax of object marking in particular Bantu languages. The goal of the present study is to address this gap. Swahili and Haya, two Bantu languages with object marking patterns that are substantially different from the pattern found in Smbaa, are compared to Smbaa through a range of construction types.

One of the key questions in the literature is the syntactic status of Bantu object markers as agreement markers or pronouns. It has been argued that there are two types of Bantu languages: those with pronominal object marking and those with object agreement. In this thesis, this dichotomy is rejected based on the three languages discussed in detail and evidence from a range of other Bantu languages. The strongest possible conclusion from that would be that all Bantu languages have object agreement. However, there are more than 500 Bantu languages, most of which are inadequately described at best. Some Bantu languages do not have any kind of object marking, while others might have different object marking patterns from Haya, Smbaa and Swahili. The conclusion here, then, is that the three languages discussed have object agreement, and that this analysis is extendable to other Bantu languages with the same

fundamental syntactic properties. And even though other languages may require different analyses from the one developed here, the in-depth investigation of these three language demonstrates that a simple two-way divide cannot be maintained.

Beyond the narrow issue of the syntax of object markers, this thesis touches on questions such as freedom of word order, microvariation, syntactic relations within the sentence and on how different areas of Bantu syntax are connected, or not. In the context of object marking, languages with varying degrees of word order freedom are discussed. It is shown that this property cannot be associated with Bantu in general, and that it is not always affected by object marking. A number of morphosyntactic patterns are discussed which show that even amongst Bantu languages belonging to the same sub-groups a lot of syntactic variation is found. Lastly, it is shown that a number of properties which are associated in the literature, only co-occur in some Bantu languages.

Agreement phenomena have been of interest to syntacticians working in different frameworks for a long time. This does not come as a surprise seeing how agreement phenomena illustrate how the most basic elements of a sentence interact and connect, and how the core meaning of a sentence is encoded. Cross-linguistically, subject agreement is more well-studied than object agreement, while languages with object agreement for more than one object, as discussed here, are rare. Moreover, where languages mark two objects on the verb this is generally not analysed as agreement. The data presented here challenges this notion. Finally, the Minimalist theory of Agree is based on subject agreement patterns, and as I argue here, it can be improved by considering object agreement as well. This is because object agreement, especially with more than one object, can elucidate locality effects and interference effects in ways which subject agreement cannot.

Sambaa particularly lends itself to an investigation of these questions because it has a range of syntactic properties which are not commonly assumed to co-occur in Bantu. It allows multiple object markers while at the same time showing clear animacy effects, and it has a restrictive word order. Swahili is one of the most widely studied Bantu languages and is generally assumed to have object agreement. Its syntax is rather similar to Sambaa, but Swahili allows only one object marker. Haya, finally, allows multiple object markers and has no animacy effects and a high degree of freedom of word order. In combination, these languages can offer insight into the extent of microvariation in Bantu and into the syntax of the Bantu languages as a whole.

## **1.1 The topic of this thesis**

In Sambaa, in a transitive or ditransitive construction, the verb may agree with one or more objects as well as with the subject. This is optional in most cases, but sometimes object marking is either obligatory or ungrammatical. Although it is often optional, object marking is a highly constrained syntactic process in this language. This thesis analyses how this process works.

Consider the example in (1). Object marking is obligatory in (1a) and optional in (1b).

- (1) a. Mbegha a- za- \*(mw-) ona Buge.  
 1Mbegha SM1- PERF.DJ- OM1- see 1Buge  
 ‘Mbegha saw Buge.’<sup>1</sup>
- b. Mbegha a- za- (mw-) ona ng’wanae.  
 1Mbegha SM1- PERF.DJ- OM1- see 1child.POSS.3S  
 ‘Mbegha saw his child.’ [Sambaa]

In (1), the object marker corresponds to the direct object of a simple transitive verb. With a ditransitive verb, agreement with the direct object is ungrammatical in the equivalents to both (1a) and (1b), shown in (2a) and (2b). However, when the indirect object is object-marked, as in (2c), object marking the direct object is possible but optional.

- (2) a. \* Mbegha a- za- u- nka Buge uzumbe.  
 1Mbegha SM1- PERF.DJ- OM14- give 1Buge 14kinghood  
 Int: ‘Mbegha gave Buge the kingdom.’
- b. \* Mbegha a- za- u- nka ng’wanae uzumbe.  
 1Mbegha SM1- PERF.DJ- OM14- give 1child.POSS.3S 14kinghood  
 Int: ‘Mbegha gave his child the kingdom.’
- c. Mbegha a- za- (u)- m- nka ng’wanae uzumbe.  
 1Mbegha SM1- PERF.DJ- OM14- OM1- give 1child.POSS.3S 14kinghood  
 ‘Mbegha gave his child the kingdom.’ [Sambaa]

This example illustrates two of the properties of Sambaa object marking which are discussed in this thesis: differential object marking patterns affected by animacy and definiteness, and the syntactic relations required for object marking to be grammatical.

## 1.2 Object marking across Bantu

Bantu languages are well-known for their agglutinative morphology. Especially the system of verbal inflections is rich. Bantu verbal complexes include morphemes which are co-referential with the subject and/or the object (or objects) of a verb. The status of these morphemes as agreement markers or pronominal clitics is disputed. This is primarily because Bantu languages allow *pro* drop for subjects and objects, and due to the fact that some Bantu languages have relatively free word order. This is illustrated with examples from Swahili. In (3a) *Juma* and *a-* refer to the subject (=Juma) and *wa-* and *watoto* ‘children’ both refer to the object. In (3b) the lexical NPs are dropped. In Swahili, free pronouns are used for contrastive focus, as shown in (3c). The free pronouns cannot receive a focus-neutral reading in this context.

<sup>1</sup>Mbegha is a famous chief from Sambaa folklore who became the first king of the Shambaa kingdom and passed the kingdom on to his son Buge.

- (3) a. Juma a- li- wa- ona watoto.  
 1Juma SM1- PAST- OM2- see 2child  
 ‘Juma saw (the) children.’
- b. A- li- wa- ona.  
 SM1- PAST- OM2- see  
 ‘He saw them.’
- c. Yeye a- li- wa- ona wao.  
 s/he SM1- PAST- OM2- see they  
 # ‘S/he saw them.’ (acceptable with contrastive focus) [Swahili]

Object markers have visible person and number features, or noun class features, but do not show any particular objective case, such as dative or accusative case. In the majority of Bantu languages there is no case marking on nouns either.<sup>2</sup> By and large, object markers have the same morphological shape as the corresponding subject markers and are distinguished from those based on their position in the verbal template and they have different tone patterns, where the tones of the subject markers often depend on the tense as well. Depending on the language there are morphological distinctions in some classes, usually class 1 and for second person.

There is a rather extensive literature dealing with object marking in individual Bantu languages, particularly on Swahili (Amidu 2006; Bukuru 1998; Seidel and Dimitriadis 1997; Wald 1979, 1997, 1998), but also on languages like Chichewa (Bresnan and Mchombo 1987), Sesotho (Demuth and Johnson 1990; Morolong and Hyman 1977), Rundi (Bukuru 1998), and Ruwund (Woolford 2001).<sup>3</sup> There is very little literature dealing with Bantu object marking in a wider comparative perspective, with two important exceptions. The first is Beaudoin-Lietz et al. (2004), which is a typological study of the distribution of object marking across Bantu. The second is the research reported in Marten et al. (2007) and Marten and Kula (2008). Marten et al. (2007) and Marten and Kula (2008) examine a range of morphosyntactic parameters related to Bantu object marking based on a sample of 12 languages, showing how much diversity there is in this area of Bantu syntax.

**The typology of Bantu object markers** Beaudoin-Lietz et al. (2004) discuss the number of object markers and the position of the object marker with regard to the verb stem across the Bantu family. They divide the Bantu languages into three groups: type 1, which has prestem object marking; type 2, which has postfinal object marking; and type 3, which has both prestem and postfinal object marking. The predominant pattern is to have the object marker(s) before the verb-stem, as shown in (4a). This pattern is found in the languages spoken in the northeast, southeast and south of the Bantu speaking areas. A geographically more restricted pattern is having only postverbal object marking, as shown in (4b). This is found amongst Bantu languages spoken in Cameroon and neighbouring countries. A third group has both prestem and postfinal object marking, as shown in (4c) (Beaudoin-Lietz et al. 2004).

<sup>2</sup>Some (south)-western Bantu languages are argued to have so-called tone case (Schadeberg 1986). However, these do not behave like nominative-accusative or ergative-absolutive case systems.

<sup>3</sup>All the data in Woolford (2001) is from Nash (1992).

- (4) a. Type 1: prestem object marking:  
 U- li- ni- ona.  
 SM2S- PAST- OM1S- see  
 ‘You saw me.’ [Swahili]
- b. Type 2: postfinal object marking:  
 Go á si bee me.  
 you PAST2 PFV see me  
 ‘You saw me.’ [Konzime, Beaudoin-Lietz et al. 2004:183]
- c. Type 3: prestem and postfinal object marking:  
 N- a- mw- ink- á- wu.  
 SM1S- PAST2- OM1- give- FV- OM3  
 ‘I gave him it.’ [Lunda, Beaudoin-Lietz et al. 2004:184]<sup>4</sup>

Most Bantu languages allow at least one object marker. The languages discussed in this dissertation are of type 1. In a number of places, I refer to Nash’s analysis of Ruwund, some dialects of which are of type 3. Most of the object marking data in Nash (1992) is from a dialect of Ruwund, namely Musumban Ruwund, which allows several object marking prefixes, rather than suffixes. In one part of this dissertation, I discuss double object constructions in the Grassfields language Limbum. This Semi-Bantu language has the pattern which is described as type 2 in Beaudoin-Lietz et al. (2004). However, I do not follow their morphological classification system for this language, but treat it as a language without object marking. This is also how other researchers analyse Bantu languages in zone A (Mark van der Velde, p.c.).

Another problem with classifying the attachment site of the object marker is that in the Lacustrine (the languages spoken around Lake Victoria) Bantu languages (zone J/D), but not only in this group, locative object markers can be suffixed to the verb, while any other object markers are prefixed. This is the case in some dialects of Haya as well. The suffixed object markers tend to have a different shape from the prefixed object markers, looking more like relative pronouns. I have nothing to say about these kind of morphemes here because my Haya informant did not use these kinds of suffixes, or judge them as grammatical. In how far these kinds of markers are similar or different from prestem object markers is a matter for future research.

The majority of the languages in the Bantu language family allow only one object marker, but a small group of Bantu languages allow several. It is not clear if there are real restrictions on the number of object markers in languages which allow more than one (Marten et al. 2007). The exceptions to this are Nyaturu (Rimi) (Hualde 1989) and Bemba (Marten et al. 2007), which only permit a second object marker in very restricted environments, namely the first person singular nasal can co-occur

<sup>4</sup>“Lunda” and “Ruwund” are sometimes used interchangeably to refer to Ruwund (Ruund), a language discussed in chapter 3. Ruwund is classified as L53 in Maho (2008). The language referred to as Lunda in Beaudoin-Lietz et al. (2004) is a Zambian language (L52) closely related to Ruwund but not mutually intelligible with it (Nash 1992).

with other object markers.<sup>5</sup> Most languages with multiple object marking allow two or three object markers to co-occur, but more complex forms are rare. Beaudoin-Lietz et al. (2004) give an example of six object markers from Rwanda, as shown in (5). The order of object markers is not flexible in the vast majority of Bantu languages. One exception to this is Tswana (Marten et al. 2007).<sup>6</sup>

- (5) Umugoré a- ra- na- ha- ki- zi- ba- ku- n-  
 1woman SM1- FOC- ALSO- OM16- OM7- OM10- OM2- OM2S- OM1S-  
 someesheesherereza.  
 read.CAUS.CAUS.APPL.APPL  
 ‘The woman is also making us read it (book) with them (glasses) to you for  
 me there (in the house).’

[Kinyarwanda, Beaudoin-Lietz et al. 2004:183]

### 1.3 Concepts and terminology

**The term “object marking”** “Object marker” in this thesis refers to a type of morpheme attached to the verb, which in Bantu linguistics is called the “object marker”, “object concord”, or “object pronoun”. Of these terms, “object marker” is the most neutral. This use of the term, and the related “object marking”, within Bantu linguistics is somewhat different from the way the term is used by linguists working on Indo-European languages and other language families, where “object marking” refers to case marking on the noun. There is a considerable literature on “differential object marking”, which refers to morphological case marking which appears only on a subset of nouns which have that case (Aissen 2003; Bossong 1985; de Hoop and Lamers 2006; Malchukov 2008). The syntactic patterns involved are extremely similar to object marking in a number of Bantu languages, so that there is no reason not to use the term to also cover the similarly restricted appearance of object markers on a verb in Bantu.

**Objects in Bantu** In the literature on Bantu, it is sometimes questioned whether certain Bantu languages have double object constructions at all, because the two potential objects differ greatly in their syntactic behaviour. Beyond that, doubts have even been

<sup>5</sup>There are counter-claims to this for Nyaturu. According to Olson (1964), Nyaturu allows two object markers. He does not mention any restrictions on which objects they can refer to. However, his two examples both involve the first person singular, as shown in (1).

- (1) W- u- nj- aruma utako  
 SM2S- OM14- OM1S- lend 14bow.your  
 ‘You lend me your bow.’

[Nyaturu, Olson 1964:172]

<sup>6</sup>Interestingly, this verb form has the object marker *-ba-* (class 2), where *-tu-* (1st person plural) would be expected (Meeussen 1959:102). This may be an effect related to the Person Case Constraint, which rules out certain combinations of person marking. In this case there are two potential indirect objects. Person Case Constraint effects in Samba and other Bantu languages are discussed in chapter 5.

raised as to whether Bantu has objects, and if so how they may be identified. This is because there is no overt case marking or any other morphological marking on the object noun phrase which could distinguish objects from adjuncts. Moreover, in Bantu, adjuncts, locative phrases and other non-arguments often appear as bare nouns (insofar as not being introduced by a prepositional phrase or determiner), just like objects. Certain types of objects can also be dropped without being agreed with or pronominalised when they are identifiable from the discourse.

There are three properties which are generally used to distinguish between objects and other postverbal noun phrases in Bantu languages: the ability to trigger object marking on the verb, the ability to appear in the immediately postverbal position and the ability to passivize (Hyman and Duranti 1982; Schadeberg 1995; Thwala 2006). These tests have been criticised for producing contradictory results in Schadeberg (1995) and Thwala (2006). Schadeberg (1995) proposes additional properties to use for certain Bantu languages, while Thwala (2006) argues that Bantu languages do not have objects but only complements and adjuncts. The main problem identified in the literature is that the class of entities which can appear in the position immediately following the verb is not restricted to objects, while, in some Bantu languages, locatives can be object-marked as well.

In some Bantu languages, only one object in a double object construction meets these criteria; in others, both do. Double object constructions in Bantu are often applicative or causative constructions. Many Bantu languages have only one non-derived ditransitive verb, namely a verb which translates as 'to give'. There are three relevant argument structural configurations for the double object constructions in the languages discussed here: verbs meaning 'give', transitive verbs with an applicative extension, and transitive verbs with a causative extension. Based on their behaviour with regard to the three properties listed above, Bantu languages are frequently labelled as being "symmetric" and "asymmetric" Bantu languages, following Bresnan and Moshi (1990), although more tests are discussed in the original article. In Bantu studies, the labels "primary object" and "secondary object" are sometimes used to refer to the two complements in a double object construction when speaking of asymmetric languages, such as Ruwund or Swahili, where the primary object is the one which meets the object criteria and the secondary object is the one which does not. The primary object corresponds to what is called the "indirect object" in the wider linguistic literature and the secondary object to the "direct object" in a double object construction.

In my view, the Bantu languages discussed here have two objects. These objects have six relevant properties: they are noun phrases (not prepositional phrases); they are reflected in the morphological argument structure of the verb; they appear adjacent to the verb (unlike temporal adjuncts, locatives and similar entities), potentially in a fixed order (as in Sambia); they are required either to be overtly expressed or to be present in the discourse context (in a way in which adjuncts are not); they can be object-marked under the right conditions; and they can be object-marked under the right conditions. However, all objects are not equal. In asymmetric languages only the primary object/indirect object can be passivized. Depending on the language, this object may also be required to immediately follow the verb, and to be object-marked

before the direct object can be object-marked. These properties are illustrated and discussed throughout this thesis.

I will use the terms “indirect object” and “direct object” rather than “primary” and “secondary” object. The object which I refer to as the “indirect object” has the role of the goal, recipient or benefactive argument of a ditransitive verb, while the direct object is the theme argument.<sup>7</sup> This choice of terminology seems preferable because in Haya, one of the languages discussed more extensively here, based on the three tests, there is no difference between the two objects. Nevertheless, the two objects are not equal, because there is a basic unmarked word order where the indirect object precedes the direct object. Moreover, I approach agreement from a Minimalist perspective. The way double object constructions are treated in this framework, following Larson (1988, 1990), predicts asymmetries between the two arguments based on their attachment site and the resulting differences in scope and hierarchical relations. This is because the direct object is the sister of V and the indirect object is in the specifier position of VP, as shown in (6). This means that the indirect object will be closer to any Probe located above VP and asymmetrically c-command the direct object. These asymmetries predicted by the Larsonian structure match the pattern found in asymmetric Bantu languages including Swahili, Ruwund and Sambiaa.

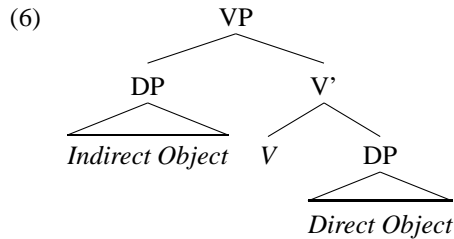

In a simple transitive clause, as in (7), the direct object is the highest object. This predicts that the properties of the direct object in a simple transitive clause and the indirect object in a ditransitive clause are comparable. For Sambiaa, this is indeed what we find. For Haya, this structure matches the basic word order. The implications of this structural difference on object marking are discussed in chapter 4.

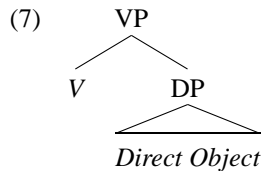

## 1.4 Languages discussed

This thesis primarily seeks to analyse object marking patterns in Sambiaa (Shambala, G23). A linguistic introduction to this language is provided in chapter 2. In order

<sup>7</sup>This kind of terminology is also used by other Bantuists, for example in Bearth (2003).



Figure 1.1: Location of Bantu languages discussed

to achieve a deeper understanding of object marking patterns in a variety of Bantu languages, the Smbaa data is compared to Haya (J 22) and Swahili (G42) throughout. Smbaa and Haya are also compared in the other literature which touches on the issue of object marking in Smbaa (Baker 2008; Duranti 1979; Hyman and Duranti 1982). All three languages are spoken in Tanzania. The map in 1.1 shows the approximate location of Haya, Swahili and Smbaa, as well as that of some of the other Bantu languages discussed in this thesis.<sup>8</sup>

### 1.4.1 Data collection

The Smbaa data used in this thesis was collected in Lushoto and surrounding villages from January through June 2005, and with Smbaa speaking students at the University of Dar es Salaam during April and June 2005, from August through December 2006 and in Leiden in September and October 2007. Many of the stories were recorded during a week spent in Sunga, near Mtae village in 2005, and in and

<sup>8</sup>This map an adaption of: Africa map political (Eric Gaba 2009). Distributed under a Creative Commons Attribution License.

around Lushoto in 2005 and 2006. Data was collected in the form of judgements on Smbaa sentences, translations from Swahili or occasionally from English to Smbaa, in informal interviews, as well as by recording and transcribing narratives, and to a limited extent conversations. More than 6.5 hours of narratives (natural, spontaneous speech) were recorded using an MP3 recorder of which about 3000 utterances were transcribed using ELAN (an open source software created at the Max Planck Institute Nijmegen). These narratives included traditional stories, picture stories like the *Frog Story*<sup>9</sup>, historical narratives, family histories, instructive narratives (related to things such as farming) and conversations. Beyond those, several thousand sentences were elicited to illustrate Smbaa object syntax.

The main group of Smbaa speakers involved in the project consisted of males and females in their late 20s and early 30s. Stories were recorded and some judgements elicited from a larger group which included much older speakers as well, the oldest of whom was said to be more than 90 years old. Speakers were from the Lushoto area, as well as Mtae and Mlalo. All were bilingual in Smbaa and Swahili, several also spoke English and some had some knowledge of Pare. Some informants attended university, while others only had a basic primary school education.

The data on Haya was collected primarily in the Netherlands with a speaker of the Bugabo dialect. Again, this speaker was bilingual in Swahili and Haya. The Swahili data was collected in Dar es Salaam with speakers from different parts of Tanzania with a variety of linguistic backgrounds, including monolingual Swahili speakers from Zanzibar (Stone Town) and the Tanzanian mainland.

## 1.5 Theoretical background

This thesis discusses the syntax of object marking from a Minimalist perspective. In this section, I introduce some of the key concepts required to follow the discussion of object marking. The most important part is the concept of *Agree*. The current Minimalist approach is based on Chomsky (2000, 2001). *Agree* is a feature-checking relationship between two elements: the *Probe* and the *Goal*. *Agree* is defined as in (8), following Chomsky (2000, 2001).

- (8) **Agree:** A relationship between a Probe and a Goal, established under c-command.

For object agreement, the Probe is the agreement morpheme or potentially a verbal head, and the Goal is the object noun phrase. The relationship between the Probe and the Goal is asymmetric. In Minimalist syntax, this is explained based on the existence of two types of features: interpretable features and uninterpretable features. Uninterpretable features need to be checked during the course of a derivation before reaching the level where semantic interpretation takes place (LF). A Probe has an uninterpretable feature which needs to be checked with an interpretable feature of a matching type. To find a matching feature, the Probe will search its c-command domain for

---

<sup>9</sup>*Frog, where are you?* (Mayer 1969).

a suitable Goal. The c-command domain of an element are the elements which are dominated by the first node which dominates this element. This is illustrated in (9), for X the first element which dominates it is XP. Therefore, the c-command domain of X is YP and all its subparts.

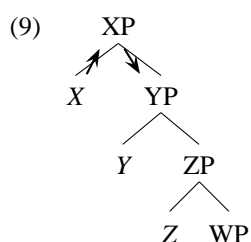

Uninterpretable features are features such as structural case or  $\phi$ -features. The process by which these features are checking is called ‘matching’ in Chomsky (2000:122). In this model, Agree requires Match, which is defined in (10), where P stands for Probe and D(P) is the domain of the probe, namely the area it c-commands.

- (10)
- a. Matching is feature identity.
  - b. D(P) is the sister of P.
  - c. Locality reduces to “closest c-command”.

Unlike earlier approaches to agreement, such as the spec-head agreement hypothesis (Kinyalolo 1991), for Agree, movement is not required. However, Agree is subject to a locality condition: closest c-command.

- (11) **Closest c-command:** Closest c-command holds between a Probe X and a Goal Y if there is no potential Goal Z which contains Y.

Closest c-command is particularly important with object agreement. Any clause has only one subject, but for object agreement there are often several options and, in fact, in some Bantu languages, several objects may agree. This is discussed in detail in chapter 4.

## 1.6 Overview of the thesis

The thesis is structured as follows. Chapter 2 introduces Smbaa. The basic properties of the language are illustrated, including noun classes, the phonological inventory of the language and its basic verbal morphology. The morphosyntactic properties which are important to the topic of this thesis are introduced and illustrated. The last section introduces some properties of Smbaa that are atypical in Bantu.

Chapter 3 discusses object marking patterns across Bantu. The focus of the discussion are the properties which might characterize object marking as pronominal

incorporation or agreement for a particular language. Sambiaa and Haya are examined in detail. Other languages are introduced for comparative purposes. The right-dislocation analysis for object-marked objects is discussed for Haya. It is argued that object-marked objects in this language do not have to be right-dislocated. Haya and Sambiaa are shown to have very different object marking systems. It is argued that, in spite of those morphosyntactic differences, object marking is syntactic agreement in both languages.

Taking the conclusions from chapter 3 as a starting point, chapter 4 discusses the theoretical concept of Agree and how Sambiaa object marking fits current theoretical approaches to Agree. It is argued that a very minimalist Agree mechanism can account for the Sambiaa data. Haya object marking is more challenging. But as is shown, the Agree approach has advantages compared to the pronominal analyses here too. Swahili is used as a third case study to illustrate how object marking in Bantu can be treated in terms of Agree.

Chapter 5 discusses Person Case Constraint (PCC) effects in Bantu. PCC effects are shown to work in the same way across across Bantu, irrespective of the number of object markers a language allows and other morphosyntactic parameters. Bantu languages are shown to obey the weak PCC, but not the strong PCC. It is shown that the PCC effects in Bantu cannot be explained by a ban on person agreement or a requirement for person features to undergo movement in order to be checked.

Chapter 6 discusses object marking in *wh*-contexts. It is shown that animacy plays a decisive role in determining object marking patterns in Sambiaa *wh*-questions. The position of *wh*-elements in Sambiaa is discussed. It is argued that *wh*-elements undergo movement to the IAV (Immediately After the Verb) position. The structure of relative clauses is also discussed. Unlike Sambiaa, Haya never allows object marking in *wh*-contexts. It is argued that this is because, in Haya, object marking is only possible for specific objects. Unlike in languages like Turkish and Persian, object marking is not required for all specific or definite objects.

Chapter 7 discusses object marking with coordinated noun phrases. The properties of coordinated subjects and coordinated objects are compared. It is shown that agreement patterns differ depending on the position of the coordinated noun phrase with regard to the verb. Preverbal coordinate structures require full agreement while postverbal coordinate structures also allow partial agreement. This provides further support for the analysis of object marking argued for in this thesis. Sambiaa and Haya only allow first conjunct agreement with postverbal coordinate structures. Swahili has marginal second conjunct agreement as well. These patterns are discussed with reference to theoretical analyses of coordination agreement.

Chapter 8 concludes this discussion and highlights some issues for further research related to Sambiaa object marking.

## CHAPTER 2

---

### Notes on Smbaa

---

This chapter introduces the Smbaa (Shambala) language. Section 2.1 gives information on where Smbaa is spoken, its classification, current status and use. Section 2.2 gives a short overview of the literature on Smbaa. Section 2.3 introduces some of the basic grammatical properties of Smbaa, to enable the reader to fully understand the data used in subsequent chapters and highlights some of the properties of Smbaa which are less typical for Bantu languages spoken in that area or altogether uncommon.

### 2.1 Classification and geographic location

Smbaa is a Bantu language from the Northeast Coastal Bantu Group (Nurse et al. 1981). Smbaa is classified as G23 by Guthrie (1971). Guthrie's G20 group also includes Asu (Pare), Bondei and Taveta. Asu and Bondei are spoken by the immediate neighbours of the Smbaa. The other languages spoken by neighbouring communities are Ngulu and Zigula, which are in the G30 group; as well as Digo (E73) (Mwalonya et al. 2004), Swahili (G42), Maasai, Mbugu and Dhaiso. Mbugu, Maasai and Dhaiso are very different from the other languages of the area. Dhaiso is most closely related to the Central Kenya Bantu languages (Nurse 2000), and Mbugu is a "mixed language" with Bantu and Cushitic origins (Mous 2003b). Maasai is a Nilotic language. A map of Smbaa and its neighbouring languages is shown in 2.1.

According to a lexicometric comparison cited in Gordon (2005), Smbaa has 75% 'lexical similiary' with Bondei, and 68% with Ngulu and Zigula.<sup>1</sup> Beshu (1989b) presents somewhat different statistics, which she attributes to Nurse and Philippon

---

<sup>1</sup>These numbers are based on comparisons of lexical items on a short Swadesh-style word list.

(1975). Nurse (2000) groups Sambia with Bondei, Zigula (Zigua) and Ngulu in linguistic group he labels as “Sheuta”.

Sambia is spoken by the Sambia people (*washambia*) who live in two mountain ranges: the Eastern and Western Usambara Mountains. This area includes the Lushoto district and parts of the Muheza and Korogwe districts, all of which belong to the Tanga region in the north-east of Tanzania. Sambia is estimated to have between 550,000 and 650,000 speakers. The Languages of Tanzania (LOT) project calculates that Sambia has 565,276 speakers (Rugemalira and Muzale 2008), while Johnstone and Mandryk (2001) estimate it to have as many as 664,000 speakers. The LOT figure places Sambia amongst the 15 biggest languages of Tanzania in terms of speaker numbers. However, data on the number of speakers of Tanzanian languages are relatively unreliable since the official census neither includes questions on ethnic group nor on languages spoken (Rugemalira and Muzale 2008).

Traditionally, the Sambia people are farmers. There are a number of anthropological studies of the Sambia history, customs, indigenous political systems, and healing traditions (Feierman 1974, 1990). The Sambia refer to the area where they live as *Shambalai*. This area is understood to refer to the mountains, as opposed to the plains, which are called *nyika* by the Sambia people. I refer to the language as “Sambia” here. Alternative names for it are: “Shambala” (the spelling variant “Schambala”) or “Shambia”. The noun class prefix *ki-*, class 7, which is used in Sambia with nouns referring to languages, can appear with any of these variants. In Tanzanian English, this usage is particularly common, due to influence from Swahili. In Sambia, the language is referred to as *kishambia*. However, when Sambia speakers speak Swahili, they refer to their language as *kisambia*.

**Dialects** There are apparently no major lexical or grammatical differences between Sambia dialects, but to date no detailed studies have been carried out on this. Besha (1989b) mentions three dialects: Lushoto, Mlalo and Korogwe. One noticeable difference between Sambia speakers from different areas is the disappearance of intervocalic and word-initial /l/. This is very pervasive in Lushoto Sambia, while Mtae and Mlalo speakers tend to retain the /l/.

**Language use** Sambia is used widely in informal contexts, even outside of the Sambia speaking areas. It is the dominant language in Lushoto District, where there are also clusters of Asu (Pare) speakers and Mbugu (Ma’a) speakers who are generally multilingual in their language, Sambia and Swahili (Mous 2003b). According to Nurse (2000), the Dhaiso people, who live in several villages in the easternmost part of the Sambia speaking area, generally claim not to speak Sambia. But, according to Nurse (2000), at least a number of them do, while Sambia speakers generally do not speak Dhaiso. The Sambia children I had contact with, who grew up in Usambara, were monolingual, or at least without an active knowledge of Swahili, until they started primary school. Swahili, however, is heard frequently not only in Lushoto but even in small and relatively remote villages. All the adult Sambia speakers I encountered were bilingual in Sambia and Swahili. Following government policy since independence,

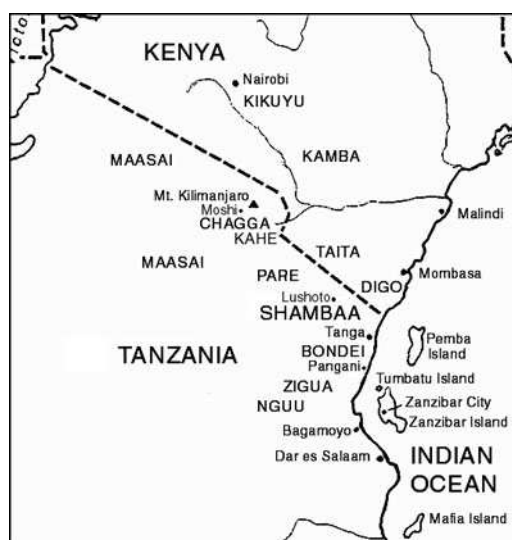

Figure 2.1: Smbaa and neighbouring languages (©Barbara Thompson 1998. Reproduced by permission.)

Smbaa is not used in education or in other official contexts. There are no newspapers or radio broadcasts, nor are books currently being published in the language. Under Tanzanian government policy, use of ethnic community languages in media, education or electoral campaigns is actually prohibited. Children will be punished for speaking ethnic community languages in primary schools (Rugemalira and Muzale 2008).

There is a translation of the New Testament into Smbaa (The Bible Society in Tanzania 1969), as well as a book of hymns and a small number of other texts. These are not currently available, except for the New Testament and the book of hymns which can be found in one bookshop in Lushoto town. During the German colonial era, primary school primers in Smbaa were used. These seem to have disappeared from circulation altogether. However, efforts are underway to republish one of those texts, which is a lengthy collection of Smbaa stories and their Swahili translations Tulleman (2006). As Smbaa has no official status or function in the education system there is no standardised orthography. In this thesis, I use a slightly simplified version of the orthography developed by German missionaries in the early 20th century for all the Smbaa examples. This is the way Smbaa speakers write their language and which is used in the existing books in Smbaa and is adequate for distinguishing the phonemes.

## 2.2 Literature

The most extensive linguistic description of Smbaa is Roehl (1911), a tone-marked descriptive grammar of Smbaa written in German. Roehl was based at the Bethel Mission in Usambara for 12 years (1886-1908). The Bethel Mission had a number of mission stations around Usambara, including Mtae, Mlalo, Vuga and Bumbuli, as well as Tanga (on the coast outside of the Smbaa speaking areas). It is not clear at which of these places Roehl collected his data. He names a key informant for tones in the preface of his book but does not state which part of Usambara this informant comes from. During his time in Usambara he worked on describing and analysing the language and translating the New Testament into Smbaa. According to Odden, Roehl's grammar made Smbaa one of the first Bantu languages to have published information on tones (Odden 1982). Roehl's book also includes some traditional stories which are tone-marked and translated. But the tone-marking system he uses differs from modern usage, as found in work by modern scholars such as Odden (1982) and Nurse (1979). Roehl has four level tones, whereas Odden (1982) analyses Smbaa as having two level tones, which are modified by processes such as downstep and downdrift. The Smbaa language as Roehl describes it is very similar to current Smbaa. However, I could find no traces of his class 11 (lu-) with any of my Smbaa language consultants. Words which Roehl puts into class 11, appear in class 14 in current Smbaa. Roehl has lists of very complex verbal patterns, and some applicative forms which were not judged as acceptable by my speakers. I never came across most of his tense-aspect forms during my fieldwork. Combinations of several tense-aspect markers did occur in natural speech but were extremely rare. His list of auxiliaries was different from the ones I noticed amongst my data. This might be due to language change. In any case, his translation of the New Testament into Smbaa is considered an example of great eloquence by the Smbaa speakers I worked with.

Ruth M. Besha produced a number of works on different aspects of Smbaa grammar, focussing mostly on tense. Her PhD thesis, which was subsequently published by Reimers, deals with tense-aspect marking in Smbaa (Besha 1985, 1989b). She has also published a "classified vocabulary" which contains some grammar notes (Besha 1993), an article on Smbaa relative clause formation, written in Swahili, (Besha 2000), and an article on mood in African languages which discusses Smbaa (Besha 1989a).

Other sketches of Smbaa grammar include Nurse (1979) and Steere (1867). Nurse (1979) sketches the phonology, noun classes and tense-aspect markers of Smbaa. Steere (1867) is based on data which does not appear to be Smbaa for the most part, rather than some other coastal Bantu language. The data was collected in Zanzibar.

There is one dictionary of Smbaa, apart from the vocabularies by Besha (1993) and Yukawa (1984). This is a Smbaa-German dictionary produced during colonial times (LangHeinrich 1921). This dictionary is a good resource with many examples of language usage and its entries are often illustrated with idioms, but it does not include tone marking. Yukawa (1984) is a "classified vocabulary" in Smbaa, English, Swahili and Japanese with grammatical notes written in Japanese.

Regarding the phonology, there are a small number of articles which primarily deal with Smbaa. Odden (1982) gives an overview of tonal phenomena in Smbaa. His data is based on what he refers to as an “eastern” dialect. Odden also notes the absence of class 11 in his data. He attributes this to potential dialect differences between this dialect and Roehl’s data. My data was collected from speakers of Smbaa from the Western Usambara mountains, yet there were no differences between Odden’s examples and my data. Meeussen (1955) is an analysis of the diachronic development of a particular tone pattern in current Smbaa. Van Spaandonck (1967), Kähler-Meyer (1962) and Philippson (1991) also deal with Smbaa tonology.

Smbaa morphosyntax is discussed in Dammann (1954) and Duranti (1979). Dammann (1954) discusses reciprocals and statives in Smbaa and Swahili. Duranti (1979) compares object marking in Haya and Smbaa. His data on instrumentals, the number of object markers allowed, and on acceptable combinations of first and second person object markers differ from mine. A number of pronominal forms in his article are Swahili forms which I have never found in Smbaa and which were rejected by my informants, as not being Smbaa forms. Duranti’s Smbaa data is widely cited in the typological and theoretical literature (Baker 2008; Haspelmath 2004; Nurse and Philippson 2003; Siewierska 2004).

Mous (2003a) does not deal primarily with Smbaa. But he often refers to Smbaa where he discusses the similarities and differences between it and the neighbouring languages Mbugu and Asu (Pare). This resource is particularly useful, because it discusses a number of morpho-phonological phenomena not mentioned elsewhere.

## 2.3 Grammatical notes on Smbaa

This section provides a sketch of the basic phonological and morphosyntactic properties of Smbaa, including the sound system and some basic morphological properties and introduces the syntactic properties most relevant to understanding the Smbaa data and data from other Bantu languages discussed in this thesis.

### 2.3.1 Phonology

Smbaa has a five-vowel system, with the vowels: [a] [i] [ɛ] [o] [u]. There is no phonemic vowel length alternation. The vowel of the penultimate syllable of a word is lengthened in Smbaa (Odden 1982), for example the second [o] in *ogoha*, as shown in (1a), is long, but this is not marked orthographically. However, in words where an intervocalic /l/ has been deleted long vowels are found, as shown in (1b), which is reflected in the orthography using two vowels.

- (1) a. ku- ogoha  
 INF- fear  
 ‘to fear’

- b. ku- ikaa  
 INF- sit  
 ‘to sit/stay’

The consonant inventory is shown in (2.1). The IPA equivalents, where the IPA differ from the characters used here, are shown in (2.2).

Table 2.1: Consonant Inventory of Sambiaa

	labial	alveolar	palatal	velar	glottal
voiceless stop	p	t		k	
voiced stop	b	d		g	
voiceless affricate			ch		
voiced affricate			j		
voiceless fricative	f	s	sh		h
voiced fricative	v	z		gh	
sonorant		l			
glide	w		y		
nasal	m	n	ny	ng'	
voiced prenasalised stop	mb	nd	nj	ng	
voiceless prenasalised stop	mp	nt		nk	

Table 2.2: IPA equivalents of orthographic symbols used in this thesis

Orthographic	IPA
ch	[tʃ]
j	[j]
gh	[ɣ]
mb	[ <sup>h</sup> m̩b]
mp	[ <sup>h</sup> m̩p]
nd	[ <sup>h</sup> n̩d]
ng	[ŋg]
ng'	[ŋ]
nj	[ <sup>h</sup> n̩j]
nk	[ <sup>h</sup> n̩k]
nt	[ <sup>h</sup> n̩t]
ny	[ɲ]
sh	[ʃ]
y	[j]

There is some variation, apparently between speakers of the same dialect, with regard to the realisation of the voiceless prenasalised stops. Many speakers do not articulate the stops following the voiceless nasal, so that [nt] and [nk] can sound the very similar. Voiceless nasals predominately appear at morpheme boundaries, when

the class 9 prefix N meets a consonant. The contrast is illustrated by the pairs (2a/b) and (2c/d). Voiceless nasals can also appear inside lexical items such as *kùzìnkà* ‘to pass’ or *mntù* ‘person’.

- (2) a. /wantu wa- kuu/ > [wãntu wakuu]  
 2person 2- big  
 ‘big people’
- b. /nyumba n- kuu/ > [ɲu<sup>m</sup>ba ŋkuu]  
 9house 9- big  
 ‘big house’
- c. /mahagi ma- gheke/ > [mahagi mayɛkɛ]  
 6beans 6- small/few  
 ‘a few beans’
- d. /nkanga n- gheke/ > [ŋkãŋga ŋkɛkɛ]  
 9peanut 9- small/few  
 ‘unripe peanuts’

According to Besha (1989b), *l*-deletion is being reversed amongst younger speakers. I did not find this claim to hold, as none of the younger speakers from the Lushoto area that I worked with used /l/ in these contexts. However, throughout the Sambaa speaking area, /l/ is retained in the word *ghùlà* ‘buy’. This verb has the same tone pattern as the verb *ghùà* ‘take, marry’. But the sentences in (3a) and (3b) are not ambiguous. The verb *ghùà* ‘take, marry’ never has an /l/, even when used by speakers who retain /l/. This is the only instance of /l/ being distinctive which I came across in Sambaa.

- (3) a. Á- zà- ghùlà.  
 SM1- PERF.DJ- buy  
 ✓ ‘He bought.’  
 \* ‘He took/married.’
- b. Á- zà- ghùà.  
 SM1- PERF.DJ- take  
 ✓ ‘He took/married’  
 \* ‘He bought.’

In all of my data of Lushoto Sambaa (as opposed to the Mlalo dialect where it is *lélò*), /l/ is retained word-initially in *léò* ‘today’. According to my informants, there are speakers who drop the /l/ in this context but I did not come across instances of this myself. However, in other word-initial environments, /l/ is not retained. For example, *uvi* ‘chameleon’ (< /luvi/) or the name of the town “Lushoto”, which is *Usoto* in current Lushoto Sambaa. In verbs which might have been borrowed recently from Swahili, such as *kulala* ‘to sleep’ (Sambaa has *kugosha* ‘to sleep’) and *kuogelea* ‘to swim’ (Sambaa has *kuhaka* ‘to bathe’), /l/ is used. Here it is not acceptable to drop the /l/.

**Assimilation** The vowel of certain verbal extensions assimilates to the vowel of the verb root in terms of vowel height. For example, extensions such as the applicative *-IL-* are underspecified in terms of vowel height, with /a, u, i/ triggering an extension with an /i/ and /o, e/ triggering an extension with /e/. Assimilation also takes place with some nasals, for example the copula *ni* reduces to a nasal which is cliticised to the following word and assimilates with it in terms of its place of articulation, surfacing as a bilabial nasal when followed by a bilabial nasal (4a) or consonant (4b) and as an alveolar nasal when followed by any other consonant, as shown in (4c) and (4d).

- (4) a. m' mbwai  
       COP what  
       'is what'
- b. m' baba  
       COP 1uncle  
       'is uncle'
- c. n' ndayi  
       COP 1who  
       'is who'
- d. n' tate  
       COP 1father  
       'is father'

**Prosody** Sambia has two underlying tones: high (H) and low (L), as well as phonemic downstep (Odden 1982). As in the majority of Bantu languages, tones function to distinguish lexical items, as well as encoding inflectional (for example tense) and syntactic information (such as the distinction between a question and a statement). According to Odden (1982), Sambia has regular penultimate stress. He argues that this is expressed by lengthening the penultimate vowel, not by pitch raising.

### 2.3.2 Morphosyntax

**Noun classes** Bantu languages are renowned for their large number of gender categories: the noun classes. In Bantu linguistics, the noun classes are numbered systematically for all Bantu languages, following a numbering system proposed by Bleek (1862, 1869) and extended by Meinhof (1899, 1906) (Katamba 2003). Current Sambia has 17 noun classes. These are shown in table (2.3). In general, in the Bantu noun class system, singular and plural noun classes are paired, with all nouns that appear in one noun class in the singular appearing in one noun class in the plural. For example, the plurals of nouns in class 1 are in class 2, the plurals of nouns in class 3 are in class 4 and so forth. Odd numbers generally indicate singular noun classes while even numbers indicate plural classes. However, this system does not apply to the higher noun classes. In Sambia, any classes above class 10 do not fit this system. Words in class 12 are singular and have their plural forms in class 8. Nouns in class 14 frequently don't have a plural form for semantic reasons. When they do, the plural forms are usually in

class 10. Class 15 contains only infinitival verbs. Class 16, 17 and 18 are the locative classes.

For each nominal class, the nominal prefix (NC PREF), the subject marker (SM), the object marker (OM), the associative (ASSOC), and the three basic demonstrative forms (DEM1, 2 and 3) are shown.

The nominal prefix is attached to the noun stem, as well as to adjectives. The associative form is used in genitive constructions. The demonstrative series differ in their deictic and discourse function. The DEM1 series is used for proximate demonstrative meanings, the DEM2 series for previously mentioned entities, and the DEM3 series for distal meanings. But this is not their only use. The DEM3 forms are frequently used pronominally with previously introduced entities. There are a number of other forms which are derived from the ones listed here. Roehl gives a total of 7 demonstrative forms for each noun class, one set of which includes the negative copula *si* and two forms which involve different types of reduplication (Roehl 1911).

Table 2.3: Smbaa Noun Classes

	NC PREF	SM	OM	ASSOC	DEM1	DEM2	DEM3
1	m-	a-	-m-	wa	uyu	uyo	uja
2	wa-	wa-	-wa-	wa	awa	wao	waja
3	m-	u-	-m-	wa	unu	uo	uja
4	mi-	i-	-i-	ya	inu	iyo	ija
5	∅/ i-/ zi-	ji-	-ji-	ja	iji	ijo	jia
6	ma-	ya-	-ya-	ya	aya	ayo	yaja
7	ki-	ki-	-ki-	cha-	ichi	icho	chia
8	vi-	vi-	-vi-	vya	ivi	ivyo	viya
9	N-	i-	-i-	ya	inu	iyo	ija
10	N-	zi-	-zi-	za	izi	izo	ziya
12	ka-	ka-	-ka-	ka	aka	ako	kaja
14	u-	u-	-u-	wa	unu	uo	uja
15	ku-	ku-	(-ku-)	kwa	(kunu)	(uko)	(kuja)
16	ha-	ha-	-ha-	ha	aha	aho	haja
17	ku-	ku-	-ku-	kwa	kunu	uko	kuja
18	mu-	m-	-mu-	mwa	umu	umo	muja

**Prepositions and the locative suffix** The locative suffix *-i* is not very productive in Smbaa. It is only used with a small number of words of Bantu origin which have a locative meaning such as *ziwa* ‘lake’ and *mzi* ‘town’. Words such as *shule* ‘school’ or *mtwi* ‘head’ cannot take the locative suffix, as shown in (5c) and (5e). Swahili has a cognate locative suffix *-ni*, which, unlike in Smbaa, can attach to most inanimate proper nouns.

- (5) a. ziwa- i  
6lake- LOC  
'on/in the/a lake'
- b. nyumba- i  
9house- LOC  
'in the/a house'
- c. \* mtwi- i  
3head- LOC  
Int: 'on/in the/a head'
- d. \* shule- i  
9school- LOC  
Int: 'on/in the/a school'
- e. \* kape- i  
5church- LOC  
Int: 'on/in the/a church'

Examples of the Swahili pattern are shown in (6a) and (6b).

- (6) a. kichwa- ni  
7head- LOC  
'on/in the/a head'
- b. shule- ni  
9school- LOC  
'at (a/the) school'
- c. kanisa- ni  
9church- LOC  
'at (a/the) church'

[Swahili]

A noun such as *mtu* 'river' can take the locative suffix. This is shown in (7a). When the noun has this suffix, any agreeing element that modifies it must be inflected for a locative class, as shown in (7b). Agreement with class 3, the lexical class of *mtu*, is ungrammatical, as shown in (7c).

- (7) a. mtu- i  
3river- LOC  
'in/on a/the river'
- b. mja mtu- i  
18DEM 3river- LOC  
'there in/on the river'
- c. \* uja mtu- i  
3DEM 3river- LOC  
Int: 'in/on the river'

Apart from this means of expressing locatives, Sambiaa has locative constructions which involve a free form of the three locative classes in what looks like the *e*-type

relative marker and behaves syntactically like a free preposition, insofar as it precedes a noun, whereas the relative markers attach to a verb or copular element. There is a form for each of the three locative classes: *he* (class 16), *kwe* (class 17) and *mwe* (class 18). These forms have also been reported for the related language Zigua (Malin Petzel, p.c.). However, when *mto* is preceded by *mwe*, as shown in (8a), the demonstrative is class 3. *He*, *kwe* and *mwe* cannot take a noun with a locative suffix as their complement. This is shown for *mwe* in (8b).

- (8) a. *mwe uja mto*  
 18LOC 3DEM 3river  
 'in/on that river'  
 b. \**mwe mto- i*  
 18LOC 3river- LOC  
 'in/on the river'

This shows that the free locatives modify a whole noun phrase (DP) while the locative suffix modifies the noun itself. Like the prepositional elements *kwa* 'with, at', *ni* 'by' and *na* 'with, and' the locatives ending in /e/ must be followed by the noun they modify. Prepositions in Sambaa, never occur in phrase-final position.

Apart from modifying noun phrases, the *e*-locatives, most commonly *kwe*, can follow a motion verb and take a bare verb stem as their complement. This is illustrated in (9a). The infinitival form of the verb is ungrammatical in this case, as shown in (9b), but object marking is possible, as shown in (9c).<sup>2</sup>

- (9) a. N- aa- ita kwe kama mee.  
 SM1S- CONT.DJ- go 17LOC milk[verb] 6milk  
 'I am going (there) to milk.'  
 b. \* N- aa- ita kwe ku- kama mee.  
 SM1S- CONT.DJ- go 17LOC INF -milk 6milk  
 Int: 'I am going (there) to milk.'  
 c. a- i- taiye kuti i- iz- iye kwe wa-  
 SM1- PRF.DJ- know.PERF.CJ that SM9- come- PERF.CJ 17LOC OM2-  
 meza  
 swallow  
 '... she knows that it [the snake] has come to swallow them...'

**Verbal and nominal morphology** Apart from their noun classes, Bantu languages are also well-known for their agglutinative morphology. This is particularly visible in the verbal domain, where most Bantu languages have a considerable number of inflectional prefixes and derivational suffixes.

The inflectional affixes which appear on Sambaa verbs include subject markers and object markers, tense morphemes, negation markers, the reflexive marker, and several types of relative markers (RM). These are indicated in (10). Not all of these

<sup>2</sup>These might be analysable as relative clauses.

slots can be filled simultaneously. Certain slots such as the SM/prefixed RM slot, the final vowel position and the verb root can be filled only once, while, in Sambiaa, the tense position can be filled by several prefixes at once and the object marker position can potentially be filled by several object markers.

- (10) (Neg) - SM/prefixed RM- Tense - RM - OM/reflexive - verb root- derivational extensions- Final Vowel/Tense- suffixed RM

The verbal extensions which are productive in current Sambiaa include the applicative *-IL-*, the causative *-y-* or *-Ish-/-Iz-*, the two allomorphs of passive: *-ighw-* and *-w-*, the reciprocal *-an-*, the stative *-Ik-*, and the intensives *-Iz-* and *-Ish-*.<sup>3</sup> Roehl (1911:179-197) gives a number of examples for each extension and discusses the sound changes each suffix induces, as well as some unproductive extensions.

The *-w-* passive is usually used with derived stems, such as applied verbs, as in (11a), while *-ighw-* is used with non-derived stems, as in (11b), but a number of verbs can take either. For example the verb *-kunda* ‘like, love’ can be passivized either as *-kundwa* or as *-kundighwa* (Besha 1993:26).

- (11) a. N- za- dik- i- w- a nkande n’ tate.  
SM1S- PERF.DJ- cook- APPL- PASS- FV 9food by 1father  
‘Food was cooked for me (lit. I was cooked for food) by father.’
- b. Mampemba ya- za- dik- ighw- a n’ tate.  
6corn SM6- PERF.DJ- cook- PASS- FV by 1father  
‘The corn was cooked by father.’

Table 2.4: Verbal Extensions

Extension	Form	Example	Meaning
applicative	-IL-	kudikia	to cook for
causative	-y-	kudisha	to make cook
passive	-ighw-	kudikighwa	to be cooked
reciprocal	-an-	kuonana	to see each other
stative	-Ik-	kudikika	to be cookable
intensive	-Ish-	kudikisha	to cook intensively

The applicative can add a benefactive object to a transitive verb, such as *-dika* ‘cook’ in (12a), as shown in (12b). Other types of arguments which can be introduced by the applicative are (locative) goals, and to a very limited extent instrumentals. Reason applicatives are not grammatical in Sambiaa.

- (12) a. A- za- dik- a nkande.  
SM1- PERF.DJ- cook- FV 9food  
‘S/he cooked food.’

<sup>3</sup>Roehl claims that every verb can take either intensive and that each type has a slightly different meaning, with *-Ish-* indicating that an action is carried out intensively and *-Iz-* that an action is carried out thoroughly. He also states that the intensive with *-Ish-* is highly productive, unlike the intensive with *-Iz-* (Roehl 1911:190).

- b. A- za- ni- dik- i- a nkande.  
 SM1- PERF.DJ- OM1S- cook- APPL- FV 9food  
 ‘S/he cooked food for me.’

The nominal template for non-derived nouns is very simple in comparison, with only one prefix position, as shown in (13a). In some North East Coastal Bantu languages, including Sambia, a locative clitic can attach to the end of the noun. Deverbative and deadjectival nouns, as shown in (13b), are more complex since they can include any verbal derivation as well as a nominalizing suffix. Roehl (1911) discusses the derivations for nouns in some detail, and Besha (1989b) gives a short overview.

- (13) a. Non-derived nouns: noun class prefix - stem - locative clitic  
 b. Deverbative/Deadjectival nouns: noun class prefix - root (derivation) - nominalizing suffix

In the nominal domain, most but not all adjectives and numerals and the demonstratives agree with their head noun in noun class, this is illustrated in (14a). The noun need not be overt if it can be inferred from the context. Apart from the non-agreeing quantifier *kia*, borrowed from Swahili, shown in (14b) and the demonstratives, all modifiers, such as adjectives, numerals, quantifiers and possessive pronouns, always follow the noun.

- (14) a. Awa wana waili watana wa- za- bua.  
 2DEM 2child 2nice 2two SM2- PERF.DJ- arrive  
 ‘Those two nice children have arrived.’  
 b. Kia mshi, a- ta- isha ng’ombe zakwe.  
 every 3day SM1- PRES.DJ- feed 10cow 10POSS.3S  
 ‘Every day, she feeds her cows.’

Demonstratives can precede the noun or follow it. In Sambia, as in several other languages spoken in the same region, including Asu (Pare) and Mbugu, as well as Rangi, demonstratives frequently precede their head noun. In Sambia, according to Besha (1989b) this is related to the status of the nouns they modify as discourse-old or discourse-new entities, respectively. However, I found this claim not to hold. Both orders are grammatical, with subtle meaning differences which are affected by focus and deictic versus non-deictic uses. A deictic use of a distal demonstrative with a postnominal demonstrative is shown in (15a). The alternative order would also be acceptable here. In narratives, such as folk tales, it is particularly common to find the order demonstrative-noun used, as illustrated in (15b).

- (15) a. Ni- kunda matagi aya.  
 SM1S- want.PRES.CJ 6egg 6DEM  
 ‘I want those eggs.’  
 b. Basi uja mbwanga na jia kui wa- ka- kina na mwe uja  
 well 1DEM 1boy and 5DEM 5dog SM2- CONS- fall and 18LOC 3DEM  
 nto.  
 3river  
 ‘Well, the boy and the dog then fell into the river.’

As in many Bantu and other African languages, many concepts which are expressed by adjectives in Indo-European languages are expressed by verbs. This class of verbs includes words such as *kuchuta* ‘to be black’, *kuzwama* ‘to be heavy’, *kukandana* ‘to be dirty’ and *kudahaa* ‘to be completed’.

### 2.3.3 Subject and object marking

The subject marker agrees with the noun class, or, in the case of first or second person subjects, with the person and number of the subject. In unmarked word order, the subject appears preverbally. An example of a subject-verb sentence is shown in (16), where the subject marker is marked in bold face.

- (16) Ija nyoka **i-** tangwa Jungu.  
 9DEM 9snake SM9- call.PASS.PRES.CJ 1Jungu  
 ‘That snake is called Jungu.’

Irrespective of the presence or absence of a lexical subject, verbs in Sambia require a subject marker. One exception to this are imperatives, as shown in (17a). Infinitival constructions are less clear-cut. Infinitives in Sambia generally take a noun class prefix, namely class 15, as shown in (17b). However, when an infinitival verb is preceded by a particular type of preposition,<sup>4</sup> the noun class prefix is dropped, as shown in (17c).

- (17) a. Eka vuzo!  
 stop.IMP 9noise  
 ‘Stop making noise!’  
 b. N- aa- kunda ku- dika.  
 SM1S- CONT.DJ- like INF- cook  
 ‘I like to cook.’  
 c. Ni- ita kwe kama mee.  
 SM1S- go.PRES.CJ 17PREP milk(verb) 6milk  
 ‘I am going to milk.’ (lit. I am going to milk the milk)

Object markers are verbal prefixes which are prefixed immediately to the verb stem, and which, like subject markers, match the person and number or noun class features of a coreferential complement noun phrase, as (18) shows. The object marker *mu* is indicated in boldface and like the object noun *Stella* is class 1.

- (18) N- za- **mu-** ona Stella.  
 SM1S- PERF.DJ- OM1- see 1Stella  
 ‘I saw Stella.’

Sambia allows more than one object marker. In (19), the direct object and the indirect object agree with the verb. The morphosyntactic restrictions which govern the order and presence of these two prefixes are the main topic of this thesis, discussed in detail in chapters 3 and 5.

<sup>4</sup>Refer to section 2.3.2 for further discussion of these prepositions.

- (19) Haafu n- ta- **chi- m-** homea.  
 then SM1S- PRES.DJ- OM7- OM1- throw.APPL  
 ‘And then I will throw it at him.’

**I-initial verbs** A small number of Sambia verbs, including *kuinka* ‘to give’ and *kuikaa* ‘to live’, appear with the vowel /i/ in stem-initial position when there is no object marker, as in (20a), but without it when an object marker is present, as in (20b). Without object marking the form without the initial /i/ is ungrammatical, as shown in (20c). This vowel appears to be part of the lexical entry of the relevant verbs. It can appear with object marking as well, as in (20d), but this structure is not found often. A similar pattern is also found in the neighbouring languages (Mous 2003a).

- (20) a. A- ka- inka fishi nkaanga.  
 SM1S- CONS- give 5hyena 10peanuts  
 ‘He gave the hyena peanuts.’<sup>5</sup>
- b. A- ka- m- nka fishi nkaanga.  
 SM1S- CONS- OM1- give 5hyena 10peanuts  
 ‘He gave the hyena peanuts.’
- c. \* A- ka- nka fishi nkaanga.  
 SM1S- CONS- give 5hyena 10peanuts  
 Int: ‘He gave the hyena peanuts.’
- d. Awa wantu wangu wa- ink- e.  
 2DEM 2people poss2 OM2- give- IMP  
 ‘Those my people, give them.’

### 2.3.4 Word order

Sambia, like the majority of Bantu languages (Bearth 2003), is an SVO language.

- (21) Ng’wana a- za- eta matagi.  
 1child SM1- PERF.DJ- bring 6egg  
 ‘The child has brought eggs.’

Sambia has a strict constituent order for the complements of the verb. The indirect object precedes the direct object and any adjuncts, as shown in (22).

- (22) V IO DO ADJ

The acceptable word order is illustrated in (23a). Any other possible order of the postverbal constituents is ungrammatical, as examples (23b) to (23f) show .

- (23) a. N- za- inka ng’wana kitabu haja.  
 SM1S- PERF.DJ- give 1child 7book 16DEM  
 ‘I gave the child a book there.’

<sup>5</sup>In fairy tales, where animals have human-like behaviour, class 1/2 and the class of the word for the animal are used interchangeably for subject and object marking.

- b. \* N-    za-       inka ng'wana haja    kitabu.  
       SM1S- PERF.DJ- give 1child  16DEM 7book  
       Int: 'I gave the child a book there.'
- c. \* N-    za-       inka kitabu ng'wana haja.  
       SM1S- PERF.DJ- give 7book 1child  16DEM  
       Int: 'I gave the child a book there.'
- d. \* N-    za-       inka kitabu haja    ng'wana .  
       SM1S- PERF.DJ- give 7book 16DEM 1child  
       Int: 'I gave the child a book there.'
- e. \* N-    za-       inka haja    ng'wana kitabu.  
       SM1S- PERF.DJ- give 16DEM 1child  7book  
       Int: 'I gave the child a book there.'
- f. \* N-    za-       inka haja    kitabu ng'wana.  
       SM1S- PERF.DJ- give 16DEM 7book 1child  
       Int: 'I gave the child a book there.'

### 2.3.5 Tense-aspect marking and syntax

Sambiaa has a rich system of tense aspect inflections. There are several pasts, presents and future tenses, apart from aspectual or backgrounding markers. Sometimes the tenses are distinguishable based on their conjoint/disjoint properties (discussed below), while in other cases the distinction is by relative distance from the speech time or by aspectual properties such as being progressive/completive. Most tense markers are prefixes which follow the subject marker but there are also suffixes (the conjoint perfective), tonally marked tenses (the conjoint present), and markers which are attached before the subject marker (the future and progressive *ne-*). A number of tense prefixes have two variants: a form which ends in the vowel /a/ and a form which ends in the vowel /e/. These are generally different in terms of temporal information, for example *-tà-* is present and *-té-* is past while *-zà-* is perfective and *-zé-* is future<sup>6</sup>. The most common tenses, and those which appear in this thesis are listed in table 2.5. Besha (1989b) lists the future forms *ne* and *nee*, which she treats as a near future (*ne*) a far future (*nee*). The speakers I worked with did not seem to use *nee* as a future tense<sup>7</sup> but *ne* and *nge* with no apparent difference in the reference time.

- (24) A-   te-       vyaa       wanae       wengi.  
       SM1- NPST.DJ- give.birth 2child.POSS.3S 2many  
       'He fathered his many children.' [taken from a traditional Sambiaa story]

The meanings listed for the tense markers in table 2.5 follow Besha (1989b) to a large extent. Roehl (1911), on the other hand, classifies a number of Sambiaa tenses differently. The problem is that in combination with other markers the “basic” meaning appears to shift. Although both Besha and Roehl give many examples of tense and

<sup>6</sup>I don't discuss this marker here. For more examples of the *-a/-e* alternation see Roehl 1911:145-151.

<sup>7</sup>In my data, *nee* appears as a progressive copula that seems to be more free than the *ne-* prefix.

Table 2.5: Sambia Tense-Aspect Markers

Morpheme	Meaning	Gloss
present		
-tà-	simple present	PRES.DJ
-L	present conjoint	PRES.CJ
-àà-	(present) continuous	CONT.DJ
past		
-íyé	perfective (past) conjoint	PERF.CJ
-zà-	perfective (past) disjoint	PERF.CJ
-ì-	perfect	PRF.DJ
-té-	near past	NPST
-à-	remote past conjoint	REM.CJ
-á(à)-	remote past disjoint	REM.DJ
future		
nè- -è	future	FUT
ngè- -è	future	FUT
other		
-hè-	situative	SIT
-kí-	situative, progressive <sup>8</sup>	SIT
nè(è)-	progressive	PROG
-kà-	consecutive tense	CONS
-nà-	used in combinations to express remoteness	MD
-è	subjunctive	SUBJ

aspect in Sambia, a more careful analysis is still needed in my view. The claims in Besha are sometimes contradictory, and many of the labels and combinations in Roehl strike me as problematic and data from both sources was frequently rejected by my informants. The labels used here should therefore be taken as an approximation to the meaning of each morpheme rather than a definite analysis. Below I discuss the use of the *-ta-* marker in discourse to illustrate the complexities involved.

Some combinations of tense-aspect markers are less problematic, for example in (25), *-za-* marks a future perfective in combination with *-ki-* and a matrix clause verb inflected for future.

- (25) U- ki- za- shaghua iyo namba ndi- yo u- tumi- e  
 SM2S- SIT- PERF.DJ- choose 9DEM 9number COP- RM9 SM2S- use SUBJ  
 ne- u- ni- ghambi- e.  
 FUT- SM2S- OM1S- tell- SUBJ  
 ‘Once you have chosen the number that you will use you will tell me.’

However, consider (26).

- (26) a. A- ki- ung'wa n' saa ng'wenye a- ta- na- nywa  
SM1- SIT- bite.PASS by 9hunger 1self SM1- PRES.DJ- MD- drink  
chai.  
9tea  
'If he gets hungry himself, he would drink tea.'
- b. U- ta- na- gosha wedi!  
SM2S- PRES.DJ- MD- sleep well  
'Sleep well (later)!'
- c. U- te- na- chi- m- nka?  
SM2S- NPST.DJ- MD- OM7- OM1- give  
'Have you given it to her?'

By itself, *-ta-* behaves like a simple present tense, but in combination with *-na-*, the verb receives a today future reading. For example (26b), is commonly used when saying goodbye to someone in the afternoon, several hours before bedtime. In the evening, the imperative form without tense will be used. The prefix *-na-* also appears with the perfect *-te-*, as in (26c). Roehl (1911:113) analyses *-ta-* as encoding (speaker) intention (or a decision to do something) rather than present tense. He claims it is mostly used for future, but occasionally also for present or past. I analyse *-ta-* as a simple present because this seems to better reflect its use in stories or instructions to express a general present tense. For example in (27a), the beginning of a narrative explaining how to cultivate maize is shown. The entire narrative uses the *-ta-* marker, except where things happen at a later stage, as in (27b), in which case the subjunctive is used. In this narrative, a future or a present, or in fact the intentional reading suggested in Roehl would be plausible.

- (27) a. U- ki- kunda ku- ima mampemba u- ta- tayarisha  
SM2S- SIT- want INF- cultivate 6maize SM2S- PRES.DJ- prepare  
ubua wako mkuu.  
14farm 14your 14main  
'If you want to cultivate maize you prepare you main farm.'
- b. U- ta- ya- ika vyedi mja mwe ubua ili ya-  
SM2S- PRES.DJ- OM6- put 8well 18DEM 18LOC 14farm so.that SM6-  
kagha- e ya- tend- e mbolea.  
dry- SUBJ SM6- become- SUBJ 9fertilizer  
'You place them [the leaves] properly, there in the field, so that they dry  
and become fertilizer.'

In stories, *-ta-* is used for events which take place at the event time. This is illustrated in (28), the earlier event is narrated with the *-ka-* tense, followed by the situative *-he-* and finally *-ta-* to express the present tense. This example is from narrating the *Frog Story*, where the *-ta-* is used to describe a state in the picture that the narrator is looking at. In this case neither intention nor future seem plausible, whereas the present tense reading is plausible in both kinds of context.

- (28) Ji- ka- nyiika. [...] ng'wana a- he- inuka kwe weeya jula  
 SM5- CONS- run.away 1child SM1- SIT- get.up 17LOC look.at 5frog  
 mwe giyasi he- ji- mo. Uja ng'wana a- ta- maka.  
 18LOC 9glass NEG- SM5- RM5 1DEM 1child SM1- PRES.DJ- be.surprised  
 'It [the frog] has run away. [In the morning], when the child gets up to look at  
 the frog in the class it [the frog] is not there. The child is surprised.'

In Sambia, multiple tense-aspect markers can be stacked in a single verb (for detailed discussion of this see Besha 1985, 1989b; Nurse 1979; Roehl 1911). In (29), a verb with three tense markers is shown.

- (29) Ni- ta- za- na- mu- itanga.  
 SM1S- PRES.DJ- PERF.DJ- MD- OM1- call  
 'I might possibly call her.' [Besha 1993:18]

In my corpus of Sambia narratives, combinations of two prefixed tense markers were rare, while combinations of three or more tense markers, do not appear in my data at all. The sentence in (29) was judged as ungrammatical by some of my informants, while combinations of any two of the morphemes involved were judged as acceptable. In such combinations, the order of the morphemes is fixed, and combinations are not free in terms of which markers may combine with which. As in the example from Besha (1993), in my data, verbs with two prefixed tense markers used *-ta-* and *-na-*. Combinations of the perfect prefix *-i-* with the suffix *-iye* are also common. This is the only way the *-i-* perfect can be used.

In Sambia, tense marking interacts with negation and relativization, both of which are marked with verbal morphology, and *wh*-questions, as well as information structure more generally.

### Conjoint and disjoint verbs

In a number of Bantu languages, verbs marked with certain tense marking morphemes are analysed as being either conjoint or disjoint<sup>9</sup>. This large and diverse group of Bantu languages includes the Nguni languages (Buell 2005; van der Spuy 1993), the Sotho-Tswana languages (Cole 1955; Creissels 1996; Doke and Mofokeng 1974), Makhuwa (van der Wal 2006) and Rundi (Meeussen 1959). Although the conjoint or disjoint property of a verb is encoded by morphemes which also encode temporal or aspectual information, the distinction is not related to tense, aspect or mood but to syntactic constituency and information structure. There are two basic properties which determine the distribution of conjoint and disjoint forms: firstly a conjoint verb cannot be in the phrase-final position; and secondly a disjoint verb cannot precede certain focal items, such as *wh*-words. The finer properties of the conjoint/disjoint distinction are not uniform across Bantu (Buell and Riedel 2008). In most Bantu languages which have the conjoint/disjoint distinction, only some tenses show the distinction. Typically, these

<sup>9</sup>Several other labels are used for this type of pattern. For example, in the literature on the Southern Bantu languages, the conjoint form and the disjoint form are traditionally referred to as the short form and long form respectively.

include the perfective and present tense. Languages differ as to whether certain tenses can be used in both conjoint and disjoint environments, and are thus neutral. Across Bantu, the conjoint/disjoint alternation interacts with object marking, phrasing and the syntax of questions. These issues are discussed in chapters 3 and 6.

In Sambia, of the multitude of tense markers only a small number are conjoint. In Besha (1989b), the conjoint forms are referred to as “dependent” tenses. There is no conjoint/disjoint distinction in the future, subjunctive and imperative, nor in the negative. However, amongst the non-future affirmative tense markers there are no neutral forms. The conjoint tenses in Sambia are the present (without a prefix and with a low tone on the final vowel), the perfective *-iye*, and the remote past *-a-*. All other tenses are disjoint. This means that for the present and the perfective (basic past) conjoint forms there are several potentially matching disjoint tenses.

In (30a), a conjoint verb appears in the verb phrase final position; this is ungrammatical. In (30b), the conjoint verb is followed by an object; this is grammatical. Unlike a conjoint verb, a disjoint form can appear in the final position, as shown in (30c).

- (30) a. \*Ni- it- iye.  
           SM1S- go- PERF.CJ  
           Int: ‘I went.’ (conjoint)
- b. Ni- it- iye kaya.  
           SM1S- go- PERF.CJ 16home  
           ‘I went home.’ (conjoint)
- c. N- za- ita.  
           SM1S- PERF.DJ- go  
           ‘I went.’ (disjoint)

The labels “conjoint” and “disjoint” in the gloss of particular morphemes do not determine by themselves whether a verb is conjoint or disjoint. Whether a verb is conjoint or disjoint (in a non-future tense), is determined by the combination of conjoint and disjoint morphemes present. A verb with only a conjoint morpheme is conjoint. Any verb that includes a disjoint morpheme is disjoint, irrespective of whether there is a conjoint morpheme present as well or not. One example of this is the combination of the conjoint *-ile* perfective suffix with the disjoint *-i-* perfect prefix. The pattern is illustrated in (31). Where the conjoint perfective appears without the disjoint perfect, as in (31a), the inflected verb is ungrammatical in sentence-final position. Where both morphemes appear it is grammatical in this position, as shown in (31b).

- (31) a. \*Ng’wana a- lal- iye.  
           1child SM1- sleep- PERF.CJ  
           Int: ‘The child is sleeping (lit. has fallen asleep).’ (conjoint)
- b. Ng’wana a- i- lal- iye.  
           1child SM1- PERF.DJ- sleep- PERF.CJ  
           ‘The child is sleeping (lit. has fallen asleep).’ (disjoint)

In table 2.6 a number of common tense markers in Sambia and their behaviour with regard to the conjoint/disjoint distinction is shown.

Table 2.6: Conjoint and Disjoint Forms in Sambia

Morpheme	Status	Meaning
present		
-tà-	disjoint	present
-L	conjoint	present
-àà-	disjoint	continuous
past		
-íyé	conjoint	perfective (past)
-zà-	disjoint	perfective (past)
-ì-	disjoint	perfect
-té-	disjoint	near past
remote past		
-à-	conjoint	remote past
-á(à)-	disjoint	remote past

The tense markers *-za/-iye* and *-i-* are illustrated in (30) and (31), respectively. An example of *-te-*, is shown in (32).

- (32) Á- té- kwéá ná úkó táái ...  
 SM1- NPST.DJ- climb with 17DEM 5roof  
 ‘She has climbed onto the roof...’

Examples of the present tense forms are shown in (33). *Kuja* ‘to eat’ has a high tone on the final vowel. However, in the present conjoint tense this is realised as low, as shown in (33a). In the disjoint present, more aspectual distinctions are made, there is a continuous marker, as in (33b), and a simple present marker, as in (33c).

- (33) a. Ng’òmbè zí- jà màni. (conjoint)  
 10cow SM10- eat.PRES.CJ 6grass  
 ‘Cows eat/are eating grass.’  
 b. Ng’òmbè z- àà- já. (disjoint)  
 10cow SM10- CONT.DJ- eat  
 ‘The cows graze/are grazing.’  
 c. Ng’òmbè zí- tà- já. (disjoint)  
 10cow SM10- PRES.DJ- eat  
 ‘The cows graze.’

The remote past conjoint and disjoint forms are shown in (34).

- (34) a. Àhò kàè n- à- sómá hàjà. (conjoint)  
 16DEM far SM1S- REM.CJ- read 16DEM  
 ‘Back then I studied there.’  
 b. Àhò kàè n- àà- sómá. (disjoint)  
 16DEM far SM1S- REM.DJ- read  
 ‘Back then I studied.’

In the future the two forms NE- and NGE- can both be used in both conjoint and disjoint contexts. For example in the clause-final position, as in (35a) and (35b), and before a *wh*-element, as in (35c) and (35d). Besha (1989b:236) also notes that there is no conjoint/disjoint distinction in the future for the two tense markers she discusses.

- (35) a. Ne- n- shezigh- e.  
 FUT- SM1S- play- SUBJ  
 'I will play'
- b. Nge- u- kund- e?  
 FUT- SM2S- want- SUBJ  
 'Will you want?'
- c. Ne- wa- imb- e mbwai?  
 FUT- SM2- sing- SUBJ what  
 'What will they sing?'
- d. Nge- u- kund- e- i?  
 FUT- SM2S- want- SUBJ- what  
 'What will you want?'

Apart from being followed by another constituent, the focal properties also matter. In Sambia, the disjoint form is judged as better when introducing a completely new object. The paradigm for this is illustrated in (36). The context for this example is that the speaker is a customer at a shop. If no *wh*-question has preceded the utterance which expresses what the speaker wants to buy, the disjoint form is used as shown in (36a). In this context, the conjoint form, shown in (36b), is judged as pragmatically odd. However, in the answer to a *wh*-question, the inverse pattern holds. As shown in (36c), the conjoint form is acceptable in the answer here, while the disjoint form is judged as odd. The disjoint form is shown in (36d). The continuous disjoint tense is frequently used where the conjoint present would be ungrammatical. They are somewhat equivalent in terms of tense-aspect semantics. The *-ta-* can also be used to replace the conjoint present, but does not imply that the action is ongoing. In terms of the distribution of the conjoint and disjoint form in this context, the opposite pattern is found in other Bantu languages with a conjoint/disjoint distinction, such as Makhuwa and Zulu (Jenneke van der Wal and Leston Buell, p.c.).

- (36) a. N- aa- kunda mavuta ya taa ya shiinigi mia  
 SM1S- CONT.DJ- want 6oil 6ASSOC 9lamp 6ASSOC 9shiling 9hundred  
 ng'wenga.  
 one  
 'I want lamp oil for 100 shilings.' (disjoint)
- b. #Ni- kunda mavuta ya taa ya shiinigi mia  
 SM1S- want.PRES.CJ 6oil 6ASSOC 9lamp 6ASSOC 9shiling 9hundred  
 ng'wenga.  
 one  
 'I want lamp oil for 100 shilings.' (conjoint)

- c. U- kunda- i? Ni- kunda mavuta.  
 SM1S- want.PRES.CJ- what SM1S- want.PRES.CJ 6oil  
 ‘What do you want? I want (lamp) oil.’ (conjoint verb in answer)
- d. U- kunda- i? # N- aa- kunda mavuta.  
 SM1S- want.PRES.CJ- what SM1S- CONT.DJ- want 6oil  
 ‘What do you want? I want (lamp) oil.’ (disjoint verb in answer)

In Sambia, the disjoint tense marker *-zâ-* and *-tâ-* are strongly preferred for out-of-the-blue statements. This is also noted in Besha (1989b). Constructed examples without context are generally rendered in this tense. This can also be seen in the very high prevalence of this tense in the examples used to illustrate the behaviour of object markers in Sambia in this thesis.

The syntax of the conjoint/disjoint alternation and whether it is connected to object marking in Sambia, is discussed further in chapters 3 and 6.

### 2.3.6 Relative clauses

Sambia has a very complex morphological marking system for relative clause formation. Apart from an analytic strategy using *ndi-*, there are two different sets of relative markers which can be prefixed or suffixed to the verb. In addition to those, at least some speakers also use the agreeing free *amba-* relative marker that is used in Swahili.<sup>10</sup> The different morphological relativization strategies appear primarily with particular tenses or aspects. Relative verbs, like negative verbs, cannot generally be said to be either conjoint or disjoint. This is reflected in the gloss by not labelling the tense morphemes as conjoint or disjoint. However, comparing the type of tense markers which allow a relative marker on the verb to the data in table 2.6, it is clear that the tenses which allow affixation of relative markers to the verb are those which are morphologically conjoint.

**Relative marking morphology** There are two types of relative markers for each noun class, as shown in table 2.7. Both contain a vocalic base fused with a nominal class marking consonant or a consonant and a glide, one has the vowel /e/ in all forms (the *e*-type), and one has the vowel /o/ for all classes (the *o*-type), with the exception of class 1 where both forms have the vowel /e/. With the other noun classes, for example for class 7, the forms are *che-* and *cho-*.

The *e*-type is always prefixed, either without a subject marker (for subject relatives), as shown in (37a), or following a subject marker (for object relatives), while the other type of relative marker is either suffixed, as shown in (37b), or appears as a prefix which follows the subject marker, as shown in (37c).

- (37) a. kitabu che- tama  
 7book RM7- please.PRES  
 ‘the book that is nice’

<sup>10</sup>Swahili, like many other Bantu languages, has relative markers which are cognate with the *o*-type in Sambia. As in Sambia, these can be prefixed or suffixed and appear with particular tenses. The syntax of these is compared with the syntax of Sambia relative clauses in chapter 6.

Table 2.7: Smbaa Relative Markers

Noun class	NC PREF	<i>o</i> -type	<i>e</i> -type
1	m-	-ye(-)	(-)mwe-
2	wa-	-wo(-)	(-)we-
3	m-	-wo(-)	(-)we-
4	mi-	-yo(-)	(-)ye-
5	∅/ i-/ zi-	-jo(-)	(-)je-
6	ma-	-yo(-)	(-)ye-
7	ki-	-cho(-)	(-)che-
8	vi-	-vyo(-)	(-)vye-
9	N-	-yo(-)	(-)ye-
10	N-	-zo(-)	(-)ze-
12	ka-	-ko(-)	(-)ke-
14	u-	-o(-)	(-)we-
15	ku-	-ko(-)	(-)kwe-
16	ha-	-ho(-)	(-)he-
17	ku-	-ko(-)	(-)kwe-
18	mu-	-mo(-)	(-)mwe-

- b. kitabu a- kund- iye- cho  
 7book SM1- like- PERF- RM7  
 ‘the book that she liked’
- c. kitabu a- cho- kunda  
 7book SM1- RM7- like.PRES  
 ‘the book that she likes’

**Relative clauses with the *e*-type relative marker** When the *e*-type of the relative marker is used for relativizing subjects, there is no subject marking morphology, and, typically, tense prefixes are ungrammatical. An example of this strategy is shown in (38a). This kind of relative clause generally receives a general present tense reading. However, the perfective suffix *-iye*<sup>11</sup> can also appear with this form, as shown in (38b).

- (38) a. Waja waghoshi we- iza ni wagheni wetu.  
 2DEM 2man RM2- come.PRES COP 2guest 2our  
 ‘The men who are coming are our visitors.’ [Besha 1993:33]
- b. Mwaimu mkuu mwe- to- ighw- e m’ mwaimu ne- a- ighaw-  
 1teacher 1big RM1- hit- PASS- PERF by 1teacher fut- SM1- send.PASS  
 e hospitai.  
 -SUBJ 9hospital  
 ‘The headmaster who was hit by the teacher will be taken to hospital.’

<sup>11</sup>With verb stems that include derivation morphemes, such as passive verbs, the form of this suffix is *-e*.

In older Sambia, this form apparently could combine with tense prefixes. Roehl gives several examples of such constructions. Two of these are shown in (39a)<sup>12</sup> and (39b). My informants generally rejected these, but one informant found (39b) acceptable. This is surprising, seeing as in all other cases the tenses which allow affixation of a relative marker to the verb are those which are analysable as conjoint in non-relative clauses.

- (39) a. muntu mwe- za- kula  
 1person RM1- TNS- grow  
 ‘ein Mensch, welcher mal gross werden wird’  
 ‘a person, who will grow big one day’ [Roehl 1911:157]
- b. muntu mwe- ta- kula ivyoho  
 1person RM1- PRES.DJ- grow like.this  
 ‘ein Mensch, welcher doch so gross ist’  
 ‘a person who will grow big like this’ [Roehl 1911:157]

Object marking is somewhat more restricted with this type of relative clause. However, it does appear in natural speech, as in (40). This phrase was used in a private email to the author.

- (40) ... mamangu mwe- ni- vyaa imi ... ‘... my mother, who  
 1mother.POSS.1S RM1- OM1S- give.birth.to me  
 has given birth to me ...’

In elicitation, sometimes object marking was rejected outright with this type of relative clause, whereas other speakers allowed one object marker but not two. This is illustrated in (41).

- (41) a. ng’wana mwe- chi- ghula kiti  
 1child RM1- OM7- buy 7chair  
 ‘the child who bought the/a chair’
- b. ng’wana mwe- ni- ghuliya kiti  
 1child RM1- OM7- OM1- buy.APPL 7chair  
 ‘the child who bought me the/a chair’
- c. \* ng’wana mwe- chi- ni- ghuliya kiti  
 1child RM1- OM7- OM1- buy.APPL 7chair  
 Int: ‘the child who bought me the/a chair’

This relativization strategy is also possible for object and adjunct relatives, where the relative marker follows the subject marker. This is shown for a direct object in (42a), an applied locative in (42b), the agent of a passive in (42c) and for an adjunct expressing the manner in (42d).

<sup>12</sup>Note that -zâ- which is the perfective disjoint form in current Sambia is used here as a kind of future marker. Possibly this reflects an earlier stage in the grammaticalization of the form. It is not grammatical in current Sambia.

- (42) a. Kitabu n- vye- kunda kusoma m' vitana.  
7book SM1S- RM7- like to.read COP 8good  
'The books which I like to read are good.'
- b. mkoa wa Manyara nee n- kwe- goshoea  
3region 3ASSOC Manyara COP.PROG SM1S- RM17- work.APPL.PRES  
ndima  
9work  
'Manyara region, where I am working'
- c. n- che- tamiwa  
SM1S- RM8- be.pleased.PASS  
'what I like' (lit. what I am please by)
- d. jinsi a- vye- imba  
9manner SM1- RM8- sing  
'how s/he sings'

These are far less common than subject relatives, with this type of relative morphology. This might be because the general present reading is more common with subjects than with objects. In Roehl (1911), it is claimed that object and adjunct relatives are not grammatical with this relative marker. However, Besha (1989b) gives examples of such constructions. One such example is shown in (43).

- (43) Ng'ombe ti- ze- ghotosha ni za tate.  
10cow SM1P- RM10- bring.back COP 10ASSOC 1father  
'The cows that we are bringing back belong to father.' [Besha 1989b:92]

**The prefixed *o*-type relative marker** The prefixed *o*-type relative marker is always attached after the subject marker. An example of it is shown in (44a). This form can appear with subject relatives and object relatives. As (44b) shows, object marking is possible with this construction.

- (44) a. Mvyee a- ye- m- nka lifti a- aa- tamiwa.  
1woman SM1- RM1- OM1- give.PRES 9lift SM1- CONT.DJ- be.pleased  
'The woman whom he gives a ride is happy.'

**The suffixed relative marker** The suffixed relative marker appears with the perfective suffix, as well as the remote past and the general present. An example with the *-iye* suffix is shown in (45a), while the remote tense is shown in (45b). With this relativization strategy, subject (45a) and object relatives (45b) and (45c), as well as object marking, shown in (45b), are acceptable.

- (45) a. Kia ji- it- iye- jo he- ji- uye na iwe ne- u-  
every SM5- go- PERF- RM5 NEG- SM5- return.PERF and you FUT- SM2S-  
dah- e?  
be.able- SUBJ  
'Each [one] that went did not return, and you will be able to?'

- b. Mvyee a- m- nk- iye- ye lifti a- aa- tamiwa.  
 1woman SM1- OM1- give- PERF- RM1 9lift SM1- CONT.DJ- be.pleased  
 ‘The woman whom he gave a ride was happy.’
- c. Kitabu a- a- soma- cho zuzi ni kitana.  
 7book SM1- REM- read- RM7 day.before.yesterday COP 7nice  
 ‘The book he read the day before yesterday is nice.’

The suffixed relative marker can also be added to *na* ‘and, with’ and to auxiliary constructions using *na*. This is illustrated in (46). In (46a) the use with the ‘have’-construction is shown. (46b) shows an instrumental construction. Note that the relative marker appears twice here, first on the verb and then on the preposition.

- (46) a. Hekuna kintu chedi chi- shi- na- cho hasaa.  
 there.is.not 7thing 7good SM7- NEG- be.with- RM7 9disadvantage  
 ‘There is no good thing which doesn’t also have disadvantages.’
- b. siyo jia kuu u- hand- iye- jo na- jo  
 NEG.COP 5DEM 5big SM2S- plant- PERF- RM5 with- RM5  
 ‘not the big one [hoe] that you cultivate with’

Unlike with the *e*-type, two object markers are grammatical with a ditransitive verb with this kind of relative construction, as shown in (47).

- (47) Ng’wana a- chi- ni- ghuliye- ye kiti ni mtana.  
 1child SM1- OM7- OM1S- buy.APPL.PERF- RM1 7chair COP 1nice  
 ‘The child who bought me the chair is nice.’

**Analytic relative clause constructions** Sambia has two types of analytic relative clauses, that is relative clauses where the relative marking morphology does not appear on the verb but on an independent word. There is a copular strategy which uses the copula *ndi-* with a relative suffix of the *o*-type. This form, like verbs in the future tense, occurs with verbs in the subjunctive mood (which are marked by the final vowel *-e*), as in (48a) and (48b), or with verbs which are marked with the prefix *-ki-*, as in (48c), which have a continuous or conditional reading. Again, subjects and objects are possible.

- (48) a. I- ki- buiza ghoto, ji- ta- mezighwa, chochoshe chia  
 SM9- SIT- meet 5sheep SM5- PRES.DJ- swallow.PASS 7anything 7DEM  
 ndi- cho chi- buizw- e chi- ta- mezighwa.  
 COP- RM7 SM7- meet.PASS- SUBJ SM7- PRES.DJ- swallow.PASS  
 ‘If it [the python] comes across a sheep it is swallowed, anything [at all]  
 which it meets is swallowed.’
- b. Mvyee ndi- ye a- m- nk- e lifti ne- a- tamiwe.  
 1woman COP- RM1 SM1- OM1- give- SUBJ 9lift FUT- SM1- be.pleased  
 ‘The woman who he will give a ride will be happy.’

- c. Kitabu ndi- cho a- ki- soma n- he- bua nee chi  
 7book COP- RM7 SM1- SIT- read SM1S- SIT- arrive COP.PROG COP7  
 kibada  
 7bad  
 ‘The book which he was reading when I got there is bad.’

Lastly, relative clauses can be formed using the *amba-* complementizer in Sambia. These forms might be a borrowing from Swahili. This is because when asked whether these forms are acceptable in Sambia, my language consultants would decline and say that they only exist in Swahili. However, they all produced them when no other option was available. An example, from a recorded narrative, is shown in (49). This strategy is frequently used with non-argument relative clauses. As in Swahili, this form is unrestricted with respect to tense.

- (49) Haafu a- i- z -iye na mvyee amba- ye ni mtana  
 then SM1- PERF.DJ- come- PERF.CJ and 1woman *amba-* -RM1 COP 1nice  
 sana.  
 very  
 ‘Then he came with a woman who was very nice.’ (*aiziye* is disjoint)

## CHAPTER 3

---

### Object marking in Bantu: Agreement or pronominal clitics

---

#### 3.1 The agreement/pronoun distinction

There are clear morphosyntactic differences between subject marking and object marking in Bantu. While in the vast majority of the Bantu languages subject marking is obligatory, whether or not the subject is lexically expressed, object marking is much more restricted in its distribution and much less uniform across Bantu. Although, as I argue here, some Bantu languages have obligatory object marking, object marking is never obligatory for all objects in any Bantu language. Moreover, all Bantu languages which have object marking allow object markers to appear without a lexical object, filling what looks like, at least superficially, a pronominal role (see chapter 1 for an overview of the distribution of object marking across Bantu). In many Bantu languages, object marking is required when an object NP is dislocated, for example in topicalization (but see Matengo (Yoneda 2008) for an exception to this), and in some languages, most prominently Chichewa (Bresnan and Mchombo 1987), object marking is said to license free word order. These properties have fuelled the ongoing debate on the status of object markers in Bantu.

Baker (1996) characterises polysynthetic languages as languages where the syntactic arguments are expressed by verbal affixes and the co-referential lexical noun phrases have adjunct status.<sup>1</sup> Bantu languages are not polysynthetic in the sense of Baker (1996). But since Bresnan and Mchombo (1987), who follow Nichols (1986) on incorporation, an essentially parallel analysis that is referred to as pronoun incorporation has been adopted for many southern, central and eastern Bantu languages (see Byarushengo et al. 1976; Demuth and Johnson 1990; Letsholo 2002; Mchombo

---

<sup>1</sup>The definition and diagnostics for polysynthetic languages include a number of other properties not relevant here (see Baker 1996).

2004; Rubanza 1988; van der Spuy 1993; Zerbian 2006). In these analyses, the lexical object is analysed as an adjunct. In more recent work, Mchombo (2004, 2001) has taken this analysis further towards a polysynthesis-type analysis by claiming that Chichewa has discontinuous constituents.

In most of the Bantu literature addressing the status of the object marker, the conclusion is that some Bantu languages, most famously Swahili (Bresnan and Mchombo 1987), but also languages like Sambia, (Baker 2008) have object agreement, while others like Haya (Baker 2008; Bearth 2003; Byarushengo et al. 1976; Duranti and Byarushengo 1977), Chichewa (Bresnan and Mchombo 1987; Mchombo 2004), Northern Sotho (Zerbian 2006), Northern Sotho (Demuth and Johnson 1990) and Zulu (van der Spuy 1993) do not.

There are two main questions related to the agreement/pronoun distinction in Bantu: What is the status of the object marker? And what is the status of the lexical object when a co-referential object marker is present? If the object marker is the argument of the verb, then any co-referential object must be an adjunct. Since in many Bantu languages object-marked objects tend to receive a topical or definite interpretation (see Ashton 1944; Doke 1931; Nash 1992), an “object” doubled by an object marker is analysed as a topic. The “object” is also frequently analysed as a right-dislocated element (Byarushengo et al. 1976; Tenenbaum 1977; van der Spuy 1993). If, on the other hand, the object marker is an agreement marker, the object is the argument of the verb, whether it is overtly expressed or not. The implications of each type of analysis are discussed in chapter 4. The focus in this chapter is on the morphosyntactic properties of object-marked objects across a number of Bantu languages.

Two key concepts in this discussion are doubling and obligatory object marking. I define them as follows:

- (1) a. Doubling: The co-occurrence of an object marker with a co-referential lexical object.
- b. Obligatory object marking: A language has obligatory object marking if there is any group of lexical object noun phrases with a particular set of features (such as [+human] objects) which must co-occur with object marking, in order for a sentence to be judged as grammatical.

To illustrate these definitions, consider the sentences in (2). In (2a) *zi* doubles the noun phrase *picha hizo*. Without the object marker, the sentence in (2b) would be judged ungrammatical by any speaker of Standard Tanzanian or Kenyan Swahili or any of the coastal dialects.

- (2) a. N- li- zi- ona picha hizo. (doubling)  
SM1S- PAST- OM10- see 10picture 10DEM  
'I saw those pictures.'
- b. Ni- li- \*(mw)- ona Juma. (obligatory object marking)  
SM1S- PAST- OM1- see 1Juma  
'I saw Juma.'

[Swahili]

With regard to doubling, the contentious issue is whether an “object” that is doubled by an object marker is local and argument-like in any given language. In the Bantu literature, the predominant view is that pronominal object markers cannot double a local object, but agreement-type object markers can. Most Bantu languages allow doubling to take place with what looks like SVO order,<sup>2</sup> but arguably only some Bantu languages allow local doubling. In the literature, the main evidence which is presented for dislocation (against local doubling) is prosodic (Bresnan and Mchombo 1987; Byarushengo et al. 1976) or based on the interaction between doubling and the conjoint/disjoint alternation (van der Spuy 1993).<sup>3</sup> Henderson (2006b) proposes co-occurrence as a decisive criterion with the ability of an object-marked object to precede a temporal adverbial as evidence. According to this analysis, only objects which must follow a temporal adverbial are dislocated. There are alternative accounts for Zulu, where the conjoint/disjoint alternations are argued to delimit the verb phrase in a very local sense, and an agreement relation is argued to hold between the object and the object marker (Buell 2005; Henderson 2006b). In those accounts, it is argued that certain types of objects cannot remain inside the VP and move for that reason rather than because of not being able to co-occur with a pronoun.<sup>4</sup>

In this chapter, I discuss the literature on the nature of object marking in Bantu, review the suggested diagnostics and compare the properties of object markers in Samba and Haya with each other and with a number of other Bantu languages. For many of the morphosyntactic properties discussed here, it looks as if there are two (or more) types of Bantu languages. In the discussion here, these are represented by Samba and Swahili as one type, and Haya as the second type. However, the languages discussed do not form consistent and predictable groups. This means that the tests proposed in the literature to distinguish pronominal systems from agreement systems show mixed results. I conclude that there is no good evidence for dividing Bantu languages into two groups based on the syntactic status of the object marker as a pronoun or agreement marker. There are two possible hypotheses about the analysis of object marking based on this conclusion: either all Bantu languages have object agreement or all Bantu languages have pronominal object clitics. I take the view that Bantu languages have object agreement. The implementation of that proposal and the problems which arise from this are discussed in chapter 4.

In section 3.2 of this chapter, I discuss obligatory object marking in a number of Bantu languages. In section 3.3, I discuss object marking and dislocation, focussing on Bresnan and Mchombo (1987). In section 3.3.3, I argue against the analysis proposed in Bresnan and Mchombo (1987) based on data from Haya. In section 3.4, I discuss morphosyntactic variation with regard to object marking in Bantu and review the properties suggested as tests in Baker (2008) and his claims about Samba and Haya.

---

<sup>2</sup>There are some languages which apparently disallow any kind of doubling for some objects. In a number of cases, these are languages with obligatory object marking for a subclass of animate objects, including Nyaturu (Rimi) (Hualde 1989) and Ruwund (Nash 1992). These are discussed in section 3.3.2.

<sup>3</sup>Other tests discussed in Bresnan and Mchombo (1987) are discussed in section 3.3.1.

<sup>4</sup>For an Optimality Theory account of these kinds of phenomena see Woolford (1999, 2001).

## 3.2 Obligatory object marking

From a typological perspective, Corbett (2006) states that the canonical case for agreement is to be obligatory and context free. From a theoretical perspective, Baker (1988b) also argues that grammatical (syntactic) agreement is obligatory. This holds for subject agreement in Bantu, which is obligatory for all kinds of subjects whether or not they are overtly present. However, object marking in Bantu is dependent on whether or not the object is present, and then on the properties of the noun, and the syntactic environment, even in the languages which have obligatory object marking. This means that object marking in Bantu is not such a clear case, even for the languages where it is treated as agreement. However, according to Bentley (1994) and Woolford (1999), animacy effects are cross-linguistically very common.<sup>5</sup> The Bantu languages with obligatory object marking are the most obvious candidates for languages with object agreement. I will start by describing this pattern, before looking at whether or not there is evidence for dislocation of object-marked objects in section 3.3.

In Swahili, Chaga (Marten et al. 2007), Ruwund (Nash 1992), Makhuwa (van der Wal 2009) and Sambia, object marking is obligatory for certain types of nouns. I will look at obligatory and optional object marking in this section. Cases where co-occurrence is ungrammatical are discussed in section 3.3.2. In the first part, I show the way obligatory object marking works in Sambia and Swahili and the class of nouns which trigger this. The second part looks at whether this is connected to definiteness or specificity.

### 3.2.1 Obligatory object marking in Sambia and Swahili

**Sambia** In simple assertions with a single object, Sambia object marking appears in grades of acceptability: obligatory, preferred, optional, rare and ungrammatical. As will be shown here and in chapter 5, this is determined by the semantic features of the object noun.

In a simple transitive clause, the object must be object-marked if it is a proper name, as shown in (3a). Dropping the object marker is ungrammatical, as shown in (3b). The fact that the verb is conjoint here does not affect the grammaticality of object marking, a conjoint verb would show the same pattern. This is discussed in section 3.3.2.

- (3) a. N-      za-      mw-    ona Stella.  
       SM1S- PERF.DJ- OM1- see 1Stella  
       ‘I saw Stella.’
- b. \* N-      za-      ona Stella.  
       SM1S- PERF.DJ- see 1Stella  
       Int: ‘I saw Stella.’
- [Sambia]

<sup>5</sup>Within Optimality Theory, several accounts formalise these restrictions (see for example Aissen (2003) and Woolford (1999)).

The same requirement holds for kinship terms.<sup>6</sup> As shown in (4a), if the object marker is dropped as in (4b) the sentence is ungrammatical.

- (4) a. N-     za-     mw-   ona tate.  
       SM1S- PERF.DJ- OM1- see 1father.POSS.1  
       ‘I saw father.’  
   b. \* N-     za-     ona tate.  
       SM1S- PERF.DJ- see 1father.POSS.1  
       Int: ‘I saw father.’ [Sambaa]

Titles that are unique in a given context also behave like proper names and kinship terms. The pattern found with this pragmatically-determined class of nouns is also affected by pragmatic factors, such as politeness. For example, words referring to people with high status are object-marked consistently. In (5a) this is shown with the example of the word *askofu* ‘bishop’.<sup>7</sup> Again, dropping the object marker is ungrammatical, as shown in (5b). The plural form of the word for ‘bishop’ *maaskofu* does not have the unique reading. With the plural form object marking is optional, as shown in (5c).

- (5) a. N-     za-     mw-   ona askofu.  
       SM1S- PERF.DJ- OM1- see 5bishop  
       ‘I saw the bishop.’  
   b. \* N-     za-     ona askofu.  
       SM1S- PERF.DJ- see 5bishop  
       Int: ‘I saw the bishop.’  
   c. N-     za-     (wa-) ona maaskofu.  
       SM1S- PERF.DJ- OM2- see 6bishop  
       ‘I saw the bishops.’ [Sambaa]

Pronouns for first and second person also require object marking. This is illustrated with the first person singular pronoun *iwe* in (6a). Without the object marker, as in (6b), the sentence is ungrammatical. All free pronouns are emphatic in Sambaa and the sentence in (6a) would receive a contrastive focus reading. However, the third person pronoun does not require object marking in Sambaa, as shown in (6c).

- (6) a. N-     za-     ku-   ona iwe.  
       SM1S- PERF.DJ- OM2S- see you  
       ‘I saw YOU.’  
   b. \* N-     za-     ona iwe.  
       SM1S- PERF.DJ- see you  
       Int: ‘I saw you.’ or ‘I saw YOU.’<sup>8</sup>

<sup>6</sup>Like other kinship terms in many Bantu languages, there are several words for ‘father’ and ‘mother’ in Sambaa. Which word is used depends on the sex of the speaker and on the speaker’s relationship to the person referred to. For example *tate* means ‘my/our father’ while *ishe* means ‘his/her/their father’. Words for ‘mother’ work similarly.

<sup>7</sup>Nouns such as *askofu* which formally belong to a class other than 1/2 but denote humans always take class 1/2 agreement on verbs.

<sup>8</sup>With the reading where *iwe* is interpreted as ‘stone’ (class 5) the sentence would be grammatical. However, that reading is not relevant to the discussion of personal pronouns here.

- c. N-      za-      (mw)- ona uja.  
 SM1S- PERF.DJ- OM1- see 1DEM  
 ‘I saw HIM/HER.’<sup>9</sup> [Sambaa]

With other types of humans, object marking is common but not obligatory. This is illustrated in (7a). Object marking for nouns referring to animals is less common but entirely grammatical. An example of this is shown in (7b). Unlike in Swahili, nouns referring to animals tend to be in class 5/6 or 9/10, and object markers for this type of noun have the features of those classes, not class 1/2.<sup>10</sup> Object marking for nouns referring to inanimates is rare but acceptable, as shown in (7c).

- (7) a. N-      za-      (mw-) ona ng’wana.  
 SM1S- PERF.DJ- OM1- see 1child  
 ‘I saw the/a child.’  
 b. N-      za-      (ji-) ona kui.  
 SM1S- PERF.DJ- OM5- see 5dog  
 ‘I saw the/a dog.’  
 c. N-      za-      (chi-) ona kitezu.  
 SM1S- PERF.DJ- OM7- see 7basket  
 ‘I saw the/a basket.’ [Sambaa]

Thus, in a monotransitive sentence any semantic kind of object *can* be object-marked, while only a small subset of the nouns referring to humans *require* object marking. Properties such as being human, animate or inanimate also affect object marking. For ditransitives there are further restrictions which will be discussed in section 3.4.2 and chapter 5. In the next section, I will compare the categories are obligatorily object-marked in Swahili with those in Sambaa before discussing features such as animacy and definiteness in more detail in section 3.2.2.

**Swahili and Sambaa** In Swahili, object marking is obligatory with animate objects much more generally. This particularly hold for nouns referring to humans. In Swahili, unlike in Sambaa, object marking is obligatory for object nouns modified by a possessive that refer to a human, such as the sentence in (8).

- (8) a. Ni-      li-      mw- ona mwanawe.  
 SM1S- PAST- OM1- see 1child.POSS.3S  
 ‘I saw his child.’  
 b. \* Ni-      li-      ona mwanawe.  
 SM1S- PAST- see 1child.POSS.3S  
 Int: ‘I saw his child.’ [Swahili]

In Swahili, all animates trigger object marking with class 1/2. This includes nouns referring to animals, as shown in (9a). However, in contrast to (8b), dropping the object marker is acceptable here, even with an inherently definite modifier like a possessive.

<sup>9</sup>There are no special free pronouns third person entities in Sambaa, demonstratives are used instead.

<sup>10</sup>Across Bantu class 1/2 is used for humans.

- (9) a. Ni- li- mw- ona mbwa.  
SM1S- PAST- OM1- see 9dog  
'I saw the/a dog.'
- b. Ni- li- ona mbwa (wake).  
SM1S- PAST- see 9dog this  
'I saw the/a dog.'
- [Swahili]

In Sambia, only nouns referring to humans are likely to be object-marked and only nouns referring to humans appear with class 1/2 object marking. Other types of animates, such as nouns referring to animals, appear with object markers of the class that they grammatically belong to, for example class 5, as in (10a). Using a class 1 marker, as in Swahili, is ungrammatical, as shown in (10b). However, Sambia speakers prefer the equivalent sentence in Sambia without object marking, although its object-marked counterpart, shown in (10c), is not grammatically degraded.

- (10) a. Ni- za- ona kui.  
SM1S- PERF.DJ- see 5dog  
'I saw the/a dog.'
- b. \* Ni- za- mw- ona kui.  
SM1S- PERF.DJ- OM1- see 5dog  
Int: 'I saw the/a dog.'
- c. Ni- za- ji- ona kui.  
SM1S- PERF.DJ- OM5- see 5dog  
'I saw the/a dog.'
- [Sambia]

These kinds of restrictions have been formalised in the Bantu literature (Bentley 1994; Duranti 1979; Hyman and Hawkinson 1974; Morolong and Hyman 1977), and cross-linguistically (Aissen 2003; Croft 2003) as animacy and definiteness hierarchies. A basic animacy hierarchy is shown in (11).

- (11) human > animate > inanimate

In both Swahili and Sambia, human objects are different from other animate objects. In Sambia, this expresses itself in how common object marking is, whereas in Swahili the difference is the obligatoriness of object marking. There are differences between animate and inanimate objects in both languages. However, in Sambia, being a human object is not enough to trigger obligatory object marking. Neither is being a definite human object. However, in the literature, there are more fine-grained hierarchies which include reference to person and definiteness, such as the hierarchy shown in (12).

- (12) first/second person pronouns > third person pronoun > proper names >  
human common noun > non-human animate common noun >  
inanimate common noun (Croft 2003:130)

This hierarchy captures the Sambia data to an extent, when it comes to first and second (but not third) person pronouns and proper names, but a more careful analysis

of definiteness and specificity and object marking in the two languages is needed for the analysis of object marking. This will be developed in the next section.

### 3.2.2 **Definiteness and specificity**

In the discussion of obligatory object marking in Sambia and Swahili, we have seen that animacy plays a role in both languages. However, in Sambia, obligatory object marking is not only determined by animacy, another factor also plays a role. This factor is arguably definiteness. In this section, I will look at the way object marking interacts with definiteness and specificity, first in Swahili and Sambia and then in other Bantu languages. Regarding object marking, there are two key issues connected to definiteness and specificity. The first one is how obligatory object marking is affected by definiteness and specificity. The second issue is whether the object marker can be directly associated with definiteness or specificity by being required in order for a noun phrase to receive a definite or specific reading or by being ungrammatical with non-specific noun phrases. It will be shown that definiteness plays a role in determining obligatory object marking for animates in both languages, while not directly associated with object marking in either language.

Consider the separate animacy and definiteness hierarchy in Aissen (2003:437). The objects which are highest on both scales are obligatorily object-marked in Sambia, whereas in Swahili, all animate, and particularly human objects trigger object marking in the appropriate syntactic configuration, with definiteness showing little effect. However, when looking more carefully at different varieties of Swahili, the scale in (13b) does play a role.

- (13) a. Animacy Scale: Human > Animate > Inanimate  
 b. Definiteness Hierarchy: Proper name > Pronoun > Definite NP > Indefinite specific NP > Non-specific NP

In Bantu, definite noun phrases, indefinite noun phrases and non-specific noun phrases can all appear as bare nouns (nouns without any determiner, preposition or any other nominal modifier). There is no general definiteness marker in Bantu, nor a marker encoding specificity. Whether or not an NP is definite or specific is a question of interpretation and context in most cases. For the purpose of the discussion here, I define definiteness and specificity as shown in (14).

- (14) a. **Definiteness**: being uniquely identifiable or familiar to the hearer (Ward and Birner 1995)  
 b. **Specificity**: having a particular referent (Sio 2006)

There are types of entities which have a particular definiteness status. For example, proper names and pronouns, which appear in (13b) at the high end of the hierarchy, are inherently definite. Generally, but not always, nouns modified by determiners such as demonstratives and possessives are also definite. In fact, for many Bantu languages it has been argued that certain demonstratives can function like definite articles (for

example Besha 1989b for Smbaa, Ashton 1944 for Swahili, Nash 1992 for Ruwund and Doke 1931 for Zulu). This we can determine at least some types of NPs which are definite. There are also some clear cases at the other end of the scale. These include negative polarity items (NPIs) such as ‘any’ or words such as the Swahili word *fulani* ‘a certain person’ that is specific. We have already seen that in Smbaa and Swahili certain nouns marked by a possessive that receive a definite reading do not require object marking. With regard to object marking the question is whether there is a clear correlation between the presence or absence of object marking and definiteness or specificity. To answer this question, we will look at definite nouns and negative polarity items as a test case.

Definite objects do not require object marking to get the intended reading in the two languages discussed here. For example, in Smbaa, object marking with an inherently definite noun phrase is optional, as shown for a possessive noun phrase in (15a) and for a demonstrative in (15b).

- (15) a. N-    za-       (mw)- ona ng’wanae.  
SM1S- PERF.DJ- OM1- see 1child.POSS.3S  
‘I saw his child.’
- b. N-    za-       (mw)- ona uja ng’wana.  
SM1S- PERF.DJ- OM1- see that 1child  
‘I saw that child.’ [Smbaa]

Moreover, in Smbaa and Swahili, definite readings are available without object marking. This is shown for Swahili in (16a) and for Smbaa in (16b).

- (16) a. Ni-   li-       penda sana kitabu chake cha    kwanza.  
SM1S- PAST- like   much 7book 7her 7ASSOC first  
‘I liked her first book a lot.’ [Swahili]
- b. N-    za-       ona waja wana vituhu.  
SM1S- PERF.DJ- see 2DEM 2child again  
‘I saw those children again.’ [Smbaa]

For Swahili, the situation is more complex because of interdialectal variation. Certain speakers of Tanzanian Swahili, generally from mainland Tanzania, do not tend to use object marking for non-specific humans, as shown in (17a). Kiunguja<sup>11</sup> speakers tend to require object marking in those cases as well, as shown in (17b). Cases like the sentences in (17c) with certain collective plural nouns, and especially derogatory uses, are acceptable to most if not all speakers of Swahili.

- (17) a. Ni-   li-       ona mtoto.  
SM1S- PAST- see 1child  
‘I saw a child.’ [Mainland Tanzanian Swahili]

<sup>11</sup>Kiunguja is the Swahili dialect spoken in the Stonetown of Unguja island (Zanzibar) and surrounding areas but not in all parts of the island. (Tanzanian) Standard Swahili is based on this dialect, but there are some differences between the two variants.

- b. Ni- li- \*(mw)- ona mtoto.  
SM1S- PAST- OM1- see 1child  
'I saw a child.' [Kiunguja Swahili]
- c. Ni- li- ona maaskari.  
SM1S- PAST- see 6soldier  
'I saw soldiers.' [Swahili]

Swahili is a language with several million speakers. It is spoken in several countries, spread across a large geographic area, and there are a number of different dialects which vary with regard to when object marking is required. For these reasons, it is difficult to define the precise cut-off point for object marking. There is an extensive literature that touches on the question of whether or not Swahili object marking is obligatory (Amidu 2006; Seidel and Dimitriadis 1997; Wald 1979, 1997). According to the definition in (1b), Swahili has obligatory object marking because there are speakers who will reject sentences without object marking with certain types of overt lexical objects, and the kinds of objects which trigger obligatory object marking form a coherent semantic class.

In (Standard) Swahili and Sambia, object marking negative polarity items is grammatical, as shown in (18a) and (18b).

- (18) a. Si- ku- mw- ona mtu yeyote.  
NEG.SM1S- NEG.PAST- OM1- see 1person 1any  
'I didn't see anyone.' [Swahili]
- b. Si- chi- on- iye kintu chochoshe.  
NEG.SM1S- OM7- see- PERF.CJ 7thing 7any  
'I didn't see anything.' [Sambaa]

Some speakers of Mainland Swahili again differ from the judgement reflected in (18). For those speakers, the NPI reading is not available with object marking.

- (19) a. Si- ku- ona mtu (yeyote).  
NEG.SM1S- NEG.PAST- see 1person 1any  
'I didn't see anyone.'
- b. Si- ku- mw- ona mtu.  
NEG.SM1S- NEG.PAST- OM1- see 1person  
'I didn't see him/her.'
- c. ? Si- ku- mw- ona mtu yeyote.  
NEG.SM1S- NEG.PAST- OM1- see 1person 1any  
Int: 'I didn't see anyone.' [Mainland Swahili]

For Kiunguja speakers, (19a) is ungrammatical, as shown in (20).

- (20) \* Si- ku- ona mtu (yeyote).  
NEG.SM1S- NEG.PAST- see 1person 1any  
Int: 'I didn't see anyone.' [Kiunguja Swahili]

In conclusion, for Kiunguja Swahili speakers and Sambia speakers there is no direct correlation between the presence or absence of object marking and definiteness and specificity. Both object-marked and non-object-marked objects can be definite, specific or non-specific. In the variety of Mainland Swahili discussed here, specificity does play a role in object marking. In this dialect, object-marked objects are always specific, while non-specific objects cannot be object-marked. However, in both languages in general, the objects which appear at the top of the definiteness scale in (13b) must be object-marked.

**Definiteness and specificity in other Bantu languages** Turning to other Bantu languages, we see definiteness with respect to the presence or absence of object marking more generally. For example, in Nyaturu (F32), according to Hualde (1989), object marking is required for definite animate objects. With the object marker, the definite reading is available, as in (21a), but without it the noun is interpreted as indefinite, as in (21b). As in Sambia and Swahili, object marking is required for proper names and pronouns, as shown in (21c)-(21f).

- (21) a. N- a- mŭ- onaa mwalimu.  
SM1S- PAST1- OM1- see 1teacher  
'I saw the teacher.'
- b. N- a- onaa mwalimu.  
SM1S- PAST1- see 1teacher  
'I saw a teacher.'
- c. N- a- mŭ- onaa Maria.  
SM1S- PAST1- OM1- see 1Maria  
'I saw Maria.'
- d. \* N- a- onaa Maria.  
SM1S- PAST1- see 1Maria  
Int: 'I saw Maria.'
- e. N- a- kŭ- onaa (veve).  
SM1S- PAST1- OM2S- see you  
'I saw you.'
- f. \* N- a- onaa veve.  
SM1S- PAST1- see you  
Int: 'I saw you.'
- [Nyaturu, Hualde 1989:182]

The class of objects which trigger obligatory object marking is bigger in the Bantu language Ruwund (Ruund, L53). As Nash (1992) argues, in this language, object marking is required for all specific animates. This is rather similar to the pattern found in Mainland Tanzanian Swahili that was illustrated in (17). Example (22a) shows object marking with a specific animate object, (22b) shows object marking with a proper name, and (22c) shows a non-specific animate noun without object marking. In simple transitive clauses, object marking is optional with non-specific animates. Ditransitives show a different pattern, which I discuss in section 3.3.2.

- (22) a. ku- mu- kimb muntu  
 INF- OM1- look.for 1person  
 ‘to look for a/the person’ [Ruwund, Nash 1992:565]
- b. ku- \*(mu)- tàl Yâav  
 INF- OM1- visit 1Yaav  
 ‘to visit Yaav’ [Ruwund, Nash 1992:565]
- c. ku- kimb muntu  
 INF- look.for 1person  
 ‘to look for any person’ [Ruwund, Nash 1992:565]

In this section, we have seen how obligatory object marking interacts with definiteness in four Bantu languages. Each language shows a slightly different pattern in terms of where the cut-off point is for obligatory object marking is on the animacy and definiteness hierarchy and in terms of the association of object marking with definiteness or specificity. If we combine the relevant scales, somewhat like Croft does in (12), we end up with the distribution in (23).

- (23) first/second person pronouns > proper names (Sambaa) > definite human common noun (Nyaturu) > specific human common noun (Ruwund) > non-specific human common noun > non-human animate common noun (Swahili) > inanimate common noun

**Languages without definiteness effects** A different pattern appears in Makhuwa (P31), where all class 1/2 nouns regardless of their meaning require object marking (Stucky 1983 and van der Wal 2009). This is shown for an indirect object in (24a) and for a direct object of a monotransitive verb in (24b). This object marking pattern is highly unusual in the Bantu language family, with Makhuwa being the only language known to exhibit such a pattern. Classes 1 and 2 are the only classes for which object markers exist and this pair of classes includes inanimate nouns such as *báásikeli* ‘bicycle’. However, having inanimate nouns such as ‘bicycle’ in class 1/2 is also reported for other Bantu languages, for example Zulu (Leston Buell, p.c.).

- (24) a. Aráárima a- ho- ní- rúwélá mwááná isímá.  
 Araarima SM1- TNS- OM1- buy 1child porridge  
 ‘Araarima prepared porridge for the child.’ [Makhuwa, Stucky 1983:83]
- b. Aráárima a- ho- ní- th’úma báásikeli.  
 Araarima SM1- TNS- OM1- buy 1bicycle  
 ‘Araarima has bought a bicycle.’ [Makhuwa, Stucky 1983:83]

In Haya, object marking is never obligatory with an object which is lexically expressed. This is shown for a proper name in (25a) and for a first person (emphatic) pronoun in (25b). In (25a), the class 7 object marker *-ki-* cannot be dropped because the direct object is overtly expressed. The question of whether the optional doubling in Haya is actually local doubling or requires dislocation of the object is discussed in section 3.3.2.

- (25) a. N- ka- ki- (mu-) ha Kristina.  
 SM1S- PAST3- OM7- OM1- give Kristina  
 ‘I gave it to Kristina.’
- b. A- ka- (m-) bona inye.  
 SM1S- PAST3- OM1S- see me  
 ‘He saw me.’ [Haya]

Using the definition in (1b), five of the languages discussed in this section have obligatory object marking: Sambia, Swahili, Nyaturu, Ruwund and Makhuwa. Although Makhuwa is different from the others in terms of how the class of obligatorily object-marked entities is defined, all languages exhibit a coherent pattern for obligatory object marking. While the first four languages are geographically and genetically rather closely connected, Ruwund is spoken in a very different part of the Bantu speaking area and belongs to a different genetic subgroup. Haya, was presented as an example of the Bantu languages which do not have any semantically or syntactically defined class of object nouns which must be object-marked. The categories associated with obligatory object marking and definiteness in the languages mentioned here are summarized in table 3.1.

Table 3.1: Categories which trigger obligatory object marking per language

Property	Sambia	Swahili	Nyaturu	Ruwund	Makhuwa	Haya
1/2PERS pron.	yes	yes	yes	yes	yes	no
proper names	yes	yes	yes	yes	yes	no
def. humans	no	yes	yes	yes	no	no
spec. humans	no	yes	yes	no	no	no
humans	no	yes	no	no	no	no
animates	no	yes	no	no	no	no
class 1/2	no	(yes)	no	no	yes	no

### 3.3 Object marking and dislocation across Bantu

As shown in the previous section, there are two macro-patterns with regard to object marking: a group of languages which require object marking for certain classes of nouns and languages like Haya which do not. For Haya and similar languages, it has been proposed that these languages do not allow doubling at all. This does not mean that in those languages sentences with an object marker and an object following the verb are ungrammatical, but rather that in such cases the object is dislocated to a position outside of the verb phrase. This is illustrated with a well-known example from Bresnan and Mchombo (1987). In (26a), there is no object marking and the object is argued by Bresnan and Mchombo (1987) to be the argument of the verb, whereas in (26b) the object is argued to be a topic and dislocated.

- (26) a. Ndi- ku- fúná kutí áná ánga [a- pitirizé phúnziro]  
 SM1S- PRES- want that 2child 2my SM2- continue.SUBJ 5lesson  
 ‘I want my children to continue the lesson.’
- b. Ndi- ku- fúná kutí áná ánga [a- li- pítírize] phúnziro  
 SM1S- PRES- want that 2child 2my SM2- OM5- continue.SUBJ 5lesson  
 ‘I want my children to continue it, the lesson.’
- [Chichewa, Bresnan and Mchombo 1987:750]

The evidence supporting such analyses is generally based on two things: tones marking phrase boundaries, as in (26b) or conjoint/disjoint alternation effects, as shown in (27). In languages like Zulu, a disjoint form must be used where an object and co-indexed object marking co-occur (Buell 2005; van der Spuy 1993). An example of the conjoint/disjoint alternation interacting with object marking is shown in (27).

- (27) a. Ba- thanda ibhola.  
 SM2- like.PRES.CJ football  
 ‘They like football.’ [Zulu, van der Spuy 1993:340]
- b. Ba- ya- li- thanda (ibhola).  
 SM2- PRES.DJ- OM- like football  
 ‘They like football.’ [Zulu, van der Spuy 1993:340]

It is not clear *where* the object is in those cases. In the literature the following positions are suggested:

- Zulu: van der Spuy (1993) - outside of IP<sup>12</sup>
- Chichewa: Bresnan and Mchombo (1987) - in a topic position outside of VP (which corresponds to TP/IP in a Minimalist structure)
- Haya: Byarushengo et al. (1976), Tenenbaum (1977) - right-dislocated

As shown below, these positions are problematic for the word order properties of object-marked objects in Haya, and to an extent also for the Chichewa analysis.

In the previous section, obligatory object marking was discussed. In this section, I discuss the question of whether object-marked objects must be dislocated in particular Bantu languages. If a language has obligatory object marking, and there is no evidence that object-marked objects are dislocated, object marking should be analysed as agreement. However, even without obligatory object marking, allowing object-marked objects which are not dislocated in my view qualifies a language as an agreement language. The discussion starts by reviewing the analysis of object markers in Chichewa as incorporated pronouns proposed in Bresnan and Mchombo (1987). In their analysis various types of evidence for dislocation are proposed. In the subsequent sections, it is shown that, in Sambiaa, object-marked objects do not show any evidence for dislocation. In the final part of the section, the evidence for right-dislocation of Haya object-marked objects is reviewed and a range of new data related to right-dislocation

<sup>12</sup>Recent analyses of Zulu consider very low adjunction as well (Buell 2008; Cheng and Downing 2009).

is introduced. It is argued that because the right-dislocation analysis must be rejected, the hypothesis that Sambia and Haya are fundamentally different with regards to object marking must also be rejected. Both languages can be treated as agreement languages because neither language requires dislocation of object-marked objects.

### 3.3.1 Bresnan and Mchombo (1987)

Bresnan and Mchombo (1987) argue that object marking is always pronominal in Chichewa. This is influenced by their use of Lexical Functional Grammar (LFG), which allows no empty categories or movement (Bresnan 2001). Since LFG is a theory which has no empty pronominal positions, not all their arguments hold in the Minimalist Program, since agreement with a covert head is ruled out by LFG on principle. In Bresnan and Mchombo's framework, object marking is "anaphoric agreement" when the object is not overt and "grammatical agreement" when the object is overt and local. This means that in such a system all Bantu languages allow "anaphoric agreement" but not all Bantu languages allow "grammatical agreement". "Anaphoric agreement" in this case, means that the object marker is an incorporated pronoun, and thus derived via a process which is not related to agreement at all in a Minimalist framework. "Grammatical agreement", on the other hand, corresponds to the notion of agreement in most Minimalist frameworks. For Chichewa, they argue that object marking is always anaphoric as the object is always right-dislocated when it appears to double an object marker. They use word order, optionality, tone patterns, object marking with in situ *wh*-questions and relative clauses as evidence for their analysis. For Swahili and Makhuwa, they argue that object marking is agreement-like because it is obligatory with some categories of nouns, and can be used with in situ object questions. In Chichewa, object marking is always optional, unlike in Swahili and Makhuwa.

Bresnan and Mchombo (1987) argue that local doubling is ungrammatical in Chichewa by demonstrating the existence of a tonal pattern which marks the end of the VP.<sup>13</sup> This tone pattern is the realisation of a falling tone on the penult of the object-marked verb if it has an underlying high tone on the final vowel, in certain environments, as shown by the contrast between (28a, repeated from (26)) and (28b). In (28a), there is no object marker co-indexed with *phunziro*, and there is no falling tone on the penult of the verb, in (28b), where there is object marking, the falling tone on the penult can be seen.

- (28) a. Ndi- ku- fúná kutí áná ańga [a- pitirizé phúnziro]  
 SM1S- PRES- want that 2child 2my SM2- continue.SUBJ 5lesson  
 'I want my children to continue the lesson.'

[Chichewa, Bresnan and Mchombo 1987:750]

<sup>13</sup>There is also evidence from lengthening of the penult which Bresnan and Mchombo (1987) mention but do not indicate in their data.

- b. Ndi- ku- fúná kutí áná ańga [a- li- pítíríze] phúnziro  
 SM1S- PRES- want that 2child 2my SM2- OM5- continue.SUBJ 5lesson  
 ‘I want my children to continue it, the lesson.’  
 [Chichewa, Bresnan and Mchombo 1987:750]

Bresnan and Mchombo (1987) make a distinction between free pronouns, which they argue are used to introduce new topics or to contrast arguments, and the object marker, which is only anaphoric. An object marker can resume a topicalized constituent, as shown in (29a), whereas a free pronoun cannot, as shown in (29b).

- (29) a. Mkángo uwu físi a- ná- ú- dya.  
 3lion 3DEM hyena SM- PAST- OM3- eat  
 ‘This lion, the hyena ate it.’  
 [Chichewa, Bresnan and Mchombo 1987:769]
- b. \*? Mkángo uwu físi a- ná- dyá iwo.  
 3lion 3DEM hyena SM- PAST- eat 3it  
 Int: ‘This lion, the hyena ate it.’  
 [Chichewa, Bresnan and Mchombo 1987:769]

However, it is not clear that this is a property related to object marking, rather than a property of free pronouns, which are often emphatic in Bantu. Free pronouns tend to be used with contrastive focus, which would also not be expected to be able to resume a topicalized constituent. In Sambia, which does not require object marking with nouns referring to animals, and which has the obligatory object marker system rather than the non-doubling system, the same effect is observed. With object marking the sentence is acceptable, as shown in (30a), whereas with a demonstrative the sentence is ungrammatical.<sup>14</sup>

- (30) a. Inu shimba, físhi a- za- i- ja.  
 9DEM 9lion 9hyena SM1- PERF.DJ- OM9- eat  
 ‘This lion, the hyena ate it.’
- b. \* Inu shimba, físhi a- za- ja iyo.  
 9DEM 9lion 9hyena SM1- PERF.DJ- eat it  
 Int: ‘This lion, the hyena ate it.’ [Sambia]

In Chichewa, an object marker can resume the head of a relative clause as shown in (31a), whereas a free pronoun cannot, as shown in (31b). Likewise, in a cleft the object marker can resume the clefted constituent as shown in (31c), whereas a free pronoun cannot, as shown in (31d).

- (31) a. Ndi- ku- lírira mkango uméné físi a- ná- ú- dya.  
 SM1S- PRES- cry.APPL 3lion 3REL hyena SM- PAST- OM3- eat  
 ‘I’m crying for the lion that the hyena ate.’  
 [Chichewa, Bresnan and Mchombo 1987:769]

<sup>14</sup>Note the unusual agreement pattern here for the subject marker. In Sambia, animals in fairy tales or more agentive roles sometimes trigger class 1/2 agreement. Corbett (2006) refers to this kind of variation as semantic and syntactic agreement.

- b. \*? Ndi- ku- lírira mkango uméné fisi a- ná- dya iwo.  
 SM1S- PRES- cry.APPL 3lion 3REL hyena SM- PAST- eat 3it  
 Int: 'I'm crying for the lion that the hyena ate.'  
 [Chichewa, Bresnan and Mchombo 1987:769]
- c. Sí m̀kángó uwu uméne fisi á- ná- ú- dya.  
 NEG.COP 3lion 3DEM 3REL hyena SM- PAST- OM3- eat  
 'It's not the lion that the hyena ate.'  
 [Chichewa, Bresnan and Mchombo 1987:769]
- d. \*? Sí m̀kángó uwu uméne fisi á- ná- dya iwo  
 NEG.COP 3lion 3DEM 3REL hyena SM- PAST- eat 3it  
 Int: 'It's not the lion that the hyena ate.'  
 [Chichewa, Bresnan and Mchombo 1987:769]

These effects are interesting but may be caused by the focal properties of free pronouns in Bantu. The paradigms of object marking in relative clauses and questions is very complex and does not map onto the two types of Bantu language discussed so far. These patterns will be discussed in chapter 6.

Like the rest of Bantu (with the exception of Tunen, Bearth (2003), based on Mous (1997)), the basic word order in Chichewa is SVO, as shown in (32a). Without object marking this order cannot be reversed, as shown in (32b). However, with object marking the order is grammatical, as shown in (32c). In fact, any order of the three constituents is grammatical with object marking.

- (32) a. Njũchi zi- ná- wá- lúma alenje.  
 10bees SM10- PAST- OM2- bite 2hunter  
 'The bees bit the hunters.' [Chichewa, Bresnan and Mchombo 1987:744]
- b. \* Alenje zi- ná- lúma njũchi.  
 2hunter SM10- PAST- bite 10bees  
 'The bees bit the hunters.' [Chichewa, Bresnan and Mchombo 1987:745]
- c. Alenje zi- ná- wá- lúma njũchi.  
 2hunter SM10- PAST- OM2- bite 10bees  
 'The bees bit the hunters.' [Chichewa, Bresnan and Mchombo 1987:745]

Bresnan and Mchombo (1987) use this as evidence for the non-object status of an object-marked object. However, for the subject and the object, reordering is also possible in Samba and Swahili. This means that this test fails to distinguish between the languages with supposedly different types of object marking.

For simple transitives in Chichewa, the phonological evidence is compelling in spite of the criticisms expressed here of some of the arguments presented in Bresnan and Mchombo (1987). However, when turning to double object constructions, more serious problems for their analysis are revealed. If a non-object marked object is sentence internal while an object-marked object is external, it should be ungrammatical for a non-object marked object to precede an object-marked one. However, as Henderson (2006b) points out, the sentence in (33) is not entirely ungrammatical. In fact,

in their footnote 12, Bresnan and Mchombo (1987:751) acknowledge this problem by saying that “The word order possibilities with some double-object verbs are more complex.” Moreover, Henderson claims that sentences like (33) are produced spontaneously by his language consultants.

- (33) ?? Ndi- ku- funa kuti mu- wa- pats- é alenje mphantso.  
 SM1S- PRES- want that SM2P- OM2- give SUBJ 2hunter 3gift  
 ‘I want that you give the hunters a gift.’

[Chichewa, Henderson 2006b:171, translation modified]

The right-dislocation analysis, proposed in Bresnan and Mchombo (1987), is further challenged by data from temporal adverbials. According to Henderson, there is a prosodic difference between the order O Adv and Adv O in Chichewa. An object-marked object which follows a temporal adverbial (Adv O order) is separated from the rest of the clause by an intonation break, whereas if the object-marked object precedes the temporal adverbial (O Adv order) there is no break. For the Chichewa example in (34), Henderson (2006b:172) claims that there is a clear intonation break between *dzulo* and *alenje* in (34a), but not in (34b).<sup>15</sup> For Henderson, the presence of the break marks a structure with a right-dislocated element. Based on this, Henderson (2006b:172) argues that only the object in (34a) is right-dislocated while the object in (34b) is local. I will discuss these kinds of examples for Haya below, taking a similar view to Henderson’s.

- (34) a. Ndi- na- funa kuti mu- wa- pats- é mphantso dzulo, alenje.  
 SM1S- PST- want that SM2P- OM2- give SUBJ 3gift yesterday 2hunter  
 ‘I wanted you to give them a gift yesterday, the hunters.’

[Chichewa, Henderson 2006b:171, translation modified]

- b. Ndi- na- funa kuti mu- wa- pats- é mphantso alenje dzulo.  
 SM1S- PST- want that SM2P- OM2- give SUBJ 3gift 2hunter yesterday  
 ‘I wanted you to give the hunters a gift yesterday.’

[Chichewa, Henderson 2006b:171, translation modified]

If the patterns reported in Henderson (2006b) hold for Chichewa in general, Chichewa does not require object-marked objects to be right-dislocated and might in fact be analysed as an agreement language. In any case, this data weakens the argument that object marking has a different syntactic status in Swahili and Chichewa respectively.

In this section, I have sketched some of the evidence presented to support the pronominal analysis of Chichewa object marking and some problems with it. In the next section, I will look at co-occurrence restrictions in different Bantu languages and evidence for it, including the conjoint/disjoint alternation and boundary tones. These sections provide the background to section 3.3.3, by developing a set of properties associated with local objects in Bantu. In 3.3.3, the issues introduced here will be taken up and discussed in more detail with regard to an analysis of Haya objects as right-dislocated.

<sup>15</sup>The prosodic break in (34a) is marked by a comma after *dzulo*.

### 3.3.2 Local doubling

Whether an object marker can co-occur with a local lexical object is potentially an important criterion for determining the syntactic status of the object marker. An agreement marker would be expected to be able to co-occur freely with a lexical object, while a pronominal clitic would not. Co-occurrence, in the sense relevant here, applies to all objects which appear to be in their base position or within TP/IP, not to left-dislocated or right-dislocated “objects”. The key question here is how to define a local object. Languages which could be said to ban local doubling are those which display prosodic or morphological indicators of boundaries between an object-marked verb and a co-indexed noun phrase. Cross-linguistically, this assumption is not always made. For example, for the Romance languages where clitic doubling occurs, clitics are most commonly treated as pronominal elements, even though clitic doubling is obligatory for certain objects in particular contexts, just like in the Bantu languages with obligatory object marking. However, there are some other approaches to this distinction for Bantu as well. For example, Woolford (1999, 2000, 2001) makes a distinction based on whether an object has to move in order to agree, which triggers similar effects to the dislocation of the lexical object required by the pronominal object marking analysis (Bresnan and Mchombo 1987 and many others).

As shown in section 3.2, there are Bantu languages where it is obligatory for certain objects to co-occur with a co-indexed object marker. The languages with this pattern include Sambia, Swahili, and Chaga and a number of Tanzanian languages, possibly due to the influence of Swahili on these languages. However, beyond the patterns discussed above, there are Bantu languages with more fine-grained co-occurrence restrictions, including Ruwund, Nyaturu. These languages require doubling for some types of objects and disallow it for others. As discussed above, another group of Bantu languages is argued to allow co-occurrence only with the dislocation of an object, this includes Chichewa (Bresnan and Mchombo 1987), Haya (Byarushengo et al. 1976), Sesotho (Demuth and Harford 1999), and Zulu (Buell 2005).

Henderson (2006b) proposes co-occurrence restrictions as a test for object agreement in Bantu languages. He claims that no Bantu language which allows more than one object marker allows co-occurrence of the lexical object and the object marker (but see Marten et al. 2007). This would rule out both Sambia and Haya as agreement languages. I will show in the first part of this section that there is no connection between the number of object markers and co-occurrence restrictions since all possible combinations of the two properties are found amongst Bantu languages. Languages with multiple object marking sometimes allow co-occurrence and sometimes not, and both patterns are also found amongst the languages that allow only one object marker.

After the discussion multiple object markers and doubling, four properties which are associated with local objects in Bantu will be established. These are the following:

- Local objects may trigger obligatory object marking.
- Local objects may appear with the conjoint form when object-marked.
- Local objects may appear in a fixed syntactic position.

- Local objects do not trigger phonological marking of phrase boundaries.

### Co-occurrence and multiple object markers

In this section, I discuss languages with multiple object markers and show that these allow doubling. After discussing a number of examples, we return to the Bantu languages which only allow one object marker, such as Nyaturu, which does not allow co-occurrence.

As (35) shows, Sambia is a counterexample to Henderson's typological claim. The lexical DPs expressing the direct object, the indirect object and the locative are all doubled by object markers. In Sambia, all types of lexical objects or locatives may co-occur with an object marker in double object constructions. In fact, for object marking with locatives, as in (35), doubling is preferred.

- (35) N-    za-       ha-    chi-  m-   nka Stella kitabu haja.  
 SM1S- PERF.DJ- OM16- OM7- OM1 give 1Stella 7book 16DEM  
 'I gave Stella a book there.' [Sambia]

Ha appears to be another counterexample to Henderson's claim. According to Harjula (2004:132), Ha allows only two object markers. A sentence with two object markers is shown in (36a). In (36b) the indirect object, which is object-marked, follows the direct object. However, the same word order is observed in the (36c) example without object marking. Moreover, there are no apparent phrase-level tone changes indicating that *umuáana* 'child' might have been extraposed.

- (36) a. Ya-       wu-   mú-   haa- ye.  
 SM1.REM- OM3- OM1- give- PERF  
 'She gave it to him.' [Ha, Harjula 2004:133]
- b. Ya-       mú-   haa- ye   umukáaté umuáana.  
 SM1.REM- OM1- give- PERF 3bread 1child  
 'She gave the child bread.' [Ha, Harjula 2004:133]
- c. Ya-       háa- ye   umukáaté umuáana.  
 SM1.REM- give- PERF 3bread 1child  
 'She gave the child bread.' [Ha, Harjula 2004:132]

Yet another counterexample is the Musumban dialect of Ruwund (as discussed in Nash 1992, Woolford 2001), which also allows multiple object markers and the co-occurrence of object markers and lexical objects. Ruwund allows at least three object markers, as shown in (37).<sup>16</sup> The locative marker *-ku* is a suffix here.<sup>17</sup>

<sup>16</sup>*-ku-* marks the second person singular and *-aañ* is a plural suffix (Nash 1992:566 fn.4).

<sup>17</sup>Locative suffixes are used in some dialects of Haya, and in the languages in the Lacustrine Group more generally. However, in some dialects of Ruwund non-locative object markers can also be suffixed. From the data presented in Nash (1992), it is not clear whether these may have any different morphosyntactic restrictions to the prefixed object markers.

- (37) ku- ka- ji- ku- sendang- aañ- ku  
 INF- go- OM10- OM2S- carry.from.regularly- 2PLURAL- OM17  
 ‘to regularly go and carry them off from you there’  
 [Musumban Ruwund, Nash 1992:564]

In double object constructions in Ruwund, doubling an object marker with a local object is only possible for the indirect object and only if it is animate. Moreover, in a double object construction, an animate indirect object must be object-marked. An example of this is shown in (38). This means that Ruwund also contradicts Henderson’s claim.

- (38) a. ku- mu- tiil muntu mupit  
 INF- OM1- set 1person trap  
 ‘to set a trap for a [any or particular] person’ [Ruwund, Nash 1992:565]

In Ruwund, like in Sambia, proper names or free pronouns require object marking, as was shown in section 3.2. With other humans object marking is required for specific nouns, according to Nash (1992)<sup>18</sup>. Unlike in Sambia the same holds for other animates, as shown in (39a) for a definite object and in (39b) for a non-specific object.

- (39) a. ku- yi- kàt atûbu  
 INF- OM4- like 4dog  
 ‘to like the dogs’ [Ruwund, Nash 1992:565]  
 b. ku- kàt atûbu  
 INF- like 4dog  
 ‘to like dogs’ [Ruwund, Nash 1992:565]

In Ruwund, object marking of inanimate objects is rare and according to Nash “exclude an indefinite reading of the noun” (Nash 1992:565). As the translation in (40a) shows, a definite reading is possible without an object marker, and as shown in the (40b) with an object marker only the definite reading of the noun is available. However, doubling an inanimate object is grammatical in simple transitive clauses.

- (40) a. ku- land malong  
 INF- buy 6plate  
 ‘to buy some/the plates’ [Ruwund, Nash 1992:565]  
 b. ku- ma- land malong  
 INF- OM6- buy 6plate  
 ‘to buy the plates’ [Ruwund, Nash 1992:565]

This is not the case in double object constructions. In (41), there are two object markers: *ma* class 6 (referring to an inanimate plural direct object) and the object marker *mu* class 1 (agreeing with the NP *mwaâan* ‘child’). According to Nash, doubling of the indirect object is required if it is animate (41).

<sup>18</sup>Nash speaks of nouns with a particular referent.

- (41) ku- ma- mu- tumin mwâan  
 INF- OM6- OM1 send.APPL 1child  
 ‘to send them to the child’ [Musumban Ruwund, Nash 1992:963]

Doubling is not obligatory for an inanimate indirect object, as (42a) shows, but it is grammatical, as shown in (42b). The direct object cannot be object-marked without object-marking the indirect object, as illustrated in (42c) and (42d). This is like the Sambia pattern, however, in Ruwund, if the direct object is inanimate, doubling it is ungrammatical, as shown in (42e).

- (42) a. ku- landin cikùmbu ulààl  
 INF- buy.APPL 7house 14bed  
 ‘to buy the bed for the house’ [Musumban Ruwund, Nash 1992:963]
- b. ku- ci- landin cikùmbu ulààl  
 INF- OM7- buy.APPL 7house 14bed  
 ‘to buy the bed for the house’ [Musumban Ruwund, Nash 1992:963]
- c. \* ku- wu- landin cikùmbu  
 INF- OM14- buy.APPL 7house  
 Int: ‘to buy the bed for the house’ [Musumban Ruwund, Nash 1992:963]
- d. ku- wu- ci- landin cikùmbu  
 INF- OM14- OM7- buy.APPL 7house  
 ‘to buy it for the house’ [Musumban Ruwund, Nash 1992:965]
- e. \* ku- wu- ci- landin cikùmbu ulààl  
 INF- OM7- OM14- buy.APPL 7house 14bed  
 Int: ‘to buy the bed for the house’ [Musumban Ruwund, Nash 1992:965]

Ruwund is an asymmetric language with animacy effects. In Ruwund, there are thus two factors which determine object marking patterns in double object constructions: animacy and argument structure. As I have shown in this section, the way animacy affects monotransitives differs from the way animacy affects ditransitives. The Ruwund data is particularly interesting because there is no clear reason why the agreement-like object marker should be sensitive to whether an object is lexically expressed or not, unless one were to treat object markers referring to inanimates as having a different syntactic status from those referring to animates. This is in fact what Nash does, by treating the non-doubled objects as pronouns.

**Single object marker languages** In Swahili, which allows only one object marker, doubling is freely acceptable for inanimates, as shown in (43a) for indirect object of a ditransitive. Two object markers are ungrammatical, as shown in (43b), and doubling the direct object in a ditransitive construction is also ungrammatical.<sup>19</sup>

- (43) a. Ni- me- m- pa Juma vitabu vyote vitatu pale.  
 SM1S- PERF- OM1- give 1Juma 8book 8all 8three 16there  
 ‘I have given Juma all three books there.’

<sup>19</sup>How this corresponds to other asymmetric properties and how it compares to the other languages discussed here will be shown below in section 3.4.3.

- b. \* Ni- me- vi- m- pa Juma vitabu vyote vitatu pale.  
 SM1S- PERF- OM8- OM1- give 1Juma 8book 8all 8three 16there  
 Int: 'I have given Juma all three books there.'
- c. \* Ni- me- vi- pa Juma vitabu vyote vitatu pale.  
 SM1S- PERF- OM8- give 1Juma 8book 8all 8three 16there  
 Int: 'I have given Juma all three books there.' [Swahili]

As shown above, Nyaturu allows, and in certain cases requires, doubling of an animate direct object, as shown in (44a). However, doubling is ungrammatical for an inanimate object such as *kitabu* 'book', as shown in (44b).

- (44) a. N- a- mū- onaa mwalimu.  
 SM1S- PAST1- OM1- see 1teacher  
 'I saw the teacher.' [Nyaturu, Hualde 1989:182]
- b. \* N- a- kɪ- onaa kitabu.  
 SM1S- PAST1- OM7- see 7book  
 Int: 'I saw the book.' [Nyaturu, Hualde 1989:182]

The languages that allow multiple object markers shown here display two patterns. Sambia has free doubling Sambia and Ruwund has restricted doubling. Furthermore, we see that the languages that allow only a single object marker allow the same patterns: Swahili which allows free doubling, Nyaturu which allows restricted doubling. Lastly, there are languages like Chichewa which, as discussed earlier, is argued not to allow (local) doubling. This indicates that, contra to what is proposed in Henderson (2006b), allowing multiple object markers does not affect the grammaticality of doubling an object marker with a local object in any way. However, there is a more interesting pattern which becomes apparent from the data in this section. The languages where an object co-occurring with an object marker in the same sentence is ungrammatical are Ruwund and Nyaturu, which also have obligatory object marking. As in other cases of differential object marking, these languages have object marking which is obligatory, optional and ungrammatical.<sup>20</sup>

### The conjoint/disjoint alternation and object marking

One piece of evidence for the dislocation of object-marked objects was the conjoint/disjoint alternation in languages like Zulu. The conjoint/disjoint alternation was introduced in chapter 2 for Sambia in terms of its morphosyntax. It is marked with the tense-aspect morphology, including tone in Bantu in general. The factors conditioning the conjoint/disjoint alternation are focus and constituency (Buell 2005, Buell 2006).<sup>21</sup> The conjoint form of the verb will be used if it appears in verb-phrase-internal positions while a disjoint form will be used if it appears in the verb phrase-final-position. If object marking is pronominal and therefore requires dislocation of a co-indexed

<sup>20</sup>The term differential object marking is most commonly used for case marking languages, such as Hindi/Urdu or Turkish (see Aissen 2003; de Hoop and Lamers 2006; de Swart 2007). In the Bantu literature, the term is not widespread but is used the work of Morimoto, for example Morimoto (2002).

<sup>21</sup>The interaction of the conjoint/disjoint alternation with focus is discussed in chapter 6.

object, two predictions follow from this: a transitive verb should never appear in the disjoint form without object marking, whereas a conjoint verb form should never appear with object marking and a local object.<sup>22</sup> If object marking is agreement-like this is not predicted to be the case. Rather, both local and non-local objects are predicted to agree in the same way.

Sambaa allows object marking to double a lexical object with both conjoint and disjoint verb forms. This is shown for the conjoint form in (45a) and for the disjoint form in (45b).

- (45) a. A- chi- som- iye kitabu.  
SM1- OM7- read- PERF.CJ 7book  
'He read the book.'
- b. A- za- chi- soma kitabu.  
SM1- PERF.DJ- OM7- read 7book  
'He read the book.'
- [Sambaa]

However, a non-object-marked object can appear after a disjoint form with or without object marking as shown in (46a) and (46b).

- (46) a. N- za- dikiya wana.  
SM1S- PERF.DJ- cook.APPL 2child  
'I cooked for the children'
- b. N- za- wa- dikiya wana.  
SM1S- PERF.DJ- OM2- cook.APPL 2child  
'I cooked for the children'
- [Sambaa]

The distribution of the disjoint form in (46) differs from what is reported for many other languages with the conjoint/disjoint distinction. For example, in Zulu, a conjoint form cannot be used with object marking and a local object, as shown in (47a), the grammatical version without object marking is shown in (47b).

- (47) a. \*Ngi- m- nik- e uThembi imali.  
SM1S- OM1- give- PERF.CJ 1Thembi 9money  
Int: 'I gave Thembi some money.' [Zulu, Buell and Riedel 2008:7]
- b. Ngi- nik- e uThembi imali.  
SM1S- give- PERF.CJ 1Thembi 9money  
'I gave Thembi some money.' [Zulu, Buell and Riedel 2008:7]

A disjoint form, on the other hand, cannot be used in a transitive verb without object-marking the object, as is shown in the alternation between (48a) and (48b). For Zulu, it has been argued based on this kind of evidence that the disjoint form of the verb indicates a verb in VP-final position (Buell 2006).

<sup>22</sup>This predication only holds if it is true for all Bantu languages that the disjoint form is strongly associated with phrase-finality.

- (48) a. Abafana ba- ya- yi- cula ingoma.  
 2boy SM2- PRES.DJ- om9- sing 9song  
 ‘The boys are singing a song.’ [Zulu, Buell 2006:14]
- b. \* Abafana ba- ya- cula ingoma.  
 2boy SM2- PRES.DJ- sing 9song  
 Int: ‘The boys are singing a song.’ [Zulu, Buell 2006:14]

In languages like Zulu, the conjoint/disjoint distribution does seem to support a right-dislocation analysis of object-marked objects. In Sambia, the grammaticality of a conjoint form with an object doubled by an object marker supports an analysis in terms of local doubling. Apart from obligatory object marking, the ability of an object-marked object to follow a verb in the conjoint form can be used as second property of local doubling.

### VP boundary tones and object marking

The other type of phonological evidence for dislocation as boundary tones in languages like Chichewa. As shown for Chichewa above, in some Bantu languages doubling triggers a prosodic break between the vP and the lexical noun phrase. In a language with object agreement such patterns should be absent. This holds true for Sambia. In fact, in Sambia, there is evidence against such a break before a doubled object. High tones can spread within the vP from the verb (if it has a final high tone) onto its complements up to the penultimate vowel (Odden 1982). This process happens with and without object marking. *Kítábù* ‘book’ has the underlying tone pattern LHL. This is the pattern realised in (49a) where the verb ends in a low tone. With High Tone Spread the vowel of the noun class prefix of the object noun is realised with a high tone in (49b and c) while the underlyingly high tone on the penult is downstepped (indicated with an exclamation mark).

- (49) a. Nì- kúnd -à kítábù.  
 SM1S- want- PRES.CJ 7book  
 ‘I want a book.’
- b. Nì- ghùl- íyé kít<sup>!</sup>ábù.  
 SM1S- buy- PERF.CJ 7book  
 ‘I bought the book.’
- c. Nì- chí- ghúl- íyé kít<sup>!</sup>ábù.  
 SM1S- OM7- buy- PERF.CJ 7book  
 ‘I bought the book.’ [Sambia]

In Sambia, right-dislocation is marked by a clearly audible pause. This becomes very clear where an object-marked indirect object appears after the direct object. Without a pause, the sentence is ungrammatical, as in (50a). However, with a pause (indicated by the comma), as in (50b), and right-dislocated interpretation, the sentence is grammatical.

- (50) a. \* N-    za-    m    nka kitabu Stella.  
           SM1S- PERF- OM1- give 7book 1Stella  
           Int: 'I gave Stella a book.'
- b. N-    za-    m    nka kitabu, Stella.  
           SM1S- PERF- OM1- give 7book 1Stella  
           'I gave her a book, Stella that is.' [Sambaa]

There is no tone spread across such a break. The relevant paradigm is illustrated in (51). In (51a), the object *ng'òmbè*, which underlyingly has two low tones, is object-marked but not right-dislocated. Because it is not dislocated, High Tone Spread applies and the object is realised with a high tone on the penult. In (51b), the object is right-dislocated, and accordingly *ng'òmbè* 'cow' is realised with low tones. Here, *ng'òmbè* gets an afterthought reading.

- (51) a. N-    zà-    í-    óná ng'ómbè.  
           SM1S- PERF.DJ- OM9- see 9cow  
           'I saw the cow.'
- b. N-    zà-    í-    óná, ng'òmbè.  
           SM1S- PERF.DJ- OM9- see 9cow  
           'I saw it, the cow.' [Sambaa]

The tone patterns shown in this section match the evidence from the conjoint/disjoint patterns in Sambaa and provides evidence supporting the idea that object marking does not require dislocation in Sambaa. These kinds of tonal patterns can be used as a third property of local objects.

### Word order and object marking

In Sambaa, objects which are doubled by object marking have the same distribution as their non-object-marked counterparts. An indirect object precedes a direct object, irrespective of whether or not it is object-marked. The grammatical order is shown in (52a) and its ungrammatical counterpart in (52b).

- (52) a. N-    za-    (m)- nka ng'wanafunzi kitabu.  
           SM1S- PERF- OM1- give 1student    7book  
           'I gave the student a book.'
- b. \* N-    za-    (m)- nka kitabu ng'wanafunzi.  
           SM1S- PERF- OM1- give 7book 1student  
           Int: 'I gave the student a book.' [Sambaa]

Word order can be established as the fourth property that locally doubled objects in Bantu might be expected to have.

### Conclusions

The data reviewed in this section provide evidence that in Sambaa there is no syntactic or prosodic break between a verb with object marking and a co-referential object. In

a basic SVO/SV IO DO assertion, doubled and non-doubled objects behave alike in Sambia. Four diagnostics have been used to establish Sambia as a language with local objects: obligatory object marking, the appearance of the conjoint form with object marking, the absence of any phonological phrase boundary indicators with a doubled object and fixed word order in the context of object marking. These diagnostics can be extended to Bantu languages with local doubling in general.

There is another important influence on co-occurrence, this is the syntactic environment or clause type. *Wh*-questions, clefts, and relative clauses have co-occurrence restrictions which differ from those in affirmative matrix clauses. These are not uniform across the Bantu language family, and are not always predictable based on the behaviour in affirmative matrix clauses. I discuss these in detail in chapter 6.

### 3.3.3 Against the right-dislocation analysis for Haya

Haya has been argued not to allow doubling. Object-marked objects are argued to always be right-dislocated (Byarushengo et al. 1976; Duranti and Byarushengo 1977; Tenenbaum 1977). The key evidence for this is the tone pattern in In (53). In (53a), there is no object marking and only the last object has a falling tone, whereas in (53b), both objects are object-marked and both the verb and each noun phrase following it display a phrase-final tone pattern.

- (53) a. Abakázi ni- ba- bal- íl- a ómwána émbûzi.  
 2woman PROG- SM2- count- APPL- FV 1child 10goat  
 ‘The women count the goats for the child.’ [Haya, Hyman 1999:155]
- b. Abakázi ni- ba- zi- mu- bal- íl- a ómwána émbûzi.  
 2woman PROG- SM2- OM10- OM1- count- APPL- FV 1child 10goat  
 ‘The women count the goats for the child.’ [Haya, Hyman 1999:155]

The morphological evidence is the conjoint/disjoint distinction for the Past 1. Without the object marker, the conjoint form is used, as in (54a), while with object marking the disjoint form is used, as in (54b).

- (54) a. Y- a- kom- a Káto. (conjoint)  
 SM1- PAST1.CJ- tie- FV Kato  
 ‘He tied Kato.’ [Haya, Hyman 1999:160]
- b. Y- áá- mu- kôm- a. (disjoint)  
 SM1- PAST1.DJ- OM1- tie- FV  
 ‘He tied him.’ [Haya, Hyman 1999:160]

Apart these types of evidence, none of the characteristics of local doubling as established above are found in Haya.

Since the analyses discussed for Chichewa, Zulu and Haya above are within different theoretical frameworks and do not overlap completely, I suggest a list of properties associated with right-dislocated constituents for Bantu. Somewhat different definitions are proposed by Averintseva-Klisch (2008) and, for Romance languages, Samek-Lodovici (2006) and Cecchetto (1999).

- A **right-dislocated phrase** is a nominal phrase in clause-final position (following all of the core sentence components, including tense and location and any adverbial modifiers expressing these).
- A **right-dislocated phrase** is co-indexed with a pronominal<sup>23</sup> element inside the clause.
- A **right-dislocated phrase** has an afterthought reading (a kind of repair strategy disambiguating an underspecified reference).
- A **right-dislocated phrase** is phrased separately phonologically.

There are at least two possible attachment sites for right-dislocated elements which would correspond to this definition.

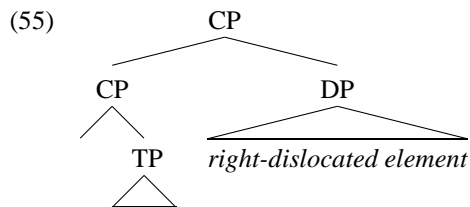

This structure puts a right-dislocated element outside of the scope of negation, whereas the second approach would allow the dislocated element to be within the scope of negation (where negation is above TP) (Buell 2008), such a structure is shown in (56).

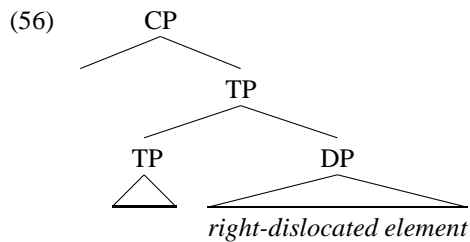

Cross-linguistically, in terms of word order we find that right-dislocated elements follow temporal adverbials. For example in German right-dislocation, a right-dislocated constituent, such as the proper name *Marie* in (57a), follows the temporal adverbial *gestern* and the sentence-final participle. This is different from non-right-dislocated objects, as shown in (57b). German word order differs from Haya, insofar as that the object can appear before or after the temporal adverbial, when both precede the sentence-final participle. However, when the object is right-dislocated, as shown in (57c), this order is rather marked, and the temporal adverbial in this case always has an afterthought reading.

<sup>23</sup>By using the word “pronominal” here I am referring not the status of the element as a pronoun as opposed to an agreement marker but to the way an agreement marker, pronominal clitic, or incorporated or free pronoun can replace a lexical NP inside the sentence in terms of  $\phi$ -features.

- (57) a. Ich habe sie gestern gesehen, die Marie.  
I have.1S she.ACC yesterday see.PRT the.FEM.ACC Mary  
'I saw her yesterday, Mary that is.'
- b. Ich habe Marie gestern gesehen.  
I have.1S Mary yesterday see.PRT  
'I saw Mary yesterday.'
- c. Ich habe sie gesehen, die Marie, gestern.  
I have.1S she.ACC see.PRT the.FEM.ACC Mary yesterday  
'I saw her yesterday, Mary that is.' [German]

If Haya, object-marked “objects” are always right-dislocated we might expect similar restrictions. However, this does not turn out to hold.

Afterthoughts identify a referent. Therefore, entities like proper names or definite nouns with identificational content are expected to be good as afterthoughts, while pronouns and semantically empty nouns are expected to be bad. In the Romance languages, right-dislocation is generally more free and allows a number of different types of phrases, not only DPs, but in all the examples discussed in Samek-Lodovici (2006) the right-dislocated constituent disambiguates a pronoun. To do so, a definite lexical expression which adds new information to identify the proper referent of the pronoun is used. This can be illustrated with data from English. A proper name is acceptable when right-dislocated. This is shown in (58a). A common noun not adding new information such as *person* is judged as degraded, as shown in (58b). Unless a context is imagined where there are non-human referents in the set of discourse entities which could be referred to by *he*. A pronoun is even less acceptable, as shown in (58c), unless it is used deictically (by pointing to one of several possible referents), and becomes even worse when it is a first person singular pronoun, where deictic disambiguation is generally ruled out, as shown in (58d).

- (58) a. I saw him, John, that is.  
b. ?? I saw him, the person that is.  
c. \* I saw him, him that is.  
d. \* He saw me, me that is.

If Haya, object-marked “objects” are right-dislocated elements rather than objects, they should also be semantically restricted. However, again it turns out that this is not the case.

Duranti and Byarushengo (1977) argue that the object marker in Haya is pronominal, because it triggers a special tone pattern when it co-occurs with a lexical object in the right-environment, cannot agree with a relativized object and is optional (Duranti and Byarushengo 1977:47/48). Tenenbaum (1977) tries to provide more evidence in support of this. But none of those papers discuss doubling in much detail. Nor do they attempt to find syntactic data supporting their analysis. According to Tenenbaum (1977:163):

In Haya, a right-dislocation construction is formed *whenever* a noun occurs to the right of the VC [verb cluster, K.R.] and its corresponding

anaphoric pronoun, either a subject marker (SM) or object marker (OM), occurs within the VC.

Duranti and Byarushengo (1977:48) argue that

the DO in sentences such as (13) [with an object marker and a local object, K.R.] *must* be considered a *right-dislocation*

There are potentially three kinds of evidence which support this:

- There is phonological and morphological evidence for dislocation.
- Object marking is not obligatory.
- The word order of two objects is free in all contexts.

There are clear differences between Haya and Smbaa. Haya has no obligatory object marking. Since, as shown below, the order of the two objects in a double object construction is always free, this property cannot be used as a test. In my view, the conjoint/disjoint data from Haya is also hard to evaluate, because the distribution of conjoint/disjoint appears only with one tense where the contrast is marked by vowel length (Hyman 1999), which is also affected by the phonological shape of the subject marker. The boundary tone provides the clearest evidence. However, a syntactic boundary cannot convincingly be established based on only phonological phrasing, since it is well-known that phonological and syntactic phrasing do not always match. Moreover, moving outside of a VP/vP does not necessarily imply right-dislocation. For a number of Bantu languages, including Swahili, Ruwund and Zulu, so-called exclusion principles have been argued for, which force noun phrases with particular features to move out of the vP. These include definite nouns. This kind of approach is argued for in Woolford (2000, 2001) and Buell (2005). In spite of these facts, there is no syntactic or semantic evidence in favour of such an analysis in Haya. In fact, there is evidence that a doubled object in Haya is syntactically local.

The word order of the direct and indirect object in Haya is free, as shown in (59a) and (59b).

- (59) a. N- ka- gulira omwana ekitabo ijo.  
 SM1S- PAST3- buy.APPL 1child 7book day.before.yesterday  
 'I bought the child the book the day before yesterday.'
- b. N- ka- gulira ekitabo omwana ijo.  
 SM1S- PAST3- buy.APPL 7book 1child day.before.yesterday  
 'I bought the book for the child the day before yesterday.' [Haya]

Free ordering only applies to "bare" object nouns. A temporal modifier cannot intervene between a verb and its non-object-marked complements, unless both are object-marked, as shown in (60a). Without object marking this order is completely ungrammatical, as shown in (60b).

- (60) a. N- ka- ki- mu- gulira ijo omwana ekitabo.  
 SM1S- PAST3- OM7- OM1- buy.APPL day.before.y'day 1child 7book  
 'I bought it for him the day before yesterday, the child, the book.'
- b. \* N- ka- gulira ijo omwana ekitabo.  
 SM1S- PAST3- buy.APPL day.before.y'day 1child 7book  
 Int: 'I bought the child the book the day before yesterday.' [Haya]

However, even with object marking there is a preference for the object-marked indirect object to appear immediately after the verb, as shown in (61a) while the construction where the indirect object comes last is judged as degraded, as shown in (61b).

- (61) a. N- ka- ki- mu- gulira omwana ijo ekitabo.  
 SM1S- PAST3- OM7- OM1- buy.APPL 1child day.before.y'day 7book  
 'I bought it for him the day before yesterday, the book, the child.'
- b. ?N- ka- ki- mu- gulira ijo ekitabo omwana.  
 SM1S- PAST3- OM7- OM1- buy.APPL day.before.y'day 7book 1child  
 'I bought it for him the day before yesterday, the book, the child.' [Haya]

If an object-marked object was right-dislocated to a clause-final position it should follow a temporal adjunct in a simple clause. But this is not the case. The unmarked order for an object-marked object and an adjunct, as shown in (62a), is the same as that for a non-object-marked adjunct, as shown in (62b).

- (62) a. Y- aa- mu- bona Kato kileki.  
 SM1- PAST1.DJ- OM1- see 1Kato today  
 'He saw Kato today.'
- b. Y- a- bona Kato kileki.  
 SM1- PAST1.CJ- see 1Kato today  
 'He saw Kato today.' [Haya]

This is not due to dialectal variation between the variety of Haya discussed in the literature, (Byarushengo et al. 1976; Duranti and Byarushengo 1977; Hyman 1999; Tenenbaum 1977), which is based (primarily) on the judgements of Ernest Byarushengo, because Byarushengo et al. (1976) state that "*today* can occur before a non-asserted [right-dislocated, K.R.] object, but only if both are non-asserted" (Byarushengo et al. 1976:200), which implies that the preferred order is the same as the order in (62b).

According to Tenenbaum (1977), an object-marked object cannot precede a non-object-marked object in Haya, as shown in (63a). In this example, the percentage sign before the object indicates a pause, following Tenenbaum's annotation. My Haya data differs from Tenenbaum's, as shown in (63b). In fact, the order IO DO with object marking for a human indirect object is frequently produced spontaneously (for example as the first translation to an English sentence with two objects), and judged as grammatical. According to Samek-Lodovici (2006), right-dislocated constituents in Italian differ from other constituents on the right, by not appearing in the canonical word order (which is different in Italian from Bantu in that the indirect object comes last).

- (63) a. \*Ba- ka- mu- cumbila % Kakulu enkokoko.  
 SM2- PAST3- OM1- cook.APPL 1Kakulu 9chicken  
 Int: 'They cooked it for Kakulu the chicken.'  
 [Haya, Tenenbaum 1977:163]
- b. Ba- ka- mu- cumbila Kakulu enkokoko.  
 SM2- PAST3- OM1- cook.APPL 1Kakulu 9chicken  
 'They cooked the chicken for Kakulu.' [Haya, my data]

The kinds of semantic and pragmatic restrictions illustrated above with the example of English do not apply to object marking in Haya. First person singular pronouns can co-occur with object marking, and precede a temporal adjunct. This is shown for the first person singular pronoun in (64a). A free first or second person pronoun can appear without an object marking in Haya, as shown in (64b). The only difference between this sentence and (64c), where only an object marker expresses the pronoun, is that the sentences with the free pronoun receive a contrastive reading.

- (64) a. A- ka- m- bona inye ijo.  
 SM1- PAST3- OM1S- see me day.before.yesterday  
 'He saw ME the day before yesterday.'
- b. A- ka- bona inye ijo.  
 SM1- PAST3- see me day.before.yesterday  
 'He saw ME the day before yesterday.'
- c. A- ka- m- bona ijo.  
 SM1- PAST3- OM1S- see day.before.yesterday  
 'He saw me the day before yesterday.' [Haya]

In Haya, a noun which adds no new content when following the class 2 object marker such as *abantu* 'people' can also be doubled, as shown in (65a). *Abantu* adds no extra meaning after *-ba-* because generally all nouns in class 2 in Haya are plural humans. When such a noun is the indirect object in a double object construction, it can be followed by the direct object, as shown in (65b).

- (65) a. A- ka- ba- bona abantu ijo.  
 SM1- PAST3- OM2- see 2person day.before.yesterday  
 'He saw the people the day before yesterday.'
- b. N- ka- ba- ha abantu ebitabo.  
 SM1S- PAST3- OM2- give 2people 8books  
 'I gave the people books.' [Haya]

Again, Haya patterns differently from the English data introduced above. For Haya, neither the semantics nor the word order properties support a right-dislocation analysis.

Additional clear evidence against the right-dislocation analysis comes from *wh*-questions. An object-marked object can precede a non-object-marked (human) *wh*-object or adjunct. In Haya, *wh*-objects can never be object-marked and tend to appear

in the IAV (Immediate After Verb) position, as in (66a). However, apart from this unmarked order, another object can also intervene between the verb and the *wh*-element and such an object can be object-marked, as shown in (66b). A *wh*-element is always focal, while cross-linguistically right-dislocated elements appear in postfocal position (Samek-Lodovici 2006). Yet in Haya both orders of the *wh*-element and the object-marked objects are grammatical, as shown in (66).

- (66) a. O- ka- ki- gulira ekitabo owa?  
SM2S- PAST3- OM7- buy.APPL 7book who  
'For who did you buy the book?'
- b. O- ka- ki- gulira owa ekitabo?  
SM2S- PAST3- OM7- buy.APPL who 7book  
'For who did you buy the book?' [Haya]

Lastly, In Haya, sentence-final subjects and objects pattern differently. This is expected if objects are not always right-dislocated. Agreeing subjects in sentence final position are always right-dislocated. Thus if object-marked objects do not have to be right-dislocated, there should be a difference between right-dislocated subjects and local objects. This prediction turns out to hold. Having seen that object-marked objects appear before a temporal modifier in (64a), consider the data in (67). With an unmarked intonation the sentence in (67a), where the temporal modifier follows the subject, is judged as ungrammatical. In contrast, if the subject follows the temporal adverbial the sentence is completely acceptable, as shown in (67b). With a clear pause before *ijo*, grammaticality improves compared to (67a), as shown in (67c). This construction is judged much more marked than (67b).

- (67) a. \*Ba- ka- goba abakazi ijo.  
SM2- PAST3- arrive 2woman day.before.yesterday  
Int: 'They arrived the day before yesterday, the women.'
- b. Ba- ka- goba ijo, abakazi.  
SM2- PAST3- arrive day.before.yesterday 2woman  
'They arrived the day before yesterday, the women.'
- c. Ba- ka- goba abakazi, ijo.  
SM2- PAST3- arrive 2woman day.before.yesterday  
'They arrived, the women, the day before yesterday.' [Haya]

In this section, I have shown that the right-dislocation analysis for Haya is problematic, based on evidence from the meaning of afterthoughts, word order with regard to another complement and with regard to a *wh*-element, and the difference between subjects and objects. The prosodic data and the syntactic facts contradict each other, but since right-dislocation is a syntactic operation, the syntactic evidence against right-dislocation weighs more heavily in my opinion. There are clear differences between languages like Sambia and languages like Haya, but an analysis where object markers are pronouns in one language and agreement markers in the other cannot properly account for those. Local doubling is possible in both, therefore both can be analysed as having object agreement.

### 3.3.4 Conclusions

In this section on doubling of objects with co-referential object markers in Bantu, we have seen a range of different patterns and properties. In the first part, the relevance of doubling for the distinction between pronominal object marking and object agreement in Bantu was introduced. Subsequent sections dealt with the literature on co-occurrence restrictions in Bantu, particularly the seminal paper Bresnan and Mchombo (1987), as well as the evidence for dislocation. It was shown that doubling is possible in languages with multiple object markers. Finally, Haya was discussed in detail with respect to whether object-marked objects are right-dislocated or not. Based on this evidence, the claim that there are Bantu languages with object agreement and Bantu languages with pronominal object markers was rejected. In the final section, I discuss the morphosyntactic differences between those two languages in more detail and compare them to patterns found in other Bantu languages.

## 3.4 Variation in object morphosyntax across Bantu

Not all Bantu languages have object prefixes, the notable exception being the languages of Zone A (Beaudoin-Lietz et al. 2004), and of the large group of Bantu languages that have object prefixes only a small proportion allow multiple object markers (Marten et al. 2007). This group, especially for the Lacustrine languages (including Haya), is generally associated with a particular kind of syntax in the literature, generally being symmetric and having a less agreement-like object marking system. That this association is not necessarily well-founded has been shown in the first sections of this chapter with the example of Sambia and Ruwund. In this section, I will look at a number of ways in which object markers are ordered and interact with the syntax of different Bantu languages. The topics discussed here are the topicality hierarchy, (a)symmetry, and two of the tests presented in Baker (2008) to identify Sambia as an agreement language and Haya as a pronominal object marking language. The final test is discussed in chapter 5. I will show that these paradigms of variation do not map neatly onto such a distinction but might be rather like parametric variation between Bantu languages. The implications of some of these properties for a syntax of agreement will be discussed more in chapter 4.

### 3.4.1 Duranti's topicality hierarchy

Beyond the animacy and definiteness hierarchies discussed above, there is a so-called "thematic hierarchy" which has been proposed for object marking in Bantu. In a number of papers from the late 1970s and early 1980s, Duranti looks at object marking and objects in Bantu (Duranti 1979; Duranti and Byarushengo 1977; Hyman and Duranti 1982). He tests the thematic hierarchies developed in Hyman and Hawkinson (1974) and Morolong and Hyman (1977) on Sambia and Haya, suggesting that these languages are representative of the entire Narrow Bantu group. He suggests that the topicality hierarchy applies to all languages in the family, but that the boundaries be-

tween categories shift between languages, with some categories being collapsed in some languages. These hierarchies, shown in (68), relate to the differential object marking properties observed for languages like Sambia, Swahili, Ruwund, Nyaturu and Makhuwa above.

- (68) a. Person: 1st > 2nd > 3rd  
 b. Thematic Role: Benefactive > Goal > Patient > Instrument/Locative  
 c. Animacy: Human > Animate > Inanimate

Duranti argues that the set of entities which can trigger object marking delimit the set of objects in Bantu. Unlike other object-marked entities, locatives are not always reflected in the argument structure of the verb. There are also obliques which are more argument-like yet cannot trigger object marking. Lastly, there are languages which allow only one object marker but treat their complements in double object constructions symmetrically. It would be highly undesirable to have to treat those as objects or not depending on whether another complement is marked on the verb.

I will discuss how multiple object markers behave and how this relates to asymmetry below, showing that a complex hierarchy may not be necessary. At least in languages like Sambia and Haya, structural relations, such as indirect and direct object can, can account for the possible morpheme orders, and in chapter 5 it will be shown that the Person Case Constraint is sufficient to rule out the ungrammatical combinations.

### 3.4.2 Multiple object markers

It is not clear if there are real restrictions on the number of object markers in Bantu languages which allow more than one object marker (Marten et al. 2007). The exception to this are Nyaturu and Bemba, which only permit a second object marker in a very restricted environment, namely the first person singular nasal can co-occur with other object markers (Hualde 1989). Most languages with multiple object marking allow two or three object markers to co-occur, but more complex forms are rare. Recall that Beaudoin-Lietz et al. (2004) give an example of six object markers from Kinyarwanda, repeated in (69).

- (69) Umugoré a- ra- na- ha- ki- zi- ba- ku- n-  
 1woman SM1- FOC- ALSO- OM.LOC- OM7- OM10- OM2- OM2S- OM1S-  
 someesheesherereza.  
 read.CAUS.CAUS.APPL.APPL  
 ‘The woman is also making us read it (book) with them (glasses) to you for  
 me there (in the house).’ [Kinyarwanda, Beaudoin-Lietz et al. 2004:183]

There is no clear upper limit on the number of object markers allowed in a verb in Sambia,<sup>24</sup> but the acceptability of a sentence deteriorates with increasingly high

<sup>24</sup>Duranti (1979:34) claims that Sambia allows only two object markers while Haya allows more than that. With my informants I found three object markers, where one of them refers to a locative, to be completely acceptable.

numbers of objects. It is robustly grammatical to have three object markers on one verb, as shown in (70). Bantu languages allow multiple applicatives and causatives, so it is possible for a verb to have more than two DP complements. Notably, though, in (70) the class 16 locative object-marked by *-ha-* is not an argument of the verb. It is generally possible to object-mark locatives in Sambia. But no other adjuncts can be object-marked.

- (70) N-    za-        ha-    chi-  m-   nka Stella kitabu.  
 SM1S- PERF.DJ- OM16- OM7- OM1- give 1Stella 7book  
 ‘I gave Stella a book there.’ [Sambia]

For constructions where a verb takes two or more object markers, there is one main restriction: the order of object markers is fixed, as shown in (71). This order applies across Bantu, in spite of all the variation found in object marking patterns across Bantu. This order appears to be strictly adhered to by almost all Bantu languages, with the exception of Kinyarwanda (Kimenyi 1978), where the order is not quite free, as shown below, Tswana and Kwanyama (Marten and Kula 2008).

- (71) subject marker - TAM - locative object marker - direct object - indirect object  
 - verb stem

The ordering of object markers directly mirrors the linear order of lexical indirect objects, direct objects and locatives. The indirect object must be closest to the verb stem, as shown in (72a). If the order is reversed, as in (72b), ungrammaticality results.

- (72) a. N-    za-        chi-  m-   nka Stella kitabu.  
 SM1S- PERF.DJ- OM7- OM1- give 1Stella 7book  
 ‘I gave Stella a book.’  
 b. \* N-    za-        m-    chi-  nka Stella kitabu.  
 SM1S- PERF.DJ- OM1- OM7- give 1Stella 7book  
 Int: ‘I gave Stella a book.’ [Sambia]

The ordering of the object markers is the same in Haya, as shown in (73), the object marker closest to the stem *-ba-* marks the indirect object. The indirect object is plural while the direct object is singular. This does not affect the order. However, person does restrict it. This will be discussed in chapter 5.

- (73) Tu-   lika- gi-   mu-  ba-  chumbilila-    mu.  
 SM2P- RMF- OM9- OM1- OM2- cook.APPL.APPL- OM18  
 ‘We will (in the far remote future) cook him in it on their behalf.’  
 [Haya, Rubanza 1988:117]

Bearth (2003:126) suggests that, across Bantu, the mirroring of the order of lexical object DPs by the order of the prestem object marker cuts across all syntactic types of object marking and is non-accidental. However, Marten and Kula (2008) cite data from Chaga where instrumentals and locatives fit somewhat less neatly into this system. Moreover, Tswana can reverse the order of the object markers for the direct and the indirect object in a double object construction. This is shown for the order also found in other Bantu languages in (74a) and for the reversed order in (74b).

- (74) a. Ke e mo apeetse.  
SM1 OM9 OM1 cook.APPL.PERF  
'I cooked him/her it.'  
[Tswana, Marten and Kula 2008, their example (54)]
- b. Ke mo e apeetse.  
SM1 OM1 OM9 cook.APPL.PERF  
'I cooked him/her it.'  
[Tswana, Marten and Kula 2008, their example (53)]

Kinyarwanda, according to Kimenyi (1978), allows the locative marker and the reflexive, but no other object markers, to appear in different positions. The locative object marking can either follow the direct object (and therefore appear closest to the stem), as in (75a), or precede it (75b), as it would have to in languages like Sambia.

- (75) a. Ba- ra- kí- há- shyira.  
SM2- PRES- OM7- OM16- put  
'They put it there.' [Kinyarwanda, Kimenyi 1978:182]
- b. Ba- ra- há- kí- shyira.  
SM2- PRES- OM16- OM7- put  
'They put it there.' [Kinyarwanda, Kimenyi 1978:182]

In Kinyarwanda, reversing the order of the object markers is not possible with first person, as shown in (76a). In this case, only the order where the first person object marker is closest to the stem is allowed, as shown in (76b).

- (76) a. \* Y- a- m- ha- gi- ir- iye.  
SM1- PAST- OM1S- OM16- go BEN- ASP  
Int: 'He went there for me.' [Kinyarwanda, Kimenyi 1978:183]
- b. Y- a- ha- n- gi- ir- iye.  
SM1- PAST- OM16- OM1S- go BEN- ASP  
'He went there for me.' [Kinyarwanda, Kimenyi 1978:183]

Reversing the order of the object markers is also ungrammatical with the reflexive, as shown in (77a), with the grammatical order shown in (77b).

- (77) a. \* A- r- íí- há- kor- a.  
SM1- PRES- REFL- OM16- touch- ASP  
Int: 'He touches himself there.' [Kinyarwanda, Kimenyi 1978:183]
- b. A- rá- h- íí- kor- a.  
SM1- PRES- OM16- REFL- touch- ASP  
'He touches himself there.' [Kinyarwanda, Kimenyi 1978:183]

However, it is grammatical for the locative marker to be closest to the verb stem with the second person singular object marker, as shown in (78).

- (78) Y- a- ku- ha- gi- ir- iye  
SM1- PAST- OM2S- OM16- go BEN- ASP  
'He went there for you.' [Kinyarwanda, Kimenyi 1978:183]

The strict ordering of object markers applies to the vast majority of Bantu languages but is not quite universal. The special status which the first and/or second person singular object marker and the reflexive morpheme have in Bantu and cross-linguistically is discussed in chapter 5. A second restriction on multiple object marking in Sambiaa is related to asymmetry. Unlike for morpheme orders there is a lot of variation across Bantu for the so-called accessibility of an object for object marking. This is discussed in the next subsection.

### 3.4.3 Asymmetry

Many of the tests discussed in this chapter apply to constructions with more than one object. There is an on-going debate as to whether (particular) Bantu languages have double object constructions (Schadeberg 1995; Thwala 2006) or simply one complement and the ability to add more through morphosyntactic means using valency increasing morphemes such as the applicative or causative, as argued in Thwala (2006).

In the Bantu literature, a distinction is generally made between the so-called primary object and others. The primary object, which corresponds to what is referred to here as the indirect object, is one which allows object marking, can be passivized and has access to the position immediately after the verb (Schadeberg 1995). More widely a distinction is made between languages with asymmetric double object constructions and languages with symmetric double object constructions (Bresnan and Moshi 1990; Marten et al. 2007; Rugemalira 1991). This is also based on the behaviour of the direct and indirect object in double object constructions with regard to access to the immediately postverbal position, the ability to trigger object marking on the verb, and the ability to be passivized. Based on these criteria, Swahili and Chichewa are asymmetric, while Haya and Rundi are symmetric. Across the Bantu family, it has been observed that the languages which allow more than one object marker, such as Haya and Rundi, tend to be symmetric. Baker (2008) suggests that this is a consequence of the properties of syntactic agreement as opposed to object clitics. Bentley (1994) also lumps together agreement, animacy-sensitivity, having only one object marker and asymmetry as related properties. However, although this may well be a tendency across Bantu, these three properties do not correlate systematically with one another. For example, Sambiaa is an asymmetric language with multiple object markers. Chichewa is asymmetric but has no animacy effects. For the languages discussed here, though, it is the case that all the languages that have animacy effects are asymmetric.

The distinction between symmetric and asymmetric languages has been criticised because usually some but not all of these criteria apply to particular languages. In this section I will discuss the three most commonly discussed differences between symmetric and asymmetric languages for Sambiaa, Swahili and Haya, in turn.

**Sambiaa** Sambiaa is asymmetric. As (79) shows, object marking the direct object is ungrammatical if the indirect object is not also object-marked. Even if the lexical direct object is dropped, the construction remains ungrammatical.

- (79) \* N- za- chi- nka Stella (kitabu).  
 SM1S- PERF.DJ- OM7- give 1Stella 7book  
 Int: 'I gave Stella a book.' [Sambaa]

In double object constructions, the indirect object can be passivized, as shown in (80a). In general, Sambaa does not allow passivization of the direct object in double object constructions, even with a free pronoun expressing the indirect object, as shown in (80b). Adding an object marker for the pronoun does not improve the grammaticality of the construction, as shown in (80c). Object marking in the passive is discussed in section 3.4.4.

- (80) a. Ni- za- inkwa kitabu.  
 SM1S- PERF.DJ- give.PASS 7book  
 'I was given a book.'
- b. \* Kitabu chi- za- inkwa imi.  
 7book SM7- PERF.DJ- give.PASS me  
 Int: 'The book was given to me.'
- c. \* Kitabu chi- za- ni- inkwa (imi).  
 7book SM7- PERF.DJ- OM1S- give.PASS me  
 Int: 'The book was given to me.' [Sambaa]

The asymmetry of the passive can occasionally be violated, by some speakers, as shown in (81a).<sup>25</sup> The preferred form is (81b), which is a monotransitive verb followed by an adjunct clause.

- (81) a. Vitabu vi- ghuliwe wana.  
 8book SM8- buy.APPL.PASS.PERF.CJ 2child  
 'The books were bought (for) the children.'
- b. Vitabu vi- za- ghulwa kwa mbui ya wana.  
 8book SM8- PERF.DJ buy.PASS 17ASSOC 9matter 9ASSOC 2child  
 'The books were bought on behalf of the children.' [Sambaa]

Sambaa has a strict order of the indirect and direct object, where the indirect object immediately follows the verb, as shown in (82).

- (82) Subject Verb Indirect-Object Direct-Object (Adjunct)

This is illustrated in (83a). The reverse order is ungrammatical, as shown in (83b).

- (83) a. N- za- m- nka Stella kitabu.  
 SM1S- PERF.DJ- OM1- give 1Stella 7book  
 'I gave Stella a book.'
- b. \* N- za- m- nka kitabu Stella.  
 SM1S- PERF.DJ- OM1- give 7book 1Stella  
 Int: 'I gave a book (to) Stella.' [Sambaa]

<sup>25</sup>But even those speakers who sometimes accepted this construction did not *generally* find it grammatical.

The relative ordering of the complements in double object constructions in Smbaa is not affected by the presence of object marking, as shown in (84). The indirect object must immediately follow the verb, even if it agrees with the verb.

- (84) a. \* N-      za-      (m)- nka kitabu Stella.  
           SM1S- PERF.DJ- OM1- give 7book 1Stella  
           Int: ‘I gave Stella a book.’ [Smbaa]

As shown by the word order restrictions, object marking patterns and passivization facts in this section, Smbaa is clearly asymmetric. However, the data in (83) and (84) shows that Smbaa is different from other asymmetric Bantu languages like Chichewa and Swahili. For Chichewa, it has been argued that free word order is “licensed” by agreement morphology (Mchombo 2004). In Swahili and Smbaa, the order of the direct and indirect object is not affected by object marking. In Swahili the order of the direct and indirect object is free and in Smbaa the order is fixed.

**Swahili** Swahili allows only one object marker. For Swahili, which is also asymmetric, only two of the three properties of asymmetric languages hold. Only the indirect object can be marked, as shown in (85a); object marking the direct object in a double object construction is ungrammatical as shown in (85b), regardless of whether the direct object is overt or not.

- (85) a. A-    li-    m-    nunulia Juma kitabu.  
           SM1- PAST- OM1- buy.APPL 1Juma 7book  
           ‘She bought a book for Juma.’  
       b. \* A-    li-    ki-    nunulia Juma (kitabu).  
           SM1- PAST- OM7- buy.APPL 1Juma 7book  
           Int: ‘She bought a book for Juma.’ [Swahili]

A direct object cannot be passivized in a double object construction, as shown in (86b). This shows that Swahili is asymmetric for the first two properties.

- (86) a. Juma a-    li-    nunuliwa kitabu.  
           1Juma SM1- PAST- buy.APPL 7book  
           ‘Juma was bought a book.’  
       b. \* Kitabu ki-    li-    nunuliwa Juma.  
           7book SM7- PAST- buy.APPL 1Juma  
           Int: ‘A book was bought Juma.’ [Swahili]

The order of the indirect and direct object is free in Swahili, as shown in (87). Marten et al. (2007) claim that this is ungrammatical. Bentley (1994) argues that the word order properties are determined by the animacy of the two complement noun phrases. However, in my data both orders are found. Ngonyani (1996) also has examples of both orders.

- (87) a. A-    li-    m-    nunulia Juma kitabu.  
           SM1- PAST- OM1- buy.APPL 1Juma 7book  
           ‘She bought a book for Juma.’

- b. A- li- m- nunulia kitabu Juma.  
SM1- PAST- OM1- buy.APPL 7book 1Juma  
'She bought a book for Juma.'  
[Swahili]

**Haya** Haya is a symmetric language. Either object can trigger object marking, as shown for the indirect object in (88a) and for the direct object in (88b).

- (88) a. A- ka- mú- cumb- il' ébitooke.  
SM1- PAST3- OM1- cook- APPL 8bananas  
'He cooked bananas for him.'
- b. A- ka- bí- cumb- il' ómwáana.  
SM1- PAST3- OM8- cook- APPL 1child  
'He cooked them for the child.'  
[Haya]

Either object can be passivized, as shown for the indirect object in (89a) and for the direct object in (89b).<sup>26</sup>

- (89) a. Kato a- shaziirwe enyama na John.  
1Kato SM1- cut.APPL.PASS.PAST 9meat by 1John  
'Kato was cut meat by John.'
- b. Enyama e- shaziirwe Kato na John.  
9meat SM9- cut.APPL.PASS.PAST 1Kato by 1John  
'The meat was cut for Kato by John.'  
[Haya]

The relative order of the direct object and indirect object is free, as illustrated in (90).

- (90) a. N- ka- gulira omwana ebitooke.  
SM1S- PAST3- buy.APPL 1child 8banana  
'I bought the child food.'
- b. N- ka- gulira ebitooke omwana.  
SM1S- PAST3- buy.APPL 8banana 1child  
'I bought food for the child.'  
[Haya]

Haya and Sambia are clear examples of symmetric and asymmetric languages, respectively, while Swahili is more hybrid, showing features of both types. However, Chichewa is asymmetric without having obligatory marking. This is shown for object marking in (91a) and (91b).

- (91) a. Mavuto a- na- wa- umbira mtsuko (ana).  
Mavuto SM1- PAST- OM2- mold.APPL 3waterpot 2child  
'Mavuto molded the waterpot for them (the children).'  
[Chichewa, Baker 1988b:355]

<sup>26</sup>This might not hold for all dialects of the language.

- b. \* Mavuto a- na- u- umbira ana (mtsuko).  
 Mavuto SM1- PAST- OM3- mold.APPL 2child 3waterpot  
 ‘Mavuto molded it (the waterpot) for the children.’

[Chichewa, Baker 1988b:355]

The word order of the two complements cannot be reversed, as shown in (92a), for the grammatical order, and (92b), for the ungrammatical order.

- (92) a. Anyani a- ku- pangira atsikana mauta.  
 2baboon SM1- PRES- make.APPL 2girl 3bow  
 ‘The baboons are making bows for the girls.’

[Chichewa, Baker 1988b:370]

- b. \* Anyani a- ku- pangira mauta atsikana.  
 2baboon SM1- PRES- make.APPL 3bow 2girl  
 Int: ‘The baboons are making bows for the girls.’

[Chichewa, Baker 1988b:370]

Again, for the passive, Chichewa is asymmetric. As shown in (93a), the indirect object can be passivized, while the direct object cannot, as (93b) shows.

- (93) a. Ana a- na- phikiridwa nsima.  
 2child SM2- PAST- cook.APPL.PASS cornmush  
 ‘The children were cooked cornmush.’

[Chichewa, Baker 1988b:386]

- b. \* Nsima i- na- phikiridwa ana.  
 cornmush SM- PAST- cook.APPL.PASS 2child  
 Int: ‘The children were cooked cornmush.’

[Chichewa, Baker 1988b:386]

Chichewa does not have obligatory object marking and does not allow doubling of the object marker with a local object. This shows that there is no predictable correlation between asymmetry and object agreement.

**The effects of animacy and asymmetry on Sambia object marking** For languages like Sambia, the accessibility hierarchy in multiple object construction can be schematized as in (94). An indirect object must be object-marked in order for the direct object to be object-marked in a double object construction. This means that there are three grammatical patterns: no object marking (if the indirect object does not require object marking for the semantic reasons illustrated in section 3.2), object marking for the indirect object only, or object marking for both objects.

- (94) indirect object > direct object > oblique

Recall that with a proper name, such as *Stella* in sentences like (3) on page 44, object marking is obligatory. However, the ungrammaticality of the V DO IO word order does not improve with an indirect object which does not trigger obligatory agreement,

as shown in (95a). The indirect object can be object-marked without marking the direct object, as shown in (95b) but the direct object cannot be object-marked without marking the indirect objects as shown in (95c). As expected, object marking both objects is grammatical, as shown in (95d).

- (95) a. \* N-    za-           ghuliya   kitabū ng'wana.  
           SM1S- PERF.DJ- buy.APPL 7book 1child  
           Int: 'I bought a/the child a/the book.'
- b. N-    za-           m-    ghuliya   ng'wana kitabū.  
           SM1S- PERF.DJ- OM1- buy.APPL 1child 7book  
           'I bought the child the book.'
- c. \* N-    za-           chi- ghuliya   ng'wana kitabū.  
           SM1S- PERF.DJ- OM7- buy.APPL 1child 7book  
           Int: 'I bought the child the book.'
- d. N-    za-           chi- m-    ghuliya   ng'wana kitabū.  
           SM1S- PERF.DJ- OM7 OM1- buy.APPL 1child 7book  
           'I bought the child the book.' [Sambaa]

The semantic role is the determining factor here, as shown in (96a). Although *Sauda* is a proper name and would require object marking in a simple transitive clause, it cannot be object-marked in (96a) where the indirect object is not object-marked. The indirect object *wavyazi wake* 'his parents', which is a kind of noun phrase that does not trigger obligatory object marking, can be object-marked without object marking the direct object, as shown in (96b). Finally, both objects can be marked, as shown in (96c). Again, the indirect object is marked closest to the verb stem.

- (96) a. \* Juma a-    za-           m-    tambulishiza   wavyazi wakwe Sauda.  
           1Juma SM1- PERF.DJ- OM1- introduce.CAUS 2parent 2his 1Sauda  
           Int: 'Juma introduced Sauda to his parents.'<sup>27</sup>
- b. Juma a-    za-           wa-    tambulishiza   wavyazi wakwe Sauda.  
           1Juma SM1- PERF.DJ- OM2- introduce.CAUS 2parent 2his 1Sauda  
           'Juma introduced Sauda to his parents.'
- c. Juma a-    za-           m-    wa-    tambulishiza   wavyazi wakwe Sauda.  
           1Juma SM1- PERF.DJ- OM1- OM2- introduce.CAUS 2parent 2his 1S.  
           'Juma introduced Sauda to his parents.' [Sambaa]

Note that the applicative verb in (95) and the causative verb in (96) have the same word order and agreement properties.

According to Bentley (1994) animacy-sensitive languages generally have only one object marker slot. This does not hold for Sambaa, as many examples discussed here, including (96b) show, or for Ruwund.

<sup>27</sup>It is not entirely clear whether *-iz-* here should be analysed as a causative or an applicative, as in this context both would have the same morphological form. *Kutambulisha* 'to introduce' is the causative form of the verb *kutambua* 'to recognise', and is a simple transitive not ditransitive verb. Based on the meaning of the verb in this context the causative seems to be more appropriate here.

The facts discussed in this section reveal that freedom of word order and the ability of any object to trigger object marking differ are connected. Yet the order of the object marker prefixes seems to correspond to the underlying word order which is the same for most Bantu languages. The implications of the Sambia pattern on the syntax of agreement will be discussed in chapter 4. The next section discusses Baker's criteria for object agreement.

#### 3.4.4 Baker (2008) on Sambia and Haya

In Baker (2008), there is a brief discussion, mostly in footnotes, of object marking in Sambia and Haya. In this discussion, three properties are tentatively suggested as tests for the agreement/pronoun distinction. The three properties are: object marking in the passive, object marking with reflexives and Person Case Constraint violations. All the data and description of Sambia and Haya in Baker's book are taken from Duranti (1979). My data differs from Duranti's for several of the relevant properties. Rubanza's (1988) analysis of Haya also differs from Duranti's for some relevant aspects. However, based on Duranti's data, which shows a consistent pattern for the three properties, Baker (2008) argues that Sambia has syntactic agreement while Haya has pronominal clitics. In this section, I contrast the data reported in Baker (2008) with my own data for the two languages and discuss two of his tests: the passive and the reflexive. The third test is addressed in chapter 5.

Sambia allows several object markers to appear on a verb. Theories of agreement such as Baker (2008) propose that "true" agreement is restricted to a single object. He makes specific claims about Sambia with regard to this analysis. The main restriction is that if a language allows agreement with more than one complement the second one will not show person agreement. This is based on data related to the Person Case Constraint. However, as will be shown in this section, this is not the case for languages like Sambia.

**Passive** Baker proposes the passive as a diagnostic for "real" agreement. The argument behind this is that if object marking morphology can appear on a verb in the passive voice then it is not an agreement marker but a moved object clitic. Baker bases this test on Burzio's generalization (Baker 2008:98, fn. 25), treating object marking on par with accusative case. In Sambia, object marking the direct object after the indirect object has been passivized is grammatical, as shown in (97).

- (97) N-    za-       chi- nkwa    n' tate.  
       SM1S- PERF.DJ- OM7- give.pass by 1father.my  
       'I was given it by my father.' [Sambia]

According to Baker's criteria, this would indicate that Sambia is not a language with object agreement. However, Baker, based on the data from Duranti (1979), claims that Sambia does not allow object marking in the passive and thus comes to the opposite conclusion.

Sambaa allows more than one object marker in the passive as shown in (98) where a locative object marker appears along with the class 5 marker *-ji-*. The object-marked object can double a local object just like in an active clause. The second complement *kui* ‘dog’ can only be interpreted as the theme, not as the beneficiary.

- (98) Ng’ombe zi-    za-        ha-    ji-    onyeshwa kui.  
 10cow    SM10- PERF.DJ- OM16- OM5- show.PASS 5dog  
 ‘The cows were shown a/the dog there.’ [Sambaa]

To express a beneficiary object (other than the argument raised to subject position) a preposition must be used, such as *kwa* ‘to’ in (99b). In Sambaa, the difference in the argument structure is not reflected in the verbal morphology, as the contrast between (99a) and (99b) shows. The object marker in (99c) is grammatical, but the only possible interpretation is that ‘dog’ is the direct object, not the goal. In (99d) the counterpart to (99b) is shown. Here object marking is ungrammatical. However, this is a general property of *kwa* and other prepositional phrases in Sambaa.

- (99) a. Ng’ombe zi-    za-        onyeshwa kui.  
 10cow    SM10- PERF.DJ- show.PASS 5dog  
 ‘The cows were shown a/the dog.’  
 b. Ng’ombe zi-    za-        onyeshwa kwa kui.  
 10cow    SM10- PERF.DJ- show.PASS 17ass 5dog  
 ‘The cows were shown to the dog.’  
 c. Ng’ombe zi-    za-        ji-    onyeshwa kui.  
 10cow    SM10- PERF.DJ- OM5- show.PASS 5dog  
 ‘The cows were shown a/the dog.’  
 \* ‘The cows were shown to the dog.’  
 d. \* Ng’ombe zi-    za-        ji-    onyeshwa kwa kui.  
 10cow    SM10- PERF.DJ- OM5- show.PASS 17ass 5dog  
 Int: ‘The cows were shown to the dog.’ [Sambaa]

According to Rubanza (1988), Haya does not allow object marking in the passive either. However, the Bugabo dialect of Haya does allow object marking in the passive form, as shown in (100b).

- (100) a. N-    ka-    ebwa    ekitabo.  
 SM1S- PAST3- give.PASS 7book  
 ‘I was given a/the book.’  
 b. N-    ka-    ki-    ebwa.  
 SM1S- PAST3- OM7- give.PASS  
 ‘I was given it.’ [Haya]

Recall that Haya *by*-phrases are normally introduced with a preposition, as in (89) above. However, Haya allows the agent in a passive construction to appear as a bare noun in some contexts, as shown in (101).

- (101) Omuhýó gw- a- shazibwa kat' ényama.  
 3knife SM3- PAST1- cut.with.PASS Kato 9meat  
 'The knife was used to cut the meat by Kato.'

[Haya, Duranti and Byarushengo 1977:53]

This is ungrammatical in Smbaa. This indicates that, just as in active clauses, there are some differences between Haya and Smbaa syntax. However, as far as object marking is concerned, the two languages pattern alike.

In Swahili, it is generally not possible to have object marking with passive verbs, as shown in (102a), irrespective of whether the object *kitabu* is expressed or not (see also Bearth (2003:136)). The grammatical counterpart is shown in (102b).<sup>28</sup>

- (102) a. \* Ni- li- ki- letewa (kitabu).  
 SM1S- PAST- OM7- bring.PASS 7book  
 'I was brought a book.'

- b. Ni- li- letewa kitabu.  
 SM1S- PAST- bring.PASS 7book  
 'I was brought a book.'

[Swahili]

As argued in Bresnan and Mchombo (1987), Chichewa does not have object agreement, but rather pronominal clitics. According to Mchombo (2004), Chichewa does not allow object marking in the passive, as shown in (103). However, the sentence in (103) does not prove this. The passive is not of a ditransitive verb but a simple transitive. It is not to be expected in any language that the object which undergoes raising to subject position, and agrees as a subject, would also be object-marked. As in Haya or Smbaa, one would expect the other object in a double object construction to be the one which could be object-marked if the language allows object marking in the passive. However, if Mchombo's claim about object marking in the passive holds in general, Baker's distinction fails to make the right prediction for languages like Chichewa as well.

- (103) \* Maúngu a- ku- wa- phikidwa (ndí kálulu).  
 6pumpkin SM6- PRES- OM6- cook.PASS by 1a.hare  
 'The pumpkins are being cooked (by the hare)'

[Chichewa, Mchombo 2004:91]

<sup>28</sup>There are exceptions to this with verbs which have passive morphology but no passive semantics. One such verb is *-elewa* 'understand' from *-elea* 'be clear' which can take an object marker, as shown in (1a), that can freely double with a local object (1b). Thanks to Thilo Schadeberg for drawing my attention to this.

- (1) a. N- a- ku- elewa kabisa.  
 SM1S- PRES- OM1- be.clear.PASS completely  
 'I understand you completely.'
- b. N- a- i- elewa hasira ya kundi...  
 SM1S- PRES- OM9- be.clear.PASS 9anger 9ASSOC 5group  
 'I understand the anger of the group...'

[Swahili]

However, Baker, who does not focus on co-occurrence restrictions, cites Mchombo (2004:91) as evidence that Chichewa has object agreement (Baker 2008:196). Based on the languages discussed here, object marking in the passive does not make any distinction between the two types of languages. However, as the data from Sambiaa and Haya show, there are other aspects of the morphosyntax of the passive construction which do differ across Bantu. Moreover, Baker's test is based on Burzio's generalization which relates to case assignment. Bantu languages do not have overt case marking but they would still be analysed as requiring structural case for overt DPs in Generative Syntax.<sup>29</sup> This means that any object noun which is not embedded inside a PP (that could assign case) in a passive clause is problematic for Burzio's generalization. This means Sambiaa, Haya and Swahili all violate Burzio's generalization. This problem has been noted in the syntactic literature on double object constructions, for example in Harley (1995). In fact, McGinnis (2004:51) even points out this problem for Burzio's Generalization using symmetric passive sentences with object marking for the Bantu language Chaga.

To conclude, we can disregard Baker's test for theoretical reasons as well as for the inconsistent results when applied to more Bantu languages.

**Reflexives** According to Baker, languages with "true" agreement do not allow object marking with reflexives. Indeed, with reflexive verbs object marking is ungrammatical in Sambiaa, as shown in (104b). A grammatical reflexive sentence with a direct object is shown in (104a), object-marking this object is ungrammatical, as shown in (104b). A non-reflexive double object construction is grammatical with object marking, as is expected, as shown in (104c).

- (104) a. Ni- ki- ghul- iye kitabu.  
SM1S- REFL- buy- PERF.CJ 7book  
'I bought a book for myself.'
- b. \* Ni- chi- ki- ghul- iye kitabu.  
SM1S- OM7- REFL- buy- PERF.CJ 7book  
Int: 'I bought a book for myself.'
- c. Ni- chi- m- ghul- iye ng'wanangu.  
SM1S- OM7- OM1- buy- PERF.CJ child.POSS.1S  
'I bought a book for my child.'
- [Sambiaa]

The Swahili reflexive morpheme is similar in form to the Sambiaa reflexive morpheme and appears in the same preverbal position, as shown in (105a). Like in Sambiaa, in Swahili object marking with a reflexive is ungrammatical, as shown in (105b), as is expected here since there is only one preverbal slot.<sup>30</sup> As expected, the corresponding construction with two object-marked arguments is ungrammatical, as shown (105c).

<sup>29</sup>Baker (2008:163) actually raises the possibility that noun phrases in Bantu do have case but he does not pursue this possibility further.

<sup>30</sup>The reflexive in Bantu is argued to target the same morphosyntactic position as the object marker, Meeussen (1967), Harjula (2004:127) for Ha.

- (105) a. Ni- li- ji- nunulia kitabu.  
SM1S- PAST- REFL- buy.APPL 7book  
'I bought a book for myself.'
- b. \* Ni- li- ki- ji- nunulia.  
SM1S- PAST- OM7- REFL- buy.APPL  
Int: 'I bought it (book) for myself.'
- c. \* Ni- li- ki- m- nunulia mwanangu.  
SM1S- PAST- OM7- OM1- buy child.POSS.1S  
Int: 'I bought a book for my child.' [Swahili]

In Haya, it is grammatical to have object marking with reflexives, as shown in (106b). The reflexive has a different shape from the *ji/ki* morphemes in Sambia and Swahili. Unlike the reflexive in Kinyarwanda (discussed in section 3.4.2), the Haya reflexive morpheme appears in a fixed position, immediately adjacent to the verb stem. It can appear with more than one object marker, including a benefactive. Duranti and Byarushengo (1977) give an example of a reflexive with an object-marked theme and beneficiary, as shown in (106c). My data and the facts reported in Duranti (1979); Duranti and Byarushengo (1977) match, but according to Rubanza (1988) object markers cannot co-occur with the reflexive morpheme in Haya (Rubanza 1988:182).

- (106) a. N- k- e- gulira ekitabo.  
SM1S- PAST- REFL- buy.APPL 7book  
'I bought a book for myself.'
- b. N- ka- ky- e- gulira.  
SM1S- PAST- OM7- REFL- buy.APPL  
'I bought it (book) for myself.'
- c. Kat' á- ka- ga- b- éé- siigila.  
1Kato SM1- PAST- OM6 OM2- REFL- smear.APPL  
'Kato smeared it on himself for them.'
- [Haya, Duranti and Byarushengo 1977:64]

For agreement with reflexives, Sambia and Swahili and the majority of the Bantu languages differ from Haya and Kinyarwanda. Since passives are grammatical with object agreement in Sambia, this difference for reflexives is unlikely to be due to a case or argument structure related reason.

As shown in the table in (3.2), Sambia and Haya pattern alike for one of the tests for agreement proposed by Baker and differ for the other one. Both languages allow object marking with passives, which would put both languages into the pronominal category for Baker, while only Haya allows object marking with the reflexive. The tests are inconclusive for Sambia. Moreover, in chapter 5, another test that is mentioned in Baker (2008) will be discussed: whether or not a language obeys the Person Case Constraint (PCC). It will be shown that there is no difference between Haya and Sambia for this property. This means that both languages have inconclusive results for Baker's tests. Apart from that, the data in chapter 5 are problematic for Baker's entire theory of Agree because it is shown that languages can Agree in Person with two objects.

Table 3.2: Summary of Baker's tests

Property	Sambaa	Haya	Agreement languages
OM in passive	yes	yes	no
OM in reflexive	no	yes	no

### 3.5 Conclusion

In this chapter, I have looked at a range of morphosyntactic properties related to the syntax of object marking in Bantu. There are a number of differences between languages like Haya and languages like Sambaa. While Sambaa object marking looks like a more clear-cut and prototypical case of agreement than Haya object marking, there is no conclusive evidence for the claim that Haya has pronominal object marking. Crucially, the right dislocation analysis for Haya can be rejected based on the syntactic facts presented here. Object-marked objects do not share the properties established for local objects based on the Sambaa data. However, they do not have the properties that right-dislocated elements have in Haya.

Sambaa and Haya differ in their morphosyntax in several ways. However, the phonological evidence does not map onto systematic syntactic differences, and although the tonal patterns observed in languages like Chichewa and Haya are intriguing, there is no convincing evidence that this is linked to the agreement/pronoun distinction. Moreover, the syntax of the conjoint/disjoint alternation is still poorly understood, especially cross-linguistically.

Sambaa and other languages with obligatory agreement pattern together for a number of criteria, including asymmetry and the way animacy effects work. However, there are also differences amongst these languages in terms of co-occurrence restrictions and flexibility in their syntax. The differences between the groups are not clearly any more profound than the differences within the two groups.

Some properties of object marking are shared by nearly all Bantu languages. Morphologically, Bantu object marking is rather uniform: although Bantu languages differ in terms of flexibility in their word order, the basic word order and the basic morpheme order is the same across the entire family. Moreover, across Bantu the basic order of the object marker prefixes mirrors the order of the lexical objects. If object markers are agreement markers in some languages and pronouns in others, then it is surprising how uniformly they are ordered across the language family.

Contra what is proposed in Baker (2008), syntactic operations like passivation cannot be used to distinguish two types of Bantu languages either.

In the next chapter, I will discuss the implication on the syntax of Bantu of some of those properties, focussing on the way different types of objects are able to trigger object marking, on which types of entities cannot be object-marked across Bantu and how this relates to word order. We will return to the issue of symmetric object marking, which will be shown to be a challenge for Agree theory and turn out to be even more problematic for the pronominal incorporation analysis.



## CHAPTER 4

---

### The syntax of object marking

---

Verbal object agreement is not uncommon cross-linguistically. For example, in a study of 378 languages by Siewierska (2008) the majority have verbal person marking for both agent and patient. Still, having agreement affixes, clitics or weak pronouns to mark a subject is much more common than marking an object in such a way. Moreover, verbal marking for more than one object is rare cross-linguistically (Siewierska 2004:43). As shown in chapter 3, Sambia and Haya are languages of this type. In spite of its widespread occurrence, verbal object agreement has received little attention in Generative syntax, and object agreement is generally not mentioned at all in the literature on Agree. This might be because verbal object marking is absent in the Indo-European languages, and in the East Asian languages that are well-studied. In the Principles and Parameters era, AgrOP was introduced as a landing site for objects in languages such as English which have no overt agreement on the verb. AgrOP was responsible for checking object case and objects were argued to move to Spec, AgrOP to check case either overtly or covertly. In Minimalist syntax, AgrOP has been abandoned again in favour of vP.

In this thesis, I argue that Sambia is a language which has syntactic object agreement. Moreover, it is argued that full object agreement is possible with two objects at the same time, in a ditransitive verb, contra Baker (2008). This chapter illustrates how this fits into Minimalist ideas about agreement. Person agreement with more than one object is a complex syntactic phenomenon, which is discussed in chapter 5. Two other special cases are object marking with *wh*-words and object marking with coordinated noun phrases. These are discussed in chapters 6 and 7.

The implementation of Agree that is proposed in Chomsky (2000), is a complex operation involving a number of additional Principles and conditions: Equidistance, the Defective Intervention Constraint (DIC), and the requirement of both Probe and

Goal to be “active”. This complexity is reduced somewhat in Chomsky (2001), where Equidistance is scrapped.<sup>1</sup>

In this chapter, I show that Smbaa object marking patterns can be derived with a simplified and more Minimalist Agree mechanism. While this theoretically more desirable mechanism can account for Smbaa, there are problems accounting for some of the properties of object marking in Haya and to a lesser extent in Swahili. Swahili requires a rule which rules out Agree with any but the highest complement. But Haya poses a more serious challenge to the theory of Agree. In spite of this, the fact that Smbaa agreement can be derived without Equidistance and the DIC shows that neither condition should be considered as a Principle of Universal Grammar.

The first part of this chapter focusses on agreement in Smbaa. In section 4.1, I introduce Julien’s (2002) view of Bantu verbal morphosyntax and verb movement. In section 4.2, I introduce the mechanism of Agree that was developed in Chomsky (2000) and Chomsky (2001). In section 4.3, I look at specific cases of the application of Agree including subjects, objects, double objects and locatives, before discussing the relationship between agreement and case, and Agree and PPs. Section 4.4 applies the concept of Agree to the object marking patterns found in Haya and Swahili.

In chapter 3, I have argued that object marking in Bantu languages like Haya is not pronominal, based on evidence showing that, when object marking appears, a co-indexed object does not need to be right-dislocated. However, I also showed that there are considerable morphosyntactic differences between object marking in Smbaa and in Haya. In this chapter, the properties of Smbaa object agreement are analysed in a theoretical framework and then compared to those of Haya and Swahili. There are two problematic facts that need to be accounted for: firstly, the fact that object agreement is largely optional in Bantu languages (as shown in chapter 3), and, secondly, the Haya data introduced in section 3.4.3 which show that either object can be object-marked in a double object construction in Haya.

## 4.1 Julien (2002) on Bantu verb syntax

Julien (2002) proposes that morphologically complex words can be formed by two different processes. One of these is syntactic, namely head movement, following Travis (1984) and Kayne (1994), and the other one is phonological. In Julien’s view, phonological word formation is not a morphosyntactic process but the spelling out of independent heads in an arbitrarily-sized phonological chunk. In this system, words are psychological constructs, not morphosyntactic entities. This is reflected by the visible morpheme order inside a word. Words which are formed by head movement have a morpheme order that mirrors the order of their underlying heads, whereas words formed by phonological merging maintain the underlying order of the syntactic heads. Both processes can also apply within one word showing different parts with different orders (Julien 2002).

---

<sup>1</sup>In the most recent proposal by Chomsky for the design of Agree Chomsky (2007, 2008), Agree is entirely reformulated in a way that does not fit the Bantu data well. The versions discussed here are Chomsky (2000) and Chomsky (2001).

The morpheme order of the prefixes of a Bantu verb basically corresponds to standard assumptions concerning universal hierarchical structures (Cinque 1999). This is shown in (1a) and (1b). Based on this structure, Julien argues that there is no head movement involved in creating the basic prefix structure of a Bantu verb.

- (1) a. Bantu verbal morphology: subject marker - tense- object marker - verb  
 b. Order of syntactic heads (Cinque 1999): AgrS/Fin-Tense-Aspect-V

The morpheme order of the suffixes in Bantu verbs does largely mirror the hierarchical order of the syntactic heads involved, as shown in (2).<sup>2</sup> In Bantu, an Appl (applicative), Caus (causative), Voice (passive) or TAM head is structurally higher than a verb head (Pykkänen 2002).

- (2) verb- causative- applicative- passive- aspect/mood/polarity

To illustrate Julien's structure, consider the Shona example in (3).

- (3) Á- cha- rí- téng- és- a.  
 SM1- FUT- OM- buy- CAUS- FV  
 'He/she will sell it.' [Shona, Julien 2002:195]

Julien's analysis is shown in (4) (Julien 2002:196). There is head movement in the lower part: V moves to Caus, adjoining to the left and forming a complex head. This head subsequently moves to M, again left-adjoining and forming a complex head. This means the verb raises to the position where the highest suffix head is located, not to T. The higher morphemes, including tense, the subject marker and the object marker are merged phonologically, not by head movement. In Julien's analysis, the object and subject are treated differently. The subject moves to the specifier of a functional projection: FinP. The head of FinP is the subject marker. FinP would presumably be considered an argument position in her theory, equivalent to spec,TP elsewhere.

The object, on the other hand, is a pronominal clitic which moves to a specifier position, where the object marker is spelt out morphologically. This corresponds to how Myers (1990) analyses Shona object markers. Julien follows his approach and Bresnan and Mchombo (1987)'s analysis for objects in Chichewa for Shona, based on the fact that Myers (1990) argues that, in Shona, objects which are doubled by an object marker are always definite. Julien (2002:197) calls the object marker an "incorporated pronoun" but this is not incorporation in the sense of Baker (1988a).

<sup>2</sup>See Hyman (2003) for an alternative view.

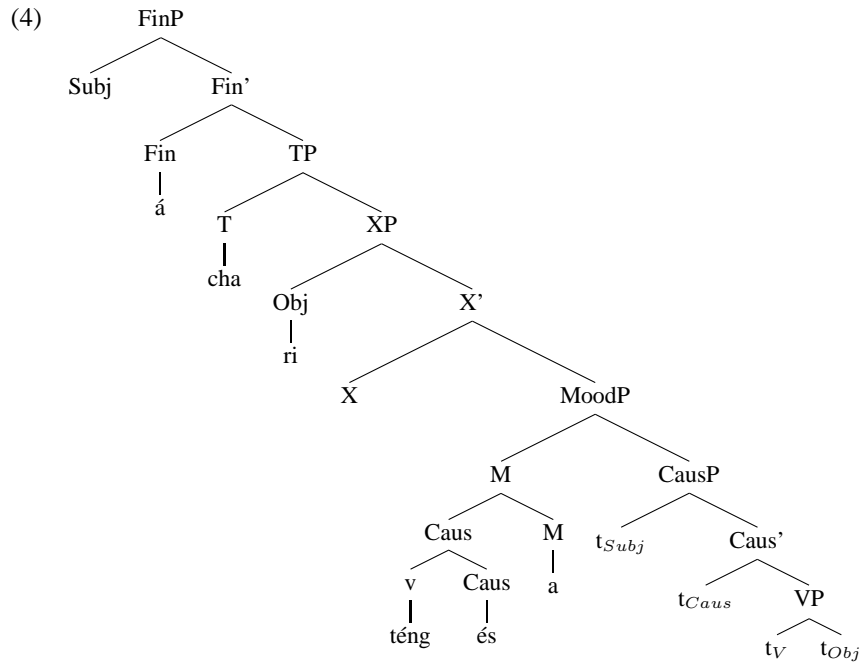

There are a number of problems with the structure in (4). Julien treats the final vowel as a mood marker and the head of MoodP. It is not clear how to analyse this position in syntax. Across Bantu, the subjunctive tends to be marked in this position. In a number of languages, negation also affects this morpheme. Although negation is marked in the final vowel slot in a number of Bantu languages, including Swahili, it is never marked only in the final vowel position but also encoded by a prefix. In Sambia, negation has no effect on the final vowel. However, in Sambia, apart from the subjunctive, both conjoint tenses are marked morphologically in this position. For simplicity, I will refer to this position as an aspectual head, and the head of AspP, in order to distinguish it from T and to allow for the spell-out of aspectual markers here. For a description of the complexities of tense aspect mood marking, see Roehl (1911) and Besha (1989a,b). Julien's structure also abstracts away from negation and relative markers, which can both appear in a number of places on the verb in Sambia. Julien actually points out that agreement morphemes do not tend to fit neatly into her system. For Bantu languages, adding agreement morphemes to the structure is not problematic, whereas negation, conjoint/disjoint forms, tense and verbal relative markers are harder to assign to a syntactic position. In spite of its shortcomings, this kind of structure captures the general differences between the suffixes and prefixes well and provides a plausible and simple account for the relationship between morphemes and heads which I will follow here. The crucial difference between Julien's structure and the one proposed here is the treatment of the object marker. As argued in chapter 3, I analyse

both Sambaa and Haya as having object agreement. This requires a different structure from the XP-movement account proposed by Julien.

Due to Julien's views of the behaviour of heads, Julien (2002) differs from most other accounts of Bantu syntax where the verb is assumed to raise as high as T (see for example Henderson 2006b; Kinyalolo 1991; Letsholo 2002). Some recent works on Bantu which follow Julien's assumptions include Buell (2005); Muriungi (2008); van der Wal (2009).

## 4.2 The syntax of Agree

**Agree** In chapter 3, I argued that Sambaa has syntactic object agreement. This means that I treat object marking as the morphological spelling out of an Agree relation between the object and a Probe. In current Minimalist syntax, Agree is generally defined as in (5), following Chomsky (2000, 2001).

- (5) **Agree:** A relationship between a Probe and a Goal, established under c-command.

Agree has the function of deleting uninterpretable features on Probe and Goal, such as structural case or  $\phi$ -features. According to Chomsky (2000:122), Agree requires a matching relation which involves three requirements, referred to as the matching condition: Match, as defined in (6).

- (6) a. Matching is feature identity.  
 b. D(P) is the sister of P.  
 c. Locality reduces to "closest c-command".

In (6), P stands for the Probe, and D(P) is the Domain of the Probe, which, as its sister, is the area that the Probe c-commands. This is illustrated in (7).

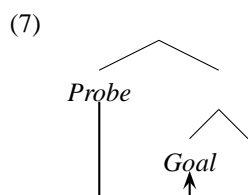

Closest c-command means that there is no other potential Goal matching P which contains the Goal to be agreed with. Following Chomsky (2000), this rules out the kind of Agree relations shown in (8) and (9). In both structures, XP2 is inside the domain of XP1. This makes Goal 1 the closest c-commanding Goal, and therefore, under closest c-command, Agree with Goal 2 is ruled out. In (8) the two Goals are specifiers of different phrases, while in (9) they are both specifiers of the same phrase.

(8)

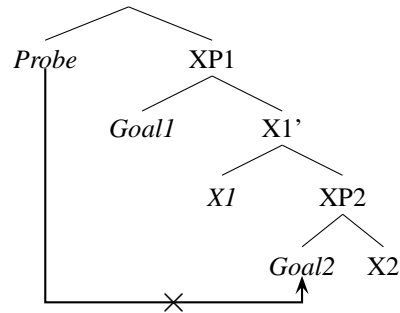

(9)

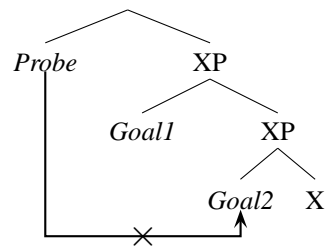

However, the locality conditions applying to Agree are specified by the Equidistance Principle and the Defective Intervention Constraint.

**Equidistance** Chomsky (2000) retains the “Equidistance Principle” from Chomsky (1995).

- (10) **Equidistance Principle:** Terms of the same Minimal Domain are equidistant to Probes. (Chomsky 2000:122)

Where the Minimal Domain is defined as the set of all entities contained within one maximal projection, as defined in (11).<sup>3</sup>

- (11) **Minimal Domain:** The Minimal Domain of a head H is the set of terms immediately contained in projections of H. (Chomsky 2000:123)

This is illustrated in (12). Because the specifier and the complement constitute a Minimal Domain of the head H, they are equidistant to any Probe.

<sup>3</sup>Hiraiwa (2001:68, example (5)) quotes a different definition, attributed to the same source. He states that Chomsky (2000:122) defines Equidistance as “Terms of the edge of HP are equidistant from Probe P.”

(12)

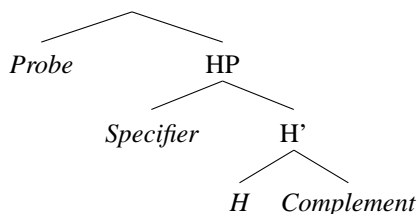

Under the Equidistance condition, Agree with Goal 2 is possible, in (9), but not in (8), since in (9) both Goals are part of the same domain. Moreover, this condition is problematic for object agreement patterns as seen for Sambia, since the indirect object and the direct object are inside the same Minimal Domain of the same head, namely V (assuming a Larsonian shell structure), as shown in (13). This means that the two objects would be equidistant by this definition and potentially could both trigger agreement. This matches the symmetric object marking patterns found in languages like Haya, as discussed in section 3.4.3, but not the object marking patterns found in Sambia.

(13)

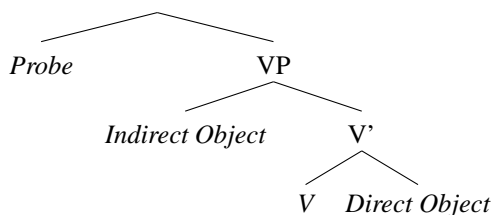

In Chomsky (2001), Equidistance is replaced by a condition stating that only the phonological edge of a phrase is accessible to a Probe. This would make Agree with a direct object impossible, unless that object were to move to a specifier position first. Since neither definition can account for grammatical and ungrammatical object marking patterns in Sambia, I will not adopt them here.

**The Defective Intervention Constraint:** Chomsky (2000:123) rules out Agree with several Goals under the Defective Intervention Constraint (DIC). This constraint rules out Agree configurations such as (14), where  $\alpha$  is a Probe and  $\beta$  and  $\gamma$  are both potential Goals, and  $\beta$  has deleted features.

(14)  $\alpha > \beta > \gamma$

This is illustrated structurally in (15).

(15)

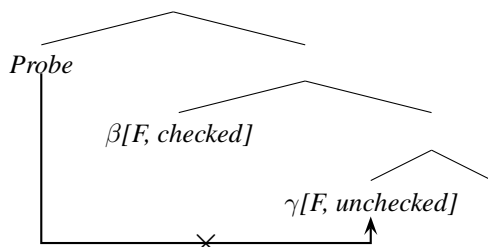

Hiraiwa (2001) interprets the DIC to mean that “checked features still matters [sic.] for locality” (Hiraiwa 2001:68), and that in the relevant context  $\beta$  has been checked by a Probe other than  $\alpha$ .

The model of the operation Agree proposed in Chomsky (2000) is based on the behaviour of subjects, not objects. This makes a condition like the DIC desirable, because languages universally allow only one subject.<sup>4</sup> Of the languages which allow agreement with an object, the majority allow agreement only with a single object, which is not too problematic since subjects and objects are checked by different heads. Although the lack of closest c-command violations triggered by the subject in spec, $\nu$ P must be accounted for, in a system where object agreement is with a Probe higher than  $\nu$  this would not create problems for the DIC. The subject moves before Agree takes place, and then it is no longer a possible intervenor. However, the agreement patterns in Smbaa double object constructions, are problematic with a condition like the DIC. Any object agreement with more than one object would be ruled out under the DIC. I will discuss this further in section 4.3.2.

**Multiple Agree** To avoid banning grammatical derivations in Japanese under the DIC, Hiraiwa (2001) proposed an operation called Multiple Agree. This involves simultaneous checking of several Goals by a single head, as shown in (16).



I will argue here that agreement with multiple objects in Smbaa is never simultaneous and that the DIC cannot be maintained for languages like Smbaa. However, in the final section it will be argued that for Bantu languages with only one object marking and asymmetric object marking the DIC can potentially be used to account for the grammatical and ungrammatical object marking patterns.

### 4.3 Object marking and Smbaa syntax

In this section, I apply the theoretical concepts introduced above to Smbaa object marking data. To account for the properties of Smbaa, I propose a modified version

<sup>4</sup>There are languages which allow multiple nominative marked DPs in a clause, such as Japanese (Hiraiwa 2001).

of Agree. I also cover some of the related issues which are relevant to Bantu languages more generally, including locative object markers. The main issues discussed here are: verb movement, subject marking, object marking, double object constructions and constructions with multiple object markers.

### 4.3.1 Subject agreement

In a Probe-Goal system, subjects could potentially interfere with object agreement. Let us start by looking at subject agreement in Smbaa. There is fairly good evidence from across the Bantu language family for movement of agreeing subjects to a specifier position above the verbal field (see Buell 2005; Carstens 2005; Henderson 2006b; Kinyalolo 1991; Letsholo 2002). This matches the SVO word order and subject agreement patterns in Smbaa, thus I will follow this here.

In Smbaa, the subject marker is obligatory irrespective of whether or not there is an overt subject DP, this is illustrated in (17).

- (17) (Uja ng'wana) (\*a)- za- bua.  
 1DEM 1child SM1- PERF.DJ- come  
 'That child has come.' [Smbaa]

Subjects can remain in situ. However, in this case, agreement with a locative noun class, not with the subject, appears on the verb. Class 17 is the noun class which is most commonly used with postverbal subjects but the other locative classes can also be used. The pattern looks like expletive agreement. In these constructions, the subject has a presentational focus reading. In (18a), this is with class 17 and in (18b) with class 16, both locative classes.

- (18) a. Ku- ka- awiya nyoka.  
 SM17- CONS- appear 9snake  
 'There appeared a snake.'  
 b. Ha- ka- awa mti.  
 SM16- CONS- come.out 3tree  
 'There came out a tree.' [Smbaa]

Apart from appearing in preverbal position or remaining in situ, without agreement, a subject can also be right-dislocated, as in (19). These cases are distinguishable prosodically from the sentences in (18), and differ syntactically insofar as expletive constructions are restricted to intransitives, while the subject of any kind of verb can be right-dislocated.

- (19) A- i- on- iye kitabu, Stella.  
 SM1- PRF.DJ- see- PERF.CJ 7book 1Stella  
 'She saw a/the book, Stella that is.' (disjoint) [Smbaa]

Consider the structure for a simple transitive sentence with an agreeing subject in preverbal position, as in (20).

- (20) Stella a- i- on- iye kitabu.  
 1Stella SM1- PRF.DJ- see- PERF.CJ 7book  
 ‘Stella saw a/the book.’ (disjoint) [Sambaa]

I argue that this sentence has the structure in (21). The subject *Stella* moves to spec,FinP, while the object remains in situ. The dotted arrow represents Agree, the non-dotted arrows indicate movement. Agree is triggered by Fin, following Julien (2002). Agree at Fin has also has an EPP feature, requiring the subject to move. The simplest possible feature structure for Agree in Bantu is using the noun class. This is because each noun class is either singular or plural and person agreement is expressed by separate morphemes which do not also show a noun class feature. In section 4.3.5 and chapter 6, I discuss the interaction between Agree and the features of DPs.

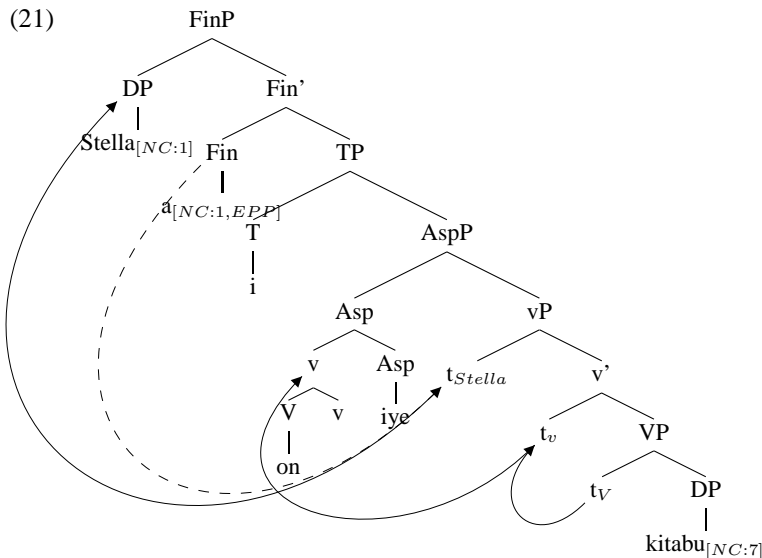

Henderson (2006b); Kinyalolo (1991); Letsholo (2002) and others have argued that subjects require a Spec-Head configuration in order to agree. Note that nothing in (21) prevents subject agreement with a postverbal subject. The Spec-Head configuration matches the basic word order and agreement properties of Samba subjects, insofar as agreeing subjects appear in preverbal position, while non-agreeing subjects appear in situ. However, the Spec-Head configuration does not fit into the Agree account of agreement. Agreement with a constituent that is above the Probe also does not follow from the standard Agree account. Baker (2008:161) actually combines both approaches in arguing that whatever moves to Spec,TP governs subject agreement in Bantu because it c-commands T. In general, Baker argues that agreement in Bantu is always upwards<sup>5</sup> Baker's approach does appear to have advantages for Bantu subjects,

<sup>5</sup>But he recognises that this is problematic for his analysis of Samba object agreement because in order to Agree twice v would need to search upwards and downwards (Baker 2008:200).

even though I do not follow his analysis for objects. The structure in (21) avoids these complications but it does not explain why postverbal subject do not tend to agree. I will leave this issue for future research and not discuss subject agreement further.

### 4.3.2 Object agreement

Movement is not required by any part of the definition of Agree in Chomsky (2000, 2001). This was a departure from Chomsky (1995) where agreement was argued to involve feature movement. However, in Chomsky (2000, 2001) a Probe may have an EPP feature as well as  $\phi$ -features. This is assumed to be the case for subjects in Bantu in the previous section. However, rather than assuming an EPP feature at T or Fin, most analyses of Bantu syntax which invoke Agree argue that movement is independently required for Bantu languages, either due to an EPP requirement on  $\phi$ -features or due to a spec-head configuration being required for Agree (Baker 2003; Carstens 2002, 2005; Henderson 2006a; Kinyalolo 1991). These accounts are based on the behaviour of subjects. There is no clear evidence that agreeing objects move to an argument position, although there are accounts involving movement outside of VP for objects (Woolford 1999, 2001). Many theoretical analyses do not treat object marking as agreement in Bantu and therefore never touch on the question of agreeing objects. Henderson (2006b) does discuss object agreement. He also quotes Kinyalolo (1991) on Bantu languages requiring a spec-head configuration for agreement. However, he does not specifically state whether he includes object agreement in this and whether he assumes objects that agree must move.

As mentioned above, Baker (2008:109) argues that Agree with person features requires movement. For Kinande, Baker (2003) argues that a verb agrees with an NP if and only if that NP is dislocated and attached in an adjunct position. Collins (2004) argues similarly for the entire Bantu family, although his evidence only comes from subjects in Swahili. Recalling the Sambia and Haya data discussed in chapter 3, it does not look as if object-marked objects are right-dislocated in either language. But, as we have seen, Bantu languages differ with regard to phrase-final tones and the distribution of the conjoint/disjoint forms. This would not rule out movement for agreement. However, unlike subjects in Bantu, objects do not visibly appear in a different syntactic position when they agree.

Consider the Sambia transitive sentence with object agreement in (22).

- (22) Stella a- i- chi- on- iye kitabu.  
 1Stella SM1- PRF.DJ- OM1- see- PERF.CJ 7book  
 ‘Stella saw a/the book.’ (disjoint) [Sambia]

If an agreed-with object had to move in Sambia, this would result in a structure where the object appears in the middle of the verb, as shown in (23). It has been argued by a number of Bantuists that the subject marker and the tense aspect marker form one syntactic constituent and the object marker and the verb stem form another (see Barrett-Keach 1986; Henderson 2006b; Myers 1987), but in no Bantu language can a full DP or any VP adjunct intervene between the two parts.

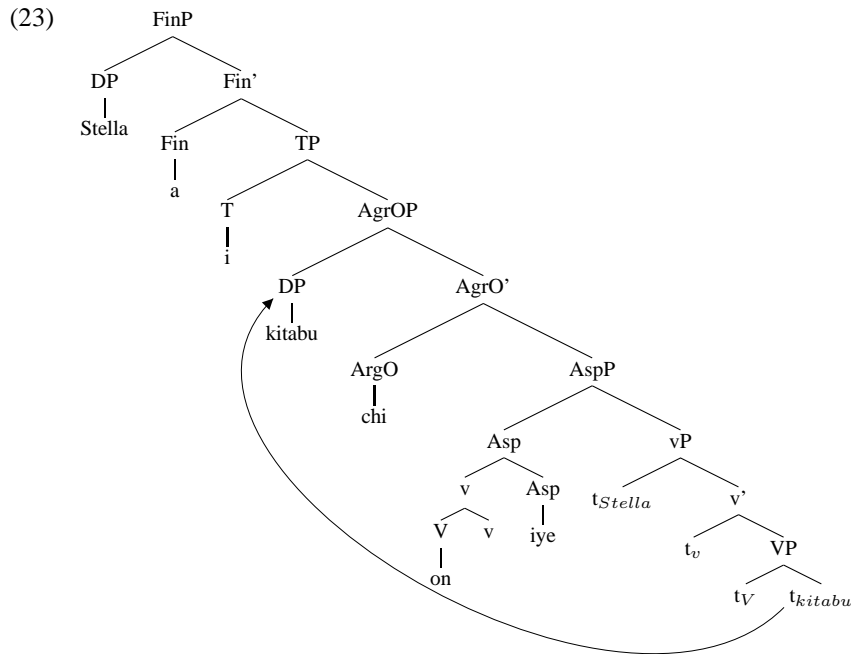

With an approach to morphosyntax which is different from the one argued for in Julien (2002), for example Checking Theory (Chomsky 1995; Ura 2000), one could argue that the verb raises to T (or Fin), past the hypothetically moved object in spec,AgrOP. This would get the right word order in a structure like (23). In Checking Theory, generally a verb is merged as a fully inflected form which will undergo Checking after Merge, rather than the individual heads and phrases we are assuming here. This means that under Checking Theory there is no relation between morpheme order and the syntactic heads. However, such an approach would encounter another problem. The word order of the direct object and the indirect object would be predicted to surface as SV DO IO when both objects agree and therefore move to specifier positions. Consider a ditransitive verb like *nka* ‘give’, as shown in (24).

- (24) Stella a- i- chi- m- nk- iye ng'wana kitabu.  
 1Stella SM1- PRF.DJ- OM7- OM1- give- PERF.CJ 1child 7book  
 ‘Stella gave the child the book.’ (disjoint) [Sambia]

If the agreed-with objects raise to spec,AgrOP or any specifier of vP, a structure such as (25) would result. Here the direct object appears before the indirect object and each object enters a spec-head agreement relationship with the relevant projection. If both objects agreed with the same Probe, one would still expect the order of DO IO with object-marking, unless the direct object “tucked-in” in a second specifier projection below the indirect object, which is theoretically undesirable.

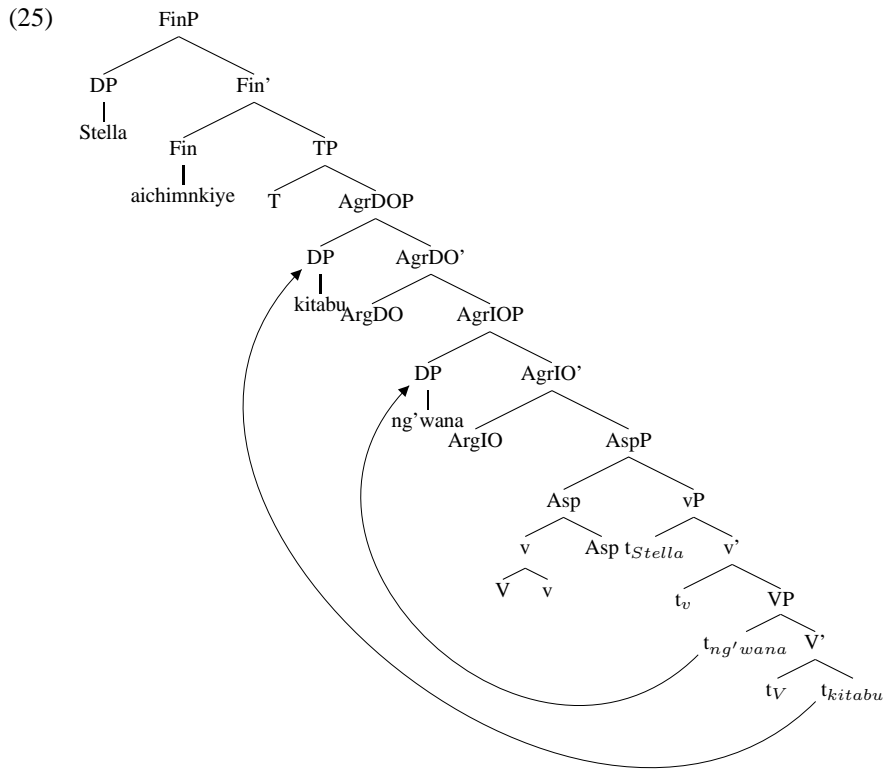

But as discussed in chapter 3, this order is ungrammatical, as shown in (26a). Moreover, recall that the order of morphemes which would correspond to the grammatical structure is also ungrammatical, as shown in (26b).

- (26) a. \* Stella a- i- chi- m- nk- iye kitabu ng'wana.  
 1Stella SM1- PRF.DJ- OM7- OM1- give- PERF.CJ 7book 1child  
 Int: 'Stella gave the child the book.' (disjoint)
- b. \* Stella a- i- m- chi- nk- iye ng'wana kitabu.  
 1Stella SM1- PRF.DJ- OM1- OM7- give- PERF.CJ 1child 7book  
 Int: 'Stella gave the child the book.' (disjoint) [Sambaa]

If an agreeing object remains in situ under application of Agree, as discussed in 4.2, the correct word order and morpheme order can be derived without adding any complications to the theory. This is shown in (27), corresponding to the sentence in (22). Agreement with more than one object is discussed further in the next section.

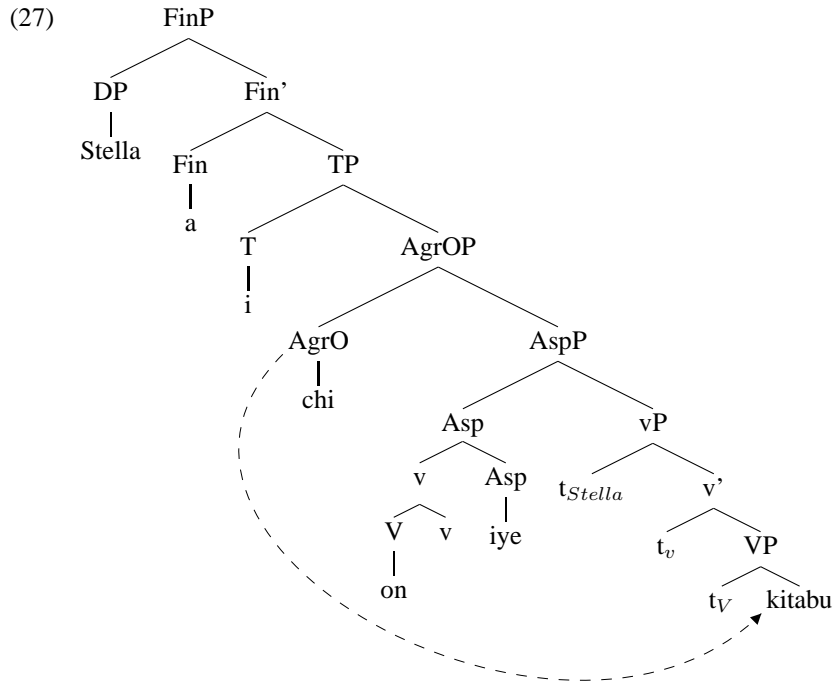

Since I treat the object markers as agreement morphemes rather than incorporated pronouns, I treat them as heads, following the structure Julien (2002) uses for subject markers. Because there are a number of possible agreement morphemes which appear in a consistent order, I label them based on the element they agree with. It would be possible to label all projections simply as AgrP.

### 4.3.3 Double object constructions

Having discussed the basic application of Agree, I now turn to the process of agreeing multiple times. Recall that Samba is a so-called asymmetric language. For asymmetric applicative constructions in Bantu, Marantz (1993) proposes a structure where the applied verb takes an event argument as its complement and the affected object as its specifier. This is shown in (28), where the object in spec,VP is what Marantz calls the “affected object”. For example, a benefactive, which is an argument of the entire predicate, that is, the lower VP which includes the theme object and the event.

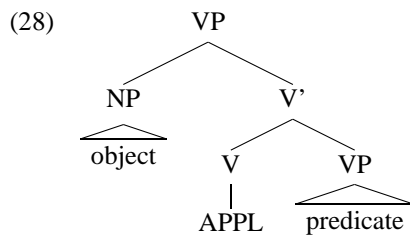

In terms of c-command asymmetries and distance from a Probe at AgrO, this structure is equivalent to the Larsonian structure introduced earlier, which is repeated in (29).

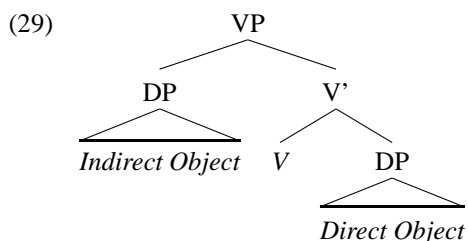

Marantz discusses c-command relations in applicative constructions in Swahili (data attributed to Vicki Carstens, p.c.). His examples are of possessive pronouns being bound by a quantifier. This works as a c-command test, because a quantifier has to c-command a pronoun in order to bind it. Marantz shows that the variable reading of the pronoun is available when the quantifier is in the benefactive argument NP and the pronoun in the theme. In (30a) this is also the linear order. In Swahili the surface order of the two arguments can be reversed, as shown in (30b), yet the same c-command relations hold.

- (30) a. Ni- li- m- somea [kila mwandishi]<sub>i</sub> kitabu chake<sub>i</sub>.  
 SM1- PAST- OM1- read.APPL every 1writer 7book 7his  
 'I read for each author his book.'
- b. Ni- li- m- somea kitabu chake<sub>i</sub> [kila mwandishi]<sub>i</sub>.  
 SM1- PAST- OM1- read.APPL 7book 7his every 1writer  
 'I read for each author his book.' [Swahili, Marantz 1993:117]

In contrast, if the pronoun is contained within the benefactive NP, the pronoun cannot be bound by the quantified direct object irrespective of the word order. This is shown in (31a) where the quantifier precedes the pronoun, and in (31b) where the pronoun precedes the quantifier. Marantz labels these sentences ungrammatical. However, my informant found both sentences in (31) completely acceptable, but not with the pronominal variable reading. This means there are differences in word order but not in the available scope interpretation.

- (31) a. % Ni- li- m- somea [kila kitabu]<sub>i</sub> mwandishi wake<sub>k/\*i</sub>.  
 SM1- PAST- OM1- read.APPL every 7book 1writer lits  
 'I read [each book]<sub>i</sub> for his/her author<sub>k/\*i</sub>.'  
 \* 'I read for its author each book.' (reading discussed in Marantz 1993)
- b. % Ni- li- m- somea mwandishi wake<sub>i</sub> [kila kitabu]<sub>k/\*i</sub>.  
 SM1- PAST- OM1- read.APPL 1writer lits every 7book  
 % 'I read his/her author [each book]<sub>i</sub>.'  
 \* 'I read its author each book.' (reading discussed in Marantz 1993)  
 [Swahili, Marantz 1993:117, modified]

This means that in Swahili the indirect object c-commands the direct object, but not vice versa, irrespective of surface word order. The same scope relations hold in Smbaa, as shown in (32). Since Smbaa does not allow the order V DO IO, there are no differences between surface order and c-command.

- (32) a. N- za- m- somea [kia mwandisi]<sub>i</sub> kitabu chakwe<sub>i</sub>.  
 SM1- PERF.DJ- OM1- read.APPL every 1writer 7book 7his  
 ‘I read for each author his book.’
- b. N- za- m- somea mwandisi wakwe<sub>i</sub> [kia kitabu]<sub>k/\*i</sub>.  
 SM1- PERF.DJ- OM1- read.APPL 1writer 1its every 7book  
 ✓ ‘I read for his author every book.’  
 \* ‘I read for its author each book.’ [Smbaa]

We have established that the strict word order in Smbaa corresponds to the c-command relations expected by an analysis to double object constructions in Bantu such as the structure by Marantz in (28). Now, turning to the availability of object marking for each object, recall the accessibility hierarchies established in chapter 3: IO > DO > Loc. Where the indirect object does not trigger obligatory object marking there are several grammatical patterns: no objects can agree, as in (33a); only the indirect object can agree, as in (33b); both indirect and direct object can agree, as in (33c). It is not grammatical for only the direct object to agree, as in (33d).

- (33) a. N- za- nka ng’wana kitabu.  
 SM1S- PERF.DJ- give 1child 7book  
 ‘I gave the child a book.’ (no OM)
- b. N- za- m- nka ng’wana kitabu.  
 SM1S- PERF.DJ- OM1- give 1child 7book  
 ‘I gave the child a book.’ (OM for IO)
- c. N- za- chi- m- nka ng’wana kitabu.  
 SM1S- PERF.DJ- OM7- OM1- give 1child 7book  
 ‘I gave the child a book.’ (OM for IO and DO)
- d. \* N- za- chi- nka ng’wana kitabu.  
 SM1S- PERF.DJ- OM7- give 1child 7book  
 Int: ‘I gave the child a book.’ (OM for DO but not IO) [Smbaa]

The fact that an intermediate stage is possible: agreeing once (as in (33b)), means that this does not work with Multiple Agree, following Hiraiwa (2001), where Agree happens simultaneously. Rather, it looks like several cycles of Agree Closest take place, one for each head. There is also no Defective Intervention Effect. Only an unvalued feature causes intervention effects.

The sentence in (33b), has the derivation shown in (34). The Probe, AgrO, searches and finds the indirect object *ng’wana* first and enters into an Agree relation with it.

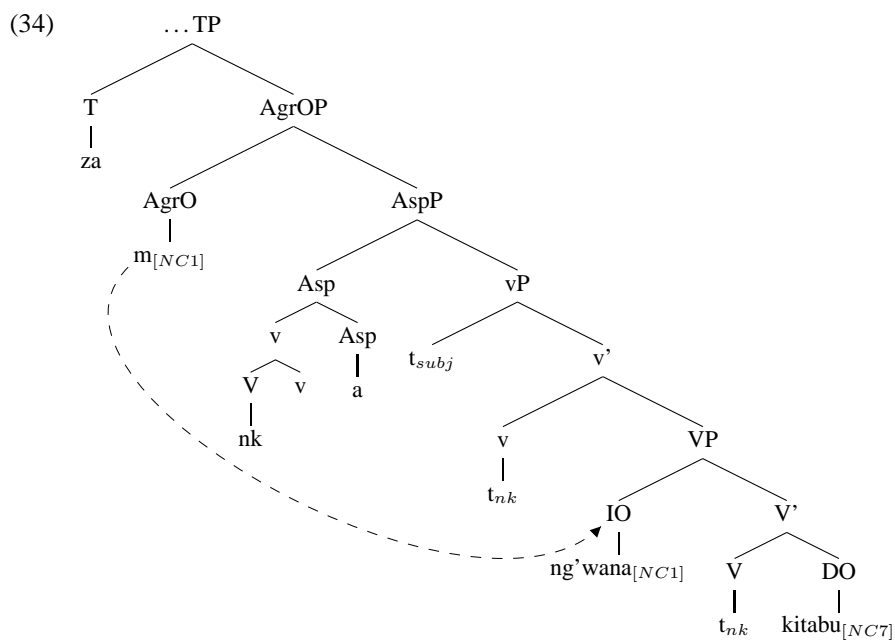

The derivation in (35), corresponding to (33d), crashes under Closest c-Command, since the indirect object *ng'wana* is closer. This shows that Chomsky's (2000) principle of Equidistance does not hold for Sambia Agree. Under that definition, the two objects would be equidistant to the Probe. However, using Hiraiwa's (2001) restatement of the constraint as applying to terms on the edge of a phrase, they would not be equidistant.

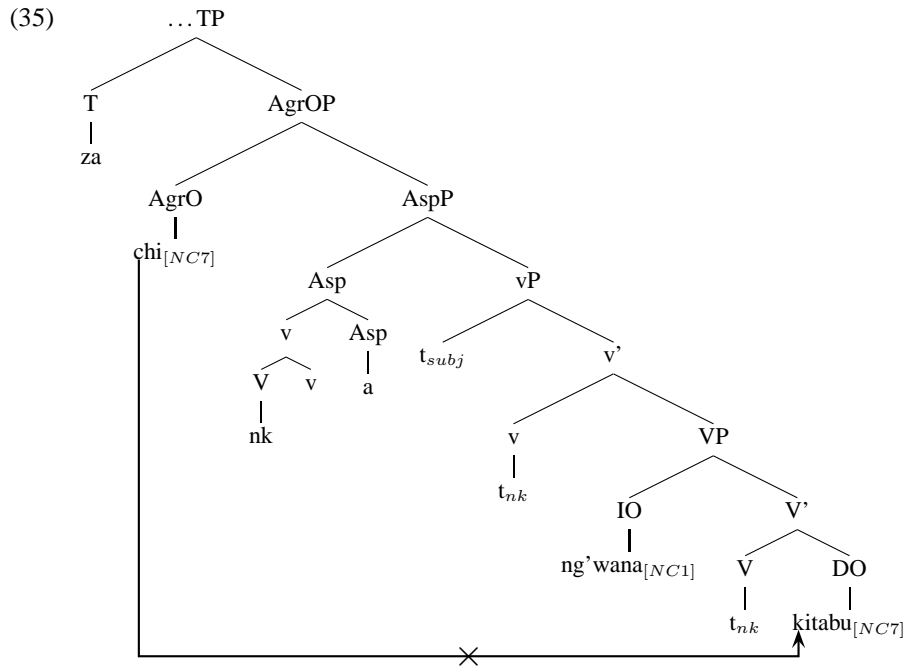

However, once the features of the indirect object are checked, the features of the direct object can be checked too, as in the sentences in (33c). This is shown in (36). This derivation would be expected to crash, following Chomsky's DIC, as defined in (14). The fact that it is grammatical shows that DPs with checked features do not block Agree for DPs with unchecked features in their domain, while DPs with unchecked features do. Thus, the DIC does not hold for Sambia. Moreover, the condition on only the edge of a phrase being visible for Agree in Chomsky (2001) would rule out agreement with the direct object. Not only in this case but also in mono-transitives such as (22).

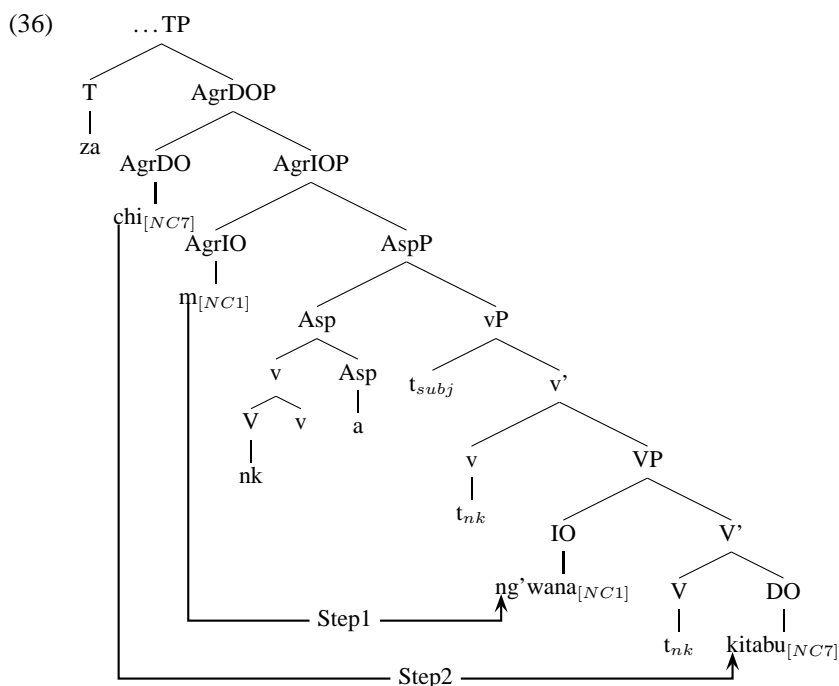

There is something more unusual about the features in Samba. For nouns such as *ng'wana*, the features do not need to be checked, as sentences such as (33a) show. Since there is a clear difference between agreed-with DPs and not agreed-with DPs in double object constructions, insofar as a non-agreed-with DP blocks agreement with a lower DP while an agreed-with DP does not, it is unlikely that those features are checked at all. Moreover, since Bantu languages which allow more than one object marker don't tend to limit the number of object markers syntactically, it makes sense to assume that AgrO heads are not present when there is no object marking. But what happens with the DPs? According to Chomsky (2000), Agree requires active features on Probe and Goal. Since unchecked features are assumed to cause a derivation to crash, this is problematic. As shown in chapter 3, Agree is optional for most nouns in Samba. But for a number of nouns it is not; moreover, when the indirect object has not been object-marked it blocks object marking for the direct object.

#### 4.3.4 Locative object marking

In chapter 3, sentences are discussed, where aside from the direct object or an indirect object a locative noun can also be object-marked. Locative object marking is subject to the same hierarchical restrictions as object marking for direct objects in double object constructions. (37a), where the indirect object is marked is acceptable, while without object marking the indirect object, as in (37b) and (37c), object marking the locative phrase is ungrammatical. The judgements for, (37d), where only the indirect object and the locative are marked, are mixed, with most speakers rejecting the sentence.

- (37) a. N-    za-    ha-    chi- m-    nka ng'wana kitabu haja.  
 SM1S- PERF.DJ- OM16- OM7- OM1- give 1child 7book 16there  
 'I gave the child a book there.' (OM for IO, DO and Loc)
- b. \* N-    za-    ha-    chi- nka ng'wana kitabu haja.  
 SM1S- PERF.DJ- OM16- OM7- give 1child 7book 16there  
 Int: 'I gave the child a book there.' (OM for DO and LOC but not IO)
- c. \* N-    za-    ha-    nka ng'wana kitabu haja.  
 SM1S- PERF.DJ- OM16- give 1child 7book 16there  
 Int: 'I gave the child a book there.' (OM for LOC but not IO or DO)
- d. %/\* N-    za-    ha-    m-    nka ng'wana kitabu haja.  
 SM1S- PERF.DJ- OM16- OM1- OM1- give 1child 7book 16there  
 Int: 'I gave the child a book there.' (OM for Loc and IO but not DO)

[Smbaa]

Unlike double object constructions, locative object marking patterns vary slightly in terms of grammaticality judgements. Some speakers do not like constructions with three object markers, and, occasionally, constructions such as (37d) are judged acceptable. This is not too surprising, seeing as these constructions are very complex morphologically and are extremely rare in natural speech. However, there is a clear and consistent contrast between (37a), on the one hand, and (37b) and (37c), on the other.

For locatives Haya, Swahili and Smbaa have the same word order restriction: a locative must come after both objects or in clause initial position. Locatives are different from other DPs as they can be object-marked without being reflected in the argument structure. In (37) the locative is not an applied object, *nka* 'give' is an un-derived ditransitive verb. Locative object marking is also possible with intransitive verbs which cannot be object-marked for any other kind of DP, as shown in (38a), an object-marked object can be licensed by an applicative in this case, as shown in (38b). Locative object marking is grammatical in intransitive verbs, as shown in (38c) and in monotransitive verbs with object marking for the direct object, as shown in (38d).

- (38) a. \* N-    za-    m-    bua (Juma).  
 SM1S- PERF.DJ- OM1- arrive 1Juma  
 'I arrived (to) him/Juma.'
- b. N-    za-    m-    buia    (Juma).  
 SM1S- PERF.DJ- OM1- arrive.APPL 1Juma  
 'I came across Juma' (lit. I arrived (to) Juma.)
- c. N-    za-    ha-    lala.  
 SM1S- PERF.DJ- OM16- sleep  
 'I slept there.'
- d. A-    za-    ha-    mu-    ona.  
 SM1- PERF.DJ- OM16- OM1- see  
 'He saw him there.'

[Smbaa]

In Swahili, Smbaa and Haya a postverbal locative must come after both objects, and is c-commanded by the direct object. This is shown for each language in (39). Marantz (1993) also argues that in Bantu linear order matches c-command relations.

- (39) a. N- za- mu- onyesha mwana [kia mnyama]<sub>i</sub> sehemu yakwe<sub>i</sub>.  
SM1S- PERF.DJ- OM1- show 1child every 1animal 9place 9POSS  
'I showed the child every animal in its place.' [Smbaa]
- b. Ni- li- mw- onyesha mtoto [kila mnyama]<sub>i</sub> nyumbani kwake<sub>i</sub>.  
SM1S- PAST- OM1- show 1child every 1animal 9house.loc 17POSS  
'I showed the child every animal in its place.' [Swahili]
- c. N- k- olekya omwana [buli kigunju]<sub>i</sub> ekayakyo<sub>i</sub>.  
SM1S- PAST3- show 1child every 7animal 9house.7POSS  
'I showed the child every animal in its place.' [Haya]

This indicates that, in Bantu, locative adjuncts are lower than direct objects. Adger and Tsoulas (2004) discuss c-command relations for locatives in English and come to the same conclusion. They discuss two proposals. In the first one, locative objects are generated in a specifier of vP, as shown in (40), which is attributed to Cinque (1999). In the second proposal, locatives are generated as a complement of v with the VP in a specifier position of vP, as shown in (41), attributed to Nilsen (1998). However, in neither of the proposals would the direct object c-command the locative. In (40) the locative is higher than the direct object, and in (41) the direct object is too deeply embedded to c-command the locative.

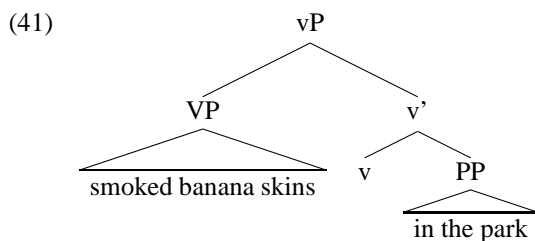
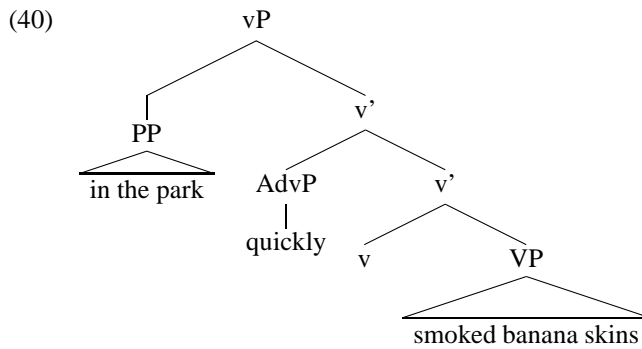

The left adjunction structure proposed by Cinque is problematic in terms of word order and c-command. An alternative structure, with the locative adjoined to the right,

as shown in (42), would also have the wrong c-command relation with the expectation that it is the first DP which requires object marking.

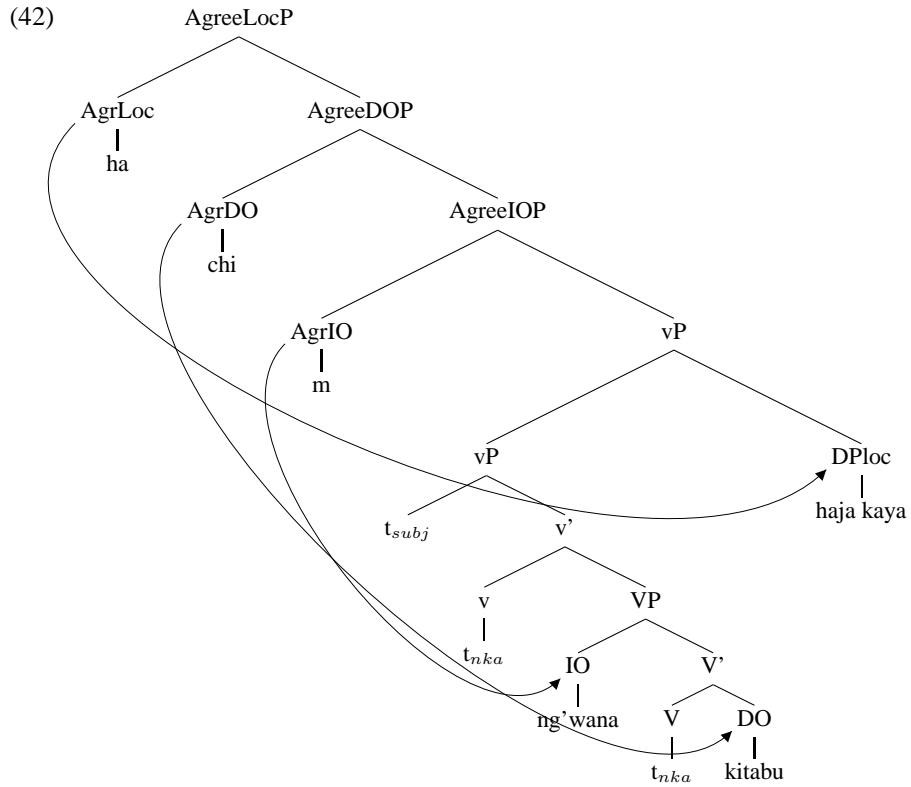

They argue for a structure with a locative above VP but where the object eventually moves to an AgrO head above the locative. This is illustrated in (43).

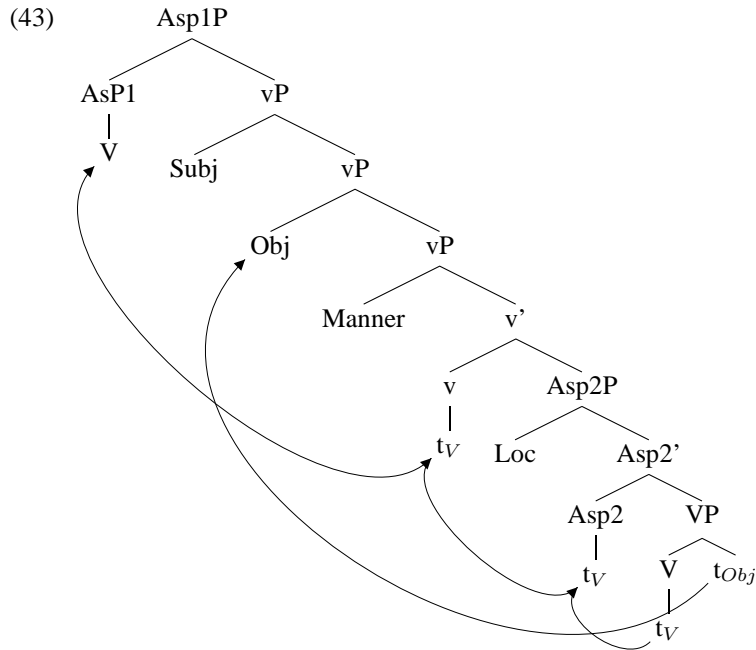

Adger and Tsoulas (2004) argue that (43) is the right structure based on the interaction of locative phrases with the aspect of a predicate. In English, dropping the preposition changes the telicity. A preposition-less predicate, as in (44a), denotes a completed action, whereas the predicate with the preposition, as in (44b) does not have this reading (Adger and Tsoulas 2004:2).

- (44) a. They climbed the mountain.  
b. They climbed up the mountain.

The structure proposed by Adger and Tsoulas (2004) would work for languages like Samba. However, entities which have moved and thereby had their structural case checked are argued to be frozen for further syntactic operations (Chomsky 2000:123). This would rule out object agreement.

A small clause analysis of the locative as being a predicate of the direct object would get the right hierarchical relations for the word order, morpheme order and accessibility hierarchies. This is shown in (45).

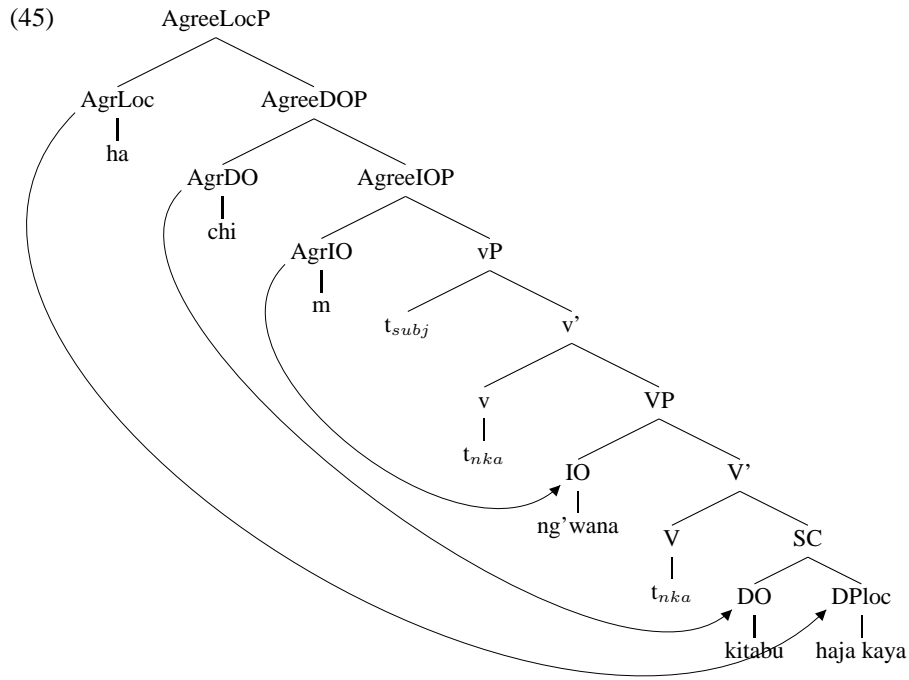

Marantz (1993:125) proposes one structure for locative applicatives in Chichewa and Chaga, shown in (46). Note that this structure would allow for precisely the right c-command relations and word order facts for Samba locatives.

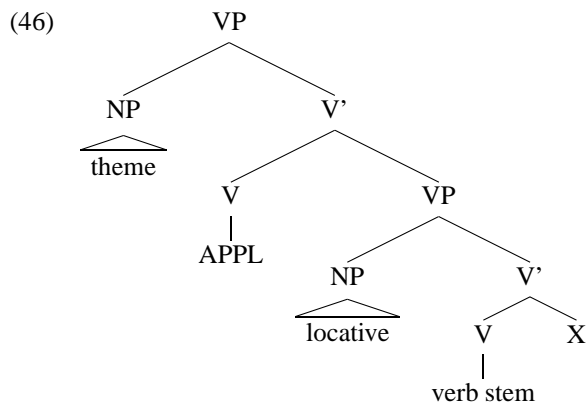

However, this structure is for locative applicatives, but there is no applicative morpheme with the Samba locatives discussed in this section. Locative applicatives also occur in Samba, and apparently have somewhat different properties. The Samba-type construction without an applicative is not dealt with in the Bantu literature on object marking. Nor is it a pattern which is common cross-linguistically. Further in-

vestigations into agreement with applicative and non-applicative locatives is needed to determine which structure is best. This will be left for future research.

### 4.3.5 Feature structure and obligatory object marking

In chapter 3, nouns which trigger obligatory object marking in Sambia were discussed. It was shown that this group includes proper names for humans, first and second person pronouns, kinship terms and titles but does not include any particular noun class, nor does it apply to human, animate, definite or specific DPs more generally. We can say then, that the Person features [+1st] and [+2nd] and the combination of [+hum,+referential] require object agreement. With those features an object triggers object marking. However, this is only required for the highest object. In a monotransitive clause, a direct object with those features requires object marking, as shown in (47a), but in a ditransitive the direct object does not require object marking even if it has those features, as shown in (47b).<sup>6</sup> As expected, object marking a DP with person features which is embedded in a PP is ungrammatical. This is illustrated in (47c) and (47d).

- (47) a. \* Stella a- za- ona imi.  
 1Stella SM1- PERF.DJ- see me  
 Int: ‘Stella saw me.’
- b. Juma a- za- tambulishiza wavyazi wakwe Sauda.  
 1Juma SM1- PERF.DJ- introduce.APPL 2parent 2.POSS.3S 1Sauda  
 ‘Juma introduced Sauda to his parents.’
- c. Stella a- za- (\*ni-) iza na imi.  
 1Stella SM1- PERF.DJ- OM1S- come with me  
 ‘Stella came with me.’
- d. Stella a- za- (\*ni-) iza kwa imi.  
 1Stella SM1- PERF.DJ- OM1S- come 17.ASSOC me  
 ‘Stella came to me.’ [Sambia]

A derivation such as (48), corresponding to the sentence in (47a), crashes at the point where the object with person features is encountered by the Probe.

<sup>6</sup>See the discussion in chapter 3 and section 4.3.3 for the accessibility restrictions on multiple object marking.

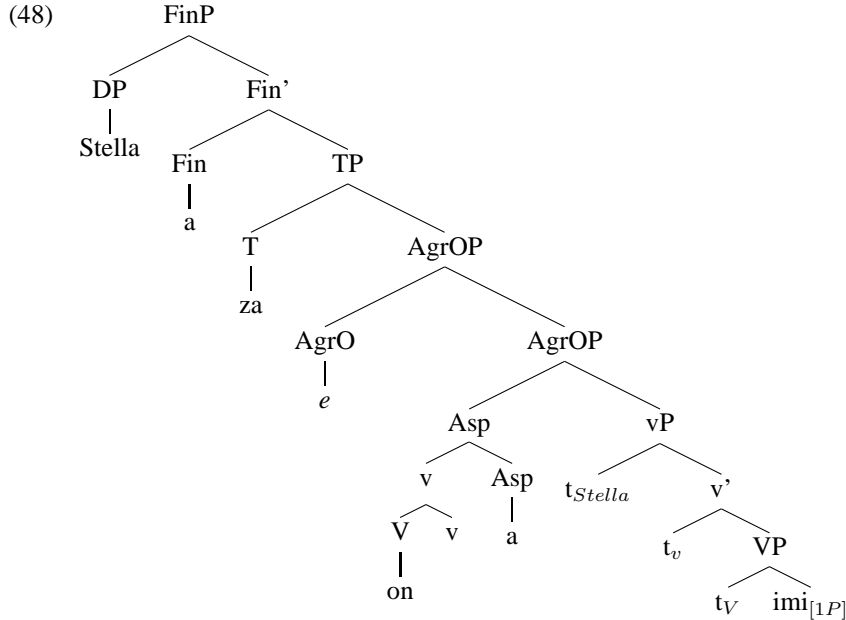

According to Chomsky (2000, 2001) both the Probe and the Goal need to be active for Agree. It is not clear that this restriction is required, since active features on one element seems to be enough to trigger the Agree operation. However, if both the Probe and the Goal have active features, this would mean that any object which is not object-marked would cause a grammaticality violation. This problem can be avoided by requiring only a Probe to have active features. In Smbaa, this requirement would cause most naturally spoken sentences (in terms of frequency of use) to be ungrammatical, because object marking is rare for most types of objects, and multiple object marking is extremely uncommon.  $\phi$ -features on nouns are interpretable, this means they do not require to be deleted as such. A Probe searching for  $\phi$ -features will see them. This allows for the grammatical Smbaa sentences with objects but no object agreement.

For Smbaa, we do not want to let agreed-with objects block lower objects from agreeing. If Agree deletes the  $\phi$ -features of the Goal, an agreed-with object will be invisible to a subsequent Probe, which would allow for constructions with multiple object markers. However, it would not explain the ungrammaticality of (48). If active  $\phi$ -features are taken to be like EPP features, some DPs would have them while others do not. In a language like Smbaa first and second person features and the bundle [+hum, +referential] are active and cause a derivation to crash if unchecked. Again this visibility seems to be restricted by locality since it affects only the object which is closest to the Probe and only when the object is inside a DP which is not embedded inside a PP.

### 4.3.6 Agreement and case

Bantu object markers do not have morphological case. The object marker has the same morphological form regardless of whether it agrees with a direct object or an indirect object. This is illustrated in (49a), where the object is the patient and in (49b), where the object-marked object is the beneficiary; in both cases the object marker for the second person singular is *ku*. In fact, only in a few cases, notably for second person and class 1/2, is there a morphological difference between the subject marker and the object marker. The shape of the subject marker for second person singular is *u*, as shown in (49c).

- (49) a. A- za- ku- toa. (object is the patient)  
SM1- PERF.DJ- OM2S- hit  
'He hit you.'
- b. A- za- ku- toea simu. (object is the beneficiary)  
SM1- PERF.DJ- OM2S- hit.APPL 9wire  
'He called you (lit. hit the wire for you).'
- c. U- za- bua.  
SM2S- PERF.DJ- arrive  
'You (have) arrived.'
- [Sambaa]

There is no ambiguity for the thematic role of each argument because of the position of the morpheme in the verbal morphology. The subject marker precedes tense and the object marker follows tense. As was shown in chapter 3, the object markers in the vast majority of the Bantu languages are strictly ordered with regard to each other. Arguably then, there is no real case syncretism in the sense of Adger and Harbour (2007). Objects are licensed independently of agreement, since agreement is not always required and there are several cases of grammatical objects which cannot be object-marked. This indicates that structural case and object agreement are not related in Bantu.

**Prepositional phrases** In section 4.3.4, I discussed the c-command relations, word order and morpheme order of locative object-marked entities and other objects. In this section, I will propose that the kind of locative phrases are syntactically not PPs but DPs and show that PPs never enter Agree relations, and are never reflected in the argument structure of the verb.

Prepositional phrases can never be object-marked in Sambaa. The prepositional element *kwa*, which is a locative-marked associative that could be compositionally translated as 'at' or 'of', has a benefactive or goal reading. This is shown in (50a). A DP complement of *kwa* cannot be object-marked, as shown in (50b). A benefactive is a bare noun and is the complement of an applicative verb. It can be object-marked, or in the case of a proper name, has to be object-marked, as illustrated in (50c). Such an applied benefactive cannot appear as a complement of *kwa* and cannot be object-marked, as shown in (50d).

- (50) a. N- za- soma kwa Juma.  
SM1S- PERF.DJ- read 17.ASSOC 1Juma  
'I read to Juma.'
- b. \* N- za- m- soma kwa Juma.  
SM1S- PERF.DJ- OM1- read 17.ASSOC 1Juma  
Int: 'I read to Juma.'
- c. N- za- m- somea Juma.  
SM1S- PERF.DJ- OM1- read.APPL 1Juma  
'I read to Juma.'
- d. \* N- za- (m-) somea kwa Juma.  
SM1S- PERF.DJ- OM1- read.APPL 17.ASSOC 1Juma  
Int: 'I read to Juma.'
- [Sambaa]

In section 3.4.4, object marking and asymmetry in the passive were discussed. Reconsider the data from example (99), which is repeated in (51), in (51a) *kui* 'dog' is a beneficiary. However, as a bare noun in this construction, it cannot have a beneficiary interpretation, as shown in (51b).

- (51) a. Ng'ombe zi- za- onyeshwa kwa kui.  
10cow SM10- PERF.DJ- show.PASS 17ass 5dog  
'The cows were shown to the dog.'
- b. Ng'ombe zi- za- ji- onyeshwa kui.  
10cow SM10- PERF.DJ- OM5- show.PASS 5dog  
✓ 'The cows were shown a/the dog.'  
\* 'The cows were shown to the dog.'
- c. \* Ng'ombe zi- za- ji- onyeshwa kwa kui.  
10cow SM10- PERF.DJ- OM5- show.PASS 17ass 5dog  
Int: 'The cows were shown to the dog.'
- [Sambaa]

The data in (50) and (51) show that only DPs can interact with the verbal argument structure and only DPs can be object-marked. However, it is not the case, that only objects which are reflected in the argument structure can be marked. Since non-applied locatives, which look and behave like adjuncts, can also be object-marked.

For locative nouns, again only DPs can be object-marked, not PPs. A number of motion verbs in Sambaa can take either a DP complement, as in (52a), or a prepositional complements, as shown in (52b), apparently in free variation.<sup>7</sup> The DP form can be object-marked with a locative object marker, as in (52c), while the PP form cannot be object-marked, as shown in (52d).

- (52) a. A- za- bua kaya.  
SM1- PERF.DJ- arrive home  
'He arrived home.'

<sup>7</sup>I could find no difference in meaning between the two variants. Both are used frequently in natural speech by the same speakers.

- b. A- za- bua na kaya.  
SM1S- PERF.DJ- arrive with home  
'He arrived at home.'
- c. A- za- ha- bua kaya.  
SM1- PERF.DJ- OM16- arrive home  
'He arrived home.'
- d. \*A- za- ha- bua na kaya.  
SM1S- PERF.DJ- OM16- enter with home  
Int: 'He arrived home.'
- [Sambaa]

There is a difference between locatives and other DPs for object marking, but for any noun phrase object marking is only possible if it is not embedded inside a PP.

**Applicatives** Pylkkänen (2002) proposes that Bantu applicatives are high because they can be combined with unergative verbs. Pylkkänen (2002) uses “high” in the sense that the applicative head is structurally higher than VP, irrespective of its thematic function as introducing benefactives, instrumentals, etc, and proposes the structure shown in (54), corresponding to the sentence in (53).

- (53) N- a- y- lyi- i- a mka keyla.  
FOC- SM1 PRES- eat- APPL- FV 1wife 7food  
'He is eating food for his wife.'
- [Chaga, Pylkkänen 2002:17]

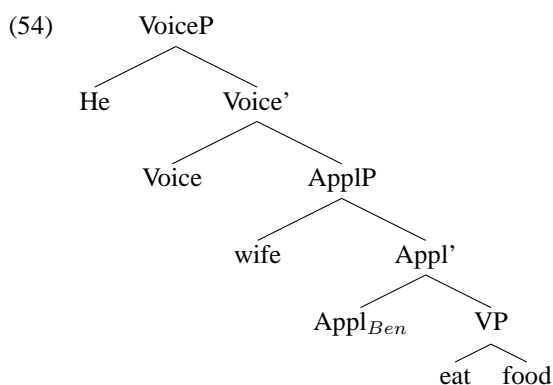

Applicatives denote a relationship between an event and an individual, where the indirect object asymmetrically c-commands the direct object (Pylkkänen 2002). However, as Marantz (1993) points out, there are clear differences in Bantu between benefactive applicatives and instrumental applicatives. He suggests the structure, in (56), for the Chichewa benefactive in (55). The structure he proposes for instrumentals, shown in (61), is discussed below.<sup>8</sup>

<sup>8</sup>To account for word order variation with instrumentals and locatives in Chichewa and Chaga, Marantz (1993:124) suggests two structures with different scope relations. Sambaa does not show this variation, and only the structure which is relevant for Sambaa is discussed here.

- (55) Chitsiru chi- na- gul- ir- a 2atsikana mphantso.  
 7fool SM7- PAST- buy- APPL- FV 2girl 3gift  
 ‘The fool bought a gift for the girls.’ [Chichewa, Marantz 1993:129]

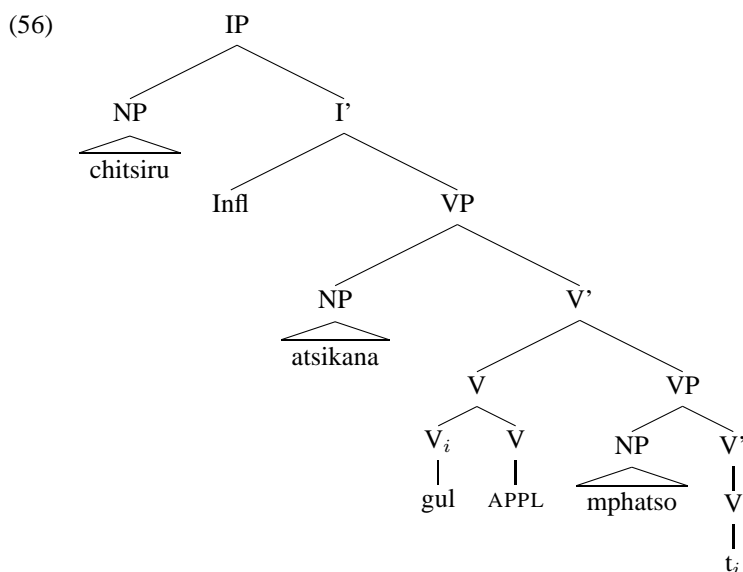

He argues that this is derived from a Larson-style VP-shell structure where the verb has been incorporated into the applicative, following Baker (1988a). This is similar to a modern structure, like the one used in this thesis, following Julien (2002), except for the position of the direct object. For Marantz, the direct object is located in a specifier position, rather than in a complement position.

**Instrumentals** In Sambia, instrumental applicatives are only robustly grammatical for most speakers with infinitives (see also Roehl 1911:185). An example of this is shown in (57a). This construction is ungrammatical without the applicative morpheme, as in (57b).

- (57) a. tuni ja ku- shengea mkate  
 5knife 5ASSOC INF- cut.APPL 3bread  
 ‘bread knife/knife for cutting bread’  
 b. \*tuni ja ku- shenga mkate  
 5knife 5ASSOC INF- cut 3bread  
 ‘bread knife/ knife for cutting bread’ [Sambia]

Instruments can be expressed in a prepositional phrase with *na* ‘with’, as shown in (58a). These must follow the direct object. The reverse order is ungrammatical as shown in (58b). The same holds for applicative instrumentals, as shown in (58c). There is a contrast between this order and the order DO > Instrumental, which is some speakers accept, as shown in (58d). Instrumentals, thus, have different word order

preferences from benefactive objects, despite being encoded by the same morpheme: the applicative marker.

- (58) a. Ni- sheng- iye nkuni na hamba.  
SM1S- cut- PERF.CJ 9firewood with 5machete  
'I cut the firewood with a machete.'
- b. \* Ni- sheng- iye na hamba nkuni.  
SM1S- cut- PERF.CJ with 5machete 9firewood  
Int: 'I cut the firewood with a machete.'
- c. \* Ni- shengee hamba nkuni.  
SM1S- cut.APPL.PERF.CJ 5machete 9firewood  
'I cut the firewood with a machete.'
- d. % Ni- shengee nkuni hamba.  
SM1S- cut.APPL.PERF.CJ 9firewood 5machete  
'I cut the firewood with a machete.'
- [Sambaa]

Some speakers did not like these constructions unless the direct object was dropped or dislocated. This is shown in (59a) with a right-dislocated direct object and in (59b) for a dropped (but object-marked) direct object. Slightly similar effects are reported for Swahili in Ngonyani (1996), where the instrumentals also only grammatical with extraction.

- (59) a. Ni- u- shengee hamba, mkate.  
SM1S- OM3- cut.APPL.PERF.CJ 5machete 3bread  
'I cut it with a machete, the bread.' [Answer to: What did you do with the knife and the machete?]
- b. Ni- u- shengea hamba.  
SM1S- OM3- cut.APPL.PRES.CJ 5machete  
'I cut it (the bread) with a machete.'
- [Sambaa]

Unlike locatives, direct objects and indirect objects, instrumentals cannot be object-marked in Sambaa, as shown in (60c). This is ungrammatical when both objects are marked, with both the morpheme order Inst > DO, as shown in (60b) and with the order DO > Inst, as shown in (60c).

- (60) a. \* Ni- ji- shengea (hamba) (mkate).  
SM1S- OM5- cut.APPL.PRES.CJ 5machete 3bread  
'I cut it (the bread) with a machete.'
- b. \* Ni- u- ji- shengea hamba mkate.  
SM1S- OM3- OM5- cut.APPL.PRES.CJ 5machete 3bread  
Int: 'I cut the bread with a machete.'
- c. \* Ni- ji- u- shengea.  
SM1S- OM5- OM3- cut.APPL.PRES.CJ  
Int: 'I cut it (the bread) with it (the machete).'
- [Sambaa]

Marantz (1993:124) suggests a structure for Chichewa and Chaga where the instrumental applicative is merged in the specifier of the lower VP (in a structure with two VP projections instead of vP and VP). This is shown in (61).

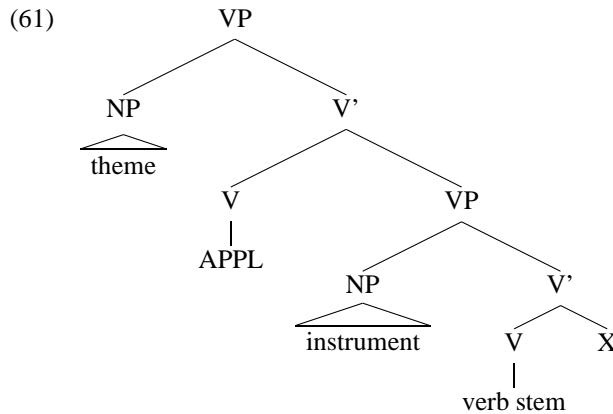

This structure can get the right order for the two complements but does not help in explaining why Samba speakers strongly dislike instrumental constructions with two postverbal complements. Moreover, with this structure it is even less expected that instrumentals would not be able to be object-marked.

Other Bantu languages such as Kinyarwanda and Haya allow non-extracted instrumentals, as shown in (62).

- (62) a. Umugoré a- ra- na- ha- ki- zi- ba- ku- n-  
 1woman SM1- FOC- ALSO- OM.LOC- OM7- OM10- OM2- OM2S- OM1S-  
 someesheesherereza  
 read.CAUS.CAUS.APPL.APPL  
 ‘The woman is also making us read it (book) with them (glasses) to you  
 for me there (in the house).’ (Loc > DO > Inst > Causee >  
 Goal > Beneficiary)  
 [Kinyarwanda, Beaudoin-Lietz et al. 2004:183]
- b. Tu- lika- gi- mu- ba- chumbilila- mu.  
 SM2P- RMF- OM9- OM1- OM2- cook.APPL.APPL- OM18  
 ‘We will (in the far remote future) cook him in it on their behalf.’  
 (Inst > DO > IO > verb > LOC)  
 [Haya, Rubanza 1988:117]

Applicative constructions are also restricted for reason applicatives, which Samba does not have. The detailed structural properties of these marginal constructions are beyond the scope of this thesis.

## 4.4 Object agreement in other Bantu languages

I have argued for a Minimalist implementation of Agree based on Chomsky (2000, 2001) for Smbaa. In this section, I reconsider the way object-marking works in Haya and Swahili to see if the same analysis can account for object marking in all three languages. I conclude that with some modifications it can. Although the modifications are rather far-reaching, it is shown that other accounts, in terms of Agree for one language and pronominal incorporation/clitic insertion for the other, run into equal or bigger problems.

### 4.4.1 Haya object marking

As shown in chapter 3, in Haya either object can trigger object marking. However, the basic word order and the order of morphemes are the same as in Smbaa. Moreover, as will be shown in the next chapter, the Person Case Constraint effects work in the same way in the two languages. As discussed in section 3.4.3, there are differences between Haya and Smbaa double object constructions for passivization and for object marking. In Haya, the direct object can be marked when the indirect object is not marked, as shown in (63a). This is ungrammatical in Smbaa, as shown in (63b).

- (63) a. N- ka- ki- ha omwana.  
SM1S- PAST3- OM7- give 1child  
'I gave it to the child.' [Haya]
- b. \* N- za- chi- nka ng'wana.  
SM1S- PERF.DJ- OM7- give 1child  
Int: 'I gave it to the child.' [Smbaa]

There are no differences for c-command relations between objects in Smbaa and Haya, which suggests that the underlying structures are the same. In Haya, the indirect object c-commands the direct object but not the other way round. This is shown in (64). In (64a), the indirect object c-commands the direct object and the pronoun inside the direct object receives a variable reading. As shown in (64b), in this construction the two objects cannot appear in the DO IO order, which, as shown in chapter 3, is generally grammatical in Haya. With a quantifier in the direct object DP the sentence is judged ungrammatical, as shown in (64c).

- (64) a. N- ka- shomera [buli mwandiki]<sub>i</sub> ekitabo kye<sub>i</sub>.  
SM1S- PAST3- read.APPL every 1writer 7book 7POSS1  
'I read every writer his book.'
- b. \* N- ka- shomera ekitabo kye buli mwandiki.  
SM1S- PAST3- read.APPL 7book 7POSS1 every 1writer  
Int: 'I read every writer his book.'
- c. \* N- ka- shomera omwandiki wakyo buli kitabo  
SM1S- PAST3- read.APPL 1writer 1ASS.PRO7 every 7book  
Int: 'I read its writer every book.' [Haya]

The word order preferences in double object constructions are also not affected by object marking. The preferred word order is still V IO DO. The sentence in (65a) shows the unmarked word order with object marking for the indirect object, which was produced spontaneously; the order in (65b) is judged as marked and not used. In (65c) and (65d) both objects are object-marked, again the order DO IO is preferred. With object marking only for the direct object, the word order IO DO is acceptable as shown in (65e), while the order DO IO, as shown in (65f), is judged as degraded.

- (65) a. N- ka- mu- ha omwana ekitabo.  
SM1S- PAST3- OM1- give 1child 7book  
'I gave the child a book.' (preferred word order)
- b. N- ka- mu- ha ekitabo omwana.  
SM1S- PAST3- OM1- give 7book 1child  
'I gave the child a book.' (marked word order)
- c. N- ka- ki- mu- ha omwana ekitabo.  
SM1S- PAST3- OM7- OM1- give 1child 7book  
'I gave the child a book.' (preferred word order)
- d. N- ka- ki- mu- ha ekitabo omwana.  
SM1S- PAST3- OM7- textscom1- give 7book 1child  
'I gave the child a book.' (marked word order)
- e. N- ka- ki- ha omwana ekitabo.  
SM1S- PAST3- OM7- give 1child 7book  
'I gave the child a book.' (preferred word order)
- f. (?) N- ka- ki- ha ekitabo omwana.  
SM1S- PAST3- OM7- give 7book 1child  
'I gave the child a book.' (marked word order) [Haya]

The order of the objects markers in Haya cannot be modified, just like in Sambia. If the object marker corresponding to the direct object (in (66) this is *-ki-*, class 7) appears closer to the verb stem than the object marker for the indirect object *-mu-*, class 1, the sentence is ungrammatical.

- (66) \* N- ka- mu- ki- ha omwana ekitabo.  
SM1S- PAST3- OM1- OM7- give 1child 7book  
Int: 'I gave the child a book.' [Haya]

The c-command relations indicate that Agree applies to the same structural configuration in Haya as in Sambia, although there are no DPs in Haya which trigger obligatory agreement, and Haya objects behave symmetrically on the surface, as discussed in section 3.4.3. The fundamental difference is that Haya allows Agree to pass over the indirect object as in (65e). Consider the structure in (67) where the Probe is checked by the direct object, which as the c-command data and basic word order facts show, is lower than the indirect object. This is problematic for the theory of Agree put forward so far because Agree skips the indirect object and agrees with the direct object.

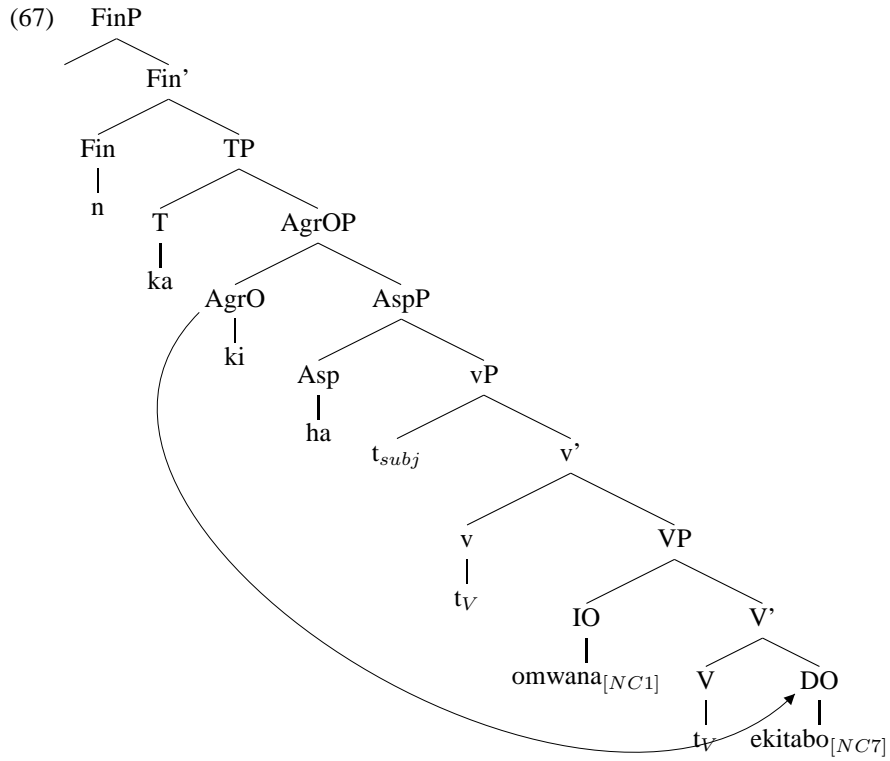

Based on such data one may be tempted to revert to the pronominal analysis of object marking in Haya. However, the same data would also be problematic for analyses in terms of pronominal incorporation because incorporation is subject to the far stricter locality conditions of the Head Movement Constraint following Travis (1984). This is because incorporation involves head movement (Baker 1988a).

Let us consider the structure which pronominal incorporation would involve for Haya, starting with incorporation of the direct object only. The incorporation analysis works fine in this case, as shown in (68). The pronoun *-ki-* is merged as the sister of V, as the direct object. It head-moves to V and adjoins to the left of V, following Kayne (1994), forming a new head V, which moves to v and finally to Asp. The co-indexed lexical “object” *ekitabo* is adjoined to CP in a right-dislocated position.

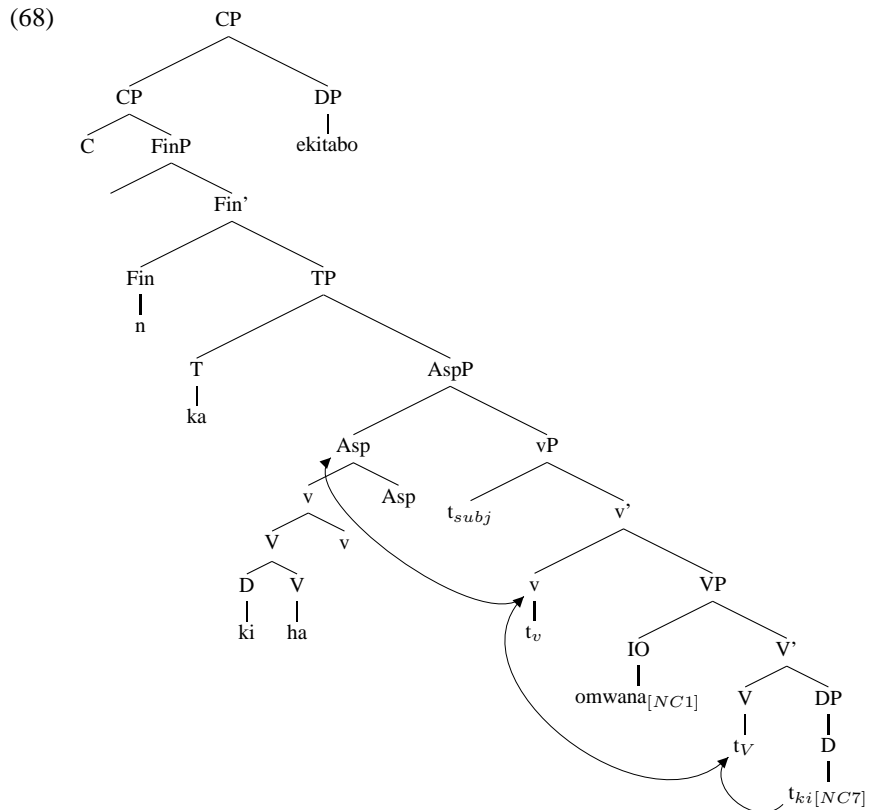

For object-marking an indirect object, the pronominal incorporation analysis is slightly more problematic. The indirect object cannot adjoin to V as it would have to lower to do so. Lowering is ruled out under the structure preservation condition applied to head movement. This requires head movement to leave a well-formed trace, which means a trace which is c-commanded by its antecedent (Roberts 2003). A head which lowers could never c-command its antecedent. Instead the pronoun in the indirect object position moves up to v. In order to get the right order of morphemes, V moves to v first and *mu* subsequently moves to v and left-adjoins to the it. This is shown in (69).

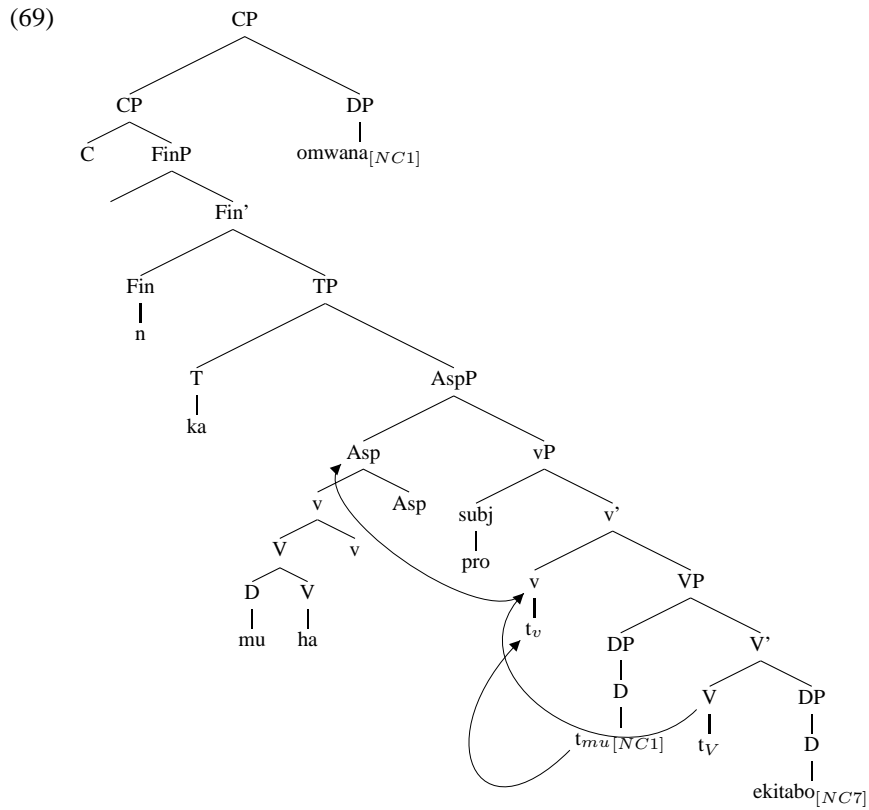

However, if both pronouns incorporate it becomes impossible to derive the right order of morphemes via head movement. The only possible derivation would put the direct object closer to the verb stem. This problem would extend to Sambia also, as well as any other Bantu language with multiple object markers where the indirect object is closest to the stem and which has the same c-command relations between the two objects are Sambia and Haya. The desired structure is shown in (70).

(70)

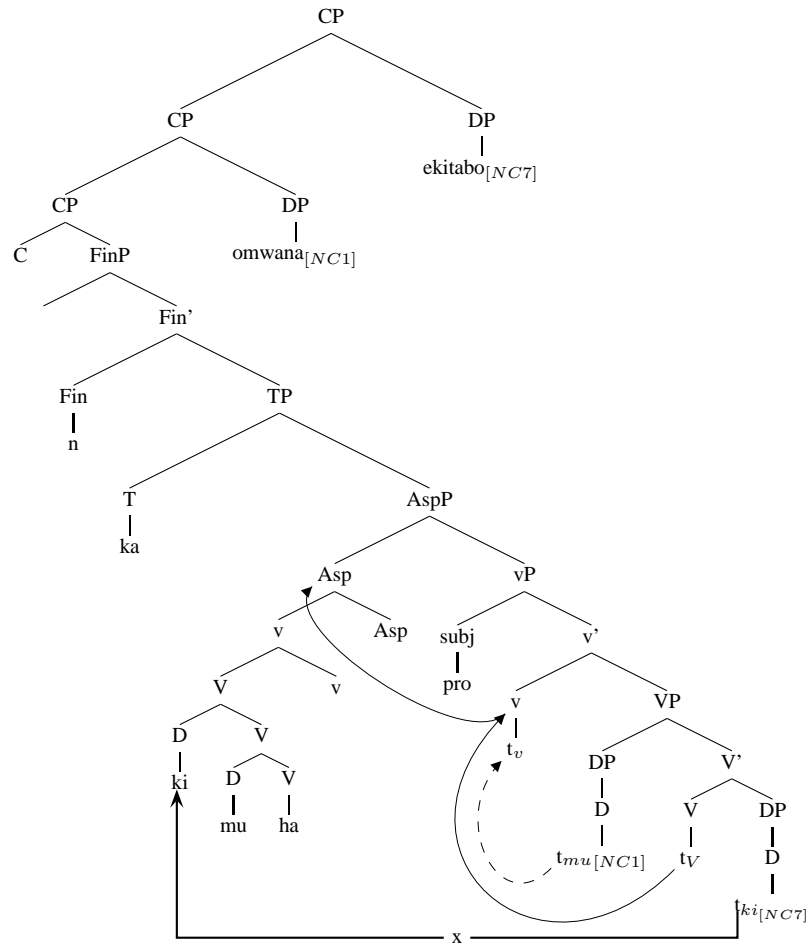

The only possible derivation which would get the right morpheme order would require lowering. Namely, if the indirect object *mu* lowered to V, and the direct object *ki* subsequently raised to V and left-adjoined to the complex head IO-V. As stated above, this would violate the conditions on proper head movement. Any sentences with more than two object markers would create even bigger problems. This means that the head movement analysis cannot account for the order of multiple object markers in any Bantu language, in any way which would not consistently violate the Head Movement Constraint.

The third potential analysis is in terms of object markers as clitics. This is shown in (71). Here the object marker is treated as DP, in the same way as a free pronoun, which moves to spec,vP. The structure we have argued for elsewhere, is slightly modified here. The verb raises to v rather than Asp since v is generally associated with checking object case and treated as a site where clitics are merged for Romance (Torrego 1998). The idea that the tense marker forms a unit with the subject marker to the exclusion of

the verb has been argued for by a number of Bantuists including Barrett-Keach (1986) and Myers (1987, 1990), for languages such as Swahili and Shona. There are several unresolved issues with this approach though. If one DP can move to this position, why can a lexical DP or a full pronoun not move here? How is the strict ordering of the object markers and their mirroring of syntactic structure explained? And why does the pronoun move? Why can it not appear in its base position?

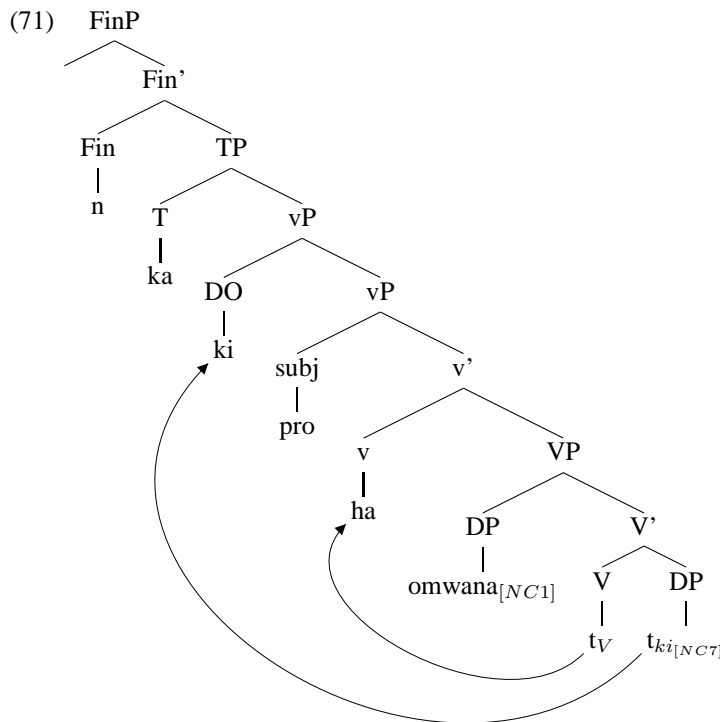

If the mirroring of the word order of the full DPs by the order of the object markers, is explained by attraction by an unchecked case feature on v, this analysis again cannot account for the Haya data either, because Attract would select the closest clitic in the same way as agreement. Even base-generating the clitic in its surface position would run into the same problem. The only potential solution would be if the attracting head had a special case feature for the direct object. This would not work so well if the head is simply v, but a dedicated functional projection (for each clitic) could potentially have a direct object feature.

Recall the concept of Equidistance from (Chomsky 2000), as defined in (10). Under this definition, patterns such as (67) would be predicted to be grammatical. Both objects are part of the VP and therefore equidistant to any Probe. Passivization in Haya works similarly to object marking, as discussed in section 3.4.3, either object in a double object construction can be passivized in Haya. An example of the symmetric passive in Haya is shown in (72).

- (72) a. N- ka- ebwa ekitabō.  
 SM1S- PAST3- give.PASS 7book  
 'I was given a/the book.'
- b. Ekitabō ki- ka- ebwa inye.  
 7book SM7- PAST3- give.PASS me  
 'The book was given (to) me.'
- [Haya]

As discussed in chapter 3, Haya also allows either order of the two complements. However, as in Haya, the unmarked word order is V IO DO, and in that way it is no different from Swahili where only the indirect object can be object-marked or passivized. We are left with a puzzle. In Haya, although there are clear c-command relations and a clear word order and an unchangeable morpheme order, processes such as passivization and object marking can apparently see both arguments inside VP. One solution to this, albeit an undesirable one in terms of economy and elegance, would be to reintroduce Equidistance as a parameter for the languages which display such patterns. Equidistance can account for the Haya passive as shown in (73), corresponding to (100b).

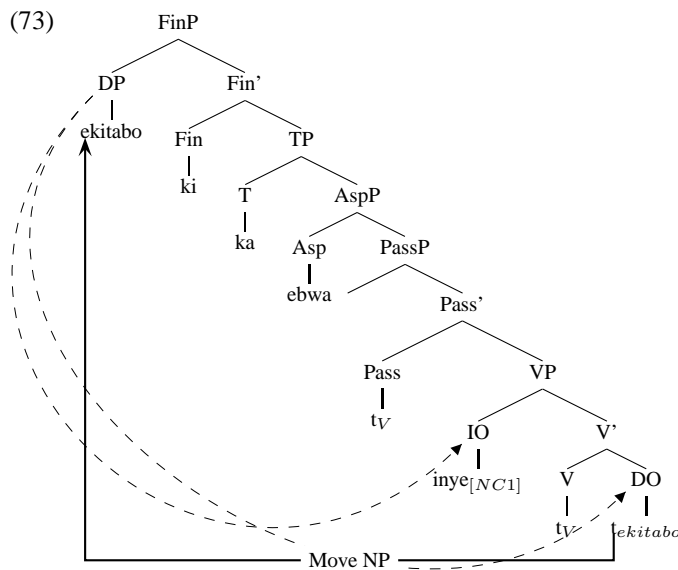

Equidistance is theoretically undesirable, as a sort of stipulated exception to minimality conditions. Equidistance is also no longer part of the current Minimalist theory of Agree, since Chomsky (2001), because, as was argued for Samba, the two complements in a double object construction are clearly not equidistant, unlike in Haya. The data from Samba show that as least as a general condition on Agree, Equidistance is unnecessary. Parameterizing Equidistance can allow us to account for both types of system.

#### 4.4.2 Swahili

Turning to object agreement in Swahili, recall that animate direct objects in simple transitives and indirect objects in ditransitives need to be object-marked. This is shown in (74a) for a monotransitive and in (74b) for a ditransitive. In Swahili, object marking is only possible for one object in a clause. However, as in Smbaa, a double object construction is grammatical where only the indirect object (in this case *mtoto*) is object-marked, irrespective of the feature structure of the direct object, as shown in (74c). Note that, in Swahili, most kinship terms are in class 9 grammatically and the possessive tends to agree with that class, but verbal and adjectival agreement for such nouns are always with class 1/2.

- (74) a. \* Stella a- li- ona mtoto wake.  
 1Stella SM1- PAST- see 1child 1her  
 Int: ‘Stella saw her child.’
- b. Stella a- li- m- pa mtoto kitabu pale.  
 1Stella SM1- PAST- OM1- give 1child 7book 16there  
 ‘Stella gave the child a book there.’
- c. Stella a- li- mw- onyesha mtoto mama yake.  
 1Stella SM1- PAST- OM1- show 1child 9mother 9his  
 ‘Stella showed the child his mother.’ [Swahili]

Swahili allows optional object marking of a direct object in a simple transitive clause, as shown in (75a) or a locative in an intransitive, as shown in (75b).

- (75) a. Stella a- li- ki- penda kitabu.  
 1Stella SM1- PAST- OM7- like 7book  
 ‘Stella liked the book.’
- b. Stella a- li- pa- fika mapema.  
 1Stella SM1- PAST- OM16- arrive early  
 ‘Stella arrived there early.’ [Swahili]

In section 4.3.3, c-command relations in Swahili were shown to be like those of Smbaa. As shown here, Swahili obeys the same restrictions on object marking as Smbaa, with a slightly different feature structure and an additional limit on the number of object markers to one. Considering the structure in (76), it looks as if the intervening DP blocks agreement with the lower DP in spite of the fact that its features are checked.

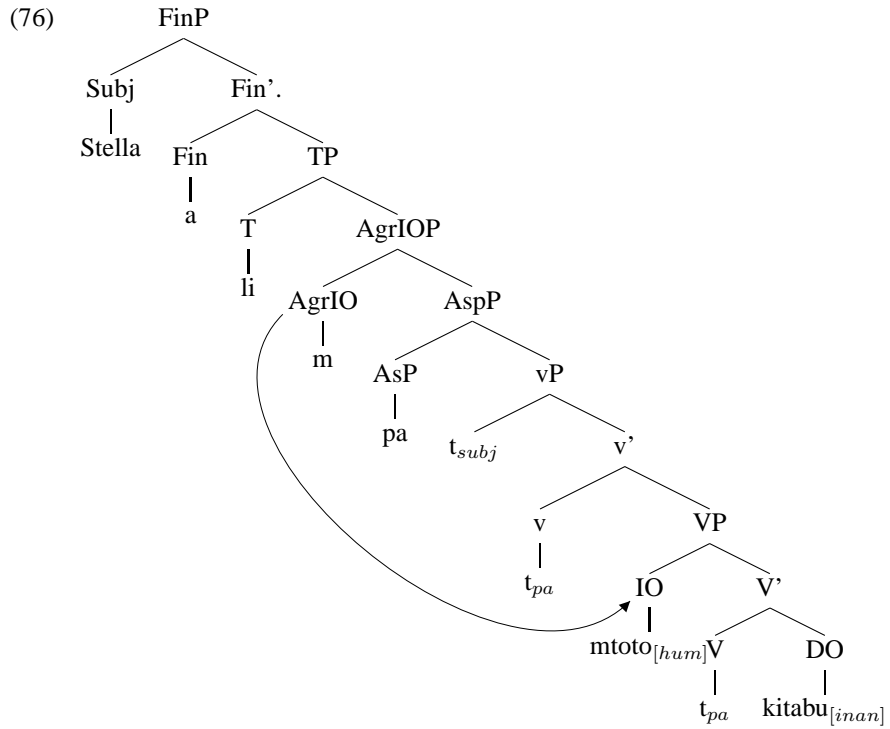

Since object marking is possible for direct objects and locatives, it would be somewhat counterintuitive to argue that Swahili never projects these as Agree heads. However, the pattern could be explained by invoking the Defective Intervention Constraint, as formulated in (14). Applied to a double object construction we would have the structure shown in (77), where the checked features of the IO block checking of the DO.

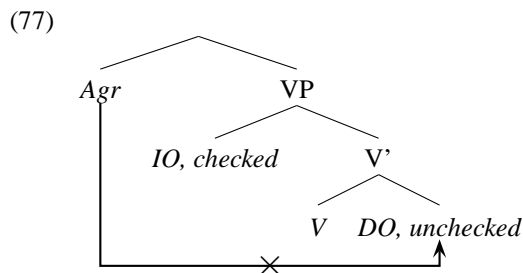

Removing conditions such as the DIC from the basic theory of Agree and parameterising them instead can account for the variation between the three languages, while allowing to account for the similarities between them in a unified system. Both conditions were independently justified with data from other languages. Samba has the

most elegant and simple Agree mechanism. Agree is simply determined by closest c-command.

## 4.5 Conclusions

In this chapter, I have argued that object marking in Sambiaa is an instance of Agree. Based on evidence from word order, I have argued that agreed-with objects stay in situ. I have shown that object agreement in Bantu is a relation between a verb and a DP, never a PP. I have shown that in Sambiaa, person agreement is no different from number and gender agreement with regard to movement, contra Baker (2008), but that person features differ from other  $\phi$ -features in terms of Agree. I have suggested that DPs in Bantu languages have non-active gender features, and that this derives the optionality of Agree for most types of objects.

Agree for a language like Sambiaa can be explained with a minimal theoretical apparatus, where locality is reduced to closest c-command and only Probes necessarily have active features and there is no zero morphology. Agree in Swahili, is subject to additional constraints on locality, namely the Defective Intervention Condition.

In spite of their differences in terms of the grammatical surface word orders, Sambiaa, Swahili and Haya have the same c-command relations and the same basic word order. I argue that the order of the complements in a double object construction reflects the underlying hierarchical structures of the constituents even after Agree. This order mirrors the order of Agree heads in all languages, making it plausible that the same process applies in all three languages.

The fact that either object in a double object construction can be object-marked in Haya remains problematic. However, I have shown that, unlike the pronominal incorporation analysis, an analysis in terms of Agree can account for the data, provided the concept of Equidistance is used. Because Equidistance effects are absent in languages such as Sambiaa and Haya, Equidistance was removed from the basic conceptualisation of Agree and demoted to a parameter on syntactic relations in symmetric languages such as Haya.

The next chapter looks at a specific type of cases of Agree with two objects: sentences with a direct object which is first or second person.



## CHAPTER 5

---

### The Person Case Constraint in Bantu

---

In chapters 3 and 4, Bantu languages with multiple object markers on a single verb were discussed, as were the special properties of pronouns with first or second person features. In this chapter, I discuss double object constructions where either one or both objects have first or second person features. Cross-linguistically, such constructions are problematic when the direct object has first or second person features. In languages with “weak” direct objects, a possibly universal constraint bans agreement with or cliticization of weak direct objects with first or second person features in a ditransitive constructions. Following Bonet (1994), this constraint is generally called the Person Case Constraint (PCC). In a number of languages, such a construction is only ungrammatical if the indirect object has third person features, while ditransitives where both objects have first or second person features are acceptable. The fact that agreement with one object depends on the features of the other object makes this constraint particularly problematic for syntactic theories of agreement based on a Probe-Goal relation.

The PCC effects are problematic for two reasons: they are sensitive to (morpho-) phonology and, more strikingly, they appear to show two elements in syntax which see each other although they are not connected in any feature checking relationship with each other.<sup>1</sup>

Beyond the Romance language family and Greek (Anagnostopoulou 2003), PCC effects have been discussed for a number of languages of North America from different language families. Like the Bantu languages, some of these languages inflect verbs for the  $\phi$ -features of their arguments. However, Bantu languages are strikingly different from some of the other languages with verbal object marking for multiple comple-

---

<sup>1</sup>In a number of Romance languages, there are constructions with full DPs which are only grammatical where the clitic-doubling version would violate the PCC. Rezac (2006) discusses this kind of data.

ments, because in Bantu the relevant morphemes are visibly separate morphemes with a full set of  $\phi$ -features, not portmanteau morphemes as in most of the languages for which object agreement has been discussed from a theoretical perspective, including Southern Tiwa, Kiowa and Mohawk (Adger and Harbour 2007; Baker 1996, 2008). There are also languages, such as Lakhota and Nahuatl which have object agreement morphology that is more similar morphologically to Bantu (Baker 1996, 2008). However, apparently most of these languages, with the exception of Lakhota (Haspelmath 2004:10) also ban person agreement with more than one object.<sup>2</sup>

Based on PCC-violation data, several syntacticians working on agreement have argued that a verb can only agree in person features with one object (Adger and Harbour 2007; Baker 2008). This is generally derived via a requirement for the object to move in order to agree and a missing functional feature for the PCC-violating object to check. A distinction is made between first and second person, on one hand, and third person, on the other hand, either in terms of having person features (Anagnostopoulou 2003), or in terms of locality (Adger and Harbour 2007; Baker 2008). However, in a typological study of languages which allow person marking on the verb for two objects, Gensler (2003) shows that this pattern is found in languages spoken across the globe with the exception of South America. Moreover, Bantu languages such as Sambia and Haya allow object marking for two objects with person features. Baker (2008) discusses such data and argues that the grammaticality is related to the agreement versus pronoun distinction. He suggests that the Person Case Constraint might serve as a test to distinguish syntactic agreement from pronominal object marking. His suggestion is that syntactic agreement always obeys the PCC while clitics may not. This analysis is based on the claim made with reference to Duranti (1979) that Haya violates the PCC while Sambia does not violate it.<sup>3</sup>

In this chapter, I introduce the constraint and the current theoretical approaches to it. I compare data from Haya and Sambia, showing that there are only minor differences between the two languages with respect to the PCC. In fact, Haya does obey the PCC and, as shown in this chapter, Haya obeys it slightly more strictly than Sambia. Finally, I discuss data from a range of Bantu languages and show the extent to which the patterns can be accommodated by a simple theory of agreement.

## 5.1 The Person Case Constraint

The PCC has received much attention in recent syntactic literature (Adger and Harbour 2007; Anagnostopoulou 2003; Nevins 2007; Rezac 2006). Bonet (1994) proposes the term PCC for this cross-linguistic restriction, which was previously known as the *me-lui* constraint for French.<sup>4</sup> Based on data from typologically diverse languages,

<sup>2</sup>The example from Lakhota in Haspelmath (2004) has a third person indirect object and a second person direct object, thus violating even the weak PCC, as defined in (4).

<sup>3</sup>Duranti (1979) does not use the term PCC. He discusses these effects in terms of the animacy-case-definiteness hierarchies.

<sup>4</sup>In Bonet (1991) this term, not PCC, is used for the constraint in a number of languages other than French.



- (3) Person Case Constraint (strong version): For weak pronouns in ditransitive constructions: the direct object has to be third person.

Bonet notes that there are languages which violate (3) (Bonet 1994:33). These include dialects of French and Catalan. To account for this, Bonet also proposes a weaker version of the constraint. The so-called weak version bans first or second person direct objects from co-occurring with third person indirect objects (Bonet 1994:40-1). An adjusted version of the constraint is shown in (4).

- (4) Person Case Constraint (weak version): For weak pronouns in ditransitive constructions: If there is a third person indirect object, the direct object has to be third person.

The key difference between the two versions of the constraint is that the weak version allows person agreement for two objects (when first and second person are treated as persons while third person is not, as in Adger and Harbour (2007); Baker (2008)). However, for the Romance languages it is not clear how robust the violations of the strong version of the PCC are (Ormazabal and Romero 2007). Adger and Harbour (2007) criticise the distinction between the weak and strong version as too arbitrary. In Bantu, as shown here, the data is very clear. The strong PCC is violated and the weak PCC is obeyed.

Aside from Bonet's definition, there have been other attempts to formulate the constraint. Rezac (2006:99), for example, defines the PCC as ruling out agreement with a first or second person pronoun in the presence of an intervenor, or the occurrence of such a pronoun<sup>7</sup>. He defines the relevant contexts as the environments where another DP intervenes between a first or second pronoun which needs to be assigned structural case or undergo Agree, and *v* (the assigner of case and locus of the Probe for Agree). For Rezac, Case assignment requires Agree. This definition rules out violations of the strong PCC. Because Bantu languages obey the weak PCC, rather than the strong version, Rezac's definition is too strict to account for the Bantu data. Ormazabal and Romero (2007) reformulate the PCC as a constraint on object marking based on animacy. This approach also does not work for the Bantu data, because there are clear differences between objects with first or second person features and other animates in double object constructions. I discuss their data in section 5.4. Bonet's generalizations about the PCC effects, particularly the weak PCC, fit the Bantu data better. I will adopt them here, using my own definitions, as stated in (3) and (4). It should be noted that any sentences which violate the weak PCC necessarily also violate the strong PCC. The strong PCC is needed to account for languages which do not allow combinations of first and second pronouns in ditransitive constructions.

In (5), the same effects are seen as in the French data.<sup>8</sup> With the acceptable combination of a third person accusative and a third person dative, both objects can be realised as clitics, as shown in (5a). If the direct object is first person, however, the

<sup>7</sup>Where the occurrence is ungrammatical, structural case is the problem. This allows for the exceptions for quirky case in Icelandic (Rezac 2006:100).

<sup>8</sup>Thanks to Camelia Constantinescu for providing the Romanian examples and discussion.



Baker (2008:98/99) claims that Smbaa does not allow first or second person direct objects in double object constructions. However, my own data is different. First and second person can co-occur as the two objects of a double object construction without any degradation of grammaticality, as shown in (7a) and (7b). In this sentence, the objects are expressed by object marking alone, as is typical for non-contrastively focussed pronouns, with the object function, in Smbaa. This means that Smbaa violates the strong version of the PCC. As (7b) also shows, there is also no requirement for the first person singular object marker to be immediately adjacent to the verb stem.

- (7) a. A- za- ku- ni- onyesha.  
SM1- PERF.DJ- OM2S- OM1S- show  
'He pointed you out to me.'
- b. A- za- ni- ku- onyesha.  
SM1- PERF.DJ- OM1S- OM2S- show  
'He pointed me out to you.' [Smbaa]

Both versions of the PCC allow cases, such as (8a) where the direct object (corresponding to the accusative-marked object in Romance languages) is third person, while the indirect object (corresponding to the dative marked object in Romance languages) is first person. The inverse of this configuration is ungrammatical, as shown in (8b).<sup>10</sup> Thus, Smbaa does obey the weak version of the PCC. To express a first person direct object in verbs with a third person benefactive goal ("indirect object"), the "indirect object" must appear inside a non-argument PP, as shown in (8c).<sup>11</sup>

- (8) a. A- za- m- ni- onyesha.  
SM1- PERF.DJ- OM1- OM1S- show  
'He pointed her/him out to me.'
- b. \* A- za- ni- mu- onyesha.  
SM1- PERF.DJ- OM1S- OM1- show  
Int: 'He pointed me out to her.'
- c. A- za- ni- onyesha kwakwe.  
SM1- PERF.DJ- OM1S- show 17ASSOC.POSS3S  
'He pointed me out to her.' [Smbaa]

In Smbaa, *iwe* 'you' cannot appear as a full pronoun in the direct object position, following the indirect object *Juma*, as shown in (9a). Like in Romanian, the first person pronoun requires doubling, as shown for Romanian in (9b) and (9c). In Smbaa, a full pronoun is only grammatical when it is doubled by an object marker. However, even in this case the construction is still ungrammatical if the first person pronoun is

<sup>10</sup>Duranti (1979), Hyman and Duranti (1982) and others treat object marking in terms of animacy hierarchies on morpheme orders, such hierarchies would also rule out this construction because the first person singular object marker is higher and therefore needs to be closer to the stem than the third person.

<sup>11</sup>Although in Bantu the argument structure of a verb is generally visible from its morphology, there is no overtly marked difference in the argument structure of the verb in (8a) and (8b), compared to the structure of the verb in (8c). However, the verb in (8c) is a simple transitive, not a ditransitive verb. This syntactic difference becomes clear with verbs such as *ighaa* 'send', as illustrated by the paradigm in (20).



However, in fact, for the strong version, Haya is more restricted than Sambiaa, by not allowing a reordering of first and second person singular, as shown in (11a) and (11b). Yet, both readings are possible. This is similar to what has been reported for some dialects of Catalan.

- (11) a. A- ka- ku- ndeetela.  
 SM1- PAST3- OM2S- OM1S.bring.APPL  
 ‘He brought you to me.’ or  
 ‘He brought me to you.’ [Haya, Duranti 1979:40]
- b. \*A- ka- n- ku- leetela.  
 SM1- PAST3- OM1S- OM2S- bring.APPL  
 Int: ‘He brought you to me.’ or  
 ‘He brought me to you.’ [Haya, Duranti 1979:40]

Thus, both languages pattern in essentially the same way for the Person Case Constraint. Both languages violate the strong version, while obeying the weak version. Recall that Bonet’s definition makes reference to “agreement”. However, her concept of agreement does not match that used in Baker (2008). Under my analysis of both languages as having agreement, Sambiaa and Haya are expected to have the same pattern. If the PCC is interpreted as applying to weak pronouns, this cannot be used as a test, because no differences would be expected between any Bantu languages with object marking.

In spite of the syntactic differences between the two languages, as discussed in chapters 3 and 4, they pattern essentially in the same way with respect to the PCC. We can establish that the weak PCC definition is the one which applies to the Bantu data, and that our system of agreement needs to allow for agreement with person with two objects.

### 5.3 PCC effects and the syntax of agreement

Baker (2008) tries to incorporate PCC effects into his theory of the syntax of agreement. In this system, Baker tries to unify verbal and adjectival agreement into one general theory. Most of the conditions Baker proposes are rather standard assumptions, the exception being the ability for agreement to be able to go upwards (if the Goal c-commands the Probe) or downwards (if the Probe c-commands the Goal). Those c-command relations are most standardly defined as the Probe c-commanding the Goal following Chomsky (2000, 2001). Baker’s deviation from more standard theories of agreement is not relevant here, as none of the cases discussed here involve upward Agree. Baker’s general conditions on agreement following Chomsky (2000) are listed below:

- Probe c-commands Goal OR Goal c-commands Probe
- no intervening XP with  $\phi$ -features
- Probe and Goal are inside same phase

- XP has active (unchecked) features

To these, Baker adds a condition on person agreement. This is supposed to account for the differences between verbs and adjectives. Verbs can agree in person but adjectives never do (Baker 2008).

- (12) Structural Condition on Person Agreement (Baker 2008): A functional category F can bear the features +1 or +2 if and only if a projection of F merges with a phrase that has that feature, and F is taken as the label of the resulting phrase.

This requires objects with person features to agree in order to be able to move, unlike other types of objects.

Baker (2008) proposes a structure for object agreement using an example from Swahili, as shown in (13).

- (13) Juma a- li- ni- ambia kwamba ...  
 1Juma SM1- PAST- OM1S- tell that  
 ‘Juma told me that ...’ [Swahili, Baker 2008:54]

Baker (2008:54) provides a syntactic structure for (13), using English words, which is shown in (14). This structure is conservative in terms of following standard assumptions about agreement, namely that T and  $v$  are the relevant functional projections, where T is the Probe for subject agreement and  $v$  is the Probe for object agreement. Baker (2008) follows the  $v$ P-internal subject hypothesis and moves the subject to spec,TP. There are several specifiers of  $v$ P, resulting in a configuration where both the subject and the object end up in a Spec-Head relationship with the agreeing head,  $v$ . Since the subject is base-generated above the final landing site of the object, no intervention effects are found, because  $v$  does not c-command the subject at any point in the derivation.

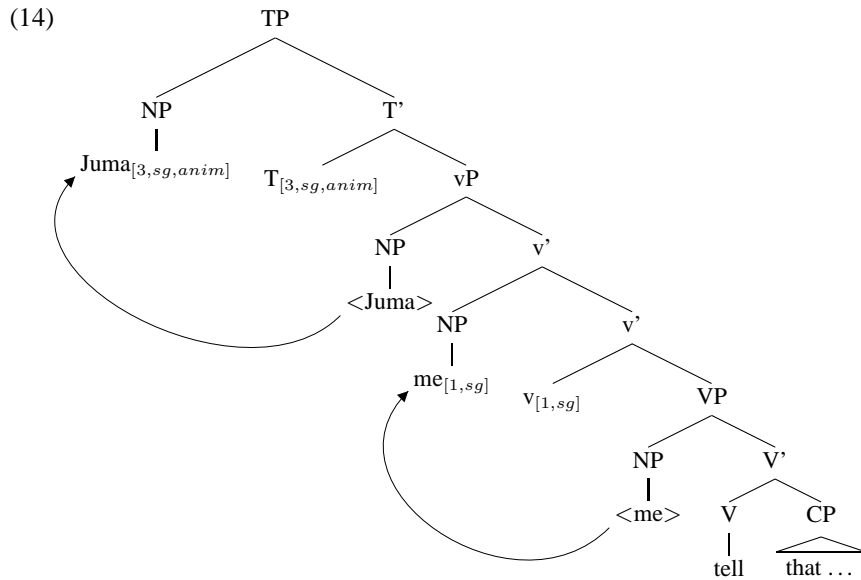

Baker argues that his Structural Condition on Person Agreement (12) predicts that no language can express full agreement with three arguments. Full agreement for Baker means person agreement. He analyses languages as having two and a half agreement, meaning that one object and the subject can agree in person with the verb but any other objects can only agree in number or gender. But as was shown in chapter 3, this does not hold for Sambia, nor for Haya, as shown in (15a) and (15b). In both examples, the subject is third person. Although Baker lumps the three arguments together, the person features of the subject do not affect the patterns for object marking in Bantu<sup>12</sup>. However, it is clear that he is ruling out agreement with two objects in person, not agreement in person with one object and the subject, because the latter pattern is well-established as grammatical cross-linguistically. Since there are only two persons for participants, it would be hard to construct any example where this is not the case, but the fact that subjects can agree in person in Bantu is not disputed. Crucially, the verb shows person agreement for each object in both languages.

- (15) a. A- za- ku- ni- onyesha.  
 SM1- PERF.DJ- OM2S- OM1S- show  
 'He pointed you out to me' [Sambia]
- b. A- ka- ku- ndeetela.  
 SM1- PAST3- OM2S- OM1S.bring.APPL  
 'He brought you to me.' [Haya]

Other approaches to PCC effects, such as Anagnostopoulou (2003) and Adger and Harbour (2007) build a ban on person agreement with two objects into the feature

<sup>12</sup>But see Béjar and Rezac (2009) where languages are discussed in which the feature structure of the subject and the object affect which argument will agree.

structure of the Goal or the Probe. Neither of those can deal with the strong PCC violation data. Having shown that Baker's restriction on person agreement incorrectly rules out (15a), I will discuss the restrictions on person agreement in Smbaa and related languages in more details.

## 5.4 The PCC and object marking across Bantu

Turning to the possible syntactic derivations of the patterns found in Smbaa, consider the examples in (16).

- (16) a. Stella a- za- m- ni- ighaiya.  
 1Stella SM1- PERF.DJ- OM1- OM1S- send.APPL  
 'Stella sent him to me.' (no PCC violation)
- b. \* Stella a- za- ni- mw- ighaiya.  
 1Stella SM1- PERF.DJ- OM1S- OM1- send.APPL  
 Int: 'Stella sent me to him.' (weak PCC violation)
- c. Stella a- za- ku- ni- ighaiya.  
 1Stella SM1S- PERF.DJ- OM2S- OM1S- send.APPL  
 'Stella sent you to me.' (strong PCC violation) [Smbaa]

The grammatical construction, in (16a), with a first person indirect object, has the structure in (17), where the dotted arrow stands for Agree, rather than Move. According to Baker (2008), this configuration is generally acceptable in languages which allow agreement with more than one object.

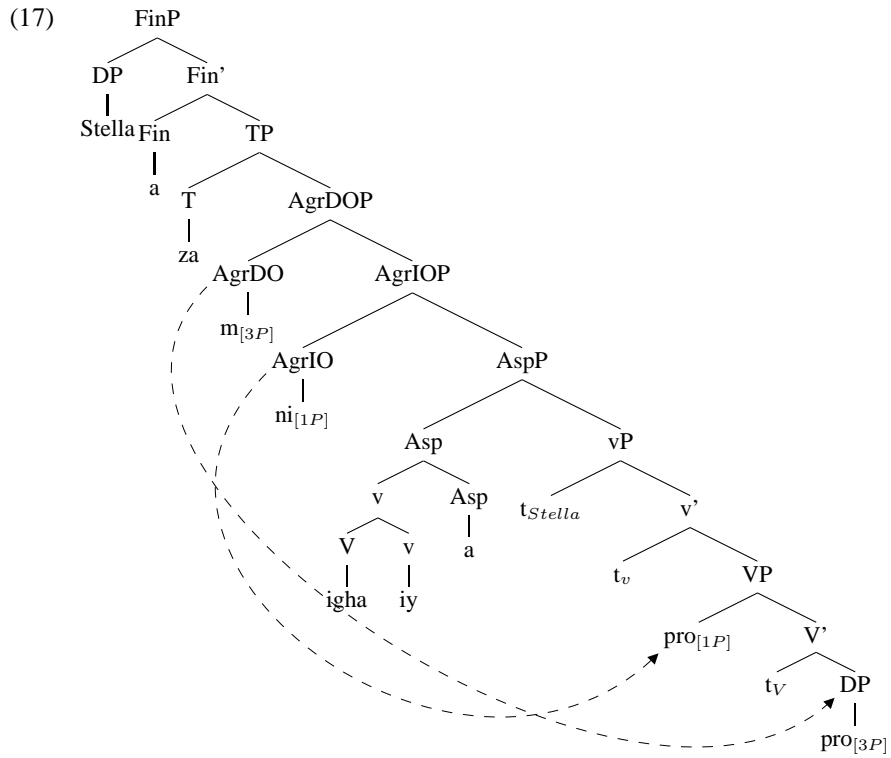

The ungrammatical construction, in (16b), with a third person indirect object, has the structure in (18).

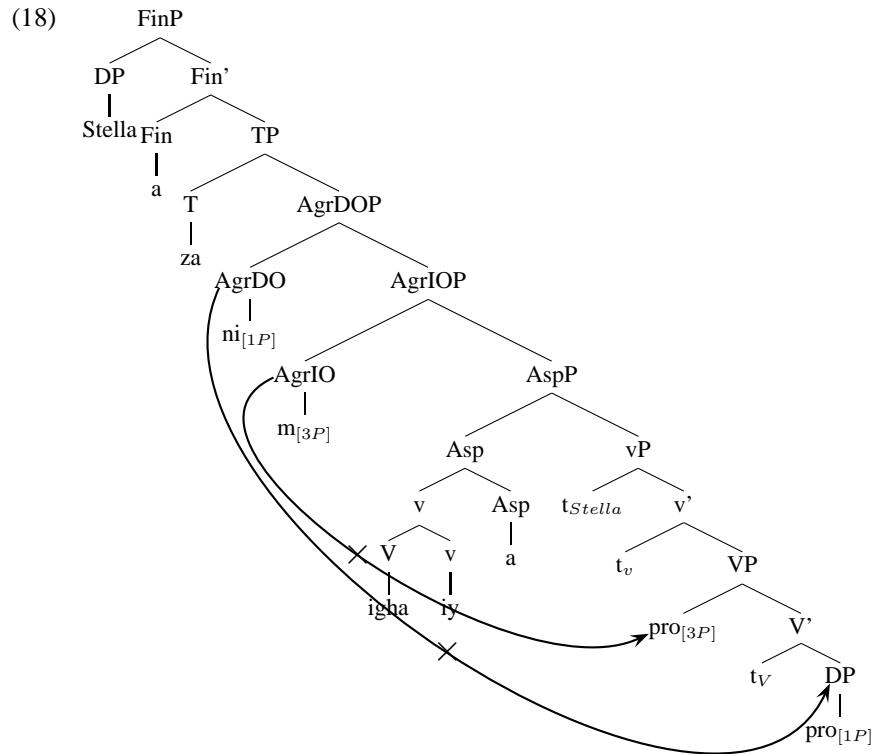

The grammatical construction with only first or second person objects, shown in (16b), has the structure in (19).

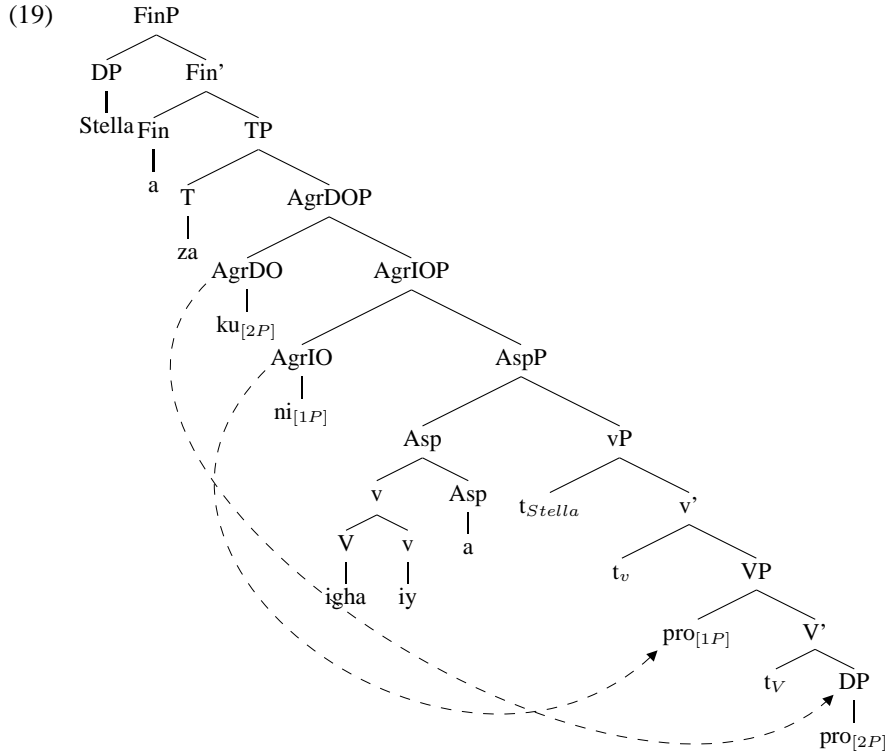

This makes it appear as if third person agreement of the indirect object blocks first person agreement of the direct object. This would, furthermore, require that agreed-with features remain visible to syntax.

However, when looking at more verb types in Sambia, the difference between Sambia and the Romance languages become apparent. In Bantu, unlike in Romance languages, the PCC does not apply to strong/weak pronouns but to a particular syntactic configuration. To avoid a PCC violation in Sambia, the goal must be expressed as a prepositional phrase, and thus be in a configuration which is invisible to agreement and the verbal argument structure. Furthermore, the verb must be in the appropriate form, without the applicative suffix, as shown in (20a). With the applicative suffix the sentence becomes ungrammatical, as shown in (20b). What would be the equivalent of the Romanian, Spanish or Catalan constructions, is ungrammatical in Sambia. A grammatical example from Romanian is shown in (20c) with a proper name for the direct object. The corresponding sentence is ungrammatical in Sambia with the relevant reading, as shown in (20d). However, with the reading where *Juma* is the direct object, the PCC is not violated and the construction is acceptable. The PCC does not rule out (20d), since there is no weak third person object.

- (20) a. N-    za-    ku-    ighaa kwa    Juma.  
           SM1S- PERF.DJ- OM2S- send 18ASSOC 1Juma  
           ‘I sent you to Juma.’ [Sambia]

- b. \* N- za- ku- ighaiya kwa Juma  
SM1S- PERF.DJ- OM2S- send.APPL 17ASSOC 1Juma  
Int: 'I sent you to Juma.' [Sambaa]
- c. M- a prezentat Mariei.  
me.DAT has.3S introduced Maria.DAT  
'S/he has introduced me to Mary.' [Romanian]
- d. N- za- ku- ighaiya Juma.  
SM1S- PERF.DJ- OM2S- send.APPL 1Juma  
\* 'I sent you to Juma.'  
✓ 'I sent Juma to you.' [Sambaa]

Without the applicative suffix and with a preposition, a third person goal can also be expressed in Haya. This is shown in (21) which is the equivalent to (10).

- (21) Ba- ka- ndeeta omwe.  
SM2- PAST3- OM1S.bring LOC.POSS 1  
'They brought me to him.' [Haya]

This means that the PCC is not just a restriction on weak objects but on double object constructions in Sambaa and Haya. In fact, even less closely related languages without object marking display this effect. The PCC effects also appear in Limbum, a Grassfields Bantoid language of Cameroon, which has double object constructions (DOCs) and dative constructions. As shown in (22a), a second person indirect object can be expressed in a DOC. If the second person object is the indirect object, the construction is ungrammatical, as shown in (22b).<sup>13</sup>

- (22) a. M̃ be dungshi wè ye.  
I FUT1 show you him  
'I will show him (to) you.'
- b. \* M̃ be dungshi ye wè  
I FUT1 show him you  
Int: 'I will show you to him.' [Limbum]

To express the proposition intended in (22b), a dative construction, with the preposition *nè*, must be used, as shown in (23a). This construction is freely available for the other meaning expressed by (22a), as shown in (23b). This is parallel to the constructions used to circumvent PCC violations in Sambaa, shown in (20a) and (8c) above.

- (23) a. M̃ be dungshi wè nè ye.  
I FUT1 show you to him  
'I will show you to him.'
- b. M̃ be dungshi ye nè wè.  
I FUT1 show him to you  
'I will show him to you.' [Limbum]

<sup>13</sup>Thanks to Francis Ndi for providing this data.

This is surprising, since in Limbum these are all full DP objects not clitics or agreement markers, as can be shown by the word order effects in (24). The indirect object appears immediately after the verb, as shown in (24a). Moving the direct object into this position is ungrammatical, as shown in (24b). However, if the pronoun is used with the preposition *nè*, the direct object (with a full lexical item or a pronoun) intervenes between it and the verb as shown in (24c).

- (24) a. E sang mè ngwà.  
           he send me book  
           ‘He sent me a book.’  
       b. \*E sang ngwà mè  
           he send book me  
           Int: ‘He sent me a book.’  
       c. E sang ngwà nè mè.  
           he send book to me  
           ‘He sent a book to me.’
- [Limbum]

In Limbum a first person object pronoun<sup>14</sup> must appear in the immediate post verbal position, or as the complement of *nè*. This is interesting since this is the same immediate postverbal position effect found with slight variations across the Bantu family. The indirect object must appear in this position in languages like Sambaa as well (as discussed in chapter 6). Moreover, it mirrors the order of the object markers in Bantu. Again, this shows that the PCC effect is not related to the syntactic status of pronominal elements, since the patterns found with full objects are the same as those of agreement markers across Bantu.

As I have shown in this section for a number of typologically very different Bantu languages, and the Bantoid language Limbum, violations of the PCC can only be avoided by reducing the valency of a ditransitive verb in Bantu, where the goal argument is demoted to a prepositional phrase.

PCC effects are observed more widely in Bantu, as they can be shown to also apply to languages with only one object marker. An example of that comes from Nyaturu (Rimi).<sup>15</sup> The Nyaturu data related to PCC effects is also discussed in Nevins (2007) and Ormazabal and Romero (2007). According to Hualde (1989), Nyaturu object-marked animate objects must be definite, while unmarked objects cannot be definite (Hualde 1989; Woolford 2000).<sup>16</sup> This causes problems in double object constructions. As shown in (25a), a double object construction with one indefinite animate object is grammatical (note that the indirect object is the one object-marked). If both complements are definite animates the construction becomes ungrammatical, as shown in (25b). To rescue the construction, the second argument needs to be demoted to a prepositional phrase while valency of the verb stem is changed from a three-place

<sup>14</sup>There is no overt case marking on pronouns, with subjects, indirect objects and direct objects having the same form.

<sup>15</sup>More general facts about Nyaturu object marking are discussed in chapter 3.

<sup>16</sup>Woolford explains this with a requirement of definite objects to move out of the VP, following Diesing (1992).

predicate to an applicative-less two-place predicate as shown in (25c). The grammatical and ungrammatical examples in (25a) and (25b) are both applicative verbs.

- (25) a. N- a- va- eteaa anca mūhumba.  
SM1S- TNS- OM2- bring.APPL 2girl 1boy  
'I brought the girls a boy.' [Nyaturu, Woolford 2000:108]
- b. \*N- a- va- tūmiaa alimu Yohanna  
SM1S- TNS- OM2- send.APPL 2teacher 1Yohanna  
Int: 'I sent the teachers Yohanna.' [Nyaturu, Woolford 2000:108]
- c. N- a- mū- tōmaa Yohanna kō alimu.  
SM1S- TNS- OM1- send 1Yohanna for 2teacher  
'I sent Yohanna to the teachers.' [Nyaturu, Woolford 2000:108]

The same pattern is observed with an actual PCC violation in (26a), which is repaired with the same structure as shown in (26b).

- (26) a. \*N- a- mū- eteaa mūnca veve  
SM1S- TNS- OM1- bring.APPL 1girl you  
Int: 'I brought the girl you' [Nyaturu, Woolford 2000:110]
- b. N- a- kō- etaa veve kō mūnca.  
SM1S- TNS- OM2S- bring you for 1girl  
'I brought you for the girl.' [Nyaturu, Woolford 2000:108]

Ormazabal and Romero (2007) discuss the Nyaturu data above, arguing that the PCC effects are due to a more general restriction, which they call the object agreement parameter. However, PCC effects are different from general animacy effects in most Bantu languages. In Sambiaa, combinations of two objects which both require object marking are grammatical with one object marker. The same holds for Swahili, as shown in section 4.4.2, and by examples such as (27a), Swahili allows sentences with one object marker but two objects both having the features that trigger obligatory object marking. Like Sambiaa, Swahili does not allow double object constructions that involve a direct object with first or second person features. These would not violate the PCC since they involve only one clitic. Moreover, like Sambiaa, Swahili allows a first or second person direct object with a first or second person indirect object. This is shown in (27c) for a second person direct object and in (27d) for a first person direct object.

- (27) a. N- li- ku- onyesha Juma.  
SM1S- PAST- OM2S- show 1Juma  
✓ 'I showed Juma to you.'  
\* 'I showed you to Juma.'
- b. \*Ni- li- mw- onyesha Juma wewe.  
SM1S- PAST- OM1- show 1Juma you  
Int: 'I showed Juma to you.'

- c. A- li- ni- onyesha wewe.  
 SM1S- PAST- OM1S- show you  
 ‘He showed you to me.’
- d. A- li- ku- onyesha mimi.  
 SM1S- PAST- OM1S- show me  
 ‘He showed me to you.’ [Swahili]

The Swahili and Limbum data show that PCC effects in Bantu are independent of object marking. Languages with one object marker pattern similarly to those with several, while languages without object markers show the same effects as those which have object marking. Interestingly, in Bantu, both weak pronouns and lexical DPs display PCC effects. Furthermore, PCC effects in Bantu cannot be reduced to animacy effects in the way suggested by Ormazabal and Romero (2007).

## 5.5 Conclusions

Verbal agreement with person features is possible for more than one object in Bantu. None of the languages discussed here obey the strong PCC. However, all languages considered here obey the weak version. The PCC effects observed in Bantu are robust. Apart from the shared patterns, no inter-speaker variation was found for morpheme orders. This is evidence in support of Bonet’s two versions (Bonet 1991, 1994). Moreover, the fact that weak PCC effects are found in languages as diverse as Sambia and dialects of Catalan and French lends credibility to the weak PCC as a cross-linguistic constraint.

There is no evidence that objects with person features require movement in Bantu. However, person features are different from other  $\phi$ -feature bundles in Bantu languages in terms of triggering grammaticality violations. In languages like Sambia and Swahili, most types of objects which require object marking in simple transitive clauses do not require object marking if they appear as the direct object of a ditransitive verb, but first and second person pronouns trigger violations in this kind of configuration. However, even for person features, being inside a prepositional phrase blocks any agreement violations. These facts show that the PCC is clearly syntactic in Bantu, because it is not sensitive to phonological strength.

The fact that Haya does not require agreement for first or second person in monotransitives but requires it in ditransitives is confounding. More problematic is the fact that an Agree relation between a Probe and a Goal with a third person feature blocks a subsequent Agree relation between a Probe and a Goal with a first or second person feature. There is no elegant solution to this at this point in time.

Another special class for object agreement patterns are *wh*-elements. The next chapter looks at the agreement patterns with objects in *wh*-questions, relative clauses and clefts across Sambia, Swahili and Haya.

## CHAPTER 6

---

### Object marking in *wh*-environments

---

In chapters 3 and 4 of this thesis, I discuss object marking patterns in declarative clauses, showing that object marking in Smbaa is optional for most semantic classes of objects and how these may be accounted for in terms of agreement. However, *wh*-questions display a different pattern. In Smbaa, object marking is generally not optional in *wh*-questions.

Object marking patterns in *wh*-questions are different from those in propositional main clauses in a number of other Bantu languages (Bresnan and Mchombo 1987). Across Bantu, there is also variation for object marking in relative clauses, with some languages requiring it, some allowing it and others banning it (Henderson 2006b; Marten et al. 2007). In the Bantu literature, these differences have been attributed to differences regarding the syntactic status of the object marker (Bresnan and Mchombo 1987; Duranti 1979; Henderson 2006b).

Object markers which are pronominal are predicted to be ungrammatical when doubling a *wh*-element which appears in situ. This is because a pronominal object marker should not be able to double a local argument. In the case of *wh*-elements, right-dislocation should be impossible. This is because right-dislocated elements are generally considered to be topical, whereas *wh*-elements are focal. Focus and topicality are generally treated as mutually exclusive properties. It follows from that, that a *wh*-element should not be able to be right-dislocated. Thus, if one analyses object-marked objects as right-dislocated for a particular language, like Bresnan and Mchombo (1987) do for Chichewa, one would predict object marking of *wh*-elements to be ungrammatical in that language. Whereas in languages where object marking is agreement, no such effect is expected.

Bresnan and Mchombo (1987) use object marking in *wh*-questions as a diagnostic for the pronoun/agreement marker distinction. They argue that Swahili, which allows

a *wh*-object to be object-marked, has object agreement; while Chichewa, which does not allow a *wh*-object to be object-marked, has pronominal object marking. Duranti (1979) similarly argues that Haya object marking is pronominal because it is ungrammatical in questions. However, if one looks at languages like Swahili more carefully, a somewhat different pattern emerges. Object marking patterns in *wh*-environments cannot always be predicted based on the object marking patterns found in other syntactic environments, neither for Swahili nor for Bantu languages in general. It can also be observed that there are differences between the various types of *wh*-environments which cannot be predicted based on their morphological similarities. For example, cleft questions and relative clauses in Smbaa have different object marking patterns, in spite of showing the same kind of morphological marking. Bresnan and Mchombo (1987) do not distinguish between different types of *wh*-objects. They also do not examine cleft questions, or the differences between d-linked and non-d-linked questions. Lastly, they do not look for parallels or differences between questions and relative clauses with regard to object marking patterns in Bantu.

Henderson (2006b) makes a connection between object marking in relative clauses and doubling in non-relative clauses. He argues that Bantu languages which allow doubling have object agreement, while Bantu languages which do not allow it have pronominal object marking. With regards to doubling he uses a similar test to the test for right-dislocation used in chapter 3, namely the ability of an object-marked object to appear before a temporal adverbial. Using this kind of doubling as a diagnostic, he concludes that Chichewa has object agreement, rather than pronominal object marking as argued in Bresnan and Mchombo (1987). Amongst the languages that Henderson discusses, the ones which allow doubling also allow object marking in relative clauses while the languages which do not allow doubling do not. Based on this, Henderson argues that these properties are related. It will be shown below that this generalization does not hold for Haya.

Beyond the implication for the agreement/pronoun distinction, object marking in questions may give us more insights into the syntax of agreement as well as the syntax of questions in Smbaa. In many Bantu languages, *wh*-elements appear in a particular syntactic position. This position is commonly referred to as the IAV position (immediate postverbal position), which is argued to be the focus position in many Bantu languages (Buell 2009b; Hyman and Polinsky 2006; Hyman and Watters 1984; Ndayiragije 1999; Sabel and Zeller 2006; van der Wal 2006; Watters 1979). This position is argued to be below TP. In the Bantu languages which have a conjoint/disjoint distinction, the distribution of conjoint and disjoint forms interacts with the IAV. In fact for Makhuwa, it has been argued that the conjoint form of the verb indicates that a structural position corresponding to the IAV linear position is filled (van der Wal 2006).

The analysis which has been proposed for Smbaa and Haya in the previous chapters, would not predict systematic differences for object marking patterns in *wh*-environments between the two languages. Similarly, the analysis proposed by Bresnan and Mchombo (1987) would not predict there to be any differences between Swahili and Smbaa and cannot easily account for the agreement patterns found in the two lan-

guages with different types of elements. However, there are clear differences between all three languages regarding object marking in *wh*-contexts. In Sambia, there are differences between *wh*-questions and cleft-questions on one hand and relative clauses on the other hand. In Haya, object marking is impossible in *wh*-environments.

In this chapter, I discuss object marking patterns for *wh*-elements in Swahili and Sambia. The discussion starts by looking at simple *wh*-questions. Section 6.1.3 discusses relative clauses. Section 6.1.4 discusses cleft questions. Having described the patterns found across a range of *wh*-environments in those two languages, I examine the syntax of those types of constructions in Sambia. I then compare Haya to Sambia and Swahili. In search for a unified analysis of the three languages, the final section examines the effects of specificity and the cross-linguistic correlations between specificity and object agreement.

## 6.1 Object marking in *wh*-environments

### 6.1.1 *Wh*-questions

In Swahili and Sambia, object marking is obligatory with certain kinds of *wh*-words. However, the semantic class of nouns this applies to is different from the class of nouns which trigger obligatory object marking in non-questions, as described in chapter 3. Moreover, in Sambia, there is a class of *wh*-elements which cannot be object-marked. In Swahili, there is a strong dispreference for object marking certain types of *wh*-objects as well.

**Human Objects** In Swahili, object marking *who* in object questions is obligatory. This is shown in (1). For Swahili this might be expected since all animates must be object-marked in non-questions as well.

- (1) U- li- \*(mw)- ona nani?  
 SM2S- PAST- OM1- see who  
 ‘Who did you see?’ [Swahili]

However, in Sambia object marking a *who*-object is also obligatory, as shown in (2).

- (2) U- \*(mw)- ene ndayi?  
 SM2S- OM1- see.PERF.CJ who  
 ‘Who did you see?’ [Sambia]

In Sambia, the obligatory object marking for *who*-objects is unexpected, since, as shown in chapter 3, in non-questions only a small subset of human objects requires object marking and the question word ‘who’ does not neatly fit into that category. However, the same object marking pattern is reported for other Bantu languages which also have obligatory object marking only for a subset of nouns referring to humans. Examples of this are Ruwund (Nash 1992) where only specific human objects require object marking, and Makhuwa, where all class 1/2 nouns require object marking regardless

of their animacy status (van der Wal, p.c.). In Makhuwa, class 1/2 includes animates and many inanimates, and therefore not as closely associated with humans as in other Bantu languages.

**Inanimate Objects** For inanimate objects, object marking is ungrammatical in Sambia in *wh*-questions. (3a) shows a grammatical *what*-question. Its object-marked counterpart is shown in (3b). With object marking the ‘what’ reading is unavailable, but because *mbwai* can also mean ‘why’ in Sambia, the sentence is grammatical with the interpretation of ‘Why did he see it?’.

- (3) a. A- ene mbwai?  
SM1- see.PERF.CJ what  
‘What did he see?’
- b. A- i- ene mbwai?  
SM1- OM9- see.PERF.CJ what  
\* ‘What did he see?’  
✓ ‘Why did he see it?’ [Sambia]

As discussed in the section on obligatory object marking in chapter 3, certain types of nouns trigger obligatory agreement in Sambia. To this group *ndayi* ‘who’ can be added. Unlike in non-questions, a new semantic class of object nouns becomes apparent: objects which cannot agree. These include *mbwai* ‘what’.

The fact that some types of objects can be object-marked while others cannot, shows that whether object marking is grammatical in *wh*-questions cannot be used as a test for the status of the object marker, as suggested in Bresnan and Mchombo (1987).

The sentence in (3b) has a class 9 object marker. The *what*-reading does not become available with any other object marker for a class used to refer to inanimate entities either. However, typically, in Bantu languages like Sambia, class 1/2 is for human objects. The question word ‘who’ questions only human objects, whereas non-human objects can belong to a number of different noun classes. One could think that this may be the reason for the difference between *what* and *who*-questions in Sambia. Namely, that a non-human *wh*-word cannot be assigned to a noun class because its gender is lexically unspecified. However, there are complex *wh*-elements referring to inanimate objects which overtly show noun class agreement or include a head noun, such as the d-linked *wh*-element *-hi* ‘which’. But, as shown in (4), these are equally ungrammatical with object marking in Sambia. In section 6.2.2, I show that d-linked *wh*-elements are different from non-d-linked *wh*-elements in terms of word order in Sambia, even though they show the same object marking patterns.

- (4) U- (\*chi)- ghul- iye kitabu chihi?  
SM2S- OM7- buy- PERF.CJ 7book 7which  
‘Which book did you buy?’ [Sambia]

In Swahili, unlike in Sambia, object marking a *wh*-word referring to a questioned inanimate entity is grammatical. Not all speakers judge (5a) as acceptable, but in clear

contrast to Sambia, there are speakers of Swahili who judge sentences like (5a) as completely acceptable. Moreover, in Swahili, there is a difference between *which*-questions and *what*-questions. In contrast to the Sambia sentence in (4), the Swahili sentence in (5b), with a *which*-phrases was judged as perfectly grammatical by all speakers consulted.

- (5) a. % U- li- (ki)- pata nini?  
           SM2S- PAST- OM7- get what  
           ‘What did you get?’  
       b. U- li- (ki)- pata kitabu kipi?  
           SM2S- PAST- OM7- get 7book 7which  
           ‘Which book did you get?’ [Swahili]

For two languages which are generally argued to have object agreement, we have so far seen four different gradients of grammaticality in *wh*-questions: obligatory, acceptable, dis-preferred and ungrammatical object marking. We have also seen that the Swahili data is more complex than implied in Bresnan and Mchombo (1987).

**Animacy hierarchy effects** In Sambia and Swahili, object marking for human objects in *wh*-questions is subject to animacy effects. In Swahili, there are apparently also some definiteness effects. These apply somewhat differently when compared to object marking in non-questions but show similar effects. But, surprisingly, for non-human objects, Sambia does not allow object marking at all. Animacy is more decisive in Sambia *wh*-questions than in other contexts. In *wh*-questions, the large group of objects which can optionally be object-marked in assertions loses this property. In chapter 3, animacy and definiteness hierarchies (Aissen 2003) and (Croft 2003) were introduced. These are repeated in (6).

- (6) a. Animacy: human > animate > inanimate  
       b. Definiteness: definite > indefinite specific > non-specific  
       c. Definiteness and Animacy (Croft 2003): first/second person pronouns >  
           third person pronoun > proper names >  
           human common noun > non-human animate common noun >  
           inanimate common noun

In Sambia, it appears that in *wh*-environments, the differential object marking hierarchy is bidirectional, determining both what must be and what cannot be object-marked. Whereas in non-*wh*-environments, it is unidirectional, determining only what must be object-marked. In questions, the relevant hierarchy is the animacy hierarchy. *Wh*-words are indefinite, and categories such as proper name, personal pronoun and common noun do not apply at all. If specificity is taken to be presupposition of existence (Bhatt and Anagnostopoulou 1996; Diesing 1992), d-linked *wh*-elements might be considered more specific than non-d-linked *wh*-elements, since they presuppose the existence of a known set of entities from which the answer will be taken. Other definitions of specificity require a unique reference as well as a presupposition of existence

(Sio 2006). Under such a definition, *which*-phrases would not be specific. However, É. Kiss (1993) treats *which*-phrases as specific, while for English, *which*-phrases have even been argued to be definite (Beck and Rullmann 1999; Rullmann and Beck 1998). Without discussing the semantics of *which*-phrases and other types of *wh*-elements, one can say that *which*-phrases are higher on the definiteness scale than other types of *wh*-phrases. The Swahili data can be analysed as showing sensitivity to the definiteness hierarchy in (6b), as well as the animacy hierarchy in (6a).

In the Sambia data discussed here, there are no differences between d-linked and non-d-linked *wh*-questions with respect to object marking. However, in section 6.1.2, I examine human objects more closely, and shown that there are some definiteness effects in Sambia *wh*-questions as well.

### 6.1.2 Sambia human objects

Having discussed the differences between human and non-human objects, let us look at some more fine-grained grammaticality judgements for Sambia human objects in *wh*-questions. The data presented here show that Sambia object marking in *wh*-questions is not only affected by animacy but also by definiteness, rather like the Swahili non-human objects. Sambia has an alternative form of the question word for ‘who’, *wandayi*, which is morphologically marked as plural. Unlike *ndayi*, this *wh*-word does not require object marking, as shown in (7).

- (7) U- (wa)- ene wandayi?  
 SM2S- OM2- see.PERF.CJ who.PL  
 ‘Who[pl] did you see?’ [Sambia]

*Ndayi* can be used with class 2 object marking, as shown in (8a). However, *wandayi* cannot be used with class 1 object marking, as shown in (8b). It appears that, while *wandayi* is marked as plural, *ndayi* is unmarked for number.

- (8) a. U- wa- ene ndayi?  
 SM2S- OM2- see.PERF.CJ who  
 ‘Who[pl] did you see?’  
 b. \* U- mw- ene wandayi?  
 SM2S- OM1- see.PERF.CJ who.PL  
 Int: ‘Who[pl] did you see?’ [Sambia]

For objects questioned with *which*-phrases, object marking is optional in Sambia. This is shown in (9).

- (9) U- (mw)- ene ng’wana yuhi?  
 SM2S- OM1- see.PERF.CJ 1child 1which  
 ‘Which child did you see?’ [Sambia]

The same effect is shown by other *wh*-phrases with an overt head noun, such as ‘how many’, as illustrated in (10). Although ‘how many’ is not a *which*-phrase in

English, it has some semantic and syntactic similarities, as it restricts the possible answers to a similar set as a *which*-phrase. Moreover, in Sambia the same morphological element, *hi*, is used in both. We can therefore treat this kind of construction together with *which*-phrases.

- (10) U- (wa)- alik- e wantu wangahi?  
 SM2S- OM2- invite- PERF.CJ 2people 2how.many  
 ‘How many people did you invite?’ [Sambia]

The data in this section seems to indicate that the definiteness hierarchy does play a role in Sambia *wh*-agreement. However, unlike in Swahili, in Sambia this makes object marking non-obligatory. This might be generalized for the two languages by saying that more definite *wh*-phrases in Sambia and Swahili behave more like non-questioned objects. In Sambia, this effect is restricted to human objects. We can also generalize that with all *wh*-words referring to human objects, object marking is grammatical in Sambia (with obligatory or optional presence).

### 6.1.3 Object marking in relative clauses

Relative clauses are generally argued to involve head raising in current syntactic theory, following Kayne (1994). Relative clauses are commonly argued to have a kind of operator feature, similar to *wh*-questions. *Wh*-clefts, which are discussed in section 6.1.4 also involve relative clause morphology. This is relevant for Sambia, where clefts and relative clauses differ in terms of object marking patterns. But more importantly, relative clauses involve movement of the relativized element to a position outside of the clause. This can be expected to affect object marking patterns in the cases where the moved element is an object. According to Henderson (2006b), object marking in relative clauses could be used to differentiate between pronominal and agreement type object marking. This makes it relevant to our discussion here to examine when object marking is possible, required or ungrammatical in object relatives.

In Swahili object relative clauses, object marking is required for animates and is optional for inanimates. This means that the object marking patterns are the same as in non-relative clauses.<sup>1</sup> An example of an animate object is shown in (11a)<sup>2</sup>. Without the object marker, native speakers of Swahili reject this sentence as ungrammatical. The fact that object marking is optional with an inanimate object is illustrated in (11b) and (11c). The verb and object and relativization strategy used are the same in both cases, the only difference is the presence or absence of the object marker. The sentences in (11b) and (11c) are taken from the same newspaper, where both variants come up multiple times in an archive search.

<sup>1</sup>As Thilo Schadeberg (p.c.) points out, there are some differences in frequency. For inanimates in Swahili, object marking is rare in non-relative clause contexts. In object relative clauses, it is much more frequent to the extent that it has been claimed to be obligatory (Ashton 1944).

<sup>2</sup>In Swahili, nouns like *askari*, which refer to humans but grammatically belong to classes other than 1/2, trigger class 1/2 agreement on the verb.

- (11) a. Wachezaji a- li- o- wa- ita kwa ajili ya  
 2player SM1- PAST- RM2- OM2- call 17ASSOC 9purpose 9ASSOC  
 mechi hiyo ni ...  
 9DEM COP  
 ‘the players that he called for the match are...’  
 [Swahili, source: Nipashe, 10 March 2009]
- b. ... ku- omba msamaha kwa makosa wa- li- yo- ya-  
 INF- beg 3forgiveness 17ASSOC 6mistake SM2- PAST- RM6- OM6-  
 tenda ...  
 do  
 ‘to ask forgiveness for the mistakes that they made...’  
 [Swahili, source: Tanzania Daima, 3 February 2008]
- c. ... wa- ta kiri makosa wa- li- yo- tenda ...  
 SM2- FUT- admit 6mistake SM2- PAST- RM6- OM6- do  
 ‘they will admit the mistakes that they made...’  
 [Swahili, source: Tanzania Daima, 13 July 2008]

In Smbaa object relative clauses, object marking is optional. This is shown in (12a) for the inanimate object *matonte*. Object marking is also optional for the human direct object in (12b).

- (12) a. Matonte n- (ya)- m- nk- iye- yo ya- aa- izw-  
 6banana SM1S- OM6- OM1- give- PERF -RM6 SM6- REM.DJ- ripen.PASS-  
 iye.  
 PERF.CJ  
 ‘The bananas which I gave him are ripe.’ (*yaaizwiye* is disjoint)
- b. Mvyee a- ye- (m)- nka lifti a- a- tamiwa.  
 1woman SM1- RM1- OM1- give.PRES 9lift SM1- CONT.DJ- please.PASS  
 ‘The woman who she gives a ride is happy.’ [Smbaa]

The class of objects which trigger obligatory object marking in non-relative clauses (proper names of humans, first and second person pronouns, and unique titles or kinship terms) do not appear in restrictive relative clauses. In an appositive construction with a head noun from this class, object marking is obligatory, as shown in (13).

- (13) Juma ti- ye- \*(mu-) ondeza a- za- ki- fisha. ‘Juma,  
 1Juma SM2P- RM1- OM1- search.PRES SM1- PERF.DJ- REFL- hide  
 the one we are looking for, is hiding (himself).’ [Smbaa]

For Swahili and Smbaa, Henderson’s test appears to work. Both are agreement languages, according to the criteria used by Henderson (2006b) and those used by Bresnan and Mchombo (1987), and both freely allow object marking in relative clauses. However, when the results are compared to the pattern with *wh*-questions, the results of the two tests do not match.

### 6.1.4 Object marking in *wh*-clefts

Agreement patterns with clefts have not been discussed with regard to the agreement/pronoun distinction. Cleft questions in both languages require verbs marked with relative clause morphology. We might therefore expect cleft questions to behave like relative clauses. However, this is not what we find in Smbaa.

In Swahili, cleft questions pattern with relative clauses: as expected, object marking is required for human objects, as shown in (14a) and optional for inanimate objects, as shown in (14b). The object marking judgement in (14b) is like that found in relative clauses insofar as the object marker is robustly grammatical for all speakers. For relative clauses there is no grammaticality difference between object marking for non-d-linked *wh*-elements, as the sentence in (14b), and object marking for d-linked ones, as in (14c).

- (14) a. Ni nani u- li- ye- \*(m)- pa kitabu?  
 COP who SM2S- PAST- RM1- OM1- give 7book  
 ‘Who was it that you gave a book?’
- b. Ni nini u- li- cho- (ki)- nunua?  
 COP what SM2S- PAST- RM7- OM7- buy  
 ‘What was it that you bought?’
- c. Ni kitu gani u- li- cho- (ki)- nunua?  
 COP 7thing which SM2S- PAST- RM7- OM7- buy  
 ‘What (lit. which thing) was it that you bought?’ [Swahili]

In Smbaa cleft questions, object marking is required for human objects, as shown in (15a), but ungrammatical for non-humans, as shown in (15b). This is the same pattern as in non-cleft *wh*-questions.

- (15) a. N’ ndayi u- \*(mw)- ene- ye ghulo?  
 cop who SM2S- OM1- see.PERF- RM1 yesterday  
 ‘Who was it that you saw yesterday?’
- b. M’ mbwai a- (\*ya)- ghul- iye- yo?  
 COP what SM1- OM6- buy- PERF.CJ- RM6  
 ‘What thing was it that he bought?’ [Smbaa]

In Swahili, then, cleft questions pattern like relative clauses and non-cleft questions; whereas in Smbaa cleft-questions pattern like non-cleft questions, rather than like relative clauses, in spite of their shared morphological properties. The fact that, in Smbaa, cleft-questions pattern unlike relative clauses might be evidence that object marking is sensitive to a [+/-*wh*]-feature. But even with such an analysis, the fact that in Smbaa some *wh*-objects must be object-marked remains problematic, since this pattern cannot be explained by adding the relevant features together.

## 6.2 Structural implications

In the first section of this chapter, we discussed object marking patterns across a range of *wh*-environments. They were found to differ with respect to object marking. In Sambiaa, cleft questions patterned with non-cleft *wh*-questions, and relative clauses patterned with non-questions. In chapters 2, 3 and 4, it was shown that object agreement is between the Probe and its closest c-commanded object. This syntactic configuration is different in cleft-questions and relative clauses which have a gap where an object would be. The element which is interpreted as the object is not c-commanded by AgrOP in either type of construction. Most *wh*-elements do not at first sight seem to move in Sambiaa. However, I will show here that non-d-linked elements appear to have moved even when they appear in postverbal position. While this cannot explain the differences between human and non-human objects, based on those facts it is at least to be expected that Agree might function differently with *wh*-questions.

### 6.2.1 Conjoint/disjoint forms in *wh*-questions

In chapter 2 and section 3.3.2, the conjoint/disjoint alternation was introduced. It was shown that a conjoint form in Sambiaa cannot appear in phrase-final position. However, unlike in Zulu, there was no interaction between the conjoint/disjoint distinction and object marking. In a number of Bantu languages, the conjoint/disjoint alternation interacts with focus. A focal element must be preceded by a conjoint form (Buell 2005, 2006; Ndayiragije 1999).

In Sambiaa a *wh*-element which appears postverbally must be preceded by a conjoint verb form, as shown in (16a). With a disjoint form of the verb, the sentence becomes ungrammatical, as in (16b). Since Sambiaa has many more disjoint forms than conjoint forms, only a very small number of its tense-aspect distinctions can be expressed in *wh*-questions.

- (16) a. U- mw- ene ini Juma?  
SM2S- OM1- see.PERF.CJ when 1Juma  
'When did you see Juma?'
- b. \* U- za- mw- ona ini Juma?  
SM2S- PERF.DJ- OM1- see when 1Juma  
Int: 'When did you see Juma?' [Sambiaa]

If the *wh*-element is not postverbal, the disjoint form will be used if nothing follows the verb, as shown in (17).

- (17) a. Kwai fua i- za- gwa?  
why 9rain SM9- PERF.DJ- fall  
'Why is it raining?'
- b. \* Kwai fua i- gweye?  
why 9rain SM9- fall.PERF.CJ  
'Why is it raining?' [Sambiaa]

In languages like Zulu or Rundi, the conjoint form must also be used with other types of focus (Buell 2006; Buell and Riedel 2008; Ndayiragije 1999). This is not the case in Smbaa. For example, in a question-answer pair, the element which fills in for the *wh*-element is the focus of the sentence. As the sentence in (18b) shows, in Smbaa the disjoint form can be used here.

- (18) a. Q: Mw- inuke zeze?  
           SM2P- arise.PERF.CJ how  
           ‘How did you wake up?’  
       b. A: Ti- za- inuka wedi.  
           SM1P- PERF.DJ- arise 2well  
           ‘We woke up well.’ [Smbaa]

The disjoint form is not only used with adverbials like ‘well’ but also with objects, as shown in (19).

- (19) a. Q: W- ita hii?  
           SM2S- go.PRES.CJ where  
           ‘Where are you going?’  
       b. A: N- a- ita kaya.  
           SM1S- PRES.DJ- go 9home  
           ‘I’m going home.’ [Smbaa]

These kinds of effects show that *wh*-objects are different from other types of objects in Smbaa. In the next section we look at the position they appear in.

### 6.2.2 The Immediate After the Verb (IAV) Position

In many Bantu languages, focal elements must appear in the position immediately following the verb. IAV effects are not systematic across Bantu, but the languages that show them seem to share some core properties. In Smbaa, IAV effects are very clear with *wh*-words but very weak with other types of focal elements. IAV effects in Bantu have been discussed in the Bantu literature since Watters’ (1979) paper on focus in Aghem. They are frequently linked to a particular structural position. The linear IAV position has been argued to correspond to a structural focus position below TP for a number of Bantu languages (Ndayiragije 1999; van der Wal 2006). There are also arguments against such an analysis (Buell 2009b; Hyman and Polinsky 2006). An alternative analysis to the structural IAV position can achieve the focus-effect by right-dislocating or extraposing all non-focal elements. This is argued for Zulu in Buell (2009b) and in Cheng and Downing (2009). In Zulu, all the other elements have to move out of the vP in *wh*-questions, and must be object-marked. I will show that Smbaa is different from Zulu and argue for a structural IAV position for Smbaa. Across Bantu, focal elements in IAV position must follow a conjoint verb in most Bantu languages (Buell 2009b; Ndayiragije 1999; van der Wal 2006).

In Ndayiragije’s (1999) analysis, the IAV is a syntactic position between TP and VP, as shown in (20). In his account, the verb raises to T (in order for the focal element

to be postverbal) and the focal element moves to the specifier of the FocP. Note that, unlike all other phrases, the FocP has its specifier on the right.

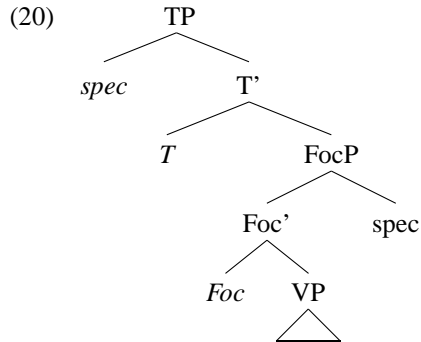

A very similar structure, but with the specifier of FocP on the left, has also been argued for questions in Malayalam by Jayaseelan (2002, 2003).

In van der Wal (2006), the FocP (FocP, which she calls FP) is merged below vP, following Baker and Collins (2006). She argues that the verb does not raise to T but remains in vP. Her structure is shown in (21).

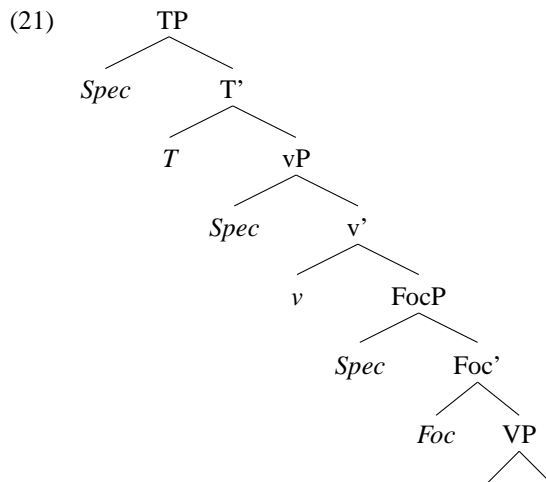

I will suggest a slight variation on the structures suggested in van der Wal (2006) and Jayaseelan (2003) below.

### 6.2.3 Word order effects

In Sambaa, there are different word-order requirements for *wh*-questions and non-questions. This is particularly noticeable in double object constructions or other constructions with more than one postverbal constituent such as transitive verbs followed by an adjunct. As argued in chapters 2 and 3, the word order of the complements in a

DOC and the order of the objects with respect to any adjuncts is fixed, with the order shown in (22).

(22) **Non-question:** V IO DO XP

However, in Smbaa a *wh*-element typically has to appear in the IAV position. This is irrespective of its syntactic status, as indirect object, direct object or adjunct. The basic word order in *wh*-object-questions is shown in (23).

(23) **Question:** V *wh* XP

The differences in word order are evidence for a structural IAV position. There is some variation between speakers for the grammaticality judgements for these constructions. Not all speakers judge sentences where the *wh*-element does not appear in the IAV position as ungrammatical, but there is always a clear preference for *wh*-element in the IAV position, and the contrast between questions and non-questions is clear. This is illustrated in (24) with a double object construction.

- (24) a. U- m- nk- iye mbwai Stella?  
SM2S- OM1- give- PERF.CJ what Stella  
'What did you give Stella?'  
b. \* U- m- nk- iye Stella mbwai?  
SM2S- OM1- give- PERF.CJ Stella what  
Int: 'What did you give Stella?' [Smbaa]

Non-argument *wh*-items also appear in the IAV position in Smbaa, as shown in (25a) and (25b). These kinds of *wh*-phrases are somewhat more free to appear in a position other than the IAV position than object *wh*-elements. This has also been reported for Zulu locatives (Buell 2009b).

- (25) a. U- mw- ene ini Juma?  
SM2S- OM1- see.PERF.CJ when 1Juma  
'When did you see Juma?'  
b. U- dik- iye zeze zia nkande?  
SM2S- cook- PERF.CJ how 10DEM 10food  
'How did you cook this food?' [Smbaa]

When the question word *zeze* appears in sentence-final position, it has a different reading. In (25b), where it appears in IAV position, the interpretation is of manner, while in (26), where it appears in sentence-final position, it has a 'how come' reading. Apart from *zeze* with the 'how come'-reading, there are two other *wh*-elements which do not tend to appear in IAV position: subjects and the question word 'why'.

- (26) U- dik- iye zia nkande zeze?  
SM2S- cook- PERF.CJ 10DEM 10food how  
'How come you cooked this food?' [Smbaa]

**D-linked *wh*-elements** The word order is different with d-linked *wh*-elements. If a d-linked *wh*-phrase is the direct object of a double object construction, it cannot appear in the IAV position, preceding the indirect object, as (27a) shows. Instead, the d-linked direct object appears after the indirect object, as in (27b). This is the same word order as in non-questions.

- (27) a. \* U- m- nk- iye kitabu chihi Stella?  
 SM2S- OM1- give- PERF.CJ 7book 7which 1Stella  
 Int: ‘Which book did you give Stella?’
- b. U- m- nk- iye Stella kitabu chihi?  
 SM2S- OM1- give- PERF.CJ 1Stella 7book 7which  
 ‘Which book did you give Stella?’ [Sambaa]

**Subject questions** In Sambaa, as in many, but not all, Bantu languages (Sabel and Zeller 2006), a subject may not be questioned in spec,TP, or more generally preverbally. Instead, clefts are used to question a subject. Ungrammatical subject-questions with preverbal *who* are shown in (28). These are not affected by the conjoint/disjoint alternation, since both the conjoint and the disjoint form of the verb are ungrammatical here.

- (28) a. \* Ndayi a- kund- iye?  
 1who SM1- want- PERF.CJ  
 Int: ‘Who wanted (it)?’ (conjoint)
- b. \* Ndayi a- za- kunda?  
 1who SM1- PERF.DJ- want  
 Int: ‘Who wanted (it)?’ (disjoint) [Sambaa]

Subject questions must be clefted, as shown in (29a). For intransitives, the question word in a subject-question can also appear postverbally, as shown in (29b). With the postverbal subject-question strategy there is no agreement between the *wh*-word and the verb, instead the verb is marked with a class 17 subject marker, which might be analysed as a kind of expletive.

- (29) a. N’ ndayi a- iz- iye- ye?  
 cop 1who SM1- come- PERF.CJ- RM1  
 ‘Who is it that came?’
- b. Ku- iz- iye ndayi?  
 SM17- come- PERF.CJ who  
 ‘There came who?’ [Sambaa]

**Why-questions** In Sambaa, the question word *kwai* ‘why’ also cannot appear in the IAV position. Instead it appears to be fronted to the sentence-initial position or merged

there, as shown in (30a). Other question phrases<sup>3</sup> which are used to ask *why*-questions also appear in this position, as shown in (30b).

- (30) a. Kwai u-      za-      uka?  
           why SM2S- PERF.DJ- leave  
           ‘Why did you leave?’
- b. Kwa      mbwai a-      ku-      etea      matagi?  
           17ASSOC what SM1- OM2S- bring.APPL.CJ 6egg  
           ‘Why did s/he bring you eggs? (lit. of/for what)’
- c. A-      ku-      etea-      i      matagi?  
           SM1- OM2S- bring.APPL.CJ- WHAT 6egg  
           ‘Why did s/he bring you eggs?’ [Sambaa]

We can conclude that *kwai*, either undergoes *wh*-movement, is merged in clause-initial position. Marginally, for some speakers *kwai* can also appear after the verb. If this is the case, the verb must be in the conjoint form, as shown in (31).

- (31) a. % A-      iz      -iye      kwai?  
           SM1- come- PERF.CJ- why  
           ‘Why did he come?’
- b. \* A-      za-      iza      kwai?  
           SM1- PERF.DJ- come why  
           ‘Why did he come?’ [Sambaa]

**Conclusions** The data presented in this section show that certain non-d-linked *wh*-elements have to appear in a position immediately after the verb. These include objects and most adjuncts. Subjects have to be clefted, while high adjuncts appear in sentence-initial or sentence-final position. A structural IAV is the simplest solution to account for these effects. In the next section, the structural implications of this analysis are discussed.

#### 6.2.4 Evidence for a structural IAV

The IAV has been argued not to be a structural position in Zulu. The strongest evidence for this view of Zulu morphosyntax are what Buell (2009b) calls the “no-crossing effects” and the “no postfocal material effects”. The no-crossing effect appears when an object moves across an element which would follow it in non-*wh*-question word order, in order to appear in the IAV position, whereas the no postfocal material effect appears when other material follows an element in IAV position. Both configurations are ungrammatical in Zulu within the verb phrase. These kinds of effects are consistent with an analysis where an element appears in IAV position because the other elements have moved outside of the VP (the view taken in Buell (2009b)), rather than one

<sup>3</sup>Note that *kwai* consists of *kwa*, the associative form of class 17, which is used as a preposition meaning *for* or *of*, and the *wh*-clitic *-i* which means ‘what’. This means the two forms consist of the same two elements ‘for’ and ‘what’.

where an element moves to the IAV position. In Buell's analysis, in Zulu, verb-phrase-external objects are those which are not object-marked, while object-marked objects are not inside the verb phrase. Object marking interacts with these effects in Zulu. Constructions which are ungrammatical without object marking are often grammatical with object marking. The no-crossing effect is illustrated in (32). In Zulu, 'how' in IAV position cannot be followed by a direct object.

- (32) \* Ba- bhak- a kanjani isinkwa?  
 SM2- bake- FV how 7bread  
 'How do they bake bread?' [Zulu, Buell 2009b:168]

In (32), an example of the ungrammaticality of postfocal elements in Zulu is shown. Here the indirect object is questioned and is followed by the direct object, which is not object-marked. Since in Zulu, as in Swahili and Smbaa the basic word order is SV IO DO, no crossing-over would be necessary here for the focal element to appear in the IAV position, yet the sentence is ungrammatical.

- (33) \* U- zo- thwal- is- a bani leli tafula?  
 2S- FUT- carry- CAUS- FV who 5that 5table  
 'Who will you help carry that table?' [Zulu, Buell 2009b:169]

Unlike in Zulu, in Smbaa there are no crossing-over or postfocal effects. In Smbaa, the object, which is not object-marked, can follow the *wh*-adjunct, as shown in (34). To get to this position it would be crossing over the direct object. There are clear differences between inanimate (direct) objects in Zulu and in Smbaa.

- (34) U- dik- iye zeze zia nkande?  
 SM2S- cook- PERF.CJ how 10DEM 10food  
 'How did you cook this food?' [Smbaa]

For human indirect objects, Smbaa also requires object marking. The pattern here is affected by the order of the complements. As was shown in chapter 3, it is generally not obligatory to object-mark a noun referring to a human, such as *ng'wana* 'child'. For the speakers who allow variation in the word order in *wh*-questions,<sup>4</sup> this is maintained when it appears as an indirect object in its base position, as shown in (35a). However, when the *wh*-word appears in the IAV position, it is ungrammatical to drop the object marker as shown in (35b).

- (35) a. Hu- (m)- ghul- iye ng'wana mbwai?  
 SM2S.NEG- OM1- buy- PERF.CJ 1child what  
 'What didn't you buy for the child?'  
 b. Hu- \*(m)- ghul- iye mbwai ng'wana?  
 SM2S.NEG- OM1- buy- PERF.CJ what 1child  
 'What didn't you buy for the child?' [Smbaa]

<sup>4</sup>Note that the relevant reading here is a d-linked reading. The context for this sentence is that a set of things needed to be bought for the child and the speaker is asking the hearer which of the things in that set were not bought. This might make this word order more acceptable.

In Zulu, this sentence would also be grammatical with object marking. The difference between the two languages becomes clear with inanimate objects.

In Sambia, the word order effect on object marking, for a non-questioned object which follows a *wh*-element, does not appear with non-human objects. There is a strong preference for the *wh*-word to appear in the IAV position, as in (36a), over (36b), where it appears after the object, but both sentences are grammatical without object marking.

- (36) a. U- ghul- iye hii matonhte?  
SM2S- buy- PERF where 6banana  
'Where did you buy bananas?'  
b. U- ghul- iye matonhte hii?  
SM2S- buy- PERF 6banana where  
'Where did you buy bananas?' [Sambia]

With animate non-human objects, object marking is also not obligatory, as shown in (37a).

- (37) a. U- ink- a mbwai ng'ombe yako?  
SM2S- give- PRES.CJ what 9cow 9your  
'What did you give your cow?'  
b. U- ink- a ng'ombe yako mbwai?  
SM2S- give- PRES.CJ 9cow 9your what  
'What did you give your cow?' [Sambia]

The data in examples (36) and (37) indicate that the non-questioned object is not right-dislocated. With right-dislocation, object marking is required for all kinds of nouns in Sambia, irrespective of their animacy status. There is no ungrammaticality in Sambia either with postfocal elements or with crossing-over. Therefore, in contrast to Zulu, there is no evidence that any other elements move in order for the *wh*-element to appear in the IAV position in Sambia.

**Multiple *wh*-questions** If there is one structural position where a *wh*-item can appear, we would expect multiple *wh*-questions to be ungrammatical, since no position might be available for the second element to move to, unless multiple structural focus positions are assumed. Moreover, there should be a grammaticality difference between sentences with two *wh*-elements that target the IAV position and sentences where only one of the *wh*-elements does. Both predictions turn out to be true for Sambia.

In Sambia, multiple *wh*-questions are generally judged as degraded. Two full *wh*-words following the verb are judged as severely degraded, as shown in (38). This is the case, irrespective of the order of the *wh*-elements.

- (38) a. \* U- ghul- iye hii mbwai?  
SM2S- buy- PERF.CJ where what  
Int: 'What did you buy where?'

- b. \* U- ghul- iye mbwai hii?  
 SM2S- buy- PERF.CJ what where  
 Int: ‘What did you buy where?’ [Sambaa]

Where multiple *wh*-questions are judged acceptable, constructions where the two *wh*-words do not both appear postverbally are used. If one *wh*-word follows the verb and one appears preverbally the equivalent of the sentence in (38) becomes acceptable, as shown in (39).

- (39) Hii u- ghul- iye- i?  
 where SM1- buy- PERF.CJ- WHAT  
 ‘Where did he buy what?’ [Sambaa]

However, cases where a *wh*-clitic appears in combination with a full *wh*-word are also preferred to those with two full *wh*-words, as in (40).

- (40) U- ghul- iye- i hii?  
 SM2S- buy- PERF.CJ- WHAT where  
 ‘What did you buy where?’ [Sambaa]

These facts are expected if there is a single syntactic position where the *wh*-word must appear. It is less clear why the questions with the *wh*-clitic are judged more acceptable. The syntax of *wh*-clitic in Sambaa, is unfortunately beyond the scope of this thesis.

**Conclusions** The data presented in this section support a view of the IAV position as a structural position in Sambaa. The lack of crossing-over or postfocal effects indicate that any other elements do not need to move in Sambaa, while the judgements for multiple *wh*-questions indicate that there is only one position available for an element which needs to be in IAV.

### 6.2.5 Representing the IAV position in syntax

For Rundi, Ndayiragije (1999) argues for a structure where there is a low focus projection, which he labels FocP, immediately below TP. The specifier of FocP is on the right. In Ndayiragije’s account, as shown in (41), the verb moves to T and the focal element, in (41) this is the subject, moves to spec,FocP. His analysis is for OVS structures, where the focal element is the final element in the clause. However, the FocP on the right cannot account for any IAV effects where the element in IAV is not clause final, unless all other elements were argued to be right-dislocated to a higher position.<sup>5</sup>

<sup>5</sup>This may in fact be a possible analysis for languages like Zulu because of the no cross-over effects described in Buell (2009b).

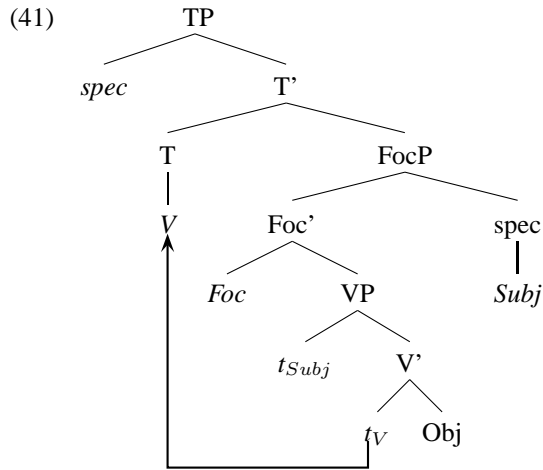

A specifier on the left for FocP would not cause this problem. An element could raise to the IAV position while the other elements stay in situ. With the additional structure assumed in this thesis to account for the agreement and aspectual heads, there are multiple projections that could be merging with Foc. However, for the IAV to be immediately postverbal while preceding any objects, it needs to be located below AspP and above VP. An appropriate structure is shown in (42). The IAV position here is the specifier of FocP. This account is very similar to the structure proposed in van der Wal (2006). However, for Sambiaa, the verb appears to raise higher than *v* because there are aspectual markers which are suffixed such as *-iye*.

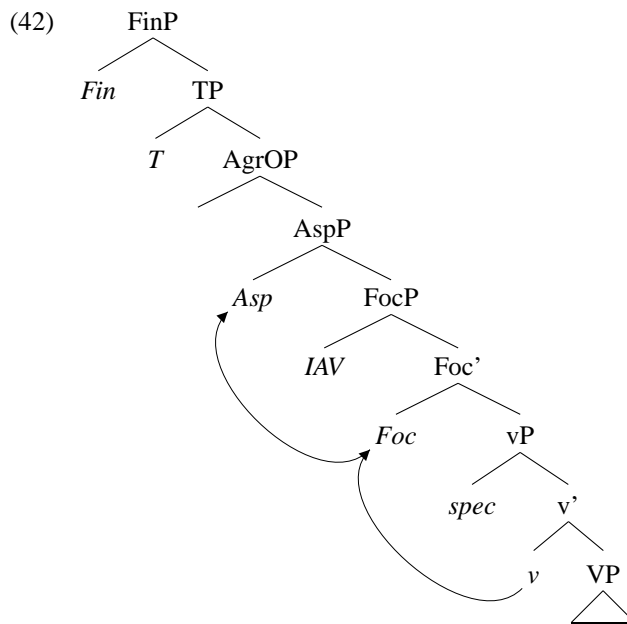

### Conclusions

The data and structures discussed in this section imply that Smbaa is not a true *wh*-in situ language. *Wh*-objects and the lower adjuncts move to the IAV position, while subjects need to be clefted. The only elements which really appear to be in situ are subject-questions with expletive agreement. For *why*-questions either movement to spec,CP or merging at sentence-initial position are possible analyses. In the next section we will look at the structure of relative clauses. This will support the structure in (42) by providing evidence for lexical material merged at FocP.

#### 6.2.6 Smbaa relative clause structure

As illustrated in section 2.3.6, Smbaa has a number of different strategies for relative clause formation. The relative markers, which exist in two morphological types, can be prefixed or suffixed to a verb or be attached to a preverbal copula or complementizer. One of these strategies has no subject marking morphology. However, where that is the case, the relative marker still shows full agreement with the subject. The word order with a relativized object is either SV or VS with a preference for SV. The distribution of the relative morphology in Smbaa is similar to that found in Swahili. However, the analyses for Swahili relative clauses do not fit our analysis of Smbaa clause structure. There are also word order differences between Swahili and Smbaa.

For Swahili, several people have argued that the relative marker attaches to the highest verbal element (Barrett-Keach 1986; Ngonyani 2001; Zwart 1997), which following Barrett-Keach (1985, 1986) is argued to include tense prefixes. For synthetic relative clauses in Swahili, it is argued that the verb raises to C, resulting in VS(O) word order (Ngonyani 2001; Zwart 1997). This would result in a VS word order. Indeed this is the word order for Swahili prefixed relative clauses, although Krifka (1995) has examples of SV order as well.

Examples of the relativization strategies available in Swahili are shown in (43). The *amba*- strategy, which is marginal in Smbaa, appears to work in the same way in both languages. The Swahili example is shown in (43a). In Swahili, SV order is judged as severely degraded or ungrammatical, this is shown in (43b). The grammatical sentence, with VS word order, is shown in (43c).

- (43) a. kitabu amba- cho Ali a- li- ki- soma (SV)  
       7book *amba*- RM7 1Ali SM1- PAST- OM7- read  
       Int: 'the book which Ali read'
- b. ?? kitabu Ali a- li- cho- ki- soma (SV)  
       7book 1Ali SM1- PAST- RM7- OM7- read  
       Int: 'the book which Ali read'
- c. kitabu a- li- cho- ki- soma Ali (VS)  
       7book SM1- PAST- RM7- OM7- read 1Ali  
       'the book which Ali read'

- d. kitabu a- soma- cho Ali (VS)  
 7book SM1- read- RM7 1Ali  
 ‘the book which Ali reads’ [Swahili]

In Sambia, both VS and SV word orders are grammatical in tensed relative clauses, while SV is generally preferred. The two orders are illustrated in (44). For VS, there is no reason to assume that the verb raises to *C*. Using the structure for the verbal morphemes we have been using here, it would also be a non-trivial matter to raise the verb. Remnant movement, where all other elements move out of the TP before the TP raises to *C* would be required. However, the verb will be argued to raise higher than Asp for some of the relativization strategies discussed here. Still, these can be derived without using remnant movement, or an analysis like the one proposed for Swahili by Ngonyani (2001) and Zwart (1997). Since, the VS order is the marked order, I will not discuss it further here.

- (44) a. kitabu Steve a- ghul- iye- cho (SV)  
 7book 1Steve SM1- buy- PERF- RM7  
 ‘the book which Steve bought’  
 b. kitabu a- ghul- iye- cho Steve (VS)  
 7book SM1- buy- PERF- RM7 1Steve  
 ‘the book which Steve bought’ [Sambia]

Let us now consider each relativization strategy in Sambia in turn. In Bantu, relative clauses are head external. The current theoretical analysis, following Kayne (1994), can be used to derive the basic structure of the relative clause. To derive the analytic type of relative clause is unproblematic. In (45), an example of the copular strategy is shown. The appropriate tree diagram for this sentence is shown in (46).

- (45) Kiti ndi- cho ng’wana ne- a- ghul- e m’ bei jedi.  
 7chair COP- RM7 1child FUT- SM1- buy- SUBJ COP 5price 5good  
 ‘The chair which the child will buy is cheap.’ [Sambia]

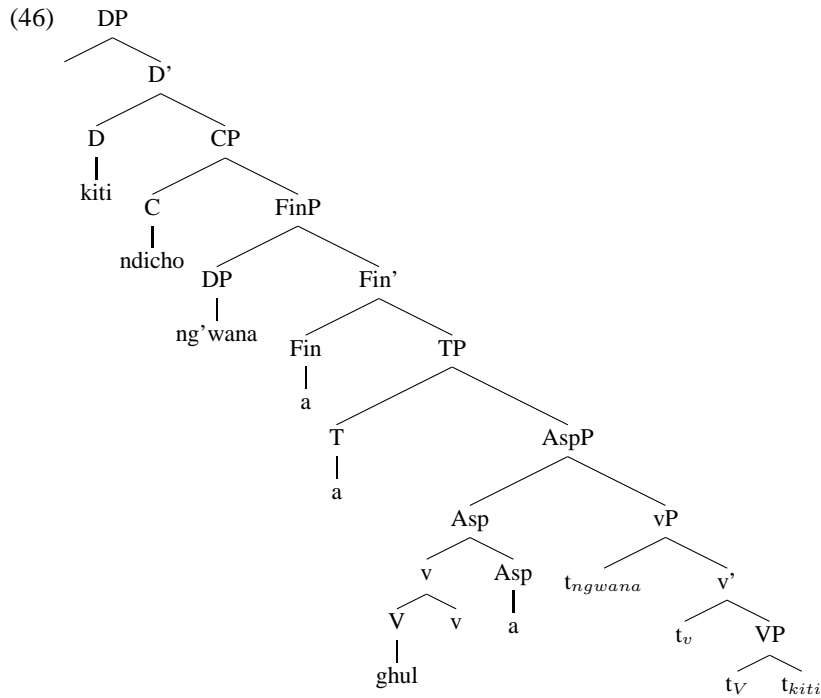

The synthetic type is harder to derive in a system where each morpheme is generated in a particular syntactic head. It appears that we need three different structures. Consider a prefixed relative clause with a subject marker, as in (47).

- (47) kiti ng'wana a- cho- ghula  
 7chair 1child SM1- RM7- buy.PRES  
 'the chair that the child buys' [Sambaa]

In the corresponding structure, in (48), the relative marker is the head of an XP which is attached just below TP and the verb raises to Asp, as we have argued for all Sambaa sentences.

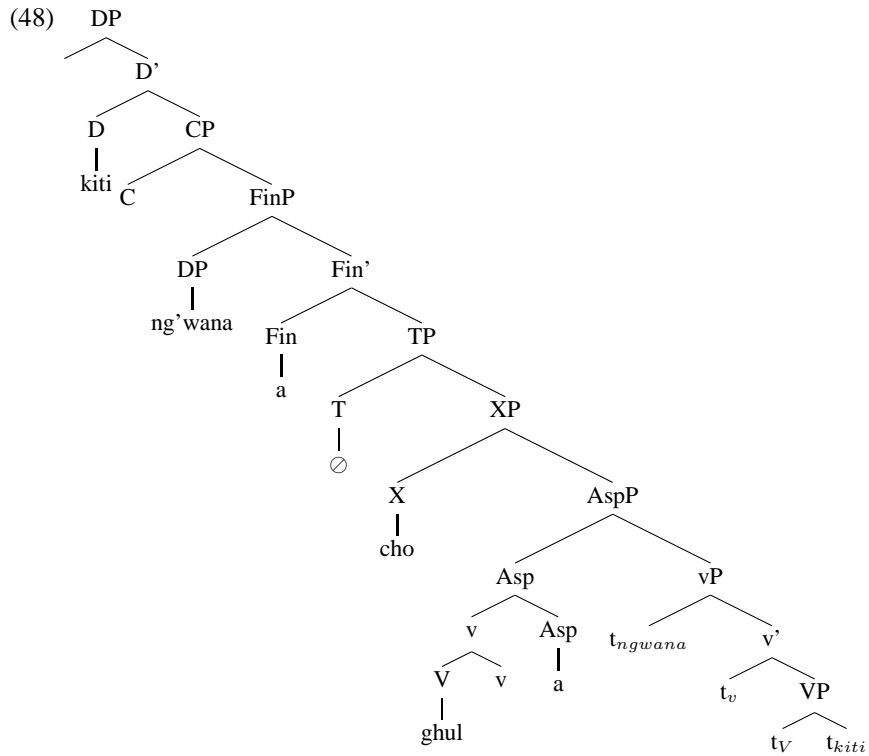

For the suffixed relative clause type, as in (49), a different structure is necessary. In the appropriate structure, shown in (50), the verb would have to raise all the way to X and left-adjoin to it, in order to get the right order of morphemes.

- (49) kiti ng'wana a- ghul- iye- cho  
 7chair 1child SM1- buy- PRES- RM7  
 'the chair that the child buys'

[Sambaa]

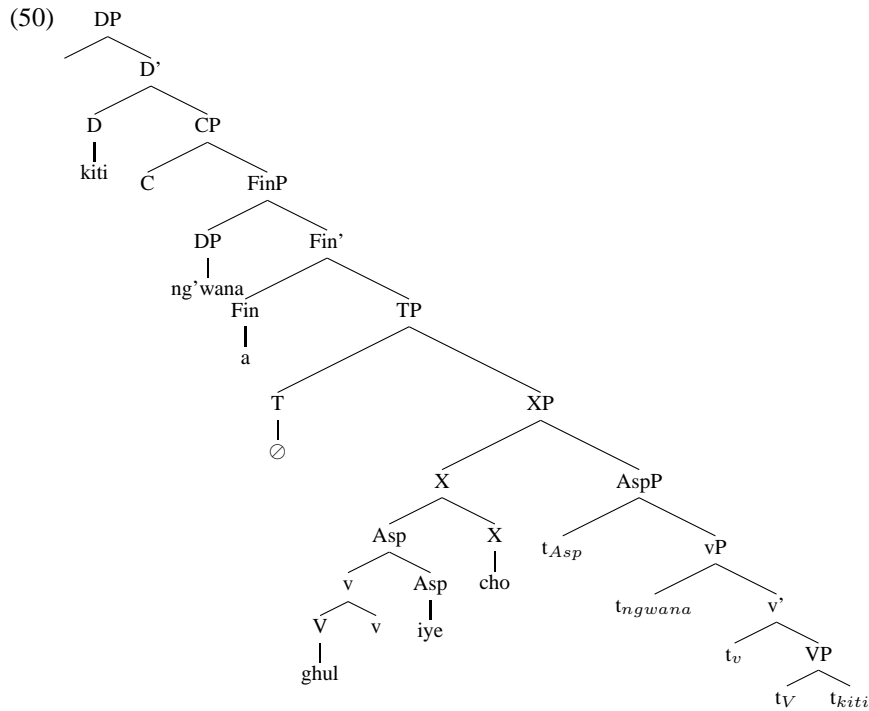

It is undesirable in theoretical terms to use two derivations for such similar structures. However, similar patterns are cross-linguistically widespread.

A third structure is necessary for the initial relative marker that appears without the subject marker, as in (51).

- (51) ng'wana mwe- ghula kiti  
 1child RM1- buy.PRES 7chair  
 'the child that buys the chair' [Sambaa]

In the corresponding structure, shown in (52), the relative marking morpheme is inserted in Fin to avoid projecting unnecessary structure. This kind of structure, with the relative marker inserted in Fin, following Rizzi (1997), is also proposed for Zulu in Henderson (2006b). However, the Zulu data would have a preverbal subject in these cases. Whereas, in Sambaa, because this structure is only found with subject relatives, the subject has always been extracted to a position outside of the CP.

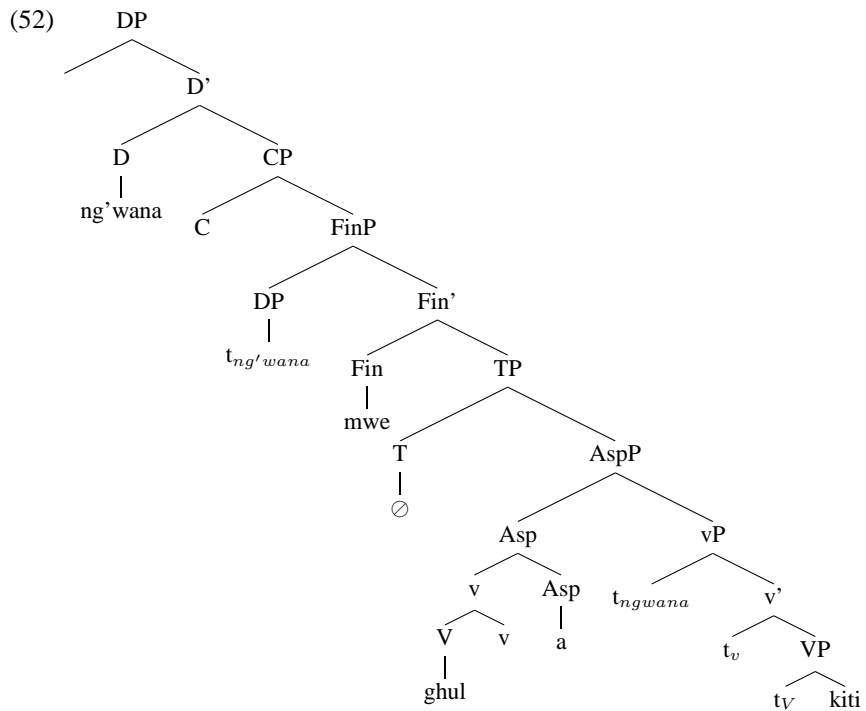

The number of structures necessary to account for the relativization patterns in Sambia, can be reduced somewhat by comparing relative clauses to the IAV position. In section 6.2.2, I argued that there is a FocP just above vP, as shown in (53).

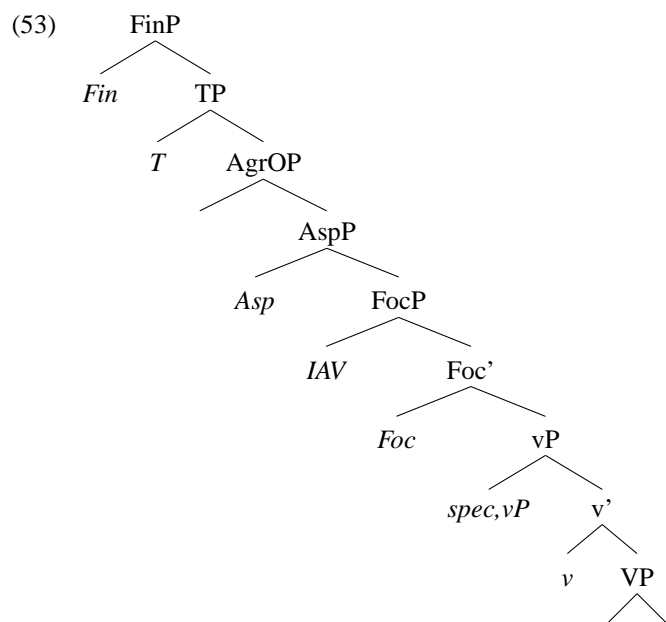

This structure can easily also account for the prefixed relative marker, if the relative marker is inserted at *Foc*. This is shown in (54).

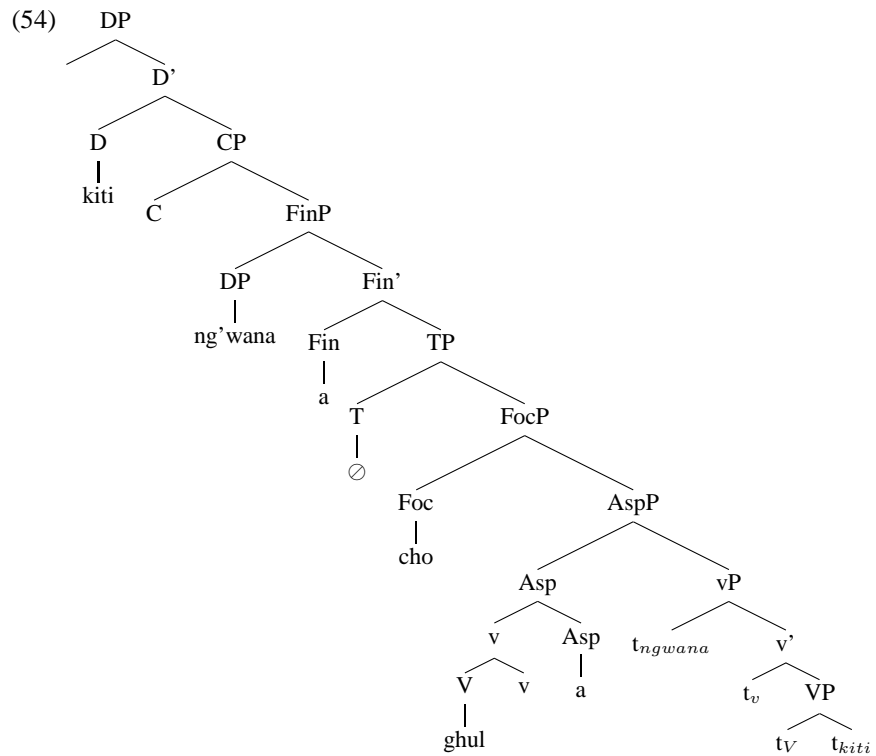

The suffixed relative marker does not follow immediately from this structure. However, the suffixed relative marker does not have a morpheme in the morphological slot associated with T. This means that nothing prevents the verb raising to T, after moving through Foc where the relative marker is attached, while maintaining the approach to morphology we have used throughout. The relevant structure is shown in (55).

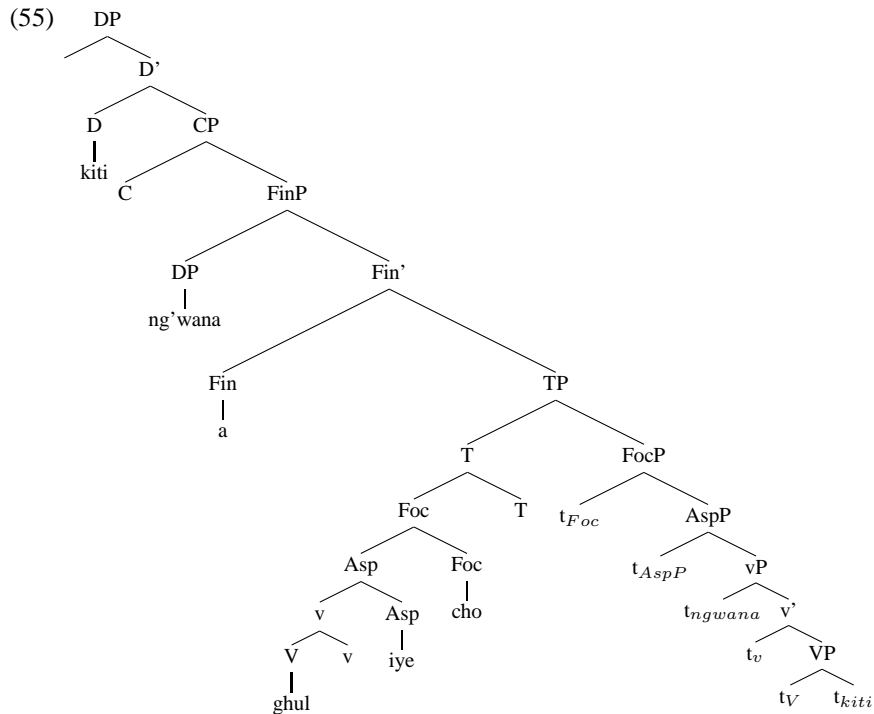

Relative markers that appear in low positions in Bantu do not only exist in Sambia and Swahili but have also been described for Zulu, where an apparently cognate invariable suffix *-yo* sometimes appears on relative verbs.

In this section, I have argued that relative clauses and *wh*-questions in Sambia share many of their syntactic properties. This does derive the differences in object marking patterns discussed at the beginning of this chapter. There is movement in relative clauses, as well as in *what*-questions, yet in the former object marking is possible while in the latter it is not. The best way to explain the Sambia data in *wh*-contexts is the animacy hierarchy. Having discussed the data and structures for Sambia, the next section will look at Haya.

### 6.3 Questions and relative clauses in Haya

In chapters 3 and 4, Haya and Sambia were compared in terms of their object marking patterns. Although the two languages showed many differences in their morphosyntax, it was argued that both languages have object agreement. Evidence to support this came from the fact that object-marked objects in Haya do not actually seem to be right-dislocated, as well as structural and word order parallels for object marking in the two languages. In *wh*-contexts the differences between Haya and Sambia are much more marked than elsewhere. In this section, I will briefly look at the structural properties of

questions in Haya and then discuss Haya object marking. For with regards to IAV and conjoint/disjoint effects, Haya shows roughly the same pattern as Sambiaa. However, the object marker patterns are entirely different, while Sambiaa sometimes requires object marking in *wh*-contexts, Haya bans it throughout.

### 6.3.1 Structure

In Haya, the conjoint/disjoint system is much more limited than in Sambiaa. Unlike in Sambiaa, Haya has several tenses which are neutral in terms of the conjoint/disjoint alternation. As introduced in chapter 3, a conjoint/disjoint distinction has been reported for only one tense in Haya (Hyman 1999). An example of this is shown in (56).

- (56) a. Y- a- kom- a Káto.  
SM1- PAST1.CJ- tie- FV 1Kato  
'He tied Kato.'
- b. Y- áá- mú- kôm- a.  
SM1- PAST1.DJ- OM1- tie- FV  
'He tied him.'
- [Haya, Hyman 1999:160]

Just like in Sambiaa and Zulu, the conjoint form must be used in *wh*-questions in Haya. The disjoint form is ungrammatical, as shown in (57).

- (57) a. Y- a- kom- a owa?  
SM1- PAST1.CJ- tie- FV who  
'Who did he tie?'
- b. \* Y- áá- kôm- a owa?  
SM1- PAST1.DJ- tie- FV who  
'Who did he tie?'
- [Haya]

However, unlike Sambiaa, Haya has multiple tenses which are neutral with regard to the conjoint/disjoint distinction. These are used in *wh*-questions but can also be used before a pause, as shown in (58).

- (58) a. A- ka- kom- a owa?  
SM1- PAST3- tie- FV who  
'Who did he tie?'
- b. A- ka- kom- a.  
SM1- PAST3- tie- FV  
'He tied.'
- [Haya]

As discussed in chapter 3, in Haya, unlike in Sambiaa, the word order of the direct and indirect object is flexible in non-questions, as shown in (59a) and (59b). This is not the case for the order of arguments and adjuncts, as shown with the example of 'the day before yesterday' in (59c) and (59d).

- (59) a. N- ka- gulira omwana ekitabo.  
SM1S- PAST3- buy 1child 7book  
'I bought the child a book.'

- b. N- ka gulira ekitabo omwana.  
SM1S- PAST3- buy 7book 1child  
'I bought the child a book.'
- c. N- ka- gulira omwana ekitabo ijo.  
SM1S- PAST3- buy 1child 7book day.before.yesterday  
'I bought the child a book yesterday.'
- d. \* N- ka gulira ijo ekitabo omwana.  
SM1S- PAST3- buy day.before.yesterday 7book 1child  
Int: 'I bought the child a book the day before yesterday.' [Haya]

However, when an adjunct is questioned it can appear immediately after the verb. This is shown in (60). As (60b) shows, the IAV effect is weak, because both orders are grammatical. However, if Haya had no IAV effects, the order where the temporal modifier precedes the object, as in (60a) would be entirely ungrammatical.

- (60) a. O- ka- gula maki ekitabo?  
SM2S- PAST3- buy when 7book  
'When did you buy the book?'
- b. O- ka- gula ekitabo maki?  
SM2S- PAST3- buy 7book when  
'When did you buy the book?' [Haya]

The data in (60b) shows that in Haya, as in Sambia, there are no crossing-over or postfocal effects with inanimates, while the word order in *wh*-questions appears to be much freer than in Sambia. However, we see the same basic word order pattern in both languages.

As in Sambia, subjects cannot be questioned in situ. This is shown in (61a). A cleft, as in (61b), or a reduced cleft, as in (61c), must be used.

- (61) a. \* Owai a- iz- ile?  
who SM1- come PAST2  
Int: 'Who came?'
- b. N' owai e- ya- iz- ile?  
COP who RM- SM1- come PAST2  
'Who came?'
- c. N' owai a- iz- ile?  
COP who SM1- come PAST2  
'Who came?' [Haya]

*Why*-questions are also formed as in Sambia, with a sentence-initial question word, as in (62).

- (62) Kuba ki o- ka- gula ekitabo?  
for what SM2S- PAST3- buy 7book  
'Why did you buy the book?' [Haya]

As in Smbaa, when an indirect object appears after the *wh*-word it must be object-marked, as shown in (63a). Without object marking, the sentence is ungrammatical, (63b). Object marking the direct object as well as the indirect object, as shown in (63c) is optional, though preferred.

- (63) a. O- ka- gulira omwana ekitabo maki?  
SM2S- PAST3- buy 1child 7book when  
'When did you buy the child a book?'
- b. \* O- ka- gulira maki omwana ekitabo?  
SM2S- PAST3- buy when 1child 7book  
Int: 'When did you buy the child a book?'
- c. O- ka- m- gulira maki omwana ekitabo?  
SM2S- PAST3- OM1- buy when 1child 7book  
'When did you buy the child a book?'
- d. O- ka- ki- m- gulira maki omwana ekitabo?  
SM2S- PAST3- OM7- OM1- buy when 1child 7book  
'When did you buy the child a book?' [Haya]

The behaviour of *wh*-questions is rather similar structurally to that in Smbaa. However, just like in non-questions, Haya allows more word order flexibility.

### 6.3.2 Object marking

In terms of object marking, Haya is very different from Smbaa. In Haya, object marking *wh*-elements is altogether ungrammatical. Unlike in Smbaa and Swahili, object marking a *who*-object is ungrammatical, as shown in (64).

- (64) W- a- (\*mu)- bona owa?  
SM2S- PAST1.CJ- OM1- see who  
'Who did you see?' [Haya]

In Haya, there is no difference between animate and inanimate objects in *wh*-questions. For all *wh*-elements, object marking is ungrammatical. This is shown in (65a). The non-questioned counterpart to (65a) is completely acceptable with object marking, as shown in (65b).

- (65) a. O- ka- (\*ki)- bona ki?  
SM2S- PAST3- OM7- see what  
'What did you see?'
- b. O- ka- ki- bona ekitabo.  
SM2S- PAST3- OM7- see 7book  
'You saw the book.' [Haya]

Likewise, in Haya relative clauses, object-marking a relativized object is ungrammatical, as shown for a noun referring to a human in (66). In Haya, relative clauses are marked with a demonstrative not with verbal morphology. This pattern is very common across Bantu.

- (66) Omuntu owo n- a- (\*mu)- letela eshokolate ...  
 1person 1DEM SM1S- PAST1- OM1- bring.APPL 9chocolate  
 ‘The person who I gave chocolate ...’ [Haya]

This holds even for non-restrictive relative clauses, where the head noun is interpreted as given, as shown in (67).

- (67) Juliette owo n- a- (\*mu)- ha- ile eshokolate n- a-  
 1Juliette 1DEM SM1- PAST1- OM1- GIVE- PAST2 1chocolate CONT- SM1-  
 ba- keisa.  
 OM2- greet  
 ‘Juliette, who I gave (the) chocolate, sends her greetings.’ [Haya]

Object marking is also ungrammatical for animate and inanimate *wh*-objects in Haya clefts, as shown in the examples in (68). Note that there is no overt copula in these constructions, but unlike other types of *wh*-questions, these questions have the relative morphology that is typical of Bantu clefts. In these examples, this is marked by the demonstrative *owo* and *ekyo* respectively.

- (68) a. Mwana ki owo w- a- boine?  
 1child what 1DEM SM2S- PAST1- see.PAST2  
 ‘Which child was it that you saw?’  
 b. \* Mwana ki owo w- a- mu- boine?  
 1child what 1DEM SM2S- PAST1- OM1- see.PAST2  
 Int: ‘Which child was it that you saw?’  
 c. Kintu ki ekyo w- a- boine?  
 7thing what 7DEM SM2S- PAST1- see.PAST2  
 ‘Which thing was it that you saw?’  
 d. \* Kintu ki ekyo w- a- ki- boine?  
 7thing what 7DEM SM2S- PAST1- OM7- see.PAST2  
 Int: ‘Which thing was it that you saw?’ [Haya]

Haya has a clear pattern with regard to the criterion used in Bresnan and Mchombo (1987). However, for the test suggested in Henderson (2006b) the results are contradictory because Haya would be an agreement language, because it allows an object-marked object to appear before a temporal adverbial, but it does not allow object marking in relative clauses.

Chichewa and Haya, as discussed in chapter 3, display a very similar tone pattern with object marking and a co-indexed lexical object (Bresnan and Mchombo 1987; Byarushengo et al. 1976). Moreover, like Haya, Chichewa never requires object marking with an overt object. However, Haya is different from Chichewa for relativization: object marking is allowed and sometimes required in relative clauses. In Henderson’s system, Chichewa counts also as an agreement language, while Bresnan and Mchombo (1987) argue it has pronominal object marking, based partially on the fact that Chichewa does not allow object marking in questions. Object marking in relative clauses is illustrated in (69). In (69a) the object-marked variant is shown. The degraded version, without object marking, is shown in (69b).

- (69) a. Njovu ziméné anyaní a- ku- zi- patsa mikánda zí-  
 10elephants 10.REL 2baboons SM2- PAST- OM10- give 4beads SM10-  
 ma- dyá nzímbe.  
 HAB- eat 10sugar.cane  
 ‘The elephants, that the baboons are giving beads to, eat sugar cane.’  
 [Chichewa, Mchombo 2004:41, commas added in translation]
- b. ??Njovu ziméné anyaní a- ku- patsa mikánda zí- ma-  
 10elephants 10.REL 2baboons SM2- PAST- give 4beads SM10- HAB-  
 dyá nzímbe.  
 eat 10sugar.cane  
 ‘The elephants, that the baboons are giving beads to, eat sugar cane.’  
 [Chichewa, Mchombo 2004:41, commas added in translation]

In Swahili, relative clauses pattern like questions and assertions, while in Sambia, relative clauses pattern like non-relativized assertions, not like questions. In Haya, relative clauses pattern like questions. Furthermore, Haya and Chichewa have the same pattern for assertions and questions but a different pattern for relative clauses. The fact that Chichewa and Haya pattern together for some *wh*-questions but not relative clauses, while Swahili and Sambia pattern together for relative clauses but not consistently for questions shows that a grouping based on the pronominal or agreement-like properties of object marking in a Bantu language cannot be linked to a particular pattern in relative clauses or *wh*-questions.

For Haya, Duranti (1977) argues that not allowing object marking in relative clauses is evidence for the pronominal status of the object marker. He has two pieces of evidence for this: the tone patterns discussed in section 3.3.3 and the relative clause data. Because Haya and Chichewa share the other property, which Duranti uses to decide that Haya is a pronominal object marking language, this generalization is already flawed. Moreover, there are languages which appear to fit the criteria for agreement but, like Haya, do not allow object marking in relative clauses. An example of this is Bemba (Marten et al. 2007). Bemba has different properties from Haya for object marking. It is asymmetric for passivization, word order and object marking, and allows only one object marker (with the exception of the first person singular in some cases). Bemba also allows doubling of the object marker and the object in normal affirmative clauses, which does not trigger any tone changes, as shown in (70) (Marten et al. 2007).

- (70) a. N- áli- mú- món- à Chìsángá.  
 SM1S- PAST- OM1- see- FV 1Chisanga  
 ‘I saw Chisanga.’ [Bemba, Marten et al. 2007:261]
- b. N- áli- món- à Chìsángá.  
 SM1S- PAST- see- FV 1Chisanga  
 ‘I saw Chisanga.’ [Bemba, Marten et al. 2007:262]

Bemba could therefore potentially be treated as an object agreement language. Bemba does not allow object marking in relative clauses, as shown in (71).

- (71) a. ìcí- pùnà ícò ùmù- ánakàshì á- mwèènè  
 7- chair REL7 1- girl SM1- see.PERF  
 ‘the chair which the girl saw...’ [Bemba, Marten et al. 2007:294]
- b. \* ìcí- pùnà ícò ùmù- ánakàshì á- cì- mwèènè  
 7- chair REL7 1- girl SM1- OM7- see.PERF  
 Int: ‘the chair which the girl saw...’ [Bemba, Marten et al. 2007:294]

We have seen that there is no clear correlation between the patterns in relative clause and questions and what looks like object agreement elsewhere. This brings us back to considering the role certain features of the object might play in object marking. This is discussed in the next section.

### 6.3.3 Definiteness and specificity

In chapter 3, it was shown that in (Kiunguja) Swahili and Sambia NPIs can be object-marked. In Haya, this is not the case. An inherently definite object noun phrase can receive a definite reading without object marking, as in (72).

- (72) N- ka- gula ekitabò kya omwana.  
 SM1S- PAST3- buy 7book 7ASSOC 1child  
 ‘I bought the child’s book (lit. the book of the child).’ [Haya]

It is difficult to test whether all object-marked objects must be definite or specific in Haya. However, in negative clauses the evidence is quite clear. In Haya, it is impossible to get the NPI reading with object marking. A sentence with an NPI reading and without object marking is shown in (18a). The augment does not appear in this context. The augment has been linked to definiteness but the relationship is not one to one. As in many Bantu languages, the augment is not used in NPI contexts in Haya. Object marking without the augment is generally ungrammatical, as shown in (18b). With an object marker only the definite reading is available, as shown in (18c). With object marking and *kyona kyona* ‘any’ the sentence is ungrammatical, as shown in (18d).

- (73) a. Ti- n- a- bona kintu kyonakyona.  
 NEG- SM1S- PAST1- see 7thing 7any  
 ‘I didn’t see anything.’ [Haya]
- b. \* Ti- n- a- ki- bona kintu.  
 NEG- SM1S- PAST1- OM7- see 7thing  
 \* ‘I didn’t see anything.’ [Haya]
- c. Ti- n- a- ki- bona ekintu.  
 NEG- SM1S- PAST1- OM7- see 7thing  
 \* ‘I didn’t see anything.’  
 ✓ ‘I didn’t see the thing.’ [Haya]
- d. \* Ti- n- a- ki- bona (kintu) kyonakyona.  
 NEG- SM1S- PAST1- OM7- see 7thing 7any  
 Int: ‘I didn’t see anything.’ [Haya]

The data introduced in this section shows that object-marked nouns in Haya cannot have a non-specific indefinite interpretation. This is not the case in Smbaa and Swahili, where object-marked nouns can have a non-specific interpretation. Since *wh*-elements are typically non-specific and indefinite, the ungrammaticality of object marking of *wh*-objects in Haya may be caused by a feature incompatibility.

## 6.4 Conclusions

In Haya, object marking is incompatible with objects interpreted as indefinite or non-specific and can therefore never appear in *wh*-questions. Cross-linguistically this fits into a widespread pattern of associating specificity with case marking and agreement. However, it is less clear why object marking is ungrammatical in relative clauses as well. Haya would be a language with pronominal object marking according to both Henderson (2006b) and Bresnan and Mchombo (1987) for the data in *wh*-contexts. However, for Henderson (2006b), Haya would count as a language which allows doubling and therefore be predicted to allow object marking in relative clauses. This means that Haya is a counterexample for the correlation drawn in Henderson (2006b) between doubling and the acceptability of object marking in relative clauses. As we have seen, neither test is conclusive in isolation.

Swahili generally allows object marking in *wh*-contexts. But although the acceptability of object marking for inanimate objects is different in questions, the same features trigger the same object marking patterns as in non-*wh*-contexts. In Smbaa, *wh*-questions differ from other relative clauses and non-*wh*-contexts for object marking. The animacy hierarchy applies more strictly in *wh*-environments than in other environments. In non-*wh*-environments, the hierarchy only works in one direction: to force object marking. In *wh*-environments, the hierarchy is bidirectional: it requires it at one end and bans it at the other end. In non-questions, several properties are relevant, namely, definiteness/referentiality<sup>6</sup> and animacy, whereas in questions only animacy matters. The definiteness hierarchy only appears to affect human objects as a subgroup in Smbaa.

Although relative clauses and cleft-questions involve the same morphology, they have different object marking patterns in Haya and Smbaa. Since inanimate objects pattern the same way in Smbaa and Haya questions, it is unlikely that this is caused by an agreement/pronoun distinction, but rather due to their featural composition and syntax. In both Smbaa and Haya, *wh*-questions have a particular object marking pattern. As the examples of Smbaa and Chichewa show, at least in some Bantu languages, the different types of *wh*-environments do not have the same properties for object marking. Based on these facts, the acceptability of object marking in questions cannot be used as a diagnostic for agreement-like or pronominal object marking, as proposed in Bresnan and Mchombo (1987) and Duranti (1979).

The final chapter discusses object marking in coordination structures.

---

<sup>6</sup>Proper names and first/second person are part of the definiteness scale introduced in chapter 3, based on Croft (2003).



## CHAPTER 7

---

### Object marking and coordination

---

In chapters 3 to 6, the behaviour of object marking across a range of construction types in Sambia, and Bantu more generally, has been discussed. This chapter deals with the agreement patterns which are found with coordinate structures. There are two general agreement patterns for coordinate structures: full agreement and partial agreement. Full agreement is agreement with the entire coordination phrase, while partial agreement is agreement with one of the conjuncts. Full agreement does not mean that all features will be reflected in the agreement morphology but rather that the entire CoP is agreed with, rather than a subpart.

Here, agreement with the first conjunct will be referred to as “first conjunct agreement” (FCA) and agreement with the second conjunct will be referred to as “second conjunct agreement” (SCA).

Within Bantu linguistics, coordinated noun phrases with conjuncts belonging to different noun classes and the agreement patterns they trigger were a popular topic during the 1970s and 80s. Most of this literature deals with subjects in one particular language, but there are several papers which provide a more general overview including Givón (1970), Bokamba (1985) and Katamba (2003). The following subject and object marking patterns with conjoined noun phrases in Bantu are reported (Kageyama 1977; Marten 2000, 2005; Marten and Ramadhani 2001; Nash 1992; Tak and Botne 1998):

- plural agreement (if both conjuncts belong to the same noun class)
- first conjunct agreement (FCA)
- second conjunct agreement (SCA)<sup>1</sup>

---

<sup>1</sup>SCA means agreement with the last conjunct, which in a coordination structure with two elements is the second one.

- agreement with a default plural noun class
- no agreement

First and second conjunct are instances of partial agreement, while default and plural agreement are instances of full agreement. Second conjunct agreement is much more rare than first conjunct agreement and has only been described as a possibility for subject marking – for example in Swahili (Bokamba 1985; Marten 2000), Luguru (Marten and Ramadhani 2001) or Dzamba (Bokamba 1985) – not for object marking. The most commonly mentioned default class is class 8. Class 10 seems to be less common. Schadeberg (1992) notes class 10 as a strategy accepted by some speakers of Swahili. In Zulu, class 17 is used (Buell 2009a; Nyembezi 1990). For coordination phrases containing human conjuncts, class 2 is used. This is sometimes extended to other animates, such as animals, even in languages where animals are generally not in class 1/2. In Swahili and Luguru, there is a difference between animates and inanimate noun phrases with regard to allowing partial agreement (Marten 2000; Marten and Ramadhani 2001).

There is an extensive literature on the syntax of coordinate structures in the languages of the world, some of this literature discusses agreement patterns, including Corbett (2006), Johannessen (1998) and van Koppen (2005). Corbett (2006) argues that coordinate structures are problematic for agreement systems because they can be built from elements which are singular but are part of a syntactic structure which is plural. Corbett refers to these configurations as mismatches between the meaning and the form. Coordinated plural elements do not create this kind of mismatch, since all elements are plural. However, in languages with gender distinctions, for example the Bantu noun class system, coordinate structures with nouns belonging to different genders produce mismatches. Cross-linguistically, in such situations, coordinated DPs typically allow either plural or singular agreement. From a typological perspective, Corbett argues that agreement tends to be with the nearest conjunct, citing a number of languages which allow agreement with the second conjunct. His examples for second conjunct agreement come from Swahili subject coordination.

From a Generative syntax perspective, second conjunct agreement is problematic. This is because in the standard Generative analysis of coordination,<sup>2</sup> as shown in (1), the second conjunct (DP2) is the complement of the coordination phrase and is more deeply embedded than the first conjunct (DP1) in the specifier position of CoP. For a range of syntactic constructions, it is assumed that the specifier position of a phrase remains visible to syntax but not its other constituents.

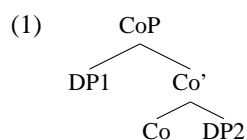

<sup>2</sup>See Borsley (2005) for arguments against the standard analysis.

Johannessen (1998) proposes an additional structure. As well as the structure in (1), she proposes a second structure where the specifier is merged to the right and the CoP is head-final, shown in (2).

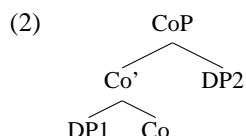

This means that the second conjunct is in the specifier of CoP, while the first conjunct is the most deeply embedded, as the complement of Co. She argues that which structure a language has depends on whether it is head-final or head-initial, particularly with regard to the order of the verb and the object. She argues that OV languages have the specifier on the right, while VO languages have the specifier on the left (Johannessen 1998:55).

Beyond the question of accessibility, the coordinate structure agreement patterns discussed here pose a problem for syntactic theory because agreement is optionally with one conjunct or with the entire phrase. A similar pattern in Dutch dialects is discussed in van Koppen (2005).

For the purposes of distinguishing agreement from pronominal incorporation, coordination structures provide further evidence. Pronominal incorporation of one conjunct would be ruled out under the Coordinate Structure Constraint (Ross 1967), which rules out moving one conjunct out of a coordination phrase. Incorporated pronouns would either have to “agree” with both conjuncts or with the entire CoP. However, as shown in this chapter, in all languages under discussion, agreement with one conjunct is possible, while agreement with both conjuncts is ungrammatical.

If the object marker were to be analysed as an anaphoric pronoun, on the other hand, it would not need to have syntactic access (locality as defined by *c*-command) to its co-referential DP at all. This ought to allow for free co-indexing between the object marker and any conjunct. However, in all of the languages considered here, there are no environments where either FCA or SCA would be possible. The choice, where there is optionality, is always between one particular conjunct and the entire CoP.

For object agreement, as argued for in this thesis, syntactic access is necessary, while movement is not. This fits the patterns described here. However, as will be discussed further below, the coordination structure data is problematic for the theory of agreement proposed in chapter 4. If agreement is determined by closest *c*-command alone, we would predict only the features of the entire coordination phrase (CoP) to be able to be object-marked. This is illustrated with the tree diagram in (3). In this structure, the Probe AgrO finds the CoP first and can agree with it, but agreement with DP1 and DP2 would be ruled since CoP is closer to the Probe. The structure represented here corresponds to a direct object in the complement position of V. However, a specifier in the subject position (subject) or a specifier of V (indirect object) would have the same embedding structure and therefore behave in the same way.

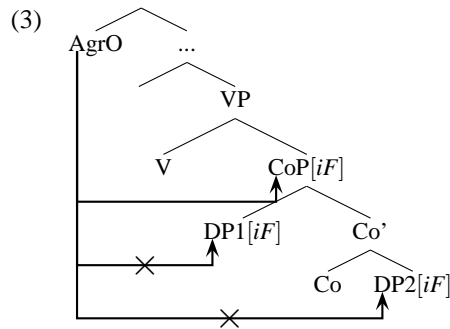

However, the agreement pattern predicted by closest c-command is not the pattern that we generally find with objects or subjects in situ in Sambia. As shown in this chapter, first conjunct agreement is possible in certain environments, where full agreement is also possible. When the relative order of the verb and its arguments is taken into account, the following descriptive generalizations can be made:

- Subject marking and object marking pattern in the same way for coordination agreement.
- Agreement is affected by the position of the coordinate structure with regard to the verb (see also Marten 2000, 2005).
- Semantic hierarchies do not affect coordination agreement in Sambia.
- Coordination affects agreement patterns for objects in terms of obligatory agreement.

In this chapter, agreement patterns with coordinate structures are discussed. The relevant data includes both subject marking and object marking. Section 7.1 introduces the Agree mechanism for FCA and full agreement as argued for in van Koppen (2005). The subsequent sections discuss the Sambia data in detail. Section 7.6 discusses the patterns found in Haya. Finally, 7.7 discusses the implications of the data introduced in the chapter for the approach to syntactic agreement argued for in this thesis.

## 7.1 Coordination agreement

Van Koppen (2005) discusses agreement patterns in Dutch dialects, where there are two potential Goals for each Probe. As she argues, a Probe finding a coordinate structure as its Goal will see two equally local Goals. Those are the CoP and the first conjunct, but not the second conjunct. This is based on the structure illustrated in (4).

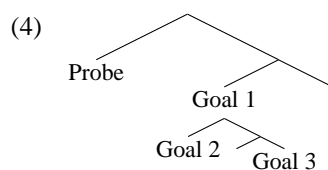

If we use Agree as defined in Chapter 4, Goal 1 will be more local than Goal 2. Based on this, we would predict that in a language like Sambia, where agreement is strictly local, FCA should be ungrammatical. Only full agreement should be possible. If Agree works the way it does in Haya, using Equidistance, both FCA and SCA would be predicted to be grammatical. Van Koppen (2005) does not use Equidistance, but derives the appropriate visibility by creating the concept of “Equally local”:

- (5) Equally local  
Y and Z are equally local to X iff, (i) X c-commands both Y and Z (ii) the set of nodes that c-command Y is identical to the set of nodes that c-command Z.

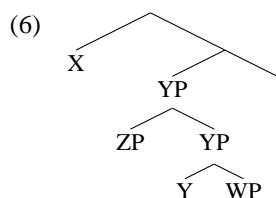

If one uses a standard definition of c-command, as stated in (7), the first conjunct (ZP in (6)) would be in a mutual c-command relation with the lower YP, but CoP (the highest projection of YP) would not be c-commanded by ZP. Therefore, YP and ZP would not be equally local.

- (7) C-command (standard):  
X c-commands Y iff, the first nodes that dominates X, also dominates Y.

Van Koppen (2005) proposes a modified definition of c-command, which is shown in (8).

- (8) C-command (van Koppen 2005):  
X c-commands Y iff, (i) X excludes Y (X excludes Y if no segment of X dominates Y.) (ii) the first nodes that dominates X, also dominates Y.

In this definition, YP is a segment of YP but not a segment of Y. This allows for a head to c-command its complement (thus allowing for Agree to take place at all), but it does not allow the lower YP projection to c-command the specifier of YP, that is ZP. It furthermore allows Y to c-command WP, making WP not equally local. Adopting this definition enables us to account for FCA without changing the way Agree works in Sambia.

## 7.2 Object marking in coordinate structures

Of the subject/object marking patterns with coordinated noun phrases listed above, Sambia make use of four strategies: no agreement, first conjunct agreement (FCA),

plural agreement or class 8, the default class. Which strategy is used depends on the properties of the conjuncts.

When non-human but animate objects of the same noun class are coordinated, three of these strategies are possible. This is shown for no agreement in (9a), for partial agreement (here one cannot see whether it is the first or the second conjunct) in (9b) and for class 10, the plural of class 9, in (9c).<sup>3</sup>

- (9) a. N-    za-       ona shimba na shui.  
SM1S- PERF.DJ- see 9lion and 9leopard  
'I saw the lion and the leopard.'
- b. N-    za-       i-     ona shimba na shui.  
SM1S- PERF.DJ- OM9- see 9lion and 9leopard  
'I saw the lion and the leopard.'
- c. N-    za-       zi-     ona shimba na shui.  
SM1S- PERF.DJ- OM10- see 9lion and 9leopard  
'I saw the lion and the leopard.'
- [Sambaa]

The same patterns are possible when two human objects are coordinated: no agreement, in (10a), first conjunct agreement, in (10b), and plural agreement, in (10c).

- (10) a. N-    za-       ona mwaimu na ng'wana.  
SM1S- PERF.DJ- see 1teacher and 1child  
'I saw the teacher and the child.'
- b. N-    za-       mw-    ona mwaimu na ng'wana.  
SM1S- PERF.DJ- OM1- see 1teacher and 1child  
'I saw the teacher and the child.'
- c. N-    za-       wa-     ona mwaimu na ng'wana.  
SM1S- PERF.DJ- OM2- see 1teacher and 1child  
'I saw the teacher and the child.'
- [Sambaa]

Where both nouns belong to the same noun class, it is not clear whether any singular agreement is first conjunct agreement, rather than second conjunct agreement. However, where two coordinated nouns belong to different noun classes the distinction becomes clear. FCA and plural agreement are possible, as shown in (11a), while second conjunct agreement (SCA) is ungrammatical, as shown in (11b). The plural of either noun class is also ungrammatical, as shown in (11c) and (11d). The default class can be used, as shown in (11e). However, when both nouns are animate, animate agreement, that is class 2, is often preferred, as illustrated in (11f).

- (11) a. N-    za-       ji-     ona kui na shimba.  
SM1S- PERF.DJ- OM5- see 5dog and 9lion  
'I saw the dog and the lion.'

<sup>3</sup>The way the nominal classes in Bantu work in general, in terms of singular plural pairings, and the list of the noun classes in Sambaa are explained on page 20.

- b. \* N- za- i- ona kui na shimba.  
SM1S- PERF.DJ- OM9- see 5dog and 9lion  
Int: 'I saw the dog and the lion.'
- c. \* N- za- ya- ona kui na shimba.  
SM1S- PERF.DJ- OM6- see 5dog and 9lion  
Int: 'I saw the dog and the lion.'
- d. \* N- za- zi- ona kui na shimba.  
SM1S- PERF.DJ- OM10- see 5dog and 9lion  
Int: 'I saw the dog and the lion.'
- e. N- za- vi- ona kui na shimba.  
SM1S- PERF.DJ- OM8- see 5dog and 9lion  
'I saw the dog and the lion.'
- f. N- za- wa- ona kui na shimba.  
SM1S- PERF.DJ- OM2- see 5dog and 9lion  
'I saw the dog and the lion.'

[Sambaa]

The same pattern holds when the order of the nouns is reversed, again FCA is grammatical, as shown in (12a), while SCA is ungrammatical, as shown in (12b). Default object marking is also possible, as shown in (12c).

- (12) a. N- za- i- ona shimba na kui.  
SM1S- PERF.DJ- OM9- see 9lion and 5dog  
'I saw the lion and the dog.'
- b. \* N- za- ji- ona shimba na kui.  
SM1S- PERF.DJ- OM5- see 9lion and 5dog  
Int: 'I saw the lion and the dog.'
- c. N- za- vi- ona shimba na kui.  
SM1S- PERF.DJ- OM8- see 9lion and 5dog  
'I saw the lion and the dog.'

[Sambaa]

It is never possible to agree with both conjuncts, as shown in (13).

- (13) a. \* N- za- i- ji- ona kui na shimba.  
SM1S- PERF- OM9- OM5- see 5dog and 9lion  
'I saw the dog and the lion.'
- b. \* N- za- ji- i- ona kui na shimba.  
SM1S- PERF- OM5- OM9- see 5dog and 9lion  
'I saw the dog and the lion.'

[Sambaa]

This is not surprising in terms of agreement since, as shown in chapters 3 and 4, object agreement is dependent on the position and syntactic status of the object (as indirect object, direct object or locative), and since each position can only be filled once, it is expected that only one object marker corresponds to it. However, this data is evidence against the pronoun incorporation analysis since this moving both elements would be the only kind of movement (Across the Board Movement) which would be

allowed from inside a coordinate structure, without violating the Coordinate Structure Constraint.

The pattern does not change when two nouns of a very different animacy status are coordinated, for example with a proper name and an inanimate object, as shown in (14). Even if the human object is the second conjunct, object marking is only grammatical with the inanimate object, as shown in (14a), while agreement with the human object is ungrammatical as shown in (14b).

- (14) a. N-    za-       ji-    ona iwe   na Joni.  
           SM1S- PERF.DJ- OM5- see 5stone and 1John  
           ‘I saw the stone and John.’
- b. \* N-    za-       mw-   ona iwe   na Joni.  
           SM1S- PERF.DJ- OM1- see 5stone and 1John  
           Int: ‘I saw the stone and John.’ [Sambaa]

If a first person singular and a third person singular pronoun are coordinated, FCA or plural agreement is also maintained. In feature hierarchies (Aissen 2003; Duranti 1979) (as discussed in chapter 3 and elsewhere in this thesis) second person ranks above third person, animate above inanimate and definite above indefinite, but these do not affect the agreement pattern for coordinate structures. This is shown in (15). If the third person pronoun (in Sambaa the demonstratives of class 1/2 are used as third person singular and plural pronouns) precedes, class 1 agreement is possible, as shown in (15a).<sup>4</sup> Class 2 agreement is also possible, as shown in (15b). Whereas, second person singular agreement is ungrammatical, as shown in (15c).

- (15) a. Juma a-    za-       mw-   ona uja   na iwe.  
           1Juma SM1S- PERF.DJ- OM1- see 1DEM and you.SG  
           ‘Juma saw him and you.’
- b. Juma a-    za-       wa-   ona uja   na iwe.  
           1Juma SM1S- PERF.DJ- OM2- see 1DEM and you.SG  
           ‘Juma saw him and you.’
- c. \* Juma a-    za-       ku-   ona uja   na iwe.  
           1Juma SM1S- PERF.DJ- OM2S- see 1DEM and you.SG  
           Int: ‘Juma saw him and you.’ [Sambaa]

If the second person pronoun precedes, object marking can be second person singular as shown in (16a) or second person plural as shown in (16b) but not class 1 (third person singular), as shown in (16c).

- (16) a. Juma a-    za-       ku-   ona iwe   na uja.  
           1Juma SM1- PERF.DJ- OM2S- see you.SG and 1DEM  
           ‘Juma saw you and him.’

<sup>4</sup>Class 1 corresponds to third person singular for animates, while class 2 corresponds to third person plural for animates.

- b. Juma a- za- mi- ona iwe na uja.  
 1Juma SM1- PERF.DJ- OM2P- see you.SG and 1DEM  
 ‘Juma saw you and him.’
- c. \* Juma a- za- mw- ona iwe na uja.  
 1Juma SM1- PERF.DJ- OM1- see you.SG and 1DEM  
 Int: ‘Juma saw you and him.’ [Sambaa]

The data in this section have shown that in order to be able to trigger object marking, the object must be the first conjunct. Animacy or person hierarchies are less important than thematic role and the order of the complements in a coordinate structure in determining object marking patterns in Sambaa.

### 7.3 Subject marking in coordinate structures

Subject marking for coordinated subjects where the conjuncts belong to different noun classes only allows two agreement patterns: plural and default agreement. Neither first nor second conjunct agreement is possible. This is shown for FCA in (17a) and for SCA in (17b).

- (17) a. \* Shimba na kui i- i- laliye.  
 9lion and 5dog SM9- PERF.DJ- sleep.PERF.CJ  
 Int: ‘The lion and the dog slept.’ (disjoint)
- b. \* Shimba na kui ji- i- laliye.  
 9lion and 5dog SM5- PERF.DJ- sleep.PERF.CJ  
 Int: ‘The lion and the dog slept.’ (disjoint) [Sambaa]

Agreement with class 8, that is, default agreement, is illustrated in (18a). With coordinated nouns that refer to non-human animates, namely animal terms, agreement with class 2, as shown in (18b), is preferred to agreement with class 8. Class 2, then, functions as a second default class for non-human animates. Note that this is in clear contrast to the pattern with non-coordinated animal terms, as discussed on 47, where class 1/2 agreement is ungrammatical.

- (18) a. Shimba na kui vi- i- laliye.  
 9lion and 5dog SM8- PERF.DJ- sleep.PERF.CJ  
 ‘The lion and the dog slept.’ (disjoint)
- b. Shimba na kui wa- i- laliye.  
 9lion and 5dog SM2- PERF.DJ- sleep.PERF.CJ  
 ‘The lion and the dog slept.’ (disjoint) [Sambaa]

In elicitation, sentences such as (18) were produced, with a preference for the pattern in (18b). However, Bantu language speakers are often uncomfortable with such constructions, particularly for animates in languages where words for animal terms do not take class 1/2 agreement. In natural speech, both class 2 and class 8 are also used but they are used somewhat differently. Both patterns can be used in the same utterance

by the same speaker. This is shown in (19). There seems to be a tendency for class 8 to be used with the lexical noun, while class 2 is used “anaphorically” (co-indexed with an entity that is present in the discourse). Since these constructions are not very common, my corpus of spoken Sambia does not include enough examples to establish this pattern with certainty. Nevertheless, several speakers, whose utterances are included in my corpus, used the pattern illustrated here.

- (19) Uja ng'wana na jia kui vi- te- ikaa du mja mwe  
 1DEM 1child and 5DEM dog SM8- NPST.DJ- sit only 18DEM 18LOC  
 mazi. [...] Miya ushe mja mwe mazi wa- aa- tegheza mna  
 6water but now 18DEM 18LOC water SM2- PRES.DJ- listen 18having  
 vuzo vuzo.  
 10noise  
 ‘The child and the dog just sit there in the water. [...] But now, there in the  
 water, they are listening, there is noise.’ [Sambia]

Note that the agreement pattern is affected by whether or not the CoP is syntactically expressed. This is evidence against an analysis of object marking as being “anaphoric” in general, in this language.

Sambia has only one strategy for subject marking with coordinated noun phrases in the subject position, namely full agreement with the appropriate default class, dependent on the animacy status of both conjuncts. Thus, it looks as if there was a difference between how objects and subjects behave for agreement conflict resolutions. However, as shown in the next section this difference disappears once the relative order of the coordination phrase and the verb is taken into account.

## 7.4 Comparing pre- and postverbal coordinate NPs

The apparent difference between subjects and objects disappears when one allows for word order alternations. In SVO, the basic word order of most Bantu languages (Bearth 2003), subjects are preverbal while objects are postverbal. However, objects can be topicalized and subjects can appear postverbally either as in situ subjects or right-dislocated elements. In contrast to the pattern described in section (7.3) for preverbal subjects, postverbal subjects allow FCA, as shown in (20a). SCA is ungrammatical, (20b). Plural agreement is also grammatical either with the default class, as in (20c), or, in the case of animates, also with class 2, as in (20d).

- (20) a. I- i- laliye shimba na kui.  
 SM9- PRF.DJ- sleep.PERF.CJ 9lion and 5dog  
 ‘The lion and the dog slept.’ (disjoint)
- b. \* Ji- i- laliye shimba na kui.  
 SM5- PRF.DJ- sleep.PERF.CJ 9lion and 5dog  
 Int: ‘The lion and the dog slept.’ (disjoint)

- c. Vi- i- laliye shimba na kui.  
SM8- PRF.DJ- sleep.PERF.CJ 9lion and 5dog  
'The lion and the dog slept.' (disjoint)
- d. Wa- i- laliye shimba na kui.  
SM2- PRF.DJ- sleep.PERF.CJ 9lion and 5dog  
'The lion and the dog slept.' (disjoint) [Sambaa]

When the object appears in preverbal position, for example with topicalized objects, plural agreement is required, as shown in (21a). FCA is ungrammatical, as shown in (21b). In the corresponding sentence where the object is not topicalized FCA is grammatical, as shown in (21c).

- (21) a. Imi na wana, Juma a- za- ti- etea mazi.  
me and 2children 1Juma SM1- PERF.DJ- OM1P- bring.APPL 6water  
'Me and the children, Juma brought us water.'
- b. \* Imi na wana, Juma a- za- ni- etea mazi.  
me and 2children 1Juma SM1- PERF.DJ- OM1S- bring.APPL 6water  
'Me and the children, Juma brought us water.'
- c. Juma a- za- ni- etea mazi imi na wana.  
1Juma SM1- PERF.DJ- OM1S- bring.APPL 6water me and 2children  
'Juma brought me and the children water.' [Sambaa]

Agreement with postverbal and preverbal conjunct NPs in Sambaa is summarized in the table in (7.1).

Table 7.1: Agreement with conjoint NPs

	postverbal	preverbal
object	FCA or plural/default	plural/default
subject	FCA or plural/default	plural/default

For both subjects and objects, FCA is grammatical when they appear postverbally. In contrast, neither subjects nor objects allow FCA when they appear preverbally. Both allow plural agreement.

## 7.5 Coordination and obligatory agreement

Coordination affects whether or not agreement is obligatory for objects. When two nouns which trigger obligatory object agreement are coordinated, object marking is optional. Recall that object marking is obligatory with proper names, as illustrated in (22).

- (22) Ni- ta- \*(m)- dikiya Martini.  
SM1S- PRES.DJ- OM1- cook.APPL 1Martin  
'I cook for Martin.' [Sambaa]

But when two proper names are coordinated, object marking is optional. Either full agreement or FCA are grammatical, as shown in (23a) and (23b) respectively.

- (23) a. Ni- ta- (wa)- dikiya Martini na Maria.  
SM1S- PRES.DJ- OM2- cook.APPL 1Martin and 1Maria  
'I cook for Martin and Maria.'
- b. Ni- ta- (m)- dikiya Martini na Maria.  
SM1S- PRES.DJ- OM1- cook.APPL 1Martin and 1Maria  
'I cook for Martin and Maria.'
- [Sambaa]

The same pattern is observed with other nouns which obligatorily trigger object agreement, such as kinship terms, as shown in (24).

- (24) N- za- (wa)- ona tate na mame na wau.  
SM1S- PERF.DJ- OM2- see my.father and my.mother and sister  
'I saw dad, mum and sister.'
- [Sambaa]

As discussed in chapter 6, in object *wh*-questions about humans, object marking is also obligatory in Sambaa, as shown in (25).

- (25) U- \*(mw)- ene ndayi?  
SM2S- OM1- see.PERF.CJ who  
'Who did you see?'
- [Sambaa]

In Sambaa, exhaustive list questions are formed by coordinating two *wh*-words. These pattern similarly to the nouns which trigger obligatory object marking due to their semantic features. FCA, shown in (26a), is grammatical, as is not having agreement, shown in (26b). However, unlike with non-*wh*-items, plural agreement is ungrammatical, as shown in (26c), even though there is no mismatch. This is particularly surprising because, as was shown in chapter 6, *ndayi* 'who' allows both singular and plural agreement on the verb.

- (26) a. U- mw- ene ndayi na ndayi?  
SM2S- OM1- see.PERF.CJ who and who  
'Who all did you see?'
- b. U- ene ndayi na ndayi?  
SM2S- see.PERF.CJ who and who  
'Who all did you see?'
- c. \* U- wa- ene ndayi na ndayi?  
SM2S- OM2- see.PERF.CJ who and who  
Int: 'Who all did you see?'
- [Sambaa]

In Sambaa, object marking is never obligatory with coordination structures. Although *wh*-items differ slightly from other objects, the same effect on obligatory agreement is observed.

## 7.6 Coordination in Haya

According to Kageyama (1977), in Haya, the default class for agreement with animates is class 2, while class 8 is used with coordinated inanimates of different noun classes. He proposes a hierarchy: human > animate > inanimate. In this system, the higher ranking element determines the shape of the agreement marker. In his data, shown in (27a), class 2 is used when a human and a non-human animate noun are coordinated, while class 10 (the plural of class 9) is ungrammatical, as shown in (27b).

- (27) a. Omushaija n' embwa ba- a- genda.  
 1man and 9dog SM2- PAST1- go  
 'The man and the dog went.' [Haya, Kageyama 1977:134]
- b. \* Omushaija n' embwa za- a- genda.  
 1man and 9dog SM10- PAST1- go  
 Int: 'The man and the child went.' [Haya, Kageyama 1977:134]

My data differs from this. With preverbal subject coordination of a human with a non-human animate, class 2 is ungrammatical, as illustrated in (28a). Only class 8 is acceptable. This is illustrated in (28b).

- (28) a. \* Ekihuka n' omushaija ba- ka- nagira.  
 7insect and 1man SM2- PAST3- sleep.  
 Int: 'The insect and the man slept.'
- b. Ekihuka n' omushaija bi- ka- nagira.  
 7insect and 1man SM8- PAST3- sleep.  
 'The insect and the man slept.' [Haya]

This pattern holds irrespective of the noun class the non-human belongs to. For example with *entare* 'lion', which is class 9/10, the same pattern holds: class 8 is acceptable while class 2 is ungrammatical. This is shown in (29a) and (29b).

- (29) a. Entare n' omushaija bi- ka- nagira.  
 9lion and 1man SM8- PAST3- sleep.  
 'The lion and the man slept.'
- b. \* Entare n' omushaija ba- ka- nagira.  
 9lion and 1man SM2- PAST3- sleep.  
 Int: 'The lion and the man slept.' [Haya]

When the coordinated subject appears in postverbal position, as in Sambia, FCA and default agreement are acceptable. SCA is never acceptable. This is shown for the order class 7 followed by class 9 in (30a) and (30b) and for class 9 followed by class 7 in (30c) and (30d). Default (class 8) agreement is shown in (30e).

- (30) a. Ki- ka- nagira ekihuka n' entale. (FCA)  
 SM7- PAST3- sleep 7insect and 9lion  
 '(There) slept the insect and the lion.'

- b. \* E- ka- nagira ekihuka n' entale. (SCA)  
SM9- PAST3- sleep 7insect and 9lion  
Int: '(There) slept the insect and the lion.'
- c. E- ka- nagira entale n' ekihuka. (FCA)  
SM9- PAST3- sleep 9lion and 7insect  
'(There) slept the insect and the lion.'
- d. \* Ki- ka- nagira entale n' ekihuka. (SCA)  
SM7- PAST3- sleep 9lion and 7insect  
Int: '(There) slept the insect and the lion.'
- e. Bi- ka- nagira ekihuka n' omushaija. (default)  
SM8- PAST3- sleep 7insect and 1man  
'(There) slept the insect and the man.' [Haya]

Although not discussed in the literature on Haya, we can assume that the standard analysis of Haya subject marking would be as agreement. Therefore, partial agreement with the coordination phrase is not unexpected.

Turning now to object marking, Kageyama (1977) further argues that, in Haya, objects of two different noun classes do not allow object agreement. My own Haya data shows a different pattern. Just like in Sambiaa, for both subjects and objects, FCA is grammatical with postverbal conjuncts, as shown in (31a), while plural or a default class are acceptable with preverbal elements. One difference between Haya and Sambiaa is that the default class, class 8, is less established grammatically. Occasionally it is rejected, as shown in the example in (31b). When the coordinated NP is topicalized, the default pattern is grammatical, as shown in (31c), while FCA is ungrammatical, as shown in (31d).

- (31) a. N- ka- li- gula eiuli n' omfuko. (postverbal, default)  
SM1S- PAST3- OM5- buy 5egg and 3bag  
'I bought the egg and the bag.'
- b. \* N- ka- bi- gula eiuli n' omfuko. (postverbal, FCA)  
SM1S- PAST3- OM8- buy 5egg and 3bag  
Int: 'I bought the egg and the bag.'
- c. Eiuli n' omfuko n- ka- bi- gula. (topicalized, default)  
5egg and 3bag SM1S- PAST3- OM8- buy  
'The egg and the bag, I bought them.'
- d. \* Eiuli n' omfuko n- ka- li- gula. (topicalized, FCA)  
5egg and 3bag SM1S- PAST3- OM8- buy  
Int: 'The egg and the bag, I bought them.' [Haya]

The same holds for humans when combined with non-humans. This is illustrated in (32a) and (32b).

- (32) a. A- ka- gi- bona embwa nanye. (postverbal, FCA)  
SM1- PAST3- OM9- see 9dog and.me  
'He saw the dog and me.'

- b. A- ka- m- bona inye n' embwa. (*postverbal, FCA*)  
 SM1- PAST3- OM1S- see me and 9dog  
 'He saw me and the dog.' [Haya]

The fact that agreement with one of the conjuncts is possible shows that Haya object marking, just like Sambia object marking, cannot be analysed as pronominal incorporation.

In my data, there is no evidence of any hierarchies affecting possible agreement patterns with conjoint noun phrases. Proper names, first and second person pronouns, and common nouns referring to humans all display the same pattern: agreement is determined by the order of the conjuncts and the position of the conjunct with regard to the verb. This is shown for proper names in (33a-c).

- (33) a. \*Kato na Kakulu a- ka- nagira. (*preverbal, FCA*)  
 1Kato and 1Kakulu SM1- PAST3- sleep  
 'Kato and Kakulu slept.'
- b. Kato na Kakulu ba- ka- nagira. (*preverbal, plural*)  
 1Kato and 1Kakulu SM2- PAST3- sleep  
 'Kato and Kakulu slept.'
- c. A- ka- nagira Kato na Kakulu. (*postverbal, FCA*)  
 SM1- PAST3- sleep 1Kato and 1Kakulu  
 '(There) slept Kato and Kakulu.' [Haya]

The pattern with a personal pronoun is illustrated in (34a) and (34b).

- (34) a. Inye na omukazi tu- ka- bona Kato. (*preverbal, plural*)  
 I and 1woman SM1P- PAST3- see 1Kato  
 'The woman and I saw Kato.'
- b. \* Inye na omukazi n- ka- bona Kato. (*preverbal, FCA*)  
 I and 1woman SM1S- PAST3- see 1Kato  
 Int: 'The woman and I saw Kato.' [Haya]

This section shows that agreement with coordinate structures follows the same patterns in Haya as in Sambia. Available strategies are default class agreement and first conjunct agreement with preverbal elements.

## 7.7 Swahili coordinate structures

Corbett (2006) cites Swahili as a language with second conjunct agreement. This is illustrated in (35) with data from Bokamba (1985). In (35a), the second conjunct is *mguu wa meza* 'table leg' which takes the class 3 gender feature of its head noun and determines the agreement on the verb. When the word order is reversed, again the subject agrees with the second conjunct, which is the class 7 noun *kiti* 'chair'.

- (35) a. kiti na mguu wa meza u- me- vunjika  
 7chair and 3leg 3ASSOC 9table SM3- PRF- break  
 'the chair and the leg of the table are broken'

- b. \* kiti na mguu wa meza ki- me- vunjika  
 7chair and 3leg 3ASSOC 9table SM7- PRF- break  
 ‘the chair and the leg of the table are broken’
- c. mguu wa meza na kiti ki- me- vunjika  
 3leg 3ASSOC 9table and 7chair SM7- PRF- break  
 ‘the leg of the table and the chair are broken’

[Swahili, Bokamba 1985:45]

Based on data from Bokamba (1985), Johannessen (1998) argues that Swahili coordination has the structure with the second conjunct in the specifier position, which was introduced in (2), and is repeated in (36). This would predict that second conjunct agreement would be possible for objects, and postverbal subjects as well as for preverbal subjects, while first conjunct agreement would be ungrammatical.

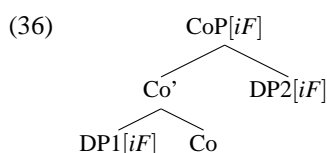

However, as van Koppen (2005) also notes, based on data from Marten (2000), Swahili allows first conjunct agreement with postverbal coordinate structures. This is illustrated in (37), where the agreement is with the postverbal subject.

- (37) ... a- li- mw- omba Bibie Shali na jamaa wote ...  
 SM1- PAST- OM1- beg 1Bibie.Shali and 9company 2all  
 ‘he asked [of] Bibie Shali and the whole company...’

[Swahili, Marten 2000:87]

Cross-linguistically, as Corbett points out, while there are languages which allow agreement with a distant first conjunct (the first conjunct in a preverbal coordinate structure), there are no languages which allow agreement with a distant second conjunct (the second conjunct in a postverbal coordinate structure) (Corbett 2006:170). In Swahili, second conjunct agreement is only possible with preverbal subjects, not with postverbal subjects or objects. Moreover, as Marten (2000, 2005) shows, second conjunct agreement is also restricted to inanimate nouns in Swahili, while first conjunct agreement is less restricted. A lot of variation is reported for coordinate structure agreement in Swahili, and not all Swahili speakers allow second conjunct agreement. Second conjunct agreement is a rather marginal pattern in Swahili, while for the most part Swahili behaves like Sambia and Haya. Just like Sambia and Haya, Swahili allows first conjunct agreement with postverbal subjects and objects of any kind, but not with preverbal subjects.

Johannessen derives the structure in (36) from the word order of Swahili, which she claims to be SOV. This claim is taken from Bright (1992), where there appears to be a mistake, because, while Bright claims that the basic word order is subject

object verb, none of the examples presented match this order. All examples shown are SVO. In fact, Swahili, like the vast majority of the Bantu languages, has SVO word order, and therefore should not allow SCA, according to Johannessen's analysis. Even if one were to assume that Bantu languages have underlying SOV (analysing the object marker as the object), this assumption would lead to the prediction that Bantu languages generally allow SCA but not FCA. In fact, the opposite holds: FCA is widespread in Bantu, while SCA is very rare, with Swahili and Ndebele (Corbett 2006) as only well-known examples.

Beyond the objection regarding the grammaticality of FCA in Swahili, as raised in van Koppen (2005), Johannessen's analysis also fails to account for the fact that FCA or SCA agreement are one option for agreement with particular word orders but that they are never the only option in the languages under discussion here. In her model, the conjunct which is in the specifier position enters a spec-head agreement relation with the head of the CoP. This transfers the features of the DP2 to the Co head and then from the head to its maximal projection (CoP). This is illustrated in (38).

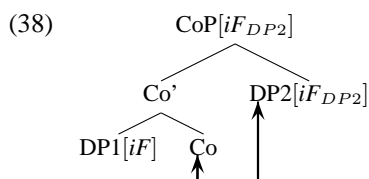

Her analysis only allows for the CoP to have the features of one conjunct, namely of the conjunct which appears in the specifier position of CoP. The CoP cannot have its own set of features. However, the data from Bantu does not support such an analysis. Recall that in coordination structures, such as the one in (39a) and (39b), repeated from (11), both default agreement and FCA are grammatical. The fact that there is a default gender form in (39b), indicates that the CoP does not have a gender feature. Whereas using the plural form of class 5, namely class 6, is ungrammatical, as shown in (39b).

- (39) a. N-    za-       ji-    ona kui   na shimba.  
SM1S- PERF.DJ- OM5- see 5dog and 9lion  
'I saw the dog and the lion.'
- b. N-    za-       vi-    ona kui   na shimba.  
SM1S- PERF.DJ- OM8- see 5dog and 9lion  
'I saw the dog and the lion.'
- c. \* N-    za-       ya-    ona kui   na shimba.  
SM1S- PERF.DJ- OM6- see 5dog and 9lion  
Int: 'I saw the dog and the lion.'
- d. Ni-    ta-       (wa)- dikiya    Martini na Maria.  
SM1S- PRES.DJ- OM2- cook.APPL 1Martin and 1Maria  
'I cook for Martin and Maria.'
- [Sambaa]

Furthermore, as discussed in section 7.5, (39d, repeated from 23), coordinate structures containing DPs that trigger obligatory agreement when they are not coordinated

do not trigger obligatory agreement when they appear inside a CoP. This could also not be explained by an analysis where CoP has the same features as the conjunct in its specifier.

Coordination structure agreement is somewhat sensitive to person and animacy or humanness. We can also assume that a CoP has the number feature [plural]. But either the noun class feature does not percolate in structures with conjuncts of two different noun classes, or the fact that two features are present makes the noun class feature unreadable to Agree. While there are reasons for rejecting the analysis of Swahili argued for in Johannessen (1998), it is not clear how to account for the second conjunct agreement.

Now, reconsider the data introduced above to show that agreement patterns are not affected by person or animacy hierarchies. In (40a), agreement is with second person plural, whereas in (40b), with the inverse order of conjuncts, agreement is with third person plural. However, person features are different from number features, because apparently, person features can percolate from the first conjunct into the CoP but not from the second conjunct.

- (40) a. Juma a- za- mi- ona iwe na uja.  
 1Juma SM1- PERF.DJ- OM2P- see you.SG and 1DEM  
 ‘Juma saw you and him.’  
 b. Juma a- za- wa- ona uja na iwe.  
 1Juma SM1- PERF.DJ- OM2- see 1DEM and you.SG  
 ‘Juma saw him and you.’ [Sambaa]

Similarly, in Haya, first person plural agreement is possible where the first conjunct is first person singular. This is illustrated in (41). Again, this shows that person features are different from number features.

- (41) Inye na omukazi a- ka- tu- bona.  
 me and 1woman SM1- PAST3- OM1P- see  
 ‘The woman and me, he saw us.’ [Haya]

The analysis proposed in van Koppen (2005) for Dutch also does not allow for optionality in agreement with a CoP.<sup>5</sup> Although the two Goals are equally local in syntax, only one of them can be selected as the possible candidate for Agree for any particular configuration in Dutch. Van Koppen argues that this pattern is determined by the morphology. In each construction, agreement will be with the most specific Goal. This corresponds to the most specific agreement morphology in the lexicon. In Dutch there are what van Koppen refers to as “elsewhere” affixes, these are morphemes that have no  $\phi$ -features, while specific affixes have  $\phi$ -features (person and number). However, in Bantu, there are no “elsewhere” affixes, with the possible exception of the default classes, but even those have number and person and only lack gender. It seems either affix is equally specific. This might be the reason while there is optionality.

<sup>5</sup>She notes that there are languages where full agreement and FCA are possible with VS order, including Moroccan Arabic, but does not discuss them further.

For Bantu, we might assume that a CoP, consisting of conjuncts with two different noun classes, has no gender feature (noun class). This is illustrated in (43) with a coordinated subject, shown in (42), in its base position. (43) represents a coordination phrase such as (42), where both conjuncts are singular, animate, third person entities but have two different noun classes. The CoP has no noun class feature, unlike the first conjunct.

(42) *shimba na kui*  
 9lion and 5dog  
 ‘lion and dog’ [Sambaa]

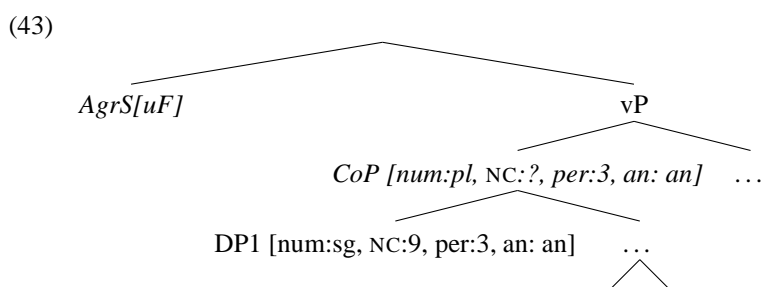

However, this should not affect which agreement pattern is more specific.

Apparently in Bantu, agreement selection is sensitive to the word order of the verb and the complement to be agreed with. There is also some evidence of this in Dutch. Why would agreement be sensitive to the position of the CoP with regard to the verb? Van Koppen (2005) argues that copies left behind by movement only have one set of visible features, namely those of the CoP (Coordination Phrase). The internal structure of the moved elements is invisible to the Probe. This requires an analysis where Agree happens after the movement of the CoP.

It is not clear whether this can account for the Bantu data. For Bantu, it is generally argued that subject agreement requires movement to spec,TP or an equivalent preverbal position (Kinyalolo 1991; Letsholo 2002). However, if agreeing postverbal subjects are treated as elements that are merged in a right-dislocated position, the two assumptions can be maintained. For the preverbal objects, on the other hand, a movement analysis would be needed. Answering this question will be left for future research.

## 7.8 Conclusions

In Sambaa, Haya and Swahili subject and object agreement are affected in the same way by the position of a coordinated noun phrase with regard to the verb: preverbal coordinated noun phrases pattern together and postverbal noun phrases pattern together. Preverbal coordinated noun phrases require full agreement while postverbal noun phrases allow partial agreement. Both subjects and objects allow only FCA and

full agreement in Sambiaa and Haya. However, for some speakers of Swahili, Swahili allows an additional pattern for a small subset of preverbal noun phrases.

The syntactic differences between subjects and objects which gave rise to the debate about the function of the object marker are absent with coordinated noun phrases, agreement patterns are determined by word order not by argument type. Moreover, in all three languages object marking and subject marking are only able to access the highest projection of the CoP or one of the conjuncts. “Anaphoric” pronouns (in the sense of Bresnan and Mchombo (1987), these are pronouns which are linked to their referent not syntactically but through something like co-indexing) would not be expected to be sensitive to the position of an element inside a phrase, since no c-command is needed. While pronominal incorporation is ruled out by the Coordinate Structure Constraint.

Bantu languages differ from Dutch in allowing multiple agreement patterns with postverbal coordinate structures. However, like Dutch they might be sensitive to whether the coordination phrase has moved from its base position. Van Koppen (2005) analysis might be extendable to the Bantu data. However, more research is needed to establish whether preverbal objects have undergone movement, while postverbal subjects have not.

It was shown that Johannessen’s analysis of Swahili is not the right analysis for Swahili or any of the languages under discussion. However, what the correct analysis for SCA could be is left for future research.

Throughout this thesis, we have seen that Agree is sensitive to the features of a noun phrase only if it appears a particular type of hierarchical position. Being located inside of a coordination phrase apparently interferes in the relationship between the DP and the verb, although Agree can still see the features of the first conjunct. It seems that the active features of the first conjunct cannot trigger obligatory Agree from inside of the CoP.

## CHAPTER 8

---

### Conclusions and issues for further research

---

Throughout this thesis, object marking in Smbaa and a number of other Bantu languages was examined from a Minimalist syntax perspective. It was argued that, in Smbaa, Swahili and Haya, object marking takes place by way of Agree. The idea that Bantu languages can be split into two types of languages for object marking as either agreement languages or pronominal languages was rejected. Arguments for and against this view were discussed across a range of syntactic environments, concluding that Agree can account for all three patterns with certain modifications of its subparts: demoting Equidistance and the Defective Intervention Constraint to parameter status and removing the stipulation that the Goal must have active features in order to enter an Agree relation. *Wh*-contexts are the most challenging part for this, because of the complex set of restrictions on object marking.

The first part of this final chapter summarizes the main conclusions of this thesis, while the second part sketches some areas related to the topic of this thesis which are potential topics for further research.

### 8.1 Conclusions

As I have demonstrated here, Bantu languages cannot be split into two clear groups – as object agreement languages and pronominal object marking languages – based on their object marking patterns. In the literature, many properties are suggested as potential tests. However, when examined more closely or checked against more languages, these properties cannot be grouped together systematically in the languages examined here. It is possible that amongst the vast number of Bantu languages, which as shown here display a lot of variation in their syntax, there are languages for to which the agreement analysis proposed here cannot be extended. Nevertheless, it has been

shown that a simple dichotomy between agreement languages and pronoun languages cannot be maintained across the whole language family.

In the case of *wh*-questions, the data is much more complex than whether or not a language allows object marking. While there are languages like Haya which do not allow object marking in any kind of *wh*-environment or in relative clauses, most Bantu languages have a more mixed pattern. One example of this is Chichewa, which does not allow object marking in questions, while requiring it in certain types of relative clauses. Languages such as Swahili and Smbaa show that animacy and definiteness hierarchies can work differently in different types of syntactic environments. While languages which do not allow object marking in *wh*-contexts, do not meet other tests for pronominal object marking.

Bantu-specific criteria for object-hood as well as for the properties of object markers in particular languages were examined. A number of areas of the morphosyntax of Bantu were discussed, including the conjoint/disjoint alternations, (a)symmetry, multiple object constructions, hierarchies, word order facts, and right-dislocation. A set of properties to characterise a local object in Bantu were defined, based on data from Smbaa. Similarly, the properties of right-dislocated elements were analysed for Bantu. It was shown that, although Haya does not meet many of the criteria for local objects, there is no evidence that object-marked objects in Haya are necessarily right-dislocated.

In spite of the variation found, there are some aspects of the morphosyntax which are highly systematic across the Bantu language family. These include the order of the object markers and – at least for Smbaa, Swahili and Haya – the c-command relations in double object constructions. PCC effects can also be shown to be systematic across Bantu, irrespective of the number of object markers a language allows, and irrespective of whether it allows object marking. Bantu languages obey the weak PCC, rather than the strong PCC. The data from Bantu extend the applicability of the PCC beyond weak direct objects to any kind of direct objects.

With regard to agreement with coordinate structures, Haya and Smbaa have been shown to be extremely similar, allowing only full agreement with preverbal elements while allowing both full and partial agreement with postverbal elements. Agreement patterns with coordinate structures were shown to be affected by the order of the verb with regard to the CoP. Preverbal CoPs allow only full agreement, with the exception of the marginal SCA pattern in Swahili, while postverbal CoPs also allow partial agreement.

An analysis was argued for, where each morphologically separate element in the Smbaa verb is treated as a syntactic head, following Julien (2002). Using such a structure, the Bantu languages Smbaa, Swahili and Haya were argued to have object agreement. Agree, in the view taken here, is a relationship between a Probe and a Goal established under c-command, as in (1). The Probe searches its domain and agrees with the first matching Goal. For Agree to take place, only the Probe must have an active feature.

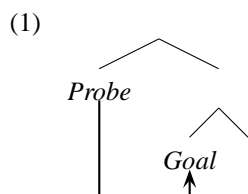

This allows for optional Agree. The cases where agreement is obligatory can be accounted for by making a distinction between different types of features.

For Smbaa, this syntactic operation is argued to be extremely simple. A Probe is active when present in the structure and will always enter an Agree relation with the closest c-commanded matching element. Where a verb shows multiple object markers it was argued that these are hosted by multiple Agree projections. It was argued that there are no phonologically zero object markers because of the locality violation exhibited. The object Agree projections were argued to be absent when no object marking morphology is spelled-out. This enabled us to account for optional object marking. It was argued that a Probe always has an active feature, while only a small subclass of Goals (that is, particular semantic classes of nouns) have an active feature. These cause certain objects to require object marking. It was suggested that the relevant feature is a referential feature.

Haya exhibits Equidistance effects while Smbaa and Swahili do not. This was particularly problematic because double objects in all three languages can be shown to have the same c-command relations. Equidistance effects (Chomsky 2000) are problematic for the unified analysis of Smbaa and Haya as object agreement languages. However, it was shown that the head movement analysis cannot account for the data that is grammatical in Smbaa, Haya and any other Bantu languages with multiple object marking, where the object markers are strictly ordered and their order mirrors the order of the lexical complements. A clitic insertion analysis was shown to have the same problem as the agreement analysis. The solution argued for was to make Equidistance a parameterised rule. This allows for Haya to exhibit Equidistance effects, while accounting for their absence in Bantu languages like Smbaa and Swahili.

It was similarly argued that once an element in Smbaa is agreed with, it does not block agreeing with the next lower element. However, in Swahili this appeared to be the case as only the highest object can ever agree. Using the Defective Intervention Constraint to explain this allowed us to account for all types of agreeing objects in Swahili in the same way.

One particularly important generalization that can be made about Agree based on the Bantu data is that it is possible to agree in person with more than one object, although it was shown that these kinds of constructions are subject to special restrictions, namely to weak the PCC.

The way object marking works in coordination structures in Bantu supports an analysis in terms of agreement for several reasons. Firstly, subject marking and object marking were shown to behave in the same way. Secondly, movement out of one conjunct of a coordinate structure would be impossible, this creates problems for an

incorporation analysis or other types of movement analyses. Lastly, the strong effects of order and location on the possible patterns support a close c-command relationship between the object and the host of the object marker.

## 8.2 Areas for further research

The discussion throughout this thesis dealt with the syntax and morphology of Bantu object markers rather than their meanings (beyond particular features) and pragmatic function. However, for a complete understanding of object marking these should be dealt with as well. Two particular issues are raised here. The first one is the surprising fact that Smbaa object markers can double each other. The second is the issues of why the direct object is sometimes dropped in certain types of double object constructions without being object-marked.

**Two for one** In Smbaa, an object marker can sometimes be doubled. Examples of this are shown in (2). The doubled object marker appears in two different places, immediately next to the verb stem and as the most distant object marker. This construction was marginal and when I tried eliciting it from speakers other than the one who had produced it in the first instance I was generally told it was ungrammatical. However, if the informant explained the context other speakers would also accept these constructions. The likely context I was given was an argument about the object which is doubly marked. In this scenario, the speaker and the hearer are arguing about what has happened to the object which the object-marker that is doubled refers to. Similarly to doubled demonstratives in Smbaa and Swahili, it seems to exhaustively identify the object.

- (2) a. N- za- **ji-** ku- **ji-** etea.  
SM1S- PERF.DJ- OM5- OM2S- OM5- bring.APPL  
'I did bring it to you.'
- b. Viya viazi n- aa- **vi-** ku- **vi-** taghia.  
8DEM 8potato SM1S- REM.DJ- OM8- OM2S- OM8- sell.for.APPL  
'These potatoes, I did sell them for you' [Smbaa]

**One for two** In Smbaa, if there is object marking for the highest object it is possible to drop both objects. For example, when an applicative verb with a benefactive applied object is used in a question to question the benefactive, it is most common to drop the direct object in both question and answer. This is shown in (3). Here the direct object is dropped in both question and answer. Based on the context, the object is known to be a school which is present in the discourse but is not mentioned in either question or answer.

- (3) a. Û- m- zéng- é- à ndáyí?  
SM2S- OM1- build- APPL- PRES.CJ who  
'Who are you building for?'

- b. Tì- wá- zéng- é- à wáná.  
 SM1P- OM2- build- APPL- PRES.CJ 2children  
 ‘We are building for the children.’ [Sambaa]

Apparently one object marker can satisfy the transitivity requirements of the ditransitive verb. However, two object markers are also used in such contexts in natural speech. The example in (4) is from a conversation between a mother and her child that happened to take place in front of the researcher. Two object markers appear in both question and answer.

- (4) a. Q: U- te- chi- m- nka na mwe diisha?  
 SM2S- NPST.DJ- OM7- OM1- give and 18LOC 5window  
 ‘Have you given it to her through the window?’  
 b. A: N- za- chi- m- nka.  
 SM1S- PERF.DJ- OM7- OM1- give  
 ‘I gave it (to) her.’ [Sambaa]

Some Bantuists suggest that constructions such as (3b) indicate that Bantu verbs are not transitive in the same way as verbs in languages like English. However, in Spanish double object constructions, in question-answer pairs, a definite direct object can be expressed by a clitic, as in (5a). An indefinite direct object is dropped, as in (5b).<sup>1</sup>

- (5) a. ¿Le diste el libro? Sí, se lo di.  
 to.him gave.2S the book yes to.him it gave.1S  
 ‘Did you give him the book? Yes, I did’ (lit. gave it him)  
 b. ¿Le diste un libro? Sí, le di.  
 to.him gave.2S a book yes to.him gave.1S  
 ‘Did you give him a book? Yes, I did’ (lit. gave him) [Spanish]

The fact that the two patterns found in Bantu are also found in unrelated languages might indicate that the distinction is not related to argument structure in Bantu but to more general properties of human language. In Spanish, there is a morphosyntactic reason for the difference between (5). Spanish clitics are sensitive to animacy and definiteness, similar to the way object markers work in some of the Bantu languages discussed in chapter 3.

In Sambaa, the difference might be due to the discourse properties of the direct object. At this point it is not clear whether there is any difference between the two options in terms of contexts or potentially also subtle meaning differences and what the actual frequencies are. A large corpus of natural conversational speech might eventually provide answers to these questions.

**Why is multiple object marking so rare?** One of the most puzzling questions about Sambaa object marking is why multiple object markers are almost never used in natural speech. Many Sambaa speakers contributed to the data in this thesis beyond the

<sup>1</sup>Thanks to Gerardo Fernández-Salgueiro for the data.

main informants. A fairly extensive database of natural speech was built based on transcribed recordings of traditional stories and other narratives. Some older written narratives are also available, such as the stories in Roehl (1911) and The Bible Society in Tanzania (1969); Tulleman (2006). Yet, while not a single speaker found constructions with two object markers problematic, examples of several object markers are practically non-existent in natural speech. Only four natural examples of two object markers appear in my corpus, while verbs with three object markers are not found at all. Apart from the ditransitive verb in (4), applicative verbs are found with two object markers.

---

## References

---

- Adger, David, and Daniel Harbour. 2007. The syntax and syncretisms of the Person Case Constraint. *Syntax* 10:2–37.
- Adger, David, and George Tsoulas. 2004. Circumstantial adverbs and aspect. In *The syntax of adverbials*, ed. S. Engelberg, J. R. Austin, and G. Rauh. John Benjamins.
- Aissen, Judith. 2003. Differential object marking: Iconicity vs. economy. *Natural Language and Linguistic Theory* 21:435–483.
- Amidu, Assibi A. 2006. *Pronouns and pronominalizations in Kiswahili grammar*. Cologne: Rüdiger Köppe.
- Anagnostopoulou, Elena. 2003. *The syntax of ditransitives: Evidence from clitics*. Berlin: Mouton de Gruyter.
- Ashton, Ethel O. 1944. *Swahili grammar*. London: Longmans.
- Averintseva-Klisch, Maria. 2008. German right dislocation and afterthought in discourse. In *Constraints in Discourse*, ed. Anton Benz and Peter Kühnlein, 225–247. Amsterdam: John Benjamins.
- Baker, Mark C. 1988a. *Incorporation: A theory of grammatical function changing*. Chicago: University of Chicago Press.
- Baker, Mark C. 1988b. Theta Theory and the syntax of applicatives in Chichewa. *Natural Language and Linguistic Theory* 6:353–389.
- Baker, Mark C. 1996. *The Polysynthesis Parameter*. Oxford: Oxford University Press.
- Baker, Mark C. 2003. Agreement, dislocation, and partial configurationality. In *Formal approaches to function in grammar*, ed. Andrew Carnie, Heidi Harley, and MaryAnn Willie, 107–132. Amsterdam: John Benjamins.

- Baker, Mark C. 2008. *The syntax of agreement and concord*. Cambridge: Cambridge University Press.
- Baker, Mark C., and Chris Collins. 2006. Linkers and the internal structure of vP. *Natural Language and Linguistic Theory* 24:307–354.
- Barrett-Keach, Camilla. 1985. *The syntax and interpretation of the relative clause construction in Swahili*. New York: Garland.
- Barrett-Keach, Camilla. 1986. Word-internal evidence from Swahili for Aux/Infl. *Linguistic Inquiry* 17:559–564.
- Bearth, Thomas. 2003. Syntax. In *The Bantu Languages*, ed. Derek Nurse and Gérard Philippson, 127–142. London: Routledge.
- Beaudoin-Lietz, Christa, Derek Nurse, and Sarah Rose. 2004. Pronominal object marking in Bantu. In *Proceedings of the 4th World Congress of African Linguistics*, ed. A. Akinlabi and O. Adesola, 198–197. Cologne: Rüdiger Köppe.
- Beck, S., and H. Rullmann. 1999. A flexible approach to exhaustivity in questions. *Natural Language Semantics* 7:249–298.
- Béjar, Susana, and Milan Rezac. 2009. Cyclic Agree. *Linguistic Inquiry* 40:35–73.
- Bentley, Mayrene E. 1994. The syntactic effects of animacy in Bantu languages. Doctoral Dissertation, Indiana University.
- Besha, Ruth M. 1985. The study of tense and aspect in Shambala. Doctoral Dissertation, University of Dar es Salaam.
- Besha, Ruth M. 1989a. Mood in Bantu languages: An exemplification from Shambala. In *Studies in Tanzanian languages 5*. Tokyo: Institute for the Study of Languages and Cultures of Asia and Africa.
- Besha, Ruth M. 1989b. *A study of tense and aspect in Shambala*. Berlin: Dietrich Reimer.
- Besha, Ruth M. 1993. *A classified vocabulary of the Shambala language, with outline grammar*. Tokyo: Institute for the Study of Languages and Cultures of Asia and Africa.
- Besha, Ruth M. 2000. Miundo ya urejeshi katika Kishambala. In *Lugha za Tanzania - languages of Tanzania: studies dedicated to the memory of Prof. Clement Maganga*, ed. Kulikoyela Kahigi, Yared Kihore, and Maarten Mous. Leiden: CNWS Publications.
- Bhatt, Rajesh, and Elena Anagnostopoulou. 1996. Object shift and specificity: Evidence from *ko*-phrases in Hindi. In *CLS 32: Papers from the Main Session*, volume 1, 11–22. Chicago: University of Chicago Press.

- Bleek, W. H. I. 1862. *A comparative grammar of South African languages: Part 1*. Cape Town: J. C. Juta and Trüber.
- Bleek, W. H. I. 1869. *A comparative grammar of South African languages: Part 2*. Cape Town: J. C. Juta and Trüber.
- Bokamba, Eyamba. 1985. Verbal agreement as a noncyclic rule in Bantu. In *African linguistics*, ed. Didier Goyvaerts, 9–54. Amsterdam: John Benjamins.
- Bonet, Eulàlia. 1991. Morphology after syntax: Pronominal clitics in Romance. Doctoral Dissertation, MIT.
- Bonet, Eulàlia. 1994. The Person-Case Constraint: A morphological approach. *MIT Working Papers in Linguistics* 22:33–52.
- Borsley, Robert D. 2005. Against ConjP. *Lingua* 115:461–482.
- Bosson, Georg. 1985. *Differentielle Objektmarkierung in den neuiranischen Sprachen*. Tübingen: Gunter Narr Verlag.
- Bresnan, Joan. 2001. *Lexical-functional syntax*. Oxford: Blackwell.
- Bresnan, Joan, and Sam Mchombo. 1987. Topic, pronoun, and agreement in Chichêwa. *Language* 63:741–782.
- Bresnan, Joan, and Lioba Moshi. 1990. Object asymmetries in comparative Bantu syntax. *Linguistic Inquiry* 21:147–185.
- Bright, William. 1992. *International encyclopedia of linguistics*. Oxford: Oxford University Press.
- Buell, Leston C. 2005. Issues in Zulu verbal morphosyntax. Doctoral Dissertation, UCLA.
- Buell, Leston C. 2006. The Zulu conjoint/disjoint verb alternation: focus or constituency? *ZAS Papers in Linguistics* 43:9–30.
- Buell, Leston C. 2008. VP-internal DPs and right dislocation in Zulu. *Linguistics in the Netherlands* 37–49.
- Buell, Leston C. 2009a. Class 17 as a non-locative noun class in Zulu. paper presented at *Bantu 3*, Tervuren, 24–28 March 2009.
- Buell, Leston C. 2009b. Evaluating the immediate postverbal position as a focus position in Zulu. In *Selected Proceedings of the 38th Annual Conference on African Linguistics*, 166–172. Somerville, MA: Cascadilla Press.
- Buell, Leston C., and Kristina Riedel. 2008. The conjoint/disjoint alternation in Sambaa and Zulu. Paper presented at the TINdag 2008.

- Bukuru, Denis. 1998. Object marking in Kirundi and Kiswahili. Master's thesis, University of Dar es Salaam.
- Byarushengo, Ernest R., Larry M. Hyman, and Sarah Tenenbaum. 1976. Tone, accent and assertion in Haya. In *Studies in Bantu tonology*, ed. Larry M. Hyman, 183–205. Los Angeles: Department of Linguistics, University of Southern California.
- Carstens, Vicki M. 2002. Multiple Agreement and case deletion: Against  $\phi$ -incompleteness. *Syntax* 4:147–163.
- Carstens, Vicki M. 2005. Agree and EPP in Bantu. *Natural Language and Linguistic Theory* 23:219–279.
- Cecchetto, Carlo. 1999. A comparative analysis of left and right dislocation in Romance. *Studia Linguistica* 53:40–67.
- Cheng, Lisa, and Laura J. Downing. 2009. Where's the topic in Zulu? *The Linguistic Review* 26:207–238.
- Chomsky, Noam. 1995. *The Minimalist Program*. Cambridge, MA: MIT Press.
- Chomsky, Noam. 2000. Minimalist inquiries: The framework. In *Step by step*, ed. R. Martin, D. Michaels, and J. Uriagereka, 89–155. Cambridge, MA: MIT Press.
- Chomsky, Noam. 2001. Derivation by phase. In *Ken Hale: A life in language*, ed. M. Kenstowicz, 1–52. Cambridge, MA: MIT Press.
- Chomsky, Noam. 2007. Approaching UG from below. In *Interfaces + recursion = language?*, ed. Uli Sauerland and Hans-Martin Gärtner, 1–29. Berlin: Mouton de Gruyter.
- Chomsky, Noam. 2008. On phases. In *Foundational issues in linguistic theory*, ed. Robert Freidin, Carlos P. Otero, and Maria Luisa Zubizarreta, 133–166. Cambridge, MA: MIT Press.
- Cinque, Guglielmo. 1999. *Adverbs and functional heads: A cross-linguistic perspective*. Oxford: Oxford University Press.
- Cole, Desmond T. 1955. *An introduction to Tswana grammar*. London: Longmans.
- Collins, Chris. 2004. The agreement parameter. In *Triggers*, ed. Anne Breitbarth and Henk van Riemsdijk. Berlin: Mouton de Gruyter.
- Corbett, Greville G. 2006. *Agreement*. Cambridge: Cambridge University Press.
- Creissels, Denis. 1996. Conjunctive and disjunctive verb forms in Setswana. *South African Journal of African Linguistics* 16:109–115.
- Croft, William. 2003. *Typology and universals*. Cambridge: Cambridge University Press.

- Dammann, Ernst. 1954. Reziprok und Assoziativ in Bantusprachen. *Zeitschrift der deutschen morgenländischen Gesellschaft* 29:163–174.
- de Hoop, Helen, and Monique Lamers. 2006. Incremental distinguishability of subject and object. In *Case, Valency and Transitivity*, ed. Leonid Kulikov, Andrej Malchukov, and Peter de Swart. Amsterdam: John Benjamins.
- de Swart, Peter. 2007. Cross-linguistic variation in object marking. Doctoral Dissertation, Radboud University Nijmegen.
- Demuth, Katherine, and Carolyn Harford. 1999. Verb raising and subject inversion in comparative Bantu. *Journal of African Languages and Linguistics* 20:41–61.
- Demuth, Katherine, and M. Johnson. 1990. Interactions between discourse function and agreement in Setawana. *Journal of African Languages and Linguistics* 11:21–35.
- Diesing, Molly. 1992. *Indefinites*. MIT Press.
- Doke, Clement M. 1931. *Textbook of Zulu grammar*. London: Longmans.
- Doke, Clement M., and Sophonia M. Mofokeng. 1974. *Textbook of Southern Sotho grammar*. London: Longmans.
- Duranti, Alessandro. 1977. Relative clauses. In *Haya grammatical structure*, ed. Ernest R. Byarushengo, Alessandro Duranti, and Larry M. Hyman, 119–132. Los Angeles: Department of Linguistics, University of Southern California.
- Duranti, Alessandro. 1979. Object clitic pronouns in Bantu and the Topicality Hierarchy. *Studies in African Linguistics* 10:31–45.
- Duranti, Alessandro, and Ernest R. Byarushengo. 1977. On the notion of “direct object”. In *Haya grammatical structure*, ed. Ernest R. Byarushengo, Alessandro Duranti, and Larry M. Hyman, 45–71. Los Angeles: Department of Linguistics, University of Southern California.
- É. Kiss, Katalin. 1993. Wh-movement and specificity. *Natural Language and Linguistic Theory* 11:85–120.
- Feierman, Steven. 1974. *The Shambaa kingdom*. Madison: University of Wisconsin Press.
- Feierman, Steven. 1990. *Peasant intellectuals: Anthropology and history in Tanzania*. Madison: University of Wisconsin Press.
- Gensler, Orin D. 2003. Object ordering in verbs marking two pronominal objects: Non-explanation and explanation. *Linguistic Typology* 7:187–231.
- Givón, Talmy. 1970. The resolution of gender conflicts in Bantu conjunction: When syntax and semantics clash. In *CLS 6: The Main Session*.

- Gordon, Raymond G. Jr. 2005. *Ethnologue: Languages of the world*. Dallas: SIL International.
- Guthrie, Malcolm. 1971. *Comparative Bantu: an introduction to the comparative linguistics and prehistory of the bantu languages*. Farnborough: Gregg International.
- Harjula, Lotta. 2004. *The Ha language of Tanzania*. Cologne: Rüdiger Köppe.
- Harley, Heidi. 1995. Subjects, events and licensing. Doctoral Dissertation, MIT.
- Haspelmath, Martin. 2004. Explaining the ditransitive person-role constraint: A usage-based account. *Constructions* 2.
- Henderson, Brent. 2006a. Multiple agreement and inversion in Bantu. *Syntax* 9:275–289.
- Henderson, Brent. 2006b. The syntax and typology of Bantu relative clauses. Doctoral Dissertation, University of Illinois at Urbana-Champaign.
- Hiraiwa, Ken. 2001. Multiple Agree and the Defective Intervention Constraint in Japanese. *MIT Working Papers in Linguistics* 40:67–80.
- Hualde, José I. 1989. Double object constructions in Kirimi. In *Current approaches to African linguistics 5*, ed. Paul Newman and Robert D. Botne, 179–189. Dordrecht: Foris Publications.
- Hyman, Larry M. 1999. The interaction between focus and tone in Bantu. In *The Grammar of Focus*, ed. Georges Rebuschi and Laurice Tuller, 151–177. Amsterdam: John Benjamins.
- Hyman, Larry M. 2003. Suffix ordering in Bantu: a morphocentric approach. *Yearbook of Morphology 2002* 245–281.
- Hyman, Larry M., and Alessandro Duranti. 1982. On the object relation in Bantu. In *Studies in transitivity*, ed. S. A. Thompson and P. Hopper, 217–239. New York: Academic Press.
- Hyman, Larry M., and Anne Hawkinson. 1974. Hierarchies of natural topics in Shona. *Studies in African Linguistics* 5.
- Hyman, Larry M., and Maria Polinsky. 2006. Focus in Aghem. Forthcoming in *Studies in Information Structure*.
- Hyman, Larry M., and John Watters. 1984. Auxiliary focus. *Studies in African Linguistics* 15:233–273.
- Jayaseelan, K.A. 2002. Question movement and how some SVO languages handle it. In *Proceedings of Glow in Asia, Taipei 2002*.
- Jayaseelan, K.A. 2003. Questions words in focus positions. *Linguistic Variation Yearbook* 3:69–99.

- Johannessen, Janne B. 1998. *Coordination*. Cambridge: Cambridge University Press.
- Johnstone, Patrick, and Jason Mandryk. 2001. *Ethnologue: Languages of the world*. Dallas: SIL International.
- Julien, Marit. 2002. *Syntactic heads and word formation*. Oxford: Oxford University Press.
- Kageyama, Taro. 1977. Conjunction. In *Haya grammatical structure*, ed. Ernest R. Byarushengo, Alessandro Duranti, and Larry M. Hyman, 133–141. Los Angeles: Department of Linguistics, University of Southern California.
- Kähler-Meyer, E. 1962. Studien zur Tonalen Struktur der Bantusprachen: Shambala. *Afrika und Übersee* 46:1–43.
- Katamba, Francis. 2003. Bantu nominal morphology. In *The Bantu languages*, ed. Derek Nurse and Gerard Philippson, 103–120. London: Routledge.
- Kayne, Richard K. 1994. *The antisymmetry of syntax*. Cambridge, MA: MIT Press.
- Kimenyi, Alexandre. 1978. *A relational grammar of Kinyarwanda*. Berkeley, CA: University of California Press.
- Kinyalolo, Kasangati K. W. 1991. Syntactic dependencies and the SPEC-Head Agreement Hypothesis in Kilega. Doctoral Dissertation, UCLA.
- Krifka, Manfred. 1995. Swahili. In *Syntax*, ed. Joachim Jacobs, Arnim von Stechow, Wolfgang Sternefeld, and Theo Vennemann, 1397–1418. Berlin: Mouton de Gruyter.
- LangHeinrich, F. 1921. *Schambalawörterbuch*. Hamburg: Friederichsen.
- Larson, Richard K. 1988. On the double object construction. *Linguistic Inquiry* 19:335–391.
- Larson, Richard K. 1990. Double objects revisited: Reply to Jackendoff. *Linguistic Inquiry* 21:589–632.
- Letsholo, Rose M. 2002. Syntactic domains in Ikalanga. Doctoral Dissertation, University of Michigan.
- Maho, Jouni. 2008. The new updated Guthrie list (NUGL): the web version. <http://goto.glocalnet.net/mahopapers/nuglonline.pdf>.
- Malchukov, Andrej. 2008. Animacy and asymmetries in differential case marking. *Lingua* 118:203–221.
- Marantz, Alec. 1993. Implications of asymmetries in double object constructions. In *Theoretical aspects of Bantu grammar*, ed. Sam Mchombo, 113–150. Stanford, CA: CSLI Publications.

- Marten, Lutz. 2000. Agreement with conjoined noun phrases in Swahili. *Afrikanistische Arbeitspapiere* 64:75–96.
- Marten, Lutz. 2005. The dynamics of agreement and conjunction. *Lingua* 115:527–547.
- Marten, Lutz, and Nancy C. Kula. 2008. Object marking and morpho-syntactic variation in Bantu. in preparation.
- Marten, Lutz, Nancy C. Kula, and Nhlanhla Thwala. 2007. Parameters of morpho-syntactic variation in Bantu. *Transactions of the Philological Society* 105:253–338.
- Marten, Lutz, and Deograsia Ramadhani. 2001. An overview of object marking in Kiluguru. *SOAS Working Papers in Linguistics* 11:259–275.
- Mayer, Mercer. 1969. *Frog, where are you?*. New York: Dial Books for Young Readers.
- McGinnis, Martha. 2004. Lethal ambiguity. *Linguistic Inquiry* 35:47–95.
- Mchombo, Sam. 2004. *The syntax of Chichewa*. Cambridge: Cambridge University Press.
- Mchombo, Sam A. 2001. Effects of head-marking on constituent order in Chichewa. In *Proceedings of the LFG 01 Conference*, ed. Miriam Butt and Tracy Holloway King, 221–237. Stanford, CA: CSLI Publications.
- Meeussen, A. E. 1955. Tonunterschiede als Reflexe von Quantitätsunterschieden im Shambala. In *Afrikanistische studien*, ed. J. Lukas. Berlin: Akademie Verlag.
- Meeussen, A. E. 1959. *Essai de grammaire rundi*. Tervuren: Musée royal de l’Afrique centrale.
- Meeussen, A. E. 1967. Bantu grammatical reconstruction. *Annales du Musée Royal de l’Afrique Centrale Tervuren* 8:80–121.
- Meinhof, Carl. 1899. *Grundriss einer Lautlehre der Bantusprachen*. Leipzig: F. A. Brockhaus.
- Meinhof, Carl. 1906. *Grundzüge einer vergleichenden Grammatik der Bantusprachen*. Berlin: Reimer.
- Morimoto, Yukiko. 2002. Prominence mismatches and differential object marking in Bantu. In *Proceedings of the LFG02 Conference*, ed. Miriam Butt and Tracy Holloway King, 296–314. Stanford, CA: CSLI Publications.
- Morolong, Malillo, and Larry M. Hyman. 1977. Animacy, objects and clitics in Sesotho. *Studies in African Linguistics* 8:199–218.

- Mous, Maarten. 1997. The position of the object in Tunen. In *Object Positions in Benue-Kwa*, ed. Rose-Marie Déchaine and Victor Manfredi, 123–37. The Hague: Holland Institute of Generative Linguistics.
- Mous, Maarten. 2003a. *The making of a mixed language: The case of Maá/Mbugu*. Amsterdam: John Benjamins.
- Mous, Maarten. 2003b. Nen (A44). In *The Bantu Languages*, ed. Derek Nurse and Gérard Philippon, 283–306. London: Routledge.
- Muriungi, Peter K. 2008. Phrasal movement inside Bantu verbs. Doctoral Dissertation, University of Tromsø.
- Mwalonya, J., A. Nicolle, J. Nicolle, and J. Zimbu. 2004. *Mgombato: Digo-English-Swahili dictionary*. Nairobi: BTL.
- Myers, Scott P. 1987. Tone and the structure of words in Shona (Bantu, Zimbabwe). Doctoral Dissertation, Umass Amherst.
- Myers, Scott P. 1990. *Tone and the structure of words in Shona*. New York: Garland Press.
- Nash, Jay A. 1992. Aspects of Ruwund grammar. Doctoral Dissertation, University of Illinois at Urbana-Champaign.
- Ndayiragije, Juvénal. 1999. Checking economy. *Linguistic Inquiry* 30:399–444.
- Nevins, Andrew. 2007. The representation of third person and its consequences for person-case effects. *Natural Language and Linguistic Theory* 25:273–313.
- Ngonyani, Deogratias S. 1996. The morphosyntax of applicatives. Doctoral Dissertation, UCLA.
- Ngonyani, Deogratias S. 2001. Evidence for head raising in Kiswahili relative clauses. *Studies in African Linguistics* 30:59–74.
- Nichols, Johanna. 1986. Head-marking and dependent-marking grammar. *Language* 62:56–119.
- Nilsen, Oystein. 1998. The syntax of circumstantial adverbs. Ms. University of Tromsø.
- Nurse, Derek. 1979. Description of sample Bantu languages of Tanzania. *African Languages* 5:90–100.
- Nurse, Derek. 2000. *Inheritance, contact, and change in two East African languages*. Cologne: Rüdiger Köppe.
- Nurse, Derek, Thomas Hinnebusch, and Martin Mould. 1981. *Studies in the classification of eastern Bantu languages*. Hamburg: Buske.

- Nurse, Derek, and Gérard Philippson. 1975. The north-eastern Bantu languages of Kenya and Tanzania. *Kiswahili* 42:1–28.
- Nurse, Derek, and Gérard Philippson, ed. 2003. *The Bantu languages*. London: Routledge.
- Nyembezi, C. L. S. 1990. *Learn more Zulu*. Pietermaritzburg: Shutter and Shooter.
- Odden, David. 1982. Tonal phenomena in Kishambaa. *Studies in African Linguistics* 13:177–208.
- Olson, Howard S. 1964. *The phonology and morphology of Rimi*. Hartford, CT: The Hartford Seminary Foundation.
- Ormazabal, Javier, and Juan Romero. 2007. The object agreement constraint. *Natural Language and Linguistic Theory* 25:315–347.
- Philippson, Gérard. 1991. Tons et accent dans les langues bantu d’Afrique Orientale. Doctoral Dissertation, Université René Descartes (Paris V).
- Pylkkänen, Liina. 2002. Introducing arguments. Doctoral Dissertation, MIT.
- Rezac, Milan. 2006. Escaping the Person Case Constraint. *Linguistic Variation Yearbook* 6:97–138.
- Rizzi, Luigi. 1997. The fine structure of the left periphery. In *Elements of grammar*, ed. Liliane Haegeman, 281–337. Dordrecht: Kluwer.
- Roberts, Ian. 2003. Head movement. In *The handbook of contemporary syntactic theory*, ed. Mark Baltin and Chris Collins, 113–147. Oxford: Blackwell.
- Roehl, Karl. 1911. *Versuch einer systematischen Grammatik der Schambalaspache*. Hamburg: Friederichsen.
- Ross, J. R. 1967. Constraints on variables in syntax. Doctoral Dissertation, MIT.
- Rubanza, Yunus I. 1988. Linear order in Haya verbal morphology: Theoretical implications. Doctoral Dissertation, Michigan State University.
- Rugemalira, Josephat M. 1991. What is a symmetrical language? Multiple object constructions in Bantu. In *Proceedings of the 17th Annual Meeting of the Berkeley Linguistics Society: Papers from the special session*, ed. Kathleen Hubbard, 200–209. Berkeley, CA: Berkeley Linguistics Society.
- Rugemalira, Josephat M., and Henry T. Muzale. 2008. Researching and documenting the languages of Tanzania. *Language Documentation and Conservation* 1:68–108.
- Rullmann, H., and S. Beck. 1998. Presupposition projection and the interpretation of *which*-questions. In *SALT: Proceedings from Semantics and Linguistics Theory*, ed. D. Stgrolovitch and A. Lawson, volume 8, 215–232. Ithaca, NY: CLC Publications.

- Sabel, Joachim, and Jochen Zeller. 2006. *Wh*-question formation in Nguni. In *Selected Proceedings of the 35th Annual Conference on African Linguistics*, ed. John Mugane, J. Hutchinson, and D. Worman, 271–283. Somerville, MA: Cascadilla Press.
- Samek-Lodovici, Vieri. 2006. When right dislocation meets the left-periphery: A unified analysis of Italian non-final focus. *Lingua* 116:836–873.
- Schadeberg, Thilo. 1986. Tone cases in Umbundu. *Africana Linguistica* 10:423–447.
- Schadeberg, Thilo. 1992. *A sketch of Swahili morphology*. Cologne: Rüdiger Köppe.
- Schadeberg, Thilo. 1995. Object Diagnostics in Bantu. In *Issues in African languages and linguistics: Essays in honour of Kay Williamson*, ed. E. N. Emenajo and O. Ndimele, 173–180. National Institute for Nigerian Languages.
- Seidel, Amanda, and Alexis Dimitriadis. 1997. The discourse function of object marking in Swahili. In *CLS 33: The Main Session*, 373–389.
- Siewierska, Anna. 2004. *Person*. Cambridge: Cambridge University Press.
- Siewierska, Anna. 2008. Verbal person marking. In *The world atlas of language structures online*, ed. Martin Haspelmath, Matthew S. Dryer, David Gil, and Bernard Comrie. Munich: Max Planck Digital Library. URL (<http://wals.info/feature/102> (..))
- Sio, Joanna. 2006. Modification and reference in the Chinese nominal. Doctoral Dissertation, Universiteit Leiden.
- Steere, E. 1867. *Collections for a handbook of the Shambala language*. Magila, Msalabani: Universities' Mission to Central Africa.
- Stucky, Susan. 1983. Verb phrase constituency and linear order in Makuwa. In *Order, Concord and Constituency*, ed. G. Gazdar, Ewan Klein, and G. K. Pullum, 75–94. Dordrecht: Foris Publications.
- Tak, Jin-Young, and Robert Botne. 1998. Asymmetric coordination in Lega. *Afrikanistische Arbeitspapiere* 54:47–68.
- Tenenbaum, Sarah. 1977. Left- and Right-Dislocations. In *Haya grammatical structure*, ed. Ernest R. Byarushengo, Alessandro Duranti, and Larry M. Hyman. Los Angeles: Department of Linguistics, University of Southern California.
- The Bible Society in Tanzania. 1969. *Kilagha kihya*. Dodoma, Tanzania: The Bible Society in Tanzania.
- Thwala, Nhlanhla. 2006. Parameters of variation and complement licensing in Bantu. In *Papers in Bantu Grammar and Description*, volume 43, 209–232. ZAS Papers in Linguistics.
- Torrego, Esther. 1998. *The dependencies of objects*. Cambridge, MA: MIT Press.

- Travis, Lisa. 1984. Parameters and effects of word order variation. Doctoral Dissertation, MIT.
- Tullemans. 2006. Shimolezi za kishambaa. Ms., edited and translated by Harrie Tullemans (original prepared by Evangelische Missionsgesellschaft für Deutsch-Ost-Afrika published 1911 by C. Bertelsman, Gütersloh).
- Ura, Hiroyuki. 2000. *Checking theory and grammatical functions in universal grammar*. Oxford: Oxford University Press.
- van der Spuy, Andrew. 1993. Dislocated noun phrases in Nguni. *Lingua* 90:335–355.
- van der Wal, Jenneke. 2006. The disjoint verb form and an empty immediate after verb position in Makhuwa. *ZAS Papers in Linguistics* 43:233–256.
- van der Wal, Jenneke. 2009. Word order and information structure in Makhuwa-Enahara. Doctoral Dissertation, Universiteit Leiden.
- van Koppen, Marjo. 2005. One probe - two goals: Aspects of agreement in Dutch dialects. Doctoral Dissertation, Universiteit Leiden.
- van Spaandonck, M. 1967. Morfotonologische analyse in Bantutalen. Doctoral Dissertation, Ghent.
- Wald, Benji. 1979. The development of the Swahili object marker: A study of the interaction of syntax and discourse. In *Discourse and Syntax*, ed. Talmy Givón, 505–524. New York: Academic Press.
- Wald, Benji. 1997. Varbrul and the human/inanimate polarization of the Swahili object marker. In *Towards a social science of language*, ed. G.R. Guy, C. Feagin, D. Schiffrin, and J. Baugh. Amsterdam: John Benjamins.
- Wald, Benji. 1998. Issues in the north/south split of East Bantu. In *Language history and language description in africa*, ed. Ian Maddieson and Tom Hinnebusch, 95–106. Trenton, NJ: Africa World Press.
- Ward, Gregory, and Betty Birner. 1995. Definiteness and the English existential. *Language* 71:722–742.
- Watters, John. 1979. Focus in Aghem. In *Aghem grammatical structure*, ed. L. M. Hyman. Los Angeles: Department of Linguistics, University of Southern California.
- Woolford, Ellen. 1999. Animacy hierarchy effects on object agreement. In *New Dimensions in African Linguistics and Languages*, ed. Paul Kotey, 203–216. Trenton, NJ: Africa World Press.
- Woolford, Ellen. 2000. Agreement in disguise. In *Advances in African linguistics*, ed. Vicki M. Carstens and Frederick Parkinson, 103–117. Trenton, NJ: Africa World Press.

- Woolford, Ellen. 2001. Conditions on object agreement in Ruwund (Bantu). In *The Umass volume on indigenous languages*, ed. E. Benedicto. Amherst, MA: GLSA.
- Yoneda, Nobuko. 2008. Word order and information structure in Matengo. Paper presented at the conference on *Movement and Word order in Bantu 7-8 March 2008*, LUCL, Universiteit Leiden.
- Yukawa, Y. 1984. *A classified dictionary of the Sambia language*. Tokyo: Institute for the Study of Languages and Cultures of Asia and Africa.
- Zerbian, Sabine. 2006. Expression of information structure in the Bantu language Northern Sotho. Doctoral Dissertation, Humboldt University.
- Zwart, Jan-Wouter. 1997. A short note on relative constructions in Swahili and in Lega. Ms. Groningen.



---

## Index

---

- accessibility hierarchy, 82  
Agree, 11, 12, 91, 92, 95–98, 100, 101, 104, 106, 108, 117, 123, 124, 130, 132, 133, 142, 145, 162, 193, 206, 208, 209  
animacy, 47, 48, 62, 74, 78, 83, 157  
    humans, 46, 47, 155  
    inanimates, 156  
    non-humans, 47  
Asu (Pare), 13, 25  
asymmetry, 62, 78–82  
  
Bantu, 1, 3–9, 11–13, 16, 17, 20, 21, 23, 26, 27, 31, 32, 34, 41–47, 52, 53, 55–59, 65, 67, 70, 71, 74–76, 78, 80, 84, 87–89, 92–95, 99–101, 104, 106, 109, 111, 114, 117, 119, 122, 127, 128, 133, 135, 136, 138, 139, 142, 144, 148, 150–156, 162, 163, 166, 173, 180, 185–187, 189, 190, 198, 205–211  
    Northeast Coastal, 13  
Bantu verb structure  
    prefixes, 93  
    suffixes, 93  
Bemba, 5, 75, 185  
Bondei, 14  
  
Chaga, 59, 76, 87, 119, 122  
Chichewa, 4, 41, 42, 54–59, 63, 65, 67, 78, 80–82, 86, 89, 119, 122, 154, 184, 185, 187  
closest c-command, 95, 98, 133  
conjoint, 32–35, 54, 64, 65, 162, 163, 181  
Coordinate Structure Constraint, 191, 196  
  
definiteness, 46, 48, 49, 51, 52, 157, 158, 186  
Dhaiso, 13  
DIC, 91, 96–98, 108, 132  
Digo, 13  
disjoint, 32–35, 54, 64, 65, 162, 163, 181  
ditransitives, 102, 140, 148, 150, 151  
Dzamba, 190  
  
EPP, 100, 101, 116  
equally local, 192, 193, 206  
Equidistance, 92, 96, 97, 107, 129, 130, 133, 193, 211  
  
FCA, 189, 192–202, 205, 207  
full agreement, 190, 194, 199, 200, 208  
  
Ha, 60  
Haya, 8–10, 12, 17, 42, 43, 52, 53, 59, 60, 67, 69–74, 76, 78, 81, 85, 86, 88, 91, 95, 97, 101, 110, 111, 122–125, 127, 129, 130, 133, 136, 141, 142, 144, 149, 152, 154, 180, 181,

- 183–187, 192, 193, 201–203, 206, 207, 210, 211
- Bugabo, 85
- head movement, 93, 125, 127, 128
- Head Movement Constraint, 125, 128
- IAV, 154, 163, 165, 169, 170
- incorporation, 41, 54, 55, 68, 89, 93, 104, 120, 123, 125, 126, 133, 191, 195, 203, 208
- Kinande, 101
- Kinyarwanda, 6, 75, 77, 122
- Konzime, 5
- Kwanyama, 76
- Limbang, 149, 150, 152
- local object, 43, 58, 59, 61, 63, 64, 66, 67, 70, 73, 82, 85, 86, 89
- Luguru, 190
- Lunda, 5
- Makhuwa, 31, 34, 44, 52, 53, 55, 75, 154, 155
- Match, 95
- Matengo, 41
- Mbugu, 25
- Ndebele, 205
- Ngulu, 14
- Nguni, 31
- Northern Sotho, 42
- NPIs, 50
- Nyaturu, 5, 43, 51, 53, 59, 63, 75, 150, 151
- passive, 79, 84
  - Haya, 81, 85
  - Sambaa, 79
  - Swahili, 80, 86
- PCC, 137–141
- person, 91, 100, 101, 115–117, 123, 133, 135–137, 139–145, 148–152
- proper names, 44
- Rangi, 25
- right-dislocation, 55, 65, 67, 68, 70, 72, 73
- Rundi, 4, 31, 78, 163
- Ruwund, 4, 5, 43, 44, 52, 53, 59–63, 70, 74, 75, 83, 155
  - Musumban, 60–62
- Sambaa, 1–3, 6, 8–15, 20, 22–28, 32, 34, 35, 37, 40, 42, 43, 45, 47, 49, 53, 56, 57, 59–61, 63–66, 73–81, 83–89, 91, 92, 94, 95, 97–101, 103, 104, 106, 108–111, 113, 115–121, 123, 127, 130–133, 136, 140, 141, 144, 145, 148, 149, 151–170, 172–176, 180–183, 185, 187, 189, 192–213
  - dialects, 14
- SCA, 189–191, 194, 205, 208
- Sesotho, 4, 59
- Shona, 93, 129
- Sotho-Tswana, 31
- specificity, 48, 50–52, 157, 186
- subject agreement, 44, 99, 100
- subject marker, 56, 70, 76, 93, 100, 128
- Swahili, 3–5, 9, 10, 12–14, 16, 17, 21, 22, 25, 35, 40, 42, 44, 46–50, 53, 55, 57, 59, 62, 63, 70, 75, 78, 80, 81, 86–88, 92, 94, 101, 105, 106, 110, 111, 121, 123, 129–133, 143, 151–161, 168, 172, 173, 180, 185, 187, 190, 203–206, 208, 210, 211
  - Kiunguja, 50
  - Tanzanian Mainland dialects, 50
- Taveta, 13
- thematic hierarchy, 74
- Tswana, 6, 76, 77
- Tunen, 57
- Zigula, 14
- Zulu, 42, 43, 52, 54, 59, 64, 65, 67, 70, 162, 163, 165, 168–170, 176, 180, 181

---

## Samenvatting in het Nederlands

---

Dit proefschrift bestudeert objectmarkering in het Sambia en de Bantoetalen in het algemeen vanuit een syntactisch oogpunt. De discussie richt zich op de vergelijking van de morfosyntaxis van objectmarkering en de syntaxis van objecten in het Sambia, het Haya en het Swahili. Er wordt betoogd dat in alledrie deze talen de objectmarkeerder wordt ingevoegd door de syntactische operatie *Agree*, zoals in Chomsky (2000, 2001). Dit proefschrift verwerpt het idee van Bresnan en Mchombo (1987) dat de Bantoetalen te verdelen zijn in twee types, congruentietalen en pronominale talen, uitgaande van hun objectmarkering. De voors en tegens van dit standpunt worden besproken met betrekking tot diverse data en syntactische omgevingen en de conclusie is dat *Agree* met enige veranderingen alle patronen kan verklaren. Het eerste hoofdstuk geeft een inleiding in het Sambia en de volgende hoofdstukken bespreken de objectmarkering, eerst beschrijvend en dan vanuit de syntactische theorie. In de laatste drie hoofdstukken ligt de focus op objectmarkering in specifieke syntactische constructies en omgevingen.

Hoofdstuk 3 bespreekt de syntaxis van objectmarkering in een aantal Bantoetalen. De criteria voor objectmarkering worden onderzocht, alsook de criteria voor objectmarkeerders in specifieke talen. Een aantal gebieden van de morfosyntaxis wordt behandeld, waaronder de conjoint/disjunct alternantie, (a)symmetrie, constructies met meer dan een object, hiërarchieën, de woordvolgorde en dislocatie naar rechts. De eigenschappen die een lokaal object definiëren worden vastgesteld aan de hand van de gegevens uit het Sambia. Hoewel het Haya niet veel van deze eigenschappen bezit, is er geen bewijs dat de gemarkeerde objecten in het Haya dislocatie naar rechts hebben ondergaan.

Hoofdstuk 4 bespreekt de theoretische uitwerking van de in hoofdstuk 3 voorgestelde zienswijze op objectmarkering in Bantoetalen. Het beschrijft eerst het syntactische proces van *Agree* (Chomsky 2000, 2001). Objectmarkering in de Bantoetalen Sambia, Swahili en Haya kan beschreven worden met *Agree*, wat hier gezien wordt als een relatie tussen een *Probe* en een *Goal* in een *c*-commandeerrelatie. De *Probe* zoekt in zijn *c*-command domein en congrueert met het eerste *Goal* dat erbij past. Hi-

erbij wordt Julien (2002) gevolgd, waar elk morfologisch afzonderlijk element in het Sambia werkwoord behandeld wordt als een syntactisch hoofd.

(1)

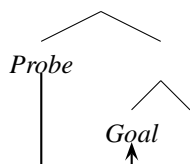

In het Sambia is objectmarkering niet verplicht voor alle soorten objecten. Voor sommige soorten objecten is het echter wel verplicht en de objectmarkering moet zichtbaar zijn in deze situaties. Of objectmarkering vereist is of niet hangt af van de syntactische positie van het object en van zijn eigenschappen. In voorbeeld (2) is *Juma* het directe object van een enkelvoudig transitief werkwoord en het is een eigennaam. In deze situatie is objectmarkering verplicht.

(2) a. N-      za-      mw-    ona Juma.  
SM1S- PERF.DJ- OM1- see 1Juma  
'Ik heb Juma gezien.'

b. \* N-      za-      ona Juma.  
SM1S- PERF.DJ- see 1Juma  
Int: 'Ik heb Juma gezien.'

[Sambia]

In voorbeeld (3) is objectmarkering echter optioneel.

(3) N-      za-      (mw)-    ona ng'wana.  
SM1S- PERF.DJ- OM1- see 1child  
'Ik heb het kind gezien.'

[Sambia]

Om dit te verklaren wordt gesteld dat een *Probe* alleen actief is wanneer de morfologie van de objectmarkering, uitgespeld in de AgrO projecties, aanwezig is in de numeratie. Het zal dan altijd congrueren met het bijpassende element dat het dichtstbij is in het c-command domein. Dit is gerelateerd aan de geobserveerde hiërarchieën voor de beschikbaarheid van objectmarkering in Sambia en aan de verplichte objectmarkering. Zo kunnen er geen objectmarkeerders bestaan die fonologisch nul zijn, vanwege de localiteitsschendingen die naar voren komen wanneer *Agree* een relatie aangaat met een ander *Goal* dan wat het dichtstbij is, of wanneer een object dat verplicht een objectmarkeerder moet hebben niet gemarkeerd is. Een *Probe* heeft altijd een actief kenmerk, maar slechts een kleine subklasse van *Goal*-objecten hebben een actief kenmerk. Deze actieve kenmerken zorgen ervoor dat bepaalde objecten, zoals de eigennaam *Juma* in (2), verplicht een objectmarkeerder hebben. Er wordt gesuggereerd dat dit een referentieel kenmerk is. Ook constructies met meerdere objecten en mogelijk meerdere objectmarkeerders worden besproken voor het Sambia. Hieruit komt naar voren dat *Agree* onderworpen is aan een strikte localiteitsvoorwaarde: *Agree* dichtstbij. Als een werkwoord meerdere objectmarkeerders heeft, bevinden die zich in meerdere

*Agree*-projecties, die elk congrueren met het passende *Goal* dat het dichtstbij is. Op het moment dat een *Goal* een *Agree*-relatie is aangegaan, wordt het onzichtbaar. De overgebleven actieve *Probes* kunnen congrueren met het volgende *Goal* dat nu het dichtstbij is. Dit is geïllustreerd in (4). *Agree* is mogelijk met alleen het indirecte object, dat het dichtstbij is (4a). *Agree* met alleen het directe object is ongrammaticaal (4b), omdat er een *Goal* dichterbij is, namelijk *ng'wana* 'kind', het indirecte object. Als echter het indirect object een *Agree*-relatie is aangegaan, dan is *Agree* met het directe object ook mogelijk, zoals in (4c). Wat betreft de localiteit maakt dit *Agree* in Sambia aantrekkelijker dan het systeem van Chomsky (2000, 2001).

- (4) a. N-    za-        m-    ghulia   ng'wana kitabu.  
       SM1S- PERF.DJ- OM1- buy.APPL 1child 7book  
       'Ik heb een boek voor het kind gekocht.'
- b. \* N-    za-        chi- ghulia   ng'wana kitabu.  
       SM1S- PERF.DJ- OM7- buy.APPL 1child 7book  
       Int: 'Ik heb een boek voor het kind gekocht.'
- c. N-    za-        chi- m-    ghulia   ng'wana kitabu.  
       SM1S- PERF.DJ- OM7- OM1- buy.APPL 1child 7book  
       'Ik heb een boek voor het kind gekocht.'
- [Sambia]

Voor Haya en Swahili kan hetzelfde systeem worden gebruikt, met twee aanvullende syntactische regels. Haya vertoont effecten van *Equidistance*, die het Sambia en Swahili niet hebben. Swahili wijkt af van de andere twee talen omdat het slechts een objectmarkeerder toestaat. Omdat dubbele objecten in alledrie de talen aantoonbaar dezelfde c-commandeerrelaties hebben, zijn de extra regels benodigd. *Equidistance* (Chomsky 2000) maakt het problematisch om één enkele analyse voor Sambia en Haya aan te nemen voor objectmarkering in termen van *Agree*. Alternatieve analyses, zoals de hoofdverplaatsingsanalyse, kunnen echter de grammaticale data niet verklaren die worden gevonden in het Sambia, Haya en andere Bantoetalen met markering van meerdere objecten. In deze talen is er congruentie met objecten in de volgorde van hun hiërarchische toegankelijkheid voor de *Probe*. Een analyse die objectmarkeerders ziet als tussengevoegde clitics loopt tegen dezelfde problemen aan als de *Agreement*-analyse. De oplossing die hier wordt voorgesteld is om van *Equidistance* een geparametriseerde regel te maken. Zo wordt toegestaan dat Haya wel *Equidistance* heeft, terwijl andere Bantoetalen, zoals het Sambia en Swahili, dat niet hebben.

Op dezelfde manier wordt er beargumenteerd dat een element dat al een congruentierelatie is aangegaan de congruentie met het volgende lagere element niet blokkeert in Sambia. In Swahili lijkt dit echter wel het geval te zijn, omdat de objectmarkeerder alleen met het hoogste object kan congrueren. Met de *Defective Intervention Constraint* kunnen alle soorten van congruerende objecten in het Swahili op dezelfde manier worden verklaard.

Hoofdstuk 5 bespreekt de effecten van de *Person Case Constraint* (PCC) op objectmarkering in verscheidene Bantoetalen. Deze PCC-effecten zijn erg systematisch in de hele taalfamilie. De PCC wordt altijd gerespecteerd, onafhankelijk van het aantal toegestane objectmarkeerders en nog los van de vraag of een taal objectmarkeerders

heeft. De data uit de Bantoetalen breiden de toepasbaarheid van de PCC uit van “zwakke indirecte objecten” (Bonet 1991, 1994) naar elk type indirect object. De gepresenteerde data rechtvaardigen een splitsing van de PCC in twee versies, zwak en sterk, omdat de schendingen van de sterke PCC zeer robuust zijn en verspreid zijn over een aantal talen in een groot geografisch gebied.

Hoofdstuk 6 geeft een overzicht van de patronen van objectmarkering in de omgeving van vraagwoorden. In *wh*-vragen blijkt objectmarkering veel meer beperkt te zijn dan in andere omgevingen in Bantoe. Het sterkste contrast in de besproken data is dat tussen de patronen van het Swahili en Sambia aan de ene kant en Haya aan de andere. Deze patronen komen echter niet overeen met de tests voorgesteld in de literatuur voor het verschil tussen congruentie en pronomen (Bresnan en Mchombo 1987; Henderson 2006). Dit proefschrift laat zien dat de verschillende patronen verklaard kunnen worden door de samenstelling van kenmerken van de objectmarkeerder in het Haya. Sambia en Haya hebben een structurele *Immediate After Verb* (IAV) positie waar de *wh*-elementen heen verplaatsen.

Hoofdstuk 7 bespreekt congruentiepatronen bij gecoördineerde naamwoorden. Als het gaat om congruentie met gecoördineerde structuren gedragen Haya en Sambia zich steeds hetzelfde: met preverbale elementen is alleen congruentie met het geheel toegestaan, maar met postverbale elementen is gehele of gedeeltelijke congruentie mogelijk. De analyse van Johannessen (1998) kan deze data niet verklaren. Het feit blijft echter problematisch dat congruentie met het tweede conjunct grammaticaal is in het Swahili. Voor het grootste gedeelte passen de data die in hoofdstuk 7 besproken worden in de analyse van van Koppen (2005) over congruentie met gecoördineerde naamwoorden in verschillende dialecten van het Nederlands. De manier waarop objectmarkering werkt in gecoördineerde naamwoorden vormt een argument voor een analyse in termen van *Agree* om verschillende redenen. Ten eerste omdat subjectmarkering, dat over het algemeen beschouwd wordt als een vorm van congruentie, en objectmarkering zich op dezelfde manier gedragen. Ten tweede omdat verplaatsing vanuit een conjunct van een gecoördineerde structuur, bijvoorbeeld voor incorporatie of enclitatie, onmogelijk zou zijn onder de *Coordinate Structure Constraint* (Ross 1967). Ten slotte wijzen de sterke effecten van volgorde en locatie op de mogelijke patronen op een nauwe c-commandeerrelatie tussen het object en de plaatshouder van de objectmarkeerder.

---

## Muhtasari

---

Tasnifu hii inachunguza ujitokezaji wa yambwa katika lugha ya Kisambaa na lugha nyingine za kibantu, kwa mtazamo wa kisintaksia. Mjadala umekitwa katika kulinganisha mofosintaksia ya ujitokezaji wa yambwa na sintaksia ya yambwa katika Kisambaa, Kihaya na Kiswahili. Inaelezwa kwamba, kiwakilishi cha yambwa katika lugha zote tatu huchopekwa kwa kutumia michaka ya kisintaksia ya upatanisho kulingana na Chomsky (2000, 2001). Wazo kwamba lugha za kibantu zinaweza kugawanywa katika makundi ya aina mbili kutokana na jinsi zinavyotambulisha yambwa, yaani lugha za upatanisho wa kisarufi au lugha za uwakilishi wa nomino kama ilivyo-elezwa na Bresnan and Mchombo (1987), limekataliwa. Hoja za kukubali na kukataa mtazamo huu zimejadiliwa kwenye data pamoja na mazingira mapana ya kisintaksia na kuhitimishwa kwamba upatanisho wa kisarufi unaweza kuelezea mielekeo yote mitatu huku kukiwa na marekebisho machache katika sehemu zake ndogo ndogo.

Sura ya kwanza inatoa utangulizi kuhusu lugha ya Kisambaa. Sura zinazofuatia zinajadili ujitokezaji wa yambwa, kwanza kwa njia ya fafanuzi, na kisha kwa nadharia za kisintaksia. Sura tatu za mwisho zinalenga kuelezea ujitokezaji wa yambwa katika mipangilio mahususi na miktadha ya kisintaksia.

Sura ya 3 inajadili sintaksia ya ujitokezaji wa yambwa katika lugha kadhaa za kibantu. Vigezo mahususi vya lugha za kibantu kuhusu yambwa pamoja na vya sifa za alama ya kutambulisha yambwa katika lugha maalum vimechunguzwa. Maeneo mbalimbali ya mofosintaksia ya kibantu yamejadiliwa, ikijumuisha ubadilishaji wa konjoints/disjoints, urari, tungo zenye yambwa mbili, misonge, ukweli kuhusu mpangilio wa maneno na utenguzi wa kutoka kulia. Kwa kutumia data ya Kisambaa, sifa mahususi zinazoainisha yambwa husika zimeelezwa. Inaonyeshwa kwamba, japokuwa Kihaya hakijitoshelezi katika mengi ya haya, hakuna ushahidi kuwa yambwa zinazotambulishwa na alama ya yambwa katika Kihaya zimetenguliwa kutoka kulia.

Sura ya 4 inajadili utekelezaji wa kinadharia wa maoni ya ujitokezaji wa yambwa katika lugha za kibantu yaliyoelezwa kwenye sura ya 3. Michakato ya kisintaksia ya upatanisho wa kisarufi (Chomsky 2000, 2001) imeelezwa. Kufuatana na Julien (2002), kila elementi ya kimofolojia katika kitenzi cha Kisambaa imechukuliwa kama neno kuu kisintaksia. Lugha za kibantu, ambazo ni Kisambaa, Kiswahili na Kihaya

zimeelezwa kuwa na upatanifu wa kisarufi katika yambwa. Upatanisho wa kisarufi kama ilivyochukuliwa hapa ni uhusiano kati ya kitafutaji (*Probe*) na kikomo (*Goal*) uliopo kwenye c-komandi. Kitafutaji hutafuta masikani yake na kupatana na kikomo cha kwanza kinachooana nacho.

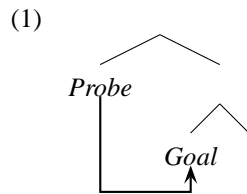

Katika Kisambaa, kiwakilishi cha yambwa si cha lazima kwenye aina zote za yambwa. Hata hivyo, kiwakilishi cha yamba kwenye aina fulani za yambwa unahitajika na katika mazingira haya ni lazima kiwakilishi cha yambwa iwe wazi. Inaoneshwa kuwa, kuhitajika au kutohitajika kunategemeana na nafasi ya kisintaksia ya yambwa na sifa ilizonazo. Kwa kuangalia mfano wa (2), *Juma* ni yambwa ya mtendwa ya kitenzi-elekezi na ni jina la pekee. Katika muktadha huu, ujitokezaji wa yambwa ni wa lazima.

- (2) a. N-        za-        mw-    ona Juma.  
 SM1S- PERF.DJ- OM1- see 1Juma  
 'Nilimwona Juma.'
- b. \* N-        za-        ona Juma.  
 SM1S- PERF.DJ- see 1Juma  
 Int: 'Nilimwona Juma.' [Kisambaa]

Hata hivyo, kwenye (3), ujitokezaji wa yambwa si wa lazima.

- (3) a. N-        za-        (mw)-    ona ng'wana.  
 SM1S- PERF.DJ- OM1- see 1child  
 'Nilimwona mtoto.' [Kisambaa]

Katika kufafanua hili inaelezwa kwamba, kitafutaji kinakuwa tu hai pale ambapo morfologia ya kiwakilishi cha yambwa, iliyooneshwa kinagaubaga kwenye projeksheni za upatanisho wa kisarufi wa yambwa (AgrOP), inapokuwepo kwenye idadi ya yaliyomo kwenye sentensi fulani, na mara zote itapatana na elementi ya karibu inayooana nayo na iliyotabiriwa na elementi ya juu. Hii inahusiana na misonge iliyotambuliwa ya ujitokezaji wa yambwa inayopatikana katika lugha ya Kisambaa na ujitokezaji wa lazima wa kiwakilishi cha yambwa. Imeelezwa kwamba, hakuna alama ya yambwa kapa za kifonolojia kutokana na ukiukwaji wa nafasi unaotokea wakati upatanisho wa kisarufi unapoiingia kwenye uhusiano na chochote zaidi ya kikomo karibu zaidi, au pale ambapo yambwa inayohitaji kutambulishwa haikutambulishwa. Inaelezwa kuwa, mara nyingi kitafutaji kinakuwa na elementi hai na ni sehemu ndogo tu ya aina za yambwa kikomo zenye elementi ya uhai. Hizi husababisha baadhi ya yambwa, kama jina la

pekee *Juma* kwenye mfano (2), kuhitaji kutambulishwa. Inapendekezwa kwamba sifa ya urejeshi ndio sifa inayohitajika.

Tungo zenye yambwa zaidi ya moja na alama nyingi muhimu za kutambulisha yambwa katika kisambaa zimejadiliwa huku ikioneshwa kuwa upatanisho wa kisarufi unafaa kwenye maeneo maalum tu: kupatana na ya karibu zaidi. Pale ambapo kitenzi kinaonyesha alama za yambwa zaidi ya moja imeelezwa kwamba zimebebwa na projeksheni nyingi za upatanisho wa kisarufi, kila moja ikipatana na kikomo chake cha karibu zaidi. Kikomo kinapoingia kwenye uhusiano wa kiupatanisho huwa hakionekani, na kitafutaji chochote hai kilichobaki kinaweza kupatana na kikomo cha karibu zaidi. Hii inaoneshwa kwenye (4). Upatanisho na yambwa tendewa tu, yaani kikomo cha karibu zaidi, inawezekana kama inavyoonyeshwa katika (4a). Upatanisho na yambwa tendewa tu, kama ilivyoonyeshwa kwenye (4b) sio sahihi kisarufi. Hii ni kwa sababu kuna kikomo cha karibu zaidi *ng'wana* 'mtoto', ambayo ni yambwa tendewa. Hata hivyo, baada ya yambwa tendewa kuingia kwenye uhusiano wa kiupatanisho, kupatana na yambwa tendewa inawezekana. Hii imeonyeshwa kwenye (4c).

- (4) a. N- za- m- ghulia ng'wana kitabu.  
SM1S- PERF.DJ- OM1- buy.APPL 1child 7book  
'Nilimnunulia mtoto kitabu.'
- b. \* N- za- chi- ghulia ng'wana kitabu.  
SM1S- PERF.DJ- OM7- buy.APPL 1child 7book  
Int: 'Nilimnunulia mtoto kitabu.'
- c. N- za- chi- m- ghulia ng'wana kitabu.  
SM1S- PERF.DJ- OM7- OM1- buy.APPL 1child 7book  
'Nilimnunulia mtoto kitabu.'
- [Kisambaa]

Kwa kuzingatia ukaribu, upatanisho wa kisarufi katika Kisambaa unaonekana bayana zaidi kuliko mfumo uliolezwa na Chomsky (2000, 2001).

Katika Kihaya na Kiswahili, mfumo huo huo ukiongezwa na kanuni mbili za kisintaksia umependekezwa. Hizi zinahitajika kwa sababu Kihaya kinaonesha athari za umbalisawa (*Equidistance*) wakati Kisambaa na Kiswahili hazioneshi hivyo, wakati huo huo Kiswahili hakiruhusu ujitokezaji wa yambwa zaidi ya moja. Hii inahitajika kwa sababu yambwa mbili katika lugha zote tatu kuonyesha kuwa na uhusiano unao-fanana wa c-komandi. Umbalisawa (Chomsky 2000), ni eneo lenye matatizo kwa uchanganuzi wa upatanisho wa kisarufi wa yambwa katika Kisambaa na Kihaya. Hata hivyo imeoneshwa kuwa changanuzi mbadala kama vile uchanganuzi wa uhamishaji wa neno kuu hauwezi kuelezea data ya kisarufi katika Kisambaa, Kihaya au lugha yoyote ya kibantu inayoruhusu ujitokezaji wa yambwa mbili, ambapo yambwa hu-patanishwa katika mpangilio wake wa msonge hadi kukifikia kitafutaji. Uchanganuzi wa uchopekaji kiangami umeonekana kuwa na tatizo moja sawa na uchanganuzi wa upatanisho wa kisarufi. Imeelezwa kuwa suluhisho la tatizo hili ni kuufanya umbali-sawa kuwa kanuni ya kiparameta. Hii inaruhusu Kihaya kuwa na umbalisawa, wakati lugha nyingine za kibantu kama Kisambaa na Kiswahili hazina.

Imeelezwa pia kuwa wakati elementi moja katika Kisambaa inapopatana nayo haizuii kupatana na elementi ya chini inayofuatana nayo. Hata hivyo, katika Kiswahili

hii hutokea pia kwani ni yambwa ya juu zaidi tu inayoweza kupatanishwa. Kwa kutumia *Defective Intervention Constraint* kuelezea hili, imetusaididia kuelezea kwa namna moja aina zote za yambwa zinazopatanishwa katika Kiswahili.

Katika sura ya 5, athari za *Person Case Constraint* (PCC) katika kutambulisha yambwa katika lugha nyingi za kibantu zimejadiliwa ambapo imeonyeshwa kuwa athari za PCC hujitokeza katika utaratibu maalumu sana katika familia nzima ya lugha za kibantu. Bila kuzingatia idadi ya yambwa zinazoruhusiwa, au kama lugha hutambulisha yambwa, athari za PCC dhaifu daima huzingatiwa. Data kutoka kwenye lugha za kibantu imepanua utekelezaji wa athari za PCC zaidi ya kile Bonet (1991, 1994) alichokiita “yambwa tendwa dhaifu” katika aina yoyote ya yambwa tendwa. Data iliyowasilishwa inaunga mkono kwa nguvu ugawanywaji wa athari za PCC katika matoleo mawili kwa sababu ukiukwaji wa athari za PCC yenye nguvu ni mkubwa sana na umeenea sana kwenye lugha zinazozungumzwa katika eneo kubwa kijiografia.

Sura ya 6 inapitia ruwaza za ujitokezaji wa yambwa inayopatikana katika mukadha wa maswali ya *wh*. Inaonyeshwa kwamba katika maswali ya *wh* utambulisho wa yambwa ni finyu sana ikilinganishwa na mazingira mengine katika lugha za kibantu. Data iliyojadiliwa kwenye sura hii inaonyesha tofauti kubwa baina ya ruwaza inayopatikana katika Kiswahili na Kisambaa kwa upande mmoja, na Kihaya kwa upande mwingine. Hata hivyo, ruwaza hizi hazioani na majaribio ya upatanisho wa kisarufi ama uwakilishi wa nomino yaliyopendekezwa kwenye marejeo (Bresnan and Mchombo 1987; Henderson 2006b). Inaelezwa kwamba tofauti hizi zinaweza kuelezewa kwa kutumia nduni zilizomo katika kiwakilishi cha yambwa katika Kihaya. Kisambaa, na kwa kuongezea, Kihaya zinaelezwa kuwa na nafasi ya muundo wa *Immediate After Verb Position* (IAV) ambapo elementi za maswali ya *wh* huhamia.

Katika sura ya 7, ruwaza za upatanisho wa kisarufi wenye vikundi nomino ambatani imejadiliwa. Kuhusiana na upatanisho wa kisarufi kwenye miundo ambatani, Kihaya na Kisambaa zimeoneshwa kufanana sana, katika kuruhusu upatanisho kamili katika viambishi awali kwenye kitenzi huku zikiruhusu upatanisho kamili au usio kamili wa viambishi tamati katika kitenzi. Imeoneshwa kwamba uchanganuzi wa Johannesssen (1998) hauwezi kuelezea data ya kibantu. Hata hivyo, hoja kwamba upatanisho wa pili wa miambatano katika Kiswahili ni sahihi kisarufi bado una maswali. Kwa sehemu kubwa data kutoka kwenye lugha zilizojadiliwa kwenye sura ya saba inaoana na kile kilichojadiliwa na van Koppen (2005), kuhusu upatanisho na kikundi nomino ambatani katika lahaja mbalimbali za Kiholanzi. Namna ambavyo utambulisho wa yambwa unavyofanya kazi katika miundo ambatani inaunga mkono uchanganuzi wa kuzingatia upatanisho kutokana na sababu mbalimbali. Kwanza ni kwamba, ujitokezaji wa kiima, ambao daima umechukuliwa kuwa unanyambulishwa na upatanisho wa kisarufi, na ujitokezaji wa yambwa una tabia za kufanana. Pili, kwa sababu uhamishaji, kwa mfano kwa ugubikaji au kwa kuangamisha nje ya kiunganishi kimoja cha muundo ambatani hakitawezekana kwenye *Coordinate Structure Constraint* (Ross 1967). Mwisho, athari kubwa za mpangilio na mazingira kwenye ruwaza zinazoweza zinaunga mkomo uhusiano wa c-komandi ya karibu kati ya yambwa na kipokeaji cha alama ya yambwa.

---

## Curriculum Vitae

---

Kristina Riedel was born in Berlin, Germany on 13 April 1980. In 1998, she started studying Development Studies and Swahili at the School of Oriental and African Studies (SOAS) in London. Focussing on African languages and linguistics, she graduated with a BA degree in African Language and Culture (Swahili) with first class honours in 2002. From 2002 to 2003, she completed an MA degree in Linguistics at SOAS, with a dissertation on resumptive pronouns in Swahili. In 2003, she joined the Advanced Masters Programme in Linguistics at the University of Leiden. In 2004, she started to work towards her PhD as a member of the NWO project “Word order and morphological Marking in Bantu” at the University of Leiden. She is currently employed as a postdoctoral researcher at the Zentrum für Allgemeine Sprachwissenschaft (Centre for General Linguistics) in Berlin.