



Universiteit
Leiden
The Netherlands

Knocking on surfaces : interactions of hyperthermal particles with metal surfaces

Ueta, H.

Citation

Ueta, H. (2010, November 16). *Knocking on surfaces : interactions of hyperthermal particles with metal surfaces*. Retrieved from <https://hdl.handle.net/1887/16153>

Version: Corrected Publisher's Version

License: [Licence agreement concerning inclusion of doctoral thesis in the Institutional Repository of the University of Leiden](#)

Downloaded from: <https://hdl.handle.net/1887/16153>

Note: To cite this publication please use the final published version (if applicable).

Chapter 1

Introduction

1.1 General introduction

Gas-surface interactions are central to numerous natural and industrial processes. Examples include heterogeneous catalysis, thin film growth by chemical vapour deposition, sputtering, etching and corrosion. In addition, gas-surface interactions play an important role in energy conversion and environmental processes. A detailed understanding of such gas-surface interaction dynamics is therefore not only of fundamental interest, but also important for the development of various applications. Such basic studies are also essential for the validation of computer codes, in which the fundamental processes play an essential role and cannot be benchmarked by comparison to complex “real world” situations. Detailed understanding at the atomic level is not easy to obtain because of the variety of phenomena that may occur simultaneously under application conditions. Therefore, in order to explore the microscopic details of gas-surface interaction, well-defined conditions are a prerequisite. Model systems are studied in order to provide knowledge beneficial in fully understanding “real” systems [1-3]. This is the approach adopted in the field of ultrahigh vacuum (UHV) surface science. The value of this approach has been recognised in the awarding of the 2007 Nobel Prize in chemistry to Prof. Dr. G. Ertl for his work in this field [4].

As a first step in a gas-surface interaction, molecules may stick atomically and/or molecularly when they impinge on the surface if the system is sufficiently reactive. If it is not, they will be reflected (scattered). To study chemical reactions at a surface, a range of surface sensitive tools can be used in order to measure changes to the surface conditions before and after gas exposure. An alternative (complementary) approach is to “ask” particles leaving the surface what conditions they encountered, since they experienced the surface directly. This involves the study of scattering/desorption, which is the approach adopted in this thesis. The work mainly deals with scattering dynamics, hence the title: “Knocking on Surfaces”.

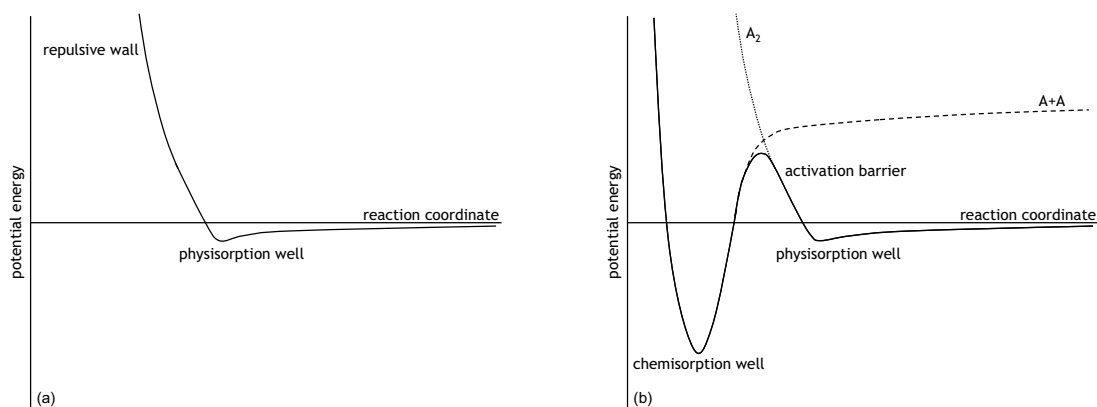

Figure 1.1 Simplified one-dimensional potential energy diagrams of (a) nonreactive-particle- and (b) molecule-surface interaction potential. Two potentials are shown, the one with the shallow well represents physisorption, and the other (deep well) represents chemisorption.

The nature of the interaction of gas particles with a surface varies strongly with the energy of the incident particle. The energy regime being investigated dictates the instrumentation utilized for a particular study. Molecular beam sources can be used to control and vary the translational energy of a species impinging on a surface by up to a few eV (or a few hundreds of kJ/mol). Ion beams have been used to probe interactions at energies ranging from ~ 50 eV through the keV and MeV regimes. However, the gap between these two energy regimes is not easy to access. Well-focussed ion beams are difficult to produce at low energies, while producing neutrals with energies more than a few eV is also non-trivial. This thesis mainly deals with that intermediate energy regime (hyperthermal energy). We introduced a cascaded arc plasma source, which generates hyperthermal particles, into UHV surface science. Using the combination of this source and molecular beam techniques we were able to probe gas-surface interaction in the 1-10 eV energy regime. The interaction of particles in this energy range with surfaces may be relevant in situations as diverse as real catalytic reactions at industrial high pressure and temperature conditions, fusion reactor wall erosion and the aerodynamic drag on an object moving through the upper atmosphere.

Figure 1.1 shows simplified one-dimensional potential energy diagrams of “typical” gas-surface interaction. The interaction between a non-reactive gas and a surface involves a shallow physisorption well and a repulsive wall, as is illustrated in figure 1.1(a). With increasing translational energies the incident particle will scatter from points higher on the repulsive wall of the interaction potential, which are closer to the surface atomic cores, but the interaction remains repulsive (the physisorption well is only significant if the incident particles have a very low initial energy). As the energy increases incident particles will see an increasingly more corrugated potential energy surface. The individual surface atoms become individually distinguishable by the incident particles at sufficiently high energy. Figure 1.2 shows cross-sections of the potential energy surfaces for the repulsive Ar-Ag(111) system [5]. The atoms in the outermost layer become “individually” distinguishable to Ar atoms incident with energies greater than 30 eV. The precise energy at which this occurs is dependent on

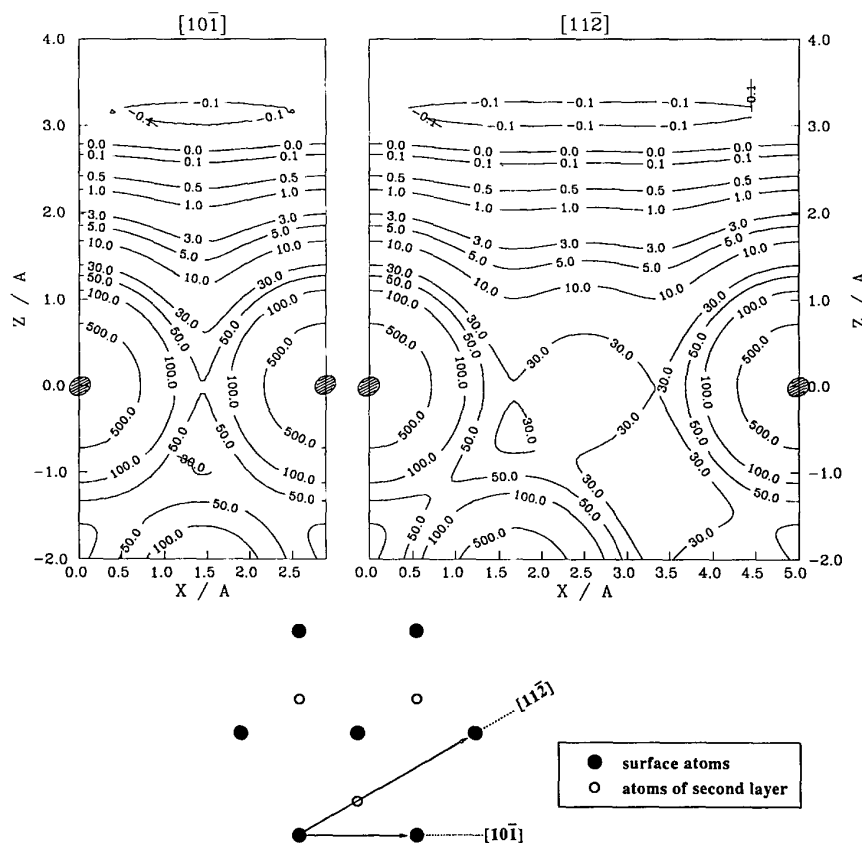

Figure 1.2 The upper two panels show the contour plots of the Ar—Ag(111) potential energy surface along two azimuth orientations of the surface. X is the line along the surface and Z is the height to the surface plane. Distances are in \AA and the contour values in eV. Underneath a small surface unit cell is drawn to indicate the two azimuthal orientations. The figure is taken from ref. [5].

the azimuthal direction being probed. Along the more open directions, the individual atoms become evident at a lower projectile energy. Hence, hyperthermal particles are capable of probing local atomic structure [6].

When the corrugation due to the individual surface atoms appears, surface rainbows may be observed [7]. Rainbow scattering is a focussing effect of classical scattering behaviour. Certain scattering trajectories are focussed along certain scattering angles depending on the shape of potential energy surface. Figure 1.3 shows an example of rainbow scattering peaks that appear in calculations of Ar scattering from Ag(111) [5]. The rainbow features are clearly seen as sharp features in the calculated angular distributions (e.g. the peaks at 35° and 55° for 1 eV are surface rainbow peaks) from the static (frozen) surface. These features are absent from simulations done at a surface temperature of 600 K. Thermal motion of the surface atoms disrupts the focussing effect.

When the incident particles are reactive atoms or molecules, the situation becomes more complex due to the additional possibility of chemisorption interactions. For dissociative adsorption of molecules, an activation barrier may exist due to the necessity of bond breaking prior to adsorption. Figure 1.1(b) shows a schematic energy diagram of such a system. The barrier may be described by different degrees

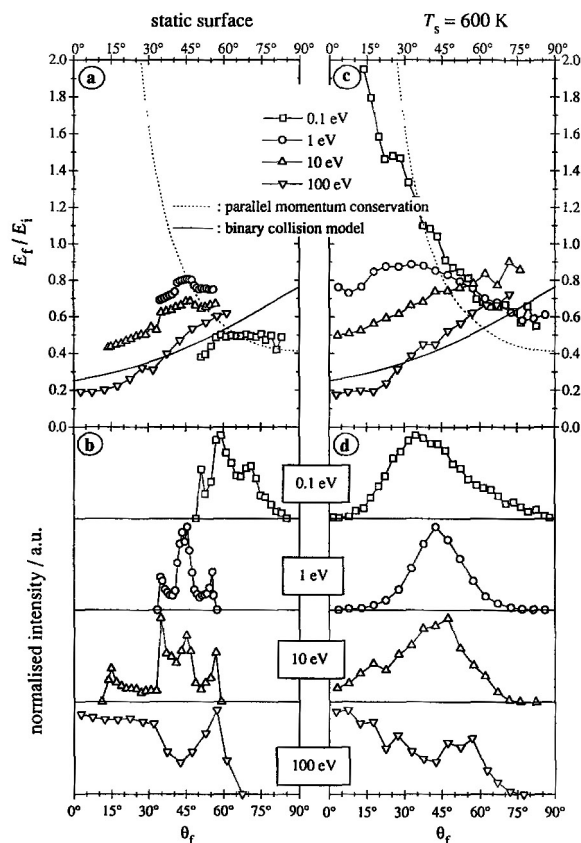

Figure 1.3 Simulations for in-plane scattering of Ar from Ag(111) with an incidence angle of 40° , measured with respect to the surface normal. (a) and (b) correspond to a static surface, (c) and (d) to 600 K. The figure is taken from ref. [5].

of freedom of the particle-surface interaction, such as the particle-surface distance or the molecular bond-length, and adsorption will occur if the impinging particle can overcome this barrier.

Most dissociation processes on surfaces can be divided into one of two general mechanisms, specifically *direct* and *trapping-mediated*. In the direct mechanism, a molecule dissociates upon impact with the surface. In the trapping-mediated mechanism, a molecule collides with the surface inelastically, and then dissipates sufficient energy to avoid prompt desorption. Such a molecule is trapped in a shallow physisorption well or weak chemisorption well. Thermal motion of the surface atoms ensures that the molecule diffuses to a reactive site (such as a step edge or defect site) that efficiently promotes dissociation. Apart from overcoming a surface barrier with sufficient translational energy, adsorption may be enhanced by the thermal motion of the surface atoms [8] and tunnelling through the barrier may also be a possibility [9]. Vibrational excitation of impinging particles may also promote barrier crossing [10-14]. Furthermore, the orientation of a molecule can play an important role in the adsorption process [15-19].

In contrast to molecules, reactive atoms (produced by pre-dissociation) can access the chemisorption well directly without having to overcome a dissociation barrier. As

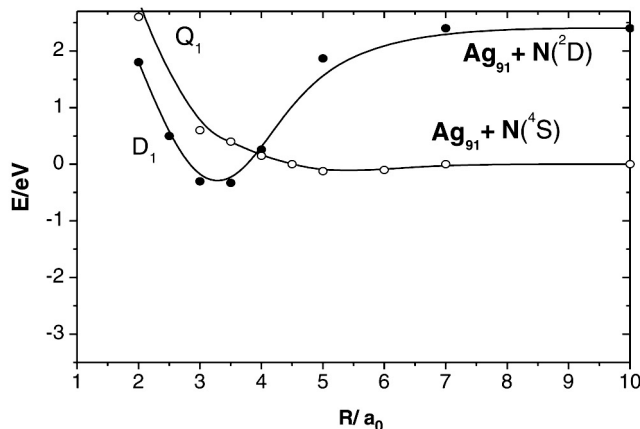

Figure 1. 4 Reactive atom-surface potential energy diagram. Potential energy curves for the ground state $N(^4S)$ — and electronically excited $N(^2D)$ — Ag_{91} clusters (Ag_{91}) interaction are shown. This is adapted from ref. [20]. Details are described in chapter 5.

an example of such systems, computational potentials of N — $Ag(111)$ are shown in figure 1.4 [20]. The 2D state of N has a deep well at the Ag surface. Provided the incident atom loses enough energy during the interaction, it will remain trapped in the adsorption state. Otherwise it will scatter back to gas phase. In contrast, the 4S state of N has a repulsive interaction and will scatter in all cases. However, the picture changes if state changes are allowed during the interaction. Hence, nonadiabatic effects such as spin-state changes [21-25], electron transfer [26-31], and electron-hole pair excitations [32-35] can also play a significant role in gas-surface interaction processes.

Thus far we have focussed on the dynamics of particles impinging on a surface. We now consider reactions with atoms and molecules already on the surface. Reactions at surfaces can generally proceed via two mechanisms, *Langmuir-Hinshelwood* (LH) [36, 37] or *Eley-Rideal* (ER) [38, 39]. In the LH mechanism, atom and molecule adsorb from the gas phase and react to form a product at the surface, which subsequently desorbs. Since those adsorbates are in thermal equilibrium with the surface, the reaction is initiated by the thermal energy of the surface. In contrast, the ER mechanism involves adsorbates reacting directly with an impinging gas particle, and the product formed desorbs instantaneously. There is also an intermediate, so-called hot atom (HA) mechanism [40] in which the impinging particle is trapped at, but not completely equilibrated with, the surface before it reacts with an adsorbate and the resulting product desorbs.

Even when the impinging particle is non-reactive, if it has hyperthermal energy that is of the same order as the chemisorption binding energies of the adsorbates (or higher), then collision-induced chemistry may occur [41, 42]. Alternatively, if the impinging particle deposits its energy very locally on surface, then dynamical displacement is possible [43-45].

1.2 Experimental setup

To understand details of the gas-surface interaction on the molecular level, well-defined conditions are required. For the experiments described in this thesis, the quality of surface is very important since the experiments deal with fundamental properties of the gas-surface interaction. To ensure the uniformity and reproducibility of the surface, experiments are performed at UHV (pressure lower than 10^{-9} mbar). Once in vacuum the sample surface is treated by sputtering with Ar^+ ions, oxygen treatment and annealing to obtain a smooth surface. Ideally, the partner of the surface, the gas particle must also have well-defined collision parameters such as the speed and incident angle of the molecules. For this reason, the dynamics of gas-surface interaction in this thesis are studied using molecular beam techniques. However, even under these conditions the gas-surface reactions remain inherently complex due to the many degrees of freedom involved such as the ro-vibrational quantum state, molecular orientation and the precise impact site on the surface.

The experiments described in this thesis have been carried out in two separate surface science chambers. The experiments in chapter 2, 3, 5 and 6 were done in the scattering apparatus “HARPOEN”, the layout of which is shown in figure 1.5. The experiments in chapter 4 were carried out in the “POTVIS” apparatus, whose schematic configuration is given in figure 1.6.

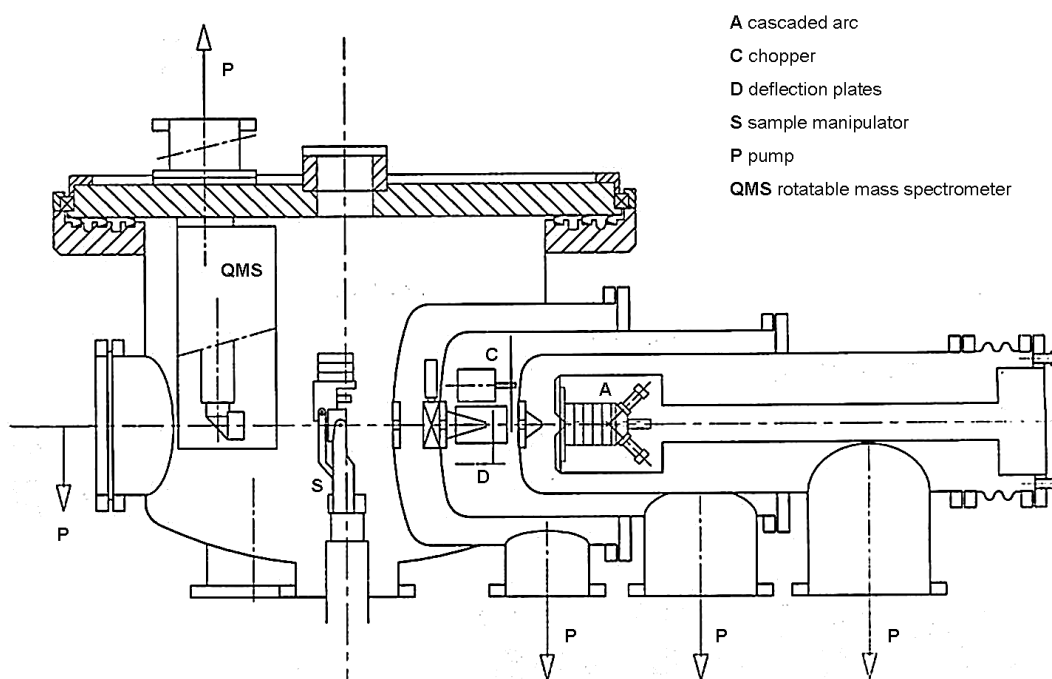

Figure 1. 5 Schematic of HARPOEN. It shows the cascaded arc source, consisting of three pumping stages, entering a UHV chamber in which the sample is mounted on a multi-axis manipulator.

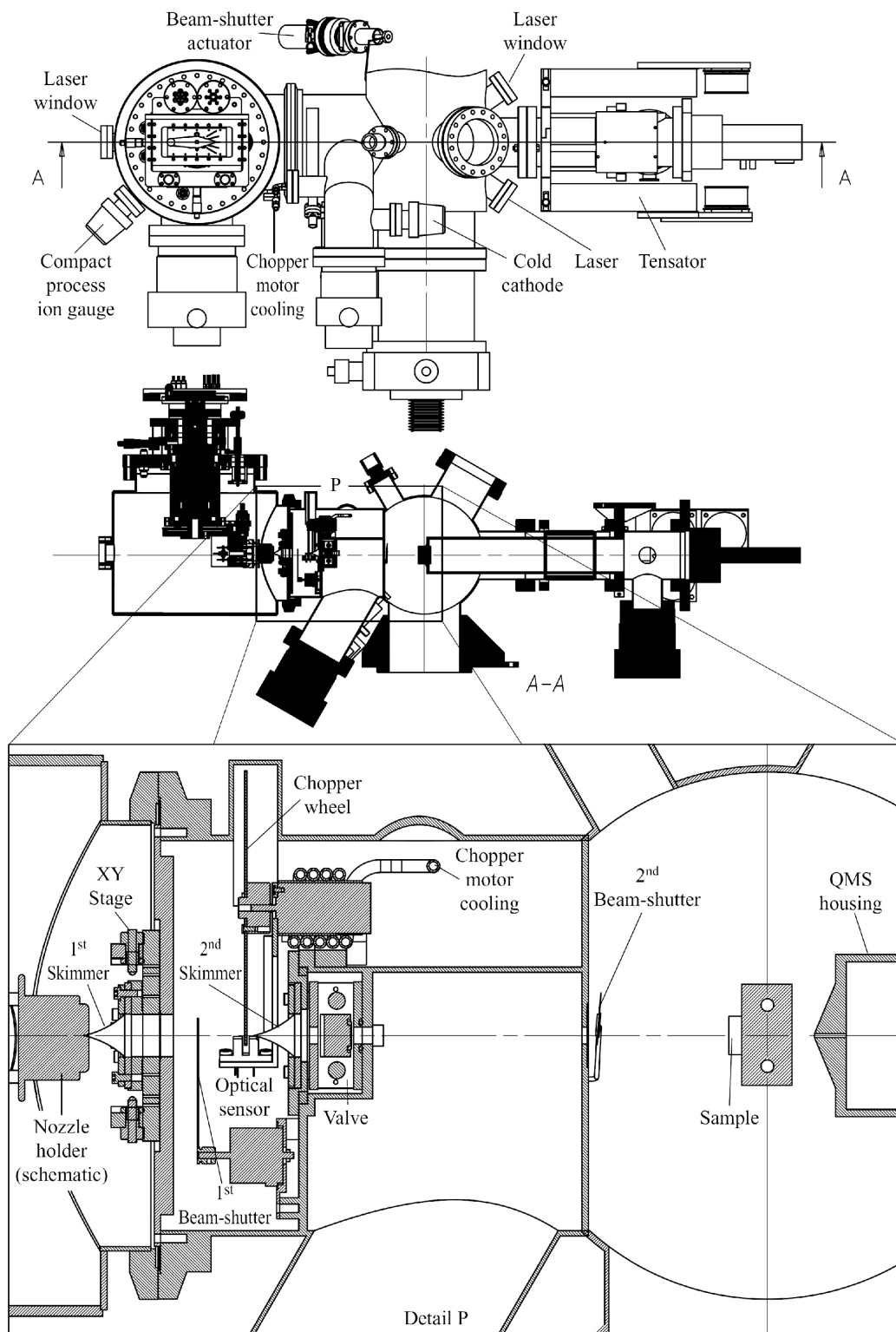

Figure 1. 6 Schematic of POTVIS. This figure is adapted from ref. [46].

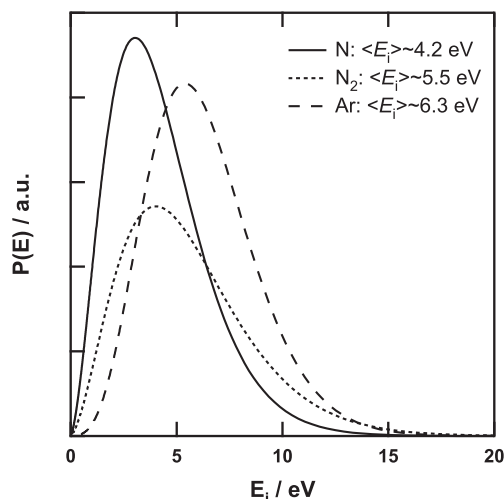

Figure 1. 7 Typical energy distributions of beams which were used in the HARPOEN scattering experiments.

“HARPOEN” is used primarily for scattering experiments. It consists of an UHV vessel with a triply differentially pumped plasma source attached. This machine was previously used in combination with a supersonic molecular beam source [47]. A cascaded arc plasma source has been mounted in place of the molecular beam source [48]. The first stage of the beamline contains the cascaded arc source [49-52]. This produces a wall-stabilised high-density linear plasma. Plasma is initiated by discharge at three symmetrically mounted cathode tips (field-emitting type) and is transported through a channel in a stack of five floating, mutually isolated copper plates. Plasmas are run with a constant current through the arc of ~ 60 A. The plasma expands into the first stage of the beamline. It is collimated using skimmers to yield a beam with low divergence. Two differential pumping stages in the beamline separate the source chamber from the UHV chamber containing the sample, in order to reduce the effusive gas load from the source chamber.

The second stage of the beamline contains a beam flag, a mechanical chopper wheel, and a pair of deflection plates that are used to remove charged particles from the beam. This apparatus allows us to study the interaction between hot particles/radicals and surfaces. In this thesis, beams derived from pure argon and pure nitrogen plasmas are used. The argon beams had an average energy ($\langle E_i \rangle$) of ~ 6 eV, while those of nitrogen contains N with $\langle E_i \rangle$ of ~ 4 eV and N_2 with $\langle E_i \rangle$ of ~ 5.5 eV. Figure 1.7 shows the typical energy distribution of the particles in those beams. The cascaded arc source does not have the well-defined mono-energetic beams that are typical of supersonic molecular beam (see the equivalent POTVIS distributions in figure 1.8).

For the scattering experiments the beam is chopped into pulses of short duration and reflected from the surface. Incident and scattered particles are detected as a function of arrival time using a rotatable differentially pumped quadrupole mass spectrometer (time-of-flight (TOF) measurement). The incident energy, final energy and angular flux distribution of scattered particles are all derived from TOF measurements.

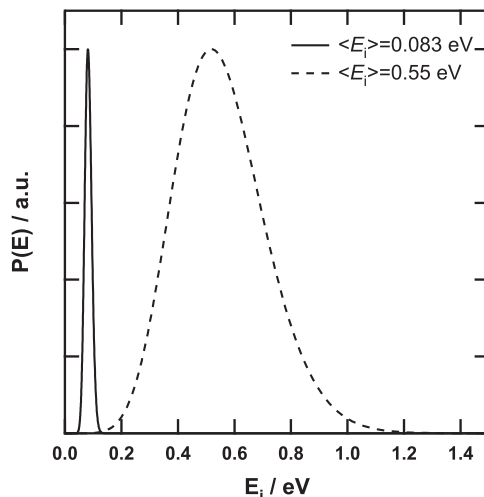

Figure 1. 8 Distributions of the lowest and highest energy beams which were used in POTVIS sticking experiments (chapter 4). The lowest kinetic energy is generated by 100% D_2 with the nozzle at room temperature. The highest kinetic energy beam is generated by D_2 seeded in H_2 ($D_2:H_2=1:2$) with a nozzle temperature of 1700 K.

“POTVIS” is a molecular beam apparatus [46, 53], which is used for sticking experiments in chapter 4. D_2 beams can be produced by supersonic expansion of the gas through a small orifice into vacuum [54]. As the gas expands, the enthalpy is transferred into flow velocity and gas cooling occurs due to the particle collisions. Such a particle velocity distribution is described by the so-called *shifted Maxwell-Boltzmann* distribution. The incident kinetic energy is varied by the nozzle temperature (which changes the gas temperature in the source) and by using gas mixtures since after the supersonic expansion all particles has a roughly equal velocity. For instance, the kinetic energy of a particle is increased (decreased) by mixing it with a lighter (heavier) gas. Energy distributions of the highest and lowest kinetic energy used in this thesis are shown in figure 1.8. Due to poor rotational cooling of D_2 (H_2) during supersonic expansion at high nozzle temperatures [55, 56], our high energy beams have relatively broad translational- and rotational-energy distributions.

Sticking probabilities are measured by monitoring the partial pressure in the system. The ratio of the pressure drop in the system when the beam is allowed to impinge on the sample surface and the partial pressure increase due to the beam entering the system is a measure for the sticking probability. This is the so-called *King and Wells* technique [57, 58].

1.3 This thesis

This thesis “Knocking on Surfaces” can be divided into two parts, based on the two single crystal surfaces, Ru(0001) and Ag(111), that were used. In the first part, clean and adsorbates-covered Ru(0001) surfaces are probed by Ar and D_2 . In the second part, N atoms probe clean and N-covered Ag(111) surfaces. The thesis is structured as follows:

Chapter 2 reports on experiments involving hyperthermal Ar scattering from a clean and D-covered Ru(0001) surfaces. Since Ar is a noble gas atom, it probes the repulsive wall of the interaction potential. By comparison with the results from Ag(111), knowledge of surface topology and stiffness are obtained.

In chapter 3 the scattering of hyperthermal Ar from the CO-covered Ru(0001) surface is described. Similar to chapter 2, the repulsive part of the interaction between gas-surface is the focus. On this surface Ar interacts with the CO molecules and large energy transfers occur. The interaction leads to collision-induced CO desorption.

Chapter 4 presents the dynamics of D₂ dissociation on CO-covered Ru(0001) surfaces. In this chapter not only the repulsive part of interaction but also the chemisorption well is probed. CO blocks D₂ dissociation and perturbs the local surface reactivity up to the nearest-neighbour Ru atoms.

Chapter 5 deals with hyperthermal N atoms scattering from the clean Ag(111) surface. All experiments are done at a surface temperatures greater than 500 K, which is above the recombinative desorption temperature of N₂ [59]. These results are compared with the physisorption system of Ar/Ag(111) revealing the chemisorption dynamics.

Chapter 6 reports on hyperthermal nitrogen interaction with N-covered Ag(111). The experiments are done at 300 K, below the recombinative desorption temperature. This system allows the possibility of reactive atoms interacting with adsorbates, in contrast to chapter 3 which deals with the interaction between a non-reactive gas and adsorbates on the surface.

1.4 Significance

As mentioned above, interactions of hyperthermal particles with surfaces are addressed in this thesis. The bulk of the work involves particles with translational energies that are non-trivial to produce. In addition, part of the work has focussed on a reactive atom (N) that is very difficult to produce in beam form. As such, the current work has endeavoured to push the envelope on the range of energies and particles that can be accessed by experimental means.

Understanding of the amount of energy that an incident particle transfers to a surface during a collision is essential for the accurate modelling of many technologically important processes, including sputtering, plasma etching, and ion implantation. It is also crucial to the estimation of the drag on spacecraft and for the design of nuclear fusion reactor. In the latter case, for example, energy losses from the plasma to the reactor walls have important consequences for the particle and energy balance of the system. Chapter 2, 3, 5 and 6 could contribute to obtaining such understanding.

Chapters 2 and 3 illustrate that hyperthermal noble gas atoms can be used as a tool to probe surface topology and stiffness without inducing damage. Chapter 4 investigates the influence of CO on the hydrogen dissociation reaction, which is relevant to many industrially important processes such as methanation and Fischer-

Tropsch synthesis. The physical displacement investigated in chapter 3 is also interesting in this regard.

Separately, basic research such is presented this thesis contributes to validation of advanced computer models. In fact, chapter 4 has been compared with theoretical calculation [60, 61]. In addition, the content of chapter 5 has stimulated theoretical work that was presented at the recent European Conference on Surface Science (ECOSS-27) [62].

Bibliography

- [1] J.A. Barker, D.J. Auerbach, *Surface Science Reports*, **4** (1984) 1-99.
- [2] G.A. Somorjai, *Introduction to Surface Chemistry and Catalysis*, Wiley, New York, 1994.
- [3] A.W. Kleyn, *Chem Soc Rev*, **32** (2003) 87-95.
- [4] G. Ertl, *Angewandte Chemie International Edition*, **47** (2008) 3524-3535.
- [5] R.J.W.E. Lahaye, A.W. Kleyn, S. Stolte, S. Holloway, *Surface Science*, **338** (1995) 169-182.
- [6] A.D. Tenner, K.T. Gillen, T.C.M. Horn, J. Los, A.W. Kleyn, *Physical Review Letters*, **52** (1984) 2183.
- [7] A.W. Kleyn, T.C.M. Horn, *Phys Rep*, **199** (1991) 191-230.
- [8] J. Hall, O. Saksager, I. Chorkendorff, *Chemical Physics Letters*, **216** (1993) 413-417.
- [9] J. Harris, J. Simon, A.C. Luntz, C.B. Mullins, C.T. Rettner, *Physical Review Letters*, **67** (1991) 652.
- [10] R.D. Beck, P. Maroni, D.C. Papageorgopoulos, T.T. Dang, M.P. Schmid, T.R. Rizzo, *Science*, **302** (2003) 98-100.
- [11] L.B.F. Juurlink, P.R. McCabe, R.R. Smith, C.L. DiCologero, A.L. Utz, *Physical Review Letters*, **83** (1999) 868.
- [12] L.B.F. Juurlink, R.R. Smith, D.R. Killelea, A.L. Utz, *Physical Review Letters*, **94** (2005) 208303.
- [13] P. Maroni, D.C. Papageorgopoulos, M. Sacchi, T.T. Dang, R.D. Beck, T.R. Rizzo, *Physical Review Letters*, **94** (2005) 246104.
- [14] R.R. Smith, D.R. Killelea, D.F. DelSesto, A.L. Utz, *Science*, **304** (2004) 992-995.
- [15] A.W. Kleyn, *Progress in Surface Science*, **54** (1997) 407-420.
- [16] E.W. Kuipers, M.G. Tenner, A.W. Kleyn, S. Stolte, *Nature*, **334** (1988) 420-422.
- [17] E.W. Kuipers, M.G. Tenner, A.W. Kleyn, S. Stolte, *Physical Review Letters*, **62** (1989) 2152.
- [18] L. Vattuone, L. Savio, F. Pirani, D. Cappelletti, M. Okada, M. Rocca, *Progress in Surface Science*, **85** (2010) 92-160.
- [19] B.L. Yoder, R. Bisson, R.D. Beck, *Science*, **329** (2010) 553-556.
- [20] D.B. Kokh, R.J. Buenker, J.L. Whitten, *Surface Science*, **600** (2006) 5104-5113.
- [21] M. Alducin, H.F. Busnengo, R. Díez Muiño, *The Journal of Chemical Physics*, **129** (2008) 224702.
- [22] J. Behler, B. Delley, S. Lorenz, K. Reuter, M. Scheffler, *Physical Review Letters*, **94** (2005) 036104.
- [23] J. Behler, K. Reuter, M. Scheffler, *Physical Review B*, **77** (2008) 115421.
- [24] C. Carbogno, J. Behler, A. Groß, K. Reuter, *Physical Review Letters*, **101** (2008) 096104.

- [25] K. Kato, T. Uda, K. Terakura, *Physical Review Letters*, **80** (1998) 2000.
- [26] H. Hou, Y. Huang, S.J. Gulding, C.T. Rettner, D.J. Auerbach, A.M. Wodtke, *Science*, **284** (1999) 1647-1650.
- [27] Y. Huang, C.T. Rettner, D.J. Auerbach, A.M. Wodtke, *Science*, **290** (2000) 111-114.
- [28] S. Roy, N. Shenvi, J.C. Tully, *The Journal of Physical Chemistry C*, **113** (2009) 16311-16320.
- [29] N. Shenvi, S. Roy, J.C. Tully, *Science*, **326** (2009) 829-832.
- [30] J.D. White, J. Chen, D. Matsiev, D.J. Auerbach, A.M. Wodtke, *Nature*, **433** (2005) 503-505.
- [31] A.M. Wodtke, J.C. Tully, D.J. Auerbach, *International Reviews in Physical Chemistry*, **23** (2004) 513 - 539.
- [32] A. Amirav, M.J. Cardillo, *Physical Review Letters*, **57** (1986) 2299.
- [33] B. Gergen, H. Nienhaus, W.H. Weinberg, E.W. McFarland, *Science*, **294** (2001) 2521-2523.
- [34] H. Nienhaus, *Surface Science Reports*, **45** (2002) 1-78.
- [35] H. Nienhaus, H.S. Bergh, B. Gergen, A. Majumdar, W.H. Weinberg, E.W. McFarland, *Physical Review Letters*, **82** (1999) 446.
- [36] I. Langmuir, *Transactions of the Faraday Society*, **17** (1922) 621-654.
- [37] C.N. Hinshelwood, *Ann. Res. London Chem. Soc.*, **27** (1930) 11.
- [38] D.D. Eley, E.K. Rideal, *Nature (London)*, **146** (1940) 40.
- [39] D.D. Eley, *Proceedings of the Royal Society of London. Series A. Mathematical and Physical Sciences*, **178** (1941) 452-464.
- [40] J. Harris, B. Kasemo, *Surface Science*, **105** (1981) L281-L287.
- [41] S.T. Ceyer, *Science*, **249** (1990) 133-139.
- [42] M. Asscher, Y. Zeiri, *The Journal of Physical Chemistry B*, **107** (2003) 6903-6919.
- [43] L. Diekhöner, H. Mortensen, C. Akerlund, A. Baurichter, A.C. Luntz, *The Journal of Chemical Physics*, **114** (2001) 4215-4220.
- [44] C.T. Rettner, D.J. Auerbach, *The Journal of Chemical Physics*, **105** (1996) 8842-8848.
- [45] C.T. Rettner, J. Lee, *The Journal of Chemical Physics*, **101** (1994) 10185-10188.
- [46] B. Riedmüller, F. Giskes, D.G. van Loon, P. Lassing, A.W. Kleyn, *Measurement Science & Technology*, **13** (2002) 141-149.
- [47] A. Raukema, *Dynamics of Chemisorption*, in, University of Amsterdam, 1995.
- [48] F. Gou, M.A. Gleeson, J. Vilette, A.W. Kleyn, *Vacuum*, **81** (2006) 196-201.
- [49] R.P. Dahiya, M.J. de Graaf, R.J. Severens, H. Swelsen, M.C.M. van de Sanden, D.C. Schram, *Physics of Plasmas*, **1** (1994) 2086-2095.
- [50] S. Mazouffre, I. Bakker, P. Vankan, R. Engeln, D.C. Schram, *Plasma Sources Science and Technology*, **11** (2002) 439.
- [51] M.C.M. van de Sanden, G.M. Janssen, J.M. de Regt, D.C. Schram, J.A.M. van der Mullen, B. van der Sijde, *Review of Scientific Instruments*, **63** (1992) 3369-3377.
- [52] M.C.M. van de Sanden, R.J. Severens, J.W.A.M. Gielen, R.M.J. Paffen, D.C. Schram, *Plasma Sources Science & Technology*, **5** (1996) 268-274.
- [53] H.G. Jenniskens, A. Bot, P.W.F. Dorlandt, W. van Essenber, E. de Haas, A.W. Kleyn, *Measurement Science and Technology*, **8** (1997) 1313.
- [54] G. Scoles, *Atomic and Molecular Beam Methods*, in, Oxford University Press, New York, 1988.
- [55] K. Kern, R. David, G. Comsa, *The Journal of Chemical Physics*, **82** (1985) 5673-5676.

- [56] J.E. Pollard, D.J. Trevor, Y.T. Lee, D.A. Shirley, *The Journal of Chemical Physics*, **77** (1982) 4818-4825.
- [57] D.A. King, M.G. Wells, *Surface Science*, **29** (1972) 454-482.
- [58] D.A. King, M.G. Wells, *Proceedings of the Royal Society London A*, **339** (1974) 245-269.
- [59] R.N. Carter, M.J. Murphy, A. Hodgson, *Surface Science*, **387** (1997) 102-111.
- [60] I.M.N. Groot, J.C. Juanes-Marcos, C. Diaz, M.F. Somers, R.A. Olsen, G.-J. Kroes, *Physical Chemistry Chemical Physics*, **12** (2010) 1331-1340.
- [61] I.M.N. Groot, J.C. Juanes-Marcos, R.A. Olsen, G.-J. Kroes, *The Journal of Chemical Physics*, **132** (2010) 144704.
- [62] R. Díez Muiño, L. Martin-Gondre, G.A. Bocan, M. Alducin, I. Juaristi, Energy dissipation channels in hyperthermal atomic and molecular scattering off metal surfaces, in: *European Conference on Surface Science 27*, Groningen, the Netherlands, 2010.

