

Cover Page



Universiteit Leiden



The handle <http://hdl.handle.net/1887/20909> holds various files of this Leiden University dissertation.

Author: Bruggink, Cornelis

Title: Characterization of oligosaccharides with capillary high performance anion exchange chromatography hyphenated to pulsed amperometric detection and ion trap mass spectrometry

Issue Date: 2013-05-29

3

OLIGOSACCHARIDE ANALYSIS
BY CAPILLARY-SCALE HIGH-pH ANION-
EXCHANGE CHROMATOGRAPHY WITH
ON-LINE ION-TRAP MASS SPECTROMETRY

3.1 ABSTRACT

A capillary-scale high-pH anion-exchange chromatography (HPAEC) system for the analysis of carbohydrates was developed, in combination with two parallel on-line detection methods of sub-picomolar sensitivity: (1) pulsed amperometric detection (PAD); (2) capillary-scale desalting followed by electrospray ion-trap (IT) mass spectrometry (MS). The capillary chromatographic system combined the superb selectivity of HPAEC that allows routine separation of isomeric oligosaccharides with the information on monosaccharide sequence and linkage positions obtained by MS/MS fragmentation using the IT-MS. The applicability of the system in biomedical research was demonstrated by its use for the analysis of a urine sample of a G_{M1} -gangliosidosis patient. Isomeric glycans in the sample could be resolved by HPAEC and assigned on the basis of the monosaccharide linkage information revealed by on-line IT-MS/MS.

Cees Bruggink^{a,c}, Manfred Wuhrer^a, Carolien A.M. Koeleman^a, Victor Barreto^b, Yan Liu^b,
Chris Pohl^b, Arnd Ingendoh^d, Cornelis H. Hokke^a, André M. Deelder^a

^a Biomolecular Mass Spectrometry Unit, Department of Parasitology, Center for Infectious Diseases, Leiden University Medical Center, P.O. Box 9600, 2300 RC Leiden, The Netherlands

^b Dionex Corporation, 1228 Titan Way, Sunnyvale, CA 94088-3603, USA

^c Dionex BV, Lange Bunder 5, 4854 MB Bavel, The Netherlands

^d Bruker Daltonik GmbH, Fahrenheitstr. 4, 28359 Bremen, Germany

Journal of Chromatography B (2005) 829; 136–143.

3.2 INTRODUCTION

Within the panel of analytical techniques available for the characterization of oligosaccharides, chromatographic methods play a central role [1,2]. While reverse-phase HPLC of oligosaccharides requires derivatization [2,3], other stationary phases such as normal-phase and porous graphitized carbon allow the separation of both derivatized and native oligosaccharides [2-4]. Photometric detection of native carbohydrates is insensitive because they lack a natural chromophore or fluorophore, and therefore derivatization at the reducing end is usually required to allow detection in the sub-picamol range by fluorescence detection [5]. An alternative, sensitive and widely used chromatographic system for the separation and analysis of underivatized carbohydrates is high-pH anion-exchange chromatography with pulsed amperometric detection (HPAEC-PAD) [6,7]. This chromatographic system is based on the fact that carbohydrates are weak acids [8], which form anions in an eluent of high pH. In addition, the presence of aldehydes, ketones and multiple hydroxyl groups in carbohydrates makes them relatively attractive electrochemical analytes and pulsed amperometry therefore allows the detection of oligosaccharides at low picamol levels [9] when using a 4 mm I.D. analytical column.

Both on-line-coupling to mass spectrometry and downscaling of the column dimensions to the capillary- or nano-scale are important for the development of glycan analysis technology that is compatible with current standards in biomedical research. These requirements have already been met for the graphitized carbon stationary phase [3,4,10], normal phase (NPLC) [11,12] and reversed phase liquid chromatography (RPLC) [3,13]. In the case of HPAEC-PAD, however, oligosaccharide separation with on-line desalting and on-line mass spectrometry has so far only been demonstrated at the narrow bore (2 mm column I.D.) [14-16] and at the analytical scale (4 mm column I.D.) [17].

This study describes the implementation of a prototype capillary bore (0.381 mm I.D.) column for HPAEC with on-line pulsed amperometric detection and on-line electrospray ion-trap mass spectrometry (IT-MS). MS coupling was made possible with an experimental on-line capillary-scale desalter. The system exhibits sub-picamol sensitivity, both in amperometric and in mass spectrometric detection, and was found to be particularly useful for the characterization of complex biological samples due to its high chromatographic resolution combined with the MS/MS capabilities of the ion-trap mass spectrometer.

3.3 EXPERIMENTAL

3.3.1 Chemicals

Analytical reagent grade sodium hydroxide (50%, w/w), sodium acetate, sulphuric acid and sodium chloride were obtained from J.T. Baker (Deventer, The Netherlands). Acetonitril was from Biosolve (Valkenswaard, The Netherlands). All solutions were prepared with water from a Milli-Q synthesis system from Millipore BV (Amsterdam, The Netherlands). The asialo diantennary glycan was a gift from Dr. D.H. van den Eijnden (Free University, Amsterdam). Chicory inulin was obtained from Warcoing Research (Warcoing, Belgium).

3.3.2 Chromatographic system

A schematic drawing of the complete instrumental set-up is shown in Fig. 3-1. The BioLC system from Dionex (Sunnyvale, CA, USA) consisted of a microbore GP40 gradient pump, a Famos micro autosampler with a full PEEK-injector and a 0.41 μl loop, and an ED40 electrochemical detector, all controlled by Chromeleon software (Dionex).

Coupled to the system was an Esquire 3000 ion-trap mass spectrometer from Bruker Daltonik (Bremen, Germany), equipped with an electrospray ionization source. A microbore AGP-1 from Dionex was used as an auxiliary pump (see Section 3.3.3.2).

3.3.2.1 Flow splitter for providing the eluent

To accomplish a flow rate of 10 $\mu\text{l}/\text{min}$, a homemade flow splitter (split ratio 56:1) constructed entirely from PEEK was inserted between the gradient pump and the autosampler. The eluent flow was split up via a TEE (P-715; Scivex Upchurch Scientific, Oak Harbor, WA, USA). The analytical column was connected to the TEE by 1256 $\text{cm} \times 0.075 \text{ mm}$ I.D. tubing. To the other exit of the TEE 1316 $\text{cm} \times 0.125 \text{ mm}$ I.D. and in addition 894 $\text{cm} \times 0.750 \text{ mm}$ I.D. tubing was connected.

To determine flow rates at various places in the capillary system a 25 μl syringe without plunger was coupled to the appropriate exit and the filling time was measured with a stopwatch.

3.3.2.2 Analytical column

A prototype capillary column (250 $\text{mm} \times 0.381 \text{ mm}$ I.D.) packed with CarboPac PA200 resin was manufactured by Dionex. The stationary phase is a 5.5 μm diameter ethylvinylbenzene/divinylbenzene substrate (55% cross-linking), agglomerated with 34 nm MicroBead™ 6% cross-linked quaternary amine functionalized latex.

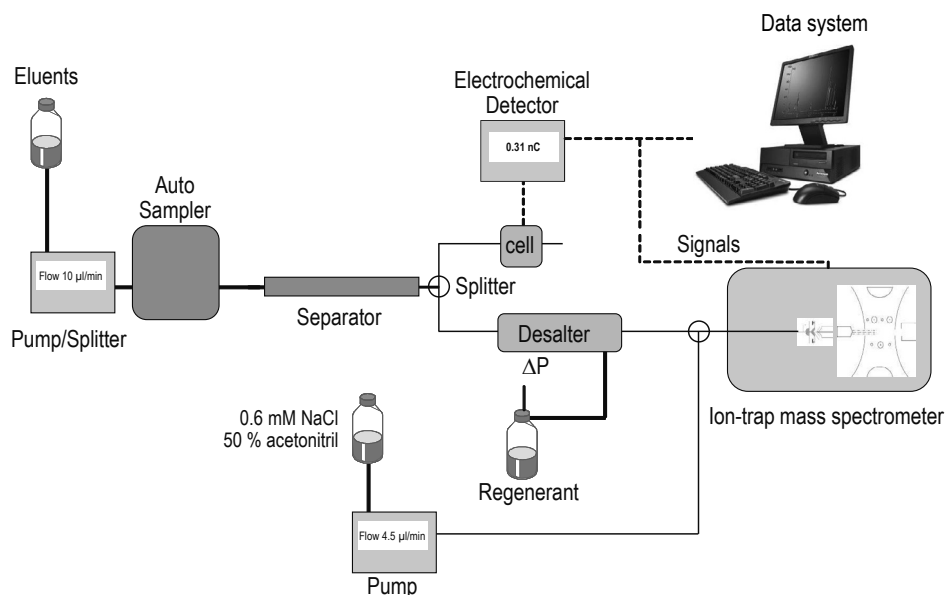

Figure 3-1. Schematic representation of the experimental set-up of capillary HPAEC with electrochemical as well as on-line-mass spectrometric detection.

3.3.2.3 Flow splitter for detection

To avoid unacceptable loss of resolution, the detectors were coupled to the outlet of the analytical column in parallel. The desalter was connected to a PEEK TEE (P-715 from Scivex Upchurch Scientific Division) and put in-line with the mass spectrometer with a total of 150 cm \times 0.075 mm I.D. PEEK tubing. The electrochemical cell and 350 cm \times 0.075 mm I.D. PEEK tubing were connected to the other outlet of the TEE. This resulted in a split ratio of 11 to 5 for MS to PAD. The total backpressure was 210 kPa, which was found to be sufficient to minimize system flow fluctuations.

3.3.2.4 Desalter

To convert the eluent into an electrospray ionization (ESI)-compatible solution, a capillary in-line desalter was prepared. The desalter consisted of a Nafion cation-exchange capillary (15 cm \times 0.102 mm I.D. \times 0.254 mm O.D.) housed in a PEEK column (250 cm \times 4 mm I.D.) with inlet and outlet liquid connecting ports. Provisions were made so that there were separate fluid connections to the cation exchange capillary tubing in the PEEK column. The cation exchange capillary was maintained predominantly in the hydronium form by flowing dilute sulfuric acid through the PEEK column so that the capillary was fully immersed in the solution of sulfuric acid. Using the capillary desalter, neutral and anionic compounds pass to the mass spectrometer, and the eluent is converted into water and acetic acid.

3.3.3 Detection

3.3.3.1 Electrochemical detection

The ED40 detector delivered to the electrochemical cell the following waveform: $E_1 = 0.1\text{V}$ ($t_d = 0.00\text{--}0.20\text{ s}$, $t_1 = 0.20\text{--}0.40\text{ s}$), $E_2 = -2.0\text{V}$ ($t_2 = 0.41\text{--}0.42\text{ s}$), $E_3 = 0.6\text{V}$ ($t_3 = 0.43\text{ s}$), $E_4 = -0.1\text{V}$ ($t_4 = 0.44\text{--}0.50\text{ s}$) versus an Ag/AgCl reference electrode [18]. A gold work electrode and a 25 μm gasket were installed. The inlet stainless steel tube of the cell was removed to minimize void volume. The electrochemical cell was placed in the low-pressure splitter outlet as described in Section 3.3.2.3.

3.3.3.2 Mass spectrometry

For efficient ionization of the eluted carbohydrates and in order to get a stable electrospray, a make-up solution (0.6 mM NaCl in 50% acetonitrile) was pumped into the eluent flow via a MicroTEE (P-775 Scivex). To obtain a flow rate of 4.6 $\mu\text{l}/\text{min}$ for the make-up solution, the auxiliary pump was equipped with a homemade low-pressure PEEK splitter with a split ratio of 1:46.5. The mixture was directed to the electrospray ionization (ESI) interface of an Esquire 3000 ion-trap mass spectrometer from Bruker Daltonik. Neutral carbohydrates were detected with MS in the positive ion mode as sodium adducts. Analyses were routinely performed in the automatic MS/MS mode. The mass spectrometer was operated at the following conditions: dry temperature 325 $^\circ\text{C}$, nebulizer 103 kPa, dry gas 7 l/min, capillary -3500V and target mass m/z 850.

3.3.4 Separation conditions

The GP40 pumped with a flow rate of 10 $\mu\text{l}/\text{min}$ and was provided with the following eluents: eluent A, water; eluent B, 500mM NaOH; eluent C, 500mM sodium acetate. All separations were performed at room temperature. The asialo diantennary *N*-glycan was chromatographed under isocratic conditions (70% A+ 30% B). The ternary gradient for fructan oligosaccharides was as follows: The column was first washed with 76% A+ 24% B (-20 to -14 min; isocratic) in

order to convert the column into the hydroxide form, followed by an equilibration with 88% A+ 12% B (-14 to 0 min; isocratic). Elution was achieved with a linear acetate gradient to 25.5% A+ 12% B+ 62.5% C (0–55 min). For analysis of urinary oligosaccharides from patients with G_{M1} -gangliosidosis the gradient was as follows: 76% A+ 24% B (-20 to -14 min; isocratic); 88% A+ 12% B (-14 to 0 min; isocratic); linear hydroxide gradient to 60% A+ 40% B (0–9.1 min); 60% A+ 40% B (9.1–12.5 min; isocratic); linear gradient to 85.2% A+ 12% B+ 2.8% C (12.5–21.6 min); linear acetate gradient to 60.5%A+ 12% B+ 27.5% C (21.6–104 min). The samples were injected at 0 min.

3.3.5 Preparation of urine samples

Oligosaccharides of urine samples were isolated with graphitized carbon solid phase extraction, according the method described by Packer et al. [19]. Two hundred μ l of urine was diluted with 1800 μ l water and loaded on a Carbograph SPE cartridge (300 mg; Alltech Associates Inc., Deerfield, IL, USA). The cartridge was washed with water (6 ml) and the neutral oligosaccharides were subsequently eluted with 3ml 25% acetonitrile. The eluate was concentrated under a stream of nitrogen at room temperature until the volume was decreased to 50%. The remaining solution was lyophilized and reconstituted in 200 μ l water.

3.4 RESULTS

3.4.1 Characterisation of the desalter

In order to determine the desalting capacity of the prototype on-line capillary desalter, various concentrations of NaOH were pumped through at a flowrate of 10 μ l/min over a time range of at least 60 min, with a regenerant flow of 825 μ l/min. The regenerant concentration was kept constant at 12.5 mM sulphuric acid. Higher concentrations of regenerant were avoided in order to prevent the breakthrough of the sulphate ions according to the Donnan-exclusion [20,21]. The conductivity of the effluent was continuously monitored and every 10 min the pH was checked with universal pH-paper. It was determined that the desalting capacity of the capillary desalter is 225 mM NaOH for the tested eluent flow rate of 10 μ l/min. The resulting effluent conductivity was 54 μ S/cm, the pH was 7 and was stable for at least 60 min. To determine to which extent the desalter contributed to peak broadening, the system was tested with a 0.41 μ l injection of an inulin solution of 300 μ g/ml. Inulin contains two linear homologous series of fructan oligosaccharides (FOS) [22,23]. The most abundant series terminates in sucrose, the other in fructopyranosyl. FOS from inulin were separated with a sodium acetate gradient in sodium hydroxide with the electrochemical cell directly installed after the capillary column (Fig. 3-2A).

Alternatively, the desalter in the sodium form was installed between the column and the electrochemical cell (Fig. 3-2B). For the registered peak pair 1, which eluted in the isocratic part of the separation, resolution was 0.94 and 0.70 without and with the desalter, respectively. For peak pair 2, which eluted in the gradient part of the separation, the resulting resolutions were 8.38 versus 5.47. The retention time shift caused by the desalter was 8 s and corresponded to an internal volume of 1.35 μ l.

3.4.2 Gradient performance and detection of fructan oligosaccharides

To test the gradient performance of the instrumental set-up, a solution of 1 mg/ml inulin was chromatographed. The estimated gradient delay time to the electrochemical detector was 11.2

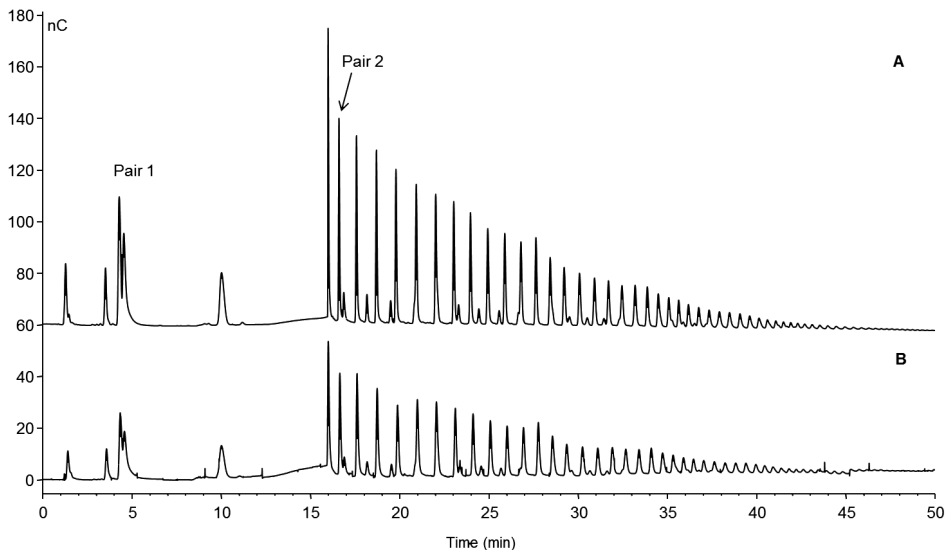

Figure 3-2. Capillary HPAEC-PAD separation of fructan oligosaccharides. The chromatographic behaviour of fructan oligosaccharides from 123 ng native chicory inulin was compared with and without on-line-desalting. (A) The electrochemical cell was directly connected to the column. (B) The capillary desalter was positioned between the column and the electrochemical cell.

min. Extracted ion chromatograms (EIC) of FOS up to DP13 (degree of polymerization) are shown in Fig. 3-3. At higher masses doubly charged sodium adducts were observed. By use of extracted ion chromatograms co-eluting variants could be discriminated such as two species eluting at approximately 20 min, namely DP5 (m/z 851.3) and DP7 (m/z 1175.7). In each EIC corresponding to a certain DP, two fully separated peaks were present, representing sodium adducts of the two isobaric variants, which demonstrated the separation potential of the HPAEC system. From the extracted ion chromatograms it turned out that the homologous series terminating in fructopyranose exhibited more retention than the series terminating in glucopyranose.

As analyses were performed in the automatic MS/MS mode, fragmentation spectra were obtained for most of the FOS. Fig. 3-4B and C shows MS/MS spectra of the two isobaric DP5 variants, which exhibited similar fragmentation patterns, yet varied in the relative intensities of the fragment ions. The MS/MS spectra show mainly cleavages of glycosidic linkages and ions representing a loss of 90 Da (m/z 437.2 and 275.2). This loss of 90 Da can arise from ring fragmentation as indicated in Fig. 3-4B.

3.4.3 Signal response of the detectors

Signal response of the system has been investigated for both detectors under isocratic conditions with the asialo *N*-linked diantennary glycan. Five concentrations in the range of 0.16–100 pmol were tested in three fold. The IPAD signal was linear up to 20 pmol, while the MS signal was linear over the whole range investigated (regression coefficient >0.999 for IPAD and MS). A sub-picomolar detection limit was achieved, as demonstrated in Fig. 3-5. From the total amount of 160 fmol diantennary oligosaccharide injected on column, about 50 fmol was directed to the electrochemical detector and 110 fmol to the mass spectrometer.

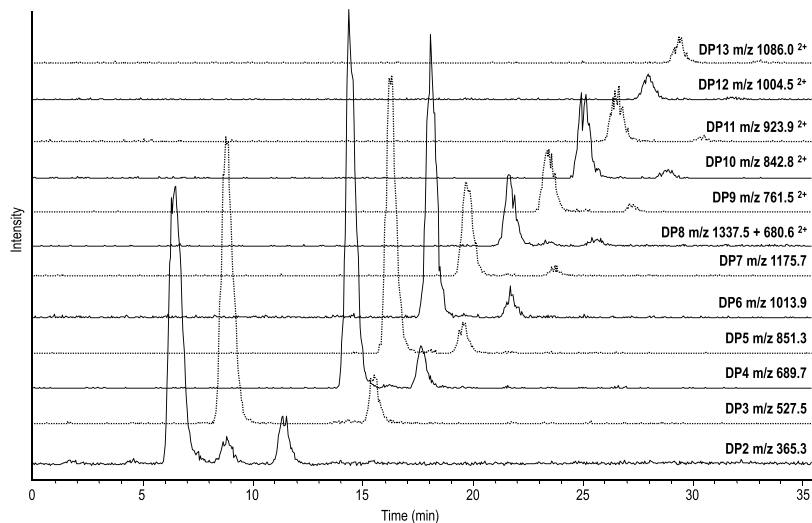

Figure 3-3. Capillary HPAEC-on-line-MS analysis of fructan oligosaccharides. Fructan oligosaccharides from 410 ng native chicory inulin were analyzed by capillary HPAEC with on-line-desalting and electrospray-MS detection. Extracted ion chromatograms are given for fructan oligosaccharides of various degrees of polymerization (DP) which were detected as sodium adducts.

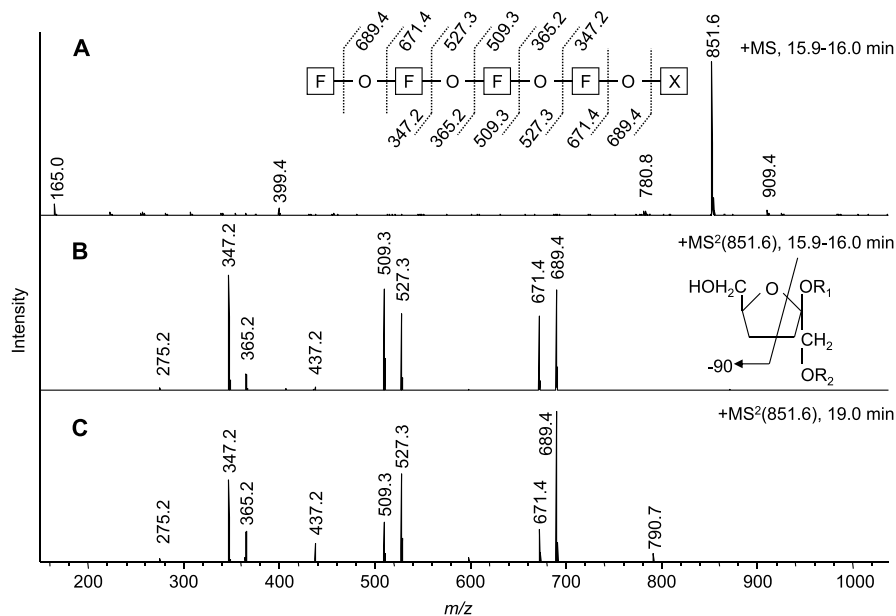

Figure 3-4. Mass spectra of the two isobaric sodium adducts of DP5 fructans. Part (A) shows the MS spectrum of $[GF_4 + Na]^+$; parts (B) and (C) are the MS^2 spectra with m/z 851.6 as precursor ion, where (B) represents GF_4 and (C) F_5 . In the fragmentation scheme, F stands for fructofuranosyl and X is glucopyranosyl or fructopyranosyl, R_1 and R_2 stand for the rest part of the oligosaccharide chain and R_2 can also be a H.

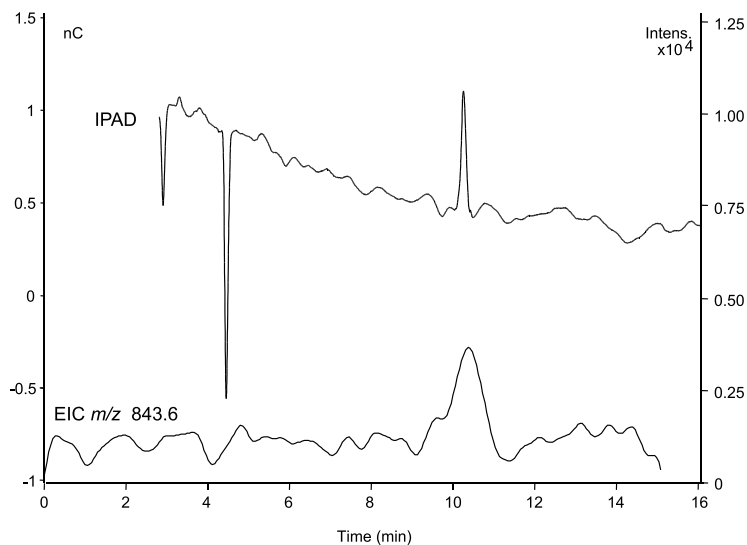

Figure 3-5. Analysis of an 160 fmol aliquot of an asialo diantennary glycan by combined capillary HPAEC-PAD/online-MS detection. The chromatogram obtained from the electrochemical detector (IPAD) is corrected for the 2.68 min retention difference with the online-MS detection (EIC) of the double-sodiated species.

3.4.4 Urine sample of a G_{M1} -gangliosidosis patient

As a relevant example of a clinical application, a urine sample of a G_{M1} -gangliosidosis patient was analyzed with the system. The resulting chromatogram is given in Fig. 3-6. Oligosaccharides from urine were extracted using a carbon cartridge, and the equivalent of 400 nl urine was injected on the column. The electrochemical detector gave a complex peak pattern (not shown). On-line mass spectrometric detection revealed the presence of a dihexose (most likely lactose) as well as complex oligosaccharides of composition $H_{3-7}N_{1-5}$ (H: hexose; N: *N*-acetylhexosamine), which were detected in monosodiated form (H_3N_2 and H_3N) or disodiated form (H_5N_3 , H_6N_4 and H_7N_5 ; Fig. 3-6). In accordance with literature data [24,25], we interpreted H_3N_2 , H_5N_3 , H_6N_4 and H_7N_5 as monoantennary, diantennary, triantennary and tetraantennary endo- β -*N*-acetylglucosaminidase cleaved products of complex type *N*-glycan structures, respectively.

This assignment was corroborated by the obtained MS/MS data. Oligosaccharides of composition H_3N were interpreted as glycolipid degradation products and exhibited a reducing end hexose–hexose moiety, which is in accordance with the lactosyl core structure of mammalian-type-glycolipids. Of the complex LC–MS/MS data set covering all these species, the data for H_3N_2 species will be presented in detail, as capillary HPAEC in conjunction with on-line desalting/mass spectrometry succeeded to completely resolve two isobaric structures of this composition (Fig. 3-6). Both structures A (elution at 8.9 min; Fig. 3-6) and B (elution at 12.9 min) were detected in sodiated form with a monoisotopic mass of 933.5 Da. The obtained MS/MS data of the two isomeric species were acquired in the automatic mode and are assigned according to the nomenclature of Domon and Costello [26] (Fig. 3-7A and B). Based on linkage-specific fragmentation, these data allowed the assignment of the two isomers to published structures of

urine oligosaccharides in G_{M1} -gangliosidosis [24,25]: Both oligosaccharides seemed to contain a *N*-acetylhexosamine at the reducing end, which displayed specific ring fragmentations ($^{0,2}A$ at m/z 832 and $^{2,4}A$ at m/z 772). These fragments, together with the lack of a $^{0,3}A$ ring cleavage (no signal at m/z 802), are characteristic for a 4-substituted *N*-acetylhexosamine, according to the ring fragmentation rules established for sodiated oligosaccharides [27-29]. The observed series of B-ions results in a monosaccharide sequence of H-N-H-H-N for both isomers (Fig. 3-7A and B). For compound A, the observed ring fragmentations ($^{0,2}A$ at m/z 670, $^{0,3}A$ at m/z 640 and $^{0,4}A$ at m/z 610) of the hexose next to the reducing-end *N*-acetylhexosamine are typical for a substituent in the 6 position (Fig. 3-7A) [27-29]. Based on this information, compound A was concluded to be the G_{M1} -gangliosidosis urinary oligosaccharide Gal(β 1-4)GlcNAc((β 1-2)Man(α 1-6)Man(β 1-4)GlcNAc (Fig. 3-7A), which has been characterized before [24,25].

A lack of these ring fragments is typical for a substituent in the 3 position [27-29]. We conclude, therefore, compound B to be the isomer Gal(β 1-4)GlcNAc((β 1-2)Man(α 1-3)Man(β 1-4)GlcNAc (Fig. 3-7B), which has likewise been found previously in G_{M1} -gangliosidosis urine [24,25].

3.5 DISCUSSION

We here describe a capillary-scale HPAEC system for the separation of oligosaccharides with both electrochemical and on-line mass spectrometric detection. With respect to electrochemical

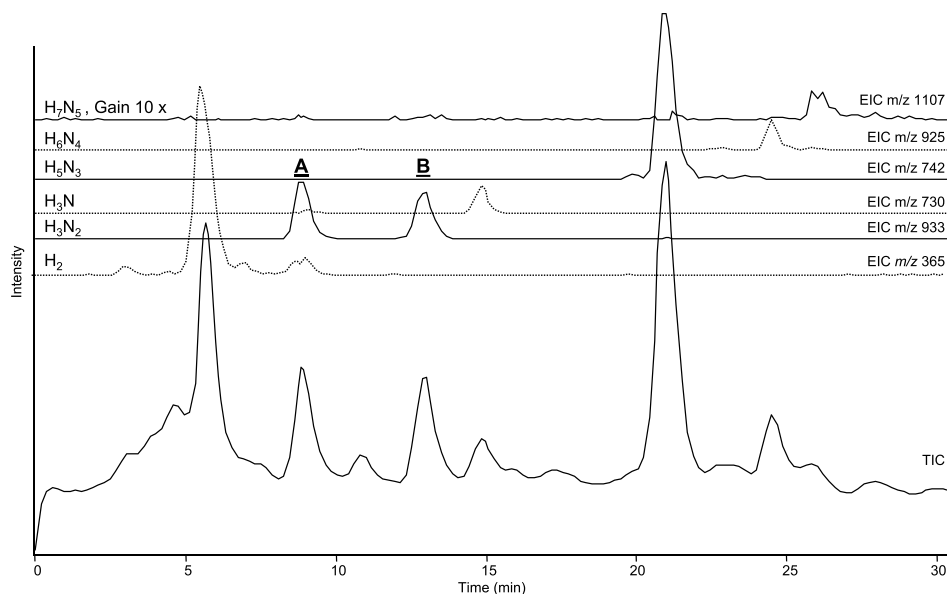

Figure 3-6. HPAEC-on-line-MS of oligosaccharides from the urine sample of a G_{M1} -gangliosidosis patient. TIC is the total ion chromatogram. The extracted ion chromatograms (EIC) represent the major pseudomolecular ions registered. Several of the EIC show the separation of isobaric structures. Fragmentation analysis of the well-separated H_3N_2 species A and B is shown in Fig. 3-7. H, Hexose; N, *N*-acetylhexosamine.

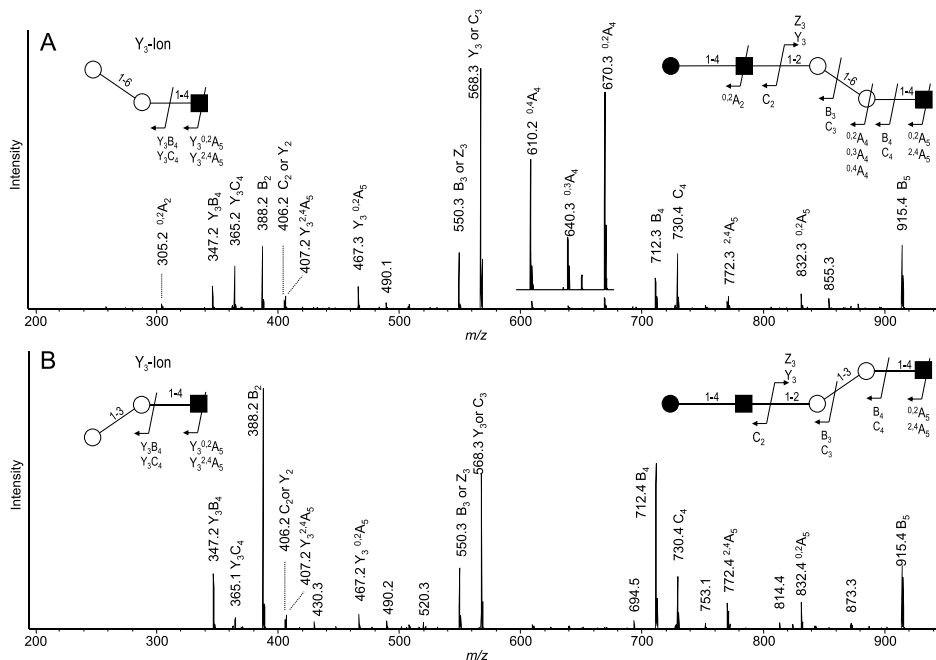

Figure 3-7. Fragment ion analysis of H₃N₂ species. H₃N₂ species A and B, as indicated in Fig. 3-6, were subjected to MS² analysis in their sodiated form (*m/z* 933.5; A and B, respectively). The observed fragment ions are schematically interpreted according to the nomenclature of Domon and Costello [26]. Empty circle, mannose; filled circle, galactose; filled square, *N*-acetylglucosamine.

detection, the system displayed the usual excellent performance of HPAEC for the separation of oligosaccharides [6,7]. The downscaling from a narrow bore to a capillary-scale system involved reduction of the dead volume of a standard electrochemical cell by the surprisingly straightforward exchange of the metal inlet tube for a PEEK tube with a internal diameter of 75 μm . Regarding mass spectrometric detection, an on-line desalting step was incorporated in the system in order to allow electrospray ionization-MS at high sensitivity. The degree of peak broadening generated by the desalter was found to be insignificant, and the superb chromatographic performance of HPAEC resulted in the resolution of isomeric structures. The MS detector is particularly useful for the analysis of complex mixtures as for example the fructan oligosaccharides, where it allows the differentiation between co-eluting carbohydrates.

While the desalter was found to work efficiently with concentrations of sodium ions up to 225 mM for longer periods, the system tolerated significantly higher concentrations of sodium ions for short periods when run in the gradient mode. During the separation of fructan oligo- and polysaccharides of inulin the eluent concentration raised up to 372.5 mM sodium, while detection by IT-MS remained excellent, indicating that desalting was still sufficient.

In a previous study, HPAEC was performed at the microbore scale (column of 2 mm I.D.), allowing a lower detection limit of 17 pmol for maltoheptaose (DP7 of (α 1-4)-glucose oligomer) [30]. When corrected for the different column diameters, this would result in a theoretical

sensitivity of 615 fmol at a 380 μm I.D. capillary system ($17 \text{ pmol} \times (380 \mu\text{m}/2000 \mu\text{m})^2$). The capillary-scale system used in this study (380 μm I.D.) actually exhibited even higher sensitivity, as demonstrated with the mass spectrometric detection of 110 fmol of a diantennary glycan (3.3). When compared to the 2 mm I.D. system [30], mass spectrometric sensitivity increased by a factor of 100. For amperometric detection, the detection limit was found to be around 50 fmol, which means a sensitivity gain by a factor of 50 compared to the results with a 4mm I.D. column published by Rocklin et al. [9,18].

As the Esquire 3000 IT-MS used in the current study was formerly used for nano-scale (75 μm I.D.) normal phase-LC/MS of oligosaccharides, sensitivities of the systems can directly be compared: nano-scale normal phase-LC-MS with a nanoelectrospray source exhibited sensitivities of approximately 1 fmol for both native [11] and derivatized oligosaccharides [12]. When correcting for the differences in column I.D., this would yield a theoretical sensitivity of 25 fmol at the 380 μm I.D. scale.

HPAEC with pulsed amperometric detection has been used for diagnostic purposes of glycoprotein degradation disorders [31]. From the chromatograms generated by HPAEC it was not possible however to identify each observed component, such in strong contrast to the system presented here which includes on-line MS detection to provided mass and fragmentation data. We have evaluated our system using G_{M1} -gangliosidosis urinary oligosaccharides. The total ion chromatogram of Fig. 3-6 shows the most abundant oligosaccharides and their masses. Two separated isomeric oligosaccharides could be assigned based on mass and fragmentation patterns to urinary oligosaccharide structures, which are described in the literature on G_{M1} -gangliosidosis [24,25]. Moreover, polymeric carbohydrates with the α 1-6 linkage type are known to elute faster from an anion-exchange resin than isomers with a α 1-3 linkage [7], which is in line with the obtained results.

Based on the presented data, we would like to conclude that the system, which combines the high separation power of HPAEC at a thus far unattained capillary-scale with the oligosaccharide sequence and linkage information provided by on-line ion-trap MS/MS, is a powerful new tool for (clinical) glycomics studies.

REFERENCES

1. Honda S (1984) High-performance liquid chromatography of mono- and oligosaccharides. *Anal Biochem* **140**, 1-47.
2. Anumula KR (2000) High-sensitivity and high-resolution methods for glycoprotein analysis. *Anal Biochem* **283**, 17-26.
3. Wuhrer M, Deelder AM, & Hokke CH (2005) Protein glycosylation analysis by liquid chromatography-mass spectrometry. *J Chromatogr B Biomed Sci App* **825**, 124-133.
4. Barroso B, Dijkstra R, Geerts M, Lagerwerf F, van Veelen P, & de Ru A (2002) On-line high-performance liquid chromatography/mass spectrometric characterization of native oligosaccharides from glycoproteins. *Rapid Commun Mass Spectrom* **16**, 1320-1329.
5. Royle L, Mattu TS, Hart E, Langridge JI, Merry AH, Murphy N, Harvey DJ, Dwek RA, & Rudd PM (2002) An analytical and structural database provides a strategy for sequencing O-glycans from microgram quantities of glycoproteins. *Anal Biochem* **304**, 70-90.
6. Cataldi TR, Campa C, & De Benedetto GE (2000) Carbohydrate analysis by high-performance anion-exchange chromatography with pulsed amperometric detection: the potential is still growing. *Fredericus J Anal Chem* **368**, 739-758.

7. Lee YC (1990) High-performance anion-exchange chromatography for carbohydrate analysis. *Anal Biochem* **189**, 151-162.
8. Rendleman JA (1973) Ionization of Carbohydrates in the Presence of Metal Hydroxides and Oxides. In *Carbohydrates in Solution* pp. 51. Washington DC.
9. Rocklin RD, Tullsen TR, & Marucco MG (1994) Maximizing signal-to-noise ratio in direct current and pulsed amperometric detection. *J Chromatogr A* **671**, 109-114.
10. Kawasaki N, Itoh S, Ohta M, & Hayakawa T (2003) Microanalysis of N-linked oligosaccharides in a glycoprotein by capillary liquid chromatography/mass spectrometry and liquid chromatography/tandem mass spectrometry. *Anal Biochem* **316**, 15-22.
11. Wuhrer M, Koelman CA, Deelder AM, & Hokke CH (2004) Normal-phase nanoscale liquid chromatography-mass spectrometry of underivatized oligosaccharides at low-femtomole sensitivity. *Anal Chem* **76**, 833-838.
12. Wuhrer M, Koelman CA, Hokke CH, & Deelder AM (2004) Nano-scale liquid chromatography-mass spectrometry of 2-aminobenzamide-labeled oligosaccharides at low femtomole sensitivity. *Int J Mass Spectrom* **232**, 51-57.
13. Gennaro LA, Harvey DJ, & Vouros P (2003) Reversed-phase ion-pairing liquid chromatography/ion trap mass spectrometry for the analysis of negatively charged, derivatized glycans. *Rapid Commun Mass Spectrom* **17**, 1528-1534.
14. Torto N, Hofte A, Tjaden UR, Gorton L, Marko-Varga G, Bruggink C, & van der Greef J (1998) Microdialysis-introduction high-performance anion-exchange chromatography/ion spray mass spectrometry for monitoring of online-desalted carbohydrate hydrolysates. *J Mass Spectrom* **33**, 334-341.
15. van der Hoeven RAM, Tjaden UR, van der Greef J, van Casteren WHM, Schols HA, Voragen AGJ, & Bruggink C (1998) Recent progress in high-performance anion-exchange chromatography/ion spray mass spectrometry for molecular mass determination and characterization of carbohydrates using static and scanning array detection. *J Mass Spectrom* **33**, 377-386.
16. Rumbold K, Okatch H, Torto N, Siika-Aho M, Gubitza G, Robra KH, & Prior B (2002) Monitoring on-line desalted lignocellulosic hydrolysates by microdialysis sampling micro-high performance anion exchange chromatography with integrated pulsed electrochemical detection/mass spectrometry. *Bio-technol Bioeng* **78**, 822-828.
17. Richardson S, Cohen A, & Gorton L (2001) High-performance anion-exchange chromatography-electrospray mass spectrometry for investigation of the substituent distribution in hydroxypropylated potato amylopectin starch. *J Chromatogr A* **917**, 111-121.
18. Rocklin RD, Clarke AP, & Weitzhandler M (1998) Improved long-term reproducibility for pulsed amperometric detection of carbohydrates via a new quadruple-potential waveform. *Anal Chem* **70**, 1496-1501.
19. Packer NH, Lawson MA, Jardine DR, & Redmond JW (1998) A general approach to desalting oligosaccharides released from glycoproteins. *Glycoconj J* **15**, 737-747.
20. Small, H. (1989) *Ion Chromatography*, 1989 edn., pp. 65, Plenum Publishing Corp., New York.
21. Weiss, J. (1995) *Ion Chromatography*, 2 edn., pp. 74, VCH, Weinheim.
22. De Leenheer L (1994) Production and use of inulin: Industrial reality with a promising future. In *Carbohydrates as Organic Raw Materials III* (van Bekkum H, Roper H, & Voragen F, eds), pp. 67-92. CRF, The Hague.
23. Niness KR (1999) Inulin and oligofructose: what are they? *J Nutr* **129**, 1402S-1406S.
24. Yamashita K, Ohkura T, Okada S, Yabuuchi H, & Kobata A (1981) Urinary oligosaccharides of GM1-gangliosidosis. Different excretion patterns of oligosaccharides in the urine of type 1 and type 2 subgroups. *J Biol Chem* **256**, 4789-4798.
25. Klein A, Lebreton A, Lemoine J, Perini JM, Roussel P, & Michalski JC (1998) Identification of urinary oligosaccharides by matrix-assisted laser desorption/ionization time-of-flight mass spectrometry. *Clin Chem* **44**, 2422-2428.
26. Domon B & Costello CE (1988) A Systematic Nomenclature for Carbohydrate Fragmentations in FAB-MS/MS Spectra of Glycoconjugates. *J Glycoconj* **5**, 397-409.
27. Spina E, Sturiale L, Romeo D, Impallomeni G, Garozzo D, Waidelich D, & Glueckmann M (2004) New fragmentation mechanisms in matrix-assisted laser desorption/ionization time-of-flight/time-of-flight tandem mass spectrometry of carbohydrates. *Rapid Commun Mass Spectrom* **18**, 392-398.
28. Harvey DJ (2000) Electrospray mass spectrometry and fragmentation of N-linked carbohydrates derivatized at the reducing terminus. *J Am Soc Mass Spectrom* **11**, 900-915.
29. Weiskopf AS, Vouros P, & Harvey DJ (1998) Electrospray ionization-ion trap mass spectrometry for structural analysis of complex N-linked glycoprotein oligosaccharides. *Anal Chem* **70**, 4441-4447.

30. van der Hoeven RAM, Hofte AJP, Tjaden UR, van der Greef J, Torto N, Gorton L, Marko-Varga G, & Bruggink C (1998) Sensitivity improvement in the analysis of oligosaccharides by online high-performance anion-exchange chromatography/ion-spray mass spectrometry. *Rapid Commun Mass Spectrom* **12**, 69-74.
31. Hommes FA & Varghese M (1991) High-performance liquid chromatography of urinary oligosaccharides in the diagnosis of glycoprotein degradation disorders. *Clin Chim Acta* **203**, 211-224.

