

Cover Page



Universiteit Leiden



The handle <http://hdl.handle.net/1887/20909> holds various files of this Leiden University dissertation.

Author: Bruggink, Cornelis

Title: Characterization of oligosaccharides with capillary high performance anion exchange chromatography hyphenated to pulsed amperometric detection and ion trap mass spectrometry

Issue Date: 2013-05-29

2

ANALYSIS OF CARBOHYDRATES BY
ANION-EXCHANGE CHROMATOGRAPHY
AND MASS SPECTROMETRY

2.1 ABSTRACT

A versatile liquid chromatographic platform has been developed for analyzing underivatized carbohydrates using high-performance anion-exchange chromatography (HPAEC) followed by an inert PEEK splitter that splits the effluent to the integrated pulsed amperometric detector (IPAD) and to an on-line single quadrupole mass spectrometer (MS). Common eluents for HPAEC such as sodium hydroxide and sodium acetate are beneficial for the amperometric detection but not compatible with electrospray ionization (ESI). Therefore a membrane-desalting device was installed after the splitter and prior to the ESI interface converting sodium hydroxide into water and sodium acetate into acetic acid. To enhance the sensitivity for the MS detection, 0.5 mmol/l lithium chloride was added after the membrane desalter to form lithium adducts of the carbohydrates. To compare sensitivity of IPAD and MS detection glucose, fructose, and sucrose were used as analytes. A calibration with external standards from 2.5 to 1000 pmole was performed showing a linear range over three orders of magnitude. Minimum detection limits (MDL) with IPAD were determined at 5 pmole levels for glucose to be 0.12 pmole, fructose 0.22 pmole and sucrose 0.11 pmole. With MS detection in the selected ion mode (SIM) the lithium adducts of the carbohydrates were detected obtaining MDL's for glucose of 1.49 pmole, fructose 1.19 pmole, and sucrose 0.36 pmole showing that under these conditions IPAD is 3–10 times more sensitive for those carbohydrates. The applicability of the method was demonstrated analyzing carbohydrates in real world samples such as chicory inulin where polyfructans up to a molecular mass of 7000 g/mol were detected as quadruple charged lithium adducts. Furthermore mono-, di-, tri-, and oligosaccharides were detected in chicory coffee, honey and beer samples.

Cees Bruggink^a, Rolf Maurer^b, Heiko Herrmann^c, Silvano Cavalli^d, Frank Hoefler^e

^aDionex B.V., Lange Bunder 5, 4854 MB Bavel, The Netherlands

^bDionex (Switzerland) AG, Solothurnerstrasse 259, CH-4600 Olten, Switzerland

^cDionex GmbH, Am Wörtzgarten 10, D-65510 Idstein, Germany

^dDionex S.r.l., Via Tulipani 1, 20090 Pieve Emanuele, Italy

^eDionex (Europe) Management AG, Solothurnerstrasse 259, CH-4600 Olten, Switzerland

Journal of Chromatography A (2005) 1085; 104–109.

2.2 INTRODUCTION

Liquid chromatographic methods play an important role in determining carbohydrates. Normal-phase and porous graphitized carbon allow the separation of underivatized carbohydrates. Underivatized carbohydrates lacks a chromophore and in combination with an isocratic separation refractive index detection can be performed while evaporating light scattering can be used following isocratic and gradient separations [1,2]. A well-established technique for determining underivatized carbohydrates is anion-exchange chromatography (HPAEC) using alkali hydroxide and alkali acetate based eluents [3,4]. The high efficient separation of sugar alcohols, mono-, di- and oligosaccharides up to a degree of polymerization (DP) of 60 is possible [4]. Today, selective and sensitive detection integrated pulsed amperometric detection (IPAD) is used, which is directly compatible with the high ionic strength of these eluents [5].

For verification of the identity of individual sugars the retention times of the peaks are compared with those obtained from reference solutions. Fractions are collected of unknown peaks and identified offline by MS, NMR or other techniques [6].

For further development of carbohydrate analysis online MS detection is required for faster and more reliable identification and peak conformation according to their mass to charge ratio. Interfacing anion-exchange chromatography with mass spectrometric detection is a technological challenge. Typical alkali acetate and hydroxide eluents are not compatible with atmospheric pressure ionization (API) due to their non-volatility and high conductance, therefore, a desalting device is installed between the column and the MS. The desalter converts the alkali hydroxide and acetate into water and acetic acid continuously exchanging the alkali cations by hydronium ions using a selective cation-exchange membrane and a regenerant [4,7].

To enhance sensitivity of the neutral carbohydrates, 0.5 mmol/l LiCl is added after the desalter and prior to the MS using a T-piece and an auxiliary pump. Lithium chloride is forming charged complexes with carbohydrates. The sugars can be detected as Li-adducts $[M + Li]^+$ at $[M + 7]^+$ in the positive mode or as chloride adducts in negative mode $[M + Cl]^-$, while the positive charged complexes are detected with higher sensitivity.

In source collision induced fragmentation (CID) of carbohydrates after ESI can be achieved in single quadrupole MS accelerating the ions into the focusing RF lens region with a high enough voltage applied to the exit cone. The formed fragment ions are from glycosidic cleavage and can confirm that an unknown eluting peak is a carbohydrate or not.

In the analytical system, the MS detector and the amperometric detection cell are placed in parallel after the analytical column with the aid of a flow splitter.

When normal bore columns are used, the amperometric detection cell and the MS detector are usually installed in series. When narrow bore columns are used, there will be a higher degree of loss of separation when they are installed in series than when they are installed in parallel. The main cause of this loss in chromatographic efficiency is the void volume of the reference electrode cavity in the amperometric cell.

The system is evaluated in isocratic separation mode for mono- and disaccharides. Here the MS detection is compared to the IPAD detection for response and minimum detection limit. Then employability for gradient separation is shown with a native inulin sample.

The applicability of food and beverage samples for the analyses of neutral carbohydrates will be shown. Oligosaccharides are analyzed in a native inulin sample, chicory coffee, lager beer and honey.

2.3 EXPERIMENTAL

2.3.1 Chemicals

Sodium hydroxide (50%, w/w) and sodium acetate were obtained from J.T. Baker (Deventer, The Netherlands). Fresh demineralized water was obtained from an Elga Purelab Ultra Analytic system from Rossmark Waterbehandeling B.V. (Ede, The Netherlands). Chicory inulin was a sample from Warcoing Research (Belgium, Warcoing).

2.3.2 Instrumentation

The schematic drawing of the complete chromatographic system is depicted in Fig. 2-1. The BioLC system from Dionex (Sunnyvale, CA, USA) consisted of a GP50 low-pressure quaternary gradient pump, an ED50A electrochemical detector, an AS50 autosampler with sample cooling, thermal compartment for thermal stabilizing of the column and amperometric cell and a 25 μ l injection loop. The single quadrupole MS used, was manufactured by Thermo Electron for Dionex.

To pump the 0.5 mmol/l LiCl solution at a flow rate of 0.05 ml/min, an AXP-MS auxiliary pump from Dionex was used. To control the complete system and to realize data acquisition and analysis the Chromeleon® chromatography management system from Dionex was used.

2.3.2.1 Analytical column

The separation was performed on a CarboPac PA200 (3 mm \times 250 mm) with a CarboPac PA200 guard (3 mm \times 50 mm) column from Dionex. The stationary phase is a 5.5 μ m diameter

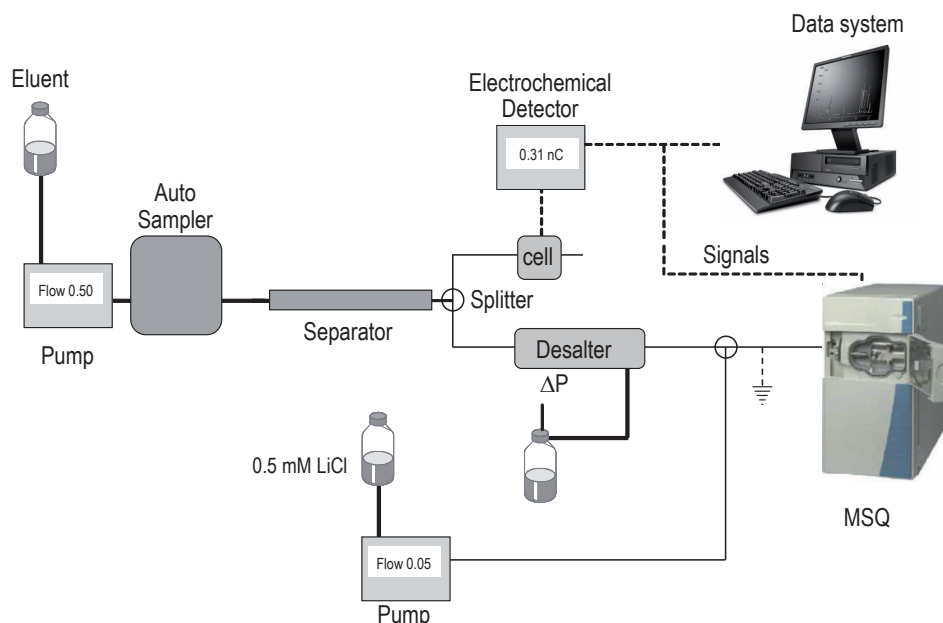

Figure 2-1. Schematics of the chromatographic system.

ethylvinylbenzene/divinylbenzene substrate (55% cross-linking), agglomerated with 34 nm MicroBead™ 6% cross-linked quaternary amine functionalized latex.

2.3.2.2 Flow splitter for detection

To split the effluent after the analytical column a flow splitter was built entirely from PEEK material (Scivex Upchurch Scientific Division, USA). The splitter consisted of a Micro-TEE (P-775) and two PEEK tubings (300 mm×0.075 mm I.D.). One of the PEEK tubings was connected between the MicroTEE and the electrochemical detection cell and the other tubing was connected to the MicroTEE and desalter for the MS detection. PEEK material was used because of inertness. To avoid changing of the split ratio, due to varying backpressure from the ESI probe during optimizing the probe temperature, the total backpressure of the splitter was set to 1.4MPa. The internal volume (1.5 µl) of the splitter resulted in no extra band broadening. The split ratio of the flow splitter is 1:1.

2.3.2.3 Desalter

A cation-exchange membrane in the acid-form was used, as an in-line desalter, to convert the eluate into an ESI compatible solution. The membrane was continuously regenerated with acid generated by electrolysis of water. It efficiently exchanges Na⁺ ions originated from the eluent for H₃O⁺ ions [7-9]. Neutral and anionic compounds will pass the desalter to the mass spectrometer. As desalter, an ASRS Ultra II 2mm (volume <15 µl) from Dionex was used. The water was fed from an air-pressurized bottle into the regenerant chamber at a flow rate of 5 ml/min. For the isocratic separation conditions a regenerant current of 45 mA was applied and for the gradient conditions 286 mA.

2.3.3 Detection

The ED50A detector delivered to the electrochemical cell the following potential waveform: $E_1 = 0.1V$ ($t_d = 0.00-0.20$ s, $t_1 = 0.20-0.40$ s), $E_2 = -2.0V$ ($t_2 = 0.41-0.42$ s) $E_3 = 0.6V$ ($t_3 = 0.43$ s), $E_4 = -0.1V$ ($t_4 = 0.44-0.50$ s) versus a Ag/AgCl reference electrode to a gold work electrode [10]. The standard 25 µm gasket was installed. The inlet stainless steel tube of the cell was removed to reduce internal volume. The PEEK tubing, coming from the flow splitter, was directly connected to the cell.

Neutral carbohydrates were detected in the positive ion mode in the MS after formation of quasi-molecular ions with the added lithium ions. For efficient ionization of the eluted carbohydrates a make-up solution (0.5 mM LiCl) was pumped into the eluent flow at a flow rate of 50 µl/min. This flow was delivered via a MicroTEE (P-775 Scivex). The mixture was directed to the electrospray ionization (ESI) interface of the MSQ quadrupole mass spectrometer. The ESI-MS was operated at the following conditions: probe temperature 525 °C, nitrogen pressure 0.5 MPa, cone voltage 75 volts. When a higher degree of fragmentation was required the cone voltage was set to 100 volts.

2.3.4 Chromatographic conditions

Isocratic separation was done with a flow rate of 0.50 ml/min at 30 °C and 60 mM NaOH as eluent. A ternary gradient elution with the same flow rate and temperature was used with the following eluents: eluent A, water; eluent B, 600 mM NaOH; eluent C, 500 mM NaOAc.

The gradient was as follows: 80% A+ 20% B (0–5 min) isocratic to convert the column into the hydroxide form; 90% A+ 10% B (5–20 min) isocratic equilibration of the column and after 15 min the sample was injected; 25.5% A+ 10% B+ 64.5% C (20–48 min) linear acetate gradient; 25.5% A+ 10% B+ 64.5% C (48–50 min) isocratic.

2.3.5 Samples

A chicory coffee, a lager beer and a honey were bought off-the-shelf. From the chicory coffee 2.5 g were dissolved in 100 ml demineralized water and filtered through a 0.2 μm membrane filter before injection. The lager beer sample was degassed by placing it for 5 min into an ultrasonic bath and five times diluted with demineralized water prior to injection. From the honey sample 100 mg were diluted to 100 ml with demineralized water and filtered through a 0.2 μm membrane filter before injection.

2.4 RESULTS AND DISCUSSION

2.4.1 Evaluation of the detection performance

To evaluate the sensitivity and selectivity of the system an isocratic separation was used for the separation of glucose, fructose and sucrose, see Fig. 2-2. The three carbohydrates are well separated and from 500 pmol injection a mass spectrum with good signal to noise ratio was obtained, see Fig. 2-3. At a cone voltage of 75V the quasi-molecular ion at m/z 349 is clearly the base peak of sucrose. Also fragment ions from glycosidic cleavages were observed, numbering system proposed by Domon and Costello [11] is used and shown in the same figure. The mass loss of 162 (Y fragment at m/z 187) is a clear indication for a hexose. The fragment ion at m/z 205 is a water adduct of the Y fragment. Such water adducts are easily formed in the ESI of the MSQ mass spectrometer. B fragment ion at m/z 169 is a glycosidic cleavage on the other side of the oxygen atom.

To study the signal response of both detectors a calibration using external standards was performed and the limit of detection was determined, both for IPAD and MS. The calibration range was over 3 orders of magnitude (2.5–1000 pmole) with seven different levels of each carbohydrate. The calibration curve fit of the different signals is reported in Table 2-1.

By repeated injections of 5 pmole of each carbohydrate the minimum detection limit was determined, see Table 2-1 and Fig. 2-4. Selected ion monitoring (SIM) was used to study sensitivity and minimum detection limit of the MS, because the signal to noise ratio in this mode is better than in scan mode with a quadrupole MS. The limit of detection for glucose and fructose is approximately 10 times and for sucrose three times better in pulsed amperometric detection compared to mass spectrometric detection.

2.4.2 Gradient performance of the system

To explore the gradient performance of the chromatographic system a gradient separation was developed for native inulin and is shown in Fig. 2-5. Inulin is mainly a mixture of two linear fructan oligosaccharides (FOS), one with a terminal sucrose (GFn) the other with a fructopyranose (Fm) unit, up to a high degree of polymerization (DP) [12]. Both homologous series have their own retention behavior. Despite good separation, coelution of the FOS is also observed.

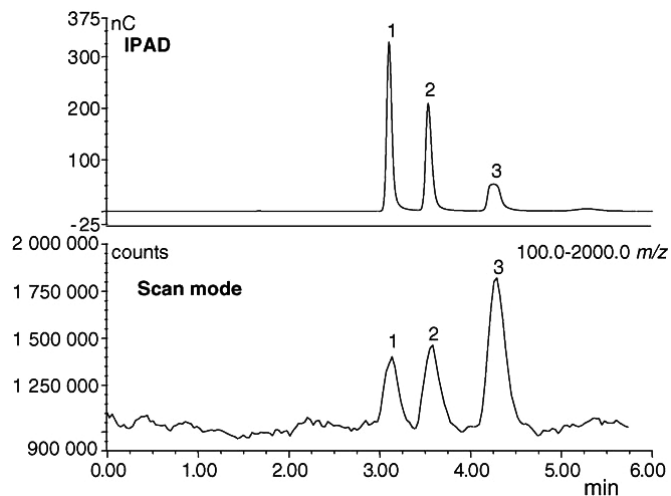

Figure 2-2. Isocratic separation of 500 pmole each of glucose (1), fructose (2) and sucrose (3). The IPAD chromatogram is obtained from the amperometric detector. The lower chromatogram is obtained from the MS in scanning mode for 100–2000 m/z .

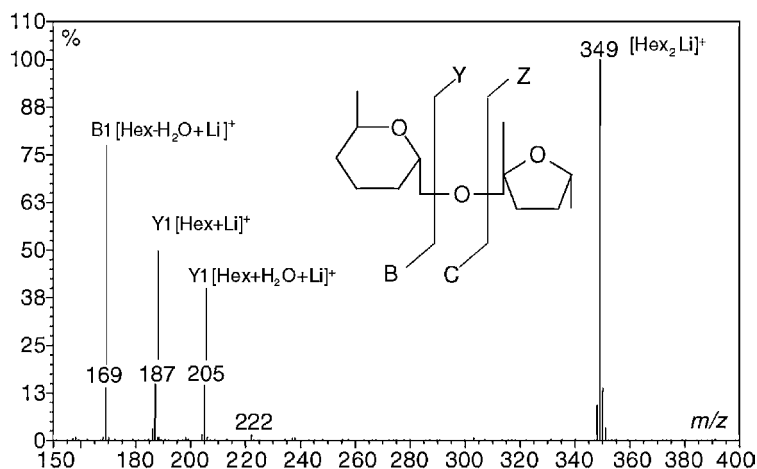

Figure 2-3. Mass spectrum of sucrose.

An example is the peak at 18.24 min. Extracting ion chromatograms from the MS data at appropriate mass to charge ratios, unveiled both series. In Table 2-2 retention times of the fructo-oligosaccharides are reported. Retention times printed in *italics* are indicating coeluting compounds.

As an example of coeluting peaks the mass spectrum in Fig. 2-6 shows two mass peaks, one at m/z 1159 (G_6) and the other one at m/z 835 (F_5). MS data helps to unveil coeluting compounds, because they are not isobaric. Multiple charged adducts were observed for fructan

Table 2-1. Calibration curves and minimum detection limits.

	Curve	Slope	Corr. Coeff.	SIM MDL (pmole)	IPAD MDL (pmole)
Glucose SIM 187	-0.13946	291.988	0.99992	1.49	0.12
Fructose SIM 187	-0.05785	131.603	0.99997	1.19	0.22
Sucrose SIM 349	-0.02718	62.920	0.99998	0.36	0.11

MDL = $t_s \times \sigma$, $n = 7$ based on peak area of 5 pmole. t_s is Students t

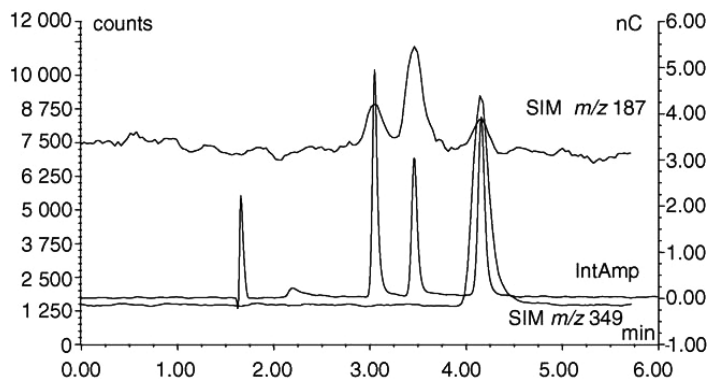
**Figure 2-4.** 5 pmole of glucose, fructose and sucrose. IPAD and SIM channels of m/z 187 and 349.

oligosaccharides with higher molecular mass. From Table 2-2 it can be observed that DP1 to 7 are singly charged adducts, from DP6 to 25 doubly charged adducts with an overlap for DP6 and DP7. Triply charged adducts were observed from DP13 and higher, not shown. Quadruple charged adducts were observed from DP26 and higher, not shown. As an example for multiply charged adducts the mass spectrum of GF_6 is shown in Fig. 2-6. Singly charged GF_6 is observed at m/z 1159 and the double charged lithium adduct of GF_6 at m/z 583. We observed under these conditions for every 1000 Da increase in molecular mass the charge is raised by one extra unit.

2.4.3 Determination of oligohexoses in food and beverage samples

The same gradient conditions as for inulin were used for separating all food and beverage samples. In Figs. 2-7 and 2-8 the resulting chromatograms of chicory coffee and lager beer are shown. The chromatograms obtained in IPAD are very complex showing a high number of unresolved peaks. This is caused by the fact that integrated pulsed amperometric detection is not only selective for carbohydrates, but also for amines like amino acids, peptides, proteins and Maillard reaction products such as Amadori and Heyn's products is expected in these samples. The MS can be of help to identify oligohexoses by extracting mass selective chromatograms. Moreover, the cationic desalter membrane is very acidic and will protonate amines and as a result remove them prior to MS detection.

Extracted ion chromatograms of the chicory coffee sample for mass to charge ratios of neutral oligohexoses show mainly DP1 to DP11. Up to DP8 are shown in Fig. 2-7. The extracted

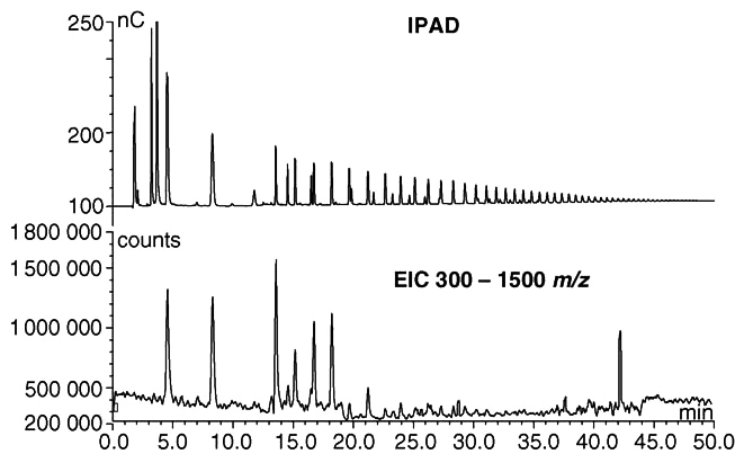

Figure 2-5. Gradient separation of 7.5 µg inulin. The IPAD chromatogram is obtained from the amperometric detector. The lower chromatogram is extracted from the MS data range of m/z 300–1500.

Table 2-2. Retention times and mass to charge ratios of fructan oligosaccharides.

GFn (min)	Fm (min)	DP	Charge		
			$z = +1$	$z = +2$	$z = +3$
8.33	14.55	3	511		
13.56	16.52	4	673		
15.21	18.24	5	835		
16.76	19.89	6	997	502	
18.24	Not found	7	1159	583	
19.69	23.24	8		664	
21.20	24.65	9		745	
22.63	25.96	10		826	
23.91	27.18	11		907	
25.11	28.34	12		988	
26.24	29.22	13		1069	715
27.30		14		1151	769
28.31		15		1232	823

mass selective chromatograms from DP1 to DP8 unveil the retention time ranges of the individual oligosaccharides for example mass to charge ratio at m/z 187 elute from 3 to 5 min, while the pentasaccharides at m/z 835 elute between 14 and 18 min. Fig. 2-8 presents extracted mass chromatograms of DP1 to DP10 of the lager beer sample. Oligohexoses up to DP14 were observed in this sample. In contrast of the chicory coffee sample, the beer sample contains lower concentrations of mono- and disaccharides and relative high concentrations at m/z 511 (DP3) and at m/z 673 (DP4) in comparison to mono- and disaccharides.

The honey sample contains mainly mono- and dihexoses as shown in Fig. 2-9. The chromatogram is relatively simple compared to chicory coffee and beer. Major components

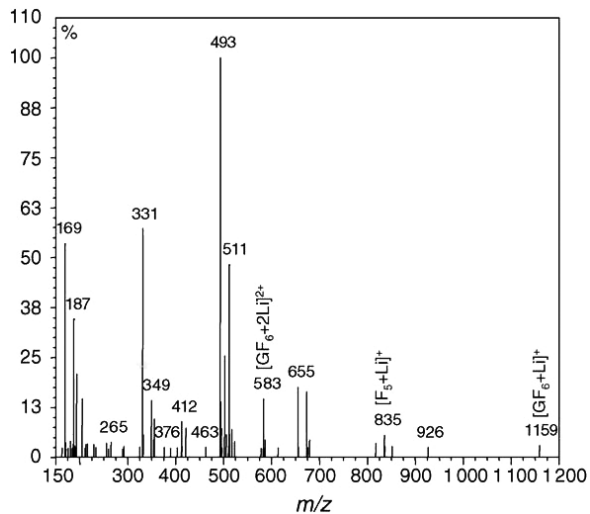

Figure 2-6. Mass spectrum of the peak at retention time 18.24 min.

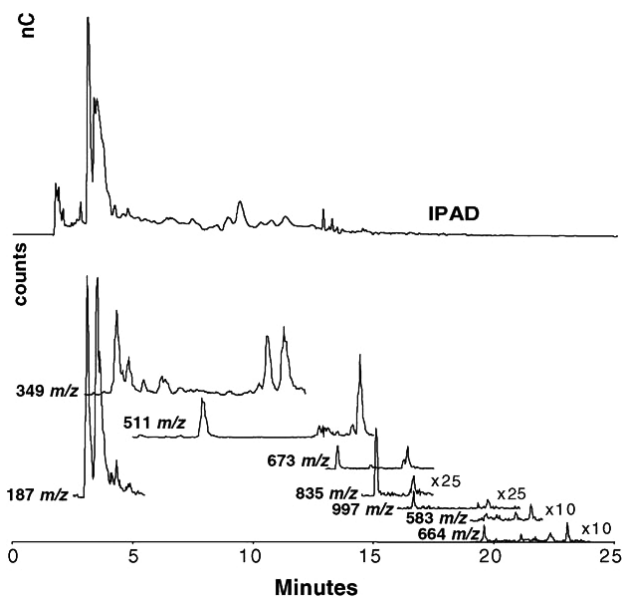

Figure 2-7. Chicory coffee 25 mg/ml, 25 μ l injected. The upper chromatogram is obtained from the amperometric detector. The lower signals are mass extracted chromatograms of oligohexoses up to DP8.

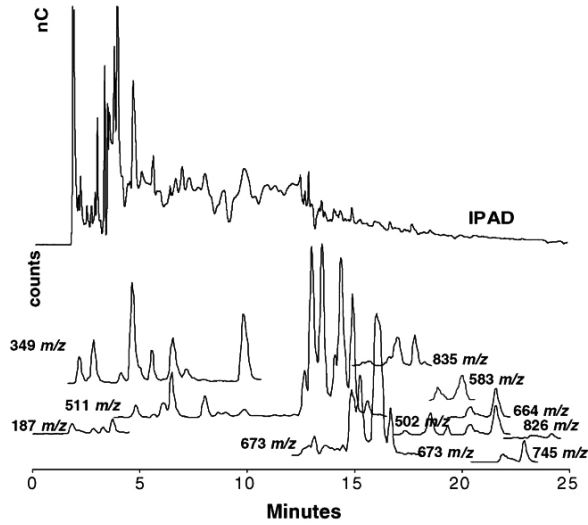

Figure 2-8. Lager beer degassed 5x diluted, 25 μ l injected. The upper chromatogram is obtained from the amperometric detector. The lower signals are mass extracted chromatograms of oligohexoses up to DP10.

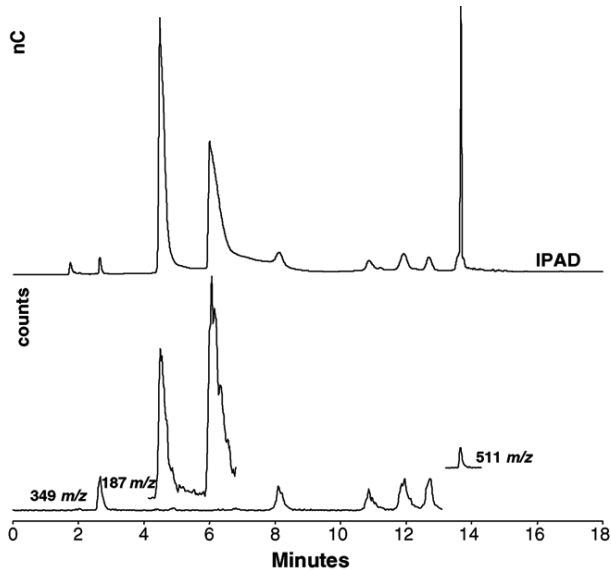

Figure 2-9. Honey 1 mg/ml, 5 μ l injected. The upper chromatogram is obtained from the amperometric detector. The lower signals are mass extracted chromatograms of oligohexoses up to DP3.

are the monosaccharides and low abundant are the di- and trisaccharides. These examples show the broad applicability of the chromatographic platform determining carbohydrates in complex samples with minimal sample preparation.

2.5 CONCLUSIONS

A versatile narrow bore column liquid chromatography platform has been developed for the analysis of underivatized carbohydrates. Applicability is shown with complex food and beverage samples. It demonstrates the successful combination of integrated pulsed amperometric and an on-line single quadrupole mass spectrometric detection, following gradient anion-exchange separation. Although there can be significant sensitivity differences between the MS and IPAD detection, mass selective detection is beneficial for confirmation of sugars in food and beverage samples. In source formed fragment ions can confirm that unknown components are carbohydrates. Only cleavages of glycosidic linkages were observed. The resulting mass loss of a monosaccharide unit is a very strong indication for detecting carbohydrates. Coelutions of compounds can be determined with MS detection. The different isobaric polyfructan chains in inulin with terminal fructose or sucrose are identified according to their mass to charge ratio and retention times. Multiple charged Li adduct formation is observed as high as four for molecule masses above 4200 g/mol (DP 26), enabling use of a single quadrupole mass spectrometer with an upper mass range of 2000 m/z to detect the higher molecular weight compounds.

REFERENCES

1. Honda S (1984) High-performance liquid chromatography of mono- and oligosaccharides. *Anal Biochem* **140**, 1-47.
2. Anumula KR (2000) High-sensitivity and high-resolution methods for glycoprotein analysis. *Anal Biochem* **283**, 17-26.
3. Lee YC (1990) High-performance anion-exchange chromatography for carbohydrate analysis. *Anal Biochem* **189**, 151-162.
4. Cataldi TR, Campa C, & De Benedetto GE (2000) Carbohydrate analysis by high-performance anion-exchange chromatography with pulsed amperometric detection: the potential is still growing. *Fresenius J Anal Chem* **368**, 739-758.
5. Rocklin RD, Tullsen TR, & Marucco MG (1994) Maximizing signal-to-noise ratio in direct current and pulsed amperometric detection. *J Chromatogr A* **671**, 109-114.
6. Lee KB, Loganathan D, Merchant ZM, & Linhardt RJ (1990) Carbohydrate analysis of glycoproteins. A review. *Appl Biochem Biotechnol* **23**, 53-80.
7. Thayer JR, Rohrer JS, Avdalovic N, & Gearing RP (1998) Improvements to in-line desalting of oligosaccharides separated by high-pH anion exchange chromatography with pulsed amperometric detection. *Anal Biochem* **256**, 207-216.
8. van der Hoeven RAM, Tjaden UR, van der Greef J, van Casteren WHM, Schols HA, Voragen AGJ, & Bruggink C (1998) Recent progress in high-performance anion-exchange chromatography/ion-spray mass spectrometry for molecular mass determination and characterization of carbohydrates using static and scanning array detection. *J Mass Spectrom* **33**, 377-386.
9. Torto N, Hofte A, Tjaden UR, Gorton L, Marko-Varga G, Bruggink C, & van der Greef J (1998) Microdialysis-introduction high-performance anion-exchange chromatography/ion-spray mass spectrometry for monitoring of online-desalted carbohydrate hydrolysates. *J Mass Spectrom* **33**, 334-341.
10. Rocklin RD, Clarke AP, & Weitzhandler M (1998) Improved long-term reproducibility for pulsed amperometric detection of carbohydrates via a new quadruple-potential waveform. *Anal Chem* **70**, 1496-1501.

-
11. Domon B & Costello CE (1988) A Systematic Nomenclature for Carbohydrate Fragmentations in FAB-MS/MS Spectra of Glycoconjugates. *J Glycoconj* **5**, 397-409.
 12. De Leenheer F (1996) Production and use of inulin: Industrial reality with a promising future. In *Carbohydrates as Organic Raw Materials III* (van Bekkum H, Roper H, & Voragen F, eds), pp. 67-92. CRF, The Hague.