



Universiteit
Leiden
The Netherlands

Genetic causes of growth disorders

Duyvenvoorde, H.A. van

Citation

Duyvenvoorde, H. A. van. (2013, June 25). *Genetic causes of growth disorders*. Retrieved from <https://hdl.handle.net/1887/21013>

Version: Corrected Publisher's Version

License: [Licence agreement concerning inclusion of doctoral thesis in the Institutional Repository of the University of Leiden](#)

Downloaded from: <https://hdl.handle.net/1887/21013>

Note: To cite this publication please use the final published version (if applicable).

Cover Page



Universiteit Leiden



The handle <http://hdl.handle.net/1887/21013> holds various files of this Leiden University dissertation.

Author: Duyvenvoorde, Hermine van

Title: Genetic causes of growth disorders

Issue Date: 2013-06-25

2



Short stature associated with a novel heterozygous mutation in the *insulin-like growth factor 1* gene

H.A. van Duyvenvoorde^{1,2,3}, P.A. van Setten⁴, M.J.E. Walenkamp^{1,5}, J. van Doorn⁶, J. Koenig⁷, L. Gauguin⁷, W. Oostdijk¹, C.A.L. Ruivenkamp³, M. Losekoot³, J.D. Wade⁸, P. De Meyts⁷, M. Karperien^{2,9}, C. Noordam¹⁰, and J.M. Wit¹

¹Department of Pediatrics, ²Department of Endocrinology and Metabolic Diseases, ³Center for Human and Clinical Genetics, Leiden University Medical Center, Leiden, The Netherlands

⁴Department of Pediatrics, Alysis Zorggroep Ziekenhuis Rijnstate, Arnhem, The Netherlands

⁵Department of Pediatrics, VU University Medical Center, Amsterdam, The Netherlands

⁶Department of Metabolic and Endocrine Diseases, and Laboratory of Clinical Chemistry and Hematology, University Medical Center Utrecht, Utrecht, The Netherlands

⁷Receptor Systems Biology Laboratory, Hagedorn Research Institute, Gentofte, Denmark

⁸Howard Florey Institute, University of Melbourne, Melbourne, Australia

⁹Department of Tissue Regeneration, MIRA Institute for Biomedical Technology and Technical Medicine, University of Twente, Enschede, The Netherlands

¹⁰Department of Pediatrics, Radboud University Nijmegen Medical Center, Nijmegen, The Netherlands

The Journal of Clinical Endocrinology & Metabolism 2010;95(11):E363–367

Abstract

Context: Homozygous *IGF1* deletions or mutations lead to severe short stature, deafness, microcephaly and mental retardation. Heterozygosity for an IGF-I defect may modestly decrease height and head circumference.

Objective: The objective of the study was to investigate the clinical features of heterozygous carriers of a novel mutation in the *IGF1* gene in comparison with noncarriers in a short family and to establish the effect of human GH treatment.

Subjects: Two children, their mother, and their maternal grandfather carried the mutation and were compared with two relatives who were noncarriers.

Results: The two index cases had severe short stature (height SD Score -4.1 and -4.6), microcephaly, and low IGF-I levels. Sequencing of *IGF1* revealed a heterozygous duplication of four nucleotides, resulting in a frame shift and a premature termination codon. The mother and maternal grandfather had the same *IGF1* mutation. Adult height (corrected for shrinking and secular trend) and head circumference SD Score of carriers of the paternally transmitted mutation was -2.5 and -1.8 , in comparison with -1.6 and 0.3 in noncarriers, respectively. After 2 yr of GH treatment, both index cases exhibited increased growth.

Conclusions: Heterozygosity for this novel *IGF1* mutation in children born from a mother with the same mutation, presumably in combination with other genetic factors for short stature, leads to severe short stature, which can be successfully treated with GH.

Introduction

Insulin-like growth factor-I (IGF-I) plays a critical role in the regulation of pre- and postnatal growth and development in humans and rodents (1;2). Prenatal IGF-I production is largely growth hormone (GH) independent, and is mainly affected by placental sufficiency, fetal nutrition, and insulin (3). Postnatally IGF-I production and secretion is predominantly regulated by GH and nutrition (1). IGF-I can be synthesized by almost any tissue in the body, but circulating IGF-I is mainly produced in the liver (4).

A total IGF-I deficiency caused by a homozygous *IGF1* deletion or missense mutation, leads to severe intrauterine and postnatal growth failure, microcephaly, mental retardation, and sensorineural deafness (5;6). In another patient with the same phenotype, a homozygous nucleotide substitution located in the upstream core polyadenylation signal at the 3' untranslated region in exon 6 of *IGF1* was reported (7), later shown to be a polymorphism (8). Recently a fourth patient was described with a homozygous missense *IGF1* mutation (9), exhibiting intrauterine and postnatal growth failure, microcephaly, mild intellectual impairment, but normal hearing.

There is some evidence that heterozygosity for an *IGF1* defect is associated with a modest decrease of height. The eight heterozygous carriers of the *IGF1* deletion had a height between -0.6 and -2.1 SD Score (SDS), and serum IGF-I was below the normal range in five (5;10). The nine heterozygous carriers of the missense mutation showed a subtle, but statistically significant, inhibition of intrauterine and postnatal statural and cranial growth (6).

In this report we describe two children with severe short stature and a maternally derived novel heterozygous mutation in exon 3 of the *IGF1* gene and their relatives. All subjects provided written informed consent.

Materials and Methods

Clinical, radiological, and audiometric measurements

A full physical examination was performed as described previously (11). Bone mineral density was measured by dual-energy x-ray absorptiometry using the Hologic Scanner (QDR 4500; Hologic, Waltham, MA) at the lumbar spine and femoral neck. Z-scores were calculated as a function of age, sex, and ethnicity for a matched population using the Hologic reference database. Hearing ability at different sound frequencies (500–4000 Hz) was measured with an AC40 clinical audiometer (Interacoustics, Eden Prairie, MN).

Biochemical measurements

Plasma acid-labile subunit (ALS), IGF-I, IGF-II, IGF binding protein (IGFBP)-1, IGFBP-2, IGFBP-3, IGFBP-4, and IGFBP-6 were determined as described previously (6). Serum insulin levels, after an overnight fast, were determined by a semiautomatic luminescence method (Immulite 1000; Siemens Medical Solutions Diagnostics, Los Angeles, CA). GH levels are expressed as micrograms per liter (conversion rate 1 µg/liter = 3.0 IU, standard World Health Organization international standard 98/574).

Molecular studies with genomic DNA of the family members

Genomic DNA was isolated from whole blood (12). All exons of *IGF1* (GenBank accession number NM_000618) were sequenced as described previously (6).

For the analysis of single-nucleotide polymorphisms, the Affymetrix GeneChip human mapping 262K *NspI* array (Affymetrix, Santa Clara, CA) was used. Detection of copy number changes was performed using Copy Number Analyser for GeneChip (CNAG) version 2.0 (www.genome.umin.jp/) (13;14).

Results

Subjects

Clinical and biochemical features are shown in Table 1. Adult height SDS is corrected for shrinking and secular trend (15).

Index case III-1 was born after an uncomplicated 40-wk pregnancy. There were feeding difficulties in infancy, slow motor development, poor growth, and delayed bone age (2.5 yr at 5.9 yr) (Supplemental Fig. 1A). She had a prominent forehead, thin lips, and fine eyebrows. IGF-I was low, but GH maximum during two provocation tests was normal (10.7 µg/liter, normal >6.7 µg/liter). At an IGF-I generation test (1), baseline plasma IGF-I was -2.7 SDS and IGFBP-3 was 0.3 SDS. Only on the highest GH dose IGF-I normalized (-0.6 SDS).

Her younger brother (index case III-2) was born after an uncomplicated 42-wk pregnancy. Besides cow milk allergy and asthma, there were no medical problems, except poor growth and delayed bone maturation (Supplemental Fig. 1B). He had a prominent forehead. Plasma IGF-I was low and the peak GH response to arginine borderline (5.6 µg/liter).

Case II-3, the father of the index cases, had a height of -1.3 SDS, a head circumference (HC) of -1.0 SDS and normal IGF-I and IGFBP-3.

Their mother (case II-2) had feeding problems in infancy and poor growth. At 8.5 yr, height SDS was -3.0 (16), and the GH peak after exercise was 11.5 µg/liter. Breast development started at 11.3 yr at a height of 131.0 cm, and pubertal height gain was only 16.2 cm.

The mother's sister (case II-1) was also short as a child (height SDS -2.0) (16). Her pubertal growth spurt started at 9.75 yr at a height of 128.0 cm, and pubertal height gain was

28.5 cm. The GH peak after exercise was 6.3 µg/liter.

Their maternal grandfather (case I-1), born in 1941, was admitted to the hospital in the first 6 months for failure to thrive. Since 32 yr of age, he is known with poor bone quality, overweight, early dementia, chronic diarrhea, headache, reflux esophagitis due to a hernia diaphragmatica, gout, and a cataract. Reportedly his father, as well a several members of his father's family, was short.

Case I-2, the probands' maternal grandmother, had always been healthy without any medication.

Molecular studies with genomic DNA of the family members

Sequence analysis of *IGF1* of cases I-1, II-2, III-1, and III-2 revealed a heterozygous duplication, indicated as +/-, of four nucleotides, resulting in a frame shift at position 35 of the mature IGF-I protein and a premature stopcodon (c.243_246dupCAGC, p.Ser83GlnfsX13) (<http://www.hgvs.org/mutnomen/recs-prot.html>). The other family members did not carry the mutation (+/+) (Fig. 1).

Sequence analysis of *FGFR3* in cases II-2, III-1 and III-2 and *SHOX* in cases II-2 and III-1 showed no abnormalities. Case III-2 showed a 47,XYX karyotype. His sister (case III-1) and father (case II-3) had a normal karyotype.

Single-nucleotide polymorphism array analysis showed an interstitial deletion (rs13073496 to rs1119180) of about 0.4 Mb on chromosome 3q26.1 in cases I-1, II-1, II-2, III-1 and III-2. All these subjects, except case II-1, are also heterozygous carriers of the *IGF1* mutation (Fig. 1). The deleted area does not contain any genes or noncoding RNAs. None of the known variations in the Database of Genomic Variants in this region (<http://projects.tcag.ca/variation/>) had 100% overlap with this deletion.

Comparison of clinical and biochemical features between carriers and noncarriers of the IGF-I mutation

Carriers of the *IGF1* mutation tended to have a lower height SDS (-3.4 vs. -1.6, $P = 0.172$) and had a significantly lower HC (-1.9 vs. 0.3, $P = 0.002$). In case II-2, bone mineral density was normal. Tone audiometry in the two probands was normal. In carriers plasma IGF-I was lower than in noncarriers ($P = 0.004$).

Response to GH treatment

Both index cases received GH (1.4 mg/m²/day) (Supplemental Fig. 1), which was well tolerated. After 2 yr, height SDS in case III-1 increased by +1.0, she remained prepubertal, and plasma IGF-I rose from -2.6 to +0.6 SDS. IGFBP-3 increased from -0.4 to +0.5 SDS. In case III-2 height SDS increased by +1.5 SD, IGF-I from -2.4 to +0.3 SDS, and IGFBP-3 from -1.0 to +0.3 SDS.

Table 1 Clinical features and biochemical characteristics of the heterozygous and noncarriers

	I-1	II-2	III-1	III-2	I-2	II-1
<i>IGF1</i> gene	+/-	+/-	+/-	+/-	+/+	+/+
Gender	M	F	F	M	F	F
Age (yr)	65.2	35.5	8.2	6.2	64.5	37.2
Birth weight (kg) [SDS]	n.a.	2.8 [-1.6]	2.3 [-2.9]	3.3 [-1.2]	4.0-5.0	3.0 [-1.1]
Birth length (cm) [SDS]	n.a.	47 [-1.6]	44 [-3.8]	50 [-1.0]	n.a.	48 [-1.1]
Height (cm) [SDS] ^a	164 [-1.4]	147.2 [-3.5]	108.9 [-4.1]	98.7 [-4.6]	153.2 [-1.2]	156.5 [-2.0]
HC (cm) [SDS]*	54.7 [-1.8]	52.5 [-1.7]	47.8 [-2.4]	49.0 [-1.6]	55.5 [0.1]	56.0 [0.4]
BMI (kg/m ²) [SDS]	28.6 [3.5]	31.3 [4.7]	14.1 [-1.3]	13.5 [-1.6]	27.0 [2.7]	40.0 [8.8]
Sitting height: height [SDS]	0.54 [1.7]	0.55 [2.2]	0.55 [1.6]	0.57 [2.5]	0.53 [0.7]	0.55 [1.7]
IGF-I (ng/ml) [SDS]	66 [-2.0]	87 [-1.8]	76 [-2.3]	35 [-2.6]	126 [0.6]	131 [-0.4]
IGF-II (ng/ml) [SDS]	529 [1.6]	599 [1.7]	640 [2.0]	542 [1.4]	665 [3.0]	719 [2.8]
IGFBP-1 (ng/ml) [SDS] ^b	23	5	143 [0.3]	378 [1.3]	62	7
IGFBP-2 (ng/ml) [SDS]	143 [-0.6]	83 [-1.7]	155 [-1.3]	288 [0.2]	244 [0.5]	81 [-1.7]
IGFBP-3 (mg/liter) [SDS]	2.0 [0.1]	2.8 [0.8]	3.6 [1.2]	2.1 [0.1]	3.3 [2.0]	2.7 [0.7]
IGFBP-4 (ng/ml) [SDS]	242 [1.1]	212 [0.6]	109 [-1.4]	117 [-1.1]	184 [-0.1]	133 [-0.9]
IGFBP-6 (ng/ml) [SDS]	252 [1.0]	148 [0.2]	83 [-1.1]	89 [-0.3]	131 [-0.9]	141 [0.0]
ALS (mg/liter) [SDS]	16.6 [-0.1]	22.8 [0.3]	20.1 [1.1]	11.5 [-0.4]	20.7 [1.2]	24.8 [0.7]
Insulin (IU/liter) ^c	8.5	22.2	< 2.0	< 2.0	< 2.0	9.6

To convert IGF-I to nanomoles per liter, multiply by 0.131; to convert IGF-II to nanomoles per liter, multiply by 0.134; to convert ALS to nanomoles per liter, multiply by 15.8; to convert IGFBP-1 to nanomoles per liter, multiply by 0.033; to convert IGFBP-2 to nanomoles per liter, multiply by 0.032; to convert IGFBP-3 to nanomoles per liter, multiply by 33.3; to convert IGFBP-4 to nanomoles per liter, multiply by 0.038; to convert IGFBP-6 to nanomoles per liter, multiply by 0.034. n.a., Not available; BMI, body mass index; ALS, acid-labile subunit.

^a Adult height SDS is corrected for shrinking and secular trend by the equations of Niewenweg *et al.* (15).

^b Normal range for nonfasting subjects is 24–57 ng IGFBP-1 per milliliter. After overnight fasting there is an average 5-fold rise in normal individuals. IGFBP-1 SDS values are not available for adults older than 24 yr.

^c Normal range for healthy subjects after overnight fasting is less than 25 IU/liter.

* Statistical difference between heterozygous and wild-type family members.

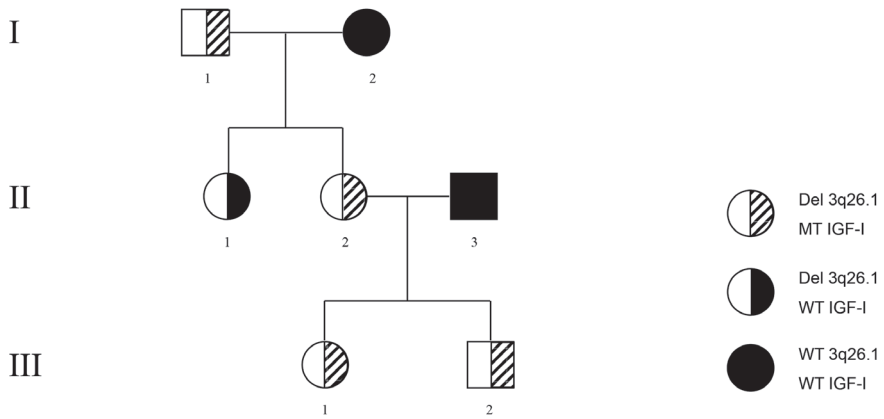

Figure 1

Pedigree of the family. The heterozygous carriers of the *IGF1* mutation are indicated with a *diagonally striped right half of the symbol* and the noncarriers are indicated with a *filled black right half*. The carriers of the 3q26.1 deletion are indicated with a *white left half of the symbol* and the noncarriers are indicated with a *filled black left half*. On the right, the different combinations of wild-type (WT) or mutant (MT) *IGF1* and deleted or normal 3q26.1 is explained. On the left the generation number is indicated and the family number is indicated below each individual.

Discussion

We have shown that heterozygosity for a maternally derived *IGF1* frameshift mutation is associated with severe short stature and microcephaly. The probands' mother, who inherited the same mutation from her father, was less short than the two probands. However, she was still shorter and had a smaller HC and lower plasma IGF-I than her sister, who is not carrying the mutation. This suggests that the combination of maternal and fetal IGF-I deficiency may have had a larger effect on growth than fetal IGF-I deficiency alone, similar to previous observations in a family with an *IGF1R* defect (11). Most carriers had feeding difficulties in infancy, comparable with that observed in patients with homozygous *IGF1* and heterozygous *IGF1R* defects (5;6;11;17). Biochemically, GH secretion was not elevated, similarly to observations in children with IGF-I receptor defects (17) and mice with brain-targeted inactivation of *igf1r* (18). Long-term GH treatment of the probands resulted in a good growth response. Mutant IGF-I was synthesized and used for several *in vitro* experiments. It could not bind to the IGF-I receptor or antagonize the growth-promoting effect of IGF-I. It could bind to IGF-BPs but was not incorporated into 150-kDa complexes (data not shown). Details will be reported elsewhere.

We hypothesize that the severe short stature in the two probands might be caused by a cumulative effect of three factors: 1) *IGF1* haploinsufficiency; 2) placental dysfunction due to maternal *IGF1* haploinsufficiency; and 3) other genetic factors associated with (mild) short stature.

The first part of our hypothesis is supported by the observation that case II-2 was in childhood 1 SD and in adulthood 1.5 SD shorter than her wild-type sister (case II-1). Indirect support comes from our previous study showing that heterozygosity for a missense *IGF1* mutation leads to a 0.6 SD lower height, as well as an inhibition of intrauterine and cranial growth (6;19). The heterozygous carriers of an *IGF1* deletion also exhibited reduced height (5;10). The difference between pubertal height gain in cases II-2 and II-1 suggests that IGF-I deficiency may have a strong impact on pubertal growth.

The second part is based on the observation that birth length (−3.8 SDS) and childhood height (−4.1 SDS) of case III-1 is 1–2 SD lower than of her mother (−1.6 and −3.0 SDS, respectively). It is further supported by our previous observations in a family with an *IGF1R* mutation (11), in which the proband's length was much more affected than in her mother, who did not inherit the mutation maternally. Some more indirect evidence for such effect of maternal IGF-I deficiency on placental and fetal growth includes the strong correlation between the rate of IGF-I increase during pregnancy and placental weight (11). Furthermore, placentas from intrauterine growth retardation pregnancies are characterized by decreased expression of IGF-I receptor and associated signal transduction proteins (11).

With respect to the third part (other genetic factors), we have found no other gene defects in this family, except for an interstitial deletion on chromosome 3q26.1 in most cases. There is no evidence linking this region to short stature. Interestingly, the male proband has a 47,XYY karyotype, known to be associated with tall stature. This may have mitigated the negative effect of IGF-I deficiency on intrauterine growth and may have increased his growth response to GH.

In conclusion, our observations suggest that maternally and paternally derived *IGF1* haploinsufficiency leads to a height loss of 2 and 1 SD, respectively, and to a smaller HC, in comparison with wild-type relatives. In combination with a familial predisposition for short stature, this can lead to a height far below the normal range, which can be treated successfully with GH.

Acknowledgments

We thank Dr. K. Woods and Professor M.O. Savage for sharing unpublished data on heterozygous carriers of the IGF-I deletion and Dr. L. Schäffer for preparing one batch of the mutant peptide. We also thank Dr. M. Jansen for providing clinical information on cases II-1 and II-2.

Reference List

1. Walenkamp MJ, Wit JM 2006 Genetic disorders in the growth hormone - insulin-like growth factor-I axis. *Horm Res* 66:221-230
2. Walenkamp MJ, Wit JM 2007 Genetic disorders in the GH IGF-I axis in mouse and man. *Eur J Endocrinol* 157 Suppl 1:S15-S26
3. Rosenfeld RG 2003 Insulin-like growth factors and the basis of growth. *N Engl J Med* 349:2184-2186
4. Rosen CJ 1999 Serum insulin-like growth factors and insulin-like growth factor-binding proteins: clinical implications. *Clin Chem* 45:1384-1390
5. Woods KA, Camacho-Hubner C, Savage MO, Clark AJ 1996 Intrauterine growth retardation and postnatal growth failure associated with deletion of the insulin-like growth factor I gene. *N Engl J Med* 335:1363-1367
6. Walenkamp MJ, Karperien M, Pereira AM, Hilhorst-Hofstee Y, van Doorn J., Chen JW, Mohan S, Denley A, Forbes B, van Duyvenvoorde HA, van Thiel SW, Sluimers CA, Bax JJ, de Laat JA, Breuning MB, Romijn JA, Wit JM 2005 Homozygous and heterozygous expression of a novel insulin-like growth factor-I mutation. *J Clin Endocrinol Metab* 90:2855-2864
7. Bonapace G, Concolino D, Formicola S, Strisciuglio P 2003 A novel mutation in a patient with insulin-like growth factor 1 (IGF1) deficiency. *J Med Genet* 40:913-917
8. Coutinho DC, Coletta RR, Costa EM, Pachi PR, Boguszewski MC, Damiani D, Mendonca BB, Arnhold IJ, Jorge AA 2007 Polymorphisms identified in the upstream core polyadenylation signal of IGF1 gene exon 6 do not cause pre- and postnatal growth impairment. *J Clin Endocrinol Metab* 92:4889-4892
9. Netchine I, Azzi S, Houang M, Seurin D, Perin L, Ricort JM, Daubas C, Legay C, Mester J, Herich R, Godeau F, Le Bouc Y 2009 Partial primary deficiency of insulin-like growth factor (IGF)-I activity associated with IGF1 mutation demonstrates its critical role in growth and brain development. *J Clin Endocrinol Metab* 94:3913-3921
10. Woods KA 1998 *Molecular Mechanisms in Growth Hormone Insensitivity*. London: Paediatric

Endocrinology Section, Department of Endocrinology, St Bartholomew's Hospital London.

11. Walenkamp MJ, van der Kamp HJ, Pereira AM, Kant SG, van Duyvenvoorde HA, Kruihof MF, Breuning MH, Romijn JA, Karperien M, Wit JM 2006 A variable degree of intrauterine and postnatal growth retardation in a family with a missense mutation in the insulin-like growth factor I receptor. *J Clin Endocrinol Metab* 91:3062-3070
12. Miller SA, Dykes DD, Polesky HF 1988 A simple salting out procedure for extracting DNA from human nucleated cells. *Nucleic Acids Res* 16:1215
13. Gijsbers AC, Bijlsma EK, Weiss MM, Bakker E, Breuning MH, Hoffer MJ, Ruivenkamp CA 2008 A 400kb duplication, 2.4Mb triplication and 130kb duplication of 9q34.3 in a patient with severe mental retardation. *Eur J Med Genet* 51:479-487
14. Kulharya AS, Flannery DB, Norris K, Lovell C, Levy B, Velagaleti GV 2008 Fine mapping of breakpoints in two unrelated patients with rare overlapping interstitial deletions of 9q with mild dysmorphic features. *Am J Med Genet A* 146A:2234-2241
15. Niewenweg R, Smit ML, Walenkamp MJ, Wit JM 2003 Adult height corrected for shrinking and secular trend. *Ann Hum Biol* 30:563-569
16. van Wieringen JC, Wafelbakker F, Verbrugge HP, de Haas JH 1971 Growth diagrams 1965 the Netherlands. Leiden/Groningen, The Netherlands: Nederlands Instituut voor Praeventieve Geneeskunde/Wolters Noordhoff.
17. Ester WA, van Duyvenvoorde HA, de Wit CC, Broekman AJ, Ruivenkamp CA, Govaerts LC, Wit JM, Hokken-Koelega AC, Losekoot M 2009 Two short children born small for gestational age with insulin-like growth factor 1 receptor haploinsufficiency illustrate the heterogeneity of its phenotype. *J Clin Endocrinol Metab* 94:4717-4727
18. Kappeler L, De Magalhaes FC, Dupont J, Leneuve P, Cervera P, Perin L, Loudes C, Blaise A, Klein R, Epelbaum J, Le BY, Holzenberger M 2008 Brain IGF-1 receptors control mammalian growth and lifespan through a neuroendocrine mechanism. *PLoS Biol* 6:e254
19. Denley A, Wang CC, McNeil KA, Walenkamp MJ, van DH, Wit JM, Wallace JC, Norton RS, Karperien M, Forbes BE 2005 Structural and functional characteristics of the Val44Met insulin-like growth factor I missense mutation: correlation with effects on growth and development. *Mol Endocrinol* 19:711-721

Supplemental Data

Methods

Biochemical measurements

Plasma levels of IGF-I, IGF-II, IGFBP-1, -2, -3, -4 and -6 were determined as described previously (1). ALS was measured by a commercially available ELISA (Diagnostics Systems Laboratories, Inc., Webster, TX). With the exception of IGFBP-1 for adults older than 24 years, smoothed references based on the LMS method were available for all parameters allowing conversion of patient data to SDS values (1). For the adult members of the family plasma IGFBP-1 concentrations after an overnight fast were compared with a reference group of 6 healthy adult controls. Levels of insulin were determined in serum, obtained after an overnight fast, by a semi-automatic luminescence method (Immulite 1000; Siemens Medical Solutions Diagnostics, Los Angeles, CA).

Molecular studies with genomic DNA of the family members

Genomic DNA was isolated from whole blood according to the salting out procedure described by Miller et al (2). All exons of *IGF1* (GenBank accession number NM_000618) were PCR amplified and sequenced as described previously (1). The various primer sequences are available upon request.

For the analysis of single-nucleotide polymorphisms (SNPs), the Affymetrix GeneChip human mapping 262K *NspI* array (Affymetrix, Santa Clara, CA) was used. This SNP array is capable of genotyping approximately 262,000 SNPs, with a ~12 kb resolution. The assay was performed according to the manufacturer's protocol, beginning with 250 ng DNA. Detection of copy number changes was performed using Copy Number Analyser for GeneChip (CNAG) version 2.0 (www.genome.umin.jp/), using a reference set of minimal 5 and maximal 10 control DNAs (3;4).

Supplemental Figure 1

Growth curves of the index cases. The dots represent height measurements, the squares represent bone age measurements, and GH treatment is indicated below the curves. The growth curves of index cases III-1 and III-2 are shown in panels A and B, respectively.

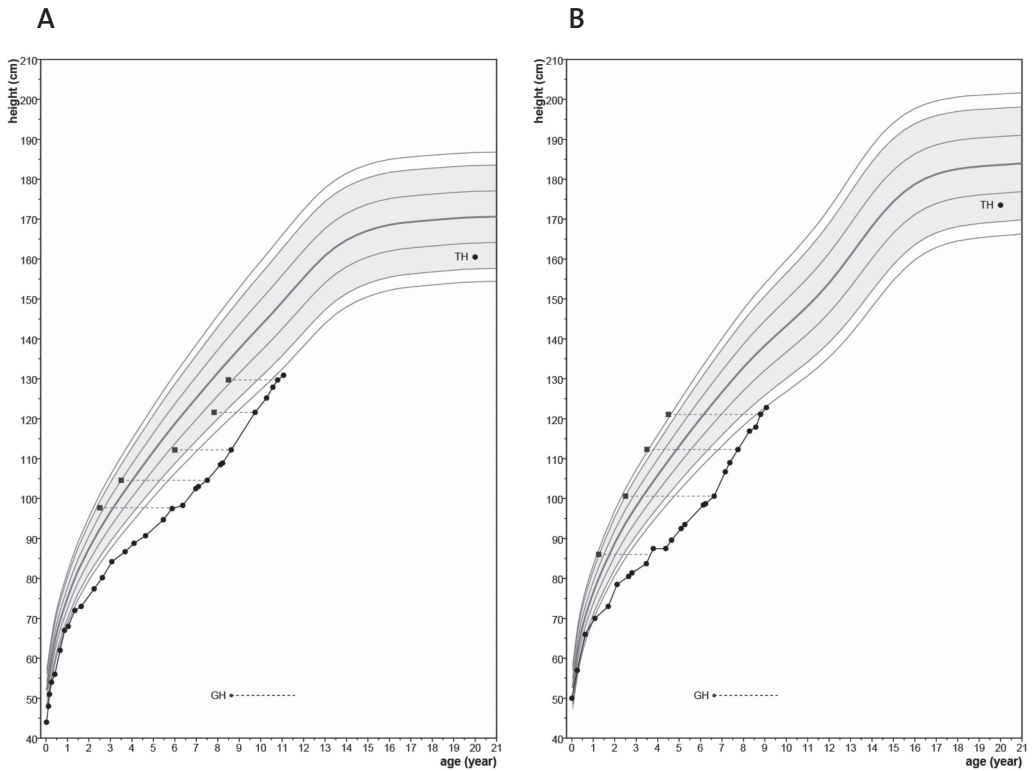

Reference List

1. Walenkamp MJ, Karperien M, Pereira AM, Hillhorst-Hofstee Y, van Doorn J, Chen JW, Mohan S, Denley A, Forbes B, van Duyvenvoorde HA, van Thiel SW, Sluimers CA, Bax JJ, de Laat JA, Breuning MB, Romijn JA, Wit JM 2005 Homozygous and heterozygous expression of a novel insulin-like growth factor-I mutation. *J Clin Endocrinol Metab* 90:2855-2864
2. Miller SA, Dykes DD, Polesky HF 1988 A simple salting out procedure for extracting DNA from human nucleated cells. *Nucleic Acids Res* 16:1215
3. Gijsbers AC, Bijlsma EK, Weiss MM, Bakker E, Breuning MH, Hoffer MJ, Ruivenkamp CA 2008 A 400kb duplication, 2.4Mb triplication and 130kb duplication of 9q34.3 in a patient with severe mental retardation. *Eur J Med Genet* 51:479-487
4. Kulharya AS, Flannery DB, Norris K, Lovell C, Levy B, Velagaleti GV 2008 Fine mapping of breakpoints in two unrelated patients with rare overlapping interstitial deletions of 9q with mild dysmorphic features. *Am J Med Genet A* 146A:2234-2241

