



Universiteit
Leiden
The Netherlands

Roentgen stereophotogrammetric analysis to study dynamics and migration of stent grafts

Koning, O.H.J.

Citation

Koning, O. H. J. (2009, June 25). *Roentgen stereophotogrammetric analysis to study dynamics and migration of stent grafts*. Retrieved from <https://hdl.handle.net/1887/13870>

Version: Corrected Publisher's Version

License: [Licence agreement concerning inclusion of doctoral thesis in the Institutional Repository of the University of Leiden](#)

Downloaded from: <https://hdl.handle.net/1887/13870>

Note: To cite this publication please use the final published version (if applicable).

CHAPTER

6

**Accurate Roentgen Stereophotogrammetric
Analysis of stent-graft migration using a
single aortic reference marker**

Olivier H.J. Koning
Eric H. Garling
Jan-Willem Hinnen
Martijn Holleman
Jaap F. Hamming
Edward R. Valstar
and J. Hajo van Bockel

Submitted

Abstract

Purpose: To assess the accuracy of detection of stent-graft migration with RSA using one single aortic reference marker instead of a cluster of several markers, as is currently standard in clinical RSA.

Methods: A model of a stentgraft was positioned in an aortic model that was connected to an artificial circulation with a physiological flow and pressure profile. A similar model of a stent-graft was positioned in the thoracic aorta of two pigs. Stent-graft migration was simulated in these in-vitro and in-vivo models. The amount of migration was determined using standard RSA with multiple aortic reference markers as well as with RSA using only one aortic reference marker (1-ref-RSA). RSA measurements with the circulation switched off were used as the reference standard to determine stent-graft migration in the in-vitro model. The measurement error of 1-ref-RSA was determined during pulsatile circulation in the in-vitro model. In-vivo, the results of RSA stent-graft migration measurement using a single reference marker and a standard cluster of reference markers were compared.

Results: The mean measurement error \pm SD of standard RSA during pulsatile circulation in-vitro was -0.5 ± 0.16 mm. Using 1-ref-RSA, the mean measurement error in-vitro was -0.73 ± 0.12 mm. In-vivo, the standard deviation of all measurements by standard RSA was 0.33mm as compared to the mean value of the corresponding group of migration measurements. 1-ref-RSA had a pooled mean error of 0.17 ± 0.65 mm as compared to standard RSA in-vivo.

Conclusion: Roentgen Stereophotogrammetric analysis with a single aortic reference marker enables very accurate detection of stent-graft migration.

Introduction

Stentgraft migration still occurs in spite of major improvement in stentgraft design over the past decade. Migration constitutes a potentially lethal complication after endovascular aneurysm repair (EVAR).¹⁻⁵ The current gold standard for detection of this phenomenon is contrast enhanced CT imaging.⁶ However, contrast enhanced CT has several disadvantages of which nephrotoxic contrast, high radiation dose and logistical burden are most important. Furthermore, the high cost of this investigation renders EVAR less cost effective.⁷ If the aneurysm size decreases during follow-up with ultrasound, migration and stentgraft integrity are the key points of interest in EVAR surveillance.

Roentgen stereophotogrammetric analysis (RSA) is a method that measures prosthesis migration relative to reference markers in the body (Figure 1).⁸⁻¹¹ RSA has proven to be highly accurate in clinical detection of prosthesis micro-motion after joint replacement surgery.^{12,13} It also demonstrated to be feasible and highly accurate in several stent-graft migration studies in-vitro and in-vivo.^{8,9,14} Furthermore, RSA is cheap, relatively simple and can also be used to detect stent fractures. Consequently, it has the potential to become the new gold standard for stentgraft migration detection.

RSA requires markers to perform position measurements and detect migration during follow up.⁸⁻¹¹ The most important disadvantage of RSA is that a reference marker is required that is attached to the aortic wall.^{8,9,14} This marker is used to determine position change, or migration, of the graft and will have to be inserted during the EVAR procedure. An enhanced version of the Anson Refix® Nitinol endovascular clip (Lombard Medical, Didcot, United Kingdom), an endovascular stapler device to secure a stent-graft to the aortic wall, might be used for this purpose.^{9,14} The design of the marker is currently under investigation at our institution.^{9,14}

An important question that has remained unanswered is how many markers are needed for accurate detection of axial stent-graft migration. At least three non linear placed markers are required in surveillance after joint replacement surgery.¹⁰ Using only one marker minimizes the additional risk and cost of the procedure. However, reducing the number of reference markers may diminish the accuracy of RSA measurement of axial migration of a stent-graft.

To assess the accuracy of detection of stent-graft migration with RSA using one single aortic reference marker instead of a cluster of reference markers as is currently standard in clinical RSA, we performed in-vivo and in-vitro experiments comparing these different reference points.

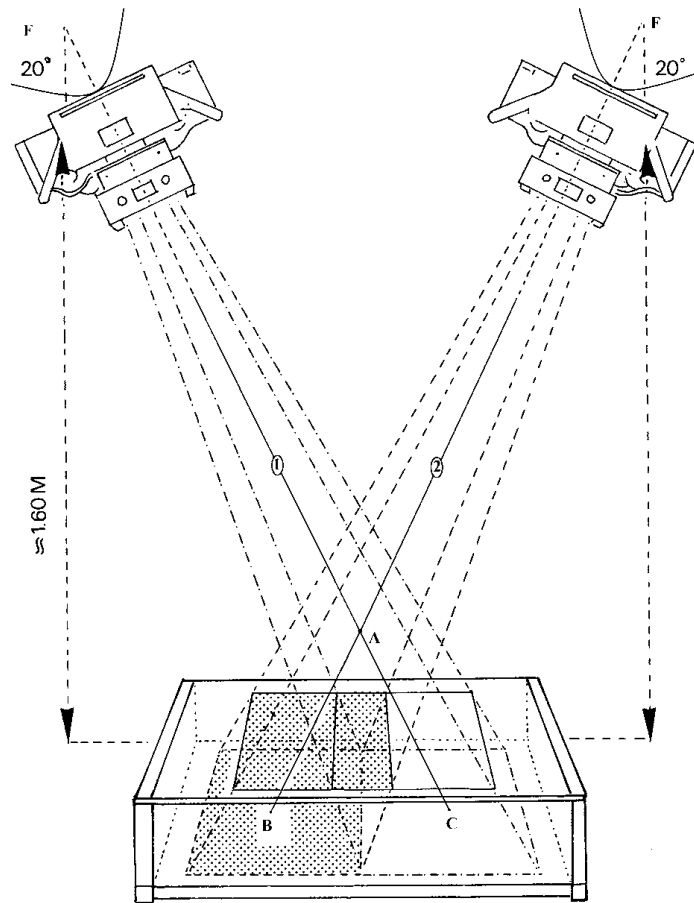

Figure 1. Schematic drawing of the RSA technique. Two standard hospital X-ray tubes (F) are used, in combination with two standard X-ray films or flat panel detectors placed directly under a calibration box that is positioned under the patient. The projection of the calibration box markers on the film is used to reconstruct the position of the Roentgen foci (F) and their relation to the two X-ray films. Graft marker A gives projections B and C on the films. With known focus position, projection lines 1 and 2 can be reconstructed; Calculating the intersection of lines 1 and 2 in space gives the position of A.

Methods

Pulsatile Aortic Model With Stent-Graft

A pulsatile flow model was developed to simulate migration of a stent-graft in the pulsating aorta.^{9,15} A human cadaver spine was obtained from the anatomical department and used according to the standard consent procedures of our Institutional Review Board. A fresh specimen of a pig thoracic aorta was attached to the cadaver spine, replacing the cadaveric aorta. The spine, including the surrounding soft tissues, was conserved in a solution of formaldehyde, ethanol, glycerin, and phenol (Figure 2).⁹ The model was placed in an Acrylic box, topped off with water to simulate soft tissue.



Figure 2. Model of the fresh pig aorta fixed to a human cadaver spine, complete with soft tissue. Three clusters of *aortic reference markers* are attached to the adventitia (arrows).

The perfusate of this artificial circulation was starch solution with the same viscosity as blood. To generate pulsatility, the model was connected to an artificial circulation set at 70 beats per minute with a 75 mL/s flow rate, which produced a physiological flow and pressure profile.^{9,15} The pulsatility resulted in a luminal diameter change from 20.0 to 21.5 mm, as recorded in M-mode ultrasound with a 7.5-MHz linear array probe (ProSound SSD-5500; ALOKA, Tokyo, Japan). This diameter change was induced to simulate aortic diameter changes measured in vivo.¹⁶⁻¹⁸

A Gianturco stent (Cook, Bjaeverskov, Denmark) was placed inside the aorta by endovascular technique. A stent rather than a stent-graft was used to model migration since radiological imaging techniques use the stents of the stent-graft for analysis. Furthermore, deleting the fabric from the model facilitated the induction of migration. The stent could be “migrated” along the aorta by pulling on monofilament fishing wire (Spro, Vianen, The Netherlands), which was attached to each side of the stent. To prevent unintended migration, the fishing wire was fixed to the box during the measurements.

For RSA analysis, markers were added at the cranial and caudal corners of the stent (i.e., *stent-graft markers*), and reference markers were attached to the aorta (i.e., *aortic markers*). The *aortic markers* consisted of three clusters of 1mm diameter tantalum markers glued to the aortic adventitia with Histoacryl (B. Braun Aesculap, Tuttlingen, Germany). These markers are also used in standard clinical RSA in joint replacement surgery (Figure 2). The aortic marker closest to the stent in the initial position / image was used for RSA analysis with one single reference marker (1-ref-RSA).

Three stent-graft positions were analyzed with RSA: the initial or reference position and 2 migrations. The stent-graft was migrated caudally under visual control provided by an image intensifier (Philips BV300 plus; Philips Medical Systems Europe, The Netherlands).

Since RSA is proven to be highly accurate in a static environment, RSA of the model without pulsatile circulation was used as the reference standard to determine actual stent-graft migration.⁸⁻¹¹ Five RSA images of the reference position and 3 images of each stent-graft position after migration were acquired. These results could later be compared to standard RSA and 1-ref-RSA with pulsatile circulation in the model, to determine the measurement error of the 2 techniques. The migration was assessed using cross-table analysis, comparing each of the 5 reference images to all 3 follow-up images, producing 15 measurements per migration.⁹

To determine the influence of pulsatility on RSA and 1-ref-RSA migration measurement, 11 RSA images were acquired of each stent-graft position at a random point in the pulsatile cycle. Migration was determined by cross-table analysis, comparing each of the 11 reference images to all 11 follow-up images, resulting in 121 measurements per migration or 121 possible clinical combinations of RSA images per migration. These images were assessed using all aortic reference markers ("standard" RSA) as well as one single reference marker (1-ref-RSA).

Animal Model With Stent-Graft

Two 100 Kg female pigs were used. The Institutional Review Board for animal experimentation approved the study and the animals were cared for in compliance with the national guidelines for animal experiments. After general anesthesia, the pulse rate was kept at approximately 90 per minute. Thoraco-laparotomy was performed exposing the thoracic and infrarenal aorta. Heparine was continuously administered. A Dacron 8mm tube graft (Gelsoft Plus, Vascutek, Inchinnan, UK) was attached to the infrarenal aorta as a conduit for vascular access.¹⁴

A Gianturco stent as described above was placed inside the thoracic aorta via endovascular technique. The thoracic aorta was chosen for placement as it has the largest available aortic diameter, resembling the human situation as much as possible. Migration was induced under visual control as described above, the fishing wire was positioned as a "body floss" through the left carotid artery and the conduit. Eight tantalum reference markers (with a diameter of 1 mm) were glued to the adventitia of the thoracic aorta using Histoacryl® (B.Braun Aesculap, Tuttlingen, Germany), the *aortic markers*. The aortic marker closest to the stent in the initial position / image was used for 1-ref-RSA analysis.

In the first animal, two stentgraft positions were analyzed: the initial or reference position and one migration. In the second animal, five stentgraft positions were analyzed: the initial or reference position and four migrations.

For each stent-graft position RSA imaging was performed.¹⁴ To simulate the in-vivo human situation and the influence of pulsatile motion on migration measurement by RSA and 1-ref-RSA, 5 RSA images were acquired of the reference position and 9 images of each stentgraft position after migration. The RSA images were acquired at a random point in the cycle of pulsatile circulation. Migration was assessed using cross-table analysis, comparing each of the 5 reference images to all 9 follow-up images. This resulted in 45 measurements per migration, resembling the 45 possible clinical combinations of RSA images. These images were assessed using all aortic reference markers ("standard" RSA) as well as only one reference marker (1-ref-RSA). To summarize the standard-RSA results, we pooled the data to determine the variance of the method. This was done by calculating the mean migration per group of 45 measurements. Afterwards, this value was subtracted from every single measurement in the same group, thereby calculating the variance of the standard-RSA measurement. This enabled calculation of the standard deviation and range of deviation of all standard-RSA measurements (n=225). The measurement error of 1-ref-RSA was determined by comparing each 1-ref-RSA observation to the corresponding mean value of migration measured by standard-RSA.

RSA imaging technique

We used two manually synchronized standard mobile Roentgen tubes to acquire the RSA images (Philips Practix 2000, Philips Medical Systems Europe, The Netherlands) (Figure 1). The exposure settings used were: 110 kV / 8.5 mAs, resulting in an exposure time of 78 ms for the in-vitro model and 125 kV / 15mAs, resulting in an exposure time of 160 ms for the animal studies.^{9,14}

After digitizing the films, image postprocessing was done on a personal computer with the help of special RSA software (Model Based RSA software, MEDIS Specials BV, Leiden, The Netherlands).^{8-11,14} The RSA images were randomly numbered and the reviewer was blinded for the distance of migration induced.

Using RSA, it is possible to calculate the distance between two (groups of) markers inside the body. Migration is determined by comparing an initial, reference RSA image to the follow up RSA image. The technique was previously described in more detail.⁸⁻¹¹

In RSA analysis, the relative positions of markers do not change in absence of migration. Any change in relative position indicates movement between the markers. Positioning of the

model, animal, or the patient, is not critical as the calibration box will facilitate the calculation of marker coordinates each time an RSA image is taken.

Results

In-vitro

The actual migration of the stent in the model as determined by standard RSA in a non pulsatile situation was $7.00 \pm 0.02\text{mm}$ ($n=15$) for the first migration; the second migration was $13.90 \pm 0.03\text{mm}$ ($n=15$).⁹

In the pulsatile situation standard RSA registered a migration of $6.50 \pm 0.08\text{mm}$ for the first, and $13.4 \pm 0.21\text{mm}$ for the second migration ($n=121$), the pooled measurement error was $-0.50 \pm 0.16\text{mm}$.⁹

According to 1-ref-RSA, the first migration in the pulsatile situation was $6.17 \pm 0.08\text{mm}$ ($n=121$). For the second migration 1-ref-RSA determined a mean migration of $13.28 \pm 0.08\text{mm}$ ($n=121$). The pooled measurement error of all migration measurements by 1-ref-RSA was $-0.73 \pm 0.12\text{mm}$. A box plot of the measurements is shown in Figure 3.

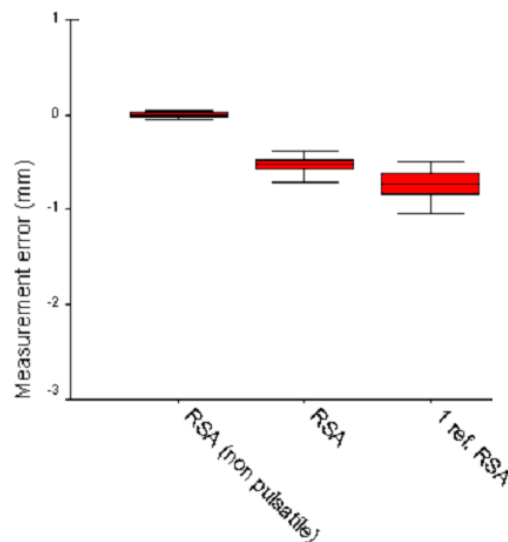

Figure 3. Boxplot of RSA migration detection in an in-vitro pulsatile model. X-axis: Standard of reference is RSA in the model without pulsatile circulation (RSA (non pulsatile)). RSA represents measurement error with three clusters of aortic reference markers. 1-ref-RSA represents measurement error with a single aortic reference marker. Box plot represents mean, 25th and 75th percentile and range.

In-vivo

Standard RSA measured a migration of $8.15 \pm 0.39\text{mm}$ for the migration in the first pig, migration 1-4 in the second pig were $6.59 \pm 0.23\text{mm}$, $10.74 \pm 0.36\text{mm}$, $15.03 \pm 0.26\text{mm}$ and $16.62 \pm 0.35\text{mm}$, respectively. The standard deviation of all measurements by RSA was 0.33mm as compared to the mean value of the corresponding group of migrations ($n=225$).¹⁴

The results of 1-ref-RSA were $9.09 \pm 0.68\text{mm}$ for the migration in the first pig and $6.42 \pm 0.84\text{mm}$, $9.95 \pm 0.31\text{mm}$, $14.73 \pm 0.15\text{mm}$ and $16.51 \pm 0.17\text{mm}$ for the migrations in the second pig, respectively. 1-ref-RSA had a pooled mean error of $0.17 \pm 0.65\text{mm}$ as compared to standard RSA.

Discussion

For the detection of stentgraft migration, the accuracy of RSA using only one single reference marker is slightly less accurate compared to standard, multiple reference markers. The in-vitro and in-vivo measurement errors of standard RSA as well as of RSA using one single reference marker appear to be well below 1mm, a difference that is clinically very acceptable and compares favorably with other techniques to determination stentgraft migration.^{8,9,14,20}

Reduction of the number of reference markers to only one single aortic reference marker for RSA surveillance of stent-graft migration appears to be feasible.

RSA requires a reference marker to measure a change in position. This reference marker is best attached to the aortic wall, close to the stent-graft.^{9,19} As discussed previously, a bony reference marker like the lumbar spine, or an artificial marker attached to the spine, is not useful because of the significant cyclic motion of the aorta-stent-graft complex relative to the lumbar spine.^{8,17,18,21} This cyclic motion will induce a cyclic error in measurement when bony reference markers are used, adding to the measurement error of RSA itself. Furthermore, it is difficult to accurately reproduce bony reference markers in a clinical setting. The stentgraft markers that are used to position the graft during surgical placement can be used for RSA-detection of the graft. However, it is important to be able to identify the different markers either through asymmetric placement on the graft or by specific marker characteristics. If this is not the case, symmetrical marker configurations will result in measurement errors due to erroneous identification and consequent position calculation of the marker by the software.

In orthopedic surgery, a cluster of at least three non linear placed tantalum markers are used to detect prosthesis micro-motion. Using this configuration enables accurate quantification of micro-motion in three dimensions, including rotational micro-motion. Using less than three markers eliminates the possibility of rotational motion measurement. Other forms of

motion are detectable using only one reference marker. The issue of interest in surveillance after EVAR is to detect stentgraft migration along the vessel wall. Rotation inside the vessel is of less importance for long term follow-up, and migration outside the vessel has not been reported. Therefore, on theoretical grounds, one single marker to detect axial migration could be sufficient. Our data show that the accuracy of RSA using a single reference marker is not significantly hampered for clinical use. Therefore, it appears that one single aortic reference marker is sufficient for stent-graft migration surveillance after endovascular aneurysm repair. Design, safety and positioning of the aortic reference marker are subject to further study at our institution.^{9,14}

Conclusion

Roentgen Stereophotogrammetric analysis with a single aortic reference marker enables very accurate detection of stent-graft migration.

Acknowledgement

We would like to acknowledge the help of M. Boonekamp, Department of Fine Mechanics, and A.A.H. van Immerseel, Department of Anatomy and Embryology, LUMC, for their assistance in building the in-vitro model.

References

1. Fransen GA, Vallabhaneni SR Sr, van Marrewijk CJ, Laheij RJ, Harris PL, Buth J; EUROSTAR Rupture of infra-renal aortic aneurysm after endovascular repair: a series from EUROSTAR registry. *Eur J Vasc Endovasc Surg*. 2003;26(5):487-93.
2. van Herwaarden, Joost A., van de Pavoordt, Eric D.W.M., Waasdorp, Evert J., Albert Vos, Jan, ThC. Overtoom, Tim, Kelder, Johannes C., Moll, Frans L., de Vries, Jean-Paul P.M. Long-Term Single-Center Results with Aneurx Endografts for Endovascular Abdominal Aortic Aneurysm Repair. *J Endovasc Ther*. 2007;14(3):307-317.
3. Greenberg RK, Chuter TA, Sternbergh WC 3rd, Fearnot NE; Zenith Investigators. Zenith AAA endovascular graft: intermediate-term results of the US multicenter trial. *J Vasc Surg*. 2004;39(6):1209-18.
4. Sun Z. Three-Dimensional Visualization of Suprarenal Aortic Stent-Grafts: Evaluation of Migration in Midterm Follow-up. *J Endovasc Ther*. 2006;13(1):85-93.
5. Torsello G, Posada N, Florek HJ, Horsch S, Kortmann H, Luska G, Scharrer-Pamler R, Schmiedt W, Umscheid T, Wozniak G; Talent AAA Retrospective Longterm Study Group Long-term outcome after Talent endograft implantation for aneurysms of the abdominal aorta: a multicenter retrospective study. *J Vasc Surg*. 2006;43(2):277-84
6. Wolf YG, Hill BR, Lee WA, et al. Eccentric stent graft compression: an indicator of insecure proximal fixation of aortic stent graft. *J Vasc Surg*. 2001;33:481-487.
7. Prinssen M, Buskens E, de Jong Seca, et al. Cost-effectiveness of endovascular versus conventional abdominal aortic aneurysm repair at one year. Results of a randomized trial. In: Prinssen M, ed. DREAM. Oud-Beijerland, The Netherlands: As BV; 2005:89-103.
8. Koning OH, Oudegeest OR, Valstar ER, Garling EH, van der Linden E, Hinnen JW, et al. Roentgen Stereophotogrammetric Analysis: an accurate tool to assess endovascular stentgraft migration. *J Endovasc Ther*. 2006;13:468-475
9. Koning OH, Garling EH, Hinnen JW, Kroft LJ, van der Linden E, Hamming JF, et al. Accurate detection of stentgraft migration in a pulsatile aorta using Roentgen Stereophotogrammetric Analysis. *J Endovasc Ther*. 2007;14(1):30-8.
10. Valstar ER. Digital roentgen stereophotogrammetry. Development, validation, and clinical application. Thesis, Leiden University. Den Haag, The Netherlands: Pasmans BV, 2001.
11. Vrooman HA, Valstar ER, Brand GJ, Admiraal DR, Rozing PM, Reiber JH. Fast and accurate automated measurements in digitized stereophotogrammetric radiographs. *J Biomech*. 1998;31:491-498.
12. Ryd L, Albrektsson BE, Carlsson L. F. Dansgard F, Herberts P, Lindstrand A, Regner L, and S. Toksvig-Larsen. Roentgen stereophotogrammetric analysis as a predictor of mechanical loosening of knee prostheses. *J Bone Joint Surg Br*. 1995;77:377-383.
13. Kärrholm J, Gill RH, Valstar ER. The history and future of radiostereometric analysis. *Clin Orthop Relat Res*. 2006 Jul;448:10-21.
14. Koning OH, Hinnen JW, Garling EH, Kroft LJ, van der Linden E, Hamming JF, et al. Roentgen Stereophotogrammetric Analysis to detect stentgraft migration in an animal model. Submitted for publication.
15. Hinnen JW, Visser MJ, van Bockel JH. Aneurysm sac pressure monitoring: effect of technique on interpretation of measurements. *Eur J Vasc Endovasc Surg*. 2005;29:233-238.
16. Stefanadis C, Dernellis J, Vlachopoulos C, et al. Aortic function in arterial hypertension determined by pressure-diameter relation: effects of diltiazem. *Circulation*. 1997;96:1853-1858.
17. Flora HS, Woodhouse N, Robson S, et al. Micromovements at the aortic aneurysm neck measured during open surgery with closerange photogrammetry: implications for aortic endografts. *J Endovasc Ther*. 2001;8:511-520.
18. Verhagen HJ, Teutelink A, Olree M, et al. Dynamic CTA for cutting edge AAA imaging: insights into aortic distensibility and movement with possible consequences for endograft sizing and stent design [Abstract]. *J Endovasc Ther*. 2005;12(suppl I):I-45.
19. Spoor CW, Veldpaus FE. Rigid body motion calculated from spatial co-ordinates of markers. *J Biomech*. 1980;13:391-393.
20. Hodgson R, McWilliams RG, Simpson A, et al. Migration versus apparent migration: importance of errors due to positioning variation in plain radiographic follow-up of aortic stent-grafts. *J Endovasc Ther*. 2003;10:902-910.
21. Vos AW, Wisselink W, Marcus JT, et al. Cine MRI assessment of aortic aneurysm dynamics before and after endovascular repair. *J Endovasc Ther*. 2003;10:433-439.

