



Universiteit  
Leiden  
The Netherlands

## **The research-teaching nexus in the sciences : scientific research dispositions and teaching practice**

Rijst, R.M. van der

### **Citation**

Rijst, R. M. van der. (2009, September 23). *The research-teaching nexus in the sciences : scientific research dispositions and teaching practice*. ICLON PhD Dissertation Series. Leiden. Retrieved from <https://hdl.handle.net/1887/14011>

Version: Corrected Publisher's Version

License: [Licence agreement concerning inclusion of doctoral thesis in the Institutional Repository of the University of Leiden](#)

Downloaded from: <https://hdl.handle.net/1887/14011>

**Note:** To cite this publication please use the final published version (if applicable).



**Chapter 4**

**Speech act theory as an instrument to capture  
university science teachers' discourse**



## 4. Speech act theory as an instrument to capture university science teachers' discourse<sup>3</sup>

The findings of studies on classroom discourse suggest that teachers' speech influences student learning. Although university teachers have diverse ways of lecturing, not many have a broad speech act repertoire. Patterns of 12 university science teachers' speech acts sequences were examined. Teachers with similar patterns were clustered, and associations with the methods of instruction and approaches to teaching were analysed. University teachers, whose approaches to teaching showed a high emphasis on student learning, used many directive speech acts such as questions and instructions. Teachers, who focused on transmitting ideas, used more assertive acts such as giving information and predictions. The presented framework can be applied as a window into teachers' speech act repertoires.

---

<sup>3</sup> This chapter has been submitted in an adapted form as:  
Van der Rijst, R.M., Visser-Wijnveen, G.J., Verloop, N., & Van Driel, J.H. *Speech act theory as an instrument to capture university science teachers' discourse*.

### **4.1 Introduction**

The findings of studies on classroom discourse suggest that teachers' speech has a persistent influence on students' learning and on their perceptions of the learning environment (cf. Rogers, Malancharuvil-Berkes, Mosley, Hui, & Joseph, 2005; Roth & Roychoudhury, 1994; Scott & Mortimer, 2006; Walshaw & Anthony, 2008). Academic staff at higher education institutes, and especially at research universities, professionally develop multiple scholarships, including the scholarship of development and the scholarship of teaching (Boyer, 1990; Healey, 2000; Trigwell, Martin, Benjamin, & Prosser, 2000). Many issues are relevant to the professional development of a university teacher in the scholarship of teaching, such as knowledge of student learning, knowledge of assessment, and knowledge of method of instructions. Knowledge of teachers' speech acts, as an element of knowledge of classroom discourse, also belongs to university teachers' knowledge base of teaching (Verloop et al., 2001). Teaching about scientific research, its methods, processes, and products, is an important content element of university courses. University teachers have many different ways of starting a discourse or monologue about research (cf. Elsen et al., 2009), but not many teachers are aware of their own speech act repertoire. For example, a science teacher may instruct students about what they should or should not do when working in a laboratory. Another teacher may describe how a research study is normally conducted in a laboratory. Both teachers might utter similar words, but convey a distinct message. Often, teachers do not explicitly select a particular way of addressing the students, but use a single personal style for uttering propositions during course meetings. A broad speech act repertoire can be helpful to motivate diverse students and to stimulate the multiple intelligences and learning styles of students. The aim of this study was twofold: first, to identify patterns in teachers' speech acts during courses, and second, to unravel associations between university teachers' speech acts, their approaches, and the methods of instruction. This study is relevant to teachers and teacher educators at higher education institutes who work on strengthening the scholarship of teaching and learning and for the improvement of teachers' speech act repertoires as an element of their knowledge base of teaching.

#### ***4.1.1 Discourse analysis and speech act theory***

Analysis of speech acts is one of the several forms of discourse analysis used to improve our understanding of issues in learning and instruction (e.g., Huisman, 2006; Karasavvidis, Pieters, & Plomp, 2000; Rogers et al., 2005; Roth & Roychoudhury, 1994; Saarinen, 2008). Speech act theory was first developed by

Austin (1962), and later by Searle (1969), as a part of the philosophy of language which was concerned not with what is *said*, but with what is *meant* by a particular expression (Bach & Harnish, 1979). Austin (1962) and Searle (1969) developed the idea that the meaning of a word is its use in language, into speech act theory. In their view, language is more than simply the transmission of information. Each lingual expression or utterance has a particular intent and, therefore, has an illocutionary point. The illocutionary point of a speech act refers to the communicative intention which is included in the act. The illocutionary point of an act is often indicated by performative verbs, such as to inform, to claim, to state, to demand, or to advise. Although these verbs may occur in specific speech acts, this is not a requirement. The speech act with the intention of demanding something, for example, can be expressed by saying, 'I hereby demand that you do this exercise', but also by saying 'Do this exercise' or 'Finish the exercise, please'. Performative verbs are indicators of the illocutionary point of the acts, but not necessary elements in these speech acts. Examples of other illocutionary indicators are the position of the verb, intonation, and gesture (Roth & Lawless, 2002). Note that these illocutionary indicators are not always to be found in transcriptions of spoken language. From the theories of speech acts, five main speech act types based on the purpose of the act can be distinguished: acts with assertive, commissive, declarative, directive, and expressive points (Austin, 1962; Bach & Harnish, 1979; Searle, 1969). An assertive act, described by some authors as a constative act, expresses the speaker's belief and intention that the hearer forms a similar belief. Examples of performative verbs describing assertive speech acts are the following: to inform, to reflect, to dispute, or to predict. Commissive acts express the speaker's intention and belief that his utterance obligates himself or herself to do something, and are accompanied by verbs, such as to promise, to offer, or to guarantee. When a speaker utters a declarative speech act, which some authors call effectives or verdicts, the utterance changes a state of affairs, such as when a vicar states, 'I declare you man and wife' or when the prime minister states, 'I hereby veto this bill.' Directive speech acts express the speaker's intention that the hearer takes action. Directive acts are, therefore, accompanied by verbs, such as to question, to ask, to advise, or to instruct. Expressive acts, or acknowledgements, express the speaker's feelings regarding the hearer, through verbs, such as to greet, to accept, to apologize, or to thank. Thus, expressive acts articulate an emotional state of the speaker towards the hearer. In educational contexts, speech acts with declarative purposes are expected to occur only in very specific situations, such as graduation ceremonies, and not often during the day-to-day course meetings.

### **4.1.2 Methods of instruction**

University teachers can select different methods of instruction for their courses. Most university courses can be broadly divided into three types of instruction: lectures, seminars, and practicals. This categorization is rather abstract. Within each type, sub-divisions are possible; for example, during the first course meeting of a practical, the teacher might first give a lecture about the content of the research assignments. Or during a typical lecture course a teacher might ask the students to reflect on the topic through discussing some issues with their peers. In each method of instruction the teacher has a distinct role. During a lecture, the teacher has the role of the 'expert', during a practical the teacher has the role of a 'guide', and during a seminar the teacher is more or less a 'discussion leader'. Teachers behave differently in different roles, and, therefore, it is plausible that teachers' speech acts diverge between methods of instruction and teacher roles. In this study, we examined associations between teachers' speech acts and methods of instruction.

### **4.1.3 Approaches to teaching**

In the field of higher education, many studies have been reported on approaches to teaching (cf. Gregory & Jones, in press; Kember 1997; Kember & Kwan, 2002; Prosser et al., 1994; Postareff & Lindblom-Ylänne, 2008; Stes, Gijbels, & Van Petegem, 2008). The discussion about approaches to teaching is more multifaceted than presented here; we present only those aspects which are necessary to this study. The Approaches to Teaching Inventory (ATI; Prosser et al., 1994) is frequently used to examine teachers' approaches in higher education, and its items are composed from the idea that teachers have both an intention and a strategy when teaching university courses. Different teaching intentions were identified, including conceptual-change and information-transmission intentions. Teaching strategies were also identified, including teacher-focused and student-focused strategies. Factor analysis showed that the ATI distinguishes two types of approaches to teaching: conceptual-change/student-focused (CCSF) and information-transmission/teacher-focused (ITTF). Stes, De Maeyer, and Van Petegem (2008) recently translated the ATI and tested its validity in the context of higher education in Flanders, Belgium. The results indicate that the instrument is rather context-dependent. Stes, De Maeyer, and Van Petegem (2008), therefore, recommend adapting the formulation of the items to the context in which the questionnaire is used. Furthermore, Martin, Prosser, Trigwell, Ramsden, and Benjamin (2000) showed that university teachers' approaches in a *specific* course are consistent with their teaching practices. Teachers' approaches, however, can

be inconsistent with their teaching practices when the *general* approaches of university teachers are considered (cf. Murray & McDonald, 1997). Therefore, regarding *specific* teaching situations, we expected a high correspondence between teachers' approaches and the actual teaching practice. In their review study of research on teachers' beliefs and practices, Kane, Sandretto, and Heath (2002) present the risk of telling half the story when only paying attention to the teachers' perspective. They call for studies in which associations are drawn between observations of teaching practice and what teachers say about their teaching: it is important to be aware that teachers' self reports about their teaching might not be as close to their actual teaching practice as is often assumed. In the present study, this was done by relating teachers' speech acts to teachers' approaches to teaching.

#### **4.1.4 Research questions**

In this study, we focused on teachers' speech acts as an element of their teaching practice, and investigated associations between teachers' speech acts, their approaches to teaching, and the methods of instruction of the courses. The two leading research questions in this study were *what typical sequences can be recognised in individual teachers' speech during course meetings, and are teachers' typical speech act sequences associated with their approaches to teaching and the method of instruction used during science courses?*

## **4.2 Methods**

### **4.2.1 Sample and research context**

The participants were 12 university science teachers, 2 female and 10 male, of the Faculty of Science of Leiden University. All participants volunteered to participate in a larger research project which focused on the research-teaching nexus in the sciences. The participants ranged in position from assistant professor to full professor, and taught courses in various sub-disciplines. In one way or another, all courses of the participants were research intensive (Elsen et al., 2009). Furthermore, a variety of methods of instruction was present in the courses. These methods of instruction were categorised into three main groups: lectures, seminars, and practicals. These methods of instruction are characterised by differences in typical group size: large, medium, and small groups, respectively. In this sample, lectures had typical group sizes of 15 students or more, seminars had group sizes between 7 and 15 students, and the group size during practicals was fewer than 7 students. The amount of time students were to spend on each course ranged between 28 and 196 hours of study load.



### **4.2.2 Procedure**

During the autumn and winter of 2007, the participants' classes were audio-tape recorded using a tie-clip microphone. The first 15 minutes of the course meetings were recorded and transcribed verbatim, with transcription accuracy confirmed by the author. After the final meetings, the teachers were presented with the Dutch version of the Approach to Teaching Inventory (ATI; Stes, De Maeyer, & Van Petegem, 2008).

### **4.2.3 Analysis of teachers' speech acts**

Teachers' speech acts were analysed using categories retrieved from the literature. Speech act analysis is basically a qualitative method, in which particular speech acts are analysed individually. The individual utterances are classified and their semantic relationships taken into consideration to categorize their intention. In this study, the method was also used in a more quantitative fashion through the determination of the frequency of the speech act types and the calculation of typical speech act sequences of each participant. The analysis procedure can be divided into three phases: (1) development of a codebook, (2) determination of the inter-rater reliability, (3) establishment of agreement. These phases are similar to classic content analysis or related qualitative methodologies in which a pre-developed coding scheme based on findings of previous studies are used (Krippendorff, 1980; Ryan & Bernard, 2000). We explain each phase of the analysis procedure in some detail.

Phase 1, development of a codebook: Speech act types and matching performative verbs were collected from the literature on the philosophy of language (Austin, 1962; Searle, 1969). Five main speech act types are distinguished in the literature, namely, assertive, commissive, declarative, directive, and expressive speech acts. Especially in educational contexts, also utterances with an evaluative intent occur. For example, in explaining to students the most effective way to solve a problem, a teacher may say, "That's a good way to approach the problem" or "You are doing very well, now." Therefore, evaluative acts were categorised as specific codes. Expressive speech acts articulate an emotional state of the speaker, while evaluative acts articulate the speakers' normative values. The six primary codes were discussed by the research team and applied to a sample of transcripts, resulting in a preliminary codebook. Each single sentence uttered was coded. Compound sentences were separated. This resulted in a total of 1870 fragments from 12 teachers. Based on the initial reading of the fragments, several sub-categories were proposed and negotiated by the research team. As a result, three types of directive speech acts were

distinguished: question, advice, and instruct. The assertive acts were sub-categorised into inform, predict, and reflect. Student talk was coded as 'student speech acts.' These student speech acts were not divided into separate speech act codes, because the focus of this study was on teachers' utterances. The codebook was applied to a sample of four transcripts and adapted according to the results. Demarcation rules were described to distinguish between categories. Table 4.1 depicts the categories of speech acts with illustrative quotes. Phase 2, determination of the inter-rater reliability: An independent rater was consulted to verify if the codebook could be used by people other than members of the research team. First, a sample of four transcripts was coded independently by the independent rater and the author. The codes, the demarcation rules, and all differences in assigned codes were discussed. The demarcation rules were modified according to the results of the discussion. Finally, the inter-rater reliability was determined based on the codes assigned by both raters to a sample of 4 new transcripts. Inter-rater agreement on the level of the sub-categories was Cohen's Kappa .69; on the level of the main categories, Cohen's Kappa was .73. Student talk was excluded from the calculation of inter-rater agreement, because no dissimilarities between raters could occur.

Phase 3, establishment of agreement: Agreement on the codes of all transcripts was established by the independent rater and the author following negotiation of the differences between codes. The dissimilarity between raters could be related to at least two points. First, most of the dissimilarities were found within assertive speech acts, thus between assertive-inform, assertive-predict, and assertive-retrospect. Second, some fragments had dual illocutionary points, such as a directive act with an evaluative point. For example, the utterance 'Don't do that foolish thing' includes both an evaluative and an instructional point. This sometimes occurred with evaluative illocutionary points which were incorporated within assertive or directive acts.

#### **4.2.4 Post-course administration of the ATI**

The language and vocabulary of the ATI version of Stes, De Maeyer, and Van Petegem (2008) were adapted to the Dutch higher education context. The questionnaire consisted of 22 items, which could be sub-divided into two main scales, conceptual-change/student-focus (CCSF) and information-transmission/teacher-focused (ITTF). We followed the proposal of Stes, De Maeyer, and Van Petegem (2008) for the item distribution in the scales. Cronbach's alpha reliabilities of the two scales for the sample in this study were

.98 (CCSF) and .87 (ITTF). For all participants, the scores on the two scales CCSF and ITTF were calculated.

*Table 4.1 Categories and explanations of illocutionary points of teachers' speech acts*

Categories of speech acts	Explanation of illocutionary point of speech act
Assertive acts	Assertive speech acts express the speaker's belief and his intention or desire that the hearer have or form a similar belief. An utterance that asserts a thing that can be judged as true or false. The illocutionary point of an assertive act focuses on persuading the hearer to form a parallel belief. Assertive acts are divided into three sub-categories: 1) Inform: speaker articulates assertions about factual situations or phenomena at this moment. 2) Predict: speaker talks about expectations for future situations, or asserts consequences or predictions. 3) Reflect: speaker formulates assertions about past situations, and reflects in a non-normative way.
Commissive acts	Commissive speech acts express the speaker's intention and belief that his utterance obligates him to do something. The illocutionary point of a commissive act focuses on the behaviour and cognition of the speaker.
Declarative acts	Declarative speech acts are judgments that by convention have official, binding import in the context of the institution in which they occur. For example, the speaker utters a thing as part of his function or position. The effect of a declarative act changes an institutional state of affairs. The illocutionary point of a directive act focuses on change of a current situation.
Directive acts	Directive speech acts express the speaker's attitude toward some prospective action by the hearer and his intention that his utterance, or the attitude it expresses, be taken as a reason for the hearer's action. The illocutionary point of a directive act focuses on the hearer's behaviour. Directive acts are divided into three sub-categories: 1) Question: speaker formulates questions. In transcripts often, but not always, indicated with a question mark. 2) Instruct: speaker gives instructions to the hearer. 3) Advise: speaker formulates a recommendation.
Evaluative acts	Evaluative speech acts express the speaker's perceived evaluation of a thing. This expressed value is clearly the main point of the utterance; thus, the act comprises a normative load. Speech acts including words such as 'better', 'more effective', or 'nicer' are often evaluative. The illocutionary point of an evaluative act focuses on communication of a perceived value or norm of the speaker.
Expressive acts	Expressive speech acts express the speaker's feelings regarding the hearer or, where the utterance is clearly perfunctory or formal, the speaker's intention that his utterance satisfies a social expectation of expression of certain feelings and his belief that it does so. The illocutionary point of an expressive act focuses on communication of an emotional state of the speaker.

**4.2.5 Analysis of typical speech act sequences**

To enable recognition of characteristic patterns in teachers' utterances, participants were grouped with respect to similarities in their speech acts. Similarities were then identified within these groups with respect to method of instruction and approach to teaching. Frequencies of speech acts only give information about the occurrence of the individual acts, and not about successive acts. Information about successive utterances would improve our understanding of teachers' speech acts during course meetings. Therefore, not only were the frequencies determined, also the transitional frequencies for four successive speech acts were calculated. These transitional frequencies are called lag sequential acts. A lag  $n$  speech act is the  $n$ th speech act that precedes or follows a particular act. Figure 4.1 visually presents the sequence of four successive speech acts and the lag 1, lag 2, and lag 3 acts. Lag 1 acts ( $X_1X_2$ ,  $X_2X_3$ , and  $X_3X_4$ ) are those acts which directly follow a particular act; lag 2 acts ( $X_1X_3$  and  $X_2X_4$ ) are the second succeeding acts; and the lag 3 act ( $X_1X_4$ ) is the third succeeding act. To determine transitional frequencies, SPSS syntax for analysing lag-sequential categorical data (O'Conner, 1999) was used.

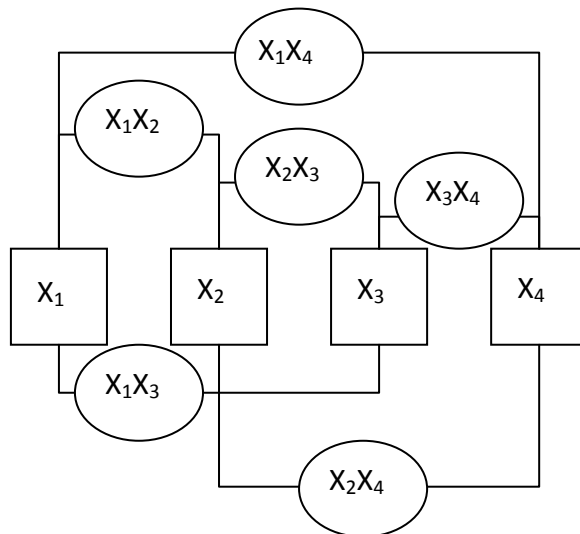

*Figure 4.1 Sequence of successive speech acts with lag 1, lag 2, and lag 3 successors*

First, the frequencies were determined of the original arrays of teachers' speech acts. Second, frequencies and transitional frequencies were calculated for reduced arrays in which similar successive acts were deleted. Similar acts were

deleted in order to create arrays in which successive acts were always different from previous acts. This was done to identify changes in types of speech acts in the lag sequential analysis. To identify the typical sequence of speech acts during the classroom activities of the participants, which consisted of four consecutive codes, a quantitative measure for typical sequences was developed. This measure consisted of weighted probabilities of the frequencies and the transitional frequencies, namely, (1) the weighted probability of the frequencies of the four individual codes ( $X_i$ ) with respect to the total number of codes ( $Total$ ), (2) the weighted probability of the frequencies of the three lag 1 sequences ( $X_iX_{i+1}$ ), (3) the weighted probability of the frequencies of the two lag 2 sequences ( $X_iX_{i+2}$ ), and (4) the weighted probability of frequency of the lag 3 sequence ( $X_iX_{i+3}$ ).

$$TypicalSequence := \left( \frac{X_1 + X_2 + X_3 + X_4}{4 \cdot Total} \right) + \left( \frac{X_1X_2 + X_2X_3 + X_3X_4}{3 \cdot (Total - 1)} \right) + \left( \frac{X_1X_3 + X_2X_4}{2 \cdot (Total - 2)} \right) + \left( \frac{X_1X_4}{(Total - 3)} \right) \quad (4.1)$$

$$(\Delta TypicalSequence)^2 = \left( \frac{1}{(Total)^2} \right) + \left( \frac{1}{(Total - 1)^2} \right) + \left( \frac{1}{(Total - 2)^2} \right) + \left( \frac{1}{(Total - 3)^2} \right) \quad (4.2)$$

The addition of these four elements resulted in a quantity which could be used to determine the most typical speech act sequence (see Formula 4.1). If  $Z = A + B$ , then the error in  $Z$  equals  $(\Delta Z)^2 = (\Delta A)^2 + (\Delta B)^2$ . Therefore, if we estimated the measurement errors in the subsequent frequencies on 1, then the standard errors in the typical sequences ( $\Delta TypicalSequence$ ) could be estimated as  $\frac{2}{Total}$  (see Formula 4.2 for exact error in typical sequence). The standard errors in the typical sequences were used as a criterion to determine the most typical sequences of the participants.

### 4.3 Results

#### 4.3.1 Teachers' speech acts

In total, more than half of teachers' speech acts were assertive speech acts (60%), roughly 20 percent were directive acts, and 8% consisted of evaluative acts. Five percent of teachers' speech acts consisted of commissive acts, and two percent were expressive acts. Only 10 percent were student speech acts. No declarative acts were found in this sample. Table 4.3 depicts the frequencies of the speech act types per participant before similar successive acts were deleted, and shows the

actual uttered acts of the participants during class. The names of the participants are fictitious to preserve anonymity. Assertive-inform speech acts were coded most often in the fragments; they made up 39% of the 1870 coded fragments. Table 4.2 depicts the speech act sequences which scored highest on the typical measure calculated using Formula 4.1.

*Table 4.2 Participants' typical speech act sequences*

Participant	Typical Speech act Sequence			
	X1	X2	X3	X4
Dr. Simon	Inform	Predict	Inform	Predict
	Question	Inform	Question	Inform
Dr. Paul	Inform	Question	Inform	Question
	Question	Student	Question	Student
Dr. Nathan	Question	Inform	Commissive	Inform
Dr. Susan	Instruct	Inform	Instruct	Inform
	Inform	Instruct	Inform	Instruct
Dr. Charles	Inform	Student	Inform	Student
	Inform	Question	Student	Inform
Dr. Adam	Inform	Evaluative	Inform	Evaluative
Dr. Edward	Reflect	Inform	Reflect	Inform
Dr. Adrian	Inform	Reflect	Inform	Reflect
	Reflect	Inform	Reflect	Inform
Dr. Carlos	Inform	Predict	Inform	Predict
Dr. Tanya	Inform	Evaluative	Inform	Evaluative
	Predict	Inform	Predict	Inform
Dr. Howard	Inform	Predict	Instruct	Inform
	Predict	Inform	Predict	Inform
Dr. Eliot	Inform	Predict	Inform	Predict
	Predict	Inform	Predict	Inform

Table 4.3 Frequencies of speech acts before similar successive acts were deleted

Participant	Sub-discipline	Total Number	Assertive			Directive			Evaluative	Commissive	Expressive	Student act
			Inform	Predict	Reflect	Question	Instruct	Advise				
Dr. Simon	Chem	174	114	17	8	18	5	3	5	1	0	
Dr. Paul	Chem	178	29	11	8	29	6	11	1	7	64	
Dr. Nathan	Astro	110	57	8	1	14	2	5	14	2	1	
Dr. Susan	Bio	125	31	17	23	2	24	5	1	8	3	
Dr. Charles	Compu	189	53	16	9	21	12	18	7	6	32	
Dr. Adam	Astro	148	63	24	2	15	4	15	6	4	8	
Dr. Edward	Chem	103	21	23	26	4	1	7	4	2	10	
Dr. Adrian	Chem	285	111	21	29	32	13	22	16	6	24	
Dr. Carlos	Math	62	27	10	10	1	1	7	4	0	1	
Dr. Tanya	Bio	120	41	14	30	10	1	16	4	1	1	
Dr. Howard	Compu	176	60	27	15	8	21	9	12	3	4	
Dr. Eliot	Phys	200	126	26	6	11	0	11	14	2	2	
<b>Total</b>		<b>1870</b>	<b>733 (.39)</b>	<b>214 (.11)</b>	<b>167 (.09)</b>	<b>165 (.09)</b>	<b>90 (.05)</b>	<b>129 (.07)</b>	<b>88 (.05)</b>	<b>42 (.02)</b>	<b>150 (.08)</b>	

*Table 4.4 Lag frequencies and typical measure for participants' speech act sequences*

Participant	Total number of codes	Typical speech act sequence								Lag 1 frequencies			Lag 2 frequencies		Lag 3 frequencies	Typical Measure (S.E.)
		X1		X2		X3		X4		X1-X2	X2-X3	X3-X4	X1-X3	X2-X4	X1-X4	
		X1	X2	X2	X3	X3	X4	X4	X1	X2	X3	X4	X1	X2	X3	
Dr. Simon	97	41	17	41	17	41	17	41	17	13	10	13	27	3	11	0.70 (.02)
		16	41	16	41	16	41	16	41	11	13	11	4	27	12	0.71 (.02)
		41	16	41	16	41	16	41	16	13	11	13	27	4	10	0.69 (.02)
Dr. Paul	147	28	51	28	51	28	51	28	51	25	16	25	8	30	19	0.58 (.01)
Dr. Nathan	75	13	28	11	28	11	28	11	28	9	5	10	6	18	10	0.68 (.03)
Dr. Susan	84	16	21	16	21	16	21	16	21	6	5	6	5	11	6	0.46 (.02)
		21	16	21	16	21	16	21	16	5	6	5	11	5	4	0.43 (.02)
Dr. Charles	149	34	24	34	24	34	24	34	24	6	6	6	9	8	5	0.33 (.01)
		34	19	24	34	19	24	34	19	6	8	6	2	5	10	0.32 (.01)
Dr. Adam	100	34	14	34	14	34	14	34	14	12	9	12	21	7	10	0.60 (.02)
Dr. Edward	74	16	16	16	16	16	16	16	16	6	7	6	6	10	8	0.55 (.03)
Dr. Adrian	218	62	26	62	26	62	26	62	26	11	12	11	23	6	9	0.37 (.01)
		26	62	26	62	26	62	26	62	12	11	12	6	23	9	0.37 (.01)
Dr. Carlos	37	14	7	14	7	14	7	14	7	5	5	5	6	2	4	0.65 (.06)
Dr. Tanya	73	22	13	22	13	22	13	22	13	7	3	7	10	5	7	0.52 (.03)
		12	22	12	22	12	22	12	22	8	6	8	4	10	4	0.49 (.03)
Dr. Howard	134	37	20	37	20	37	20	37	20	8	6	10	7	7	9	0.39 (.02)
		20	37	20	37	20	37	20	37	6	8	6	3	13	6	0.37 (.02)
Dr. Eliot	110	45	22	45	22	45	22	45	22	19	14	19	31	7	10	0.73 (.02)
		22	45	22	45	22	45	22	45	14	19	14	7	31	10	0.72 (.01)



**4.3.2 Typical speech act sequences**

Table 4.4 shows the frequencies of all variables in Formula 4.1 and 4.2. Some teachers have more than one sequence with similar typical measures, or at least within the standard error. This means that those speech act sequences are equally typical of the speech acts during that particular class. Often the orders of two individual speech acts change within the sequences, for example, in the sequences of Dr. Eliot, Dr. Adrian, and Dr. Susan. However, some speech acts which equal typical measures are differently organised. For example, the sequences of Dr. Charles show a sequence with directive-question acts and a sequence with student speech acts. Both sequences of Dr. Charles are, intuitively, related, in the sense that the questions are directed to students, and student speech acts in the typical sequence reflect a classroom discourse with teacher-student dialogue. In this perspective it is interesting to note that the directive-questions in the sequence of Dr. Paul can be interpreted as different acts from the directive-question acts in the sequence of Dr. Charles. The directive-question acts of Dr. Charles are not typically followed by student answers, but by assertive-inform acts by the teacher. These directive-questions could, for example, have been posed to stimulate student thinking more than to stimulate student responses. Thus, in speech act sequences the interpretation of acts depends on the consecutive order of the acts. Generally, assertive-inform is part of the sequences, except in the typical sequence of Dr. Paul, which consists of directive-question and student acts.

**4.3.3 Groups of typical speech act sequences**

Two groups of typical speech act sequences can be broadly recognised in the data in university courses: sequences with assertive acts and sequences with directive acts. The assertive speech act sequences can be sub-divided into two groups, one with assertive-predict acts and the other with assertive-reflect acts. The directive sequence group can be divided into a group with directive-question acts and a group with directive-instruct speech acts. The typical speech act sequences of Dr. Charles and Dr. Adam are special cases, in the sense that neither sequence can be incorporated into the two larger groups. Dr. Adam typically uses evaluative acts, and Dr. Charles typically involves students during his teaching. Table 4.5 shows the typical sequence groups. Dr. Nathan's typical sequence is the only sequence which consists of commissive speech acts, such as promises or offers. Dr. Nathan also uses directive-question acts and, therefore, has been assigned to the directive-question group. Furthermore, the speech act sequences of Dr. Simon draw attention because one of the sequences belongs to the assertive-predict

group, while the other two belong to the directive group. We position Dr. Simon in the directive–question group, because two of his typical sequences consist of question acts. In the discussion we present explanations as to why some teachers have more typical sequences than other teachers.

To illustrate the differences between the groups of typical speech act sequences, fragments from participants' course meetings are presented. For presentation purposes, original fragments in Dutch were translated by the author. The first fragment illustrates a typical assertive speech act sequence. This fragment, with assertive-reflect acts, was taken from the course transcripts of Dr. Adrian.

Dr. Adrian: In the last meeting we discussed the benefits of alternative splicing, a single gene produces multiple products. (Assertive-reflect)

Dr. Adrian: We will talk again about transposons, cell-typical structures of proteins, which we've already seen. (Assertive-reflect)

Dr. Adrian: And, ladies and gentleman, here we are again, are you male or female? (Directive-question)

Dr. Adrian: We often have this kind of conversation in this room, that's not my fault, it's part of the course content. (Assertive-reflect)

Dr. Adrian: Yesterday, we talked about why female genes are more often used in offspring than male genes. (Assertive-reflect)

Dr. Adrian: And after the meeting, one of the men came up to me and said, "Sir, are we going to get some bonus points in the final test, because we got so depressed during your course?" (Assertive-reflect)

This sequence illustrates how assertive-reflect acts are used in lecture-type courses. The next fragment illustrates the use of evaluative acts during a course meeting; it was selected from the transcripts of Dr. Tanya.

Dr. Tanya: Actually, almost nobody had noticed it. (Assertive-reflect)

Dr. Tanya: It was so subtle; the horse went on tipping until he got the sign. (Assertive-reflect)

Dr. Tanya: This, now, is known as the Hans effect. (Assertive-inform)

Dr. Tanya: That really is the well-known name of these kinds of phenomena. (Assertive-inform)

Dr. Tanya: So, Hans could not count, but very remarkable it was. (Evaluative act)

Dr. Tanya: And that's what many forget, it was a remarkably clever horse, because it completed the task in a very innovative way. (Assertive-inform)

Dr. Tanya: He likely didn't have any clue whatsoever, (assertive-reflect)

Dr. Tanya: But it was an extremely good pupil. (Evaluative act)

Dr. Tanya: He knew that in many different tasks and many different contexts, and so on, that he just had to pay close attention to what his boss did (Assertive-reflect)

Dr. Tanya: And he learned in an associative way what the sign was for when to stop, when his boss looked happy and when he was going to receive his award. (Assertive-reflect)

Dr. Tanya: It really is a magnificent example in two ways. (Expressive act)

Dr. Tanya: One is how to pay close attention when training animals. (Assertive-inform)

Dr. Tanya: Very close, actually, because you almost never know what you do (Evaluative act)

Dr. Tanya: And when you have all your procedures, the people who train the animals do not know what the actual goal is, if that is possible, often not. (Assertive-predict)

Throughout Dr. Tanya's course meeting, evaluative acts and assertive-reflect acts are iterated using assertive-inform acts. Furthermore, Dr. Tanya, like Dr. Adam, typically uses evaluative acts. For example, "That is a good question!" or "Generally, that is good for the observations". These evaluative speech acts can be broadly divided into two categories, first, sharing of teachers' opinions about course content or methodologies and, second, evaluating the learning processes of students. Although the previous examples illustrate an element habitually present in teachers' daily talk, namely, assertive speech acts, directive speech acts also play an important role in teachers' discourse. The following fragment illustrates directive acts selected from the transcripts of Dr. Susan.

Dr. Susan: So, I mean, as long as we have enough, check and see how many seawater plates there are before you do anything. (Directive-instruct)

Dr. Susan: Because everybody needs to make at least one fresh plate for next week, but if there are more than that, then try other temperatures if you can. (Directive-instruct)

Dr. Susan: Sometimes they won't. (Assertive-inform)

Dr. Susan: Most bugs got a plus or minus 15 degrees around their optimum. (Assertive-inform)

Dr. Susan: But some of these bugs seem to grow quite happily from room temperature down to almost freezing. (Assertive-inform)

Dr. Susan: So check this and see, because it would be nice to have some bugs growing at room temperature or at 18 degrees, just so we can pack them all in. (Directive-instruct)

Dr. Susan: Otherwise we have to turn the 18 degrees stove down I think. (Assertive-predict)

Dr. Susan: Also, now that I have a brand new 18-degree shaker, it would be nice to be able to use it. (Assertive-predict)

Dr. Susan clearly provides students with helpful instructions for getting through the practical laboratory assignments. She gives instructions and explains to the students some of the consequences if the instructions are not followed. During practicals these strict instructions are often necessary, not only with regard to completion of the assignments, but also in relation to the strict safety regulations when working with living organisms ('bugs'). These instructions are important during laboratory classes, but questions are also often posed by teachers. The following fragment illustrates a speech act sequence during a lecture-type course in which the teacher asks questions of the students. This fragment with directive-question comes from Dr. Simon.

Dr. Simon: Eventually, you need an equal amount of E2's and E3's as you have proteins to eliminate. (Assertive-inform)

Dr. Simon: Do you get this? (Directive-question)

Dr. Simon: Okay, to what do E2's and E3's bond? (Directive-question)

Dr. Simon: The two larger ones ..., the categories are hydrophobic patches in proteins. (Assertive-inform)

Dr. Simon: Hydrophobic means that they do not like water. (Assertive-inform)

Dr. Simon: That's what my colleague probably explained in the last meeting; if not, then please pay attention. (Assertive-reflect)

Dr. Simon: Hydrophobic means that it does not like water. (Assertive-inform)

Dr. Simon: The protein molecule is the driving force behind protein folding.  
(Assertive-inform)

Dr. Simon: There are electrostatic charges in a protein molecule related the hydrophobic places in the amino acid. (Assertive-inform)

Dr. Simon: What is the protein going to do? (Directive-question)

Dr. Simon: Just chemistry, the electrostatic charges are going outside, because they want to have contact with the water and the hydrophobic part will turn inside (Assertive-inform)

Dr. Simon: The protein folds into a certain form. (Assertive-inform)

Dr. Simon: That is why the protein folds in another order of charges  
(Assertive-inform)

Clearly, the questions in Dr. Simon's monologue were posed as a rhetorical tool to stimulate students cognitively and to motivate students to listen. Directive-question speech acts, naturally, can also be used differently, as questions in order to elicit direct student responses.

#### **4.3.4 Characteristics of the typical speech act groups**

In Table 4.5, the method of instructions, divided into three types, lecture, seminars, and practicals, are presented alongside the typical speech act groups. Among other things, Table 4.5 shows that teachers use directive speech acts most often during practicals, while they use more assertive acts during lectures. The typical speech act of Dr. Edward is an anomaly for this statement. The meetings in the particular phase of the practicals at the moment of tape-recording were more similar to lectures than were other meetings later in the course curriculum, in the sense that the teacher reflected on previous work and talked about what to do next. Therefore, it is conceivable that Dr. Edward used more assertive-reflect speech acts than he would have done in a different practical course meeting.

Table 4.5 also depicts the score of each participant on the two ATI scales conceptual-change/student-focused (CCSF) and information-transmission/teacher-focused (ITTF). On the whole, the overall means show that participants in this sample score slightly higher on the CCSF scale (3.58) than on the ITTF scale (3.08). The speech acts of participants with approaches high on the CCSF scale (Dr. Simon, 4.70; Dr. Paul, 4.30) both have typical sequences with directive and student acts. These participants often asked questions and encouraged students to react. The speech acts of the two participants with approaches to teaching high on the ITTF scale (Dr. Adrian, 4.73; Dr. Howard, 3.82) are both characterised by a combination of assertive-inform and assertive-predict in their typical sequences.

Dr. Susan scores high on ITTF scale (3.91), but she also scores high on the CCSF scale. Finally, Dr. Charles is remarkable with respect to his approach, because both his CCSF score and his ITTF score are rather low. This may be related to the method of instruction, a seminar, or it may be interpreted as showing that the respondent found few links between the ATI items and his particular course.

*Table 4.5 Distribution of the variables method of instruction and approach to teaching among speech act groups and participants*

Group	Participant	Method of instruction	Approaches to Teaching	
			CCSF	ITTF
Directive-question	Dr. Simon	Practical	4.70 (.48)	2.18 (.87)
Directive-question	Dr. Paul	Practical	4.30 (.68)	2.91 (1.30)
Directive-question	Dr. Nathan	Seminar	3.70 (.68)	3.18 (1.40)
Directive-instruct	Dr. Susan	Practical	4.00 (1.63)	3.91 (1.30)
Student	Dr. Charles	Seminar	2.20 (1.23)	2.45 (1.13)
Evaluative	Dr. Adam	Seminar	3.90 (1.29)	2.73 (1.27)
Assertive-reflect	Dr. Edward	Practical	3.80 (1.03)	3.00 (1.10)
Assertive-reflect	Dr. Adrian	Lecture	3.50 (1.18)	4.73 (.47)
Assertive-predict	Dr. Carlos	Lecture	4.10 (.74)	2.27 (.47)
Assertive-predict	Dr. Tanya	Lecture	3.60 (.84)	2.91 (1.45)
Assertive-predict	Dr. Howard	Seminar	2.70 (1.06)	3.82 (.87)
Assertive-predict	Dr. Eliot	Lecture	2.40 (1.51)	2.91 (1.22)
			<b>3.58 (.77)</b>	<b>3.08 (.74)</b>

## 4.4 Conclusions and discussion

### 4.4.1 Assertive and directive speech acts

To answer the first research question, regarding the characteristic patterns recognisable in teachers' speech acts, we clustered teachers into groups characterised by sequences with assertive acts and sequences with directive acts. The assertive-sequence group was sub-divided into two groups, typical sequences with assertive-reflect acts and typical sequences with assertive-predict acts. The directive-sequence group was sub-divided into sequences with questions and sequences with instructions. Below, we summarize the characteristic features of the typical speech act sequences of the participants, and turn to the second research question, about the associations between speech act groups, methods of instruction, and approaches to teaching.

Seven of the twelve teachers had more than one typical speech act sequence. Often these sequences were mirrored versions; however, sometimes two or more typical speech acts of a single teacher were qualitatively different.

This means that the different speech act sequences were typically present in the uttered arrays during the course meeting, which can be interpreted as showing that the particular teacher had a broad repertoire of speech acts. For example, Dr. Simon used two different typical speech act sequences in his course meetings, one with directive-question acts and the other with assertive-predict acts. Both sequences were equally typical during the course meetings. Thus, Dr. Simon gave information to students followed by questions of the students, as well as making predictions, such as stated in a speculative format (if-then). That these sequences had an equally high typical measure (see Table 4.4) shows that they were equally present during his course meeting, which represents the repertoire of speech acts used. In this way, the typical measure can illuminate the applied speech act repertoires of university teachers.

From the analysis of teachers' speech acts during university courses, we first observed that assertive-inform speech acts were most frequently present in the typical sequences. From this we conclude, with respect to the first research question, that speech acts in which the teacher has the intention to inform students are most often present in teachers' utterances. Whatever method of instruction or approach a teacher uses, he/she always inform students, for example, about course content or about assignments. Second, we conclude, with respect to the second research question, that during lectures teachers mostly used assertive speech acts, while during laboratory courses they more often used directive speech acts. During lectures teachers primarily explained course content, while during laboratory courses teachers more often gave students instructions on how to proceed with the inquiry. Finally, related to the second research question, we conclude that teachers who scored high on the CCSF approach more often used directive speech acts, such as questions or instructions, while teachers who scored high on the ITTF approach more often used assertive acts. It is plausible that teachers who put emphasis on conceptual change engage in dialogue with students more often than do teachers who put emphasis on information transmission.

### ***4.4.2 Limitations and suggestions for further research***

Although we did not focus on the content of the discourse between teachers and students in this study, it was possible to use the categorisation of speech acts developed for teachers to analyse the discourse during course meetings. The theoretical foundation and the possibility of empirically locating types of speech acts are the advantages of the categorisation presented in this study. However, some limitations should be noted. First, during the development of the speech

acts categorisation scheme, we noted that speech acts with an evaluative illocutionary point often seemed to co-occur in assertive or directive speech acts. This means that the category of evaluative speech act was not always clearly demarcated from other types of speech acts. Therefore, we suggest that, in future research using this method of speech act analysis, the use of evaluative acts should be re-evaluated as a distinct speech act category. When evaluative acts are disregarded, it might be expected that inter-rater reliabilities will increase. Second, we found associations between teachers' speech acts and the methods of instruction; however, teacher roles might be an underlying variable which explains teachers' variety in speech acts better than methods of instruction can explain. Further studies in which teacher roles are related to teachers' speech acts might give a better understanding of the discourse phenomena during university courses. Furthermore, we did not sub-divide student speech acts in this study. The presented method of speech act analysis provides us with a tool to analyse students' speech acts in combination with teachers' speech acts. Further research in which students' as well as teachers' speech acts are analysed will provide a better understanding of discourse between student and teacher in university courses. Finally, teachers' speech acts related to student understanding and students' perceptions of the learning environment are of interest to educational researchers in the field of learning and instruction.

The method of speech act analysis presented in this study can uncover teachers' speech act repertoires, and thus can be used in multiple ways in professional development programmes for teachers, or as a self-reflection tool in educational practice. Speech act theory provides teachers with a method to reflect on their own speech act repertoire, and with a framework to expand their repertoire. When university teachers and teacher trainers recognise that teachers' speech acts play a relevant role in educational practice in higher education, and that it is possible to expand one's speech act repertoire, teachers might become more inclined to work on the scholarship of teaching and learning, and their knowledge base of teaching (Verloop et al., 2001).



