



Universiteit
Leiden
The Netherlands

Agreement, Dominance and Doubling : the morphosyntax of DP
Schoorlemmer, E.

Citation

Schoorlemmer, E. (2009, September 3). *Agreement, Dominance and Doubling : the morphosyntax of DP*. LOT dissertation series. LOT, Utrecht. Retrieved from <https://hdl.handle.net/1887/13952>

Version: Not Applicable (or Unknown)

License: [Licence agreement concerning inclusion of doctoral thesis in the Institutional Repository of the University of Leiden](#)

Downloaded from: <https://hdl.handle.net/1887/13952>

Note: To cite this publication please use the final published version (if applicable).

Agreement, Dominance and Doubling
The morphosyntax of DP

Published by
LOT
Janskerkhof 13
3512 BL Utrecht
The Netherlands

phone: +31 30 253 6006
fax: +31 30 253 6406
email: GW_LOT@uu.nl
<http://www.lotschool.nl>

Cover illustration: *boom* by Erik Schoorlemmer

ISBN: 978-90-78328-94-0
NUR: 616

Copyright © 2009: Erik Schoorlemmer. All rights reserved.

Agreement, Dominance and Doubling
The morphosyntax of DP

PROEFSCHRIFT

ter verkrijging van
de graad van Doctor aan de Universiteit Leiden,
op gezag van Rector Magnificus prof. mr. P.F. van der Heijden,
volgens besluit van het College voor Promoties
te verdedigen op donderdag 3 september 2009
klokke 16.15 uur

door

Erik Schoorlemmer

geboren te Haarlem
in 1980

Promotiecommissie

Promotores: Prof. dr. J.E.C.V. Rooryck
Prof. dr. L.L. Cheng

Commissieleden: Prof. dr. D. Pesetsky (Massachusetts Institute of Technology)
Prof. dr. L.C.J. Barbiers (Meertens Instituut/Universiteit Utrecht)
Prof. dr. Y.A.O d'Hulst (Universität Osnabrück)
Prof. dr. R.A.G. d'Alessandro

Table of contents

TABLE OF CONTENTS	I
ACKNOWLEDGEMENTS	V
CHAPTER 1.....	1
INTRODUCTION.....	1
CHAPTER 2.....	5
THE GERMANIC DP: DERIVING DOUBLE DEFINITENESS	5
1. INTRODUCTION	5
2. THE C-COMMAND PARADOX.....	7
2.1. <i>Attributive vs. predicative adjectives: interpretation and inflection</i>	8
2.2. <i>The c-command paradox</i>	10
2.3. <i>Outline of the proposal</i>	13
3. THE PROPOSAL	15
3.1. <i>Theoretical background</i>	15
3.2. <i>Definite DPs without an adjective</i>	16
3.3. <i>Modified definite DPs</i>	19
3.3.1. <i>Adjunction of AP to DP</i>	20
3.3.2. <i>Internal merge of D</i>	23
3.3.3. <i>Interpretation at the CI-interface</i>	26
3.3.4. <i>Morphology</i>	28
3.3.5. <i>A note on Chain Reduction and the ordering of operations</i>	29
3.4. <i>Summary</i>	30
4. THE DISTRIBUTION OF DOUBLE DEFINITENESS	31
4.1. <i>Double definiteness without a prenominal adjective</i>	31
4.1.1. <i>DPs with numerals and weak quantifiers</i>	32
4.1.2. <i>The demonstrative use of the definite article</i>	34
4.2. <i>Definite DPs with adjectives, but without double definiteness</i>	37
4.2.1. <i>DPs with a non-suffixal D</i>	37
4.2.1.1. <i>Denna-type demonstratives</i>	38
4.2.1.2. <i>Prenominal possessors</i>	39
4.2.2. <i>Proper names</i>	42
4.2.3. <i>Nonreferential DPs</i>	46
4.3. <i>A note on relative clauses</i>	47
4.4. <i>Summary</i>	49
5. DEFINITENESS MARKING IN OTHER GERMANIC LANGUAGES.....	50
5.1. <i>German and Dutch</i>	52
5.2. <i>Danish</i>	54
5.3. <i>Modern Icelandic</i>	57
5.4. <i>Summary and predictions</i>	61
6. PREVIOUS ANALYSES OF DOUBLE DEFINITENESS	63
6.1. <i>Head movement accounts (Delsing 1993, Embick & Noyer 1997)</i>	63
6.2. <i>Problems for the head movement accounts</i>	65
6.3. <i>The phrasal movement approach (Julien 2002, 2003, 2005)</i>	67

6.4.	<i>Problems for the phrasal movement approach</i>	68
6.5.	<i>The lexicalist approach: Hankamer & Mikkelsen (2002, 2005)</i>	70
6.6.	<i>Problems for the lexical approach</i>	72
6.7.	<i>The phase-based account (Heck, Müller & Trommer 2007)</i>	72
6.8.	<i>Problems for the phase-based account</i>	74
6.9.	<i>Summary</i>	74
7.	CONCLUSION.....	75
CHAPTER 3.....		77
THE STRUCTURAL CONDITION ON AGREE.....		77
1.	INTRODUCTION.....	77
2.	C-COMMAND VS. DOMINANCE.....	79
2.1.	<i>A dominance requirement on Agree</i>	80
2.1.1.	Dominance and Bare Phrase structure.....	81
2.1.2.	Predictions of the dominance requirement.....	82
2.1.3.	Agree: BPS, spell-out and derivational syntax.....	84
2.1.3.1	Bare Phrase Structure and label sharing.....	84
2.1.3.2	The spell-out of Agree-relations.....	86
2.1.3.3	The Earliness Principle.....	87
2.1.4.	Summary.....	89
2.2.	<i>C-command</i>	90
2.2.1.	Chomsky (2000): two different structural conditions on Agree.....	90
2.2.2.	Predictions of the complement and the c-command requirement.....	93
2.3.	<i>Three candidates for the structural condition on Agree</i>	95
3.	CONFIGURATION 1: THE GOAL IN THE COMPLEMENT OF THE PROBE.....	97
4.	CONFIGURATION 2: GOAL IN SPEC PROBE.....	98
4.1.	<i>Person Agreement in Georgian (Rezac 2003, 2004)</i>	99
4.2.	<i>Conclusion</i>	103
5.	CONFIGURATION 3.....	103
5.1.	<i>Arguments in favor of dominance</i>	104
5.1.1.	Hungarian: predicative-attributive asymmetry.....	104
5.1.2.	The Swedish predicative-attributive asymmetry.....	106
5.1.3.	Intermediate conclusion.....	107
5.2.	<i>Arguments in favor of c-command</i>	108
5.2.1.	The Swedish predicative-attributive symmetry.....	108
5.2.2.	Romance: French.....	109
5.3.	<i>A deadlock</i>	110
6.	CONCLUSION.....	111
CHAPTER 4.....		113
STRONG AND WEAK ADJECTIVAL INFLECTION IN GERMANIC		113
1.	INTRODUCTION.....	113
2.	FEATURES, AGREE AND THE INTERFACES.....	115
2.1.	<i>The syntactic representation of features</i>	116
2.1.1.	Chomsky's (2001) attribute-value system.....	116
2.1.2.	An alternative: obligatory feature underspecification.....	120
2.1.3.	Morpho-driven feature representation.....	126

2.2.	<i>The theory of Agree</i>	129
2.3.	<i>The theory of Agree and the interfaces</i>	134
2.3.1.	Three scenarios for Probes	135
2.3.2.	Interface conditions.....	137
2.4.	<i>Summary</i>	142
3.	AGREEMENT ON ATTRIBUTIVE ADJECTIVES IN GERMANIC	142
3.1.	<i>Strong adjectival inflection: Indirect Agree</i>	143
3.2.	<i>Weak adjectival inflection: Indirect Agree is blocked</i>	147
3.3.	<i>Outlook</i>	151
4.	THE STRONG – WEAK DISTINCTION IN SWEDISH	151
4.1.	<i>The syntactic representation of gender and number in Swedish</i>	151
4.2.	<i>Swedish strong adjectival inflection</i>	154
4.2.1.	Strong adjectival inflection in articleless DPs	155
4.2.1.1	The syntactic derivation of Swedish articleless DPs	155
4.2.1.2	Illustration of the proposal for Swedish articleless DPs.....	156
4.2.1.3	VI-insertion rules for Swedish strong adjectival inflection.....	161
4.2.2.	Strong adjectival inflection in DPs with an indefinite article	163
4.3.	<i>Swedish weak adjectival inflection</i>	170
4.3.1.	Illustration of the proposal	170
4.3.2.	The weak adjectival paradigm	174
4.4.	<i>Conclusion</i>	176
5.	THE STRONG-WEAK DISTINCTION IN OTHER GERMANIC LANGUAGES.....	176
5.1.	<i>Norwegian</i>	176
5.2.	<i>Danish</i>	179
5.3.	<i>Dutch</i>	180
6.	A NOTE ON THE POSITION OF ADJECTIVES IN DEFINITE DPs	182
7.	CONCLUSION	183
CHAPTER 5.....		187
STRONG AND WEAK ADJECTIVAL INFLECTION IN GERMAN		187
1.	INTRODUCTION	187
2.	GERMAN ADJECTIVAL INFLECTION: THE DATA	187
3.	THE REPRESENTATION OF GENDER, NUMBER, AND CASE IN GERMAN	191
4.	STRONG ADJECTIVAL INFLECTION	199
5.	WEAK ADJECTIVAL INFLECTION	201
5.1.	<i>Singular</i>	203
5.1.1.	Gender neutralization.....	203
5.1.2.	The structural vs. inherent case distinction	209
5.1.3.	Dative and Genitive neutralization	216
5.2.	<i>Plural</i>	216
5.3.	<i>The complete weak paradigm: VI-rules</i>	219
5.4.	<i>Illustration of the account for German weak adjectival inflection</i>	223
5.4.1.	Singular neuter accusative DP	223
5.4.2.	Plural masculine genitive DP	229
5.5.	<i>A note on masculine singular accusative</i>	231
5.6.	<i>German weak adjectival inflection: summary</i>	235
6.	THE MIXED PARADIGM	237

7. CONCLUSION	240
CHAPTER 6.....	243
ROMANCE ADJECTIVAL AGREEMENT.....	243
THE DOMINANCE REQUIREMENT REVISITED.....	243
1. INTRODUCTION	243
2. THE SWEDISH ATTRIBUTIVE-PREDICATIVE AGREEMENT SYMMETRY	244
3. ADJECTIVAL AGREEMENT IN ROMANCE AND BEYOND	247
3.1. <i>The Romance predicative-attributive agreement symmetry.....</i>	<i>247</i>
3.2. <i>The adjunction site of attributive adjectives in Romance</i>	<i>249</i>
3.3. <i>The adjunction of attributive adjectives and word markers</i>	<i>252</i>
3.3.1. The lack of weak adjectival inflection in West Flemish	252
3.3.2. Word markers in Romance and West Flemish.....	254
3.3.3. The role of word markers in the grammar.....	258
3.3.4. Illustration of the account.....	263
3.3.5. A note on the relation between word markers and gender	266
3.4. <i>Back to the predicative/attributive adjectival agreement symmetry</i>	<i>269</i>
4. CONCLUSION: THE STRUCTURAL CONDITION ON AGREE IS THE DOMINANCE CONDITION	270
CHAPTER 7.....	273
CONCLUSION.....	273
REFERENCES.....	275
SAMENVATTING IN HET NEDERLANDS	283
CURRICULUM VITAE	291

Acknowledgements

A lot of people contributed to the research presented in this thesis. I am very grateful for all the suggestions, good advice, discussion, questions and other feedback I received over the past couple of years. I benefited greatly from it.

First, I would like to particularly thank those two individuals whose names are absent in this acknowledgements section according to the Leiden tradition. Without them, I would not be a linguist, leave alone have written a dissertation.

I would also like to thank David Pesetsky, Anikó Lipták, Sjef Barbiers and Yves d'Hulst for reading the entire manuscript and giving valuable comments.

A lot of people gave feedback on the research presented in this thesis at several occasions: Milan Rezac, Marjo van Koppen, Jeroen van Craenenbroeck, Liliane Haegeman, Riny Huijbregts, Hans Broekhuis, Gertjan Postma, Roberta d'Alessandro, Martin Salzmann, Mark de Vos, Norbert Corver, Guido Vanden Wijngaerd, Tarald Taraldsen, Peter Svenonius, Kristine Benzen, Anders Holmberg, Gereon Müller, Olaf Koeneman, Fred Weerman, Artemis Alexiadou, Frank Drijkoningen and Željko Bošković.

Special thanks go to Jenny Doetjes for her valuable suggestions concerning double definiteness. She also provided me on several occasions with good advice on linguistics, teaching and much more. I am extremely grateful for this.

During my time as a PhD-student, I first shared an office with Frank, then with Boya, then with Joanna and Luis, then only with Luis and finally with Margarita. I enjoyed sharing an office with all of them.

Special thanks goes to Gea Hakker of the LUCL office who knows to efficiently solve every practical problem in no time. I would also like to thank Claartje Levelt and Crit Cremers for being excellent teachers at the early stages of my career and more recently for being exceptional colleagues. Finally, I would like to thank my current and past colleagues at LUCL. Jenneke, Mika, Frank, Joanna, Boya, Marjo, Jeroen, Mark, Martin, Hilke, Stella, Boban, Nourredine, Luis, Leo, Kaca, Camelia, Tanja, Arlette, Annemie, Annemiek, Maarten van Leeuwen, Marijn, Kathrin, Monica, Linda, Felix, Mélanie, Barbara, Sita, Willemijn, Anikó, Marc, Jos, Maarten Hijzelendoorn, Leston, Rint, Assemakis, Birgit, Alice, Allison, Roland, Leontine, thank you all for making my time at LUCL such an enjoyable experience.

Some of these people I would like to thank separately. My career and that of Hilke have been running in parallel over the last 8 years, first as undergraduates in the linguistics department and then as PhD-students. I still regret the fact that I could not make it to Hilke's defense, but I am sure she did a magnificent job defending her thesis. I wish her all the best for the future. In the early stages of my career as a PhD-student, I had the luck of having Martin as a colleague. He is a good friend. I really enjoyed the long conversations I had with Tanja about all kinds of syntactic problems, but also about almost everything else (differences between Belgium and the Netherlands being a recurring theme). I hope that we will keep having these conversations in the future. It is a pity she cannot make it to the defense.

Outside of Leiden, I would like to thank the Brussels CRISP-team (Lobke, Marijke, Karen, Adrienne, Jeroen, Guido and Dany) for being friends and for almost

making me feel that I am associated with an additional linguistics department. I hope that we can continue to collaborate in the future (in some form or another).

My two *paranimfen*, Geert and Margarita, also deserve a special place in this acknowledgement section. They did a superb job in helping me prepare the defense day. It is great fun to share an office with Margarita. She has great stories to tell from time to time about her family and Bulgaria, but she can also work really hard and is amazingly efficient. Geert and I have been friends since high school. I hope that he will continue to pop in for dinner every couple of weeks or so.

I wouldn't be what I am now without my family and especially my parents. They have unfailingly supported me. Thank you!

The final thanks go to Nana and Plusje for making my life outside of linguistics interesting and so much fun. I can never thank you two enough for that! I hope to enjoy your wonderful company for many years to come.

Chapter 1

Introduction

In the Romance languages, attributive adjectives display agreement with the noun they modify. In the French examples in (1), the adjective *beau* ‘beautiful’ for instance agrees with the noun for gender.

- (1) a. *un beau bâtiment* [French]
a beautiful.MASC building.MASC
‘a beautiful building’
b. *une belle voiture*
a beautiful.FEM car.FEM
‘a beautiful car’

In the Germanic languages, attributive adjectives can also agree with the noun they modify. In Swedish indefinite DPs, adjectives display gender and number agreement, as shown in (2).

- (2) a. *en ung-Ø flicka* [Swedish]
a young-NONNEUTER.SG girl.NONNEUTER
‘a young girl’
b. *ett stor-t hus*
a big-NEUTER.SG house.NEUTER
‘a big house’

At first sight, agreement on Germanic attributive adjectives seems similar to that on their Romance counterparts. However, there is a crucial difference between the two language groups. Although they display full agreement in some contexts, like in (2), Germanic attributive adjectives display no agreement or only partial agreement in other contexts. In the definite counterparts of the Swedish DPs (2), the adjective does not display agreement with the noun. Instead, it takes an ending *-a* that does not reflect the number and gender features of the noun, as in (3).

- (3) a. *den ung-a flickan* [Swedish]
the young-A girl.NONNEUTER-the
‘the young girl’
b. *det stor-a hus-et*
the big-A house.NEUTER-the
‘the big house’

Since the inflection on the adjective in (3) does not signal any gender and number distinctions, it is often referred to as the weak adjectival inflection. Its counterpart in (2), which does express such distinctions, is often called strong adjectival inflection (see among others Grimm 1870; Sauerland 1996; Leu 2008; Roehrs 2009). In the Germanic languages, adjectival inflection thus displays a strong-weak distinction.

In the Romance languages, attributive adjectives always display full agreement with the noun they modify. Unlike in Germanic, there are no contexts in which they do not agree or only partially agree with the noun. Put differently, adjectival inflection in Romance lacks a strong-weak distinction. In the definite counterparts of the French examples in (1), the agreement on the adjective is identical to that in (1), as can be seen in (4).

- (4) a. *le beau bâtiment* [French]
 the beautiful.MASC building.MASC
 ‘the beautiful building’
 b. *la belle voiture*
 the beautiful.FEM car.FEM
 ‘the beautiful car’

In this thesis, I investigate these patterns of adjectival agreement in Romance and Germanic. I present a unified account of why Romance attributive adjectives always display agreement independent of the context in which they occur, while agreement on their Germanic counterparts is sensitive to the context in which the adjectives occur.

The main claim of this thesis is that agreement on attributive adjectives is never the result of a direct syntactic relation between the adjective and the noun. Instead, I propose that it is always licensed indirectly as the result of mediation by another element. The patterns of adjectival agreement are attributed to whether there is an element available to mediate between the adjective and the noun. For independently motivated reasons, such a mediating element is unavailable in Germanic in some contexts, but is available in others. This yields the distinction between strong and weak adjectival inflection in Germanic. In Romance, the syntax of the DP is such that there is always an element that mediates between the noun and the adjective. Hence, there is no strong-weak distinction in Romance.

In addition to giving an account for the patterns of adjectival agreement in Romance and Germanic, this thesis also has another, more theoretical, goal. This goal is to critically review some of the components of the theory of Agree, the syntactic licensing of agreement (among others Chomsky 2000, 2001; Frampton & Gutmann 2000; Rezac 2003; Pesetsky & Torrego 2004). I will argue that two of the components of the theory of Agree need to be revised. First, I argue that the configuration in which Agree can be established should not be formulated in terms of the c-command relation, as in Chomsky (2000, 2001), but that it should be defined in terms of the dominance relation. This yields two desirable results. First, a definition in terms of dominance has a greater empirical adequacy than one in terms of c-command. Second, such a definition entails a simplification, since dominance is a more primitive relation than c-command. The second component of the theory I propose to revise is the syntactic representation of morphosyntactic features. I will

show that the standard way of representing morphosyntactic features poses serious learnability problems for the L1 learner. I argue that these problems can be overcome by adopting a syntactic feature representation in which the morphological realization of features determines their syntactic representation. These two revisions to the theory of Agree and some other minor modifications eventually lead to a highly explicit theory of Agree that makes precise and fine-grained empirical predictions. This theory, in combination with independently needed analyses of the Romance and Germanic DP, predict in surprising detail the patterns of agreement displayed by Germanic and Romance attributive adjectives. In this way, the theoretical goal of this thesis, i.e. the refinement of the theory of Agree, and its more empirically oriented goal, explaining the Romance and Germanic patterns of adjectival agreement, are combined.

This thesis is organized as follows. Chapter 2 investigates the structure of the Germanic DP. The licensing of agreement depends on the syntactic configuration of the elements involved in the agreement (see among others Chomsky 1995, 2001, Rezac 2003, Baker 2008). In order to account for the patterns of agreement on attributive adjectives in Germanic, the syntactic structure of DP therefore needs to be established. Chapter 2 determines this structure by taking as a starting point definite DPs containing adjectives in Swedish, Norwegian, and Faroese. These DPs are different from their unmodified counterparts in the same languages as well as from modified and unmodified DPs in the other Germanic languages in the sense that they display a doubling of the definite article. This doubling is also known under the name double definiteness (see among others Delsing 1993, Julien 2005, Hankamer and Mikkelsen 2005). In the Swedish DP in (5), the freestanding definite article preceding the noun is doubled by a definite suffix on the noun.

- (5) *det stor-a hus-et* [Swedish]
 the big-A house.NEUTER-the
 ‘the big house’

I claim that this doubling is the result of internal merge of D triggered by the presence of the adjective. This internal merge creates a structure with two D-copies. In the morphological component of the grammar, both these copies are spelled out, yielding the doubling of the definite article. I argue that not only DPs that display article doubling are derived in this way, but that this derivation applies to DPs with adjectives in all Germanic languages. Hence, DPs containing adjectives have a structure with two D-copies not only in the Germanic languages displaying double definiteness, but also in all other Germanic languages. The lack of article doubling in the Germanic languages that do not display double definiteness is attributed to specific morphological properties of D in these languages.

After having determined the structure of DP in Germanic, chapter 3 investigates the syntactic configuration in which two elements should be positioned in order for agreement to be licensed. Chomsky (2000) proposes that this configuration is best defined in terms of a c-command requirement. I will propose an alternative way of defining this configuration that makes use of a dominance requirement. Adopting Bare Phrase Structure (Chomsky 1995), it is shown that Chomsky’s c-command requirement and my dominance requirement make different

empirical predictions. I then examine which of these predictions are borne out by looking at a wide array of different agreement phenomena. Unfortunately, the outcome of this investigation is inconclusive at first. Some data seem to favor c-command, while other data seem to favor dominance. Despite this, I decide in favor of my own dominance requirement, because it has the advantage of being theoretically simpler. In chapter 6, I however return to the discussion and show that the data that seem to support the c-command requirement actually constitutes, at closer inspection, support for the dominance requirement.

In chapter 4, I turn to agreement on attributive adjectives in Germanic. The chapter consists of two parts. In the first part, I first discuss the syntactic representation of the features involved in agreement. It is argued that the feature structure proposed by Chomsky (2000, 2001) poses serious learnability problems for L1 acquisition. In order to counter these problems, I propose that the syntactic representation of features depends on their morphological realization. After that, I discuss the consequences of this proposal and my proposal for a dominance requirement for the theory of Agree. In the second part of the chapter, I use the theoretical tools developed in the first part and chapter 3 to formulate my proposal about agreement on attributive adjectives in Germanic. I propose that strong adjectival inflection is the result of an Indirect Agree relation between the noun and the adjective that is established through mediation of a case-assigning head. In those contexts in which the adjective takes weak adjectival inflection, this indirect Agree relation is blocked as a result of internal merge of a deactivated D-Probe. I then illustrate in detail how the proposal accounts for agreement in attributive adjectives in Swedish, Norwegian, Danish, and Dutch.

Chapter 5 takes a closer look at agreement on attributive adjectives in German. The German pattern of agreement is of greater complexity than that of the languages discussed in Chapter 4 for two reasons. First, German has case agreement on attributive adjectives, while the languages discussed in chapter 4 do not. Second, German weak adjectival inflection displays some distinctions, contrary to its counterparts in the languages that are discussed in chapter 4. Despite this greater complexity, I show that my proposal of the strong-weak distinction straightforwardly offers a detailed account for the German data.

Chapter 6 extends the discussion to the Romance languages. As shown above, attributive adjectives in the Romance languages always fully agree with the noun. There is no strong-weak distinction in Romance. This is shown to follow directly from my analysis of agreement on attributive adjectives if an independently motivated difference between Romance and Germanic DP-structure is taken into account. In addition, I show that the analysis of agreement on attributive adjectives solves the empirical problems for defining the configuration in which agreement takes place in terms of a dominance requirement on Agree. As a result, the dominance requirement is therefore not only theoretically simpler but also empirically more adequate than Chomsky's c-command requirement.

Chapter 2

The Germanic DP: deriving double definiteness

1. Introduction

The licensing of agreement crucially depends on syntactic structure (see among others Chomsky 1995, 2001; Rezac 2003; Baker 2008). Agreement on attributive adjectives can therefore only be accounted for if the structure of DP is determined first. In order to account for the patterns of agreement on Germanic attributive adjectives, I therefore investigate in this chapter the structure of the Germanic DP. The starting point of this investigation is a construction in which the definite article is doubled, the so-called double definiteness phenomenon that occurs in some Northern Germanic languages. I propose a new analysis of this phenomenon. This analysis does not only account for the properties of the double definiteness phenomenon, but also give new insights in the structure of DPs in those Germanic languages that do not have a doubling of the definite article. The result of this chapter will be a unified account of the Germanic DP. This account will form the basis for my analysis of agreement on attributive adjectives in the following chapters.

Some of the Germanic languages have the striking property that definiteness is marked twice in the DP in certain contexts. The languages that have this double marking are Swedish, Norwegian, and Faroese. In these languages, unmodified definite DPs signal their definiteness through means of a definite suffix on the noun. This is illustrated in (1). However, if the DP contains a prenominal adjective, as in (2), definiteness is marked both by a freestanding definite article and by a suffix on the noun. The adjectives in (2) receive the so-called weak adjectival inflection, glossed as WEAK (see chapter 1). The data in (1) and (2) are taken from Julien (2005: 26-27).

- (1) a. *hus-et* [Swedish]
house-DEF.NEUTER.SG
'the house'
- b. *skjort-a* [Norwegian]
shirt-DEF.FEM.SG
'the shirt'
- c. *kettlingur-in* [Faroese]
kitten-DEF.MASC.SG.NOM
'the kitten'

2. The c-command paradox

As noted above, definite DPs in Swedish, Norwegian and Faroese display double definiteness when they contain a prenominal adjective, as in (3a). When they do not contain a prenominal adjective, double definiteness is in principle not allowed, as in (3b).¹

- (3) a. *det stor-a hus-et* [Swedish]
 the.NEUTER.SG big-WEAK house-DEF.NEUTER.SG
 ‘the big house’
 b. **det hus-et*²
 the.NEUTER.SG house-DEF.NEUTER.SG
 c. *hus-et*
 house-DEF.NEUTER.SG
 ‘the house’

Hence, the presence of a prenominal adjective licenses the double marking of definiteness. The aim of this section is to determine the properties of the prenominal adjective that play a role in this licensing.

First, I show that adjectives that trigger double definiteness differ in two ways from adjectives in other syntactic positions within the sentence. Firstly, they are interpreted differently with respect to the scope of the definite article. Secondly, they inflect differently. I then argue that each of these two properties leads to diametrically opposed syntactic structures. The adjectival inflection requires the adjective to c-command D³, while the semantic interpretation requires D to c-command the adjective. Finally, I claim that this paradox can only be resolved by analyzing definite DPs containing an adjective as consisting of a structure with two Ds.

In what follows, I will be primarily using data from Swedish. However, my analysis will straightforwardly carry over to Norwegian and Faroese, the other two languages displaying double definiteness.

¹ This is an oversimplification for the sake of the argument. There are cases in which double definiteness is allowed without a prenominal adjective. For instance (3b) is grammatical if the definite article receives a contrastive/demonstrative reading. Another case in which the double definiteness is allowed in the absence of a prenominal adjective is when the definite DP contains a numeral or weak quantifier. I will come back to these cases in section 4.1 of this chapter.

² This phrase is only unacceptable under the basic reading ‘the house’, under the demonstrative interpretation ‘that house’ it is acceptable (see fn. 1)

³ In this thesis, I take D to be the syntactic head that is responsible for transforming the property denoted by N into referential entities. I take it to be present every time a nominal constituent is referential, even when there is no determiner that spells out D. As a result, D is sometimes nul and sometimes realized by a determiner. The type shifting operation is the core property of D, but in addition D can also encode other semantic and morphosyntactic functions, like for instance exhaustivity or being a Probe for agreement. Which other properties D has besides its core function as a type-shifter is subject to cross-linguistic variation. In chapter 6, I will for instance claim that D in the Germanic languages functions as a categorizer, while another syntactic head performs that function in the Romance languages.

- (6) *The cars are blue.* PREDICATIVE
 # THE (blue (cars))
 blue (THE (cars))

The difference between *blue* in (5) and *blue* in (6) lies in its contribution to the reference of the DP. If an adjective is outside the scope of the definite article, as in (6), it does not contribute to the reference of DP. This means that the definite article in (6) picks out only those entities that are cars. Subsequently, *blue* is independently predicated over these entities. Hence, (6) can only be used felicitously in a situation in which all the cars in the domain of discourse are blue. It excludes the presence of differently colored cars. In (5), on the other hand, the adjective makes a contribution to the reference of DP. Because *blue* is in the scope of *the*, the definite article picks out those entities from the domain of discourse that are both cars and blue. As a consequence, the sentence in (5) does not exclude the existence of cars of a different color. It can therefore be uttered felicitously in a situation in which there are also red and green cars, while that is impossible for the sentence in (6). This interpretational difference is a general property of the distinction between attributive and predicative adjectives.

However, the second difference between predicative and attributive adjectives is a property specific to Germanic. This difference concerns the adjectival inflection. As mentioned in chapter 1, Germanic attributive adjectives display a strong-weak distinction. In the languages under consideration, this distinction takes the form of attributive adjectives receiving a different inflection according to the definiteness of the DP they occur in. Adjectives in indefinite DPs receive the so-called strong adjectival inflection, as illustrated in (7a). Strong adjectival inflection marks gender and number distinctions.⁶ Adjectives in definite DPs receive the so-called weak adjectival inflection, as in (7b). Weak adjectival inflection is either invariant, as in Swedish and Norwegian, or is greatly impoverished as compared to the strong inflection, as in Faroese.

- (7) a. *ett* *stor-t* *hus* [Swedish]
 a.NEUTER.SG big-NEUTER.SG.STRONG house
 ‘a big house’
 b. *det* *stor-a* *hus-et*
 the.NEUTER.SG big-WEAK house-DEF.NEUTER.SG
 ‘the big house’

This sensitivity of the adjectival inflection for definiteness is not attested with predicative adjectives. Predicative adjectives do not display a strong-weak distinction. They do not inflect differently according to the definiteness of their subject. The subject in (8a) is indefinite, while it is definite in (8b). However, the inflection is the same in both (8a) and (8b)

⁶ In Faroese, strong adjectival inflection also marks case distinctions.

- (8) a. *ett hus är stor-t* [Swedish]
 a/one.NEUTER.SG house is big-NEUTER.SG
 ‘A/one house is big’
 b. *hus-et är stor-t*
 house-DEF.NEUTER.SG is big-NEUTER.SG
 ‘The house is big’

This inflectional asymmetry between predicative and attributive adjectives is not widespread in the world’s languages.⁷ In the Germanic languages, this asymmetry does not only occur in the languages that display double definiteness, but in the other Germanic languages, with the exception of English. This is illustrated in (9) for German.

- (9) a. *das schön-e Buch* [German]
 DEF.NEUTER.SG.NOM nice-WEAK book
 ‘the nice book’
Das Buch ist schön
 DEF.NEUTER.SG.NOM book is nice.PRED
 ‘the book is nice’

Attributive adjectives, which trigger double definiteness, thus have two properties that set them apart from predicative adjectives, which do not trigger double definiteness. Firstly, they must be interpreted in the scope of a definite determiner. Secondly, their inflection is sensitive to definiteness. In the following section, I will examine what these properties tell us about the structure of modified definite DPs. It will turn out that the inflectional and interpretational properties of attributive adjectives provide apparently contradictory clues about the shape of the DP.

2.2. The c-command paradox

Above, I concluded that attributive adjectives in definite DPs are in the scope of a definite D, see (5), repeated here as (10). This conclusion was based on the observation that attributive adjectives play a role in determining the reference of a definite DP.

- (10) *the blue cars are being sold today* ATTRIBUTIVE
 THE (blue (cars))
 # blue (THE (cars))

⁷ As pointed out to me by David Pesetsky (personal communication), Russian and other Slavic languages also displays an inflectional asymmetry between predicatively and attributively used adjectives in the form of the opposition between long-form and short-form adjectives. Short-form adjectives can only be used predicatively and inflect in gender and number. Long-form adjectives agree in number and gender as well, but in addition also manifest case agreement.

I adopt here the standard assumption that *in the scope of* equals *being c-commanded by*.⁸ Under this assumption, the observation that attributive adjectives are in the scope of a definite D indicates that attributive adjectives are c-commanded by a definite D. This is formulated in (11).

- (11) WORKING HYPOTHESIS A:
Attributive adjectives in definite DPs must be c-commanded by a definite D in order to be interpreted in the scope of a definite D.

Let's now examine what the inflectional properties of attributive adjectives indicate about the structure of definite DPs. The property of the inflection of attributive adjectives that is relevant here is its sensitivity to definiteness. This sensitivity, also known as the strong-weak distinction, was illustrated above in (7), repeated here in (12).

- | | | | | | |
|------|----|-----------------|----------------------|---------------------|-----------|
| (12) | a. | <i>ett</i> | <i>stor-t</i> | <i>hus</i> | [Swedish] |
| | | a.NEUTER.SG | big-NEUTER.SG.STRONG | house | |
| | | 'a big house' | | | |
| | b. | <i>det</i> | <i>stor-a</i> | <i>hus-et</i> | |
| | | the.NEUTER.SG | big-WEAK | house-DEF.NEUTER.SG | |
| | | 'the big house' | | | |

The null hypothesis about adjectival agreement is that it is licensed by the same mechanism that is used in other instances of agreement. In standard minimalism, agreement is licensed in syntax through the relation Agree (Chomsky 2000). Agree is subject to a structural licensing condition: Agree can only be established if the Probe, the head bearing uninterpretable features, c-commands the Goal, which is the element that has interpretable features.^{9,10} In the case of the adjectival agreement in (12), the adjective is the Probe for the following reasons. Firstly, it bears uninterpretable gender and number features that it adopts from the noun it modifies. Secondly, the shape of its inflection is sensitive to the definiteness of the DP. Given its status as a Probe, the adjective needs to c-command all the nodes that bear the interpretable features that are relevant for determining its inflection. Because definiteness is one of these features, the adjectival Probe must have an interpretable definiteness-feature in its search domain. Under the standard assumption that

⁸ In this thesis, I adopt, Chomsky's (1995: 33) definition of c-command: α c-commands β if α does not dominate β and every γ that dominates α dominates β (i.e. α c-commands its sister and everything that is contained in its sister). In chapter 3, I discuss c-command in more detail.

⁹ In chapter 3, I will propose to replace this structural condition on Agree with an alternative condition. Chomsky's (2000) structural condition however suffices for the present discussion.

¹⁰ Note that this definition of the structural licensing condition on Agree is unidirectional. Under this definition, Agree can only be established in case the Probe c-commands the Goal. It cannot be established if the Goal c-commands the Probe without the Probe also c-commanding the Goal. There are however also bidirectional definitions of the structural condition on Agree, as in Baker (2008). According to these definitions, Agree can be established in case the Probe c-commands the Goal, but also if the Goal c-commands the Probe. In this thesis, I will adopt the null-hypothesis that the structural condition on Agree is unidirectional. A bidirectional definition of this condition is less restrictive and therefore does not constitute the null hypothesis (see also chapter 2).

definiteness is a feature of D and given the c-command requirement on Agree, I conclude that the adjective in (12b) c-commands a definite D.¹¹ This conclusion is formulated in (13) as working hypothesis B.

- (13) WORKING HYPOTHESIS B:
If the inflection of the adjective is sensitive to definiteness, the adjective must c-command a definite D

However, when the hypothesis in (11) is combined with the one in (13), we reach a contradictory result. On the one hand, in the languages that display double definiteness, the interpretation of attributive adjectives indicates that they should be c-commanded by a definite D. On the other hand, the adjectival inflection indicates that these adjectives c-command a definite D. Hence, I arrive at the rather paradoxical conclusion that in definite DPs the adjective both c-commands and is c-commanded by a definite D. This paradox is formulated in (14).

- (14) C-COMMAND PARADOX
Attributive adjectives with weak adjectival inflection must be c-commanded by a definite D for their interpretation, but they must c-command a definite D in order to license their inflection.

Given this paradox, definite DPs containing a prenominal adjective cannot contain a single D-head. If that were the case, definite DPs containing an adjective should necessarily consist of a structure in which there is a mutual c-command relation between D and A, as in (15). In the case of mutual c-command between A and D, both the correct interpretation of the adjective and its inflection can be licensed.

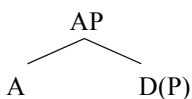
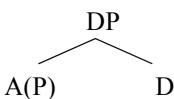
- (15) a.  b. 

However, there is a problem with having mutual c-command between D and A, as in (15). It is incompatible with the observation that N is interpreted in the scope of the definite D. For instance, in a definite DP like (12b), repeated here in (16), the definite article picks out the entity that is both *big* and *house*.

- (16) *det* *stor-a* *hus-et*
the.NEUTER.SG big-WEAK house-DEF.NEUTER.SG
'the big house'

¹¹ This reasoning is an oversimplification for the sake of the argument. It abstracts away for instance from the fact that prenominal adjectives may take complements and degree modifiers while still displaying weak adjectival inflection.

In chapters 4 and 5, I will come back to the licensing of adjectival inflection in Germanic. In these chapters, I will propose a different view of how adjectival inflection is licensed. Under that view, complements and modifiers of DP do not pose a problem for the licensing of the adjectival inflection. The basic insight that the adjective must be attached higher than D will be retained under that analysis, although it will be formulated in slightly different terms.

Under the assumption that in the *scope of* equals being *c-commanded by*, this signifies that N must be c-commanded by a definite D, as for instance in (17).

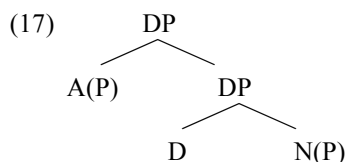

However, it is impossible to have a structure in which D and A are in a mutual c-command relation and D simultaneously c-commands N. Mutual c-command between A and D would require that A and D are non-branching sisters of each other, as in (15). Whereas D c-commanding N would require that N is or is contained in the sister of D. These two requirements are incompatible in a binary branching structure. Therefore, it is not possible to analyze definite DPs with a prenominal adjective as involving only one D.¹² In the following section, I therefore propose a structure with two Ds. This will resolve the paradox in (14), while taking into account the observation that N is in the scope of a definite D.

2.3. Outline of the proposal

To solve the paradox, I propose that definite DPs actually contain two Ds. The lower one of these Ds is c-commanded by the adjective. Hence, it is in the search domain of the adjectival Probe. This explains the sensitivity of the adjectival inflection for definiteness. The higher D c-commands the adjective. In that way, the adjective can be interpreted in the scope of a definite D. Both Ds c-command the noun. This offers an explanation of why the noun is interpreted in the scope of the definite article. As far as the phonological realization is concerned, I propose that the higher D is spelled out as the free definite article, while the lower D gets realized as a suffix on D. On the assumption that adjectives are adjuncts (Svenonius 1994; Bernstein 1991; Ritter 1992; among many others), the definite DP in (18a) has the structure in (18b).¹³

¹² An additional problem of the structures in (15) is that they cannot be linearized if one adopts a linearization algorithm which depends on asymmetric c-command relations between terminal nodes, such as Kayne's (1994) LCA.

¹³ David Pesetsky (personal communication) points out that there is another possible derivation of DP with adjectives that would resolve the c-command paradox. This derivation would involve adjectives that are initially be adjoined lower than D and subsequently moved over D as in (i).

(i) A [D [_{t_A} N]

In (i), the lower copy of the adjective is c-commanded by D and hence would allow the adjective to be interpreted inside the scope of D. The higher copy on the other end would c-command D explaining in this way the sensitivity of the adjectival inflection for definiteness.

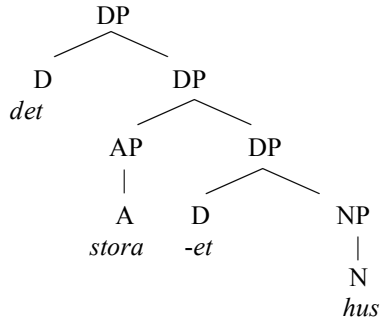
- (18) a. *det* *stor-a* *hus-et* [Swedish]
 the.NEUTER.SG big-WEAK house-DEF.NEUTER.SG
 ‘the big house’
- b.
- 
- ```

graph TD
 DP1[DP] --- D1[D]
 DP1 --- DP2[DP]
 D1 --- det[det]
 DP2 --- AP[AP]
 DP2 --- DP3[DP]
 AP --- A[A]
 A --- stora[stora]
 DP3 --- D2[D]
 DP3 --- NP[NP]
 D2 --- et[-et]
 NP --- N[N]
 N --- hus[hus]

```

The structure in (18b) involves adjunction of the adjective to DP. In section 3.3.1 below I will motivate this adjunction in terms of late adjunction and the phasehood of DP.<sup>14</sup>

Furthermore, I claim that the presence of the higher D (18a) is only licensed in order to bring the adjective in the scope of the definite D. In unmodified definite DPs, like the one in (19a), there is no need for this. Therefore, I propose that these contain only one D. This D is realized as the definite suffix.

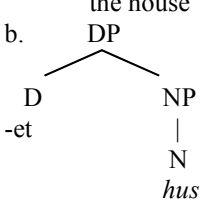
- (19) a. *hus-et*                      [Swedish]  
          house-DEF.NEUTER.SG  
          ‘the house’
- b.
- 
- ```

graph TD
    DP1[DP] --- D1[D]
    DP1 --- NP1[NP]
    D1 --- et[-et]
    NP1 --- N1[N]
    N1 --- hus[hus]
  
```

In the following section, I will discuss and motivate this proposal in more detail. I argue that the higher D in (18b) is the result of internal merge of the lower D. In addition, I take the spell-out of the D as a definite suffix on the noun to be the result of a postsyntactic movement operation in the morphological component of the grammar.

This derivation however suffers from the drawback that it is unclear what triggers the movement of the adjective. If it were the adjectival agreement, one would have a case in which movement takes place in order for Agree to be established. In minimalism (Chomsky 2000, 2001), it is however standardly assumed that movement can take place because Agree has been established prior to Agree. Hence it seems unlikely that the need to establish an Agree-relation is the trigger of the movement. I therefore reject the derivation in (i) as a potential alternative to (18b).

¹⁴ In chapter 6, this motivation will however be replaced with an alternative motivation that will also be able to account for adjectival agreement in Romance.

3. The proposal

Above, I argued that double definiteness involves a DP-structure with two D-heads. The motivation for this claim was that two Ds are needed in order to license the adjectival inflection and to interpret at the same time the adjective inside the scope of the definite article. The two Ds were both phonologically realized: one as the free definite article and the other as the definite suffix on the noun. In this section, I discuss in detail how the presence of a second D-head is licensed in the syntactic component of the grammar. Furthermore, I will show how the morphological component ensures that both the D-heads are phonologically realized.

I will first introduce the assumptions I adopt about the structure of the grammar. I will then discuss the derivation of definite DPs without an adjective. Finally, I investigate in full detail the derivation of definite DPs that contain an adjective and display double definiteness.

3.1. Theoretical background

In this thesis, I adopt the Distributed Morphology (Halle & Marantz 1993; Harley & Noyer 2003) model of the grammar. In this model, particular vocabulary items are absent in Narrow Syntax. The syntactic component of the grammar only operates on morphosyntactic feature-bundles. Vocabulary items enter the derivation in the postsyntactic morphological component. The point in the derivation at which this takes place is called Vocabulary Insertion. The Distributed Morphology model of the grammar is schematized in (20), which is based on the schema in Harley & Noyer (2003: 465, (1)).

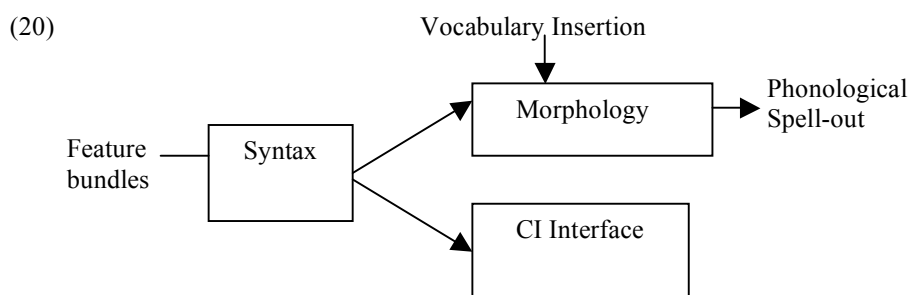

Furthermore, I will follow Embick & Noyer's (2001: 562) *late linearization hypothesis* by assuming that Linearization takes place at or right after Vocabulary Insertion. Linearization maps the hierarchical structure in which the vocabulary items are inserted on a linear string in accordance with Kayne's (1994) LCA or a similar linearization procedure. I will use Embick & Noyer's (2001) notation for

linearized strings. In this notation, the ‘*’ sign indicates that the vocabulary item to the left of the sign immediately precedes and is adjacent to the vocabulary item to the right of the sign. So, $a * b$ means that the vocabulary item a precedes and is immediately adjacent to vocabulary item b .

Finally, I follow Embick & Noyer’s (2001) proposal that Local Dislocation can manipulate the linear sequence of vocabulary items created by Linearization. Local Dislocation is a post-syntactic movement operation. It takes a vocabulary item x and right-adjoins it to y , the vocabulary item to its right. The result of this adjunction is that x is now part of the newly complex vocabulary item y .

$$(21) \quad [X * [Y * Z]] \quad \rightarrow \quad [Y+X]_Y * Z$$

Local Dislocation has two properties that are relevant for the present discussion. First, it can only affect adjacent elements. Secondly, it applies after Vocabulary Insertion. Because of this second property, Local Dislocation in principle has access to idiosyncratic properties of specific vocabulary items, such as their phonological form. Crucially, these properties were not present in the derivation before Vocabulary Insertion. Movement operations that apply before Vocabulary Insertion, like head movement or lowering, do not have access to such properties. In the framework of Embick & Noyer (2001), Local Dislocation is the only movement operation that can operate after Vocabulary Insertion. As a consequence, Local Dislocation is also the only movement operation that can be sensitive to idiosyncratic properties of vocabulary items (or vocabulary sensitive in Embick & Noyer’s words). Given that Local Dislocation only affects adjacent vocabulary items, a movement operation that is sensitive to idiosyncratic information of vocabulary items, such as their phonological properties, should necessarily only affect string adjacent vocabulary items. This is Embick & Noyer’s Local Dislocation hypothesis (22).

- (22) LOCAL DISLOCATION HYPOTHESIS
 If a movement operation is vocabulary sensitive, it involves only string adjacent items. (Embick & Noyer 2001:566)

Below, I claim that the suffixation of the definiteness suffix is the result of Local Dislocation. I will now first analyze definite DPs in Swedish that do not contain an adjective.

3.2. Definite DPs without an adjective

As illustrated in the introduction, unmodified definite DPs in Norwegian, Faroese, and Swedish do not display double definiteness. Instead, they mark their definiteness solely through means of a suffix on the noun, as in (23).

- (23) a. *hus-et* [Swedish]
house-DEF.NEUTER.SG
‘the house’
b. *bil-en*
car-DEF.NON-NEUTER.SG
‘the car’

As far as their syntactic structure is concerned, I propose that unmodified definite DPs consist of a simple DP-structure in which a D-head takes a NP complement.¹⁵ Under this proposal, the outcome of the syntactic part of the derivation for (23a) is the structure in (24a). Following the Distributed Morphology model of the grammar, the terminal nodes D and N are at this point only associated with morphosyntactic feature bundles. Specific vocabulary items are associated with D and N after the structure in (24a) is handed over to the morphological component. In (23a), definiteness is expressed by the suffix *-et*. Assuming that definiteness is a property of D, Vocabulary Insertion inserts this definiteness suffix in D. In addition, Vocabulary Insertion inserts the noun *hus* in N. The result of Vocabulary Insertion is illustrated in (24b). After Vocabulary Insertion, the structure needs to be linearized, according to Kayne’s (1994) LCA. This results in the string in (24c). In this sequence of vocabulary items, the definite suffix *-et* precedes the nominal root. Since it is a nominal suffix, it has to attach to the right of the nominal root before the derivation reaches the phonological component of the grammar. In order to satisfy the suffixal character of *-et*, I propose that the definite suffix undergoes Local Dislocation. Local Dislocation right-adjoins the definite suffix to the nominal root, as in (24d). The result of this derivation is finally sent off to the phonology as in (24e).

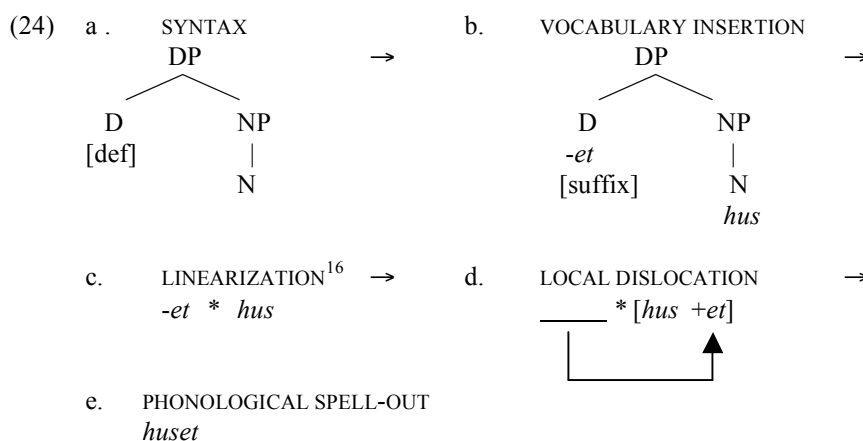

¹⁵ I will abstract away from possible functional projections between NP and D, like NumP. See Julien (2003, 2005) & Roehrs (2006) for proposals.

¹⁶ I follow Embick & Noyer (2001: 362) by using the notation *a * b* to denote that *b* follows *a* and is linearly adjacent to *a* (see above).

The analysis proposed here differs from previous analyses with respect to the way in which the definiteness marker is attached to the noun. In the analysis defended here, this is done through Local Dislocation. Most other analyses (Delsing 1993; Embick & Noyer 2001; Julien 2002, 2003, 2005 among others) propose that this is the result of head movement of N to the position associated with the definiteness marker. I argue that there is good reason to prefer Local Dislocation to head movement in this case.

As indicated in the previous section, Local Dislocation happens after Vocabulary Insertion. For this reason, it has access to idiosyncratic properties of particular vocabulary items. Head movement takes place in the syntactic module of the grammar and, hence, before Vocabulary Insertion. Therefore, it has no access to idiosyncratic properties of vocabulary items. As I will show below, the suffixation of the definiteness marker is blocked with certain nouns. This shows that the operation that takes care of the suffixation is sensitive to the vocabulary item inserted in N. For this reason, it needs to apply after Vocabulary Insertion. Hence, the suffixation cannot be the result of head movement. However, it can be the result of Local Dislocation. There are no other operations after Vocabulary Insertion capable of attaching the definiteness marker in (24) to the right of the nominal stem. Therefore, the suffixation must be the result of Local Dislocation.

The nouns that block suffixation of the definiteness marker are Swedish deverbal non-neuter nouns ending in *-ende*, like *studerende* ‘student’ (Hankamer & Mikkelsen 2002, 2005).¹⁷ These nouns cannot occur with the definite suffix.¹⁸ If *studerende* ‘student’ were like a regular Swedish noun, one would expect the form in (25a) (cf. *bil-en* ‘the car’). However, this form is ungrammatical. Instead, the freestanding definite article is used (25b) (cf. **den bil* ‘the car’).

- (25) a. * *studerend-en* [Swedish]
 student-DEF.NON-NEUTER.SG
 b. *den* *studerende*
 the.NON-NEUTER.SG student
 ‘the student’ (Hankamer & Mikkelsen 2005: 103)

¹⁷ Hankamer & Mikkelsen signal that these nouns do not occur with the definite suffix in Danish as well. I will leave Danish out of the discussion for now, because it does not display double definiteness. However, Embick & Marantz (2008) propose that the definite suffix in Danish also undergoes Local Dislocation, just like I am proposing here for Swedish. I will come back to Danish in section 5.2. Although the definite suffix undergoes Local Dislocation in my analysis as well, my analysis of Danish is radically different from that of Embick & Marantz.

¹⁸ The *-ende* ending is the present participle form of the verb. As present participles can be used attributively, as in *a dying man*, one might be inclined to entertain the hypothesis that *studerende* is the modifier of an empty noun. However, Hankamer & Mikkelsen (2002: 147-150) argue that this is not the case. They demonstrate that *studerende* behaves like a nominal head with respect to modification, and its role in the discourse.

David Pesetsky (person communication), however, suggests that the data Hankamer & Mikkelsen use to support their argument can also be used as support for an analysis in which *studerende* is an A-N idiom with a null noun. In that case, the absence of the definiteness suffix on *studerende* would be due to the fact that *studerende* is not a noun. At the moment, I do not see how this suggestion can be implemented in the framework I am using here. I will therefore leave this suggestion for future research.

Hankamer & Mikkelsen (2002, 2005) conclude that some idiosyncratic property of *-ende* nouns excludes them from being a host to the definiteness suffix. As argued above, this shows that the process that takes care of suffixation of the definiteness marker should be sensitive to the noun that is inserted in N. The suffixation of the definite suffix can therefore not be due to head movement. In the framework of Embick & Noyer (2001), head movement applies before Vocabulary Insertion. Therefore, if head movement were the operation that takes care of the suffixation of the definiteness marker, one would expect that it take place independently of the noun inserted in N. As the ungrammaticality of (25a) shows, this is contrary to fact. However, if the suffixation of the definiteness suffix is the result of Local Dislocation, (25a) can be ruled out. Local Dislocation applies after Vocabulary Insertion. In the case of (25), *studerende* is inserted in N. *Studerende*, like the other *-ende* nouns, is not a suitable host for the definiteness suffix. As a consequence, Local Dislocation is blocked (26a). This explains why (25a) is ungrammatical, but it does not explain why we have (25b). I argue that this form shows up as a last resort option to satisfy the suffixal properties of the definiteness marker. Once Local Dislocation fails to attach it to the noun, a dummy host *d-* is inserted in order to host the definiteness marker (cf. the *d*-support in Santelmann 1993 & Roehrs 2006) (26b). In this way, the suffixal properties of the definiteness marker are satisfied.

- | | | | |
|---------|-------------------------------------------------------------------------------------------------|----|--------------------------------------------------|
| (26) a. | VOCABULARY INSERTION &
LINEARIZATION
<i>-en</i> * <i>studerende</i>
[suffix] [no host] | b. | D-SUPPORT

<i>d-en</i> * <i>studerende</i> |
|---------|-------------------------------------------------------------------------------------------------|----|--------------------------------------------------|

The impossibility of the definite suffix to occur on *-ende* nouns thus forms an argument in favour of my claim that the definiteness marker is suffixed onto the noun through Local Dislocation, instead of head movement.¹⁹

3.3. Modified definite DPs

After discussing my analysis of unmodified definite DPs, I will now turn to definite DPs with adjectives. Recall that if an adjective is added to a DP consisting of noun with a definite suffix, an additional freestanding definite article is needed. This is illustrated in (27a-c).

¹⁹ My Local Dislocation account is quite similar to Hankamer & Mikkelsen's (2005) Distributed Morphology account. However, Hankamer & Mikkelsen's account differs in two respects. Firstly, they do not use *d*-support. Instead they argue that the appearance of *den* is due to competition between two vocabulary items. However, they need a revised version of Halle's (1997) subset principle to do so. Secondly, they use ad-hoc linearization rules in order to explain the suffixation of the definite suffix. My account is less stipulative since it appeals to Local Dislocation for suffixation. In addition, the use of *d*-support ensures that a reformulation of the subset principle is not needed.

- (27) a. *hus-et* [Swedish]
house-DEF.NEUTER.SG
‘the house’
- b. * *stor-a hus-et*
big-WEAK house-DEF.NEUTER.SG
‘the big house’
- c. *det stor-a hus-et*
the.NEUTER.SG big-WEAK house-DEF.NEUTER.SG
‘the big house’

In this section, I will discuss in detail how double definiteness arises in (27c).

3.3.1. Adjunction of AP to DP

In section 2, I showed that the inflection of attributive adjectives in Swedish is sensitive to the definiteness of the DP they occur in. This sensitivity manifests itself through the shape of the adjectival inflection. In definite DPs, Attributive adjectives receive the so-called weak inflection, while they get the so-called strong inflection in indefinite DPs. This was illustrated in (7), repeated here as (28).

- (28) a. *ett stor-t hus* [Swedish]
a.NEUTER.SG big-NEUTER.SG.STRONG house
‘a big house’
- b. *det stor-a hus-et*
the.NEUTER.SG big-WEAK house-DEF.NEUTER.SG
‘the big house’

In section 2.2, I argued that this sensitivity to definiteness shows that attributive adjectives are merged at a position that c-commands a D. In that case, the adjectival Probe will have D in its search domain. On the assumption that definiteness is a feature of D, this explains the sensitivity of the adjectival inflection for definiteness. I adopt here the view that attributive adjectives are adjuncts (cf. Svenonius 1994 for a discussion why this view is to be preferred over other views). I propose that attributive adjectives are adjoined to DP. DP is the nearest adjunction site from D that permits the adjective to c-command D. In the previous section, I analyzed definite DP as consisting of a D that takes an NP complement, as in (24a) above. I propose that attributive adjectives are merged as adjuncts to this DP-structure. After merger of the adjective, the syntactic derivation of (27c) will look like in (29). From now on, I follow Embick & Noyer (2001) and Hankamer & Mikkelsen (2005) by summarizing the feature content of lexical nodes in syntactic structures by using their final phonological form preceded by the root symbol. Note, however, this is only done to simplify the tree structures. On the model I assume here, the actual phonological form is not present in syntax.

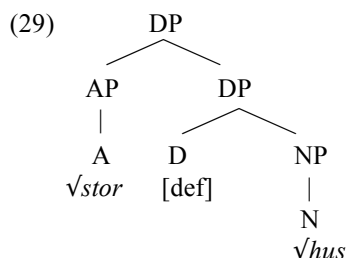

After adjunction of AP to DP, the adjectival Probe will look down its c-command domain for interpretable features to Agree with.²⁰ In its c-command domain, the adjectival Probe will find the definite D and hence the weak adjectival inflection is licensed.

As argued above, the sensitivity of the adjectival inflection to definiteness shows that attributive APs must c-command D. If it does not c-command D, this sensitivity remains a mystery. Consider for instance the structure in (30), in which AP is adjoined to NP instead of DP.

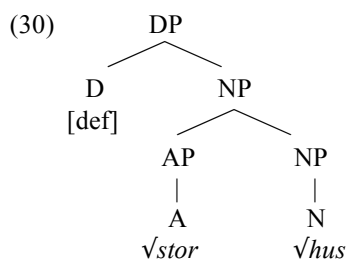

In (30), AP does not c-command D. When it probes down, AP will therefore not find a definite D in its search domain. Hence, if (30) were the correct structure of DPs containing an adjective, Swedish adjectival inflection would not display any sensitivity to definiteness, contrary to fact. In addition to this empirical motivation, I would like to suggest that there is also a theoretical reason for which attributive APs need to adjoin to DP. More specifically, I suggest that adjunction to projections other than DP, such as NP in (30), is not an option, because of the late insertion of adjuncts.

Stepanov (2001) argues that adjuncts must be adjoined post-cyclically. Above, I adopted the view that attributive adjectives are adjuncts. Hence, attributive adjectives must be merged post-cyclically. What would it mean for an adjective to be merged post-cyclically? In a phase-based approach to syntactic derivations, as in Chomsky (2001), syntactic derivations are made up of a limited number of smaller subparts, or cycles, called phases. Once a phase has been built by the syntactic

²⁰ This view of how adjectival agreement is licensed is too simple. It abstracts for instance away from the fact that adjectives agreeing with N can also take complements. It will therefore be changed in chapters 3 and 4 below (see also fn. 11 above for more on why this view is too simple). These changes will, however, not affect the essence of the analysis proposed here.

component, it will be shipped off to the SM- and CI-interfaces, and, except for its edge, become opaque for further syntactic operations (the Phase Impenetrability Condition, PIC). If adjuncts are merged post-cyclically in syntax, they should be merged after the phase-head, but before the phase is sent off to the interfaces. Heck & Zimmermann (2004) argue that only elements on the left edge of a DP are available for further syntactic computations. Hence, DPs display typical phasehood behaviour. From this, they conclude that DP is a phase.²¹ I adopt this conclusion. If DP is a phase and adjectives are adjuncts, adjectives should be merged after merger of D, the phase-head, and before the DP-phase is sent to the SM and CI interfaces.

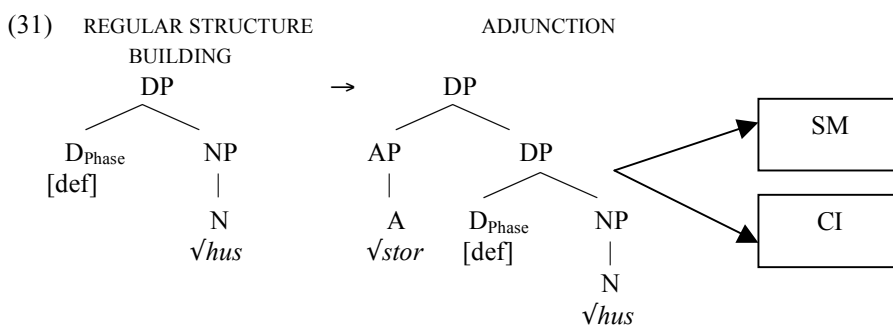

In (31), the AP is adjoined to DP. However, late adjunction as such does not prevent the adjunct from being merged at the NP-level, as in (30). In principle, the adjunct could be adjoined to NP at a point in the derivation when the D-head has already been merged. However, such an adjunction to NP is prohibited because it violates Chomsky's (2005) No Tampering Condition. The No Tampering Condition prohibits any instance of merge that is not at the edge. If the AP is merged at the NP-level after merger of D, the AP will not be merged at the DP-edge. Such adjunction violates the No Tampering Condition. The No Tampering Condition forces the adjective to be merged at the edge of the DP-phase, as in (31).²² In this way, the adjunction of AP to DP receives a theoretical motivation in addition to its empirical motivation.²³

²¹ The phasehood of DP has also been suggested in Chomsky (2001) and McCloskey (2000), but without extensive argumentation. See Matushansky (2005) for additional arguments in favor of, but also against the phasehood of DP.

²² Stepanov (2001), on the contrary, allows for adjunction to take place counter-cyclically in violation of the No Tampering Condition. The problem with this is that it is unclear how the adjunct determines the site where it is adjoined. As adjuncts are unselected, the only way to determine their adjunction site is via their semantic properties. However, this would introduce a CI-look-ahead for adjunction. This is unwanted and I believe is unnecessary if one adopts the system proposed here in which adjunction is always to a phase-edge.

²³ In chapter 6 below, I will come back to this phase-based motivation and review whether it can still be maintained given the analyses that will be developed in the following chapters. It will eventually turn out that it eventually cannot be maintained. It will therefore be replaced by a different motivation that relies on the way in which the semantic function of categorization guides the structure building of DP.

3.3.2. Internal merge of D

As noticed above in section 2.2, the interpretation and the inflection of attributive adjectives seem to demand different DP-structures. In order to explain the sensitivity of the adjectival inflection to definiteness, attributive APs need to c-command D. However, in order to license their interpretation, they need to be in the scope of a definite D, and hence be c-commanded by a definite D. This is the c-command paradox from section 2.2. Above, I proposed that attributive APs are adjoined to DP. This offers an explanation for the sensitivity of the adjectival inflection for definiteness. However, it puts attributive APs outside the scope of a definite D, contrary to their actual interpretation. In order to resolve the paradox, I propose that D is internally merged at a position that c-commands the adjoined AP, as in (32).

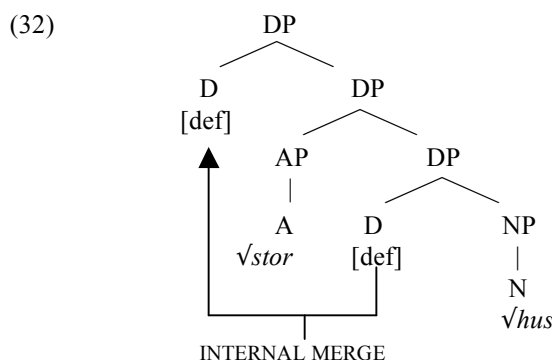

Internal merge of D has as a consequence that AP is c-commanded by a D. This ensures that A can be interpreted in the scope of D, resolving in this way the c-command paradox.

The internal merge of D in (32) has as a result that AP is interpreted in the scope of D. However, this internal merge cannot be directly triggered by the need of the adjective to be interpreted inside the scope of a definite D. The interpretation of syntactic structure happens in the post-syntactic semantic component of the grammar. Hence, instances of internal merge triggered by interpretational requirements, like scope, would involve an unwanted look-ahead. For this reason, I propose an alternative trigger of internal merge of D in (32), namely a type mismatch created by external merge of AP to DP.

Above, I adopted a Distributed Morphology model of the grammar (see the schema in (20) above and its discussion). In this model, syntax operates over bundles of features (Halle & Marantz 1993; Harley & Noyer 2003). I assume that semantic types are part of these feature bundles. Semantic types indicate two things. First, the semantic type of an element α indicates the type of an element β , with which α should be merged in order for Functional Application to apply successfully in the semantic component of the grammar. Secondly, the semantic type indicates the type of the constituent formed through merge of α and β . If a semantic type is not matched (i.e. merged with a constituent with the type required) during the syntactic derivation, the input to the semantic component will be uninterpretable, i.e.

functional application will not be able to interpret the structure in the semantic component. For this reason, semantic types have to match before the derivation reaches the CI-interface or the derivation will crash. Normally, merge will only combine objects with matching types. In that case, the derivation proceeds normally until it reaches the CI-interface. However, sometimes merge needs to combine two syntactic objects that do not have matching types in order to ensure that other requirements of the syntactic objects can be met, as in (33a). In that case, I follow the main spirit of Heim & Kratzer's (1998) proposal that the type mismatch can be repaired through internal merge, although my implementation differs a bit from theirs. Internal merge will take one of the sources of the type mismatch and merge it at a position in which it does not create a type mismatch, as in as in (33b). Heim & Kratzer's (1998) implementation of this idea is that quantified object DPs undergo Quantifier Raising in order to resolve a type mismatch.²⁴ Internal Merge creates a chain consisting of two copies of the internally merged element: the lower copy, which causes the type mismatch, and the higher copy, which does not. At the CI-interface, the higher is interpreted, as in (33c), while the lower copy is converted to a variable. In this way, the type mismatch is avoided and there will be no crash at the CI-interface.

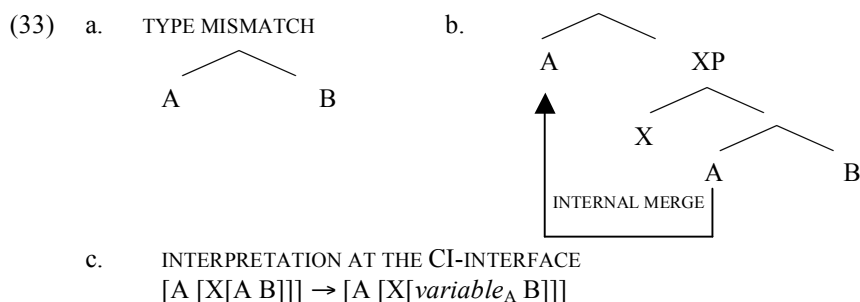

From this point of view, semantic types are syntactic features that prevent the syntax from generating structure that cannot be interpreted in the semantic component of the grammar.

I claim that the internal merge of D in (32) involves a similar derivation. As argued above, attributive APs should be merged as DP adjuncts, otherwise the adjectival inflection does not get licensed properly. Additionally, if my theoretical explanation in terms of late insertion of the adjective and the phasehood of DP is on the right track, this is the only possibility for attributive adjectives to be inserted in the syntax. Merge of the adjective at an earlier point of the derivation is excluded through late adjunction, while merge at a later point of the derivation would leave the adjective dissociated from the nominal projection line. For these reasons, there is

²⁴ In Heim & Kratzer (1998), movement (i.e. internal merge) that is triggered by a type mismatch takes place at LF. In the model of the grammar I assume here, there is no covert LF part in syntax. Instead, all instances of internal merge take place in Narrow Syntax. This puts QR in the syntax (see among others Bobaljik 2002). In the case of a chain consisting of two copies, deletion of the higher copy in the morphological component and deletion of the lower copy at the CI-interface will yield the same effect as the old LF-movement (see Bobaljik 2002: 199).

no other option than to adjoin the adjective to DP. However, adjoining the adjective to DP causes a type mismatch. Attributive adjectives are of type $\langle\langle e,t\rangle, \langle e,t\rangle\rangle$, i.e. they need to combine with a predicative constituent and the result is a new predicative constituent. However, definite referential DPs are not of type $\langle e,t\rangle$, they are of type $\langle e\rangle$ (from Frege's perspective (Frege 1892); see Heim & Kratzer 1998: 74).²⁵ Hence, merge of an attributive adjective of type $\langle\langle e,t\rangle, \langle e,t\rangle\rangle$ with a definite DP of type $\langle e\rangle$ leads to a type mismatch (34).²⁶

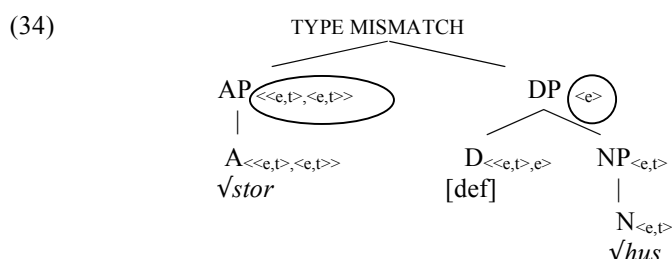

The type mismatch in (34) has to be resolved before the derivation is sent to the interfaces. Otherwise, the derivation will crash at the CI-interface. In order to resolve the type mismatch, internal merge is triggered in the way described above. To be more precise, I propose that D gets copied and merged with the already formed structure, as in (35).²⁷ Because the type mismatch is detected during the syntactic derivation, the triggering of internal merge does not involve any look ahead.

²⁵ Or $\langle\langle e,t\rangle, t\rangle$, if one adopts Russell's view of definite descriptions (Russell 1905). It does not matter whether we assume that definite DPs are of type $\langle e\rangle$ or $\langle\langle e,t\rangle, t\rangle$, adjunction of the AP to DP will cause a type mismatch in both cases. For ease of exposition, I assume here that definite descriptions are of type $\langle e\rangle$.

²⁶ Note that this presupposes that there are separate lexical entries for attributive and predicative adjectives. If this were not the case and adjectives were ambiguous between an attributive type $\langle\langle e,t\rangle, \langle e,t\rangle\rangle$ and a predicative type $\langle e,t\rangle$, no type mismatch would be created by adjoining the adjective, since the predicative type $\langle e,t\rangle$ is compatible with referential DPs of type $\langle e\rangle$. I thank Sjef Barbiers (personal communication) for pointing this out to me.

²⁷ The type mismatch in (34) is between AP and DP. Therefore, it might be surprising that it is D that undergoes internal merge and not DP, the syntactic object that causes the type mismatch. Note however that D is indirectly responsible for the type mismatch, in the sense that its type determines the type of the DP that causes the type mismatch. For this reason, I would like to suggest here that type the mismatch between D and AP is capable of triggering internal merge of D. However, this does not offer an explanation as to why it is D that undergoes internal merge and not DP. I will leave this question to further research.

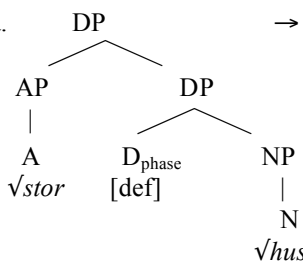
(35) a.  → Copy: D [def, +phase]

b. → Merge the copied D:

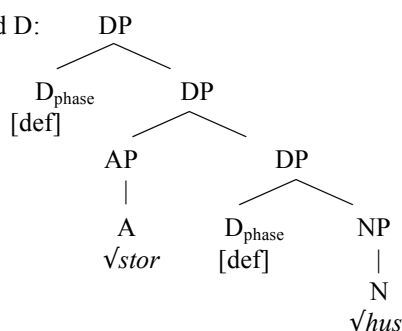

3.3.3. Interpretation at the CI-interface

The two copies of D in (35) together form a chain $\langle D, D \rangle$. At the CI-interface, only one member of a chain is interpreted (see Chomsky 1995, Bobaljik 2002 among others). In the case at hand, the lower D-copy is involved in a type mismatch. It determines the type of the DP to which AP is merged. Merge between this DP and AP creates the type mismatch. Therefore, if the lower D-copy is interpreted, the derivation will crash at the CI-interface. However, interpreting the higher copy does not encounter this problem. For this reason, the higher copy of D is interpreted, while the lower copy of D is deleted.

Note that I diverge here from Heim & Kratzer (1998)'s account of QR. On Heim & Kratzer's account the lower copy of the quantifier is converted to a variable (see above). On my account of double definiteness, the lower D-copy is completely deleted at the CI-interface.

Once the lower D-copy is deleted, the labels and semantic types of the projection of the lower D-copy also become invisible, as in (36), because they directly depend on that of the lower D.

(36) CI-INTERFACE: D-COPY DELETION

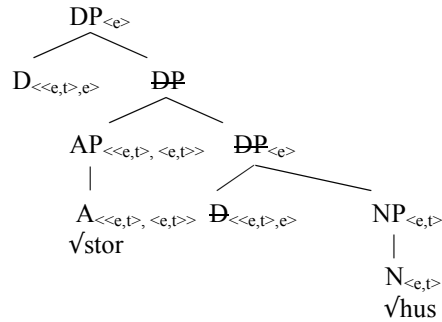

The deletion of the lower D-copy and its projection has as a consequence that AP combines with NP in the eyes of the CI-interface. Thus, the input to the semantic component is as in (37).

(37) INPUT SEMANTIC COMPONENT:

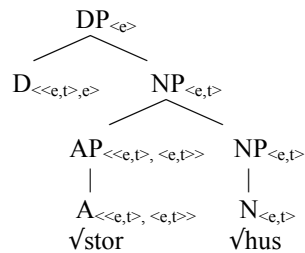

In (37), the type of AP ($\langle\langle e,t\rangle, \langle e,t\rangle\rangle$) matches that of NP ($\langle e,t\rangle$). Hence, the deletion of the lower D-copy resolves in this way the type mismatch. The higher copy of D in (37) is not involved in any type mismatch. At the CI-interface, its semantic type will match with its complement, which is now of type $\langle e,t\rangle$ as a result of the deletion of the lower copy of D. In this way, copying of the definite D prevents a type mismatch of reaching the CI-interface. As the higher copy c-commands AP, the interpretation of the higher D-copy at the CI-interface also ensures that the attributive adjective is correctly interpreted in the semantic component. The higher D c-commands the attributive AP. Hence, AP is in the scope of a definite D.

I now have explained in detail how the syntactic component of the grammar resolves the c-command paradox introduced in section 2.2. The attributive AP is adjoined to DP. In this way, it c-commands D. This explains the sensitivity of the adjectival inflection for definiteness. However, adjoining AP to DP creates a type mismatch. This type mismatch is repaired through movement of D to a higher position and deletion of the lower copy at the CI-interface. This puts the attributive AP in the scope of the definite article, corresponding to its actual interpretation. The result of all these operations is the syntactic structure in (35b). This structure is

submitted to both the SM- and CI-interfaces.²⁸ Above, I already discussed what happens when it is submitted to the CI-interface. I will now discuss how the derivation proceeds after it is submitted to the SM-interface.

3.3.4. Morphology

After it is sent off to the SM-interface, the structure in (35b) will enter the morphological part of the derivation. I will show that the operations in this part of the derivation result in the spell-out of both Ds of (35b). The morphological derivation is partly the same as with unmodified definite DPs (see section 3.2). Like their unmodified counterparts, definite DPs containing an adjective will undergo Vocabulary Insertion, Linearization, and Local Dislocation. First, Vocabulary Insertion will insert the vocabulary items that match the syntactic feature bundles. In the derivation of the definite DP in (27c), *det stora huset* ‘the big house’, Vocabulary Insertion results in (38).

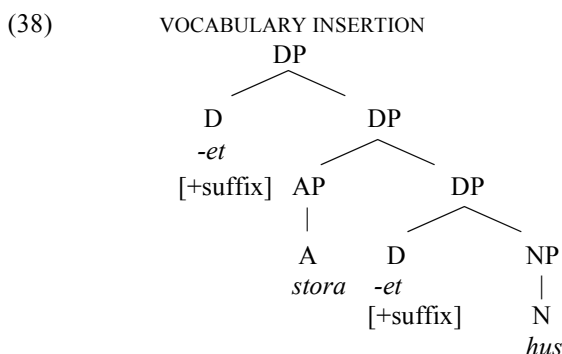

After Vocabulary Insertion, the structure has to be linearized by mapping the hierarchical relations onto a linear ordering. The result of Linearization is the linear string in (39a). After Linearization, Local Dislocation of the lower D-copy takes place. Local Dislocation attaches this copy to the nominal stem, in order to satisfy the suffixal property of the D (39b). This is exactly the same as in the derivation of the unmodified definite DP in (24). Unfortunately, the higher D-copy cannot undergo Local Dislocation to satisfy its suffixal requirements. Local Dislocation can only affect linearly adjacent elements (Embick & Noyer 2001, see the discussion above in section 3.1). Therefore, the higher D-copy can only undergo Local Dislocation to the adjective. However, D is a nominal suffix and cannot be hosted by an adjective. The suffixal properties of the higher D thus need to be satisfied in a different way. As a last resort measure, a dummy host, *d-* is inserted (cf. the *d*-support in Santelmann 1993 & Roehrs 2006) (39c). This insertion is the same

²⁸ In chapter 4, I also propose that not only definite DPs are derived in this way, but also indefinite DPs. However, I will claim that the indefinite article is not an instance of D, but that D in indefinite DPs is null. This will not only explain the absence of double indefiniteness, but also why adjectives take strong adjectival inflection.

operation as the *d*-insertion with *-ende* nouns (see section 3.1). The purpose of *d*-insertion is the same in both cases: supporting a definite suffix that does not have a suitable host. Finally, the result of this phono-morphological repair is spelled out as in (39d).

- (39) a. LINEARIZATION²⁹
 -et * stora * -et * hus
 [+suffix] [+suffix]
- b. LOCAL DISLOCATION
 -et * stora * * hus + et
 [+suffix]
- 
- c. D-SUPPORT
d+et * stora * hus+et
- d. SPELL-OUT
det stora huset

Normally, only one copy of a chain is spelled out (Pesetsky 1998; Bobaljik 2002; Nunes 2001). However, in the double definiteness construction, both D-copies are spelled out: the higher one as the freestanding definite article and the lower one as the definite suffix. Pesetsky (1998) and Nunes (2001) attribute the non-pronunciation of copies to the mechanism of Chain Reduction, which normally deletes all but one copy. Nunes (2001) argues that there is however one exception to this. He proposes that copies that are morphologically reanalyzed as part of a larger word are invisible for Chain Reduction. This invisibility through morphological reanalysis ensures the double spell-out of D in the case of double definiteness. I claimed above that the lower D-copy undergoes Local Dislocation to adjoin to the right of the nominal root. The result of this Local Dislocation is that the lower D is morphologically reanalyzed as part of the head noun. Therefore, it becomes invisible for Chain Reduction. As a result, Chain Reduction will only see the higher D-copy. Because Chain Reduction only applies to chains of more than one copy, it will leave the higher D-copy unaffected. Hence, the combination of the Local Dislocation of the lower D-copy and the invisibility of morphologically reanalysed constituents for Chain Reduction ensures that both copies of D are spelled out in double definiteness.

3.3.5. A note on Chain Reduction and the ordering of operations

It is crucial for the analysis proposed here that Chain Reduction takes place after Local Dislocation. Otherwise, Chain Reduction would delete the lower D, before it becomes a suffix on N. However, this is at odds with the analysis proposed in Nunes (2001), who proposes that Chain Reduction takes place before Linearization. As Local Dislocation operates on linearized structures, this would mean that Chain

²⁹ The ‘*’ sign marks precedence and adjacency, see section 3.1.

Reduction also takes place before Local Dislocation. I argue here that Nunes' proposal is wrong and that Chain Reduction should take place after Linearization.

The reason for which Nunes (2001) proposes that Chain Reduction precedes Linearization is that otherwise Linearization of syntactic structures that contain a chain will result in contradictory linearization statements. Consider for instance the chain $\langle X, X \rangle$ resulting from movement of X over another element Y, in (40).

(40) ...[X_i [Y [X_i...]]]

If (40) is linearized, X will both have to precede and follow Y, which is a contradictory statement. Applying Chain Reduction before Linearization will avoid these contradictory statements from being generated. Note, however, that this reasoning involves a form of look-ahead. Chain Reduction has to take place first, because otherwise things go wrong during Linearization, the next step in the computation.

Under the analysis proposed here, Chain Reduction applies after Linearization as a sort of repair mechanism. Linearization is nothing more than the translation of a hierarchical syntactic structure to a linear sequence. It applies blindly without caring whether it generates contradictory statements. If the outcome of Linearization contains a contradictory statement because of the presence of a chain, Chain Reduction will repair it later on before the actual phonological interpretation takes place. In this way, the look-ahead associated with Chain Reduction under Nunes' analysis is avoided.³⁰

Note that, in the analysis proposed here, Chain Reduction does not only take place after Linearization, but also after Local Dislocation. However, Chain Reduction will have to take place before Phonological Spell-out, the point in the computation at which the linearized sequence of Vocabulary Items is interpreted phonologically. If a contradictory linearization statement will reach the point of Phonological Spell-out, the derivation will crash. I do not see any reason why the operations between Linearization and Phonological Spell-out should be ordered intrinsically. Below in section 5.2, I will argue that languages can actually choose in which order these operations apply. Different orders yield cross-linguistic differences. As mentioned above, I take Local Dislocation to take place prior to Chain Reduction in Swedish. This yields the doubling of the definite article. I will however argue that in Danish, contrary to Swedish, Local Dislocation takes place after Chain Reduction. This yields the absence of definite article doubling in Danish.

3.4. Summary

Above, I introduced my analysis of double definiteness. I claimed that the attributive adjectives are adjoined to DP. This explains the fact that their inflection is sensitive to the definiteness of the DP. Adjoining the adjective to DP has the downside that it

³⁰ As pointed out to me by Lisa Cheng (personal communication), it is crucial for this proposal that chains are still represented in some manner after linearization. I will leave the exploration of the consequences of this to further research.

puts the AP outside the scope of the D. In addition, it creates a type mismatch. The type mismatch triggers internal merge of D at a position that c-commands both the AP as the lower D-copy. At the CI-interface, the lower D-copy is deleted. In this way, the type mismatch is resolved. The internal merge of D and the subsequent deletion of the lower D copy also ensure that the adjective is interpreted in the scope of D. The morphological component ensures that both D-copies are spelled out. Local Dislocation saves the lower D-copy from deletion through Chain Reduction.

Double definiteness is therefore the result of an intricate interaction between the morphological and the syntactic components of the grammar. In the syntactic component, a structure containing two Ds is generated. Processes in the morphological component subsequently ensure that the two Ds are spelled out. In the following section, I will examine how the analysis accounts for the distribution of double definiteness.

4. The distribution of double definiteness

In the previous section, I introduced my analysis of double definiteness in DPs with a pronominal adjective in Swedish, Norwegian, and Faroese. In these languages, the presence of a pronominal adjective is however neither a necessary nor a sufficient condition for double definiteness. On the one hand, there are definite DPs that do not contain an adjective, but still display double definiteness. On the other hand, there are definite DPs that contain pronominal adjectives, but do not display double definiteness. In this section, I examine how my analysis of double definiteness accounts for the distribution of double definiteness. As in the previous sections, the discussion is mainly centered on Swedish, but most of it directly carries over to Faroese and Norwegian.

First, I examine two contexts in which double definiteness is triggered in the absence of a pronominal adjective: definite DPs containing a numeral or weak quantifier and DPs in which the definite article receives a demonstrative reading. Second, I take a closer look at a variety of definite DPs in which double definiteness is impossible even in the presence of a pronominal adjective. In the first two cases, *denna*-type demonstratives and pronominal possessive pronouns, the absence of double definiteness is the result of D being non-suffixal. In the other cases, other properties of DP are responsible for the absence of double definiteness. Finally, I discuss definite DPs containing relative clauses.

4.1. Double definiteness without a pronominal adjective

In my analysis of double definiteness, pronominal adjectives play a crucial role. They cause a type mismatch that triggers internal merge of D. In this way, they license a DP with two Ds. From this perspective, it is rather surprising that there are DPs without pronominal adjectives that display double definiteness. There are two cases. First, the presence of a numeral or a weak quantifier like *many* in a definite

DP triggers obligatorily double definiteness (Julien 2005; Santelmann 1993; Holmes & Hincliffe 1994). This is illustrated in (41).

- (41) *de många/tre bil-ar-na* [Swedish]
 the many/three car-PL-DEF
 ‘the many/three cars’ (Santelmann 1993: 156)

Second, the definite article can receive a demonstrative/contrastive interpretation (Julien 2005; Santelmann 1993; Holmes & Hincliffe 1994). In that case, double definiteness occurs even if the DP lacks a prenominal adjective (42). The freestanding definite article is stressed in this case (see Bernstein 1997: 91) and it is optionally accompanied by the proximate prepositional pronoun *här* ‘here’, as in the second half of example (42a) and in (42b), or by the distal prepositional pronoun *där* ‘there’ (42c).

- (42) a. *den film-en var rolig,* [Swedish]
 the.NON-NEUTER film-DEF.NON-NEUTER was funny
men den här film-en var tråkig
 but the.NON-NEUTER here film-DEF.NON-NEUTER was dull
 ‘that film was funny, but this film was dull’
 b. *den här bil-en*
 the.NON-NEUTER here car-DEF.NON-NEUTER
 ‘This car’
 c. *den där bil-en*
 the.NON-NEUTER there car-DEF.NON-NEUTER
 ‘That car’ (Santelmann 1993: 156)

Both in (41) and in (42), there is no prenominal adjective to cause a type mismatch and hence to trigger internal merge of D. Given the central role of the adjective in my analysis, the question is therefore how double definiteness comes about in these cases.

Below, I show that the double definiteness in DPs containing a numeral or weak quantifier, as in (41), is almost identical to double definiteness in DPs that contain a prenominal adjective. However, the double definiteness in (42) is of a different kind. It is not triggered by a type mismatch, but by the need to license a feature associated to the demonstrative interpretation of D. I will now discuss in detail how these two cases of double definiteness in definite DPs can be dealt with in my analysis.

4.1.1. DPs with numerals and weak quantifiers

As illustrated above in (41), weak quantifiers and numerals in definite DPs trigger double definiteness. Here, I argue that the only difference that set these instances of double definiteness apart from those involving a DP containing a prenominal adjective is the element that causes the type mismatch.

First, it is important to notice that numerals and weak quantifiers are in a position that is to the left of adjectives, as can be seen in (43).

- (43) *dei to/mange (gul-e) skjort-e-ne* [Norwegian]
 the.PL two/many yellow-WEAK shirt-PL-DEF
 ‘the two/many/yellow shirts’ (Julien 2005: 26)

On the assumption that *to the left* means the same as *structurally higher* (as is for instance the case in Kayne’s (1994) LCA), I conclude from this observation that numerals and weak quantifiers are structurally higher than adjectives. As I have shown in section 3.3, there are good reasons to believe that adjectives are adjoined to DP. Therefore, adjectives are merged outside the scope of the definite D. Given that numerals and weak quantifiers are higher in the syntactic structure than attributive adjectives, I conclude here that they are also merged outside the scope of a definite D (44).³¹

- (44) NUMERALS/WEAK QUANTIFIERS > (ADJECTIVES >) DEFINITENESS

For numerals and weak quantifiers, this is as problematic as for attributive adjectives. Merge of a numeral or weak quantifier in a position that is higher than D causes a type mismatch. Numerals and weak quantifiers are of the Generalized Quantifier semantic type, $\langle\langle e,t\rangle, \langle\langle e,t\rangle,t\rangle\rangle$ (see among others Heim & Kratzer 1998: 146). This means that they have to take a predicative (type $\langle e,t\rangle$) complement. However, if their complement is a definite DP, their complement is referential and therefore of type $\langle e\rangle$, not of type $\langle e,t\rangle$ (see also fn. 25). Hence, the merger of numerals and weak quantifiers leads to a type mismatch, just like the adjunction of attributive adjectives. This is shown in (45) for (43).

- (45)
-

In this case, the same repair strategy is used as with the adjectives. The definite D is copied and merged with the already existing structure (46a). At the CI-interface, the higher copy is interpreted. This resolves the type mismatch. Furthermore, it puts the numeral or weak quantifier in the scope of the definite D (46b). In the

³¹ With adjectives, there were syntactic reasons why they should be adjoined outside the domain of D (a conspiracy by the No Tampering Condition, the phasehood of DP, and late adjunction). For numeral and weak quantifiers, I cannot think of any reasons as to why they are originally merged outside the scope of the definite determiner. However, their occurrence to the left of the adjectives strongly suggests that they are.

morphological component, the lower D undergoes Local Dislocation. This operation has as a consequence that the lower copy becomes invisible for Chain Reduction (46c). Hence, both copies of D are spelled out, yielding the surface effect of double definiteness (46d).

(46) a. INTERNAL MERGE D

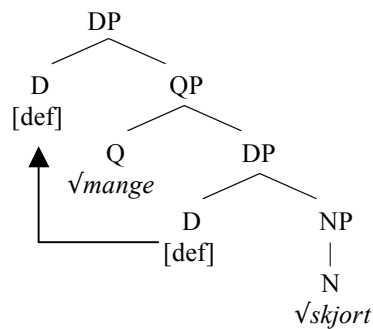

b. CI-INTERFACE : INTERPRET HIGHER D-COPY

$[_{DP} D [_{QP} Q [_{DP} D [_{NP} N]]]]$

c. MORPHOLOGICAL COMPONENT :

VOCABULARY INSERTION/LINEARIZATION/LOCAL DISLOCATION

*d-ei * mange * * skjort-e-ne*

d. *dei mange skjortene*

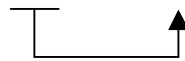

The derivation of definite DPs with a weak quantifier or numeral is hence almost identical to the derivation of definite DPs with a prenominal adjective. In both cases, a type mismatch triggers internal merge of D. This eventually leads to double marking of definiteness. The only difference is the element that causes the type mismatch: a numeral or weak quantifier instead of a prenominal adjective. I will now turn to the cases in which double definiteness is triggered through the demonstrative interpretation of the definite article.

4.1.2. The demonstrative use of the definite article

The second case of double definiteness without an attributive adjective concerns DPs in which the freestanding definite article receives a demonstrative or contrastive reading. The relevant example was (42), which is reproduced below as (47). Recall that the freestanding definite article is stressed in this case and is optionally accompanied by *här* 'here' or *där* 'there'

- (47) a. *den film-en var rolig,* [Swedish]
 the.NON-NEUTER film-DEF.NON-NEUTER was funny
men den här film-en var tråkig
 but the.NON-NEUTER here film-DEF was dull
 ‘that film was funny, but this film was dull’
- b. *den här bil-en*
 the.NON-NEUTER here car-DEF.NON-NEUTER
 ‘This car’
- c. *den där bil-en*
 the.NON-NEUTER there car-DEF.NON-NEUTER
 ‘That car’ (Santelmann 1993: 156)

In this case, double definiteness is not triggered through a type mismatch. This becomes clear if one considers the first DP displaying double definiteness in (47a): *den filmen* ‘that film’. In this DP, there is no extra material except for the emphatic free definite article, the noun, and the definite suffix. Hence, there is also no element that can cause a type mismatch.³² However, if it is not triggered by a type mismatch, what triggers double definiteness in these cases?

The freestanding article in (47) differs from the freestanding article in the other instances of double definiteness in a crucial way: it gives the DP a contrastive interpretation. The DPs in (47a), *den filmen* ‘this film’ and *den här filmen* ‘that film’, are overtly contrastive with respect to each other. In (47b,c), the presence of distal *här* and proximate *där* signals the presence of alternative set of cars with which the DPs in (47b,c) contrast. I claim that this contrastive interpretation is the trigger of the double definiteness.

In the case of unmodified definite DPs without a contrastive interpretation, the D has only interpretable definiteness features (see section 3.2). Once this definite D is merged with NP, all the features of the D are licensed and there is no need for the D to undergo additional movement in Narrow Syntax. In the case of (47), I will assume that the contrastive interpretation of the DP is due to an uninterpretable contrastive focus feature of D.³³ Following Aboh (2004), I will assume that DPs have a left-periphery in which features can be checked that are related to the discourse status of elements contained in the DP in question (like topic and focus). Merging D with NP does not check D’s uninterpretable contrastive focus feature (48a).³⁴ Following Aboh (2004) idea of a left periphery for the nominal domain, this

³² David Pesetsky (personal communication) points out to me that there is a potential alternative analysis, according to which a type mismatch is the cause of double definiteness in (47). He suggests that *den filmen* in (47a) contains a null counterpart of a locative modifier, similar to the overt *här* ‘here’ and *där* ‘there’ in (47) and that this null counterpart causes a type mismatch resulting in double definiteness in a similar way as with adjectives. This alternative analysis has the benefit of uniforming the trigger for double definiteness. Due to time restrictions, I cannot explore this alternative analysis in full detail here. Note however that if one were to pursue this analysis for the facts in (47a), one would like to have an independent argument for a null locative modifier in *den filmen* in (47a).

³³ Thanks to Anikó Lipták (personal communication) for pointing out that the relevant discourse property is contrastive focus in this case.

³⁴ In (48), ‘*i*’ stands for interpretable, ‘*u*’ stands for uninterpretable, and ‘[contr.foc]’ indicates a contrastive focus feature. Strikethrough of a feature indicates checking, while strikethrough of elements at the CI-interface indicates deletion. Note that I used feature checking (Chomsky 1995) for the licensing of

has to be done in a dedicated focus projection in the nominal left-periphery, FocP.³⁵ Therefore, the D is copied and merged with the head of FocP. This merger permits D to check its uninterpretable contrastive focus feature, (48b). Subsequently, the structure is submitted to the CI and SM-interfaces. At the CI-interface, the higher copy is interpreted, because the contrastive focus feature is checked in the higher copy, not in the lower one (48c). In the morphological component, the vocabulary items are inserted and linearized (48d). The checked contrastive focus feature on the higher copy will be realized through stress. As in the other double definiteness cases that I discussed above, the lower D will undergo Local Dislocation and right-adjoin to the noun in order to satisfy its suffix properties (48e). After this application of Local Dislocation, the higher D will be supported by the dummy host *d-* in order to satisfy its suffixal requirements (48f) and the structure will be phonologically spelled out.

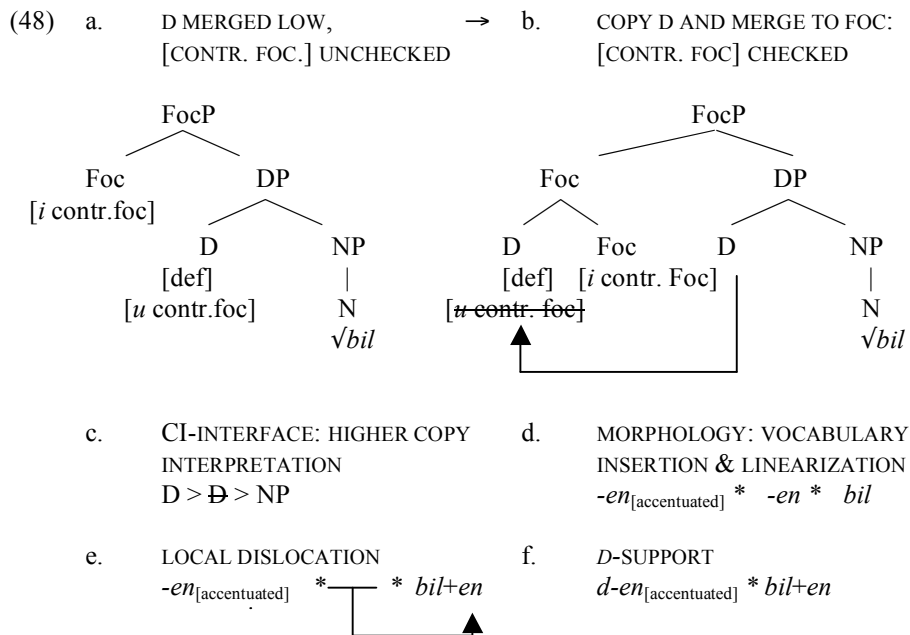

As with definite DPs containing an adjective, the morphological reanalysis caused by Local Dislocation ensures that the lower copy becomes invisible for Chain Reduction. This has the effect that both copies are spelled out. Another effect of the Local Dislocation operation in (48e) is that the higher copy ends up adjacent to the noun (49). Potentially, this creates a new environment in which Local Dislocation

contrastive focus on D, instead of the Agree-relation. The reason for this is that I am not sure whether Agree can be applied to the licensing of discourse properties, because it looks like that it involves a Probe, the focus or topic, that seems to be c-commanded by the Goal, the Foc or Top-head, instead of the Probe c-commanding the Goal.

³⁵ FocP assigns contrastive focus status to elements inside the nominal domain. It does not turn the entire nominal domain into a focus.

could take place. However, if the higher copy were locally dislocated in this case, it would have to right-adjoin to the lower copy of D, as in (49b). This would result in a sequence in which the nominal root is followed twice by the same suffix.

- (49) a. $-en$ * $bil + en$
 b. WRONG LOCAL DISLOCATION
 $\underline{\quad}$ * $bil + en + en$
- 

I propose that a haplology rule blocks Local Dislocation if it results in a repetition of the same suffix on a word. Therefore, the higher D copy cannot undergo Local Dislocation and, as a consequence, it will have to satisfy its suffixal properties through the insertion of the dummy *d*-host.

The double definiteness that occurs in definite DPs in which the definite article licenses a contrastive/demonstrative DPs is thus of a different kind than the other instances of double definiteness. The internal merge of D is not triggered in this case by a type mismatch, but in order to license a contrastive interpretation of D. Except for having a different trigger for internal merge, the derivation of the definite DPs discussed here is the same as the derivation of those with prenominal adjectives, numerals, or weak quantifiers.

Up till now, I showed how my analysis accounts for the occurrence of double definiteness. However, double definiteness is also absent in some cases, where it would at first sight be expected. I will now turn to these cases.

4.2. Definite DPs with adjectives, but without double definiteness

As I indicated above, the presence of a prenominal adjective in a definite DP is not a necessary condition for the occurrence of double definiteness. In this section, I will discuss a variety of definite DPs that do not display double definiteness, even when they contain a prenominal adjective. I will show that for most of these cases the absence of double definiteness readily follows from my analysis.

I will first discuss demonstrative DPs introduced by the *denna*-type demonstrative determiner and DPs that contain prenominal possessive pronouns. In these cases, the absence of double definiteness is predicted under the current analysis, since D is not suffixal. The next case I discuss includes proper names and DPs that pattern with proper names. Finally, I will address some cases in which DP is non-referential.

4.2.1. DPs with a non-suffixal D

The suffixal character of the Swedish definite article plays an essential part in the analysis of double definiteness presented in section 3 above. This suffixal character triggers Local Dislocation of the lower copy of the definite article to N. In DPs that contain an adjective, this results in the lower D-copy becoming invisible for Chain Reduction. This is the cause for the double spell-out of the definite article.

$$(51) \quad [D_{[dem]} [AP [DP D_{[dem]} [N NP]]]]$$

However, the derivation of DPs containing a *denna*-demonstrative determiner is different in the morphological component. Instead of the definite article, Vocabulary Insertion inserts *denna* in the two D-positions. In the case at hand, we expect that double definiteness would take the form of a doubling of *denna*. However, this is excluded (52).

$$(52) \quad *denna \quad mörk-a \quad denna \quad skog$$

this.NON-NEUTER dark-WEAK this.NON-NEUTER wood

The absence of a double marking of definiteness with *denna*-type demonstratives is the result of the morphological properties of the *denna*-determiner. *Denna* is not a suffix. Therefore, as pointed out above, Local Dislocation is not triggered after Vocabulary Insertion. For this reason, the lower copy of *denna* is still visible when Chain Reduction applies. Chain Reduction therefore deletes the lower copy of *denna*, as in (53). This deletion bleeds a double spell-out of the *denna* determiner.

$$(53) \quad \text{CHAIN REDUCTION}$$

$$denna * mörk-a * ~~denna~~ * skog$$

In this way, it is their status as free morphemes that prevents the *denna*-type demonstrative determiners from being spelled out twice. As noted above, the absence of doubling with non-suffixal Ds is an important prediction of my analysis of double definiteness. As a consequence, the absence of double definiteness with *denna*-type demonstratives constitutes additional support for my analysis.

4.2.1.2 Prenominal possessors

DPs introduced by prenominal possessive pronouns are another instance of definite DPs in which double definiteness does not occur because the element in D is not a suffix. As noted by Giusti (1994) and Santelmann (1993), there is no double definiteness with prenominal possessive pronouns, as is illustrated in (54).³⁸ The only marker of definiteness in (54) is the prenominal possessive pronoun *min* ‘my’, regardless of whether it is followed by an adjective or not.

$$(54) \quad a. \quad \mathbf{min} \quad \mathbf{bil} \quad \text{[Swedish]}$$

my car

³⁸ Although the presence of a prenominal possessive pronoun or phrase renders the DP definite in Germanic, this is not a universal property of human languages. In many languages, prenominal possessives can occur both in definite and indefinite DPs, as for instance in Italian and Bulgarian (see for instance Schoorlemmer 1998 and Cardinaletti 1998 for discussion).

- b. *min stor-a bil*
 my big-WEAK car
 'My/Karin's big car' (Santelmann 1993: 157-158)

The absence of the double definiteness in this case can be explained in the same way as its absence with the *denna*-type demonstrative above.³⁹

I follow Delsing's (1998) proposal that possessive pronouns are heads. More specifically, I will assume that they are instances of D.⁴⁰ The syntactic derivation of (54b) is identical to those of the other definite DPs containing an adjective. Hence, the result of the derivation is as in (55): a DP with two Ds.

- (55) [D_[def] [AP [DP D_[def] [N NP]]]]

In the morphological component, Vocabulary Insertion inserts the possessive pronoun in both Ds, (56a). The possessive pronoun is a free morpheme, just like the *denna*-type demonstrative determiner. It will therefore not undergo Local Dislocation. This makes the lower copy of the possessive pronoun visible for Chain Reduction. As a result, Chain Reduction will delete the lower copy, as in (56b).

- (56) a. VOCABULARY INSERTION & LINEARIZATION
*min * stora * min * bil*
- b. CHAIN REDUCTION
*min * stora * ~~min~~ * bil*
- c. PHONOLOGICAL SPELL OUT
min stora bil

Possessive pronouns thus constitute another example that the core prediction of my analysis that non-suffixal Ds do not trigger double definiteness is borne out.

³⁹ Northern Swedish dialects and Norwegian also permit the possessive pronoun to follow the head noun (Delsing 1998:87). In that case, the head noun carries the definite suffix, as in (ia). Given the fact that both the possessive pronoun and the definite suffix mark the DP as definite, this is a form of double definiteness. In these varieties, the opposite order, i.e. the one in which the possessive pronoun occurs before the noun, is also permitted. However, in that case, as in the instances of standard Swedish discussed in the text, there is no definite suffix on the noun (i)

- (i) a. *hus-et mi-tt* [Norwegian]
 House-DEF.SG.NEUTER my-SG.NEUTER
- b. *mi-tt hus*
 my-SG.NEUTER house
 'my house' Delsing (1993: 87)

At present, I do not have an explanation of this pattern. Further research will have to determine how these data can be accounted for.

⁴⁰ The assumption that possessive pronouns are Ds differs slightly from Delsing's (1998) proposal. According to him, they start out as heads of a separate projection PosP, which is situated immediately below D. They then undergo head movement to D. The analysis presented here also works under Delsing's original proposal. I just assume that possessive pronouns are Ds in order to simplify the current discussion.

In Swedish, prenominal possessors can also be non-pronominal. In that case, the possessor is marked with the genitive *-s*. This is illustrated in (57), where the possessor *Karin* takes the genitive *-s* ending.

- (57) *Karin-s bil*
 Karin-GEN car
 ‘Karin’s car’ (Santelmann 1993: 157 158)

Just like the prenominal possessive pronouns above, these prenominal genitive possessors mark the DP as definite. This is similar to English in which *John’s bike* can be paraphrased as *the bike of John* but not as *a bike of John* (see Haspelmath 1999).⁴¹ Like their pronominal counterparts, prenominal genitive possessors do not license any form of double definiteness, not in case of an unmodified DP (57), nor when the DP contains a prenominal adjective as in (58). The only way definiteness is marked in these cases is through the presence of the prenominal possessor.

- (58) *Karins stora bil* [Swedish]
 Karin-GEN big-WEAK car
 ‘Karin’s big car’

Unfortunately, this absence of double definiteness cannot be explained in the same way as the absence in DPs with prenominal possessive pronouns. The reason for this is that the prenominal genitive possessors are not heads. Instead, they are maximal projections of their own, as is shown by the fact that even complex DPs can be prenominal genitive possessors (59).

- (59) [*mann-en på gata-n-s*] *åsikter*
 man-DEF.NON-NEUTER.SG on street-DEF.NON-NEUTER.SG-GEN views
 ‘the views of the common man’ (Delsing 1998: 97)

If they are not heads, genitive possessors are not instances of D. However, this makes it unclear how the definite reading of DPs like (57) comes about. That matter should be resolved first before one tries to account for the absence of double definiteness. However, a detailed study into the licensing of definiteness in DPs with prenominal genitive possessors is outside the scope of the present chapter. For this reason, I will have to leave the absence of double definiteness in (58) unexplained in this thesis.⁴²

⁴¹ Yves d’Hulst (personal communication) points out to me that it is the definiteness of the prenominal possessor that determines the definiteness of the DP in which this possessor is contained. In *John’s bike*, *John*, being a proper name, is definite and so is the DP *John’s bike*. In *a man’s friend*, the possessor is indefinite (*a man*) and so is the entire DP; *a man’s friend* has the same reading as *a friend of a man*.

⁴² David Pesetsky (personal communication) suggests that the genitive *-s* in (58) could be analyzed as the spell-out of a non-suffixal D (along the lines of the proposal of Abney (1987) for the saxon genitive *-s*) while the possessor occurs in Spec DP. In that case, the non-suffixal character of the genitive *-s* inserted in D, would explain why it is not doubled, just like with the *denna*-type demonstrative determiner or the possessive pronouns.

4.2.2. Proper names

I will now turn to a case of a definite DP with a prenominal adjective in which double definiteness does not occur, but which cannot be attributed to the non-suffixal character of D: certain proper names. Julien (2005), Delsing (1993), Börjars (1996) and Santelmann (1993) observe that prenominal adjectives that are part of a proper name do not trigger double definiteness. This is illustrated in (60), which is taken from Börjars (1996: 203, ex 5.87).

- (60) a. *Svensk-a* *Dagbladet*
 Swedish-WEAK daily-DEF.SG.NEUTER
 ‘Svenska Dagbladet’ (the name of a newspaper)
- b. *Vita* *huset*
 white-WEAK house-DEF.SG.NEUTER
 ‘The White House’ (the name of the home of the American President)
- c. *Svarte* *havet*
 black-WEAK sea-DEF.SG.NEUTER
 ‘The Black Sea’ (the name of a sea in South-Eastern Europe)

The DPs in (60) are definite and contain a prenominal adjective. However, definiteness is only marked by the definite suffix. The freestanding definite article is not present in (60).

Börjars (1996: 205) argues that the noun and the adjective in each of the examples in (60) form one single vocabulary item. According to Börjars, this is supported by the observation that it is impossible to add other adjectives in between the nouns and adjectives in (60). This is shown in (61). Furthermore, Börjars shows that the ungrammaticality of the DPs in (61) is not due to a general ban on the occurrence of the adjectives *fallfärdiga* ‘ramshackle’ and *vältryckta* ‘well printed’ in the position between adjectives like *vita* ‘white’ and *svenska* ‘Swedish’ and the noun. This is shown in (62). Finally, the ungrammaticality of the DPs in (61) is also not caused by a general ban on the modification of the DPs in (60). Additional adjectives can be added as long as they are inserted to the left of the adjectives in (60) and are preceded by the freestanding definite article, as in (63). The examples in (61)- (63) are all taken from Börjars (1996: 205).

- (61) a. * *Vit-a* *fallfärdig-a* *hus-et* [Swedish]
 white-WEAK ramshackle-WEAK house-DEF.SG.NEUTER
 ‘The ramshackle White House’

An analysis along these lines, however, suffers from an important drawback. It cannot explain why the possessor precedes the adjective in DPs like (58). The fact that the possessor precedes the adjective suggests that it is in the specifier of the higher D copy. Whatever property causes the possessor DP to occur in Spec DP should, however, be satisfied already in the lower DP layer prior to internal merge of D triggered by adjunction of the adjective. Under this analysis, the presence of possessor in Spec DP of the lower D-copy is therefore a mystery. I will therefore not pursue an analysis along these lines here.

- b. * *Svensk-a vältryckt-a Dagbladet*
 Swedish-WEAK well-printed-WEAK daily
 ‘The well-printed Svenska Dagbladet’
- (62) a. *vita fallfärdig-a hus* [Swedish]
 white-PL ramshackle-PL house
 ‘white ramshackle houses’
- b. *svensk-a vältryckt-a böck-er*
 Swedish-PL well-printed-PL book-PL
 ‘well-printed Swedish books’
- (63) a. * (*det fallfärdig-a Vita huset*) [Swedish]
 DEF.NEUTER.SG ramshackle-WEAK white-WEAK house-DEF.SG.NEUT
 ‘the ramshackle White House’
- b. * (*det vältryckt-a Svensk-a Dagbladet*)
 DEF.NEUTER.SG well-printed-WEAK Swedish-WEAK daily
 ‘the well-printed Svenska Dagbladet’

The fact that the adjectives and nouns in (60) form proper names together offers a straightforward explanation for the absence of the freestanding definite article. In my analysis, the freestanding definite article is licensed as the result of the adjunction of an adjective to DP. However, if the adjective *vita* ‘white’ and the noun *huset* ‘the house’ (60b) form a single vocabulary item, then they are not combined in the syntactic component. Instead, they are inserted in the morphological component as one unit in a single terminal syntactic head. Hence, there is no adjunction of an AP to DP in (60). As a consequence, the freestanding definite article is not triggered and double definiteness does not arise.

In addition to definite DPs with a prenominal adjective that are obviously proper names, the freestanding definite article can be omitted in some other cases as well, like in (64) (Delsing 1993, Julien 2005).

- (64) *Ta (den) nya bil-en* [Swedish]
 Take DEF.SG.NON-NEUTER new-WEAK car-DEF.SG.NEUTER
 ‘Take the new car’ (Delsing 1993: 118)

According to Delsing (1993) and Julien (2005), the omission of the freestanding definite article is only possible when the referent of the definite DP is strongly familiar, i.e. the uniqueness of the referent is presupposed by both the speaker and the hearer. For this reason, Delsing (1993) and Julien (2005) conclude that the omission of the free definite article causes a reading that is similar to that of a proper name. I would like to suggest that this is caused by the fact that the adjective and the noun in (64) syntactically function together as a proper name when the freestanding definite article is omitted. In that way, the omission of the free definite article in (64) receives the same explanation as that in (60).⁴³

⁴³ There is some variation among the languages that display double definiteness with respect to the possibility of omitting the definite article in the described discourse context. Julien (2005: 33) reports that

When an adjectival modifier is added to a DP containing a proper name, the freestanding definite article is required. This is not only the case when an additional adjective modifies a proper name that itself consists of an adjective and a noun, as in (63) above, but also with other proper names. This is illustrated in (65) for the place name *Roma* ‘Rome’.

- (65) **(Det) gaml-e Roma vart øydelagt* [Norwegian]
 DEF.NEUTER.SG old-WEAK Rome became destroyed
av barbar-a-ne.
 by barbarian-PL-DEF
 ‘Ancient Rome was destroyed by the barbarians’ (Julien 2005: 15)

The occurrence of the freestanding definite article in (63) and (65) is not surprising under my analysis. Proper names are definite DPs. Because vocabulary items are only inserted in the post-syntactic morphological component, the derivation does not know in the syntactic component of the grammar whether a common noun or a proper name will be inserted later on. Hence, the syntactic derivation of a definite DP is the same for proper names and common nouns. Modification by an attributive adjective thus takes place in the same way with proper names as with other definite DPs, i.e. through adjunction of the adjective to the definite DP (see section 3.3). The type mismatch that is caused by this adjunction triggers internal merge of D. Put differently, the syntactic structure that is submitted to the morphological component is the same for modified proper names as for regular definite DPs with a prenominal adjective (66).

- (66) $[D_{[def]} [AP [DP D_{[def]} [N NP]]]]$

Longobardi (1994, 2001, 2006) argues that proper names in Germanic are in N, while D generally remains unpronounced with unmodified proper names.⁴⁴ In order to explain this, Longobardi proposes that N is moved to D in the covert part of the syntactic derivation. In the model of the grammar I am assuming here (see section 3.1), it is not clear what such a covert part of the syntactic component would correspond to. As a consequence, I cannot use Longobardi’s explanation in terms of covert movement of N to D for the absence of an overt D with unmodified proper names. Unfortunately I do not have a principled alternative explanation to offer at the moment. For now, I will just assume that that this non-pronunciation of D is due to a morphophonological readjustment rule. This rule deletes the definite article

while speakers of Swedish in general allow for it, speakers of Norwegian display a lot of variation to this respect.

⁴⁴ Some Germanic varieties, especially some Southern varieties of German, do allow for the pronunciation of D with proper names, as in (i)

- (i) *der Helmut* [Southern German variety]
 DEF.SG.MASC.NOM Helmut
 ‘Helmut’

inserted in D in the case that D is followed by a proper name.⁴⁵ For the languages displaying double definiteness, this rule takes the form in (67).⁴⁶ Note, however, that the rule in (67) is purely descriptive. It only describes the fact that proper names occur without the definite suffix. However, it will do for the present purpose, which is explaining the occurrence of the freestanding definite article when an additional adjective is added to a proper name. I hope to give a more principled account for the absence of the definiteness suffix on proper names in future work.⁴⁷

(67) *definite marker* → Ø/_ Proper Name

I now return to the derivation of (65). At Vocabulary Insertion, this derivation starts to differ for proper names. First, Vocabulary Insertion inserts *Roma* in N, the adjective *gamla* ‘old’ in A and the definiteness marker *-et* in both Ds. Subsequent Linearization results in the linear sequence in (68).

(68) *-et * gamla * -et * Roma*

The rule in (67) then deletes the lower copy of *-et* because it is adjacent to a proper name. The higher copy of *-et* is not and hence is not deleted (69).

(69) PROPER NAME READJUSTMENT RULE (67)
*-et * gamla * Ø * Roma*

Finally, the dummy host *d-* is inserted to support *-et* and the derivation is handed over to the phonological component in the form in (70).

(70) PHONOLOGICAL SPELL OUT
det gamla Roma

The presence of the free definite article with proper names that are modified by a pronominal adjective is thus licensed in the same way as with definite common nouns modified by a pronominal adjective. In both instances, the adjunction of the attributive AP to DP triggers the presence of the free definite article. The only difference between proper names and definite common nouns is that the low copy of D is not pronounced with proper names. I attributed this for now to the morphophonological readjustment rule in (67), but I hope to give a more principled account in future work. I will now turn to the final case of definite DPs that contain

⁴⁵ Embick & Marantz (2008) assume that morpho-phonological readjustment rules are also responsible for irregular verb forms.

⁴⁶ The rule in (67) only deletes the phonological content of D. The definite interpretation of D is unaffected by it, ensuring in this way the definite interpretation of proper names.

⁴⁷ Note that it is not an alternative to propose that N is moved to D in overt syntax or that proper names are Ds in the languages displaying double definiteness. If N were in D, the analysis of double definiteness presented in this chapter would predict that the proper name would precede adjectives in languages displaying double definiteness, because of the internal merge of D. This is however contrary to fact.

a prenominal adjective, but yet do not display double definiteness, namely non-referential DPs.

4.2.3. Nonreferential DPs

Delsing (1993) and Julien (2005) report that only the freestanding definite article is used in DPs with a prenominal adjective that are non-referential/intensional. This is illustrated by the Norwegian sentences in (71), taken from Julien (2005: 36). In (71a), *bøllar* ‘brutes’ lacks the definite suffix. According to Julien, this signals that the speaker does not have any particular brutes in mind. If the definite suffix is present, as in (71b), the speaker however refers to particular brutes.⁴⁸

- (71) a. *Dei oppfører seg som dei verst-e bøll-ar*
 they behave 3REFL as DEF.PL worst-WEAK brute-PL
 ‘They behave like the worst brutes.’ [whoever those are]
- b. *Dei oppfører seg som dei verst-e bøll-ar-ne*
 they behave 3REFL as DEF.PL worst-WEAK brute-PL-DEF
 ‘They behave like the worst brutes [and we know who those are]’

The fact that it is introduced by the freestanding definite article seems to suggest that the DP *dei verste bøllar* ‘the worst brutes’ in (71a) is definite. In that case, it would be another instance of a definite DP containing a prenominal adjective that does not display double definiteness. The absence of double definiteness (71) should then be explained by the analysis proposed here.

However, Delsing (1993: 128-129) observes that DPs with the freestanding definite article but no definite suffix can occur in existential contexts, like in (72). In (72a), *prinsessa* ‘princess’ does not take a definite suffix and it occurs in an existential context. However, if *prinsessa* ‘princess’ occurs with the definite suffix, it cannot occur in an existential context, (72b).⁴⁹

⁴⁸ The contrast between (71a) and (71b) might not be as clear cut as presented in Julien (2005). At least one native speaker (Kristine Bentzen, personal communication), reports that the non-referential reading is not only possible in (71a), but also in (71b), rendering (71b) ambiguous between a referential and a non-referential reading. Her judgements are the same for the pair of sentences in (i), the DP without the definite suffix in (1a) being only non-referential, while its counterpart with the definite suffix in (ib) is ambiguous between a non-referential and non-referential reading.

- (i) a. *Jeg ser etter de verste bøll-er i hæren (til en ny film jeg lager)*
 I look after DEF.PL worst-WEAK brutes-PL in army-DEF to a new film I make
- b. *Jeg ser etter de verste bøll-ene i hæren (til en ny film jeg lager)*
 I look after DEF.PL worst-weak brutes-PL.DEF in army-DEF to a new film I make
 ‘I look for the worst brutes in the army (for a new film I am making)’

Note that that there are orthographic differences between the sentences in (i) and the ones in (71). This is due to the different written standards that are used for Norwegian. (71) is written in the Nynorsk, (i) in Bokmål.

⁴⁹ In addition, note that the freestanding determiner can only occur in (72) if the adjective is a superlative. If the adjective is not a superlative, the sentence becomes ungrammatical, as in (i).

- (72) a. *det sitter den vackrast-e* [Swedish]
 there sit DEF.SG.NON-NEUTER prettiest-WEAK
prinsessa i torn-et
 princess in tower-DEF.SG.NEUTER
- b. **det sitter den vackraste*
 there sit DEF.SG.NON-NEUTER prettiest-WEAK
prinsessa-n i torn-et
 princess-DEF.SG.NON-NEUTER in tower-DEF.SG.NEUTER
 ‘there is a most beautiful princess sitting in the tower’

Definite DPs are normally banned from occurring in existential contexts, cf. **there is the pool in the garden*.⁵⁰ Therefore, Delsing concludes that DPs like *den vackraste prinsessa* ‘the most beautiful princess’ in (72a) are not definite. If they are not definite, they are not problematic for my analysis of double definiteness. My analysis of double definiteness is built on the idea that a definite D is internally merged in syntax. If DPs like those in (71a) and (72a) are not definite, then they do not contain a definite D. Hence, the absence of double definiteness is unsurprising. Although the question of why the freestanding definite article occurs in (71a) and (72a) is interesting in its own right, it is not directly related to double definiteness. I will therefore not try to answer this question here.

4.3. A note on relative clauses

Above I discussed the distribution of double definiteness. I first showed how my analysis accounts for cases in which double definiteness arises in the absence of a prenominal adjective. I then discussed some cases in which double definiteness does not occur where it is expected, because of the definiteness of the DP and the presence of a prenominal adjective. However, until now, I did not discuss DPs with relative clauses. Relative clauses influence the way in which definiteness is marked in interesting ways.

-
- (i) **det sitter den vackr-a prinsessa i torn-et*
 there sit DEF.SG.NON-NEUTER pretty-WEAK princess in tower-DEF.SG.NEUTER
 ‘there is the/a beautiful princess in the the tower’ (Julien 2005: 41)

This seems to strongly suggest that the freestanding definite article is licensed somehow by the superlative. Note that superlatives can in some languages license a definite article on their own, as for instance in French (ii). See Julien (2005) for further discussion of this observation.

- (ii) *la voiture la plus belle*
 the car the most beautiful
 ‘the most beautiful car’

This seems to further support that the DPs (71a) and (72a) are not definite. It might even be the case that the freestanding definite article is part of the adjectival domain and not part of the nominal domain.

⁵⁰ See however Ward & Birner (1995) for a different view.

First, non-restrictive relative clauses do not influence the way definiteness is marked. In the presence of a non-restrictive relative clause, the noun takes the definite suffix, as in (73) (Hankamer & Mikkelsen 2005; Julien 2005).⁵¹

- (73) *mus-en* *som vi såg* [Swedish]
 mouse-DEF.SG-NON-NEUTER that we saw
 ‘the mouse, which we saw’ (Hankamer & Mikkelsen 2005: 108)

Restrictive relative clauses on the other hand can influence the definiteness marking on the noun in different ways (Hankamer & Mikkelsen 2005, Julien 2005, see also Holmberg 1993). First, they sometimes can trigger double definiteness, as in (74a). Definiteness is thus marked both by the freestanding definite article and the definite suffix. Second, the presence of a restrictive relative clause can license the use of the freestanding definite article without the noun taking the definite suffix, as in (74b). Finally, the presence of a restrictive relative clause sometimes does not influence the way in which definiteness is marked, just like in non-restrictive relative clauses. In that case the noun modified by the restrictive relative clause only occurs with the definiteness suffix, as in (74c). In that case, the form is identical to non-restrictive relative clauses.^{52,53}

- (74) a. *den* *mus-en* *som vi såg*
 DEF.SG-NON-NEUTER mouse-DEF.SG-NON-NEUTER that we saw
 b. *den* *mus som vi såg*
 DEF.SG-NON-NEUTER mouse that we saw
 c. *mus-en* *som vi såg* (=73))
 mouse-DEF.SG-NON-NEUTER that we saw
 ‘The mouse that we saw’ (Hankamer & Mikkelsen 2005: 108)

The choice among the three different ways of marking in definiteness in (74) is subject to lot of variation among speakers. I refer the reader to chapter 3 of Julien (2005) for discussion of this variation.

The fact that non-restrictive relative clauses do not influence the definiteness marking is not surprising. Various scope facts (see Julien 2005:89-92 for an overview) indicate that non-restrictive relative clauses are interpreted outside the scope of a definite D. In that sense, they are similar to predicative adjectives (see section 2.1). Therefore, they will not trigger any double definiteness. Restrictive

⁵¹ Note that (73) is ambiguous between a non-restrictive and a restrictive reading, see (74c) below.

⁵² David Pesetsky (personal communication) suggests that the patterns in (74) might be related to the non-deictic use of demonstratives in comparable sentences in English, as in the examples in (i).

- (i) a. *Those students who passed the exam can proceed to the next course.*
 b. *The policie arrested all those people who failed to pay their taxes.*

⁵³ Hankamer & Mikkelsen (2005: 117) attribute two different structures to (74a) and (74b). They attribute to (74b) a raising-analysis in the sense of Bianchi (1999) and Kayne (1994). They analyze (74a) as involving a more traditional adjunction structure, in which the relative clause is adjoined somewhere in the nominal domain. Thanks to Anikó Lipták and Lisa Cheng for drawing my attention to this.

relative clauses on the other hand are more like attributive adjectives. They are interpreted in the scope of D. Therefore, the possibility of having double definiteness in a DP with a restrictive relative clause, as in (74a), is not surprising. If restrictive relative clauses are of the same semantic type as attributive adjectives and are merged at the same position, double definiteness in DPs with restrictive relative clauses can be explained in the same way as double definiteness in DPs with pronominal adjectives. However, from this perspective (74b) and (74c) remain a mystery. A lot is still unknown about the structure of the relative clauses in (74). It is therefore unclear whether the data can be incorporated in the present analysis or not. I will therefore leave a full account of the intriguing patterns of definiteness marking in DPs with restrictive relative clauses for further research.

4.4. Summary

In this section, I have examined how my analysis accounts for the distribution of double definiteness.

First, I had a look at two cases in which there is double definiteness in the absence of a pronominal adjective, namely definite DPs containing a weak quantifier or numeral and definite DPs in which the definite article was interpreted as a demonstrative. In both these cases, I argued that double definiteness is due to internal merge of D, just like in definite DPs with an adjective. In definite DPs with a weak quantifier or a numeral, this internal merge is triggered by a type mismatch. In the case of DPs with a demonstrative use of the definite article, internal merge of D is triggered in order to license a contrastive focus feature.

Second, I examined cases in which double definiteness is absent, despite of the fact that the DPs involved contain a pronominal adjective and are definite. These cases turned out not to be problematic for my analysis. The absence of double definiteness in DPs with *denna*-demonstratives and pronominal possessive pronouns turned out to confirm a core prediction of the grammar, namely that non-suffixal determiners do not double. In both cases, the determiner is a free morpheme. This renders the element inserted in the two copies of D completely visible for Chain Reduction, yielding the absence of a double spell out of D in these cases. Another case in which double definiteness was absent from definite DPs containing adjectives was definite DPs in which the pronominal adjective was part of a proper name. In that case, the adjective is not combined with the noun in syntax. This offers an explanation for the absence of double definiteness in this case. The final case was non-referential DPs. These turned out not to be definite. Given that the presence of a definite D is crucial to my analysis of double definiteness, non-referential DPs hence also do not challenge the analysis proposed here.

Finally, I discussed the interaction between relative clauses and definiteness marking. The analysis proposed here gives some nice insights in some of data concerning this subject. However, an account of all the data was left to further research.

After examining the detailed distribution of double definiteness in Swedish, and by extension also in Norwegian and Faroese, I will now turn to its cross-

The second pattern of definiteness marking is attested in Danish. Danish has both a freestanding definite article and a definite suffix, just like Swedish, Norwegian, and Faroese. As in these languages, the freestanding definite article occurs when DP contains an attributive adjective and the definite suffix occurs on unmodified nouns (77a,b). Unlike Swedish, the definite suffix and the freestanding definite article cannot co-occur in Danish. In DPs with a prenominal adjective, definiteness is only marked with the freestanding definite article, as in (77b). The definite suffix is obligatorily absent (77c). Put differently, Danish lacks double definiteness.

- (77) a. *hest-en* [Danish]
 horse-DEF
 ‘the horse’
 b. *den rød-e hest*
 the red-WEAK horse
 ‘the red horse’
 c. **den (rød-e) hest-en*
 the (red-WEAK) horse-DEF (Hankamer & Mikkelsen 2002)

The final pattern is found in modern Icelandic. Modern Icelandic always marks definiteness always by means of a definite suffix. This is illustrated in (78) for both an unmodified DP and one that contains an attributive adjective.

- (78) a. *hest-ur-inn* [Icelandic]
 horse-MASC.NOM.SG-DEF.MASC.NOM.SG
 ‘the horse’
 b. *góð-i mað-ur-inn*
 good-NOM.MASC.SG.WEAK man-NOM.MASC.SG-DEF.NOM.MASC.SG
 ‘the good man’ (Einarsson 1945)

In this section, I argue that most of this variation is predicted to occur under my analysis of double definiteness, given that there are two loci in my analysis at which crosslinguistic variation could potentially arise.

The first locus for crosslinguistic variation is the morphological properties of vocabulary item that is inserted in D. As shown above, it is essential for the licensing of double definiteness that the vocabulary item inserted in the two D-copies is a suffix. If it is a suffix, Local Dislocation causes morphological reanalysis of the vocabulary item inserted in the lower D-copy, suffixing it onto N. This morphological reanalysis renders the vocabulary item inserted in the lower D-copy invisible to Chain Reduction. This yields a double spell-out of the higher and lower copy of D. This, however, predicts that if the vocabulary item inserted in the D-copies is not a suffix, no double spell-out of the copies should occur. The reason for this is that in that case Local Dislocation is not triggered, leaving the lower D-copy fully visible to Chain Reduction. As a result Chain Reduction will delete the lower D-copy, preventing in this way a double spell-out. In section 4.2.1 above, I argued that this is the case for the *denna*-type demonstrative determiner and the prenominal possessive pronouns in Swedish, explaining the absence of double definiteness in

case these elements are inserted in D. This predicts that no doubling of the definite article should occur, in case a language has a definite article that is a free morpheme instead of a suffix. Below, I argue that this is the explanation of the absence of double definiteness in German and Dutch.

The second locus in my analysis for crosslinguistic variation is the ordering of Local Dislocation and Chain Reduction. In section 3.3.5 above, I argued that operations that take place between Linearization and Phonological Spell-Out are not inherently ordered with respect to each other. This offers the possibility that different orderings of operations yield different surface patterns in different languages, offering in this way an explanation for crosslinguistic variation. In Swedish and the other languages displaying double definiteness, Local Dislocation precedes Chain Reduction. As described above, this results in the double spell-out of the definite article. However, if Chain Reduction were to apply before Local Dislocation, the element inserted in the lower D-copy would be deleted before it has been morphological realized. I claim that this is what happens in Danish.

In this way, most of the variation within the Germanic languages can be accounted for by minor morphological differences between the languages, i.e. by the morphological properties of the vocabulary item inserted in D or a different ordering of operations on the morphological branch of the grammar. The Icelandic pattern of definiteness marking can however not be attributed to a morphological difference with the other Germanic languages. I will argue below that it is due to a minor difference in the syntactic component of the grammar.

I will now show in detail how the different patterns of definiteness marking can be explained under my analysis of double definiteness along the lines sketched above. I will start out this section by examining Dutch and German. I will then turn to Danish. Finally, I will add a note on Icelandic.

5.1. German and Dutch

As noted above, Dutch, and German definite DPs are always introduced by a freestanding definite article, whether an adjective is present or not. This was illustrated in (75) and (76) above, repeated here as (79).

- (79) a. **die** (*schön-en*) *Bücher* [German]
 DEF.PL (nice-WEAK) book.PL
 ‘the nice books’
- b. **de** (*mooi-e*) *boek-en* [Dutch]
 DEF.PL (nice-WEAK) book-PL
 ‘the nice books’

The inflection of attributive adjectives in Dutch and German is sensitive to properties of D. Like in Swedish, the inflection of attributive adjectives in Dutch is sensitive to the definiteness of D. Adjectives in definite DPs receive weak inflection that does not signal gender and number distinctions, like in (80a). Their counterparts in indefinite DPs receive strong inflection, which signals gender and number

distinctions (as in (80b)). In German, the adjectival inflection is sensitive to the inflection on D (cf. Roehrs 2006). If D is inflected, as in (81a), the adjective combines with the weak inflection. If D is uninflected, the adjective receives strong inflection, as in (81b).⁵⁵

- (80) a. *het* *mooi-e* *boek* [Dutch]
 DEF.NEUTER.SG nice-WEAK book
 ‘the nice book’
- b. *een* *mooi-∅* *boek*
 a nice.-STRONG.NEUTER book
 ‘a nice book’
- (81) a. *das* *schöne* *Buch* [German]
 DEF.NEUTER.SG.NOM nice-WEAK book
 ‘the nice book’
- b. *ein* *schön-es* *Buch*
 a nice-NEUTER.SG.NOM.STRONG book
 ‘a nice book’

This sensitivity of adjectival inflection to properties of D was my main motivation for adjoining attributive adjectives to DP in Swedish. In that way, D is in the search domain of the adjectival Probe explaining the sensitivity of the adjectival inflection to properties of D. Given the observation that German and Dutch do not differ from Swedish with respect to the sensitivity of the adjectival inflection to properties of D, the null hypothesis is that attributive adjectives in German and Dutch are also adjoined to DP.

Given that they are adjoined to DP, attributive adjectives in German and Dutch cause a type mismatch, just like their counterparts in Swedish. This type mismatch is then repaired through internal merge of D. Put differently, the syntactic derivation of German and Dutch definite DPs with prenominal adjectives is identical to that of their Swedish counterparts. This means that the differences in definiteness marking in these languages are not syntactic. The absence of double definiteness in German and Dutch should therefore have a morphological explanation. Definiteness markers in Dutch and German differ from those in the DD-languages in that they are

⁵⁵ In (81), the property of D being inflected or not corresponds to the definiteness of D. In (81a), D is both inflected and definite. In (81b), D is uninflected and indefinite. However, there are also cases in which an indefinite D is inflected, as for instance in the masculine singular dative (i). In that case, attributive adjectives receive weak adjectival inflection. Hence, the distribution of weak adjectival inflection in German is not governed by the definiteness of D, but by the presence or absence of inflection on D. This sets German apart from the other Germanic languages. In the other Germanic languages, including Dutch and Swedish, the definiteness of D is the factor that determines the distribution of weak adjectival inflection.

(i) *einem* *gross-en* *Mann*
 a.DAT.MASC big-WEAK man
 ‘a big man’

Strong and weak adjectival inflection in German will be discussed in detail in chapter 5.

never suffixes. As shown above for Swedish *denna*-type demonstratives and Swedish pronominal possessive pronouns, being a free morpheme bleeds a double spell-out of the element inserted in D. I therefore claim that the non-suffixal character of the Dutch and German definite article is the cause of the absence of double definiteness in Dutch and German.

Since they are free morphemes, definiteness markers in German and Dutch do not undergo Local Dislocation in the morphological component. This renders them fully visible for Chain Reduction. In the case of definite DPs containing adjectives, Chain Reduction will therefore always delete the lower copy of the definiteness marker. I illustrate this by spelling out the morphological part of the derivation of the Dutch DP *het mooie boek* ‘the nice book’ in (82).

As mentioned above, I assume that the syntactic structure of *het mooie boek* ‘the nice book’ is the same as the syntax of definite DPs containing adjectives in Swedish. Hence, the syntactic structure that enters the morphological component will be as in (82a). Next, Vocabulary Insertion and Linearization result in the string in (82b). As the definiteness marker *het* is not a suffix, there is no trigger for Local Dislocation. Hence it does not apply. When Chain Reduction applies next, both copies of the definiteness marker *het* are visible. Chain Reduction deletes the lower copy (82d). This results in the submission of the string in (82e) to the phonological component of the grammar.

- (82) a. SYNTACTIC OUTPUT
 [DP D_[def] [DP [AP A] D_[def] [NP N]]]
- b. VOCABULARY INSERTION AND LINEARIZATION
 *het * mooie * het * boek*
- c. LOCAL DISLOCATION
 N.A.
- d. CHAIN REDUCTION
 *het * mooie * ~~het~~ * boek*
- e. PHONOLOGICAL SPELL-OUT
 het mooie boek

The absence of double definiteness in German and Dutch is thus due to the morphological properties of the elements inserted in D. In German and Dutch, these elements are free morphemes instead of definite suffixes. In this way, the absence of double definiteness in Dutch and German receives the same explanation as the lack of double definiteness in Swedish with the *denna*-type demonstratives and the pronominal possessive pronouns (see section 4.2). I will now turn to Danish.

5.2. Danish

As shown above, Danish nouns take a definite suffix in unmodified definite DPs. This was illustrated in (77a) above, repeated here as (83a). In this respect, Danish resembles Swedish, in which the noun also takes a definite suffix in unmodified

definite DPs. However, Danish is different with respect to definite DPs with an adjective. In such cases, Danish DPs only mark definiteness with a freestanding definite article. The noun cannot take the definite suffix. This is illustrated in (83b) and (83c), a repetition of (77b) and (77c).

- (83) a. *hest-en* [Danish]
horse-DEF
'the horse'
- b. *den rød-e hest*
the red-WEAK horse
'the red horse'
- c. **den (rød-e) hest-en*
the (red-WEAK) horse-DEF (Hankamer & Mikkelsen 2002)

Danish thus lacks double definiteness. The inflection of attributive adjectives displays a strong-weak distinction in Danish. In the preceding section, I argued that the strong-weak indication in Dutch and German is an indication that the syntactic part of the derivation of definite DPs with prenominal adjectives is the same as in Swedish. Given the fact that there are no other indications to the contrary, this is also the null hypothesis for Danish. Hence, the result of the syntactic part of the derivation of (83b) involves a doubly layered DP-structure, as in (84).

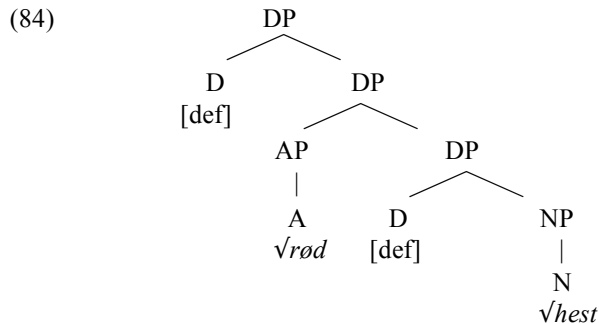

If definite DPs containing an adjective in Swedish and Danish have exactly the same syntactic structure, the absence of double definiteness in Danish should receive a morphological explanation. However, there seem to be no morphological differences between Danish and Swedish at a first glance. In the previous section, I attributed the absence of double definiteness in Dutch and German to the fact the definiteness markers in these languages are free morphemes. Such an analysis cannot apply to Danish. In Danish, the definiteness marker has suffixal properties, as can be seen in (83a) above. The absence of double definiteness in Danish should hence be explained differently. Thus, the absence of the double definiteness in Danish cannot be attributed to the syntactic component of the grammar, nor to properties of the definiteness marker. What is then the cause of the lack of double definiteness in Danish? I propose here that it is due to a difference that concerns the

second locus of variation pointed out above, the ordering of operations in the morphological component.

In section 3.3, I claimed that the derivation of definite DPs containing an adjective involves several morphological operations. The ones that are relevant for the present discussion are Chain Reduction and Local Dislocation. For Swedish, Chain Reduction is ordered after Local Dislocation (see the discussion of (39) and especially subsection 3.3.5). This ordering is a crucial part of my analysis of double definiteness. If the ordering were the other way around, double definiteness would never arise. In that case, Chain Reduction would delete the lower copy of the definiteness marker before it could undergo Local Dislocation. Under this scenario, the higher copy of the definiteness marker would then be the only one to be pronounced. This is contrary to the Swedish facts. Therefore, I adopted for Swedish the ordering in which Local Dislocation precedes Chain Reduction. However, as noted in 3.3.5, this is not an inherent ordering. Nothing excludes Chain Reduction from taking place before Local Dislocation, as long as both have applied before the derivation is handed over to the phonological component of the grammar. Swedish just made the parametric choice to apply Chain Reduction after Local Dislocation. I claim here that Danish follows a different parametric path with respect to this. Formulated differently, I argue that Chain Reduction applies before Local Dislocation in Danish. I will now first show that this ordering actually derives the Danish facts.

The outcome of the syntactic derivation of (83b) was the syntactic structure in (84). Vocabulary Insertion and Linearization applied to the syntactic structure in (84) result in the string in (85a). Note that the vocabulary item in both Ds is a suffix, just like in Swedish. Contrary to Swedish, the next step in the derivation is not Local Dislocation but Chain Reduction. Chain Reduction deletes the lower copy of the chain consisting of the two copies of the definiteness marker *-en* (85b). The next step in the derivation is Local Dislocation. However, Local Dislocation does not apply. The lower copy of *-en* already got deleted in the previous step of the derivation, while the higher copy is not adjacent to a suitable nominal host. Finally, D-insertion and phonological spell-out apply, (85d-e). This ordering of operations in the morphological component yields the correct result for Danish: a DP with a freestanding definite article, but without a definite suffix on the head noun.

- (85) a. *-en * røde * -en * hest* [Danish]
 b. CHAIN REDUCTION
*-en * røde * ~~-en~~ * hest*
 c. LOCAL DISLOCATION : n.a.
 d. D-INSERTION
*d-en * røde * hest*
 e. PHONOLOGICAL SPELL-OUT
den røde hest

Therefore, I propose here that the difference between Danish and Swedish is the ordering of Chain Reduction and Local Dislocation. In Swedish and other languages that display double definiteness, Local Dislocation applies before Chain Reduction.

This yields the result that both the higher and lower copy of the definiteness marker is spelled out. In Danish, on the other hand, Chain Reduction applies before Local Dislocation. This results in the spell-out of the higher copy of the definiteness marker, but not the lower one. This is schematized in (86).

- (86) Swedish (Norwegian, and Faroese):
 LOCAL DISLOCATION > CHAIN REDUCTION
Danish:
 CHAIN REDUCTION > LOCAL DISLOCATION

In this way, the difference between Danish and Swedish with respect to double definiteness is attributed to a different ordering of operations in the morphological component of the grammar. In a derivational model of the grammar, like the one adopted here, ordering operations is unavoidable.⁵⁶ In the best case scenario, most operations will be inherently ordered. However, it is unlikely that all operations are. In that case, languages can make different choices in the ordering of operations, yielding different surface patterns. Put differently, the ordering of operations in the morphological component of the grammar is the locus of some crosslinguistic variation.

5.3. Modern Icelandic

Above, I attributed the cross-linguistic variation in the Germanic languages with respect to definiteness marking to morphological factors. There is however one Germanic language for which morphological factors alone cannot explain how the way in which definiteness is marked differs from that in other Germanic languages: Icelandic. Instead, I argue that the different way of marking definiteness in Icelandic is due to an additional step in the syntactic derivation of definite DPs.

As mentioned above, Icelandic displays no double definiteness. In (modern) Icelandic, the sole marker of definiteness is a suffix on the head-noun of the DP.⁵⁷ The presence of an adjective has no effect on the way definiteness is expressed. This was illustrated in (78) above, repeated here as (87).

- (87) a. *hest-ur-inn* [Icelandic]
 horse-MASC.NOM.SG-DEF.MASC.NOM.SG
 ‘the horse’

⁵⁶ Note that ordering of operations is not necessary in the syntactic component of the grammar. The reason for this is simple: the syntactic component of the grammar consists of only one operation: Merge. Other syntactic notions like Agree are not operations but relations, which are established as a by-product of Merge.

⁵⁷ Vangsnes (1999: 133, fn 24) notices that in some formal registers, judged as archaic, a freestanding definite article is used instead of the definiteness suffix. This freestanding definite article displays the pattern described for German and Dutch above.

- b. *góð-i* *mað-ur-inn*
 good-NOM.MASC.SG.WEAK man-NOM.MASC.SG-DEF.NOM.MASC.SG
 ‘the good man’ (Einarsson 1945)

Above, I gave two different morphological accounts for the absence of double definiteness in other Germanic languages. None of these accounts gives an explanation for the absence of double definiteness in Icelandic. I attributed the lack of double definiteness in Dutch and German to the fact that the definiteness marker in these languages is a free morpheme. In Icelandic, the definiteness marker is however clearly a suffix, as can be seen in (87). For Danish, I argued that there is no double definiteness because the operations in the morphological component were ordered differently. Contrary to Swedish, I proposed that Chain Reduction applies before Local Dislocation in Danish. If that were also the case in Icelandic, one would expect the same alternation between a freestanding definite article and a definite suffix in Icelandic as in Danish. However, (87) shows that this is not the case. The absence of double definiteness in Icelandic hence is not explained by the morphological accounts of crosslinguistic variation I already offered.

For the other Germanic languages, I argued that the syntactic derivation of a DP with an attributive adjective was identical. However, there are reasons to believe that the syntactic derivation of these DPs involves an additional step in Icelandic. Support for this claim comes from the order between numerals and other elements in DP. In most Germanic languages, cardinal numerals always precede the head noun. This is illustrated in (88) for Norwegian.

- (88) *dei to (gul-e) skjort-e-ne* [Norwegian]
 the.PL two yellow-WEAK shirt-PL-DEF
 ‘the two (yellow) shirts’ (Julien 2005: 26)

However, Icelandic is an exception to this general Germanic pattern. As noted by Sigurðsson (1993, 2006) and Vangsnes (1999), cardinal numerals obligatorily follow the head noun in Icelandic definite DPs. This is illustrated in (89).

- (89) a. *bækur-nar þrjár* [Icelandic]
 books-DEF three
 b. **þrjár bækur-nar*
 three books-DEF
 ‘the three books’ (Vangsnes 1999: 145)

Moreover, if the noun taking the definite suffix is additionally modified by an adjective, the adjective precedes the noun, which in its turn precedes the numeral. This is shown in (90).

- (90) *frægu bækur-nar þrjár* [Icelandic]
 famous books-DEF three
 ‘the three famous books’ (Vangsnes 1999: 144)

The order in which the numeral follows the head noun is related to the presence of the definite suffix on the head noun. If the head noun does not take the definite suffix, as in indefinite or demonstrative DPs, the numeral precedes both the adjective and the noun. This is shown in (91) for demonstrative DPs and in (92) for indefinite DPs.

- (91) a. *flessar þrjár frægu bækur* DEM>NUM>A>N [Icelandic]
 these three famous books
 b. **flessar frægu bækur þrjár* A>N>DEM>NUM
 these famous books three
 c. **frægu bækur flessar þrjár* A>N>DEM>NUM
 famous books these three
 ‘these three famous books’ (Vangsnes 1999: 145)
- (92) a. *þrjár frægar bækur* NUM>A>N [Icelandic]
 three famous books
 b. **frægar bækur þrjár* A>N>NUM
 famous books three
 ‘three famous books’ (Vangsnes 1999: 145)



Sigurðsson (2006) and Vangsnes (1999) argue that the postnominal position of the numeral in the definite DP in (90) is the result of movement of a constituent containing the noun with the definite suffix and the adjective over the numeral, as in (93).

- (93) [A N+DEF] NUM [A N+DEF]

I adopt this idea and assume that this movement also takes place in the absence of a numeral. Moreover, I propose that this movement is only an additional step in a syntactic derivation that is for the rest identical to that of definite DPs in the other Germanic languages. Put differently, I claim that adjectives in Icelandic also trigger internal merge of D, but that after this step in the derivation the constituent containing the adjective, the lower D-copy and the noun is internally merged. This additional instance of internal merge derives the Icelandic pattern. In order to show this, I will discuss in more detail the derivation of the DP in (90).

The first relevant step in the derivation is the adjunction of AP to DP, just like in the other Germanic languages, see (94a). This causes a type mismatch that triggers internal merge of D, as in (94b). The next step in the derivation is however different from the other Germanic languages. The lower DP that contains both AP and N is internally merged as in (94c) (cf. the movement proposed by Vangsnes (1999) and Sigurðsson (2006) in (93) above).⁵⁸

⁵⁸ As pointed out to me by Lisa Cheng, it is important to determine the trigger for this instance of internal merge, especially since it seems to constitute an instance of subextraction. I leave this question to further research.

- (94) a. ADJUNCTION AP TO DP
 $[_{DP} AP [_{DP} D [_{NP} N]]]$
 b. INTERNAL MERGE D
 $[_{DP} D (NUM) [_{DP} AP [_{DP} D [_{NP} N]]]]$

 c. INTERNAL MERGE DP
 $[_{DP} [_{DP} AP [_{DP} D [_{NP} N]]] [_{DP} D (NUM) [_{DP} AP [_{DP} D [_{NP} N]]]]]$

Subsequently, the structure in (94c) is submitted to the CI-interface. The D-copy that is created as a result of internal merge in (94b) is interpreted at this interface, as well as the lower copies of A and N. All other instances of D, A and N are deleted at the CI-interface. This is shown in (95).

- (95) $[_{DP} [_{DP} \overline{AP} [_{DP} \overline{D} [_{NP} \overline{N}]]] [_{DP} D (NUM) [_{DP} AP [_{DP} \overline{D} [_{NP} N]]]]]$

The deletions in (95) ensure that AP is interpreted in the scope of D and that the type mismatch caused by the lower D is resolved.

The structure in (94c) is also submitted to the morphological component in which Vocabulary Insertion and Linearization apply. For the DP in (90), repeated here in (96), this results in the linear string in (97).

- (96) *frægu bækur-nar þrjár* [Icelandic]
 famous books-DEF three
 ‘the three famous books’ (Vangsnes 1999: 144)

- (97) VOCABULARY INSERTION & LINEARIZATION
*frægu * -nar * bækur * -nar * þrjár * frægu* -nar * bækur*

The next step is to satisfy the suffix property of the definiteness marker *-nar*. The second instance of *-nar* in (97) is suffixed on the noun through means of morphological rebracketing (see Embick & Noyer 2001), as in (98).

- (98) REBRACKETING
*frægu * -nar * bækur + nar* ____ * þrjár * frægu* -nar * bækur*

The suffix property of the two remaining instances of the definiteness marker *-nar* are then satisfied by means of Local Dislocation, as in (99).

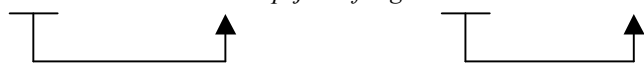
- (99) LOCAL DISLOCATION
*frægu * * bækur + nar + nar* þrjár * frægu* * bækur + nar*

Local dislocation however leads to two instances of *-nar* on the first copy of the noun *bækur* ‘books’. A haplology rule deletes one of these definite suffixes, as in (100).⁵⁹

- (100) HAPLOLOGY RULE
*frægu * bækur +nar+~~nar~~* þrjár * frægu* bækur + nar*

Next, Chain Reduction applies, deleting the lower sequence of the adjective and the noun with the definite suffix, as in (101).

- (101) CHAIN REDUCTION
*frægu * bækur +nar * þrjár *~~frægu* bækur + nar~~*

The derivation is then sent to the phonological component in order to be phonologically realized. This has the result in (102).

- (102) PHONOLOGICAL SPELL-OUT
frægu bækurnar þrjár

In this way, one additional instance of internal merge in narrow syntax results in a definiteness suffix on the noun in Icelandic definite DPs with an adjective, thus explaining the absence of double definiteness in Icelandic.

5.4. Summary and predictions

In the preceding sections, I examined the cross-linguistic variation with respect to definiteness marking in Germanic in light of my analysis of double definiteness. I attributed most of the variation to two points for which my analysis predicts potential crosslinguistic variation: the morphology properties of the vocabulary item inserted in D, i.e. whether it is a suffix or not, and the ordering of Chain Reduction and Local Dislocation. If D is a suffix and Local Dislocation precedes Chain Reduction, my analysis predicts the double definiteness pattern of definiteness marking. In case D is a suffix and Local Dislocation follows Chain Reduction, the Danish pattern of definiteness marking is expected. Finally, if D is free morpheme, the German and Dutch pattern of definiteness marking is expected. Note that in that case, the ordering of Chain Reduction and Local Dislocation becomes irrelevant, since Local Dislocation is not triggered if D is a free morpheme. This is summarized in the table in (103).

⁵⁹ Lisa Cheng notices that the definiteness suffix *-nar* is probably not a good host for a copy of itself.

- (103) CROSS-LINGUISTIC VARIATION IN DEFINITENESS MARKING BY THE DEFINITE ARTICLE DUE TO MORPHOLOGICAL VARIATION.

	+ suffix	-suffix
Local Dislocation before Chain Reduction	N-def, Def A N-def (Swedish, Norwegian, Faroese)	Def N, Def A N (German, Dutch)
Chain Reduction before Local Dislocation	N-def, Def A N (Danish)	

Furthermore, my analysis predicts that it is impossible to have a language with an identical DP-structure as Swedish, but that has the following pattern of definiteness marking: a freestanding definite article in the case of unmodified noun (Def N) and only a definite suffix (no freestanding definite article) in the case of a noun modified by an adjective (A N-def).⁶⁰ This pattern of definiteness marking would require deletion of the higher D-copy and Local Dislocation to be dependent on internal merge of D. All of which is impossible under the analysis presented here. As far as I know, such a language is unattested. Hence, this prediction of my analysis is borne out.

Note that my analysis also predicts restrictions on the variations there could exist among different determiners within the same languages. As argued for above, different determiners within a language can vary with respect to whether they are a suffix or not. In Swedish for instance, the definite article is a suffix, but the *denna*-type demonstrative is a free morpheme. Put differently, one expects the determiners that are free morphemes in Swedish to display the same pattern as the Dutch and German definite article. The same is expected for determiners being free morphemes in Danish. Crucially, it is not expected under the current analysis that within the same languages some determiners pattern as the Swedish definite article, while others display the same pattern as the Danish definite article. This is due to the fact that the ordering of Chain Reduction and Local Dislocation is a general property of the grammar of a particular language, not a property of particular vocabulary items. Again, this prediction of the analysis seems to be borne out. There are no determiners in Swedish that display the same pattern as the Danish definite article, nor are there any Danish determiners that display the same pattern as the Swedish definite article.

Only the Icelandic pattern of definiteness marking could not be explained by the morphological factors in (103). I therefore argued that the absence of double definiteness in Icelandic is due an additional instance of internal merge in the syntactic component.

This completes my analysis of double definiteness in particular and the way in which definiteness marking varies across Germanic in general. In the next

⁶⁰ Thanks to David Pesetsky for drawing my attention to the predictions of the analysis which types of languages should be unattested.

section, I examine previously proposed analyses of double definiteness. I show that each of these analyses suffers from one or more serious problems.

6. Previous analyses of double definiteness

In the preceding sections, I introduced my analysis of double definiteness and showed how it deals with the distribution of double definiteness in Swedish as well as with the cross-linguistic variation in definiteness marking in Germanic. In this section, I discuss previous analyses of double definiteness. Each of these analyses will turn out to have one or more serious problems. I will show that my analysis does not suffer from these problems. In this way, the discussion in this section will offer additional support for my analysis.

6.1. Head movement accounts (Delsing 1993, Embick & Noyer 1997)

Delsing (1993), Embick & Noyer (2001), propose that double definiteness in DPs containing an adjective, as in (104b), is caused by an intervention effect on head movement. This intervention effect is created by the adjective.

- (104) a. *hus-et* [Swedish]
house-DEF.NEUTER.SG
'the house'
- b. *det gul-a hus-et*
the.NEUTER yellow-WEAK house-DEF.NEUTER.SG
'the yellow house'

They analyze unmodified definite DPs, like (104a), as involving head movement of N to D (105).⁶¹ This movement takes place in order to license the definite D. Moving N to D allows D to be spelled out as the definiteness suffix on N.

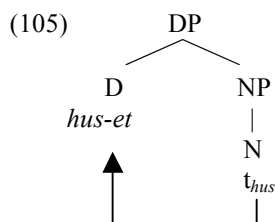

⁶¹ N-to-D raising in unmodified definite DPs in the Double definiteness languages has also been proposed in Delsing (1988), Taraldsen (1990, 1991), Santelmann (1993), and Kester (1993). However, these studies either do not address double definiteness or they give an explanation for double definiteness in which the adjective does not block movement of N.

In the case of definite DPs containing an adjective like (104b), the adjectival head intervenes between N and D. Hence, this adjectival head blocks head-movement of N to D, because of the head-movement constraint (106).⁶²

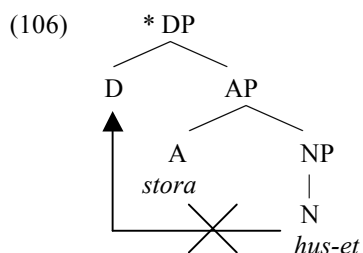

Because movement of N to D is prohibited, the definite D cannot be spelled out as a suffix on the head noun. In order to spell-out the features of the definite D in another way, the freestanding definite article is inserted in D (107).

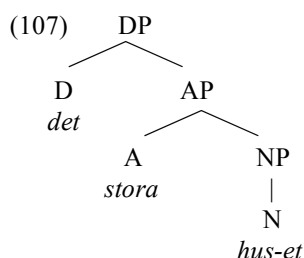

In the analyses of Delsing (1993) and Embick & Noyer (2001), the intervention created by the adjective for N-to-D movement offers in this way an explanation for the presence of the freestanding definite article. However, the presence of the definite suffix in definite DPs with a pronominal adjective has to be explained differently.

Embick & Noyer (2001) attribute the presence of the definite suffix to a kind of concord: if D is definite, then N should be marked for definiteness as well. In addition to this, they assume that a definite D needs to be spelled out. In definite DPs without a modifier, the N has moved to D, as above in (105). This allows for spelling out the definite D and for marking N as definite with the help of a single morpheme: the definite suffix. When the adjective blocks head movement of N to D, as in (106), the definite D cannot be spelled out as a definite suffix on N. The free definite article spells out D instead, as in (107). However, the insertion of the free

⁶² The structure in (106) is the one used in Embick & Noyer (2001). Delsing (1991) uses a slightly different structure. The only difference between the two structures is that NP is not a complement of A in Delsing (1993), but a right branching specifier of AP. This difference has no consequences for the discussion here.

definite article is not sufficient to mark N as definite. For that purpose, the definite suffix is inserted.

According to Delsing (1993), the definite suffix is the real marker of definiteness in Swedish DPs. The suffix is base-generated on N. He argues that the D-position also needs to be lexicalized. In definite DPs without an adjective, the definite suffix on N is able to perform the task of lexicalizing D by N-to-D movement. However, when DP contains an adjective, N-to-D movement is blocked and D cannot be lexicalized by the definite suffix. In order to lexicalize D, the freestanding definite article is inserted. For Delsing, this freestanding definite article is an expletive article, while the definiteness suffix is the real marker of definiteness. This is different from Embick & Noyer's analysis. In that analysis, the real expression of definiteness is the freestanding definite article, while the definite suffix is the result of some kind of definiteness concord.

The analysis proposed in Santelmann (1993) resembles the approaches discussed above. She also derives double definiteness through a blocking effect of the adjective on N-to-D movement. However, the reason behind this blocking effect is different in Santelmann's analysis. She does not adhere to the view that adjectives are heads. Therefore, adjectives cannot block head movement in her analysis. Instead, she assumes that adjectives are N'-adjuncts and proposes that movement of N to D is blocked, because such a movement will block the licensing of the adjectival inflection. However, she is not explicit as to why this is the case. I will therefore not discuss this analysis any further.

6.2. Problems for the head movement accounts

The most important problem for any account that assumes that the adjective blocks N-to-D movement in Swedish, is the existence of languages that arguable have N-to-D movement, but in which an adjective does not block this movement. Italian is one of these languages, as argued by Longobardi (1994, 2001, 2005, 2006). He argues that Italian proper names optionally undergo N-to-D movement. Proper names in Italian either occur without, as in (108a), or with a definite article, as in (108b). In the latter case, the proper name, *Roma*, follows the adjective *antica* 'ancient'. In the former case, the proper name precedes *antica*.

- (108) a. *Roma antica* _{t_{Roma}} *era una città potente* [Italian]
 Rome ancient was a city powerful
 b. *L' antica Roma era una città potente*
 the ancient Rome was a city powerful
 c. **Antica Roma era una città potente*
 ancient Rome was a city powerful
 'ancient Rome was a powerful city' Longobardi (2006:3)

Longobardi analyzes these data in terms of N-to-D movement. In (108b), N has not moved to D. Therefore, it follows the adjective *antica*. In this case, D needs to be spelled out by the definite article. The definite article cannot be omitted, as

illustrated in (108c). In (108a), N has moved to D over the adjective. In that case, N supports D. The insertion of a definite article is hence not needed.⁶³

If adjectives block N-to-D movement in Swedish, the question is why they do not block it in Italian (cf. Bernstein 2001). An explanation for this would be to claim that Italian adjectives are not heads within the nominal extended projection, but specifiers or adjuncts, while they are heads in Swedish.⁶⁴ This will block head movement of N-to-D in Swedish, but not in Italian. However, there is no independent evidence that can corroborate this structural difference. Therefore, I conclude that the adjective does not block head movement in Swedish.

Another problem for Delsing's (1993) and Embick & Noyer's (2001) analyses is that they do not explain why the adjective cannot move to D to lexicalize this head (cf. Hankamer & Mikkelsen 2002, 2005).⁶⁵ As Julien (2002, 2003, 2005) points out, it is also unclear why the noun cannot first move to A, resulting in a complex A+N head, and subsequently move to D in order to support it. I refer the reader to Hankamer & Mikkelsen (2002, 2005) and Julien (2003, 2005) for a detailed discussion of these points.

Finally, Embick & Noyer propose that the definiteness suffix on N in Swedish definite DPs is licensed through a 'type of concord'. However, they do not situate this in a more general theory about agreement/concord. They simply stipulate the following feature assignment rule at PF: 'Assign [def] to the head N in a DP with the [def] property' (2001: 583, (65)). Hence, their account of the definite suffix is entirely internal to their analysis. Note that the concord-rule advanced by Embick & Noyer differs radically from the standard view on agreement. In the standard view, agreement markers (Probes) are only licensed when they c-command an element (a Goal) that possesses the features the agreement marker expresses. In Embick & Noyer's concord rule, it is the other way around: D, the element that possesses the definiteness feature, c-commands the definite suffix, which is the agreement marker. Embick & Noyer (2001) are not the only ones to propose that

⁶³ Longobardi's analysis of the facts in (108) predicts that the word order 'definite article>proper name>adjective' is ungrammatical, because N-to-D bleeds the spell-out of D as the definite article. However, this word order is actually attested (Longobardi 2005).

(i) *La Roma ANTICA fu la città più importantedel Mediterraneo*
 the Rome ancient was the city most important of.the Mediterranean
 'Ancient Rome was the most important city of the Mediterranean.'

(Longobardi 2005: 10)

However, Longobardi analyses the word order in (i) not through N-to-D movement, but in terms of a different position of the adjective in (i) as compared to (108). In (i), the adjective is merged in a position following N. This view is supported by the reading of the adjective in (i). In (i), the adjective necessarily gets a contrastive reading. This reading is not required for the adjective in (108).

⁶⁴ Another possible explanation (David Pesetsky personal communication) would be to propose that adjectives in Italian and Swedish are both specifiers (or adjuncts) but that the properties of another head is responsible for blocking head movement in Swedish, but that the properties of this head in Italian are such that head movement is not blocked. However, there is no independent evidence that supports an analysis among these lines.

⁶⁵ A way out of this problem might be to propose that the feature content of D is incompatible with that of D. However, such an explanation is not given by Delsing (1993) and Embick & Noyer (2001).

the definite suffix is some kind of agreement marker without further justification. Bernstein (1997) and Giusti (1994) also propose such an analysis.

The analysis of double definiteness proposed in section 3.3 does not suffer from these problems. First, it does not involve any head movement of N to D. As a result, all the problems above related to this do not apply to my analysis. Second, the definite suffix is just a spell-out of a D-head in my analysis; it is not a concord marker. This avoids the problem of analyzing the definite suffix as a concord marker.

6.3. The phrasal movement approach (Julien 2002, 2003, 2005)

Similar to the head movement approaches above, Julien (2002, 2003, 2005) proposes that double definiteness is the result of an intervention effect created by a prenominal adjective. However, in Julien's analysis, the adjective is not an intervener for head movement. Instead, it is an intervener for phrasal movement to Spec DP of a constituent containing the head noun.

Julien adopts the structure of DP in (109). In this structure, Num is the head that hosts the number morphology, while n is the head that hosts the definite suffix.⁶⁶ α P is the functional projection that hosts attributive adjectives in its specifier. Weak quantifiers and numerals, on the other hand, occur in the specifier of CardP. CardP and α P are only present in DP if the DP contains adjectives and weak quantifiers. N undergoes head movement to Num and n in order to pick up the number and definiteness suffixes of the noun.

$$(109) \left[{}_{DP} D \left[{}_{cardP} \text{numerals} \left[\text{card} \left[{}_{\alpha P} AP \left[\alpha \left[{}_{nP} N+Num+n \left[{}_{NumP} t_{N+Num} \left[{}_{NP} t_N \right] \right] \right] \right] \right] \right] \right] \right]$$

According to Julien, D needs to be licensed in two ways. First, it is a Probe for phi- and definiteness features. Second, D needs to be identified through the presence of overt material either in D or in spec DP if the reference of DP depends on D (cf. Longobardi 2001). The element inserted in Spec DP or D needs to carry a nominal category feature.

In unmodified definite DPs, like *huset* 'the house', D will enter into Agree with n in order to value its unvalued features. Subsequently, D needs to be identified. As D is already in an Agree-relation with n and Agree is a prerequisite for move (cf. Chomsky 2001), nP is moved to Spec DP for the identification of D. This is shown in (110).

⁶⁶ The head that hosts the definite suffix is called 'art' instead of 'n' in Julien (2002).

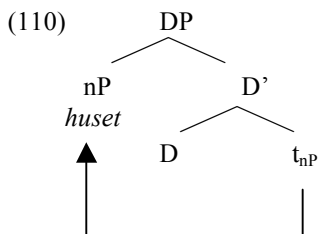

If DP contains a prenominal adjective, as in (104b) *det stora huset* ‘the big house’, DP contains αP with AP in its specifier. Via α , AP agrees with nP. As a result, the closest Goal for D is now AP. Thus, D will enter into Agree with AP. The next step is the identification of D. In this case, Moving AP to spec DP will not identify D, because AP is not endowed with a nominal category feature. Moving nP to Spec DP is not an option either. D is not in an Agree-relation with n. Agree being a prerequisite for Move, movement of nP to Spec DP is blocked. This is illustrated in (111).

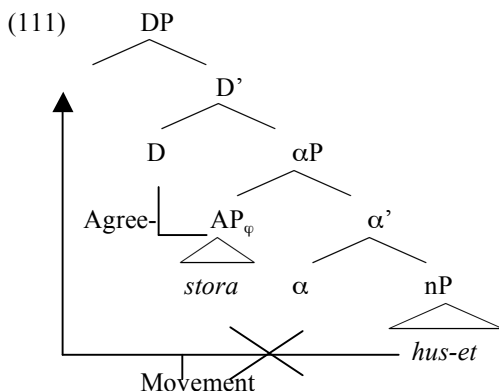

Because D cannot be identified through movement, the freestanding definite article is inserted in D as a last resort mechanism to identify D, as in (112).

(112) $[_{DP} det [_{\alpha P} stora [\alpha [_{nP} huset\dots]]]]$

In this way, double definiteness is the result of an intervention effect of the adjective for phrasal movement to spec DP.

6.4. Problems for the phrasal movement approach

In Julien’s analysis, it is essential that adjectives in definite DPs agree in phi-features and definiteness. If adjectives were not to agree themselves, they wouldn’t have phi-features and definiteness features. They would then not be a suitable Goal

for the probing of the definite D. In that case, D would agree with the next possible Goal. In this case, the next Goal is n.⁶⁷ Therefore, Agree (D,n) would be established. This should license nP-movement to Spec DP, exactly as in unmodified definite DPs. As a consequence, nP-movement would not be blocked by AP, because AP does not agree with D. Hence, one would then not expect any difference between definite DPs with an adjective and those without one. As a consequence, double definiteness would not be accounted for.

Although it is essential for Julien's analysis that adjectives agree in definite DPs, adjectives in definite DPs do not display a morphological reflex of this agreement. The adjectival inflection in definite DPs in Swedish and Norwegian is invariant. It does not express any agreement in definiteness, number, and gender features. This is shown for Swedish in the table in (113).

(113) SWEDISH ADJECTIVAL INFLECTION ADJECTIVES IN DEFINITE AND INDEFINITE DPs

Phi-features	SG, NON-NEUTER	SG, NEUTER	PL
Inflection A in indef. DPs	-∅	-t	-a/-e
Inflection A in def. DPs	-a/-e	-a/-e	-a/-e

As can be seen in (113), the adjectival inflection in definite DPs is the invariant *-a* or *-e*. These suffixes do not express any gender and number distinctions. In addition, they also do not express definiteness, because they also occur in indefinite DPs in the plural. Hence, there is no morphological evidence that adjectives in definite DP actually agree in Swedish and Norwegian. Julien (2005:47) therefore proposes that although the adjective is fully specified for gender, number, and definiteness features by Agree in syntax, these features are deleted in the morphological component by an impoverishment rule (cf. Halle 1997, Sauerland 1996). Because this rule applies before Vocabulary Insertion, the adjectival agreement is not reflected on the inflection. The relevant features are simply deleted before the inflection marker is inserted. The problem with this solution is that there is no independent evidence for this impoverishment rule. It is just a descriptive rule.

In chapter 4, I will show that my analysis of double definiteness renders it possible to explain adjectival agreement in Swedish and Norwegian without resorting to a stipulative impoverishment rule. I will now examine the lexical analysis of double definiteness put forward in Hankamer & Mikkelsen (2002, 2005).

⁶⁷ One could object that the next possible goal is α instead of n. However, the problem with α is that it never receives morphological realization, as far I can see. There is therefore not independent evidence that it actually agrees. Hence, I conclude that α is also not a suitable Goal for D.

6.5. The lexicalist approach: Hankamer & Mikkelsen (2002, 2005)

Hankamer & Mikkelsen (2002, 2005) propose an analysis of double definiteness that relies on the notion of blocking. According to them, the suffixation of the definite suffix in Swedish is the result of the application of a lexical rule. This rule applies prior to syntax. This rule does not only append the definiteness suffix to the noun, but also changes the category of the noun from N to D. They call this rule ‘Rule D’. Rule D is given in (114)

$$(114) \quad \begin{array}{ccc} /x/ & \rightarrow & /x/-DEFINITE SUFFIX \\ N & & D \\ & & [DEF] \end{array}$$

The application of this rule turns a noun into a definite determiner. In the case of the noun *hus* ‘house’, Rule D converts *hus* into a definite D by attaching the definite suffix *-et* to *hus*. This yields a D that contains *huset* ‘the house’. This result is inserted in syntax and projects the DP structure in (115). Note that the DP in (115) does not contain a NP. NP is not projected in this case, because N was converted into D by rule D.

$$(115) \quad \begin{array}{c} DP \\ | \\ D \\ hus-et \end{array}$$

According to Hankamer & Mikkelsen, rule D blocks the generation of the syntactic structure in (116b). In (116b), the noun is inserted as a regular N. After insertion, it combines with D resulting in a definite DP. Hankamer & Mikkelsen follow Poser (1992) by assuming that a lexical rule blocks a syntactic derivation if both have the same result. Formulated differently, they assume that ‘lexical expressions [...] block equivalent phrasal expressions’ (Hankamer & Mikkelsen 2002: 137). This blocking mechanism is also known as Poser-blocking. The syntactic derivation in (116b) and the lexical rule D yield the same result: a definite DP. The existence of rule D hence blocks the syntactic derivation in (116b).

$$(116) \quad \begin{array}{l} \text{a.} \quad * \textit{det} \qquad \qquad \textit{hus} \\ \qquad \qquad \text{DEF.NEUTER.SG} \quad \text{house} \\ \text{b.} \quad * \quad \text{DP} \\ \qquad \quad \swarrow \quad \searrow \\ \text{D} \qquad \qquad \text{NP} \\ \textit{Det} \qquad \quad | \\ \qquad \qquad \text{N} \\ \qquad \qquad \textit{hus} \end{array}$$

In this way, Poser-blocking ensures that unmodified definite DPs take a definite suffix instead of a freestanding definite article. Things are however different if the noun is modified by a prenominal adjective, as in (117).

- (117) *det stor-a hus-et* [Swedish]
 the.NEUTER big-WEAK house-DEF.NEUTER.SG
 ‘the big house’

Hankamer & Mikkelsen assume that prenominal adjectives are necessarily adjuncts to NP. If rule D applies, there is however no NP for the adjectives to be adjoined to, only a DP. Hence, the application of rule D would make the derivation crash (118).

- (118) *
-
- ```

 graph TD
 DP1[DP] --- AP[AP]
 DP1 --- DP2[DP]
 AP --- stora[stora]
 DP2 --- D[D]
 D --- hus-et[hus-et]

```

However, combining N(P) and D in the syntax in order to create a definite DP makes it possible for the adjective to adjoin to NP. In that case, D is realized as the freestanding definite article and N as the head noun. This is illustrated in (119).

- (119)
- 
- ```

  graph TD
    DP1[DP] --- D1[D]
    DP1 --- NP1[NP]
    D1 --- det[det]
    NP1 --- AP[AP]
    NP1 --- NP2[NP]
    AP --- stora[stora]
    NP2 --- N[N]
    N --- hus-et[hus-et]
  
```

In this case, the syntactic derivation in (119) takes precedence over the application of rule D, because rule D does not lead to a convergent derivation. A lexical derivation can only block a syntactic derivation in the case the lexical derivation converges.

The presence of the definite suffix on the noun in (119) is not straightforwardly explained in this analysis. In order to account for this, Hankamer & Mikkelsen (2002) propose that the category change of rule D is optional in Swedish. Hence, rule D can optionally create a N with the definite suffix without changing the N to D. Furthermore, Hankamer & Mikkelsen assume that a definite D with the freestanding definite article selects for a NP headed by a N with the definite suffix. Hence, rule D must apply in (119) without changing the category of N in order to meet the selectional requirements of D.

To summarize, the presence of the freestanding definite article in Swedish definite DPs with a prenominal adjective is licensed because rule D does not lead to

a convergent derivation. The definite suffix, in this case, is the result of selection by D for a N which takes the definite suffix.

6.6. Problems for the lexical approach

Hankamer & Mikkelsen's approach to double definiteness is not without problems. The most important problems have to do with the presence of the definite suffix in modified definite DPs in Swedish.

First, they simply state that the freestanding definite article in (119) selects for a noun with a definite suffix. This is just a restatement of the fact that both the freestanding definite article and the definite suffix occur in (119). Hence, the presence of the definite suffix on the noun in modified definite DP does not receive a principled account. Formulated differently, Hankamer & Mikkelsen do not offer an insightful explanation of why definite DPs with a prenominal adjective have a double marking of definiteness in Swedish.

Second, suffixation of the definite suffix can optionally change the category label of the noun in Hankamer & Mikkelsen's analysis. In unmodified definite DPs without an adjective, the suffixation changes the category label of the noun from N to D. In definite DPs with a prenominal adjective, the suffixation does not change the category of the noun. So, there seem to be two suffixation rules in Hankamer & Mikkelsen's analysis. Both rules append the definite suffix to the noun, but only one changes the category of N to D, the other does not. Given Occam's razor, an analysis in which the definite suffix is attached to the noun by a single rule is to be preferred over an analysis in which there are two rules that do this job. In my analysis, the suffixation is the result of a single operation in both modified and unmodified definite DPs: Local Dislocation. It is therefore to be preferred over Hankamer & Mikkelsen's account.⁶⁸

6.7. The phase-based account (Heck, Müller & Trommer 2007)

Heck, Müller & Trommer (2007) propose that double definiteness arises in order to bring the definiteness feature to the edge of a phase. Following Heck & Zimmermann (2004), they assume that DP is a phase. In addition, they propose that the definiteness feature must be available for operations outside the DP-phase (cf. definiteness agreement in Hungarian). According to Heck, Müller & Trommer (2007), only the leftmost overt material in a phase is available for computations outside that phase. This is formalized in their definitions of the Phase Impenetrability Condition and the Edge Domain, given in (120).

⁶⁸ In addition to their lexical account of double definiteness, Hankamer & Mikkelsen (2005) give an alternative account in the framework of Distributed Morphology. However, this analysis has some serious drawbacks as compared to my analysis. I refer the reader to footnote 19 for a discussion of these disadvantages.

- (123) PHASE BALANCE
 For every Probe in the numeration, a matching Goal must be
 accessible in the current phase. (Heck et al. 2007: 3)

Given the assumption that a Probe for [def] is still in the numeration when the DP-phase is completed, the constraint in (123) forces [def] to move to the edge domain of the DP-phase.

6.8. Problems for the phase-based account

Heck, Müller & Trommer's account has some problematic aspects. First of all, they do not offer an explanation as to why the definiteness suffix occurs on N in modified definite DPs in Swedish. They signal this themselves: 'for Swedish we need the additional stipulation that the lower copy of [def] is spelled out, too' (Heck, Müller & Trommer 2007: 4). In this respect, their account suffers from the same problem as that of Hankamer & Mikkelsen (2002, 2005). In my analysis, the spell out of the definite suffix in modified definite DP is explained through the interaction between Local Dislocation and Chain Reduction.

Second, the movement of the definiteness feature to D is triggered by a Probe that is not yet present in the syntactic derivation. As explained above, Heck, Müller & Trommer assume that unsatisfied Probes in the numeration trigger movement to the phase edge (cf. the Phase Balance constraint in (123)). However, it seems unlikely that elements that did not enter the syntactic derivation yet, trigger syntactic operations. That would be an instance of unwanted look ahead. In my analysis, a definite D is moved in order to repair a type mismatch. However, this type mismatch is detected in syntax prior to the movement of D. Hence, the look ahead problem does not exist for my analysis.

Third, it is not exactly clear why the [def]-feature should be available for syntactic operations outside the DP-phase in Swedish. Unlike Hungarian, Swedish does not have any morphological agreement for definiteness.

6.9. Summary

Above, I discussed several previous analyses of double definiteness. I pointed out some of the major problems of these analyses. Remarkably, there is one fact that most of these analyses fail to explain, the presence of the definite suffix on the noun in Swedish definite DPs with a prenominal adjective. In my analysis, this is elegantly accounted for by bleeding of Chain Reduction by Local Dislocation. In addition, I showed that my analysis also does not suffer of most of the other problems of previous analyses. This constitutes additional support for the analysis defended here.

7. Conclusion

In this chapter, I gave an account of double definiteness in Swedish, Norwegian, and Faroese. I argued that the syntactic component creates a DP structure with two D-copies. The presence of these two D-copies is triggered by a type mismatch created by the adjunction of AP to DP. In this structure, both the inflection and the interpretation of the adjective can be correctly licensed. In the morphological component, the suffixation of the lower D ensures that both Ds are spelled out. The analysis cannot only handle the fine grained distribution of double definiteness in Swedish, Norwegian, and Faroese, but also accounts for a great deal of the crosslinguistic variation concerning definiteness marking in Germanic. To be more precise, I claimed that in all Germanic languages definite DPs with prenominal adjectives have a structure with two D-copies. I attributed most of the variation among the Germanic languages in the way in which definiteness marked to morphological factors.

The present analysis provides a detailed account of both the syntactic and the morphological derivation of definite DPs with prenominal adjectives. I hope to have shown that the integration of detailed morphological and syntactic analyses lead to deeper insights in the shape of definite DPs than separate morphological or syntactic accounts. In that way, this chapter constitutes an argument in favor of exploring the interaction between syntax and morphology.

The syntactic derivation of definite DPs containing adjectives proposed in this chapter forms the basis for my analysis of agreement on attributive adjectives in the following chapters. Before introducing this analysis, I will however first investigate in the next chapter the syntactic configuration in which agreement can be established.

Chapter 3

The structural condition on Agree

1. Introduction

Agreement is not licensed in just any given syntactic configuration. The element that displays agreement must be in a certain position with respect to the element that determines the agreement. This is illustrated in (1). The ungrammaticality of (1a) shows that the copula in the embedded clause cannot agree with the singular subject of the matrix clause *my friend*. Instead, the copula must agree with the embedded subject, the plural DP *his brothers*, as in (1b).

- (1) a. **My friend says that his brothers is laughing.*
b. *My friend says that his brothers are laughing.*

This shows that the embedded subject in (1) is in the appropriate syntactic configuration with respect to the T in the embedded clause in order to determine the agreement on the copula, while the matrix subject is not. The observation that agreement is only licensed in certain configurations raises the question of how these configurations are best defined.

Chomsky (2000, 2001) argues that the configurations in which agreement takes place must be defined in terms of c-command. For Chomsky, agreement is the result of the syntactic relation Agree between two syntactic nodes, the Probe and the Goal. The Probe is the syntactic node associated with the element that displays agreement, while the Goal is the syntactic node associated with the element that determines the agreement. The Probe must c-command the Goal in order to establish Agree. This requirement is given in (2).^{1,2}

¹ The c-command requirement is not the only condition on Agree. In addition, Chomsky (2000: 122, 2001: 4) also proposes:

- (i) Matching: The features on the Goal should match the uninterpretable unvalued features on the Probe.
- (ii) Activeness: Both the Probe and the Goal should be active, i.e. have uninterpretable features.
- (iii) Locality: No other potential Goal can intervene between the Probe and the Goal.

In this chapter, I will exclusively be concerned with the structural condition on Agree. I will discuss and modify some of the other conditions in chapter 4.

² Baker (2008) proposes an alternative c-command requirement that is different from the standard definition in (2) in that it is less restrictive. Under Baker's version of the c-command requirement, the Probe must c-command the Goal or the Goal must c-command the Probe. Given that it is far less

- (2) C-COMMAND REQUIREMENT ON AGREE Chomsky (2000:122)
The Probe must c-command the Goal

Under Chomsky's c-command requirement, the facts in (1) receive the following explanation. In (1), the T-node of the embedded clause is the Probe, which is associated with the copula, the element that displays agreement. The impossibility of the agreement between the copula and the matrix subject *my friend*, (1a), is attributed under the c-command requirement to the fact that the embedded T does not c-command any copy of *my friend*. Under standard assumptions, *My friend* enters the derivation in the matrix spec vP and is then moved to the matrix spec TP. None of these positions is c-commanded by the T of the embedded clause. Hence, Agree is impossible according to the c-command requirement, as in (3a). However, the embedded T does c-command the copy of *his brothers* in the embedded spec vP. Hence, the c-command requirement on Agree is met and the embedded T can agree with *his brothers*, as in (3b).

- (3) a. NO C-COMMAND, NO AGREE POSSIBLE

$$[_{TP} \text{My friend } [_{vP} \text{my friend says } [_{\text{that}} [_{TP} \text{his brothers } T_{COP} \text{laughing}]]]].$$

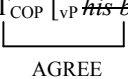
- b. C-COMMAND, AGREE POSSIBLE

$$\text{My friend says that } [_{TP} \text{his brothers } T_{COP} [_{vP} \text{his brothers laughing}]].$$

In recent minimalist work, Chomsky's (2000, 2001) c-command requirement has become the standard view on the syntactic configuration in which agreement is licensed. However, c-command is not a primitive syntactic relation, i.e. it is itself defined in terms of dominance, another syntactic relation, (4).³

- (4) C-COMMAND (Chomsky 1995: 35)
 α c-commands β if α does not dominate β and every γ that dominates α dominates β (i.e. α c-commands its sister and everything that is contained in its sister.)

This renders the c-command condition suspicious. Is it really necessary to formulate the structural condition on Agree, a core relation of Narrow Syntax, in terms of the complex notion of c-command? Can it not be defined by using a more primitive syntactic relation? In this chapter, I will address these questions and examine whether Chomsky's choice of defining the structural condition on Agree in terms of

restrictive than the standard definition or any of the other alternative formulations for the structural condition on Agree examined in this chapter, Baker's version of the c-command requirement is certainly not the null hypothesis for the structural condition on Agree. I will therefore not examine it in this chapter.

³ As pointed out to me by David Pesetsky (personal communication), there are, however, also non-standard views which take c-command a primitive of syntactic theory and dominance a derived notion, see Frank & Vijay-Shanker (2001), Frank, Hagstrom & Vijay-Shanker (2002).

c-command is justified. In order to determine this, I will propose an alternative structural condition on Agree that uses the more primitive syntactic relation of dominance and compare this with the c-command requirement.

I will first introduce this alternative condition, the dominance requirement. I will then compare it with Chomsky's c-command requirement by examining the empirical predictions both requirements make. The data discussed in this chapter will turn out to be inconclusive. On the one hand, there are indications that both the dominance requirement and the c-command requirement are adequate definitions of the structural condition on Agree. On the other hand, each requirement faces empirical problems. At the end of this chapter, I will however adopt the dominance requirement, because it is formulated using a more primitive syntactic relation. In the next chapter, chapter 4, I will first review some other aspects of the theory of Agree and then present an analysis of agreement on attributive adjectives in Germanic that uses the dominance requirement. In chapter 6, I will then show that the empirical problems for the dominance requirement introduced in this chapter turn out to be only apparent given the analysis in chapter 4.

2. C-command vs. Dominance

In the introduction, I raised the question of whether the configurations in which agreement is licensed could not be defined by using a more primitive relation than c-command. In this section, I will introduce an alternative to Chomsky's (2000, 2001) c-command requirement on Agree. This alternative will be defined in terms of the basic syntactic relation of dominance. I will therefore refer to this alternative as the dominance requirement on Agree. I will show that the dominance requirement makes specific predictions about the configurations in which agreement is possible. In order to compare the dominance requirement with the c-command requirement, I will also examine the specifics of the c-command requirement in more detail. However, by doing so, it will turn out that Chomsky (2000) presents the c-command requirement in two different ways. The first one is that a Probe must c-command a Goal, as in (2) above. The second one is that the Goal must be in the complement of the Probe. Chomsky presents these two formulations as mere notational variants of one and the same requirement. However, I will argue on the basis of work by Rezac (2003, 2004) that they actually represent two different requirements. Each of these makes its own predictions. For this reason, I will consider them to be two different candidates for the structural condition on Agree. I will examine in detail how these two requirements are different from each other and from the dominance requirement. I will in particular be concerned with their predictions and their theoretical complexity. The discussion in this section will lay the theoretical groundwork for the empirical discussion in the following sections. In those sections, I will try to determine which of these requirements constitutes the empirically most adequate formulation of the structural condition on Agree.

2.1. A dominance requirement on Agree

I propose to replace Chomsky's requirement that the Probe must c-command the Goal, by the requirement that the Probe must dominate the Goal. This dominance requirement is given in (5).

- (5) DOMINANCE REQUIREMENT ON AGREE:
The Probe must dominate the Goal

Given that c-command is defined in terms of dominance, dominance is a more primitive relation than c-command. Dominance is not defined in terms of yet another syntactic relation. Hence, it is not only more primitive than c-command, but it is simply a primitive syntactic relation (see McCawley (1968), Higginbotham (1985) and Speas (1990)).⁴⁵ Therefore, the dominance requirement on Agree in (5) has the advantage that it is theoretically simpler than Chomsky's c-command requirement. However, does the dominance requirement make the correct predictions about the configurations in which agreement takes place?

At first sight, the dominance requirement in (5) seems to predict that agreement is never possible. Probes are normally taken to be heads, and heads are terminal nodes. The defining characteristic of terminal nodes is that they do not dominate other nodes. Under this scenario, Probes do not dominate anything. Hence, the dominance requirement in (5) seems to predict that Agree can never be established and that agreement is therefore impossible. Given the agreement phenomena in natural language, this cannot be right. Hence, it looks like the dominance requirement is not a successful alternative to the c-command requirement. However, this conclusion is premature. I will show that under Bare

⁴ McCawley (1968), Higginbotham (1985) and Speas (1990) take the dominance relation to be one of the defining properties of syntactic structure. Intuitively, dominance can be defined as in Chomsky (1955) as the converse of a 'is a' relation. Formally, Higginbotham (1985: 89) defines dominance by the following axioms.

- (i) a. REFLEXIVITY
 x dominates x
b. TRANSITIVITY
if x dominates y , which dominates z , then x dominates z
ANTISYMMETRY
If x dominates y , which dominates x , then x is y
d. NO MULTIDOMINANCE
if x dominates z and y dominates z , then x dominates y or y dominates z

I refer the reader to Speas (1990: 18-24) for a clear discussion of these axioms.

⁵ Stepanov (2001: 101) restricts the dominance relation as in (i).

- (i) α is dominated by β only if it is dominated by every segment of β

The restriction in (i) has the effect that adjuncts are not dominated by an XP node of the category to which they are adjoined. Given that (i) is an additional stipulation to the theory, I will not adopt it in what follows.

Phrase Structure, the dominance requirement makes the prediction that agreement can be licensed in syntactic configurations involving dominance.

2.1.1. Dominance and Bare Phrase structure

The core of the problem for the dominance requirement mentioned above is the assumption that only heads are Probes. However, this assumption does not hold under Bare Phrase Structure (BPS) (Chomsky 1995, 2000, 2001). One of the consequences of BPS is that non-heads can also be Probes, as pointed out in Rezac (2004: 105).⁶ This becomes evident if one combines two aspects of Bare Phrase Structure. The first aspect concerns the way in which the label of a syntactic object is determined. The BPS-view on labeling is that the label of a syntactic object is identical to the head of that syntactic object (Chomsky 2000: 133-134, 2001:3). This means that if a syntactic object with label X is merged with a syntactic object with label Y, the newly formed syntactic object will have label X, if X is the head, and label Y if Y is the head, (6).⁷

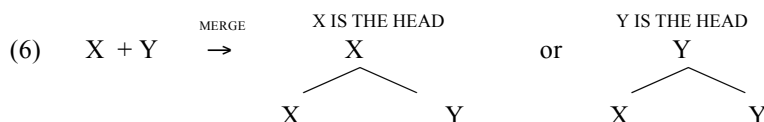

The second aspect of Bare Phrase Structure that is relevant for the present discussion is Chomsky (2000, 2001)'s proposal that probing features are part of the label of a syntactic object:

‘Suppose that L has generated the syntactic object K with label LB(K). On minimalist assumptions, LB (K) is the only element that is immediately accessible to L, so LB(K) must be the element that activates Agree, by virtue of its uninterpretable features: it is these that constitute the probe that seeks a matching goal –another collection of features– within the domain of LB(K).’
(Chomsky 2001: 5) (see also Chomsky 2000: 134-135)

The combination of the BPS-view of labeling with Chomsky's proposal that probing features are situated in labels has as a result that non-terminal nodes can be Probes. Consider for instance a syntactic object whose head, H, is a Probe. Under Chomsky's proposal, this actually means that the unvalued features that constitute the Probe are contained in the label of H. Under the BPS-view of labeling, all the syntactic objects that have H as their head have the same label as H. Syntactic

⁶ Rezac (2004) briefly mentions the possibility of non-terminal nodes being Probes as a consequence of Bare Phrase Structure. However, he does so without detailed argumentation. Below, I will provide his proposal with a more detailed motivation.

⁷ In order for it to work, the labeling algorithm has to know which of the merged syntactic objects constitutes the head. Chomsky (2000: 133) identifies the head with the syntactic object whose selectional requirements motivate merge. In that way, the label of a syntactic object formed by merge is that of the syntactic object that triggered merge. For a more detailed discussion of labeling, I refer the reader to Chomsky (2000, 2001) and Collins (2002).

objects are labeled at their topmost node. Therefore, the topmost nodes of the syntactic objects of which H is the head receive the same label as the head H. As this label contains probing features, these nodes are also Probes. In this way, each node that receives the label of a head that is a Probe forms a Probe itself. Therefore, a non-terminal node is a Probe as long as it is part of the projection of an unsatisfied Probe. This is illustrated in (7). In the derivation of the syntactic structure in (7), the head H is first merged with ZP in order to satisfy selectional requirements of H. The result of this merge operation is a syntactic object whose topmost node receives the label of the head H, because H is the projecting head given that it is the selector (see fn. 7). Because the label of H contains unvalued features, the topmost node is now also a Probe. After this, YP is merged to satisfy some of the features of H. This again results in a syntactic object with the label of H, turning the node that dominates YP into a Probe.

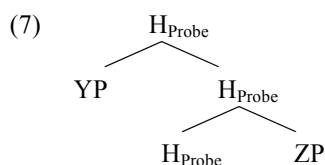

I adopt this view that non-terminal nodes are Probes, when a terminal node that is a Probe determines their label.

Unlike terminal nodes, non-terminal nodes dominate other nodes. Therefore, the dominance requirement on Agree predicts that Agree can be established when a non-terminal node that is a Probe dominates a suitable Goal. I will now examine in detail the syntactic configurations in which this requirement is met.

2.1.2. Predictions of the dominance requirement

Under the BPS-view presented above, there are two configurations in which a Probe on a non-terminal node can dominate a Goal:

- CONFIGURATION 1: The Goal is or is contained in the complement of the head that introduced the Probing features
- CONFIGURATION 2: The Goal is or is contained in the specifier of (or an adjunct to the projection of) the head that introduced the Probing features

The dominance requirement on Agree that I presented above in (5) predicts that Agree is possible in these two configurations.⁸ I will now discuss each configuration in more detail.

In the first configuration, the Goal is contained in the complement of the Probing head. This is for instance the case in (8), in which the Goal is contained in the complement, YP of a probing head H.

⁸ The predictions of the c-command requirement are discussed in section 2.2 below.

(8) CONFIGURATION 1

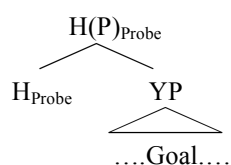

Under the BPS-view of labeling, the node that is created by merge of the head H and its complement YP has the same label as H. For this reason, it is also a Probe. This newly created node dominates YP, the constituent that contains the Goal. Hence, the structural condition on Agree imposed by the dominance requirement is met: the Goal in YP is dominated by a Probe. Hence, the dominance requirement predicts that Agree between the top node in (8) and the Goal in YP is possible, as in (9).

(9) CONFIGURATION 1

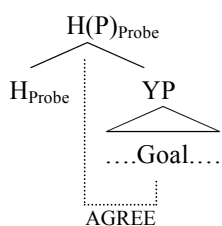

In the second configuration, the complement of the Probe does not contain any suitable Goal. However, its specifier, or a constituent adjoined to the projection of the Probe, does. This is illustrated in (10), in which a Goal is contained in ZP, a specifier of the Probe H.

(10) CONFIGURATION 2

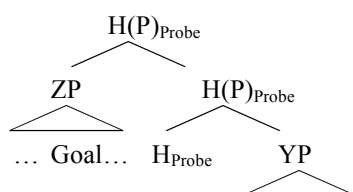

In this case, the dominance requirement predicts that Agree can be established, just like in the first configuration. First, the node that is created by merge between H and its complement YP is also a Probe because of the BPS-view of labeling. This is the same as in the first configuration. However, the difference with the first configuration is that no Agree-relation can be established at this point of the derivation. The reason for this is that YP does not contain a suitable Goal. Next, the

specifier ZP is merged in order to satisfy some feature of H. Again, the node that is created by this instance of merge will receive the label of the head H and hence is also a Probe. This newly created node dominates ZP and hence also the Goal contained in ZP. Given the dominance requirement, Agree between this node and the Goal takes place, as in (11).

(11) CONFIGURATION 2

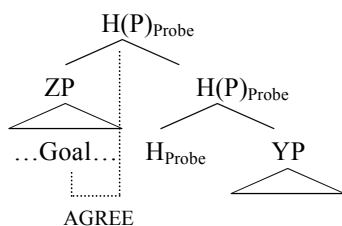

The dominance requirement thus predicts that agreement is possible when the Goal is either in the complement or the specifier of the Probe or in a constituent adjoined to a projection headed by the Probe.⁹ Below, I will compare these predictions with those made by the c-command requirement and examine which ones are borne out by looking at actual agreement phenomena.

2.1.3. Agree: BPS, spell-out and derivational syntax

Before I can start comparing the predictions made by the dominance requirement with those of the c-command requirement, I have to further specify some aspects of Agree under the dominance requirement and Bare Phrase structure. I will first discuss how the BPS-view of labeling can be implemented derivationally. I then discuss how Agree relations are spelled out under the dominance requirement. Finally, I will examine what happens in situations in which both the complement and the specifier of a Probe contain a Goal.

2.1.3.1 Bare Phrase Structure and label sharing

In section 2.1.1 above, I introduced the BPS-view of labeling. Under this view, the label of a syntactic object is identical to the label of the head of that syntactic object (Chomsky 2000: 133-134, 2001:3). Thus, merge between a head with label X and a complement YP results in a new syntactic object with label X. However, I did not discuss the way in which labeling takes place during the syntactic derivation. I

⁹The dominance requirement is therefore equivalent to an m-command requirement, i.e. that the Probe must m-command the Goal. However, m-command (Chomsky 1986, Aoun & Sportiche 1983) is abandoned in recent minimalist theory as a syntactic relation (Chomsky 1995:213, n.9, Epstein 1999: 322) (for reasons unclear to me). For this reason, I keep the formulation in terms of dominance instead of using m-command.

suggest that the BPS-view on labeling should be implemented through means of sharing of the label. Under this label-sharing view, a head shares (one instance of) its label with all the nodes that are projections of that head. Under this view, the label of a syntactic object is identical to the label of the head, because they share one and the same label. In the case of merge between a head with label X and a complement YP, a single label X would therefore be shared between the head and the newly created node, as in (12).¹⁰

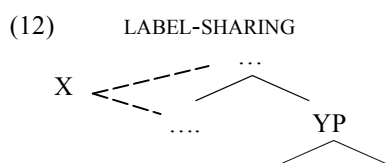

This sharing of labels is similar to notion of the sharing in the feature sharing view on agreement (Frampton & Guttman 2000, 2006, Pesetsky & Torrego 2004, Adger 2007, see also chapter 4). In both cases, features are shared between different syntactic nodes. In the case of agreement, this involves only a subset of the features of the labels of the nodes concerned, like for instance the gender and number features. In the case of labeling, all the features that together form the label of a node are shared with another node.

The obvious alternative to the label-sharing view presented above would be to derive the BPS-view of labeling through the copying of labels, as in (13).

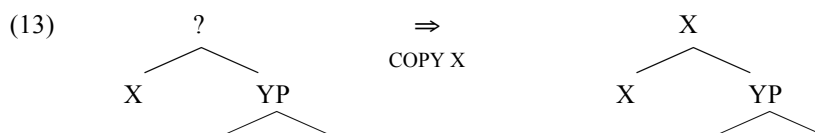

In that case, the label of a syntactic object is identical to its head, because the label of the syntactic object is a copy of that head. However, such an approach suffers from the drawback that the identity of the labels cannot be assured after copying takes place. In principle, a copied label might be altered through syntactic operations (Merge (selection), Agree, etc) after it was copied from its source. In that case, the labels on nodes of the same projections can become non-identical. This causes a problem at the interfaces, because some of the nodes of the same projection will still have unsatisfied features. The label-sharing view does not have this problem. Under the label-sharing view, all nodes of the same projection share the same label. If a syntactic operation alters this label, all the nodes of the projection in question will be associated with the altered label.

Although I adopt the label-sharing view of projection in what follows, I will not indicate label-sharing when it is not necessary for the discussion. The reason for this is that label-sharing would unnecessarily complicate the tree diagrams. Instead,

¹⁰ David Pesetsky (personal communication) says he always understood the BPS-notion of labeling to involve a notion that is identical to label sharing and that this is also Chomsky's (1995) intent.

I will use the more conventional notation and label each node in a projection separately.

2.1.3.2 The spell-out of Agree-relations

Agree-relations are rendered visible by agreement morphology on the Probe. As argued above, the dominance requirement predicts that Agree is possible in two cases. The first one is when a Goal is contained in the complement of a Probe, as in (9) above. The second one is when a Goal is contained in the specifier of a Probe, as in (11). In both cases, it is not the head that enters into Agree with the Goal, but a projection of that head. This is problematic given the distributed morphology model that I adopted in chapter 2. In this model of the grammar, only terminal nodes can be spelled out (Halle & Marantz 1993). Therefore, agreement morphology should also be the result of the spell-out of a terminal node. However, the Probe that establishes Agree with the Goal in (9) and (11) is a non-terminal node. Hence, the spell-out of this Agree-relation seems to require the spell-out of a non-terminal node instead of a terminal one. The dominance requirement thus seems to face a problem with the spell-out of the Agree relation. This problem is however only apparent under the label-sharing view of projection that I just introduced.

Under the label-sharing view, a head and those non-terminal nodes that are projections of the head share one and the same label. If this label has unvalued features, it is a Probe. If one of the non-terminal nodes that are associated with this label dominates a Goal, Agree will be established and the unvalued features in the label will be valued. As the label is also associated with the head of the projection, the valuation of features can be spelled out as agreement morphology on a terminal node. In this way, there is thus no problem for spell-out.

In order to make this more concrete, consider a situation in which a head with label X that contains an unvalued number feature is merged with a complement YP that contains a potential number goal, as in (14a). This is an instantiation of the first configuration discussed in section 2.1.2. After merge between X and YP, the new syntactic object shares its label with that of the head, as in (14b). Hence, the node that is created by merge is also associated with a label that contains an unvalued number feature. It is therefore a number Probe. This node dominates YP which contains Z. Z has a valued number feature and hence is a suitable Goal for number. This means that the dominance requirement is met. As a consequence, Agree is triggered between the top node and Z. This leads to valuation of the number-feature in the label of the top node (14c). As this label is shared between the head and the top node, the number feature that got valued under Agree can be spelled out on the head. The head is a terminal node, hence, the core assumption of distributed morphology that only terminal nodes are spelled out is observed.

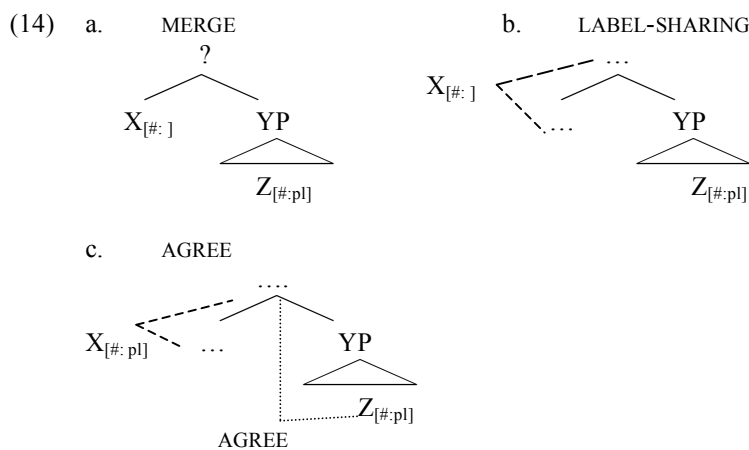

In this way, label-sharing permits Agree to be triggered via a non-terminal node, while its results are spelled out on a terminal node.

2.1.3.3 The Earliness Principle

After clarifying how Agree-relations are spelled out if Agree is subject to a dominance requirement, I will now address the issue of what happens in case both the specifier and the complement contain a Goal.

Above, I argued that the dominance requirement predicts that Agree is licensed in two different configurations. The first configuration arises when the Goal is in the complement of the Probe, the second one when the Goal is in the specifier of the Probe. In principle, these two configurations can be combined. In that case, the Probe would have a potential Goal both in its complement and in its specifier, as in (15).

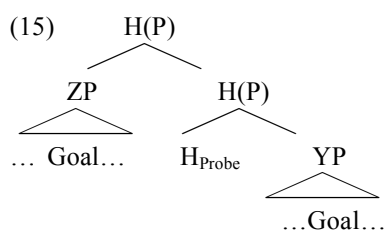

Given that it predicts that Agree is possible between a Probe and a Goal in the complement or in the specifier, one might have the impression that the dominance requirement predicts that Agree is in principle possible with both Goals in (15). However, I claim with Rezac (2003, 2004) that this is not the case and that Agree with the Goal in the specifier of (15) is bled by the presence of a Goal in the com-

plement.¹¹ I will follow Pesetsky & Torrego (2001) & Rezac (2003, 2004) and propose that Agree is constrained by the Earliness Principle in (16), a natural general derivational constraint.

- (16) EARLINESS PRINCIPLE
 Probes needs to be satisfied/valued as early in the derivation as possible
 (cf. Pesetsky 1989; Chomsky 1995; Richards 1997; Pesetsky & Torrego 2001; Rezac 2003, 2004)

Basically, the Earliness Principle states that Agree is obligatory when its structural description is met. If a Probe is in the right configuration with a Goal, Agree is established. Formulated differently, a Probe cannot look for another Goal, if it has already found one. A Probe thus does not have the liberty to choose any Goal. It just enters into Agree with the first Probe it finds in its search domain. In the case of (15), this forces the Probe to enter into Agree with the Goal in the complement. This bleeds Agree between the Probe and the Goal in the specifier. In order to illustrate this, I will now discuss in detail how the syntactic derivation of (15) proceeds.

In (15), H first merges with the complement YP. The result is an instance of the first configuration discussed in section 2.1.2. Under the BPS-view of labeling, the node created by this merge, will receive the same label as the head H. Hence, this node is a Probe. In addition, it dominates YP, which contains a Goal. Given the dominance requirement, Agree can thus be established. This is the point in the derivation in which the Earliness Principle plays a role. The Earliness Principle dictates that Agree must be established at this point. Hence, Agree is established, as in (17).

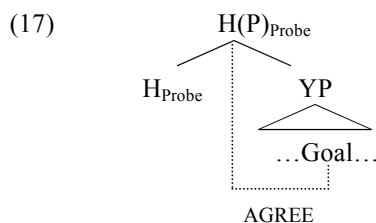

However, Agree is not without consequences. It values the unvalued feature(s) in the Probe. It hence deactivates the label of the top node as a Probe. Under the view that labels are shared by the different nodes of the same projection (see section 2.1.3.1 above), the label of the top node in (17) is shared with the head. Given that Agree deactivates the label as a Probe, the head also ceases to be a Probe, as in (18).

¹¹ Rezac (2003, 2004) makes this claim for Agree under the c-command requirement. Here, I will do the same for Agree under the dominance requirement.

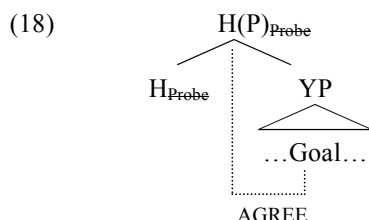

Next, the specifier ZP is merged with the structure in (18). Given the BPS-view on labeling, the node that is created by this application of merge receives the same label as the head H. However, this label no longer contains unvalued features. The unvalued features that it contained previously were already valued under Agree with the Goal contained in the complement. Hence, the node that dominates the specifier ZP does not constitute a Probe. Hence, there is no Probe that dominates the potential Goal in ZP, and Agree is therefore not established.

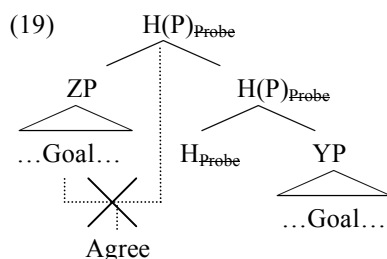

The Earliness Principle thus predicts that the presence of a Goal in the complement of a Probe deactivates the Probe and bleeds Agree between the Probe and a Goal in the specifier of the Probe (cf. Rezac's (2003) notion of cyclic Agree). Below, we will see that this prediction is borne out in Georgian in the case of verbal person agreement.

2.1.4. Summary

Above, I proposed an alternative to the c-command requirement in the form of a dominance requirement. The dominance requirement predicts that Agree is established either when the Goal is in the complement of the Probe or when it is in the specifier of the Probe. When both the specifier and the complement of the Probe contain a Goal, the dominance requirement in combination with the Earliness Principle predicts that Agree is only established with the Goal in the complement.

Before examining whether these predictions are actually borne out by the data, I will first specify the predictions made by the c-command requirement about the configurations in which Agree can be established. This will allow me to compare the dominance requirement with the c-command requirement with respect to the predictions they make. I will then examine some agreement phenomena in order to decide which of these requirements is the most empirically adequate one.

2.2. C-command

In order to compare the predictions made by the dominance requirement with those of the c-command requirement, I examine here the predictions made by the c-command requirement in full detail. However, I will first show that the two versions of the c-command requirement presented in Chomsky (2000) are not equivalent, contrary to the way in which they are presented in Chomsky (2000). This entails that Chomsky (2000) actually presents two different c-command requirements. I will then specify in detail the predictions each requirement makes. In that way, I will be able to compare them with the dominance requirement.

2.2.1. Chomsky (2000): two different structural conditions on Agree

As mentioned in the introduction, Chomsky (2000:122) proposes that Agree can only be established if the Goal is contained in the sister of the Probe, i.e. if the Probe c-commands the Goal, (20).

- (20) C-COMMAND REQUIREMENT VERSION I
The Probe must c-command the Goal. (Chomsky 2000: 122)

A bit further in the same article, Chomsky reformulates the c-command requirement as follows: ‘...[the] G[oa]l must be in the complement of the Probe P, not in its specifiers ...’ (Chomsky 2000: 135). This version of the c-command requirement is given in (21).

- (21) C-COMMAND REQUIREMENT VERSION II
The Goal must be in the complement of the Probe.
(Chomsky 2000: 135)

Chomsky presents these two versions as being notational variants. At first sight, these two versions seem to be just that: different formulations of the same requirement. A head c-commands everything in its complement. So if the head in question is a Probe and its complement contains a Goal, the Probe c-commands the Goal. However, Rezac (2003, 2004) accurately points out that these two formulations are far from equivalent under Bare Phrase Structure. In this section, I will examine these two versions of the c-command requirement and explain why they are different.

The reason why the two versions in (20) and (21) are not equivalent is that Probes can c-command syntactic objects that are not complements under BPS. Rezac (2003: 158, 2004: 102) shows that version I of the c-command requirement predicts under Chomsky’s own Bare Phrase Structure that Agree is possible between a Probe and a Goal that is contained in the specifier of the Probe. However, the version in (21) does not allow for this. As discussed in section 2.1 of this chapter, there are two aspects of Bare Phrase Structure that are relevant for Agree. The first one is that the label of a syntactic object is identical to that of the head of the syntactic object in question. The second one is that the unvalued features that make a syntactic node a Probe are part of the label of that node. As a consequence, the node that is formed by

merging a Probe and its complement also constitutes a Probe (see section 2.1 above), as in (22).

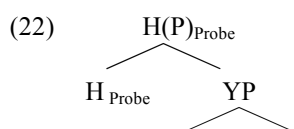

When a specifier is added to (22), the specifier will be a sister to the top node in (22). Given that the top node in (22) is a Probe under the assumption that the projection of a Probe is also a Probe, the specifier will be c-commanded by a Probe. Therefore, if the specifier contains a Goal, Agree as in (23) should be possible under version I of the c-command requirement.

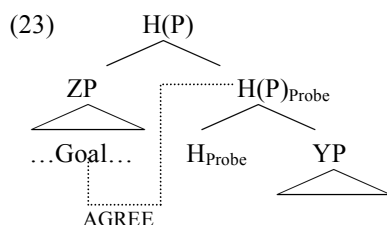

Under the second version of the c-command requirement, Agree is not permitted in (23). In (23), the Goal is contained in a specifier, not in a complement. The two versions of the c-command requirement in (20) and (21) thus make different predictions under Bare Phrase Structure. Despite that Chomsky presents as notional variants, they are thus not equivalent formulations of one and the same requirement. They are different requirements. In order to keep the two requirements apart, in what follows, I will refer to the requirement in (20) as the c-command requirement on Agree, as in (24), and to the requirement in (21) as the complement requirement on Agree, as in (25).

(24) C-COMMAND REQUIREMENT
The Probe must c-command the Goal. (Chomsky 2000: 122)

(25) COMPLEMENT REQUIREMENT
The Goal must be in the complement of the Probe. (Chomsky 2000: 135)

Which of the two requirements proposed in Chomsky (2000) must be preferred? Taking theoretical complexity into consideration, it seems that the c-command requirement on Agree must be preferred to the complement requirement. Rezac (2003: 158; 2004: 102) points out that the complement requirement constitutes a ‘questionable stipulation’, because it refers to the notion of complement. According to him, ‘complements [...] are not privileged under BPS’ (Rezac 2003: 158). By this, Rezac probably means that it is difficult in BPS to define complements in such a

way that they are distinguished from specifiers. However, he does not go into very much detail of why this is so. Below, I will try to fill this gap in Rezac's argumentation and demonstrate in detail why the reference to complements is undesirable in BPS.

The notion of complement is not a primitive of syntactic theory under Bare Phrase Structure. It should therefore be defined in more primitive syntactic notions. However, such a definition gets rather complicated in order to distinguish complements from specifiers. In (26), such a definition is given.

- (26) BPS DEFINITION 'COMPLEMENT'
 Y is the complement of X, iff
- a. Y is a sister of X, i.e. Y and X c-command each other
 - b. X selects for Y
 - c. X is a terminal node

In this definition, (26a) and (26b) are self-explanatory. Complements are selected syntactic objects that are merged with their selectors. After Merge, they will be sisters of their selectors. The clause in (26c) is the one needed in order to set apart complements from specifiers. Like complements, specifiers can also be selected syntactic objects. Under BPS, we cannot distinguish between complements and specifiers on the basis of sisterhood to the selector, i.e. clauses a and b of the definition in (26). If one does not assume BPS, one might claim that complements are selected syntactic objects that are sisters to their selector, the selecting head, while specifiers are selected syntactic objects that are not sisters of their selector, the selecting head. However, the label of the syntactic object with which the specifier is merged is identical under BPS to that of the label of the head with which the complement is merged. This label contains the selectional features. Hence, both specifiers and complements are sisters of their selector. Therefore, (26a) and (26b) do not permit to distinguish between complements and specifiers. Thus, (26c) is needed. Complements are the sister of a terminal node, while the sister of a specifier is a non-terminal node.

Under BPS, the notion of complement is thus rather complex demanding a definition in more primitive notions that consists of minimally three subparts (see the discussion of (26) above). Given this theoretical complexity, the complement condition is rather suspicious. However, the question whether this theoretical complexity is justified is by and large an empirical one. If Agree is only established in cases in which the Goal is in the complement of the Probe, empirical adequacy justifies the theoretical complexity of the complement condition. In order to determine the empirical adequacy of both the complement and the c-command requirement, I will now examine the predictions made by both these requirements. This will also allow me later on to compare Chomsky's (2000) requirements with the dominance requirement.

2.2.2. Predictions of the complement and the c-command requirement

In theory, there are three different Probe-Goal configurations in which the c-command requirement predicts that Agree is possible. These include the following:

- CONFIGURATION 1: The Goal is or is contained in the complement of the Probe
- CONFIGURATION 2: The Goal is or is contained in the specifier of (or an adjunct to) the Probe
- CONFIGURATION 3: The Probe is a specifier or adjunct and the Goal is contained in the sister of this specifier or adjunct.

The complement requirement on the other hand predicts that Agree is only possible when the Goal is in the complement of the Probe, as in configuration 1. I will now briefly examine each of these configurations and explain the predictions made by the complement and c-command requirement in each case.

In the first configuration, the Goal is contained in the complement of the Probe, as in (27).

(27) CONFIGURATION 1

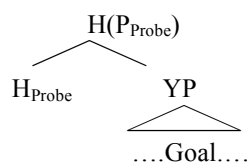

Both the complement and the c-command requirement predict that Agree is possible in this case. Given that a head c-commands its complement, the Probe in (27) c-commands the Goal. Hence, the c-command requirement is met. In addition, the Goal is not contained in a specifier, but in a complement. For this reason, the complement requirement is also satisfied.

In the second configuration, the goal is contained in the specifier of the probe, as in (28).

(28) CONFIGURATION 2

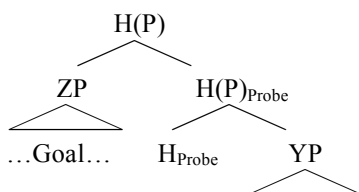

This is the configuration that I discussed in section 2.2.1. In that section, I showed, following Rezac, that the complement condition and the c-command requirement make different predictions. The complement requirement predicts that Agree is

impossible in this configuration. The reason for this is that Agree between a Probe and a Goal in the specifier of the Probe is stipulated to be impossible under this requirement (see the definition in (20) above). The c-command requirement on the other hand predicts that Agree is possible. The sister node of the specifier ZP is a Probe under the BPS view of labeling. This node c-commands the specifier ZP. Hence, the Goal in ZP is c-commanded by a Probe. Hence, the c-command requirement is met.

The third configuration consists of a Probe that is a specifier or adjunct and a Goal that is contained in the sister of the Probe. Unlike configuration 2, this is a configuration that is not discussed in Rezac (2003, 2004). This configuration is illustrated in (29).

(29) CONFIGURATION 3

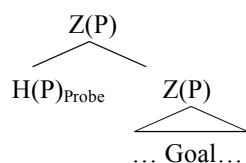

In this case, the complement and the c-command requirement differ in their predictions. The c-command requirement predicts that Agree is possible. The specifier in (29) is a Probe. The sister of this specifier contains a Goal. Hence, the Probe c-commands the Goal. Therefore, the c-command requirement is met. This is not the case for the complement requirement. The Goal in (29) is not contained in the complement of the Probe. Hence, the complement requirement predicts that Agree is impossible in this case.

The c-command requirement is thus the more liberal one of the two requirements. It allows for Agree to be established in all three possible configurations that I discussed above. The complement requirement on the other hand only allows Agree to be established in configuration 1 above, i.e. when the Goal is in the complement of the Probe. These predictions of the two requirements are summarized in the table in (30).

(30) PREDICTIONS OF THE C-COMMAND AND COMPLEMENT REQUIREMENTS

Configuration	Description	C-command requirement	Complement requirement
1	G in complement of P	√	√
2	G in specifier of P	√	*
3	P specifier or adjunct, G in sister of P	√	*

Before I examine whether the predictions made by the c-command and complement requirement are borne out by the agreement data, I first compare these two requirements with the dominance requirement.

2.3. Three candidates for the structural condition on Agree

Above, I discussed three different candidates for the structural condition on Agree: the dominance requirement, the c-command requirement and the complement requirement. I showed that these three requirements make different predictions about the configurations in which Agree can arise. These predictions are summarized in the table in (31).

- (31) PREDICTIONS OF THE COMPLEMENT (COMPL.), DOMINANCE (DOM), AND C-COMMAND (C-COM) REQUIREMENTS (P=Probe, G=Goal)

Configuration	Description	Compl.	Dom.	C-Com
1	G in complement of P	✓	✓	✓
2	G in specifier of P	*	✓	✓
3	P specifier or adjunct	*	*	✓

Of the three candidates, the c-command requirement allows for Agree to be established in the largest number of configurations. As I showed in section 2.2.2, this requirement predicts that Agree can be established in three different configurations. These three configurations are defined as follows. In the first configuration (referred to as configuration 1 in (31)), the Goal is in the complement of the Probe. The second configuration, configuration 2 in (31), is characterized by the Goal being in the specifier of the Probe. The final configuration, configuration 3 in (31), is defined by the Probe forming a specifier or adjunct, while the Goal is contained in the sister of the Probe.

The dominance requirement predicts that Agree can only be established in configurations 1 and 2, as discussed in section 2.1.2. It predicts that Agree is impossible in the case of configuration 3. The reason for this is that the Probe does not dominate the Goal when the Probe is a specifier or adjunct and the sister of this specifier or adjunct contains the Goal. This is illustrated in (32), which corresponds to the representation of this configuration in (29) above.

(32) CONFIGURATION 3

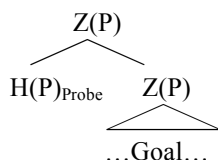

Finally, the complement requirement predicts that the number of configurations in which Agree can be established is limited to only one. According to this requirement, Agree can only be licensed when the Goal is in the complement of the Probe, as in configuration 1 in the table in (31).

The three requirements are not only different with respect to their predictions. They also differ in theoretical complexity. The dominance requirement is the simplest candidate. The reason for this is that it is directly stated in terms of the primitive syntactic relation of dominance. The c-command requirement is theoretically more complex than the dominance requirement. The reason for this is that c-command is not a primitive syntactic relation, because it is defined in terms of another syntactic relation, dominance (see the introduction of this chapter). The third candidate for the structural condition on Agree, the complement requirement, is also theoretically more complex than the dominance requirement. The reason for this is that it also contains a c-command requirement. This requirement is part of the definition of the notion ‘complement’. In section 2.2.1, I showed that this notion requires a definition like the one in (26), repeated here as (33).

- (33) BPS DEFINITION ‘COMPLEMENT’
 Y is the complement of X, iff
- a. Y is a sister of X, i.e. Y and X c-command each other
 - b. X selects for Y
 - c. X is a terminal node

The c-command requirement is stated in (33a). Y can only be as complement of X if X c-commands Y. Moreover the complement requirement is even more complex than the c-command requirement. This is so because the definition of complement requires the additional stipulations in (33b) and (33c), besides the c-command requirement in (33a). Given these additional stipulations, the complement requirement is theoretically far more complex than the c-command requirement. This makes the complement requirement theoretically the most complex of the three candidates for the structural condition on Agree. In (34), the three requirements are ordered in terms of complexity.

- (34) Theoretical complexity
 DOMINANCE < BPS C-COMMAND < COMPLEMENT

Which of the three requirements is the most adequate formulation of the structural condition on Agree? In principle, the candidate whose predictions are the most

accurate should of course be preferred to the other candidates. In the following three sections, I will therefore examine whether the predictions made by each requirement are actually borne out by the data. I will show that this permits me to exclude one of the three candidates. However, it does not allow me to decide between the remaining two candidates. These seem to be to the same extent successful in predicting the configurations in which Agree occurs. Formulated differently, the remaining two candidates have the same empirical adequacy. This is where the discussion about theoretical complexity and its outcome in the form of the scale in (34) become useful. Occam's razor dictates that the simpler requirement of the two, i.e. the one which definition requires fewer assumptions, should be preferred. Therefore, the preferred requirement will be the one who is leftmost on the scale in (34).

3. Configuration 1: the Goal in the complement of the Probe

I will now examine whether the predictions made by the three different candidates for the structural condition on Agree are borne out by the data. In section 2, I discussed these predictions for the three different configurations. I referred to these configurations as configurations 1, 2, and 3. Configuration 1 is the subject of this section, while the other configurations are discussed in the following two sections.

Configuration 1 consists of a Goal that is contained in the complement of the Probe. This configuration was illustrated in (8) and (27) above, repeated here in (35).

(35) CONFIGURATION 1

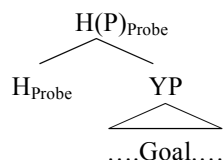

Among the three different candidates for the structural condition on Agree, this configuration is the least interesting one among the three configurations. The reason for this is that all three requirements predict the same in this configuration. Hence, examining this configuration will not help me choose among the different requirements. Therefore, I will only briefly discuss here whether the predictions concerning this configuration are borne out or not.

The dominance requirement, the c-command requirement and the complement requirement all predict that Agree is possible in this configuration (see the table in (31) and the discussion in sections 2.1.2 and 2.2.2 above). This prediction is borne out. It is even the case that the majority of canonical cases of agreement are generally considered to take place in this configuration. Consider for instance subject-verb agreement, as in the English example (36a). In this example, the verb *chases* agrees in person and number with the third person singular subject *the kitten*. The standard view about subject-verb agreement is that the agreement

morphology on the verb is the reflection of a phi Probe on T, that enters into Agree with the subject in spec vP, as in (36b) (Chomsky 2000, 2001).

- (36) a. *The kitten chases the ball.*
 b.

Hence, subject-verb agreement is an instantiation of configuration 1: the subject, the Goal, is contained in vP, which is the complement of T, the Probe. As mentioned above, all three different requirements correctly predict that Agree can be established in this configuration. The reason for this is that the complement requirement and the c-command requirement, as well as the dominance requirement are met. In order to illustrate this, I will briefly specify why each requirement is met in this case. The complement requirement is met, because the subject is contained in vP, the complement of the Probe T. The c-command requirement is met because the Probe T c-commands the subject in spec vP. Finally, the node that is created by merge between T and vP has the same label as T. This node is therefore also a Probe. As this node dominates spec vP, the subject is dominated by a Probe. Hence, the dominance requirement is satisfied as well in the case of subject-verb agreement.

Although subject-verb agreement is one of the most common types of agreement, it is far from the only type in the literature that is licensed in configuration 1. Examples of other types of agreement that have been argued to also be licensed in configuration 1 are Complementizer Agreement (Van Koppen 2005) and Long Distance Agreement (Potsdam & Polinsky 2001).

4. Configuration 2: Goal in spec Probe

Although the three competing requirements for the structural condition on Agree all predict that Agree is possible in configuration 1, this is not the case with respect to configuration 2. In this configuration, the complement requirement predicts something else from the other two requirements. I discussed this in detail in section 2. In this section, I will examine person agreement in Georgian to check empirically whether these predictions are borne out or not. In order to facilitate the discussion, I will briefly recapitulate here the predictions made by each of the three requirements.

As specified in section 2, the Goal in configuration 2 is in the specifier of the Probe. I argued that the complement requirement predicts that Agree cannot arise in this configuration. The reason for this is simple. Contrary to what is required by the complement requirement, the Goal in configuration 2 is not contained in the complement of the Probe. The complement requirement is thus not met and

therefore Agree is predicted to be impossible. The c-command requirement and the complement requirement on the other hand make the opposite prediction, as they are both satisfied. The c-command requirement is met because the sister of the specifier of a Probe is a Probe under BPS. Therefore a Probe c-commands the Goal in ZP. The dominance requirement on the other hand is satisfied because the mother node of a specifier of a Probe is also a Probe under BPS. Therefore, the Goal in the specifier is dominated by a Probe. The predictions of each requirement for configuration 2 are summarized in the table in (37).

(37) PREDICTIONS MADE IN CONFIGURATION 2

Configuration	Description	Compl.	Dom.	C-Com
2	G in specifier of P	*	√	√

The complement requirement thus makes a prediction that differs from that of the other two requirements. This difference offers the possibility to test the empirical adequacy of the three candidates for the structural condition on Agree. If agreement between a Probe and a Goal in the specifier of the Probe does not occur in natural language, the prediction made by the dominance requirement and the c-command requirement is inaccurate. In that case, these two candidates for the structural condition on Agree should be abandoned in favor of the complement requirement. However, if the inverse is true, i.e. this kind of agreement is actually attested among the languages of the world, the c-command requirement should be abandoned in favor of the other two requirements. Below, I will argue, following Rezac (2003, 2004), that person agreement in Georgian favors this second scenario.

4.1. Person Agreement in Georgian (Rezac 2003, 2004)

As argued above, the complement requirement predicts that Agree cannot be established in configuration 2. Formulated differently, it predicts that the Goal cannot be in the specifier of the Probe. However, Rezac (2003: 160-164) argues that some otherwise mysterious instances of person agreement in Georgian should be analyzed as involving Agree between a head and its specifier. As pointed out by Rezac himself, person agreement in Georgian thus forms an empirical argument against the complement requirement. In order to show this, I review Rezac's analysis of Georgian in more detail.

In order to illustrate his proposals about Georgian agreement, Rezac gives the partial paradigm of the transitive verb *xedav* in the present tense. This paradigm is reproduced here in the table in (38).¹²

¹² Rezac omitted from this table the 1PL (subject and object) forms because they introduce 'irrelevant complications: [they] do not trigger plural morphology' (Rezac 2003:161, fn. 3)

- (38) VERBAL AGREEMENT IN GEORGIAN FOR TRANSITIVE *XEDAV* 'SEE' IN THE PRESENT (Rezac 2003: 161)

SUBJECT	OBJECT			
	1SG	2SG	2PL	3
1SG	–	g-xedav	g-xedav-t	v-xedav
2SG	m-xedav	–	–	∅-xedav ¹³
2PL	m-xedav-t	–	–	∅-xedav
3SG	m-xedav-s	g-xedav-s	g-xedav-t	xedav-s
3PL	m-xedav-en	g-xedav-en	g-xedav-en	xedav-en

As can be seen in (38), finite verbs in Georgian take both prefixes and suffixes. I will focus here on the prefixes, because they mark person according to Rezac (2003, 2004). The exponents for 1st person are *m-* and *v-*, while *g-* and *∅-* are the exponents for 2nd person.¹⁴ For discussion of the suffixes, I refer the reader to Rezac (2003, 2004) and Béjar (2000). Intransitive verbs inflect as transitive verbs with 3rd person objects, i.e. they take the same inflectional affixes as *xedav* in the last column of the table in (38). This is illustrated in (39). If it has a 1SG subject, the intransitive verb *k'vd* 'die' takes the same prefix *v-*, (39a), as the transitive verb *xedav* 'see' with a 1SG subject and a 3SG OBJ, (39a).

- (39) a. *v-k'vd-eb-i* INTRANSITIVE, 1SG SUBJ
 1-die-X-PRES.IND¹⁵
 'I am dying' (Rezac 2003: 163)
- b. *v-xedav* TRANSITIVE, 1SG SUBJ, 3SG OBJ
 1-see
 'I see him' (Rezac 2003: 161)

Based on these observations, Rezac (2003, 2004) proposes the following generalizations about person agreement in Georgian. If the internal argument is 1st or 2nd person, the verb agrees with the internal argument. This results in the licensing of the *m-* prefix on the verb in case the internal argument is 1st person or in the licensing of the *g-* prefix if the internal argument is 2nd person. If the internal argument is however 3rd person or if there is no internal argument, person agreement on the verb is with the external argument. This agreement licenses the *v-* prefix on the verb if the external argument is 1st person and the *∅-* prefix if it is 2nd person. These generalizations are summarized in (40) and illustrated in (41) with some examples from the table in (38) and the example in (39a).

¹³ Rezac distinguishes a zero prefix, occurring on the verb in case the object is 3rd person and the subject is 2nd person, from the absence of prefix in case both the subject and object are 3rd person. The reason for this is that there is an overt allomorph in the former case, but not in the latter case. For more detailed discussion, see Rezac (2003: 161-162, fn. 4)

¹⁴ According to Rezac (2003: 161, fn. 4), the difference in form between *m-* and *v-* and that between *g-* and *∅-* is irrelevant for the discussion of person agreement.

¹⁵ The *X* in the gloss indicates a morpheme that is difficult to gloss, but whose gloss does not matter for the current discussion (Rezac 2003: 161, fn. 2)

- (40) REZAC'S (2003, 2004) GENERALIZATIONS
 Person agreement on Georgian verbs is licensed by the:
- Internal argument: if the internal argument is 1st, (41a), or 2nd person, (41b)
 - External argument: if the internal argument is 3rd person, (41c), or absent, as in (41d)
- (41) a. *m-xedav* 1ST P. OBJ.: OBJECT PERSON AGREEMENT
 1-see
 'You see me'
- b. *g-xedav* 2ND P. OBJ.: OBJECT PERSON AGREEMENT
 2-see
 'I see you'
- c. *v-xedav* 3RD P. OBJ.: SUBJECT PERSON AGREEMENT
 1-see
 'I see him'
- d. *v-k'vd-eb-i* NO OBJ.: SUBJECT PERSON AGREEMENT
 1-die-X-PRES.IND
 'I am dying'

Rezac explains the generalizations in (40) in the following manner. First, he proposes that the *v*-head is the only person Probe in Georgian. In case the internal argument is first or second person, the internal argument forms in principle a suitable Goal for Agree with *v*. The reason for this is that it is marked for person in that case. As it is also contained in the complement of *v* and hence is in the search domain of *v*, Agree between *v* and the internal argument is established, as in (42a). Secondly, Rezac adopts the view that 3rd person is actually the absence of person marking on a DP (cf. Benveniste 1966). Under this view, third person internal arguments do not constitute a suitable Goal for Agree with *v*, because they are not marked for person. As far as person agreement is concerned, this renders transitive verbs with a third person object similar to intransitive verbs as for example the one in (41d). In both cases, there is no internal argument with a person feature in the complement of *v* with which *v* can establish Agree. For this reason, Rezac proposes that the search domain of the Probe can be expanded to include the specifier of the Probe, if there is no suitable Goal in its complement. In the case of intransitive verbs and transitive verbs with a 3rd person internal argument, this means that the search domain of *v* is expanded to include spec *v*P. Spec *v*P contains the external argument. If the external argument is marked for person, i.e. is 1st or 2nd person, *v* enters into Agree with it, as in (42b).¹⁶

¹⁶ Note that the generalizations in (40) cannot be explained if T is taken to be the Person Probe instead of *v*. In that case, one would expect the following pattern: person agreement with the subject if it is 1st or 2nd person, no matter the person features of the object and subject agreement with a 1st or 2nd person object only if the subject is 3rd person.

- (42) a. 1P/2P OBJ: AGREE (v, OBJ) b. 3OBJ/NO OBJ: NO MATCH IN COMPL
OF v, AGREE (v, 1P/2P SUBJ), SUBJ.
IN SPEC vP

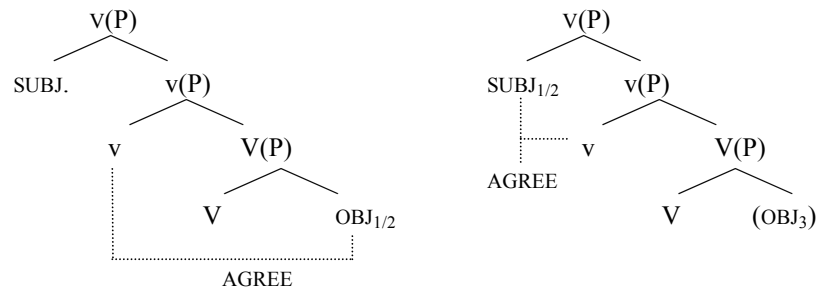

This analysis favors the complement over the specifier. A Probe can only enter into Agree with a Goal in its specifier if there is no Goal in the complement. Rezac attributes this to the Earliness Principle. I introduced this principle above in section 2.1.3.3. The definition of the Earliness Principle was given in (16), repeated here in (43).

- (43) EARLINESS PRINCIPLE
Probes needs to be satisfied/valued as early in the derivation as possible
(cf. Pesetsky 1989; Pesetsky & Torrego 2001; Rezac 2003, 2004)

As explained in detail in section 2.1.3.3, the Earliness Principle forces Agree to take place as early as possible. I showed in that section that this has the consequence that the presence of a Goal in the complement of the Probe bleeds Agree between the Probe and a Goal in its specifier. Person agreement in Georgian nicely illustrates this. In Georgian, the Earliness Principle forces v to enter into an Agree relation with a DP marked for person in its complement the moment the complement is merged. This instance of Agree deactivates v as a person Probe. As a consequence, further Agree is blocked between v and a DP marked for person in the specifier of vP. However, if the complement of v does not contain a DP marked for Person, v stays active as a person Probe until the specifier is merged. Only in that case, Agree between v and a DP in spec vP can be established.

Rezac's analysis offers an elegant account of person agreement in Georgian. It accurately predicts when the verb agrees in person with the internal argument and when it agrees with the external argument. However, Rezac's account is incompatible with the complement requirement on Agree. His analysis requires Agree between a Probe and a Goal in the specifier of that Probe in order to account for person agreement with the external argument. Formulated differently, it is essential in Rezac's analysis that Agree is possible in configuration 2. However, the complement requirement predicts that this kind of agreement is impossible. As seen above, the c-command requirement and the dominance requirement do not face this problem. They both predict that Agree is possible in configuration 2. They are there-

fore fully compatible with Rezac's analysis of the Georgian facts. Therefore, Georgian person agreement constitutes an argument against the complement requirement.

4.2. Conclusion

I argued above that the prediction made by the complement requirement that Agree can only take place if the Goal is in the complement of the Probe is not borne out, if one adopts Rezac (2003, 2004) analysis of Georgian person agreement. Under this analysis, *v* in Georgian enters into Agree with a DP in its specifier if its complement does not contain a DP marked for person. If one were to keep the complement requirement as a candidate for the structural condition on Agree, Georgian person agreement could not receive Rezac's analysis and thus would remain unexplained. This is undesirable given the empirical accuracy of Rezac's account. The c-command requirement and the dominance requirement on the other hand are fully compatible with Rezac's account, because they predict that Agree is possible in configuration 2. As we will see below, Agree between a Probe and a Goal in its specifier does not only account for person agreement in Georgian, but also for agreement on predicative adjectives in Swedish and Hungarian. For these reasons, I abandon the complement requirement as a candidate for the structural condition on Agree. In the following section, I will only consider the c-command requirement and the dominance requirement as candidates for the structural condition on Agree.

5. Configuration 3

In the previous section, I discarded the complement requirement as a candidate for the structural condition on Agree. There are now two candidates left to consider: the c-command requirement and the dominance requirement. In configurations 1 and 2, these two candidates make the same predictions, as I showed above (see especially the table in (31) above). However, they make different predictions about whether Agree can be established in configuration 3. In this configuration, the Probe is a specifier or adjunct, while the Goal is contained in the sister of this specifier or adjunct, as in (29) above repeated here as (44).

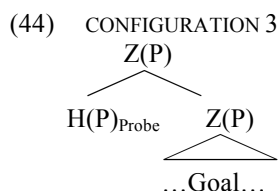

As shown in section 2, the c-command requirement predicts that Agree is possible in this configuration. The reason for this is that the Goal in (44) is contained in the

sister of the Probe. Hence, the Probe c-commands the Goal. The dominance requirement on the other hand predicts that Agree is impossible in this case. This is so because no (projection of a) Probe dominates the Goal in (44). These different predictions make configuration 3 the testing ground for deciding between the c-command requirement and the dominance requirement.

In this section, I will try to decide which of the two requirements is empirically more accurate. In order to do so, I will look for instances of configuration 3 in the domain of adjectival agreement. More specifically, I will look at symmetries and asymmetries in three European languages between attributive and predicative adjectives with respect to agreement. These languages are Swedish, Hungarian and French. The outcome of this investigation is unfortunately inconclusive. Some of the adjectival agreement phenomena that will be examined seem to favor the dominance requirement. However, another part of these phenomena seems to support the c-command requirement. I will first examine those phenomena that seem to support the dominance requirement and then those that support the c-command requirement.

5.1. Arguments in favor of dominance

As mentioned above, the dominance requirement predicts that Agree is impossible in configuration 3. Below, I will discuss two cases in which this prediction is borne out. First, I will look at an asymmetry between predicative and attributive adjectives in Hungarian. Subsequently, I will discuss a similar case in Swedish.

5.1.1. Hungarian: predicative-attributive asymmetry

Hungarian displays an asymmetry in agreement between predicative and attributive adjectives. Predicative adjectives display number agreement¹⁷ with their subject. This is illustrated in (45). In (45a), the subject *a fiú* ‘the boy’ is singular, while the adjective does not carry any inflection. However, if the subject is replaced by a plural, as in (45b), the form of the adjective changes. In this case, the adjective takes the plural marker *-ok* as inflectional suffix. Attributive adjectives on the other hand never display any agreement with the head noun they modify. The adjective always occurs as a bare stem, no matter whether the head noun is singular as in (46a) or plural as in (46b). The data in (45) and (46) is from Anikó Lipták (personal communication).

- | | | | | | |
|------|----|-------------------------------------------------------------------|------|----|-----------------------------------------------------------------|
| (45) | a. | <i>A fiú nagy.</i>
the boy tall
‘The boy is tall.’ | (46) | a. | <i>a nagy fiú</i> [Hungarian]
the tall boy
‘the tall boy’ |
| | b. | <i>A fiú-k nagy-ok</i>
the boy-PL old-PL
‘the boys are old’ | | b. | <i>a nagy fiú-k</i>
the tall boy-PL
‘the tall boys’ |

¹⁷ As well as case agreement in some instances.

This asymmetry is fully expected under the dominance requirement. Moreover, I argue that the absence of agreement between attributive adjectives and the head noun shows that the dominance requirement makes the correct prediction for configuration 3. Therefore, the absence of agreement on attributive adjectives in Hungarian gives empirical support to the dominance requirement. I will now discuss this in detail.

Consider first the agreeing predicative adjectives. I assume that the subjects of predicative adjectives enter the syntactic derivation as specifiers of the predicative AP.¹⁸ This is illustrated in (47) for (45b).

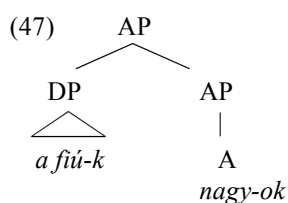

The structure in (47) is an instantiation of configuration 2. The Goal, the subject, is in the specifier of the Probe, the adjective. As I argued in section 4 above, both the c-command requirement and the dominance requirement predict that Agree is possible in this configuration. The reason for this is that the subject is both dominated and c-command by (projections of) the adjectival Probe. These predictions are borne out, as can be seen by the agreement on predicatively used adjectives. My previous conclusion that both the c-command requirement and the dominance requirement make the correct prediction for configuration 2 thus receives again confirmation.¹⁹

As far as attributive adjectives are concerned, I follow Svenonius (1994) (among others) and assume that they are adjuncts to NP.^{20,21} Under this view, the DP in (46a) has the structure in (48).

¹⁸ Whether the subject is internally merged in the specifier of TP later on in the derivation or not is irrelevant for the present discussion.

¹⁹ If A takes a complement, any DPs contained in that complement should not be able to function as a Probe in order for this analysis to hold. This might be due either to adjectival complements being phases or to DPs in the complement being deactivated as a result of case assignment.

²⁰ In chapter 2, I proposed that Germanic adjectives are adjuncts to DP. However, unlike for their Germanic counterparts, I am not aware of any indications that adjectives are adjoined to DP in Hungarian. I will therefore assume for this section that they are NP-adjuncts.

²¹ The same analysis would also hold under the view that adjectives are specifiers in the nominal domain (Cinque (1994), among others). However, the same analysis would not go through if adjectives are heads in the nominal projection line, as claimed by Abney (1987).

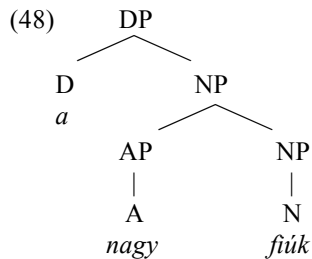

The structure in (48) is an instantiation of configuration 3. The Probe, the attributive adjective, is an adjunct, while the Goal, the head noun, is contained in the sister of the Probe. As I showed above, the c-command requirement predicts that Agree is possible, because the Probe A(P) c-commands the Goal N(P). The dominance requirement however predicts that Agree is impossible, because A(P) does not dominate N(P). Given the absence of agreement on attributive adjectives, see (46) above, the prediction made by the dominance requirement is borne out, while that of the c-command requirement is not.

The dominance requirement thus correctly predicts the Hungarian predicative-attributive asymmetry with respect to adjectival agreement. The c-command requirement on the other hand does not predict it. In this way, Hungarian adjectival agreement constitutes an empirical argument for choosing the dominance requirement over the c-command requirement.

5.1.2. The Swedish predicative-attributive asymmetry

Hungarian is not the only language that displays an asymmetry with respect to agreement between predicative and attributive adjectives. Swedish adjectives display a similar asymmetry. Attributive adjectives in definite DPs²² do not display any agreement in Swedish. They always take an ending that is invariant with respect to the gender and number specification with the head noun. As discussed in the previous chapters, this ending is referred to as the weak adjectival inflection. This is illustrated in (49), in which the invariant ending on the adjective is *-a*, indicated in boldface.²³

- (49) a. *den* *ung-**a*** *flicka-n* NON-NEUTER, SG, DEF
 the.NONNEUTER young-WEAK girl-DEF
 ‘the young girl’
- b. *det* *stor-**a*** *hus-et* NEUTER, SG, DEF
 the.NEUTER big-WEAK house-DEF
 ‘the big house’

²² Attributive adjectives in indefinite DPs behave differently. I will come back to these in section 5.2.1 below.

²³ For some adjectives, the invariant ending is *-e*, instead of *-a*.

- c. *de stor-a hus-en* NEUTER, PL, DEF
 the.PL big-WEAK house-DEF.PL
 ‘the big houses’
- d. *de ung-a flick-or-na* NON-NEUTER, PL, DEF
 the.PL young-WEAK girl-PL-DEF
 ‘the young girls’

However, Swedish predicative adjectives agree with their subject in gender and number. This is illustrated in (50), in which the inflectional ending of the adjective is again indicated by boldface.

- (50) a. *flicka-n* *är ung.* NON-NEUTER SG
 Girl-DEF.NONNEUTER is young
 ‘the girl is young’
- b. *hus-et* *är stor-t* NEUTER, SG
 house-DEF.NEUTER is big-NEUTER
 ‘the house is big’
- c. *flick-or-na* *är ung-a.* NON-NEUTER, PL
 girl-PL-DEF.NON-NEUTER is young-PL
 ‘the girls are young’
- d. *hus-en* *är stor-a* NEUTER, PL
 house-DEF.PL.NEUTER are big-PL
 ‘the houses are big’

This predicative-attributive asymmetry is similar to the Hungarian one in the sense that in both languages attributive adjectives do not display agreement, while predicative adjectives do. As I showed above for Hungarian, this pattern is expected under the dominance requirement, but not under the c-command requirement. Hence, Swedish seems to be another language that provides empirical support for preferring the dominance requirement to the c-command requirement.

5.1.3. Intermediate conclusion

Above, I showed that the dominance requirement correctly predicts the predicative-attributive asymmetries in adjectival agreement in Swedish and Hungarian, while the c-command requirement does not. These asymmetries thus seem to indicate that the dominance condition is more successful than the c-command requirement in accurately predicting the data. However, this is only apparent. There are also patterns of adjectival agreement that seem to support the c-command requirement and that seem to disfavor the dominance requirement. I will now examine these patterns.

5.2. Arguments in favor of c-command

Below, I will discuss two cases in which the agreement is the same on both attributive and predicative adjectives. The first case is a pattern of adjectival agreement in Swedish that differs from the one discussed above. In Swedish, attributive adjectives in indefinite DPs, unlike their counterparts in definite DPs, display the same agreement as predicative adjectives. The second case is adjectival agreement in the Romance languages. Adjectives in these languages always display the same agreement on attributive and predicative adjectives, regardless of the definiteness of the DP the attributive adjectives occur in. Above, I argued that the dominance requirement predicts an asymmetry between attributive and predicative adjectives as far as agreement is concerned, while the c-command requirement does not. Therefore, the two cases discussed below will constitute an empirical argument in favor of the c-command requirement and against the dominance requirement.

5.2.1. The Swedish predicative-attributive symmetry

Above, I showed that there was an asymmetry between attributive adjectives in definite DPs and predicative adjectives. The attributive ones do not display agreement, while the predicative ones do. However, there is more to adjectival agreement in Swedish than this. Attributive adjectives in indefinite DPs behave differently from their counterparts in definite DPs. Unlike those in definite DPs, they take the same agreement markers as predicative adjectives. This is illustrated in (51) - (52). The endings on the adjective in the indefinite DPs in (51), also referred to as strong inflection (see the previous chapter), are identical to those on the predicatively used adjectives in (50), repeated here in (52).

- | | | | | | |
|------|----|-------------------------------------------------------------------|--------------------------------|-----------------------------|-----------------------|
| (51) | a. | <i>en</i>
a.NONNEUTER
'a young girl' | <i>ung</i>
young | <i>flicka</i>
girl | NON-NEUTER, SG, INDEF |
| | b. | <i>ett</i>
a.NEUTER
'a big house' | <i>stor-t</i>
big-NEUTER.SG | <i>hus</i>
house | NEUTER, SG, INDEF |
| | c. | <i>stor-a</i> <i>hus</i>
big-PL house
'big houses' | | | NEUTER, PL, INDEF |
| | d. | <i>ung-a</i> <i>flick-or</i>
young-PL girl-PL
'young girls' | | | NON-NEUTER, PL, INDEF |
| (52) | a. | <i>flicka-n</i>
Girl-DEF.NONNEUTER
'the girl is young' | <i>är</i>
is | <i>ung.</i>
young | NON-NEUTER SG |
| | b. | <i>hus-et</i>
house-DEF.NEUTER
'the house is big' | <i>är</i>
is | <i>stor-t</i>
big-NEUTER | NEUTER, SG |

- c. *flicka-or-na* *är* *ung-a*. NON-NEUTER, PL
 girl-PL-DEF.NON-NEUTER is young-PL
 ‘the girls are young’
- d. *hus-en* *är* *stor-a* NEUTER, PL
 house-DEF.PL.NEUTER are big-PL
 ‘the houses are big’

Under the dominance requirement, this symmetry between predicative and attributive adjectives is unexpected. As I argued above in section 5.1, the dominance requirement predicts that there is an agreement asymmetry between attributive and predicative adjectives. It predicts that agreement between an attributive adjective and the head noun should be impossible, and that agreement between a predicative adjective and its subject should be possible. The fact that the adjectives in (51) take the same agreement markers as those in (52) shows that this prediction is not borne out in this particular case. Therefore, the data in (51) and (52) constitute an argument against the dominance requirement. However, the facts in (51)–(52) are fully expected under the c-command requirement. As pointed out in section 5.1, the adjectival Probe c-commands the nominal Goal in the case of both attributive adjectives and predicative adjectives (see the discussions of (47) and (48) above). Hence, the c-command requirement is met both with predicative and attributive adjectives and hence Agree is predicted to be possible in both cases. The symmetry in agreement between predicative and attributive adjectives in indefinite DPs in Swedish thus seems to constitute an empirical argument in favor of the c-command requirement.

This conclusion gives rise to a rather paradoxical situation. In Swedish, there are thus indications that the dominance requirement should be preferred to the c-command requirement, but also that the c-command requirement should be preferred to the dominance requirement. Within the same language, adjectival agreement facts thus give contradictory clues about the structural condition on Agree.

5.2.2. Romance: French

Swedish is not the only language in which adjectival agreement seems to suggest that the c-command requirement is the most empirically accurate formulation of the structural condition on Agree. The Romance languages also suggest this. These languages display no asymmetry in agreement between the predicative and the attributive use of adjectives. This is illustrated for French in (53) and (54). The attributive adjectives in (53) inflect exactly in the same way as their predicative counterparts in (54).

- (53) a. *le* *livre* *intéressant*
 the.MASC.SG book interesting.MASC
 ‘the interesting book’
- b. *l’* *histoire* *intéressant-e*
 the story interesting.FEM.SG

- (54) a. *le livre est intéressant*
 the.MASC.SG book is interesting.MASC
 b. *l'histoire est intéressante*
 the story is interesting-FEM.SG

As I mentioned above, the c-command requirement predicts this symmetry in agreement between the attributive and predicative use of the adjective. However, the dominance requirement does not. Hence, the fact that attributive and predicative adjectives receive the same inflection in the Romance languages constitutes an additional empirical argument in favor of the c-command requirement.

5.3. A deadlock

The investigation of adjectival agreement of this section has produced contradictory results. On the one hand, I argued that the agreement asymmetries between predicative and attributive adjectives in Hungarian and Swedish indicate that the dominance requirement must be preferred to the c-command requirement. On the other hand, I showed that the symmetries in agreement between predicative and attributive adjectives in the Romance languages and Swedish indicate that the c-command requirement must be favored over the dominance requirement. These results are summarized in the table in (55)

(55) PREDICTIONS MADE BY THE C-COMMAND AND THE DOMINANCE REQUIREMENT

	HUNGARIAN	SWEDISH ASYMMETRY	SWEDISH SYMMETRY	ROMANCE
PREDICTION BPS-C- COMMAND	*	*	✓	✓
PREDICTION DOMINANCE	✓	✓	*	*

The adjectival agreement data discussed in this section thus do not provide conclusive evidence in favor of either the c-command requirement or the dominance requirement. It therefore seems that the search for the most accurate formulation of the structural condition on Agree are in a deadlock. Both the c-command requirement and the dominance requirement seem to be as successful, or as unsuccessful, in predicting whether Agree can take place or not.

6. Conclusion

In this chapter, I tried to determine the best formulation of the structural condition on Agree. I discussed three different candidates: the complement requirement, the c-command requirement, and the dominance requirement. Of these three candidates, I discarded the complement requirement because it cannot deal with person agreement in Georgian. The choice between the other two candidates turned out to be a difficult one. In order to decide between the c-command requirement and the dominance requirement, I examined how successful they each are in predicting the patterns of adjectival agreement in some European Languages. However, this investigation returned inconclusive results. On the one hand, the c-command requirement correctly predicts that predicative and attributive adjectives show the same agreement in Romance. For Swedish, it makes the correct prediction for the similarity of agreement between predicative adjectives and attributive ones in indefinite DPs. On the other hand, the dominance requirement correctly predicts the asymmetry in agreement between predicative and attributive adjectives in Hungarian and the agreement asymmetry in Swedish between attributive adjectives in indefinite DPs and predicative adjectives. Hence, the c-command requirement and the dominance requirement seem to be as successful or as unsuccessful in predicting whether adjectival agreement can occur.

Despite the empirical problems it faces, I will adopt the dominance requirement over the c-command requirement. The reason for this is that it has an additional advantage over the c-command requirement; it is simpler. On the theoretical simplicity scale in (34) above, the dominance requirement outranks the c-command requirement. This is because the dominance requirement is stated in terms of the primitive syntactic relation of dominance. The c-command requirement on the other hand is formulated in terms of the non-primitive relation c-command.

In the following two chapters, I will show that the patterns of agreement on attributive adjectives in Germanic can be explained under an analysis that assumes the dominance requirement to be the structural condition on Agree. Agreement on attributive adjectives in Germanic is of interest, because of the difference between adjectival agreement in definite DPs and indefinite DPs. The Swedish facts I discussed above are an example of this. Under the dominance requirement, agreement on attributive adjectives cannot be licensed via a direct Agree-relation between the adjective and the noun. In chapter 4, I will argue that as a consequence of this, agreement on attributive adjectives is licensed indirectly. This will constitute the key for my analysis of the difference in adjectival agreement in Germanic definite and indefinite DPs. In chapter 6, I will then come back to the dominance requirement and show that its empirical problems turn out to be only apparent, in light of the proposals that will be introduced in chapter 4. This will show that the dominance requirement is not only the simplest candidate for the structural condition on Agree, but it is also empirically the most adequate one.

Chapter 4

Strong and weak adjectival inflection in Germanic

1. Introduction

In Swedish as in most other Germanic languages, attributive adjectives in definite DPs inflect differently from those in indefinite DPs. In definite DPs, the ending of the adjective is invariant *-a* or *-e* (depending on the shape of the adjectival stem), irrespective of the gender and number of the head noun. This is illustrated in (3).

- | | | | | | |
|-----|----|-------------------------------------------------|----------------------------|---------------------------------------|------------------|
| (1) | a. | <i>den</i>
the.NONNEUTER
'the young girl' | <i>ung-a</i>
young-WEAK | <i>flicka-n</i>
girl-DEF.NONNEUTER | NON-NTR, SG, DEF |
| | b. | <i>det</i>
the.NEUTER
'the big house' | <i>stor-a</i>
big-WEAK | <i>hus-et</i>
house-DEF.NEUTER | NEUTER, SG, DEF |
| | c. | <i>de</i>
the.PL
'the big houses' | <i>stor-a</i>
big-WEAK | <i>hus-en</i>
house-DEF.PL | NEUTER, PL, DEF |
| | d. | <i>de</i>
the.PL
'the young girls' | <i>ung-a</i>
young-WEAK | <i>flick-or-na</i>
girl-PL-DEF | NON-NTR, PL, DEF |

In indefinite DPs, however, there are three different endings for adjectives. Which of these endings is chosen depends on the gender and number features of the noun that is modified by the adjective. This is the case both in DPs introduced by the indefinite article (2a-b) and in DPs without an article (2c-d)/(3). Adjectives that modify a singular non-neuter noun take a zero ending, as in (2a)/(3a). Those that modify a singular neuter noun take *-t* as their ending, as in (2b)/(3b). Finally, adjectives modifying plural nouns have an *-a* ending, as in (2c-d).

- | | | | | | |
|-----|----|---------------------------------------------|---------------------------------|----------------------------|--------------------|
| (2) | a. | <i>en</i>
a.NON-NEUTER
'a young girl' | <i>ung-Ø</i>
young-NONNEUTER | <i>flicka</i>
girl | NON-NTR, SG, INDEF |
| | b. | <i>ett</i>
a.NEUTER
'a big house' | <i>stor-t</i>
big-NEUTER | <i>hus</i>
house | NEUTER, SG, INDEF |
| | c. | <i>två</i>
two
'two young girls' | <i>ung-a</i>
young-PL | <i>flick-or</i>
girl-PL | NON-NTR, PL, INDEF |

- d. *två* *stor-a* *hus- Ø* NEUTER, PL, INDEF
 two big-PL house-PL
 ‘two big houses’
- (3) a. *god-Ø* *matt* NON-NTR, SG, INDEF
 good-NONNEUTER food
 ‘good food’
- b. *vacker-t* *väder* NEUTER, SG, INDEF
 beautiful-NEUTER weather
 ‘beautiful weather’

The adjectives in indefinite DPs thus agree in gender and number with the noun they modify, while their counterparts in definite DPs do not. This inflectional paradigm for adjectives in Swedish is summarized in the table in (4).

(4) ADJECTIVAL INFLECTION IN SWEDISH DEFINITE AN INDEFINITE DPS

	SG, NON-NEUTER	SG, NEUTER	PL
Definite DPs	-a/-e ¹	-a/-e	-a/-e
Indefinite DPs	Ø	-t	-a/-e

In traditional grammars, the inflection on adjectives in indefinite DPs is generally called ‘strong’, while its counterpart in definite DPs receives the label ‘weak’. This is so because the inflection on adjectives in indefinite DPs marks more gender and number distinctions than its counterpart in definite DPs. In Swedish, for instance, the strong adjectival inflection marks a gender distinction, neuter (-*t*) vs. non-neuter (-Ø) and a number distinction, singular (-*t*/-Ø) vs. plural (-*a*). The weak adjectival inflection, on the other hand, does not mark any such distinction. This strong-weak distinction on adjectival inflection is not just some idiosyncratic property of Swedish. It is found throughout the Germanic languages. Of the major Germanic languages, only English and Afrikaans do not display this distinction.²

This strong-weak distinction on adjectival inflection played an important role in the two previous chapters. In chapter 2, I used it to motivate my proposal that the derivation of Swedish definite DPs with adjectives involves internal merge of D. In this way, the strong-weak distinction played an essential role in my analysis of double definiteness. In chapter 3, the strong-weak distinction was used in the discussion of the different candidates for the correct characterization of the structural condition on Agree. Weak adjectival inflection favored the dominance requirement, while strong adjectival inflection supported the c-command requirement. Despite its important role in the previous chapters, a full account of the strong-weak distinction has however not yet been presented. In this chapter, I propose such an account. In particular, I address the following three questions, (5).

¹ The choice between -*a* and -*e* is lexically determined by the adjective: some adjectives take -*a*, others -*e* (see Holmes & Hincliffe 1994).

² West-Flemish also does not display a strong-weak distinction on attributive adjectives. I will come back to West-Flemish in chapter 6. For Afrikaans, see Donaldson (1993:163).

- (5) **QUESTIONS**
- I. LICENSING:
How is the strong and weak adjectival inflection licensed?
 - II. LOSS OF DISTINCTIONS:
Why does the weak adjectival inflection express less (or even no) case, number, gender distinctions than the strong adjectival inflection?
 - III. DISTRIBUTION
How can the distribution of strong and weak adjectival inflection be accounted for?

This chapter is organized as follows. I will first introduce the theory of Agree that I will be using for my analysis of strong and weak adjectival inflection. In particular, I will propose some refinements to the theory of Agree in addition to my conclusion of the previous chapter that the structural condition on Agree should be formulated in terms of dominance. These refinements will concern the way in which Agree relations should be conceived of, the manner in which they are dealt with at the interfaces and the structure of morphosyntactic features that are involved in Agree relations. I will then formulate my proposal for strong and weak adjectival inflection. Next, I will show in detail how this proposal accounts for the strong-weak distinction in Swedish. I will then argue that the analysis also accounts for the patterns of inflection on attributive adjectives in Norwegian, Danish, and Dutch.

2. Features, Agree and the interfaces

In chapter 2, I argued that, under the null hypothesis, the syntactic mechanisms that license adjectival agreement are the same as those that are responsible for the licensing of other types of agreement, like for instance subject-verb agreement. The standard assumption in present day minimalism is that agreement is syntactically licensed by means of the relation Agree (Chomsky 2000, 2001). I therefore argued that adjectival agreement is also syntactically licensed by Agree. In this chapter, I will continue to adopt this null hypothesis and propose an analysis of the strong-weak distinction in terms of Agree. However, in order to be able to do so, I first have to specify some of the details of how Agree syntactically licenses agreement. This will be done in this section.

I will first introduce the structure that I assume for morphosyntactic features. I will then specify the assumptions concerning the exact mechanism of Agree that I adopt. These assumptions combined with the adopted feature structure will have particular consequences for the kind of Agree relations that can be established. After examining these consequences, I will investigate how the interfaces deal with the outcomes of Agree.

The goal of this section is to introduce a theoretical framework for the syntactic licensing of agreement that makes fine-grained predictions about the agreement possibilities in a given syntactic configuration. It will permit me to pro-

perly calculate, and therefore also to evaluate, the results of the proposals about adjectival agreement that I put forward in the following sections.

2.1. The syntactic representation of features

Agreement is a term for the observation that a syntactic object covaries with the morphosyntactic features from another syntactic object. For instance, in the case of Swedish (strong) adjectival agreement, the adjective adopts the number and gender features of the noun it modifies. In (2b), repeated here as (6), the adjective *stor-*‘big’ adopts the neuter gender feature of the noun *hus* ‘house’.

- (6)
- | | | | |
|---------------|---------------|------------|-------------------|
| <i>ett</i> | <i>stor-t</i> | <i>hus</i> | NEUTER, SG, INDEF |
| a.NEUTER | big-NEUTER | house | |
| ‘a big house’ | | | |

Given that morphosyntactic features play a central role in agreement, any theory of agreement must assume a particular view about how morphosyntactic features are represented in the grammar. I will first discuss Chomsky’s (2001) proposal regarding this matter. Chomsky’s proposal constitutes the standard view in current minimalism. However, I will show that it suffers from some serious drawbacks, among which is a serious learnability problem. I will then investigate whether an alternative proposal that assumes that one of the interpretations of a feature is obligatory mapped onto an attribute without a value constitutes a viable alternative to Chomsky’s proposal. However, I will argue that this alternative also faces a learnability problem, albeit a different one from the one pointed out for Chomsky (2001). In order to avoid the problems of both these two proposals, I will then propose an alternative view of how morphosyntactic features should be represented. This alternative view will play a major role in the account of German weak adjectival inflection presented in chapter 5.

2.1.1. Chomsky’s (2001) attribute-value system

In the framework of Chomsky (2001) (see also Pesetsky & Torrego 2004, a.o.), morphosyntactic features are represented in syntax through means of an attribute-value structure like the one in (7).

- (7) [x:y]

In (7), *x* represents the attribute. The attribute indicates the type of the feature involved, (e.g. number, gender, case, person, etc.). *y* in (7) stands for the value of the feature involved, (e.g. singular, plural, neuter, 2nd person, etc.). Some examples of possible attribute-value pairs in this notation are [#: pl] for plural number, [gen: neut] for neuter gender and [case: acc] for accusative case.

There is more to morphosyntactic features than their syntactic representation. They can also have a semantic interpretation and a morphological realization.³ For instance, the plural number feature on nouns is semantically interpreted as ‘plural’ and morphologically realized in English as *-s*, (cf. *book-s*). In order to obtain the semantic interpretation of a feature in Chomsky’s system, the attribute-value pairs are submitted to the CI-component of the grammar. In this component, the attribute-value pair is mapped onto an interpretation. A precondition for this mapping is that the attribute-value pair is associated with a syntactic category on which it can be interpreted. If it is not on such a category, the attribute-value pair is deleted at the CI-interface. For instance, number is interpretable on N, but not on T. Therefore, the attribute-value pair [$\#$:pl] is mapped onto the interpretation ‘plural’, if it is on N, as in (8a), but it is however deleted when it is on T, as in (8b).

- (8) CI-INTERPRETATION
 a. N: [$\#$: pl] \rightarrow ‘plural’
 b. T: [$\#$: pl] \rightarrow \emptyset

In order to obtain the morphological realization of a morphosyntactic feature, all attribute-value pairs, no matter whether they are interpretable in the CI-component or not, are submitted to the SM component of the grammar.⁴ In this component, the attribute-value pairs are mapped onto inflectional morphemes. This is in line with the view that vocabulary items are inserted after narrow syntax, as in the distributed morphology model of the grammar (Halle & Marantz (1993) that I adopted in chapter 2.⁵ The attribute-value pair in (8a) is for instance mapped in English onto the plural suffix *-s* (cf. *book-s*), as in (9).

- (9) SM-INTERPRETATION
 N: [$\#$: pl] \rightarrow *-s*

Chomsky’s proposal that the syntactic representation of morphosyntactic features consists of an attribute-value structure faces two major problems. The first problem concerns the notion of attribute. The second problem has to do with the acquisition of an attribute-value structure in case this structure is morphologically unrealized.

In the framework of Chomsky (2001), the role of the attribute in narrow syntax is to trigger Agree. Agree is established in order to provide a value for a feature that consists of an attribute without a value. Despite this syntactic function,

³ Note that this is far from obligatory for every instance of a feature. For instance, a plural number feature on T does not receive a semantic interpretation, while singular number is not morphologically realized on nouns in English.

⁴ Otherwise uninterpretable features could never be morphologically realized, contrary to fact. Number is for instance uninterpretable on T, but is realized on T as number inflection.

⁵ Chomsky (2001:10-11) limits the postsyntactic insertion of vocabulary items to inflectional elements. Contrary to the standard view in distributed morphology, he assumes that other vocabulary items are inserted prior to narrow syntax. As morphosyntactic features are realized by inflectional elements, this difference between Chomsky (2001) and distributed morphology is not of interest for the present discussion.

the attribute seems to be unmotivated in the CI- and SM-components of the grammar.

In the SM-components of the grammar, i.e. morphology and phonology, attributes are not morphologically realized. I am not aware of any language in which attributes are spelled out independently from values through means of specifically dedicated morphemes. Instead, languages consistently spell out values. In other words, languages tend to have morphemes for values as plural, neuter, and accusative, but not for attributes as number, gender and case. It thus seems that attributes are not interpreted at the SM-levels of the grammar.

On the CI-side of the grammar, a similar picture emerges: values can be interpreted, while attributes seem to be redundant for interpretation. Values are interpreted as long as they are on the right syntactic node. If a nominal syntactic node has a number attribute with a plural value, the CI-system interprets the noun with which it is associated as being plural, as in as in (8a). However, attributes do not seem to be interpreted in the CI-component of the grammar. First, note that no attribute in the framework of Chomsky (2001) will ever be interpreted without a value. The reason for this is that Chomsky takes attributes without a value, or unvalued features, to be uninterpretable at the interfaces. Under this view, attributes will only reach the CI-component of the grammar if they are associated with a value. In association with a value, the attribute indicates the type of interpretation a value receives, e.g. a number attribute indicates that ‘singular’ and ‘plural’ are interpretations that are part of a collection of interpretations that can be labelled as ‘number’. However, it is doubtful whether the CI-system needs to be explicitly fed with this kind of information. The CI-system can easily infer this information on the basis of a value alone, because a value is always associated with only one feature type. For instance, singular is always a value of number, never of gender. The information conveyed by the attribute therefore seems to be redundant in the CI-components of the grammar.⁶

Given that attributes are not needed in the CI-component and that they are never mapped onto morphemes in the SM-component, the attributes in Chomsky’s proposal are only motivated by their syntactic task of triggering Agree (see above). In this sense, attributes are only syntactically relevant. This is theoretically suspect. In principle, the number of pure syntactic theoretical notions, i.e. notions that do not play a role in other components of the grammar, should be kept as low as possible.

In addition to the notion of attribute being unmotivated outside narrow syntax, Chomsky’s attribute-value feature structure faces another problem. This problem concerns the learnability of the attribute-value structure in case it is not morphologically realized. Not every attribute-value structure is mapped onto a morpheme. Consider for instance the morphological realization of number in English. Although plural number in English is mostly spelled out on the noun through means of the *-s* suffix, as in *the book-s* or *the house-s*, singular number is

⁶ David Pesetsky (personal communication) notes that in a binary feature system in which the values are + or –, e.g. [+pl] for plural and [-plural] for singular, attributes are necessary for interpretation in the CI-components of the grammar.

not morphologically realized on the noun (cf. *the book, the house*).⁷ In Chomsky's attributive-value system, the existence of a specific value is independent of its morphological realization. Although singular and plural in English thus differ with respect to morphological realization, singular and plural correspond each to a value of the number attribute (#). I indicated this in (10), in which *sg* stands for the singular value and *pl* for the plural value.

- (10) a. [#:sg] 'singular number'
 b. [#:pl] 'plural number'

In the case of plural number, a L1 learner who needs to acquire the syntactic representation of English number has positive morphological evidence for postulating the *pl*-value in the form of the plural *-s* suffix. However, he or she has no positive morphological evidence for postulating the *sg*-value in case of singular number. This is problematic from the point of view of language acquisition. In the absence of positive morphological evidence for a *sg*-value, the question arises how that value can ever be acquired by a L1 learner. Hence, the standard minimalist feature structure faces a learnability problem with respect to morphologically unrealized values.

One might object that this learnability problem is only apparent and that the language learner can simply infer the existence of the morphologically unrealized values on the basis of the semantic interpretation of the morphologically realized ones. This is however not the case.

Of course, the absence of morphological marking on an element can be meaningful in the light of a contrast with morphologically marked elements. For instance, count nouns without morphological number marking are undoubtedly interpreted in English as being singular. This is so because they contrast with nouns that are morphologically marked for plural. However, the fact that morphologically unmarked forms receive a particular semantic interpretation with respect to a feature does not necessarily imply that they carry a value in syntax that corresponds to that interpretation. The only thing that is needed in syntax in order to ensure the interpretation of an element without morphological marking for a specific feature is that the representation for this feature is different from that of an element that is morphologically marked for it.

This can be achieved without postulating a value for the morphologically unmarked element. The morphologically unmarked element could just be underspecified in syntax for the relevant feature (cf. Rooryck 1994, Harley & Ritter 2002 and Cowper 2005 among others). Put differently, it could carry a feature structure without a value, i.e. a structure that only consists of an attribute. In that case, the morphological unmarked element differs from the morphologically marked element with respect to the level of specification of the syntactic representation of the relevant feature. The morphologically marked element carries a fully specified

⁷ David Pesetsky (personal communication) points out to me that there are words in English in which singular seems to be morphologically encoded in the sense that there is a vocalic alternation between singular and plural, as can be seen in the following pairs: *alumnus-alumni, cactus-cacti, thesis-theses, mouse-mice, goose-geese*.

feature structure consisting of an attribute and a value, e.g. [#:pl] for the English plural. The morphologically unmarked element would only carry the attribute, e.g. [#:] for the English singular.⁸ In the CI-components of the grammar these two different feature specifications are then mapped on two different semantic interpretations. In the case of English number, this mapping would take the form in (11).

(11)	CI-INTERPRETATION FOR ENGLISH NUMBER ON NOUNS		
	feature specification		CI-interpretation
a.	[#:]	→	‘singular’
b.	[#: pl]	→	‘plural’

It is thus not necessary for a child to posit a value for a feature that is not morphologically marked in order to interpret the feature in the CI-component of the grammar. In this way, the postulation of a value in the absence of morphological realization is not only unmotivated from a morphological point of view, i.e. no morphological clue for the existence of the value, but also from a semantic perspective, i.e. the value is not necessary for interpretation. For this reason, the lack of morphological realization of a value constitutes a learnability problem for Chomsky’s feature system.⁹

2.1.2. An alternative: obligatory feature underspecification

The lack of motivation for attributes at the interfaces in combination with the learnability problem suggests that Chomsky’s (2001) feature structure is inadequate. The question therefore arises whether it can be replaced by a more satisfactory alternative. Above I mentioned the possibility that attributes without values could be interpreted at the CI-interface, i.e. that an attribute without a value is mapped onto one of the interpretations of a feature. For instance, a number attribute without a value, i.e. an underspecified number feature, could in principle be mapped onto the meaning ‘singular’. Given this possibility, an obvious alternative to Chomsky’s (2001) feature system would be a feature system in which an attribute without a value is obligatory mapped onto one of the interpretations of that feature. Put differently, in such a system an underspecified feature, i.e. an attribute without a value, is in principle interpretable at the CI-interface.

⁸ Another way of looking at this is that ‘plural’ is a privative subfeature of the number feature. The number feature without this subfeature being interpreted as singular.

⁹ In order to circumvent the learnability problem, one might propose that feature values are part of UG, i.e. the innate knowledge of natural language a child is endowed with. In that case, feature values do not need to be acquired, because they are just given. Hence, there would be no learnability problem, concerning values that lack morphological realization. However, it is doubtful whether such a move would be justifiable. Something should only be considered part of UG if extensive research shows that it cannot be acquired through means of positive evidence. It is however highly unlikely this is the case for feature values. The language input a child receives contains quite a lot of positive evidence for feature values in the form of inflectional morphology.

Harley & Ritter (2002a,b) propose a system of feature representation in which this obligatory underspecification plays a major role (see Harley & Ritter 2002a:486). However, I will not discuss their proposal in detail here, since it also involves other aspects that do not concern us here, like a universal feature geometry with nested attributes. Instead, I will abstract from the actual Harley & Ritter proposal and examine here how a morphosyntactic feature representation with obligatory feature underspecification would look like using the attribute-value notation also used in Chomsky (2001).

As mentioned above, the essence of the obligatory underspecification proposal of morphosyntactic feature representation is that one of the interpretations of a feature in the semantic component corresponds to an attribute without a value in syntax, while the other interpretations correspond to attribute-value pairs in syntax.¹⁰ Under this proposal, attributes are thus interpretable at the CI-interface. This is crucially different from Chomsky (2001) in which attributes without a value are always uninterpretable at the CI-interface, since all interpretations of a feature correspond to attribute-value pairs. In order to illustrate this, the table in (12) contrasts Chomsky's syntactic representation of the number feature in English in (10) above with an obligatory underspecification representation for this feature in (11) above.

- (12) NUMBER IN ENGLISH: CHOMSKY (2001) AND OBLIGATORY UNDERSPECIFICATION

CI-interpretation	Syntactic representation	
	Chomsky (2001)	obligatory underspecification
'singular'	[#: sg]	[#:]
'plural'	[#: pl]	[#: pl]

This obligatory underspecification proposal does not suffer from the same drawbacks as Chomsky's proposal.

The first problem that Chomsky's proposal faced was that attributes did not play any role outside narrow syntax and were therefore theoretically dubious. This is not the case in the obligatory underspecification proposal. Under this proposal, each attribute without a value, i.e. each feature node without a dependent, is interpretable at the CI-interface, on the condition that it is associated with the right syntactic category. Attributes are in this way also motivated outside of narrow syntax.

The second problem for Chomsky (2001) was the learnability problem concerning morphologically unrealized values. In Chomsky (2001), each interpretation of a feature corresponds to a different value in the syntactic representation of the feature in question. However, sometimes an interpretation lacks morphological realization. In that case, there is no positive morphological evidence for postulating a value in the syntactic representation. The obligatory underspecification proposal does not have this drawback. In this system, no value needs to be

¹⁰ Of course, this only hold if the attribute without a value occurs on a syntactic element on which it is semantically interpretable.

- (16) ABSENCE OF MORPHOLOGICAL REALIZATION:
GENDER ON DUTCH DEFINITE ARTICLES

Interpretation	Morpheme
'neuter'	<i>het</i>
'non-neuter'	<i>de</i>
'neuter'/'non-neuter'	<i>de</i>

In the case of gender in Dutch, the L1-learner in Chomsky's system must postulate a non-neuter value, even though there are no morphological clues to back this up. This is not the case in a feature system based upon obligatory underspecification. In such a system, the morphologically unrealized 'non-neuter' interpretation can simply be mapped onto the attribute [Gen:] of the syntactic representation of the gender feature, as in (17a). The 'neuter' interpretation, for which there is evidence for a value in the form of *het*-form of the definite article, is, on the other hand, mapped onto an attribute-value pair, as in (17b). In this way, no value needs to be postulated for the morphologically unrealized non-neuter interpretation.

- (17) a. 'non-neuter' → [Gen:]
b. 'neuter' → [Gen: neuter]

This mapping of the morphologically unrealized interpretation onto the attribute is a direct consequence of the way in which morphological realization works. In the distributed morphology (Halle & Marantz 1993) model of grammar that I adopt in this thesis (see chapter 2), morphological realization, i.e. Vocabulary Insertion, is subject to the subset principle (Halle 1997).¹¹ The subset principle stipulates that only the most specific morpheme compatible with a particular morphosyntactic feature bundle can spell out that bundle. A given morpheme is the most specific morpheme for a given morphosyntactic feature bundle if two conditions are met. First, the feature specification of the morpheme must be a subset of the feature specification of the morphosyntactic feature bundle. Put differently, the morpheme cannot carry any feature specifications that are not also part of the morphosyntactic feature bundle it spells out. Second, there must be no other morpheme that meets the first condition and is more specific, i.e. is specified for more features.

Under the subset principle, a feature of which one of the interpretations is morphologically unrealized can only be successfully acquired if the L1 learner maps the morphologically unrealized feature interpretation onto the underspecified syntactic feature representation. Put differently, the subset principle forces the L1 learner to map the morphologically unrealized interpretation onto the attribute in the syntactic representation. In order to appreciate this, consider the way in which acquisition fails in case the L1 learner does not map the morphologically unrealized feature interpretation onto the attribute, but onto an attribute-value structure instead. I will illustrate this again by the example of gender in Dutch and its realization on the definite article, see (16) repeated here in (18).

¹¹ Halle's (1997) subset principle is a borrowing from Anderson (1992) who is using Kiparsky's (1973) elsewhere condition to structure the lexicon. Thanks to David Pesetsky for pointing this out to me.

- (18) ABSENCE OF MORPHOLOGICAL REALIZATION:
GENDER ON DUTCH DEFINITE ARTICLES

Interpretation	Morpheme
'neuter'	<i>het</i>
'non-neuter'	<i>de</i>
'neuter'/'non-neuter'	<i>de</i>

Mapping the morphologically unrealized feature interpretation onto a fully specified syntactic representation of that feature would mean in this case that 'non-neuter' gets mapped onto a gender attribute with a non-neuter value, i.e. [Gen: nonneut] instead of mapping it onto [Gen:]. Since in a feature structure that is based upon obligatory underspecification one interpretation is always mapped onto the attribute, the morphologically realized 'neuter' interpretation must then necessarily be mapped onto [Gen:]. The *het*-form of the definite article only occurs with neuter nouns. It therefore must be equally specified as the 'neuter' interpretation. In this case, this means that the *het*-form must be specified as [Gen:]. The *de*-form of the definite article is not specified for the gender feature at all, given that it also occurs in a context which is neutral with respect to gender, i.e. in the plural.

The subset principle demands that the most specified morpheme is inserted to spell out the interpretation 'non-neuter'. In this case, this would be the *het*-form of the definite article, because the *het*-form is specified for gender, while the *de*-form is not. Hence, mapping the morphologically realized interpretation 'neuter' onto [Gen:] would result in the *het*-form being used both with neuter and non-neuter nouns. However, the *het*-form is only used in Dutch with neuter nouns (see the table in in (18)). Given the subset principle, the Dutch gender-system would thus not be not correctly acquired in case the morphologically unrealized non-neuter interpretation is mapped onto an attribute-value structure. Put differently, it is impossible under the subset principle to map a morphologically unrealized interpretation onto fully specified syntactic feature representation, i.e. an attribute-value pair.

However, if the L1 learner maps the morphologically unrealized feature interpretation, i.e. 'non-neuter' in the case at hand, onto the underspecified feature structure, the Dutch gender system and its expression on the definite article is acquired without any problem. In that case, 'non-neuter' in (18) is underspecified in syntax as [Gen:] and 'neuter' fully specified as [Gen: neut]. As a consequence, the *het*-form of the definite article is specified as [Gen: neut]. Given that it is thus more specified than 'non-neuter', the *het*-form of the definite article is not a candidate to spell out 'non-neuter', given to the subset principle. As a result, only the *de*-form of the definite article, which is not specified for gender at all, can spell out 'non-neuter'.

In this way, the Dutch gender system in (18) is correctly acquired. This illustrates that, under the subset principle, a morphologically unrealized feature interpretation must be mapped onto an underspecified feature specification in order to achieve a successful acquisition. The subset principle forces in this way the L1 learner to assign the underspecified feature specification to the morphologically unrealized feature interpretation.

Although it does not suffer from the same complications as Chomsky (2001)'s proposal, the obligatory underspecification proposal also faces a problem. This problem concerns the learnability of the interpretation of attributes without a value in case there is a one-to-one mapping of interpretations and morphemes. Under obligatory underspecification, every feature necessarily has one interpretation that is mapped onto the underspecified syntactic representation of that feature, i.e. onto an attribute without a value. Above, I showed that, if one of the interpretations of a particular feature is not morphologically realized, this is the interpretation that gets mapped onto the attribute. This was the result of the subset principle. If all the interpretations of a feature are morphologically realized, it is however impossible for the L1 learner to determine which of the interpretations corresponds to the attribute of that feature in the syntactic representation. In order to appreciate this, consider person marking in Latin. In Latin, first, second, and third person are all realized by a different ending on the verb. This is illustrated in (19) for the singular part of the active present tense paradigm of the verb *monere* 'to warn'.

- (19) a. *mon-e-o* b. *mon-e-s* c. *mon-e-t*
 warn-1P warn-2P warn-3P
 'I warn' 'You warn' 'he/she/it warns'

There is thus a one-to-one mapping in Latin between the different interpretations of the person feature and the verb endings realizing these interpretations. This is schematized in the table in (20).

- (20) FULL MORPHOLOGICAL REALIZATION:
 PERSON IN LATIN

Interpretation	Morpheme
1 st person	-o
2 nd person	-s
3 rd person	-t

Under obligatory underspecification, one of the interpretations of the person feature corresponds in syntax to a person attribute without a value, [Person:], while the other two interpretations correspond to two attribute-value pairs, e.g. [Person: value a] and [Person: value b]. Given the one-to-one mapping between interpretations and morphemes in (20), the L1 learner has however no indication whatsoever which of the three interpretations should be mapped onto the attribute. It could be first person, but it could also be second or third person. This poses a learnability problem. In feature system based on obligatory underspecification, the L1 learner is thus confronted with a learnability problem if all interpretations of a feature are morphologically realized.¹²

¹² In footnote 9, I discussed the possibility that the learnability problem for Chomsky's (2001) feature system could be circumvented by proposing that the elements that caused the problem are just part of UG. Harley & Ritter (2002a,b) propose something similar for the mapping of feature interpretations onto attributes without a value (or in their terms feature nodes without dependents). They specify this mapping in their feature geometry. Considering that they take this geometry to be part of UG, they thus also claim

2.1.3. Morpho-driven feature representation

Above, I showed that the feature systems of Chomsky (2001) as well as a feature system based on obligatory underspecification face learnability problems. In a sense, these problems arise because both proposals are too rigid with respect to the morphological realization of feature interpretations. Chomsky's feature system, in which every feature interpretation is mapped onto an fully specified syntactic representation (i.e. an attribute-value pair), is perfectly adequate in case all feature representations are morphologically realized. It however runs into trouble as soon as one of the feature interpretations is not. Contrary to Chomsky's system, the obligatory underspecification feature system is based on the assumption that every feature has one interpretation that is mapped onto an underspecified syntactic representation. This is perfectly adequate in case one of the feature interpretations is not morphologically realized, but it runs into problems in case all feature interpretations are morphologically realized.

In order to resolve these problems, I present an alternative, more flexible, view on feature structure. I propose that the mapping of feature interpretations onto the syntactic representation of that feature is completely dependent on morphological realization. If one of the interpretations of a particular feature is not morphologically realized, this interpretation is mapped onto an underspecified feature representation, i.e. onto an attribute. If, on the other hand, an interpretation of a particular feature is morphologically realized, this interpretation is mapped onto a fully specified feature representation, i.e. onto an attribute-value pair. I refer to this proposal as *morpho-driven feature representation*, (21).

- (21) MORPHO-DRIVEN FEATURE REPRESENTATION¹³
 If an interpretation of a particular feature is:
- a. **morphologically realized**, the interpretation is mapped onto a fully specified feature representation, i.e. an attribute-value pair.
 - b. **morphologically unrealized**, the interpretation is mapped onto an underspecified feature representation, i.e. onto an attribute.

An important characteristic of the proposal in (21) is that it allows for crosslinguistic variation with respect to the morphosyntactic representation of a particular feature, since morphological realization can vary crosslinguistically. This will play an

that this mapping is part of UG. In that case, there would not be a learning problem for the L1 learner. The L1 learner would then simply not need to determine on the basis of morphological evidence which interpretation is mapped onto the underspecified feature, because this information is already part of its innate knowledge. However, as pointed out in footnote 9, only information that cannot be acquired via positive evidence in the language signal should be part of UG. In that footnote, I however argued that there is abundant positive evidence for acquiring the feature structure available to the L1 learner in the form of morphemes that spell out this mapping. The mapping between feature structure and feature interpretation is therefore most probably not part of UG.

¹³ It might be the case that morpho-driven feature representation is too powerful and that some features have a structure that is more determined by their semantics. Person might be a case at hand, because of indication that 3rd person is really crosslinguistically behaving as the default person, even when it receives morphological realization. I will leave this issue to further research.

important role in my account of why weak adjectival inflection in German signals a number distinction, while Swedish does not. I will come back to this below.

The proposal in (21) is flexible in the sense that it results in some features being structured along the lines of the obligatory underspecification proposal and other features along those of Chomsky's (2001) proposal.

If one of the interpretations of a particular feature is morphologically unrealized, the mapping of feature interpretations onto feature structure is as under the obligatory underspecification proposal. The morphologically unrealized interpretation is mapped onto an attribute without a value, while the morphologically realized interpretations are mapped onto attribute-values pairs. In morpho-driven feature representation, the syntactic representation of number in English is identical to the one under the obligatory underspecification proposal in (12). The morphologically unrealized singular of English is mapped onto the number attribute (#), while the morphologically realized plural is mapped onto an attribute-value pair consisting of the number attribute (#) and a plural value (pl), as in the table in (22).

(22) ABSENCE OF MORPHOLOGICAL REALIZATION: NUMBER IN ENGLISH

Interpretation	Morpheme	Feature Structure
'singular'	–	[#:]
'plural'	-s	[#: pl]

If, on the other hand, all the interpretations of a particular feature are morphologically realized, like for instance the interpretations for person in Latin (see (19)- (20) above), the mapping between feature structure and feature interpretations is as in Chomsky's proposal. Each interpretation is mapped onto attribute-value pairs. For the person feature in Latin, this is illustrated in (23).

(23) FULL MORPHOLOGICAL REALIZATION: PERSON IN LATIN

Interpretation	Morpheme	Feature Structure
1 st person	-o	[Person: 1]
2 nd person	-s	[Person: 2]
3 rd person	-t	[Person: 3]

Under the proposal in (21), morphological realization of the different interpretations of a feature determines the feature structure. If one of the interpretations is not morphologically realized, this interpretation is mapped onto an attribute. In that case, the syntactic representation of that feature involves an interpretable attribute. However, if all the interpretations of a feature are morphologically realized, the interpretations are all mapped onto attribute-value pairs. In that case, there is no interpretation that is mapped onto the attribute itself. Hence, the syntactic representation of the feature involves an uninterpretable attribute, i.e. an attribute that cannot receive an interpretation at the CI-interface in case it has no value. I, however, argued above that uninterpretable attributes were theoretically suspect; see the discussion of Chomsky's feature system. Why do we then have an uninterpretable attribute in case all interpretations are morphologically realized?

The answer to this question is that this is the result of a trade off between economical mapping and learnability. In principle, mapping one of the feature interpretations onto the attribute, as in the obligatory underspecification proposal and in (22) above, is more economical than mapping all feature interpretations onto attribute-value pairs. In order to express two different interpretations, only one value and one attribute are needed in the former case. In order to express the same two interpretations in the latter case, two values and an attribute are needed.

As I showed above, a feature structure in which one of the interpretations of the feature is, however, mapped onto the attribute faces a learnability problem in case all interpretations of a feature are morphologically realized. The L1 learner cannot determine which of the interpretations should be mapped onto the attribute. This was the learnability problem from which the obligatory underspecification system suffered. In order to get around this problem, the L1 learner resorts to the less economical option of mapping all interpretations onto attribute-value pairs. In this way, morpho-driven feature structure gets around the learnability problem of the obligatory underspecification feature system.

In addition, it is also not confronted with the learnability problem of the Chomskyan feature system. In case one feature interpretation is morphologically not realized, this interpretation is mapped onto an attribute. Hence, there is no need to postulate a value for which morphological evidence is not present in the input. In this way, morpho-driven feature representation ensures that the syntactic representation of features is acquired by the L1 learner without any problem.

As argued above, a morphologically unrealized feature interpretation is mapped onto an attribute in morpho-driven feature representation. In case one of the feature interpretations is not morphologically realized, the attribute of that feature is interpretable. However, if all interpretations of a particular feature are morphologically realized, no interpretation is mapped onto the attribute. In that case, the attribute is uninterpretable. Below, I will show that this difference has important consequences for the mechanisms of Agree. These consequences will play a crucial role in my analysis of the strong-weak distinction in adjectival agreement. Moreover, whether an interpretation of a feature is morphologically realized or not can potentially differ from language to language, as already indicated above. Under my proposal in (21), this would mean that the syntactic representation of the same feature could also differ crosslinguistically. Before analyzing the strong-weak distinction in a particular language, I will therefore determine the syntactic representation of the features that are involved in adjectival agreement. This will show that there is indeed crosslinguistic variation with respect to the syntactic representation of features. This variation will provide an interesting account for some crosslinguistic differences concerning distinctions expressed by the weak adjectival inflection, especially with respect to some particularities of the German weak adjectival inflection, discussed in chapter 5. However, I will now first discuss the way in which Agree is established in narrow syntax.

2.2. The theory of Agree

After having discussed the syntactic representation of the features involved in agreement, I will now take a closer look at how agreement is licensed in narrow syntax. As stated above, the syntactic relation that is responsible for this licensing is Agree (Chomsky 2000, 2001). In order to remind the reader of the basic terminology, Agree is a relation between two syntactic nodes, a Probe and a Goal (Chomsky 2000, 2001). The Probe is the syntactic node that corresponds to the element displaying agreement. The Goal on the other hand is the node that corresponds to the element that determines the agreement. In chapter 3, I have already discussed in detail how the structural condition on Agree, i.e. the Probe-Goal configuration in which Agree can take place, is best characterized. Although I will briefly come back to this structural condition, the main focus of this subsection will be on other aspects of the syntactic licensing of agreement. I will address the following issues: the definition of probehood, the motivation for Probes to search a Goal, the Agree-relation itself and the situations in which the Probe stops its search. I will make a number of assumptions concerning these issues. Most of the assumptions I make are fairly standard. However, the implementation of some of these assumptions will differ slightly from those in other work on Agree. Together, the assumptions introduced in this subsection will form a theory of Agree, i.e. a theory about the syntactic licensing of agreement. This theory will then be used in the following sections to account for the strong-weak distinction.

The first issue I address is the definition of the Probe. I follow Chomsky (2001) and Pesetsky & Torrego (2004) by assuming that the defining property of Probes is that they are underspecified for one or more morphosyntactic features. Put differently, Probes are those elements that carry at least one feature representation consisting of an attribute without a value. This definition of Probe is given in (24).

- (24) UNDERSPECIFICATION OF THE PROBE (1ST AND FINAL VERSION)
 A syntactic node is a Probe with respect to a particular feature in case
 the representation of that feature on the relevant node is underspe-
 cified, i.e. consists of an attribute without a value.
 (cf. Chomsky 2001; Pesetsky & Torrego 2004, among others).

Under this definition, Probes start off the derivation with only a minimal specification of the features that they will display agreement for. In this way, a syntactic node can only be a Probe for a particular kind of feature, not for a particular value/interpretation of that feature.¹⁴ A node can thus be a Probe for number, but not for plural.

In light of this view on Probes, the morpho-driven feature representation I proposed in section 2.1 has an undesirable consequence for what counts as a Probe. Under morpho-driven feature representation, it is possible that an attribute without a value is interpretable at the CI-interface. I claimed for instance that singular number in English is syntactically represented as the number attribute without a value, i.e. as

¹⁴ Unlike for instance in a theory in which elements displaying agreement are fully specified for a particular instance of a feature, like for instance in Chomsky's (1995) checking theory of agreement.

[#:] (see (22) above). On this view, singular nouns are syntactically represented by a N node carrying [#:]. In the definition in (24), there is no reference to the CI-interpretability of the underspecified feature. Therefore, any node carrying an attribute without a value is a Probe, no matter whether the attribute in question is interpretable at the CI-interface without a value or not. Under the definition in (24) and morpho-driven feature representation, a singular N would thus be a number Probe in English. This does not seem to be right. N does not display number agreement. Instead, it is inherently specified for number.

One might think that a way around this problem might be to specify that probing features are not only underspecified, but also uninterpretable. The definition of probehood would then be as in (25).

- (25) UNDERSPECIFICATION OF THE PROBE (2ND AND UNDESIRABLE VERSION)
 A syntactic node is a Probe with respect to a particular feature in case the representation of that feature on the relevant node is underspecified, i.e. consists of an attribute without a value, and is uninterpretable.
 (cf. Chomsky 2001; Pesetsky & Torrego 2004, among others).

Specifying that the probing features are uninterpretable like in (25) solves the problem of interpretable underspecified features. If an attribute without a value is interpretable on a particular node, that node would not constitute a Probe under (25). However, specifying that a Probe should have uninterpretable features suffers from a serious problem. As pointed out by Chomsky (2001) and Pesetsky & Torrego (2004), interpretability is the capacity of a particular feature to make a contribution to the semantic interpretation of the object on which it is found. Hence, the interpretability or uninterpretability of a feature is a semantic property, not a syntactic one. If probehood were to depend on interpretability, narrow syntax would thus be crucially dependent on a property that is established at the interface with the semantic component. Given that the semantic component is situated after narrow syntax in the minimalist model of the grammar, encoding probehood in terms of interpretability would thus necessarily involve look-ahead.^{15,16}

Given this look-ahead problem, I reject the definition of Probes in (25). Instead, I claim that (24) is the correct definition of Probes. As a consequence, attributes without a value that are interpretable can indeed trigger Agree in narrow syntax. I suggest that these instances of Agree are filtered out at the interfaces. At the interfaces, interpretability is established. Hence, filtering out these unwanted Agree relations on the basis of interpretability would not involve look-ahead. However, I will leave to further search the issue of how exactly unwanted Agree-relations are filtered out at the interfaces. I will now continue to introduce the other assumptions I make about the way in which agreement is licensed in narrow syntax.

¹⁵ For this reason, Chomsky (2001) proposes that attributes without values, or ‘unvalued features’ are always uninterpretable. However, I rejected this option in section 2.1 because of the learnability problem such a feature system poses to the L1 learner.

¹⁶ The definition in (25) does not only suffer from a look-ahead problem. It is also incompatible with a system in which a Probe after Agree becomes interpretable, as in Pesetsky & Torrego (2004).

Probes search for Goals to Agree with. I follow Chomsky (2001) and Pesetsky & Torrego (2004) by assuming that this search is motivated by the urge of the Probe to further specify its probing features, i.e. to provide a value for the probing attribute without a value, as in (26).

- (26) SEARCH TRIGGER: SPECIFYING THE PROBE
Probes look into their search domain for a suitable Goal in order to further specify their underspecified features, i.e. to provide a value for the probing attribute. (Chomsky 2001, Pesetsky & Torrego 2004, among others)

This trigger for the search initiated by the Probe forms the second component of the theory of Agree that I adopt.

The third component of the theory of Agree is the structural condition on Agree. The previous chapter was entirely devoted to finding the most accurate definition of this condition. Towards the end of that chapter, I adopted the dominance requirement, ‘a Probe must dominate a Goal’, as the best definition of this condition. Although it covered a similar empirical domain as the c-command requirement I considered, I chose the dominance requirement for reasons of theoretical simplicity.

Another way of looking at the structural condition on Agree is in terms of the search domain of the Probe. From that perspective, the dominance requirement can be reformulated as in (27).

- (27) SEARCH DOMAIN OF THE PROBE (DOMINANCE REQUIREMENT)
The Probe searches for a Goal in the syntactic structure that it dominates (cf. chapter 3)

In the case of a number Probe X, the search domain is everything that is dominated by X. As a terminal node, X does however not dominate any syntactic structure. Only after X is merged with its complement, X dominates syntactic structure. This is shown in (28). In (28), X is merged with its complement ZP. This results in a new syntactic object that under Bare Phrase Structure has the same label as X. I argued in chapter 3 that this is the result of the terminal node that projects and the node that is created by merge share the same (instance of) label X. Because probing features are part of the label (see the previous chapter), the top node in (28) is also a number Probe. Contrary to the terminal node, this node dominates syntactic structure, namely ZP. Therefore, the search domain of the probing number feature that is part of the label X is in (28) ZP and everything contained in ZP.

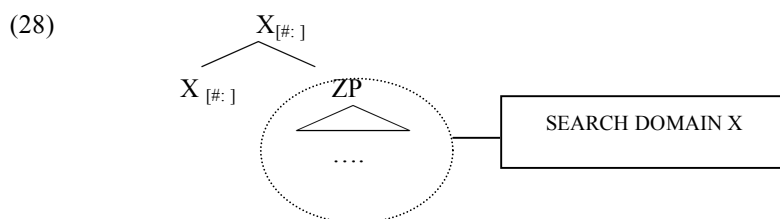

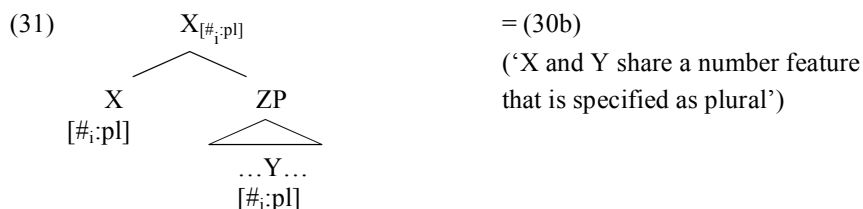

Note that the indices in (31) are not theoretical primitives. Instead, they are just notational devices used to indicate feature sharing.

As pointed out by Frampton & Gutmann (2000, 2006) and Pesetsky & Torrego (2004), there is a crucial difference between the feature sharing view of Agree and Chomsky's (2001) version of Agree. Agree as feature sharing allows for Agree even when the relevant feature on the Goal is as underspecified as the probing feature of the Probe.¹⁷ This is excluded under Chomsky's (2001) version of Agree. Under Chomsky's view, Agree assigns a value from the Goal to an attribute without a value on the Probe. From that perspective, Goals always need to be fully specified for the probing feature, i.e. they need to carry an attribute with a value. This is not necessarily the case under the feature sharing view of Agree. Nothing inherent to the feature sharing approach dictates that the feature of the Goal that is shared with the Probe should be more specified than the probing features it replaces on the Probe. The Probe will just share features with the closest element in its search domain that has the relevant features, no matter whether these are underspecified or fully specified. In contrast to Chomsky's (2001) approach to Agree, the Goal can on the feature sharing approach thus either be fully specified, as in (31), or underspecified for the feature that the Probe seeks. In this way, it is possible under the feature sharing approach that a number Probe enters into Agree with a Goal that has an underspecified number feature. This is shown in (32).¹⁸

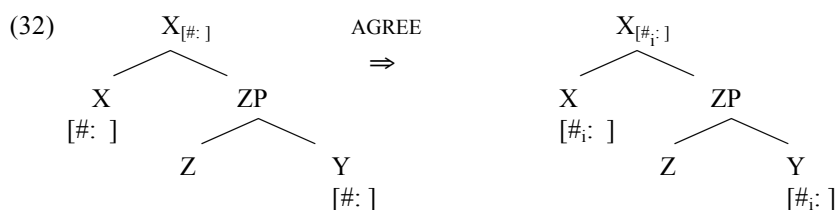

Another difference with Chomsky's (2001) version of Agree is that, on the feature sharing view, a syntactic object that is a Probe at a given stage of the derivation can always become a Goal for a higher Probe at a later stage. To this respect, it does not

¹⁷ Haegeman & Lohndal (to appear) propose a definition of Agree that also allows for Agree to be established between two unvalued/underspecified features, just like on the feature sharing view of Agree that I adopt here. However, Haegeman & Lohndal's view of Agree differs in other respects from the feature sharing view.

¹⁸ Note that label-sharing ensures that not only X(P) is associated with the number feature of Y, but that X is as well. See the discussion of (30) above.

matter whether this syntactic object is successful in triggering Agree itself as a Probe before serving as a Goal, because both underspecified and fully specified features can be shared under the feature sharing view of Agree. On the definition of Probes in (24) above, a syntactic node is a Probe in case it has an underspecified feature. If a Probe fails to enter into an Agree relation, this feature remains underspecified. A higher Probe can still target it as a Goal at a later stage of the derivation, as feature sharing can involve underspecified features. If a Probe enters into an Agree relation, it is either associated with a fully specified feature in case the Goal is fully specified, or with an underspecified feature in case the Goal is underspecified. In both cases, a higher Probe can target this Probe as a Goal at a later stage of the derivation. In my analysis of adjectival inflection in Germanic, this property of a Probe becoming a Goal for a higher Probe will play an essential role.

Above, I claimed that the search initiated by the Probe is triggered by the need to specify underspecified features, i.e. to find a value for the probing attribute (see (26) above). As a consequence of this, the Probe will continue to search its domain until either the probing feature is replaced by Agree with a fully specified feature or until all the nodes in the search domain are inspected. Formulated differently, there are thus two cases in which the search of the Probe is halted; either the trigger for the search is satisfied as a result of Agree or the domain of the search is exhausted without Agree taking place, (33).

- (33) WHEN PROBING STOPS:
 The Probe stops its search for a Goal, when (a) or (b)
- a. the Probe shares with a Goal a fully specified feature of the type that triggered search (*trigger satisfaction*)
 - b. all the syntactic nodes in the search domain are inspected (*search domain exhaustion*)

The conditions in (33) constitute the fifth component of the theory of Agree. On the feature sharing view, Agree can be established with a Goal that is underspecified for the probing feature, as I explained above. In that case, the Probe will remain active because the urge of the Probe to specify its features is not satisfied. The Probe will therefore continue to search for a Goal. Put differently, Agree does not necessarily put an end to the Probe's search. This search is only ended if one of the conditions in (33) is met.

The assumptions that I introduced above together form the theory of how Agree relations come about in narrow syntax. I will now examine how these relations are handled at the interfaces.

2.3. The theory of Agree and the interfaces

Agree alters the feature specification of Probes. Therefore, the question of how Agree relations are interpreted at the interfaces is the same as the question of how the nodes that act as Probes in narrow syntax are interpreted at the interfaces. Given the theory of Agree as presented in section 2.2, there are three different scenarios for

Probes with respect to Agree. First, Probes can fail to enter into an Agree relation. Secondly, Probes can enter into an Agree relation with a Goal that is fully specified for the feature they seek. Finally, Probes can Agree with a Goal that is underspecified for the feature they search for. In sections 4 and 5 of this chapter and in chapter 5 below, I will show at length that each of these scenarios is instantiated in the patterns of adjectival inflection in Germanic. In order to facilitate the discussion, I take in this section a closer look at the details of each scenario. I will first show that the outcomes of these three scenarios are different with respect to the activeness of the Probe and its feature specification. After having introduced these differences in more detail, I explain how the interfaces handle Probes under each scenario.

2.3.1. Three scenarios for Probes

Under the first scenario, there is no element in the search domain of the Probe that is specified for the feature the Probe seeks. Put differently, there is no Goal in the search domain. This scenario is illustrated in (34) for a number Probe. In (34), the number Probe is contained in the label X. Under the dominance requirement on Agree, the search domain of the number Probe in (34) is ZP. However, ZP does not contain any elements with a number feature.

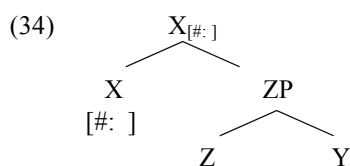

Under this scenario, the Probe scans its entire search domain for a Goal without any success. Once the entire search domain is scanned, the Probe stops searching for a Goal (see (33b)). The derivation then continues until the interfaces are reached. Because it did not find a Goal to enter into an Agree relation with, the Probe reaches the interfaces without sharing its underspecified probing feature with another element. In the case of (34), X thus reaches the interfaces with an unshared number attribute without a value.

In the second scenario, the search domain of the Probe contains an element that is fully specified for the feature that the Probe seeks. In other words, the search domain of the Probe contains a Goal that carries an attribute-value pair of which the attribute matches the probing attribute. While scanning its search domain, the Probe finds this Goal and Agrees with it. This results in the Probe and Goal sharing the fully specified feature that originated on the Goal. As the Probe is now associated with a fully specified feature, the trigger for searching a Probe, i.e. the urge to specify underspecified features (see (26)), is now satisfied. Hence, the Probe will not look any further for a Goal in its search domain. Put differently, Agree with a fully specified Goal deactivates the Probe. The syntactic derivation then continues until it reaches the interfaces. Under this scenario, the Probe thus reaches the

interfaces while being associated with a fully specified feature that is shared with the Goal.

In section 2.2, I illustrated this scenario with the number Probe X in (30) and (31), repeated here in (35). This Probe enters into an Agree relation with a number feature that is specified as plural. This will deactivate X as a Probe. Put differently, X will not search any further for a Goal.

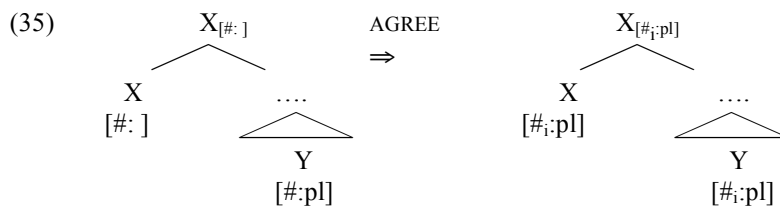

At the interfaces, X will thus be sharing with Y a number feature that is specified as plural.

In the third and final scenario, the search domain of the Probe contains an element with an underspecified instance of the feature that the Probe seeks. While scanning its search domain, the Probe finds this element and enters into an Agree relation with it. Agree results in this case in the sharing of an underspecified feature. This scenario was illustrated for a number Probe in section 2.2 in (32), repeated below in (36).

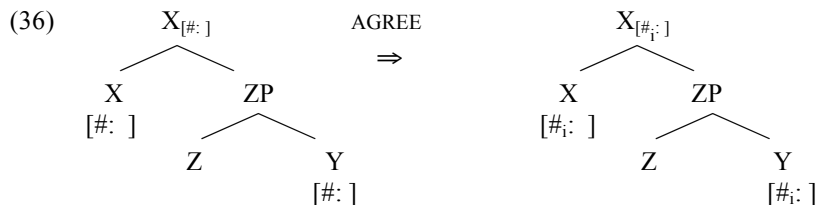

However, the sharing that associates the underspecified feature of the Goal with the Probe does not satisfy the trigger of the Probe to search for a Goal. As stated in (26), a Probe searches a Goal in order to replace its underspecified feature with a specified instance of that feature. In this scenario, the feature of the Goal is as specified as that on the Probe. Hence, Agree in this case does not deactivate the Probe. After Agree, the Probe will therefore continue to scan its search domain looking for a Goal. During this further search, any of the three scenarios I just discussed is possible. The Probe might not find another Probe in its search domain (scenario 1) or it might find a fully specified Probe (scenario 2) or an underspecified Probe (scenario 3).

In this way, the Probe will continue to search for a Probe, entering into an Agree relation with all underspecified Probes on the way, until it enters into Agree with a fully specified Probe or until there are no more nodes in the search domain to inspect. This is schematized in the flow chart in (37)

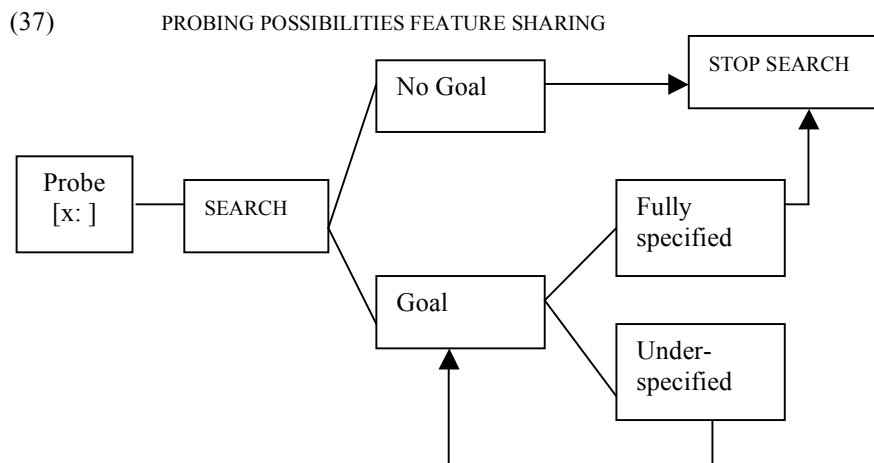

The three scenarios sketched above differ with respect to the specification of the Probe after Agree, whether the Probe shares a feature with the Goal (i.e. whether there is Agree or not) and whether Agree bleeds further search by the Probe. These differences are summarized in the table in (38).

(38) DIFFERENCES BETWEEN THE THREE DIFFERENT SCENARIOS FOR PROBES

Scenario	Probe specification after Agree	Shared Feature	Bleeds further search by the Probe
#1	Underspecified	No	d.n.a.
#2	Fully specified	Yes	Yes
#3	Underspecified	Yes	No

The differences in the specification of the Probe and feature sharing that set scenarios 2 and 3 apart from scenario 1 must also have effects at the SM- and CI-interfaces. If this were not the case, Agree would have no effect at the interfaces. Given the persistent presence of agreement morphology in natural language, this cannot be true. Hence, the question arises how the interfaces deal with these differences.

2.3.2. Interface conditions

The question of how Probes are interpreted at the interfaces has received a considerable amount of discussion in the literature (cf. Chomsky (2000, 2001) and Pesetsky & Torrego (2004)). According to Chomsky (2001), all probing features are uninterpretable at the CI-interface. In his system, Agree is a necessary prerequisite for the deletion of these features. If deletion does not take place before the derivation reaches the interfaces, the CI-interface would be confronted with features that it cannot interpret. This would cause the derivation to crash. Pesetsky & Torrego (2004) challenge Chomsky's view. They argue that it is possible to have

probing features that are interpretable at the CI-interface. In the case of these interpretable probing features, they propose that Agree is necessary to correctly interpret these at the CI-interface. They illustrate this by providing an analysis of the tense feature in English. According to them, T in English has an interpretable probing feature for tense. This means that T has an interpretable feature that is unvalued. T enters into an Agree-relation with V, which has an uninterpretable but valued tense feature. This instance of Agree ensures that the right value of the tense feature is assigned to T. Although probing features can be interpretable according to Pesetsky & Torrego (2004), they need not be. In the case of number agreement on T, the number Probe on T is clearly uninterpretable. On Pesetsky & Torrego's view, the interpretability of probing features simply depends on the category of the Probe. Number features are, for instance, interpretable on N, but uninterpretable on T or A.

The features involved in adjectival agreement (number, gender, and case) do not make any contribution to the semantic interpretation of the adjective. In that sense, these probing features on A would be uninterpretable on Pesetsky & Torrego's (2004) view. On Chomsky's view, these probing features on A would also be uninterpretable, given that he takes all probing features to be uninterpretable. For my analysis of adjectival agreement, it therefore does not matter which of the two views I adopt. I simply assume that it is somehow possible for the CI-interface to determine whether a feature is interpretable or not. In addition, I assume that features that are uninterpretable at a certain syntactic node are just ignored by the CI-interface without leading to a crash of the derivation, (39).

- (39) CI-INTERPRETATION
 If a feature cannot be interpreted on a particular node at the CI-interface, the CI-interface ignores that feature at the node in question.

There is a crucial difference between (39) and Chomsky's concept of uninterpretable feature deletion. As mentioned above, Chomsky proposes that uninterpretable features are deleted before they reach the CI-interface. However, this is incompatible with the feature sharing view of Agree that I adopt. Under the feature sharing view, the outcome of Agree is a single feature that is associated both with the Probe and the Goal. This feature might be uninterpretable at the Probe, but interpretable on the Goal. If the feature gets deleted because it is uninterpretable at the Probe, its interpretation on the Goal is however also rendered impossible. This is an undesirable side effect. Under (39), the feature as such remains intact. The CI-interface just ignores the association with that feature at a location in which the feature is uninterpretable. In other words, the association with the feature is deleted, not the feature itself (see also Pesetsky & Torrego 2004).

As mentioned above, Chomsky proposes that Agree is a prerequisite for uninterpretable probing features to be deleted. Pesetsky & Torrego (2004: 4) point out that this link between Agree and deletion is stipulated. In Chomsky's system, probing features are uninterpretable at the CI-interface, no matter whether Agree takes place or not. Why could the probing features not simply be deleted without Agree? In order to avoid this stipulation in Chomsky's system, I take (39) to apply to all uninterpretable features whether they participate in an Agree relation or not. This has an important consequence: the failure of a Probe to Agree cannot induce a

crash of the derivation at the CI-interface. If it does not enter into an Agree relation, an uninterpretable probing feature is just ignored by the CI-interface, instead of causing a crash of the derivation at the CI-interface. On this view, Agree takes place whenever possible, i.e. whenever there is a Goal in the right syntactic configuration (see also Preminger 2008, Frampton & Gutmann 2006), triggered by the need of the Probe to further specify its probing features (see section 2.2.). If, however, Agree is impossible for some reason, the derivation does not crash at the CI-interface.

Preminger (2008) shows that there is empirical evidence to support such a view of Agree. This empirical evidence is constituted by the observation that the failure to Agree leads in some cases to default agreement morphology on the Probe, instead of an ungrammatical sentence. Consider for instance the Basque sentences in (40), taken from Preminger (2008: 3).¹⁹ These sentences have an ergative third person plural *pro* as their subject.

- (40) a. *Harri horiek altxa-tze-n probatu* [Basque]
stone(s) those.PL.ABS lift-NMZ-LOC attempt
d-it-u -zte
 3.ABS-PL.ABS-have-3PL.ERG
 ‘They have attempted to lift those stones’
- b. *lankide-e-i liburu horiek irakur-tze-n probatu*
 colleague-ART.PL-DAT book those.PL.ABS read-NMZ-LOC attempt
*d-∅/*it-u-(z)te*
 3.ABS-SG.ABS/PL.ABS-have-3.PL.ERG
 ‘They have attempted to read those books to the colleagues’

In (40a), the main clause auxiliary, *dituzte*, is marked for agreement with *Harri horiek* ‘those stones’, the absolutive argument of the embedded predicate. In (40b), the dative argument *lankideei* ‘to the colleagues’ blocks Agree between the main clause auxiliary and *liburu horiek* ‘those books’ the absolutive argument of the embedded predicate. This does however not lead to ungrammaticality. Instead the main clause auxiliary takes a default form for absolutive agreement (third person singular). The data in (40) constitute in this way an empirical argument in favor of the idea that the failure to Agree does not cause a crash at the interface.

The way in which the outcome of Agree is handled at the SM-interface is not as much at the forefront of discussion as the interpretation at the CI-interface. Given the persistent presence of agreement morphology on Probes, it is obvious that the features on the Probe that participate in Agree must be interpreted at the SM-interface. This makes that there is a discrepancy between the two interfaces concerning the interpretation of the features on the Probe that participate in Agree. At the CI-interface, these features can be uninterpretable (see the discussion above). At the SM-interface, they are interpretable. In Chomsky (2001)’s system, this discrepancy is implemented by deleting these features only when they are sent to the CI-interface, but not when they are sent to the SM-interface.

¹⁹ Some glosses in (40) are not used elsewhere in this thesis: ABS=absolutive, ERG=ergative, ART=article, LOC=locative and NMZ=nominalizer.

However, in the framework adopted here, I cannot follow Chomsky (2001) and assume that probing features are always interpreted at the SM-interface but in some cases not at the CI-interface. If this were the case, there would be no distinction at the SM-interface between a Probe that did not enter into an Agree relation (scenario 1 in section 2.3.1) and a Probe that entered into Agree relation with a Goal that is underspecified for the probing feature (scenario 3 in section 2.3.1). In both these scenarios, the Probe reaches the interfaces with an underspecified probing feature. Hence, these two scenarios cannot be distinguished on the basis of the specification of the Probing features. The two scenarios were illustrated in (35) and (34) above for a number Probe. They are repeated here in (41).

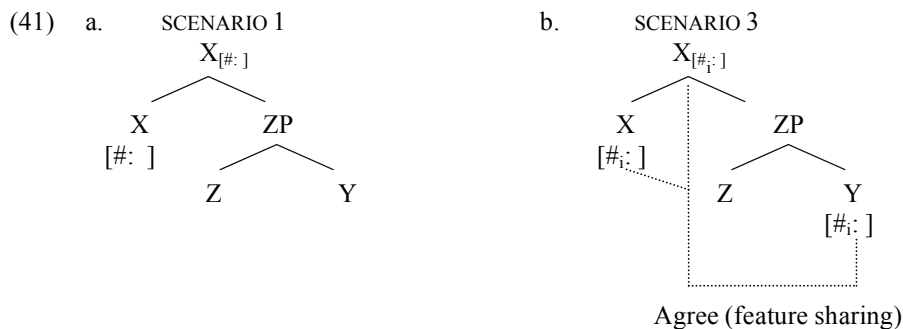

If Probes were treated in the same way at the SM-interface in both cases, it would be impossible for the morphological component to distinguish between the absence of Agree in (41a) and Agree involving an underspecified feature, like number in (41b). However, I claim that morphology is sensitive to this difference. In chapter 5, I will show that the German weak adjectival inflection receives a straightforward explanation if morphology can distinguish between a Probe that failed to Agree and a Probe that Agreed with an underspecified Goal. In order to achieve this, interpretation at the SM-interface should hence be sensitive to whether probing features are involved in an Agree relation or not. Under the feature sharing view of Agree, features are shared between the Probe and the Goal. These features are generally CI-interpretable on the Goal, but CI-uninterpretable on the Probe. Probes that fail to establish Agree hence differ at the interfaces from those that succeed in doing so in that their probing features are not replaced by features that are also associated with a position on which they are CI-interpretable, i.e. with the Goal. I propose that this difference is relevant for interpretation at the SM-interface. More precisely, I propose that in order for a feature to be interpreted at the SM-interface, it must be interpretable at the CI-interface at one of the positions it is associated with.²⁰ This condition is stated in (42).^{21,22}

²⁰ This proposal is similar to Brody's (1997) thesis of radical interpretability, which states that each feature must receive a semantic interpretation in some syntactic location. It is different from Brody's thesis of radical interpretability in that it explicitly limits the number of location a feature is CI-interpreted in to one and that it makes explicit reference to the SM-interface.

(42) CI-DEPENDENT SM-INTERPRETATION

A feature is interpreted at the SM-interface in all the positions it is associated with if it is CI-interpretable in one of these positions. In case it is not associated with a position in which it is CI-interpretable, the feature is ignored at the SM-interface in all the positions it is associated with.

The condition in (42) allows for a certain discrepancy between SM- and CI-interpretability. The condition is stated in such a way that it does not require that a feature is CI- and SM-interpretable in the same position. On the other hand, the condition in (42) prevents this discrepancy from getting out of hand. This is achieved by requiring that a feature must at least be interpreted at the CI-interface in one of the positions it is associated with.

If a Probe fails to establish Agree as in (41a) (scenario 1 of section 2.1), the probing features are only associated with the Probe. Given that they are CI-uninterpretable on the Probe, the condition in (42) is not satisfied.²³ Hence, the probing features are ignored at the SM-interface without inducing a crash of the derivation. If on the other hand, the Probe enters into an Agree relation, as in (41b) (scenario 3 of section 2.1), the features that participate in Agree are not only associated with the Probe but also with the Goal. On the Goal, these features are CI interpretable. Hence, the condition in (42) is met and the features that participate in Agree are interpreted at the SM-interface. This also holds for scenario 2 of section 2.3.1, in which the shared feature with the Goal is fully specified. The SM-interpretability of the probing features under the three scenarios are summarized in the table in (43)

(43) SM-INTERPRETABILITY OF PROBING FEATURES

Scenario	Shared Feature	Probe specification at the SM-interface	SM-interpretability
#1	No	Underspecified ²⁴	-
#2	Yes	Fully Specified	+
#3	Yes	Underspecified	+

By adopting CI-dependent SM-interpretation condition in (42) and the CI-interpretation condition in (39), I adopt a view of Agree that is similar to that of

²¹ Note that the condition in (42) requires a model of the grammar in which the SM-interface is able to communicate with the CI-interface. I leave the exact details of such a model to further research.

²² SM-interpreted in this definition means submitted to the morphological component of the grammar. This submission is a prerequisite for phonological realization, but not a sufficient condition. Later operations in the morphological component (like Chain Reduction, see chapter 2) might prevent an element submitted to the SM-interface from being phonologically realized.

²³ In order to simplify the discussion, I abstract away from the possibility of CI-interpretable probing features (see above).

²⁴ An underspecified feature consists of only an attribute. Fully specified features consists of an attribute and a value.

Preminger (2008) and Frampton & Gutmann (2006) in that the failure to undergo Agree can never induce a crash at the interfaces. Agree takes place in Narrow Syntax whenever the right conditions are met (cf. section 2.2 for these conditions). If these conditions are however not met, the derivation just continues without crashing at the interfaces.

2.4. Summary

In this section, I introduced the theoretical tools that I will use to account for the patterns of attributive adjectival agreement in Germanic. These tools consist of detailed proposals concerning morphosyntactic features, the fine mechanisms of Agree and the way in which features are interpreted at the interfaces.

I propose a feature system in which morphologically realized feature interpretations correspond to attribute-value pairs in the syntactic representation of these features, while morphologically unrealized interpretations correspond to attributes without values. I further adopt the idea that Probes enter the syntactic derivation with underspecified probing features. The Probe initiates a search for a Goal in order to further specify these features. The search by the Probe is only halted when Agree provides the probing features with a specification or when the search of the Probe has exhausted its search domain. The search domain of the Probe is defined in terms of the dominance requirement of chapter 3. In addition, I adopt Frampton & Gutmann's idea that Agree is feature sharing. Finally, I propose that the SM-interface interprets probing features only when these features are also interpretable at the CI-interface at one of the positions they are associated with.

These theoretical tools will permit to evaluate in full detail the proposals of the adjectival agreement that I will advance in the following sections. They will enable me to properly calculate the results of these proposals for each of the cells in paradigms of adjectival inflection.

3. Agreement on attributive adjectives in Germanic

Now that I have laid the theoretical groundwork, I return to agreement on attributive adjectives in Germanic. In this section, I will introduce in general terms the essence of my proposal for the strong-weak distinction. In the following sections and chapter 5, I will then illustrate in detail how this proposal accounts for the agreement facts in a number of Germanic languages.

As mentioned in the introduction to this chapter, the inflection on attributive adjectives in most Germanic languages displays a strong-weak distinction. If it carries strong inflection, the adjectives displays agreement with the noun it modifies. In Swedish, adjectives with strong adjectival inflection for instance display gender and number agreement with the noun, cf. (2) above repeated here in (44). However, if it carries weak inflection, the adjective does not display full agreement with the noun. It either does not agree at all, as in Swedish, or it displays only partial agree-

ment, as in German (to be discussed in chapter 5 below). The absence of agreement on Swedish adjectives with weak inflection was shown in (3), repeated here in (45).

- (44) a. *en* *ung-Ø* *flicka* NON-NTR, SG, INDEF
 a.NON-NEUTER young-NONNEUTER girl
 ‘a young girl’
- b. *ett* *stor-t* *hus* NEUTER, SG, INDEF
 a.NEUTER big-NEUTER house
 ‘a big house’
- c. *två* *ung-a* *flick-or* NON-NTR, PL, INDEF
 two young-PL girl-PL
 ‘two young girls’
- d. *två* *stor-a* *hus- Ø* NEUTER, PL, INDEF
 two big-PL house-PL
 ‘two big houses’
- (45) a. *den* *ung-a* *flicka-n* NON-NTR, SG, DEF
 the.NONNEUTER young-WEAK girl-DEF.NONNEUTER
 ‘the young girl’
- b. *det* *stor-a* *hus-et* NEUTER, SG, DEF
 the.NEUTER big-WEAK house-DEF.NEUTER
 ‘the big house’
- c. *de* *stor-a* *hus-en* NEUTER, PL, DEF
 the.PL big-WEAK house-DEF.PL
 ‘the big houses’
- d. *de* *ung-a* *flick-or-na* NON-NTR, PL, DEF
 the.PL young-WEAK girl-PL-DEF
 ‘the young girls’

I will first introduce my account of the agreement expressed by the strong adjectival inflection and will then formulate my proposal of the lack of agreement in the weak adjectival inflection.

3.1. Strong adjectival inflection: Indirect Agree

In chapter 3, I argued that the agreement displayed on the adjective by the strong adjectival inflection poses a problem for the dominance requirement on Agree. According to the dominance requirement, the Probe has to dominate the Goal. On the label sharing view of projection (see chapter 3), this requirement is met as long as one of the nodes of the projection of the Probe dominates the Goal. In chapter 2, I adopted the view that attributive adjectives are adjuncts to DP. In that case, none of the nodes that constitute the projection of the adjective dominates N. The adjectival Probe thus does not dominate the nominal Goal. Hence, the dominance requirement

predicts that a direct Agree relation between an attributive adjective and N is impossible, (46).²⁵

- (46) DOMINANCE REQUIREMENT: NO AGREE (ATTRIBUTIVE ADJECTIVES, NOUNS)

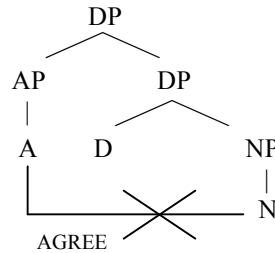

From this perspective, the agreement displayed by the strong adjectival inflection cannot be the result of a direct Agree-relation between the adjective and the noun. How should this agreement then be accounted for? I propose that this agreement is licensed indirectly as the by-product of the Agree-relations established by a higher Probe, instead of being the result of a direct Agree relation between the adjective and the noun.

As pointed out by Pesetsky & Torrego (2004), Bhatt (2005) and Adger (2007), the possibility of indirect licensing of agreement is a consequence of the feature sharing view of Agree.²⁶ On the feature sharing view of Agree, a Probe that cannot enter into a direct Agree relation with a particular Goal can still get to share features with this Goal in an indirect way with the help of another Probe. In order to appreciate this, consider (47). In (47), X is an adjunct or specifier, just like A in (46).

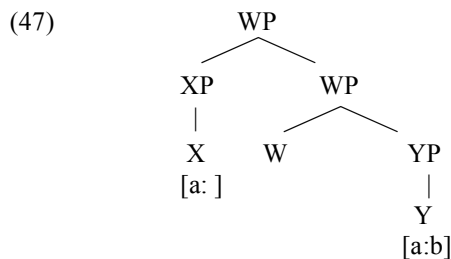

X is a Probe for the feature *a*. On the underspecification view of probehood I adopted (see (24) above), this means that it enters the derivation with an unshared underspecified feature *a*. Y in (47) carries a feature *a* that is specified as *b*. In principle, it is therefore a suitable Goal for X. However, no node of the projection of X dominates Y (cf. the adjective in (46)). No direct Agree-relation between X and Y

²⁵ This would also hold if adjectives are specifiers, not adjuncts.

²⁶ Pesetsky & Torrego (2004) use this indirect licensing for case assignment and basic agreement in English.

can therefore be established, since Y is not in the search domain of X under the dominance requirement. The derivation thus continues with X still carrying an underspecified and unshared feature *a*. Let's assume that at a later stage of the derivation a head Z is merged. Like X, Z is a probe for the feature *a*. However, unlike X, a projection of Z dominates WP, a constituent containing both X and Y. This is shown in (48a)

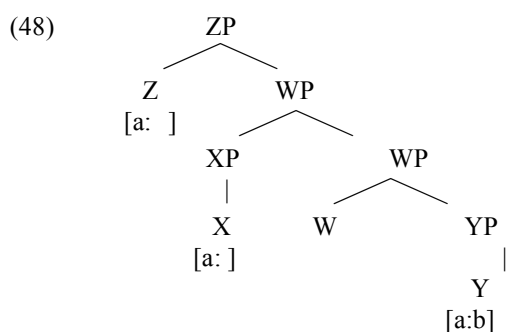

Under the dominance requirement, this makes WP the search domain of Z. The probe Z will therefore look into WP for any element that has the *a*-feature. The first element that Z will find with feature *a* is X, which carries an underspecified *a*-feature because of its own probehood (see above). As explained in section 2.2 above, any element in the search domain that has a feature of the kind requested by the Probe serves as a Goal under the feature sharing view of Agree, irrespective of the level of specification of this feature. Hence, Agree between Z and X is established, targeting X as a Goal. This results in an underspecified feature [a:] being shared between Z and X. This is shown in (49), in which the *i*-indices indicate feature sharing.

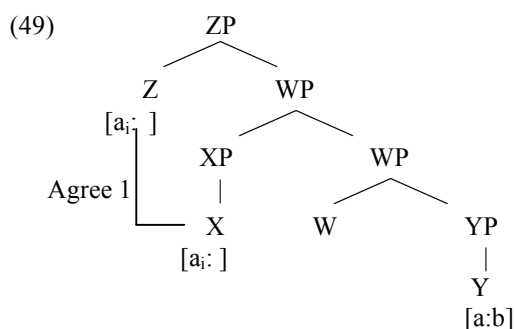

This instance of Agree does however not deactivate Z as a Probe. As argued in section 2.2, a Probe only stops looking for a Goal either if it is associated with a fully specified feature or if the search domain is exhausted, (see (33)). Hence, Z continues to look down its search domain for another Goal. It will then find Y, which is a suitable Goal because it carries a feature *a* that is specified as *b*. Z will therefore enter into an Agree relation with Y. This instance of Agree replaces the

underspecified feature a on Z with the fully specified feature a of Y . This results in $[a:b]$ being shared between Z and Y . However, the underspecified feature a , that is replaced on Z is also associated with X , as a result of *Agree 1* in (49). Hence, replacing this feature with the fully specified a feature of Y , does not only also associate Z with the fully specified feature of Y , but also X . This is shown in (50).

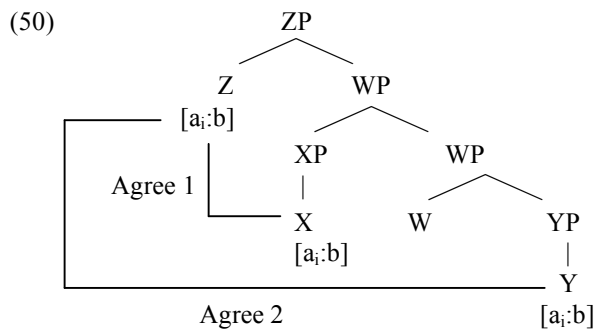

In this way, X ends up sharing features with Y without entering directly into an Agree relation with Y . Instead, this sharing of features is a by-product of Z first entering into an Agree-relation with X , *Agree 1* in (49)/(50), and then with Y , *Agree 2* in (50). Put differently, feature sharing between X and Y is rendered possible by Z , which mediates between X and Y . Since the feature sharing between Y and X is in a sense parasitic on the Agree relations that are triggered by the third element Z , this indirect licensing of feature sharing is also known as *Parasitic Agree* (cf. Bhatt 2005, Adger 2007). In order to more easily contrast instances of feature sharing that are the result of this indirect licensing with instances that are the result of a direct Agree relation, I will however refer to it as *Indirect Agree*.

As argued above (see (46)), attributive adjectives cannot enter into a direct Agree-relation with N , because none of the nodes of their projection dominates N . Instead, I claim that any agreement on attributive adjectives with features of N is the result of Indirect Agree. I will refer to this proposal as the *Indirect Agree Hypothesis*, (51).

- (51) INDIRECT AGREE HYPOTHESIS
 Agreement on attributive adjectives is licensed by Indirect Agree.

On the indirect Agree hypothesis, the agreement expressed on Germanic attributive adjectives with strong adjectival inflection is not the result of a direct Agree relation between the adjective and the noun. Instead, it is the result of a Probe first entering into an Agree relation with the attributive adjective and then with the noun. Because of these two Agree-relations, the adjective ends up sharing features with the noun without directly entering into Agree with it, just like X ended up in (50) sharing the $[a:b]$ -feature with Y . This is shown in (52) in which X is the Probe entering into Agree-relation with both the noun and the adjective.

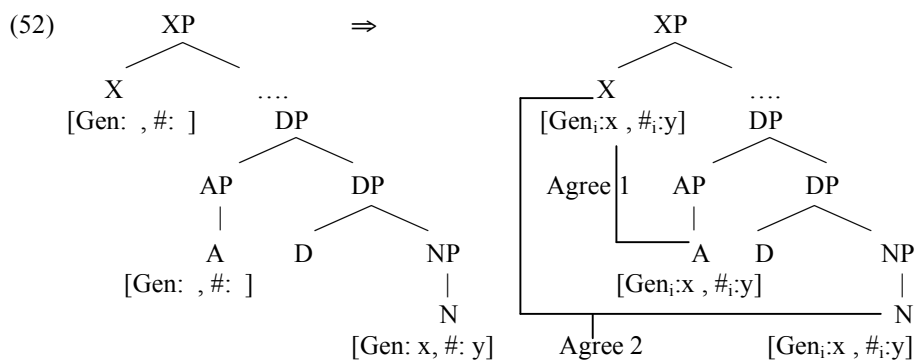

I claim that the Probe that renders feature sharing between the adjective and the noun possible as a result of Indirect Agree is the case assigner of the DP the adjective is contained in. X in (52) is thus T for nominative DPs and v for accusative DPs. According to Chomsky (2001), any case assigner is also a Probe for phi-features. I thus propose that the strong adjectival inflection is the result of the probing features of the case assigner first entering into an Agree relation with the adjective and then with the noun.

3.2. Weak adjectival inflection: Indirect Agree is blocked

Contrary to the strong adjectival inflection, weak adjectival inflection expresses no agreement, as for instance in Swedish (see (45) above), or partial agreement, as in German (to be discussed in the next chapter). This means that the Indirect Agree relation that licenses the agreement expressed by the strong adjectival inflection should be fully or partially blocked in those contexts in which adjectives receive weak adjectival inflection. In order to determine the cause of this blocking, I now take a closer look at the context in which weak adjectival inflection occurs.

In Swedish, adjectives with weak adjectival inflection occur in definite DPs, as in (53a). Adjectives with strong adjectival inflection occur in DPs introduced by the indefinite article or in DPs without an article. This is shown in (53b/c).

(53)	a.	<i>det</i>	<i>stor-a</i>	<i>hus-et</i>	DEFINITE: WEAK
		the.NEUTER	big-WEAK	house-DEF	
		'the big house'			
	b.	<i>ett</i>	<i>stor-t</i>	<i>hus</i>	INDEFINITE: STRONG
		a.NEUTER	big-NEUTER.SG	house	
		'a big house'			
	c.	<i>vacker-t</i>	<i>väder</i>		ARTICLELESS:STRONG
		beautiful-NEUTER	weather		
		'beautiful weather'			

In addition to adjectives carrying weak adjectival inflection, Swedish definite DPs with adjectives are characterized by other remarkable phenomenon, namely the doubling of the definite article (also known as double definiteness). As discussed in detail in chapter 2 and shown in (53a), these DPs contain two definiteness markers, a freestanding definite article that precedes the adjective and a definite suffix on the noun. In the contexts in which the adjective takes strong adjectival inflection, there is however no article doubling. For instance, the indefinite article that precedes the adjective with strong adjectival inflection in (53b) is not doubled. I claim this co-occurrence of article doubling and weak adjectival inflection is not a coincidence, but that the two phenomena are closely related.

In chapter 2, I analyzed the article doubling in Swedish definite DPs with an adjective as being the result of Internal Merge of the definite D, as shown in (54).

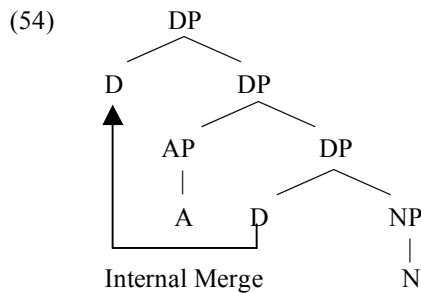

In chapter 2, I claimed that this internal merge of D takes place in all Germanic languages. I attributed the fact that this internal merge leads to article doubling in Swedish, Norwegian, and Faroese but not in other Germanic languages mainly to morphological variations among the Germanic languages. My proposal is that the lack of agreement expressed by the weak adjectival inflection is due to this instance of internal merge. In order to be more precise, I claim that internal merge of the definite D blocks the instance of Indirect Agree that licenses the agreement expressed by the strong adjectival inflection. This blocking is caused by the deactivation of the higher D-copy that is created by Internal Merge. I will now discuss this proposal in more detail.

Germanic definite Ds display gender and number agreement with the noun and, in some languages, also case agreement. In Swedish for instance, the definite article displays agreement in gender and number with N. This is illustrated in (55). If the noun has, for instance, neuter gender and appears in the singular, the definite article is spelled out as *-et*, as in (55a). If, on the other hand, the noun is singular non-neuter, it is spelled as *-en*, as in (55b).

- (55) a. *d-et* *stor-a* *hus-et*
 DEF.NEUT big-WEAK house-DEF.NEUT
 ‘the big house’
- b. *d-en* *stor-a* *bil-en*
 DEF.NONNEUT big-WEAK car-DEF.NONNEUT
 ‘the big car’

Germanic definite Ds are thus Probes for gender and number features (and in some languages also for case features). This probehood has consequences for the derivation of definite DPs. After the definite D is merged with N, the probing features on D will trigger (direct) Agree with N. This results in the sharing of features between D and N, as in (56).

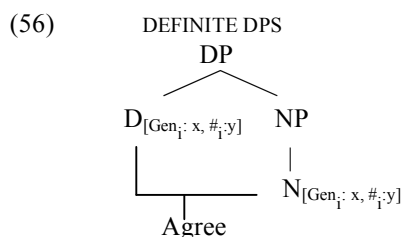

As a result of this sharing D is associated with features on N. It is therefore deactivated as a Probe.

Under the analysis proposed in chapter 2, adjectives are merged as adjuncts to DP. This adjunction triggers internal merge of D, as in (54) above. The higher D that is created by internal merge is an exact copy of the lower D. Given that the lower D-copy shares features with N as a result of Agree prior to internal merge of D (cf. (56)), the higher D-copy also shares features with N, as in (57). This makes the higher D-copy a deactivated Probe, like the lower D-copy.

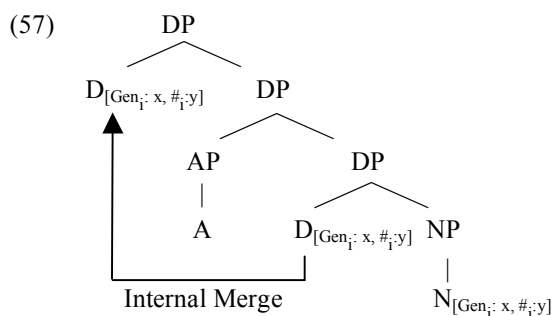

As discussed above, agreement on adjectives with strong inflection is licensed by Indirect Agree, i.e. by a Probe that enters into an Agree relation both with the adjective and the noun. In (57), both D-copies do not enter into an Agree relation with the adjective, since both copies are deactivated as a Probe before they can enter into an Agree relation with the adjective. The lower D-copy is deactivated as a Probe as a result of Agree with N prior to insertion of the adjective. The higher D-copy is deactivated, since it is an exact copy of the deactivated lower D-copy. Because of this deactivation, they cannot license agreement on the adjective via Indirect Agree.

Not only can definite Ds not license agreement on attributive adjectives via Indirect Agree, they also prevent other elements from doing so. As mentioned

above, I propose that the strong adjectival inflection is licensed by the case assigner of DP first entering into an Agree relation with A and then with N. In definite DPs, the phi-probing case assigner will never enter into Agree with A, since the higher D-copy always intervenes between the case assigner and A. As argued above, the higher D-copy shares phi-features with N by virtue of being an identical copy of the lower D. As a consequence, it constitutes the closest Goal for the DP-external case assigner. The case assigner will therefore enter into an Agree-relation with the higher D-copy. This will deactivate it as a Probe, blocking Agree between the case assigner and A. This is shown in (58), in which X represents any possible case assigner (i.e. T, v, etc.).

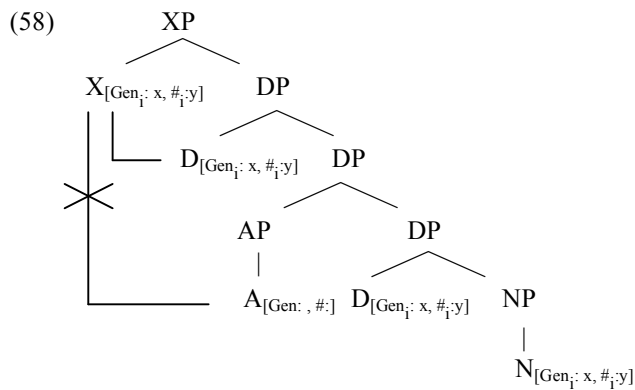

In this way, the higher D copy in definite DPs acts as a shield for DP-external Probes entering into Agree with A. This has the consequence that DP-external Probes like case assigners will not be able to license strong adjectival inflection on A via indirect Agree.

In definite DPs, it is thus impossible to associate A with the gender and number features on N through Indirect Agree. Such an association would require a number and gender Probe to first enter into Agree with A and then with N. However, I argued above that this is impossible in definite DPs for two reasons. First, DP-external Probes, like case assigners, never enter into an Agree relation with the adjective in definite DPs, because the higher D-copy is always a closer Goal for them. Second, the higher D-copy does not enter into Agree with A, because it is deactivated as a Probe. The adjective in a definite DP is thus never associated with the gender and number features on N, not through Direct Agree (because of the dominance requirement) and not through Indirect Agree. This explains the absence of gender and number distinctions of the weak adjectival inflection.

3.3. Outlook

In this section, I proposed that strong adjectival inflection should be analyzed in terms of Indirect Agree. Moreover, I attributed the lack of agreement on adjectives with weak adjectival inflection to D blocking Indirect Agree. In the next section, I will show in detail how these proposals derive the agreement patterns of attributive adjectives in Swedish. I will then show that they also account for adjectival inflection in Norwegian, Danish, and Dutch. Chapter five will then be devoted to show that my proposals also account for strong and weak adjectival inflection in German. German is different from languages like Swedish in that the weak adjectival inflection signals some number and case distinctions. I will argue that this is due to the fact that in some case the definite D in German is only partially deactivated, yielding only partial blocking of Indirect Agree.

4. The strong – weak distinction in Swedish

In this section, I will show in detail how my proposals about strong and weak adjectival inflection account for the inflection of Swedish attributive adjectives. This section is organized as follows. I will first determine the syntactic representation of the features that participate in adjectival agreement in Swedish. After that, I will discuss how my Indirect Agree account explains the strong inflection in Swedish. Finally, I will show how my account for the weak adjectival inflection derives the facts of Swedish weak inflection.

4.1. The syntactic representation of gender and number in Swedish

In section 2.1, I proposed that the syntactic representation of features depends on the morphological realization of feature interpretations in the way described in (21), repeated here in (59).

- (59) MORPHO-DRIVEN FEATURE REPRESENTATION
- If an interpretation of a particular feature is:
- a. **morphologically realized**, the interpretation is mapped onto a fully specified feature representation, i.e. an attribute-value pair.
 - b. **morphologically unrealized**, the interpretation is mapped onto an underspecified feature representation, i.e. onto an attribute.

As I showed in section 2.1, one of the consequences of morpho-driven feature representation is that it is possible that the syntactic representation of a particular feature displays cross-linguistic variation. In languages in which one of the feature interpretations is morphologically unrealized, the feature has a syntactic representation in which the attribute is interpretable without a value. In languages in which

all interpretations of the relevant feature are morphologically realized, the feature has a syntactic representation in which the attribute is always uninterpretable without a value. Above, I argued that this difference concerning the interpretability of the attribute has important consequences for Agree. Before analyzing strong and weak adjectival agreement in Swedish in terms of Agree, I will therefore determine the syntactic representations of the features involved in Swedish adjectival agreement.

As mentioned in the introduction, Swedish attributive adjectives inflect according to the paradigm given in (4) above, reproduced here in (60).

(60) ADJECTIVAL INFLECTION IN SWEDISH DPS

	SG, NON-NEUTER	SG, NEUTER	PL
Weak (definite DPs)	-a/-e ²⁷	-a/-e	-a/-e
Strong (indefinite & articleless DPs)	∅	-t	-a/-e

This paradigm reveals that two features participate in Swedish adjectival agreement: gender and number.²⁸ Let's first determine the way in which the Swedish number feature is syntactically represented. The 'plural' interpretation of this feature is morphologically marked on most nouns through means of a suffix, just as in English. This is shown in (61).

- (61) a. *två hund-ar* b. *två yrke-n*
 two dog-PL two job-PL
 'two dogs' 'two jobs'

Under morpho-driven feature representation, the morphological realization of a specific feature interpretation indicates that the syntactic representation of this interpretation consists of an attribute-value pair. Hence, 'plural' is syntactically represented in Swedish by an attribute-value pair consisting of the number attribute (#) and the plural value (pl), i.e. by [#: pl]. What about singular? Singular, unlike plural, is not morphologically realized on nouns. Put differently, there is no singular suffix in Swedish. For instance, the singular forms of the nouns in (61) consist of the nominal root without any suffix, as in (62).

- (62) a. *en hund* b. *ett yrke*
 a.NONNEUT dog a.NEUT job
 'a dog' 'a job'

²⁷ The choice between *-a* and *-e* is lexically determined by the adjective: some adjectives take *-a*, others *-e* (see Holmes & Hincliffe 1994).

²⁸ Although the adjectival inflection differs in definite DPs from that in indefinite DP, I do not consider definiteness to be a feature that participates in Swedish adjectival agreement. I will show below that the different adjectival inflection in definite and indefinite DPs is the result of independently motivated differences between definite and indefinite DPs and not of agreement in definiteness or indefiniteness.

Although it is not realized on nouns, singular is morphologically realized on other elements. Consider for instance the different forms of the Swedish freestanding definite article in the table in (63).²⁹

(63) THE FREESTANDING DEFINITE ARTICLE IN SWEDISH

NEUTER SINGULAR	NON-NEUTER SINGULAR	PLURAL
<i>det</i>	<i>den</i>	<i>de</i>

Given that they only occur with nouns that are interpreted as singular, the *det* and *den* forms of the freestanding definite article are marked for singular. Hence, singular is morphologically realized on some elements in Swedish. Under my proposal in (59), singular should therefore be syntactically represented through means of an attribute-value pair.³⁰ I take this pair to be [#: sg], where # stands for the number attribute and *sg* for the singular value. In Swedish both singular and plural are thus each mapped onto attribute-value pairs, as in (64).

(64) NUMBER IN SWEDISH

Interpretation	Syntactic Representation
'singular'	[#:sg]
'plural'	[#:pl]

In addition to singular, the *det* and *den* forms of the freestanding definite article also morphologically realize the different interpretations³¹ of the gender feature. As can be seen in the table in (63), *det* only occurs with neuter nouns. It therefore realizes neuter. *Den*, on the other hand, only occurs with non-neuter nouns. As such, it morphologically realizes non-neuter gender. Because they are each morphologically realized, neuter and non-neuter each correspond to an attribute-value pair in syntax (cf. (59a)). I take the gender attribute to be *Gen*. In the case of neuter, this attribute is combined with the neuter value *neut*. In case of non-neuter, it is combined with the non-neuter value *nonneut*. The syntactic representation of gender in Swedish is thus as in (65).

(65) GENDER IN SWEDISH

Interpretation	Syntactic Representation
'neuter'	[Gen: neut]
'non-neuter'	[Gen: nonneut]

²⁹ The freestanding definite article occurs in definite DPs that contain adjectives together with a definiteness suffix on the noun (see chapter 2). The argument developed in the main text could also be made on the basis of the definiteness suffix or the indefinite article.

³⁰ Note that I take the fact that singular is morphologically realized on some elements to be evidence for representing singular number in Swedish always as an attribute-value pair, not only on those elements on which it is morphologically realized.

³¹ It might appear strange to talk about the different interpretations of gender. However, I assume along the lines of Picallo (2005) that gender has some interpretational component in the form of categorizing entities/objects. I will come back to this issue in chapter 6.

In (64) and (65), all interpretations are mapped onto attribute-value pairs. This has as a consequence that both the gender attribute (*Gen*) and the number attribute (#) are uninterpretable in case they occur without a value. In the following sections, this will play an important role in my analysis of agreement on Swedish attributive adjectives.³²

After having determined the syntactic representation of the features involved in Swedish adjectival agreement, I will now turn to strong adjectival inflection in Swedish.

4.2. Swedish strong adjectival inflection

As mentioned above, strong adjectival inflection in Swedish signals gender and number agreement with the noun (cf. the table in 66). It occurs on adjectives in DPs without an article or on those in DPs introduced by the indefinite article. This was shown in (53b/c) above, repeated here in (67a-b).

(66) STRONG ADJECTIVAL INFLECTION IN SWEDISH

FEATURES NOUN	NEUTER, SG	NON-NEUTER, SG	PL
ADJECTIVAL ENDING	-t	-∅	-a/-e

- (67) a. *ett stor-t hus* INDEFINITE: STRONG
 a.NEUTER big-NEUTER.SG house
 'a big house'
- b. *vacker-t väder* ARTICLELESS: STRONG
 beautiful-NEUTER weather
 'beautiful weather'

In section 3, I proposed to analyze the agreement signaled by the strong adjectival inflection as the result of Indirect Agree. The case assigner of the DP in which the adjective is contained first enters into an Agree-relation with the adjective and then the noun. In that way, feature sharing between the noun and the adjective is licensed, even though they cannot enter into a (direct) Agree-relation themselves. This feature

³² As noted in the main text, there is positive morphological evidence for the claim that *det* realizes singular and neuter and *den* singular and non-neuter. This evidence is simply that *det* only occurs with neuter singular nouns and that *den* only occurs with non-neuter nouns. Theoretically speaking, it would be possible that *det* and *den* do not realize all these interpretations, but only a subset of them. For instance, one might consider a scenario under which *det* realizes neuter and *den* non-neuter, but both elements do not realize singular. Another possible scenario would be that both elements realize singular, but only one of them gender. The problem for scenarios like these is that it is impossible to determine on the basis of the distribution of *det* and *den* (see the table in (63)), which of feature interpretations (singular, neuter, non-neuter) are realized and which are not. Put differently, although theoretically possible, these scenarios lack positive evidence. The L1 learner does therefore not consider them.

sharing is then spelled out on the adjective as the strong adjectival inflection. In this section, I will show in detail how this account explains the strong adjectival inflection in Swedish. I will first discuss strong inflection on adjectives in DPs without an article, like the one in (67b). I will then show that my Indirect Agree proposal also accounts for strong inflection on adjectives in DPs that are introduced by the indefinite article, like the one in (67a).

4.2.1. Strong adjectival inflection in articleless DPs

In order to show how the Indirect Agree account explains the presence of strong inflection on attributive adjectives in DPs that are not introduced by an article, I will discuss in detail how the strong adjectival inflection in (68) is licensed. I will do this by going step by step through the relevant parts of the syntactic and morphological derivation of (68).

(68) [*vacker-t* *väder*] *är* *viktigt*
 beautiful-NEUTER.STRONG weather BE.PRESENT important
 ‘beautiful weather is important’

In chapter 2, I adopted the distributed morphology model of the grammar (Halle & Marantz 1993). In this framework, narrow syntax operates on morphosyntactic features. Phonological content is only associated with these feature bundles in the postsyntactic morphological part of the derivation. I will continue to use this model of grammar in the discussion that follows. Note that I argued in section 4.1 that the feature interpretations relevant for adjectival agreement in Swedish (neuter/non-neuter for gender and singular/plural for number) were all syntactically represented by fully specified feature representations, i.e. attribute-value pairs.

4.2.1.1 The syntactic derivation of Swedish articleless DPs

In order to consider in detail the licensing of the strong adjectival inflection on the adjective in (68), I first need to briefly discuss the general characteristics of the syntactic derivation of Swedish articleless DPs containing adjectives. The null hypothesis is that this derivation only minimally differs from that of other DPs containing adjectives. In chapter 2, I argued that Swedish definite DPs that contain adjectives have a syntactic derivation in which D undergoes internal merge. This instance of internal merge is triggered as a result of a type mismatch created by adjunction of the adjective to DP. Adopting the null hypothesis, I argue that this is also the case for DPs without an article. I thus propose that adjectives in articleless DPs are also adjoined to DP and that their adjunction triggers internal merge of D, as in (69).

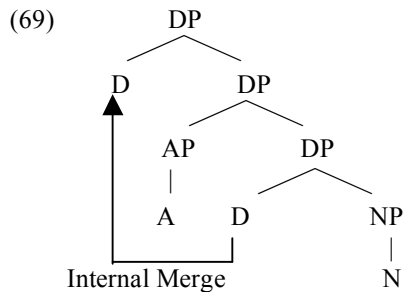

Despite being largely similar to the derivation of definite DPs, the derivation of articleless DPs is different in a number of aspects. Firstly, the D of articleless DPs is null, unlike the definite D, which receives morphological realization in the form of the definite article. Put differently, there are no vocabulary items in Swedish that spell out the feature content of D in DPs like that in (68). The second difference concerns the probehood of D. As argued in section 3.2, definite Ds are Probes, since they display agreement morphology. Given that they are not morphologically realized, Ds in articleless DPs do also not display agreement. Hence, there is no indication that D in articleless DPs is a Probe. I therefore conclude that this D is not a Probe, unlike its definite counterpart.³³ Keeping these considerations in mind, let's now examine in detail how my Indirect Agree account explains the presence of strong inflection in (68).

4.2.1.2 Illustration of the proposal for Swedish articleless DPs

The first step in the derivation of (68) is to merge D and N. N is specified as a singular neuter noun. Under the syntactic representation of gender and number in Swedish that I determined in section 4.1 above, this means that it has a number feature specified as singular and a gender feature that is specified as neuter. As argued above, the null D does not have any features that are relevant for the licensing of adjectival agreement.³⁴ Crucially, it is not a gender and number Probe, unlike its definite counterpart. Merging D and N, as in (70) therefore does not trigger any Agree-relations.

³³ Since D is not a Probe, it does not play a role in the licensing of strong adjectival inflection in articleless DPs. My account of the licensing of strong adjectival inflection is therefore also compatible with a structure of Swedish articleless DPs that lack D altogether.

David Pesetsky (personal communication) suggests an alternative analysis of the syntactic derivation of articleless DPs and DPs introduced by the indefinite article. He suggests that the null D in these DPs does not raise, since indefinite DPs are of type <e,t> and hence no type mismatch is triggered. This alternative analysis articleless/indefinite DPs is also compatible with my account of strong adjectival agreement, since the D does not play a role in the licensing of strong adjectival inflection under my account.

³⁴ The null D probably have semantic feature that give the articleless DPs their readings. This is, however, not crucial for the present discussion.

(70) STEP #1: MERGE (D,N)

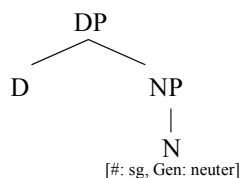

The second step in the derivation is to merge A as an adjunct to the already formed DP (see chapter 2 and the discussion above). This has the result in (71).

(71) STEP #2: MERGE (A,DP)

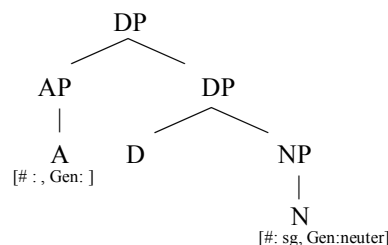

Contrary to D, A is a gender and number Probe. Under the view of Probes introduced in section 2.2 above, this means that it has underspecified number and gender features. A will try to specify these features by looking for a Goal. Given the dominance requirement of Agree, there is however no suitable Goal in A's search domain (see chapter 3 and section 3.1 of this chapter).³⁵ In (71), there is no element that is dominated by A that has gender and number features. Crucially, A does not dominate N, which has the required features, nor does a projection of A. The derivation will thus continue without A establishing an Agree relation.

The next step in the derivation is to internally merge D, as in (72). As discussed above, this step is triggered, just like in definite DPs, by the adjunction of the adjective to DP.

³⁵ Note that this reasoning crucially assumes that DPs contained in adjectival complements are not accessible as a Goal for the adjective. This might be because this complement is a phase, or that these DPs contained in these complements are deactivated as a Goal because they are already assigned case (see Chomsky 2001 for the deactivation of Goals).

(72) STEP #3: INTERNAL MERGE OF D

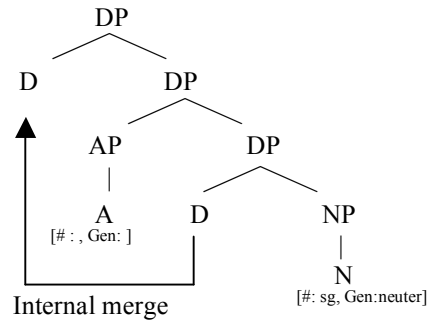

Since it is an identical copy of the lower D, the higher D-copy is not a Probe. Hence, no new Agree relations are established as a result of this step.

The derivation then continues until the case assigner is merged. As I claimed in section 3.1, the case assigner is the element that licenses feature sharing via Indirect Agree. I adopt here Chomsky (2001) proposal on case licensing. According to Chomsky, any case assigning head is also a Probe for phi-features. As a Probe, the case assigner enters into an Agree relation with a suitable Goal. As a by-product of this Agree-relation, the case feature of the case assigner is associated with the Goal. Although I claim that Agree triggered by case assigners plays an important role in the licensing of strong adjectival inflection in Swedish, the actual case feature that is assigned does not. Swedish does not have morphological case marking. It only has abstract case. Put differently, the case features that are assigned under Agree by case assigners do not receive morphological realization. Since they are irrelevant for morphology, I will omit from the following discussion the case features that are assigned by the case assigner. I will come back to the assignment of case features in chapter 5, in which it will play an important role in my discussion of German strong and weak adjectival inflection.

In the case of the subject DP in (68), the case assigner is T (cf. Chomsky 2001). Under Chomsky's (2001) view of case licensing, T is a Probe and has a nominative case feature. I propose here that the Swedish finite T is at least a Probe for gender and number.³⁶ Under the view of probehood advocated in section 2.2 of this chapter, T has therefore underspecified gender and number features, while it has a case feature that is specified as nominative. This is shown in (73).

³⁶ T might also be a Probe for other features, like for instance Person. However, I will abstract away from this possibility. Only gender and number are relevant for Swedish adjectival inflection. Agree for other features, like person, is therefore irrelevant for the present discussion.

(73)

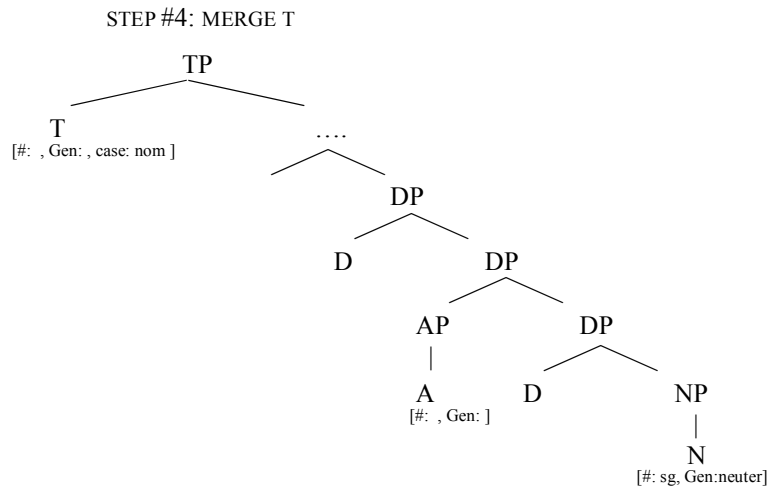

Because of its probehood, T will scan its search domain for any element with gender and number features. The first element that T finds in its search domain and that has these features is A. The gender and number features on A are underspecified, A being a Probe that failed to establish an Agree relation on its own earlier on in the derivation. However, this underspecification of features does not render A unsuitable as a Goal, because Agree on the feature sharing view can target elements with underspecified features as a Goal (see section 2.2). Agree is therefore established between T and A. This Agree relation is indicated in (74) as *Agree 1*.

(74)

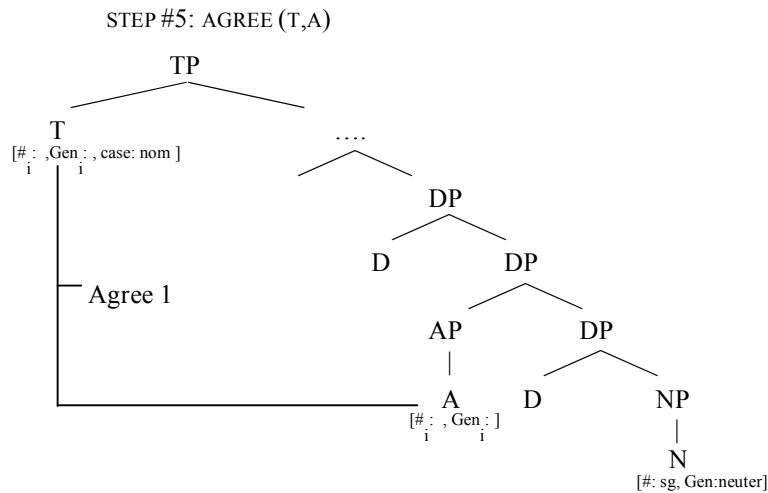

Agree 1 results in the sharing of A's underspecified gender and number features between T and A. This sharing is indicated in (74) through means of the *i*-indices.

Agree between T and A does not associate T with fully specified gender and number features. For this reason, T is not deactivated as a gender and number Probe. It will thus continue to search for elements with gender and number features. The next element T finds in its search domain that has these features is N. T will therefore enter into an Agree-relation with N. As a result of this instance of Agree (*Agree 2* in (75)), the gender and number features T is associated with are replaced through means of feature sharing with those of N. However, as a result of *Agree 1* in (74), T already shares gender and number features with A. Therefore, replacing the gender and number features of T automatically entails replacing these features on A as well. Hence, *Agree 2* does not only associate T with the gender and number features of N, but also A. In the present example, this results in both T and A to be associated with singular number and neuter gender, as in (75).

(75) STEP #6: AGREE (T,N)

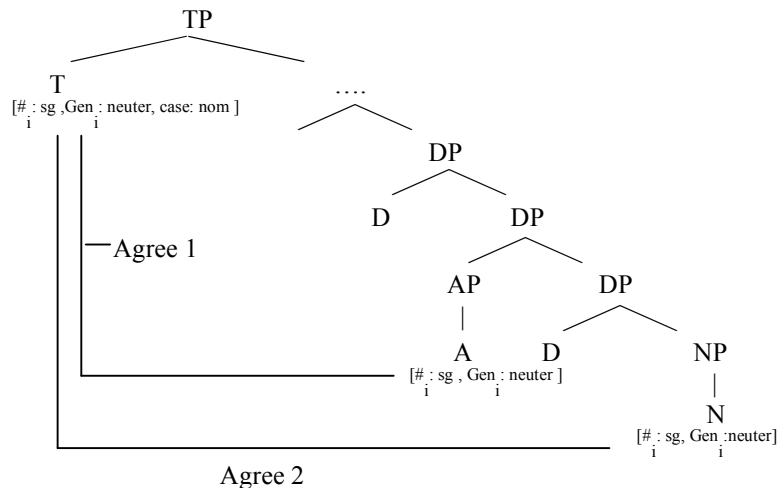

Since *Agree 2* associates T with fully specified gender and number features, T is deactivated as a Probe.

In this way, A gets to share gender and number features with N without entering into a direct Agree relation with N. In section 3.1, I called this way of licensing feature sharing without a direct Agree relation *Indirect Agree*. In the present example, the case-assigner T licenses Indirect Agree between A and N by first entering into Agree with A and then with N.

T entering into an Agree relation with N is the last step of the syntactic part of the derivation of (68) that is relevant for the licensing of the adjectival inflection. After the syntactic derivation is completed, the derivation is handed over to both the CI- and SM-interfaces. At the CI-interface, the $[\#: sg]$ and $[Gen: neuter]$ features that are shared between T, A, and N are only interpretable on N. On T and A, the other two elements they are associated with, these features are not interpreted. In section 2.3 of this chapter, I proposed that the interpretation of features at the SM-interface

depends on interpretation at the CI-interface in the manner described in (42), repeated here in (76).

- (76) CI-DEPENDENT SM-INTERPRETATION
 A feature is interpreted at the SM-interface in all the positions it is associated with if it is CI-interpretable in one of these positions. In case it is not associated with a position in which it is CI-interpretable, the feature is ignored at the SM-interface in all the positions it is associated with.

Under CI-dependent SM-interpretation, the [#:sg] and [Gen: neuter] features A is associated with are interpretable on A at the SM-interface. A shares these features with N and T. Given that they are CI-interpretable at N, these features are also interpretable at A at the SM-interface. Hence, A enters the SM-components of the grammar with the feature specification in (77).

- (77) SM-INTERPRETATION
 A-[#:sg, Gen:neuter]

In the SM-components of the grammar, the morphosyntactic feature bundles are first matched with phonological content. As described in chapter 2, this happens at Vocabulary Insertion. In the case under investigation, *stor* is inserted for A. As for the gender and number features on A, I propose that the VI-rule in (78) is responsible for spelling out these features as the strong inflectional *t*-ending on the adjective.

- (78) VI-RULE A:
 A-[#:sg, gen: neuter] → A-*t*

Vocabulary Insertion for A in (68) thus can be summarized as in (79).

- (79) STEP #7: VOCABULARY INSERTION
 A-[#:sg, gen:neuter] → *vacker-t*

Vocabulary Insertion is the last relevant step in the licensing of the adjectival inflection in (68). This concludes my detailed illustration of how the indirect Agree proposal accounts for the licensing of strong adjectival inflection in Swedish DPs without an article.

4.2.1.3 VI-insertion rules for Swedish strong adjectival inflection

Under the indirect Agree proposal, adjectives in Swedish DPs without an article leave the syntactic component of the grammar with the same gender and number specification as N. This gender and number specification is subsequently spelled out as the strong adjectival inflection. In the distributed morphology model of the grammar I adopt, this spell-out takes place via Vocabulary Insertion (VI-) rules.

These rules apply in the post-syntactic morphological component at the point of Vocabulary Insertion (see chapter 2). In addition to the rule in (78), repeated as rule A in (80a), I propose two other rules that spell out gender and number feature specifications on A as strong adjectival inflection: rule B in (80b), which spells out singular and non-neuter gender and rule C in (80c), which is the elsewhere rule.

- (80) VI-INSERTION RULES FOR ADJECTIVAL INFLECTION IN SWEDISH:
- a. RULE A: A-[Gen:neuter, #: sg] → A-*t*
 - b. RULE B: A-[Gen:non-neuter, #: sg] → A-∅
 - c. RULE C: A-[∅] → A-*a*

Swedish nouns are specified for one of two numbers, singular and plural, and for one of two genders, neuter and non-neuter. There are thus four possible gender and number specifications for N in Swedish. Under my analysis, the gender and number specification of A is the same as that of N at the outcome of Narrow Syntax. There are thus also four different gender and number specifications for A in Swedish articleless DPs at the end of the syntactic derivation. These four different specifications are listed in the second column in the table in (81), using the feature representation that I determined in section 4.1 of this chapter. The three rules in (80) map these specifications onto a particular ending in accordance with the subset principle (Halle 1997: 128). The subset principle states that the more specific VI-rule applies if the structural condition on two or more rules is met. Hence, rule A (or B) will take precedence over rule C in case both rules could in theory be applied. For instance, the inflection will be spelled out according to VI-rule A in singular neuter indefinites, i.e. as *-t*, and not according to less specific rule C as *-a*. The third column of the table in (81) indicates which VI-rule applies in case of each of the four possible gender and number specifications. The result of the application of each VI-rule is given in the fourth column of this table. In (82), each of the four possible gender and number specification is illustrated.

- (81) VI-INSERTION FOR STRONG ADJECTIVAL INFLECTION IN SWEDISH

Description	Features on A	VI-rule	Inflectional suffix	Example
SG, NEUTER	[#:sg, Gen:neuter]	A	- <i>t</i>	(82a)
SG, NON-NEUTER	[#:sg, Gen: non-neuter]	B	-∅	(82b)
PL, NEUTER	[#:pl, Gen: neuter]	C	- <i>a</i>	(82c)
PL, NON-NEUTER	[#:pl, Gen:non-neuter]	C	- <i>a</i>	(82d)

- (82) a. *vacker-t* *väder* NEUTER, SG
 beautiful-NEUTER weather
 ‘beautiful weather’

b.	<i>god-∅</i> good-NONNEUTER 'good food'	<i>mat</i> food	NON-NEUTER, SG
c.	<i>stor-a</i> big-PL 'big houses'	<i>hus-∅</i> house-PL	NEUTER, PL
d.	<i>ung-a</i> young-PL 'young girls'	<i>flick-or</i> girl-PL	NON-NEUTER, PL

Under the Indirect Agree proposal of strong inflection, the syntactic component ensures that adjectives in articleless DPs bear the same gender and number specification as N. The morphological component subsequently ensures that this specification is spelled out as strong adjectival inflection by means of the VI-rules in (81).

4.2.2. Strong adjectival inflection in DPs with an indefinite article

As mentioned above, strong inflection does not only occur in Swedish on adjectives in DPs without an article, but also on adjectives in DPs that are introduced by the indefinite article, like in (67a) above, repeated below in (83).

(83)	<i>ett</i> a.NEUTER 'a big house'	<i>stor-t</i> big-NEUTER.SG	<i>hus</i> house	INDEFINITE: STRONG
------	-----------------------------------------	--------------------------------	---------------------	--------------------

My proposal that strong adjectival inflection is the result of Indirect Agree also accounts for this instance of strong adjectival inflection. In order to see how, we need to take a closer look at the Swedish indefinite article.

In general, indefinite articles are analyzed as instances of D (see among others Abney 1987). However, such an analysis cannot account for the presence of strong inflection on adjectives in DPs introduced by the indefinite article. The null hypothesis is that Swedish indefinite DPs are only minimally different from Swedish definite DPs. It is therefore plausible to assume that adjectives in indefinite DPs are adjoined to DP and trigger internal merge of D, just like their counterparts in definite DPs (see chapter 2).³⁷ In section 3.2, I argued that internal merge of D in definite DPs blocks the licensing of strong adjectival inflection. The definite D has

³⁷ As one can see in (83), there is no doubling of the indefinite article in Swedish in the presence of an adjective. As discussed in chapter 2, the definite article is doubled in that case. Under an analysis in which the indefinite article is an instance of D, this lack of doubling could be attributed to status of the indefinite article as a free morpheme. Contrary to the definite article, the indefinite article would then be fully visible to Chain Reduction, bleeding a double spell out. This would make the absence of article doubling with the indefinite article similar to the absence of doubling with Swedish *denna*-demonstratives or the German definite article.

Below, I will however adopt an analysis of the indefinite article in which it is a numeral not an instance of D. Given that there is only one position for numerals in the nominal domain, the absence of doubling of the indefinite article receives a straightforward explanation under that proposal.

probing features that are deactivated prior to internal merge. This causes the D-copy created by internal merge to be a deactivated Probe. As a deactivated Probe, it intervenes between the adjective and other Probes, thus blocking the licensing of the strong adjectival inflection via Indirect Agree (see for more details sections 3.2 and 4.3 of this chapter). Like the definite article, the indefinite article agrees with the noun for gender. This agreement is illustrated in the table in (84).³⁸

(84) SWEDISH INDEFINITE ARTICLES

NEUTER SG	NON-NEUTER SG
Ett	en

If the indefinite article were the spell out of D, the indefinite D would be a Probe like the definite D. Agree would then deactivate the indefinite D as a Probe prior to internal merge. As a consequence, the higher D-copy would be a deactivated Probe in indefinite DPs like in definite DPs. Since this is the cause for the absence of strong adjectival inflection in definite DPs, this predicts that strong adjectival inflection should also be absent in indefinite DPs. This prediction is not borne out: adjectives in DPs introduced by the indefinite article, like the one in (83), take strong adjectival inflection. Under the analysis pursued here, the Swedish indefinite article can therefore not be the spell out of D. Instead, I propose an alternative analysis of the Swedish indefinite article in which the indefinite article has the same syntactic status as a numeral (see Perlmutter (1970) for similar claims about the English indefinite article³⁹).

In many languages, the form of the indefinite article is identical to that of the numeral *one*, as is shown in (85) for French.

(85) *une* *voiture* [French]
 a.FEM/one.FEM car
 ‘a/one car’

This is also the case in Swedish. In Swedish, *en* and *ett* are used as the indefinite article as well as the numeral *one* (Holmes & Hincliffe (1994: 228-229)). In (86a-b), *en* and *ett* are for instance ambiguous between an indefinite article reading and an interpretation as the numeral *one*.

(86) a. *en* *buss*
 one/a.SG.NON-NEUTER bus
 ‘one/a bus’

³⁸ Note that there is no overt plural indefinite article in Swedish, as can be seen in (i).

(i) a. *ung-a* *flick-or* NON-NEUTER, PL, INDEF
 young-PL girl-PL
 ‘two young girls’
 b. *stor-a* *hus* NEUTER, PL, INDEF
 big-PL house
 ‘two big houses’

³⁹ Perlmutter (1970) proposes that the English indefinite article *a(n)* is derived from the numeral *one*.

- b. *ett* *tåg*
 one/a.SG.NEUTER day
 ‘one/a day’
- c. *ett, två, tre...*
 one, two, three
 ‘one, two three’
- (Holmes & Hincliffe 1994: 229)

This identity in form suggests an alternative syntactic analysis of the Swedish indefinite article. I claim that the indefinite article is syntactically one and the same element as the numeral *one*.⁴⁰ It is thus syntactically represented as a numeral, instead of being an instance of D. Note that numerals are themselves not instances of D, since D can co-occur with numerals. This is shown by the co-occurrence of the definite article and the numeral *två* ‘two’ in (87).

- (87) *de två hus-en*
 the.PL two house-DEF.PL
 ‘the two houses’

As pointed out to me by Anders Holmberg (p.c.), this also holds for the numeral *one*. This is shown in (88). Note that the numeral *one*, like adjectives, takes weak inflection in definite DPs.⁴¹

- (88) a. *det en-a hus-et*
 the.NEUT one-WEAK house-DEF.NEUT
 ‘the one house’
- b. *den en-a bil-en*
 the.NONNEUT one-WEAK car-DEF.NONNEUT
 ‘the one car’
- Anders Holmberg (p.c.)

Analyzing the Swedish indefinite article as a numeral has consequences for the derivation of DPs introduced by the indefinite article. In order to appreciate this, consider first the derivation I proposed in chapter 2 for definite DPs that contain a numeral.

As can be seen in (87) and (88), the presence of a numeral triggers doubling of the definite article in definite DPs. In chapter 2, I analyzed this doubling in the same way as double definiteness triggered by the adjective. Like the adjective, numerals are merged after D in definite DPs. This causes a type mismatch. This type

⁴⁰ Barbiers (2005: 168) claims for Dutch that there is partial identity between the feature content of the indefinite article and the numeral *one* in Dutch and several Dutch dialects. According to him, the numeral *one* is distinct from the indefinite article in that it has [focus]-feature. This is close to the view proposed here. Contrary to what is assumed here, Barbiers, however, takes the numeral *one* and the indefinite article instantiations of two different syntactic heads.

⁴¹ Below, I will propose that the inflection on the indefinite article/numeral *one* is licensed in exactly the same way as adjectival inflection. From that perspective, the presence of weak inflection on the numeral *one* in definite DPs is unsurprising.

mismatch is then resolved by internal merge of D. I illustrate this in (89). In what follows, I assume that *numerals* are adjuncts to DP just like adjectives.⁴²

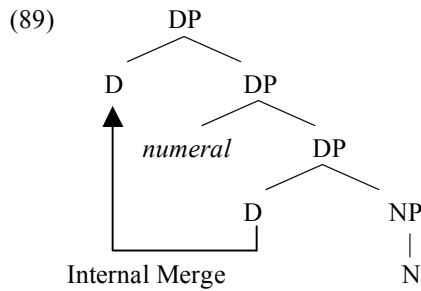

In definite DPs, the two copies that are the result of internal merge are then both spelled out, resulting in the doubling of the definite article.

Adopting the null hypothesis that indefinite DPs are only minimally different with respect to this, I propose that numerals in indefinite DPs also trigger internal merge of D. There is, however, one crucial difference between definite and indefinite DPs. The indefinite D is null, unlike the definite D. For the plural indefinite DP *två hus* ‘two houses’, the numeral would thus be spelled out in the morphological component as *två* ‘two’, while D does not receive morphological realization. On the analysis that the Swedish indefinite article is a numeral, DPs introduced by the indefinite article, like *ett hus*, would also involve internal merge of the null D as in (89) with the indefinite article as the numeral.

There is, however, one minor difference between ordinary numerals and the indefinite article/the numeral *one*. The indefinite article/numeral *one* displays agreement with the noun (see the table in (84)), while the other numerals are invariant. The agreement on the indefinite article/numeral *one* is licensed in exactly the same way as the strong adjectival inflection in DPs without an article, i.e. via Indirect Agree. As an adjunct, the indefinite article/numeral *one* cannot establish a direct Agree relation with N, because of the dominance requirement. It will however end up sharing features with the noun via Indirect Agree because of the Agree-relations established by the case-assigner of the DP in question. This case assigner first enters into an Agree-relation with the indefinite article/numeral *one* and then with N. This is shown in (90), in which X represents the case assigner of the DP in question.

⁴² The analysis I will present below will also hold if numerals are in specifiers of dedicated functional projection, as for instance in Julien (2005), as long as they are merged later than (the lower) D.

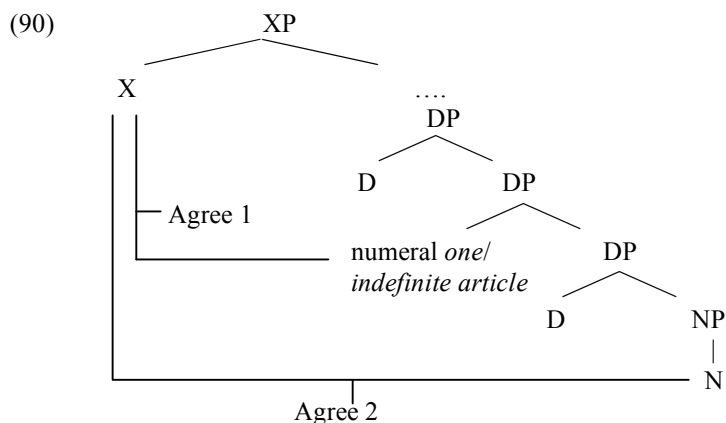

Let's now consider DPs that are introduced by the indefinite article and that contain an adjective, like the one in (83), repeated here in (91).

- (91) *ett* *stor-t* *hus* INDEFINITE: STRONG
 a.NEUTER big-NEUTER.SG house
 'a big house'

The derivation of (91) combines the derivation of DPs that are introduced by the indefinite article but do not contain an adjective (see above) with that of articleless DPs that contain an adjective (see section 4.2.1). First, the adjective is adjoined to DP. The type mismatch that is the result of this adjunction triggers internal merge of the null D (*internal merge 1* in (92)) just as in the case of articleless DPs. Then, the indefinite article is merged as an adjunct to the DP that has just been constructed.

⁴³This creates a second type mismatch. This mismatch is resolved by a second instance of internal merge, (*internal merge 2* in (92)), as in (89) above.

⁴³ Internal merge of D precedes the adjunction of the numeral, because the type mismatch created by adjoining the adjective needs to be resolved immediately, as a result of the Earliness Principle (see chapter 3).

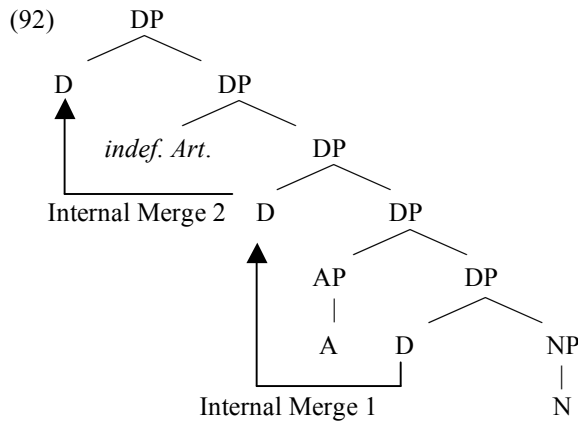

As explained above, both the indefinite article and the adjective are Probes that cannot enter into a direct Agree relation with N because of the dominance requirement. Hence, both the indefinite article and the adjective still carry their underspecified probing features when the case-assigner is merged, X in (93). The probing gender and number features on the case-assigner will first enter into an Agree-relation with the indefinite article, the first element in its search domain with the relevant gender and number features. This is indicated in (93) as *Agree 1*. Given that the indefinite article has only underspecified gender and number features by virtue of being a Probe for these features, Agree results in the sharing of the underspecified gender and number features between the case assigner and the indefinite article. However, this sharing does not deactivate the case assigner as a Probe, the shared features being underspecified. The case assigner therefore continues to scan its search domain for elements with gender and number features. The next element it will find with these features is the adjective. The adjective has underspecified instances of these features because of its own probeness. Because of these features, the case-assigner enters into an Agree-relation with the adjective, *Agree 2* in (93). This leads to the sharing of underspecified features between the adjective, the case-assigner and, by virtue of *Agree 1*, the indefinite article. Again, Agree does not deactivate the case assigner as a Probe, since the features that are shared are still underspecified. The next element the case assigner finds with gender and number features is the noun. Agree is established between the case assigner and the noun, *Agree 3* in (93). This instance of Agree replaces the underspecified features of the case-assigner with the fully specified gender and number features of the noun via feature sharing. By virtue of *Agree 1* and *Agree 2*, the underspecified features of the case assigner were also associated with the indefinite article and the adjective. Hence, *Agree 3* does not only associate the case assigner with the gender and number features, but also the adjective and the indefinite article. This is shown in (93).

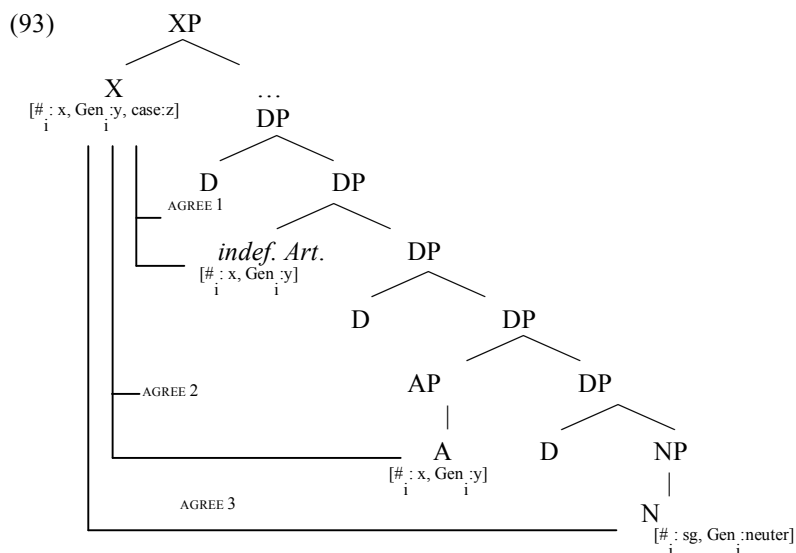

In this way, Swedish adjectives in DPs that are introduced by the indefinite article get to share gender and number features with the Noun as a result of the Agree relations established by the case assigner of DP. This licensing via Indirect Agree is almost identical to that in articleless DPs. The only difference is that the Agree relations established by the case assigner do not only license Indirect Agree between the adjective and the noun, but also between the noun and the indefinite article. Like in articleless DPs, the sharing of gender and number features between the adjective and the noun are spelled out on the adjective in the morphological component as strong adjectival inflection by the VI-rules given in (80) above.

Strong adjectival inflection on multiple adjectives is licensed in the same way. If more than one adjective modifies the noun in articleless or indefinite DPs, all adjectives receive strong inflection. This is shown in (94a) for articleless DPs and in (94b) for DPs introduced by the indefinite article.

- (94) a. *vacker-t* *solig-t* *väder*
 beautiful-NEUTER.SG sunny-NEUTER.SG weather
 ‘beautiful sunny weather’
- b. *ett* *stor-t* *gammal-t* *hus*
 a.NEUTER big-NEUTER.SG old-NEUTER.SG house
 ‘a big old house’

Under my proposal that strong adjectival inflection is the result of Indirect Agree, this observation is straightforwardly accounted for. After the case assigner has established Agree with the first adjective, the next Goal in its search domain is not the noun, but the second adjective. Before entering into an Agree relation with the noun, the case assigner will therefore first enter into Agree with this second adjective. It will also do so with any other adjective present, before it enters into an Agree relation with the noun. Hence, the case assigner shares features with all

adjectives present before entering into an Agree-relation with the noun. Agree with the noun then associates all adjectives to the gender and number features of the noun. In this way, strong adjectival inflection is licensed on all adjectives in a DP as a result of Indirect Agree.

After having shown that my Indirect Agree proposal for strong inflection accounts for strong adjectival inflection, I will now discuss in detail how my proposal for weak adjectival inflection accounts for Swedish weak adjectival inflection.

4.3. Swedish weak adjectival inflection

In section 3.2, I proposed that the lack of agreement displayed by adjectives carrying weak adjectival inflection is due to Indirect Agree between the adjective and the noun being blocked in definite DPs. In that section, I formulated the proposal in general terms. In this section, I will now become more concrete and show in detail how the proposal accounts for the weak adjectival inflection in Swedish.

4.3.1. Illustration of the proposal

Recall that the weak adjectival inflection in Swedish does not express any gender and number agreement with the noun (see section 1). No matter the gender and number features of the noun, adjectives in definite DPs take the same ending, as was illustrated in (3), repeated here in (95).

(95)	a.	<i>den</i> the.NONNEUTER 'the young girl'	<i>ung-a</i> young-WEAK	<i>flicka-n</i> girl-DEF.NONNEUTER	NON-NTR, SG, DEF
	b.	<i>det</i> the.NEUTER 'the big house'	<i>stor-a</i> big-WEAK	<i>hus-et</i> house-DEF.NEUTER	NEUTER, SG, DEF
	c.	<i>de</i> the.PL 'the big houses'	<i>stor-a</i> big-WEAK	<i>hus-en</i> house-DEF.PL	NEUTER, PL, DEF
	d.	<i>de</i> the.PL 'the young girls'	<i>ung-a</i> young-WEAK	<i>flick-or-na</i> girl-PL-DEF	NON-NTR, PL, DEF

In order to show the way in which my proposal about weak adjectival inflection accounts for the absence of agreement in the weak inflection, I will discuss in detail how adjectival inflection is licensed in the definite DP in (95b), *det stora huset* 'the big house'. As with my discussion of strong adjectival inflection in section 4.2, I provide all the steps of the derivation that are relevant for the licensing of the adjectival inflection.

The first step in the derivation of the DP in (95b) is to merge D with N, just like in the derivation of indefinite DPs (see section 4.2.1.3 above). This results in the structure in (96).

(96) STEP #1: MERGE (D,N)

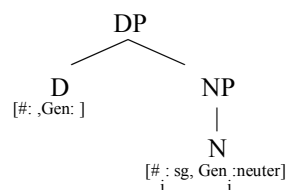

Swedish definite articles inflect for gender and number (see (95)). This shows that the definite D starts out the derivation as a gender and number Probe, unlike D in DPs with the indefinite article or without any articles. N constitutes a suitable Goal for D, because of its gender and number features. Moreover, D dominates N, as a result of merge and label-sharing (projection). The dominance requirement on Agree is thus satisfied. As a consequence, Agree between D and N is established, as in (97).

(97) STEP #2: AGREE (D,N) (for both # and gen)

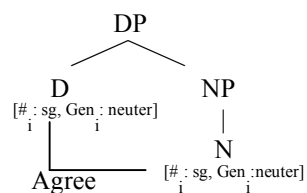

As a result of this second step, D is associated with the gender and number specification on N through feature sharing. This sharing is indicated in (97) through means of the *i*-indices.

The next step is to merge A as an adjunct to DP (see chapter 2). This step has as its outcome the structure in (98).

(98) STEP #3: MERGE (A, DP)

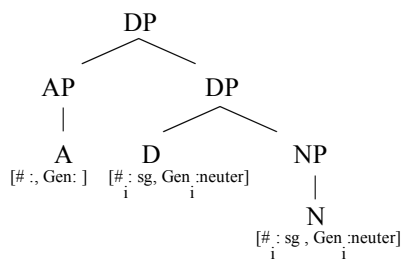

Despite being a gender and number Probe, A cannot establish Agree. A, or any of its projections, fail to dominate an element with gender and number features. There is therefore no suitable Goal in the search domain of A. However, merging A as an adjunct to DP results in A being dominated by a node that is part of the projection of D (i.e. by a DP-node). Under the label-sharing view of projection (see chapter 3), this node shares its label with the other nodes of the DP-projection. This label originally contained probing features. However, no Agree is triggered in this case, since these probing features were already deactivated by Agree in step 2.

The next step in the derivation is internal merge of D, which is triggered by the type mismatch caused by the adjunction of the adjective, (99) (see chapter 2).

(99) STEP #4: INTERNAL MERGE OF D

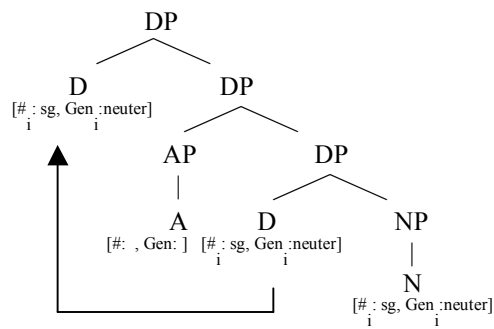

The internally merged D in (99) is an exact copy of the lower D. The lower D is associated with the gender and number specification of N via Agree in (97). Given the identity of the two copies, the higher D-copy is also associated with this specification. It therefore is a deactivated gender and number Probe, just like the lower D. As a consequence, there are no new Agree relations established. The derivation will therefore continue without A participating in any Agree relation.

The next step in the derivation is to merge a DP-external case-assigning gender and number Probe. The closest Goal for such a case assigner is the higher D-copy. Agree is therefore established between these two elements. The higher D-copy is associated by feature sharing with the fully specified gender and number features of N by virtue of Agree in step 2 and Internal Merge in step 4. Hence, Agree between the case assigner and the higher D-copy associates the case-assigner with the fully specified features of N. This is shown in (100), in which X represents the case assigner (i.e. T, v, P).

(100) STEP #5: MERGE CASE ASSIGNER + AGREE (CASE ASSIGNER, D)

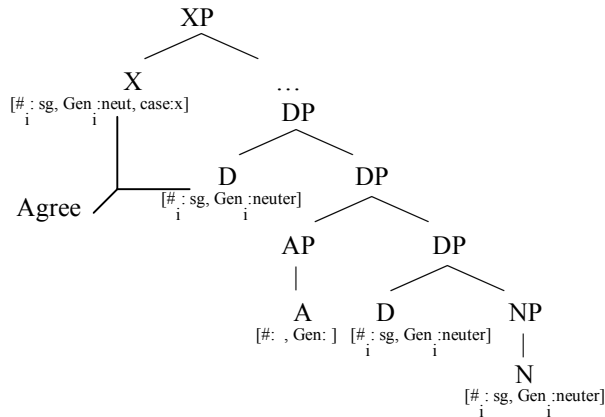

Agree in (100) deactivates the case assigner in the Probe, since it associates the case assigner with fully specified features. The case assigner will therefore not continue to search for a Probe. Hence, it does not enter into an Agree relation with A. Put differently, Agree between the case assigner and A is blocked due to intervention by the higher D-copy. Since it does not enter into Agree with A, the case assigner of Swedish definite DPs does not license feature sharing between A and N via Indirect Agree, unlike in the licensing of strong adjectival inflection (see section 4.2). Hence, A will reach the interfaces without participating in any Agree relations.

Subsequently, the syntactic derivation is shipped off to the interfaces. At the SM-interface, I proposed that interpretation is constrained by the condition in (42), repeated here in (101).

(101) CI-DEPENDENT SM-INTERPRETATION

A feature is interpreted at the SM-interface in all the positions it is associated with if it is CI-interpretable in one of these positions. In case it is not associated with a position in which it is CI-interpretable, the feature is ignored at the SM-interface in all the positions it is associated with.

Because it does not participate in any Agree relations, A leaves the syntactic component with the same feature specification as that with which it entered the syntactic derivation. A entered the derivation with underspecified gender and number features by virtue of being a Probe for these features. A therefore still carries these underspecified features, when it is submitted to the SM-interface (see the specification on A in (100)). Since A does not participate in any Agree relations, these two features are not shared with other syntactic nodes. Both gender and number are CI-uninterpretable on A. According to the condition in (101), they are therefore not interpretable at the SM-interface. A is thus interpreted at the SM-interface as in (102).

- (102) STEP #5: SM-INTERPRETATION
 A: [#i: , Gen:] → A: [∅]

On the two D-copies, gender and number are however both interpreted at the SM-interface. The reason for this is that the gender and number features of both Ds are shared with N, the element on which these features are CI-interpretable.

The next step in the derivation is to provide the morphosyntactic features with phonological content. This happens at Vocabulary Insertion. At this point in the derivation, N is spelled out as *hus*, the two Ds are spelled out as the definite suffix *-et* and A is spelled out as *stor-*. As for the absence of gender and number specification on A, I introduced in section 4.2.1.3 three VI-insertion rules that match a specific combination of gender and number features with a particular adjectival ending. These rules were given in (80) above and are repeated here in (103).

- (103) VI-INSERTION RULES FOR ADJECTIVAL INFLECTION IN SWEDISH:
- | | | | | |
|----|---------|--------------------------|---|-------------|
| a. | RULE A: | A-[Gen:neuter, #: sg] | → | A- <i>t</i> |
| b. | RULE B: | A-[Gen:non-neuter, #:sg] | → | A-∅ |
| c. | RULE C: | A-[∅] | → | A- <i>a</i> |

In this case, the elsewhere rule C applies, spelling out the adjectival ending as *-a*, as in (104).

- (104) STEP #6: VOCABULARY INSERTION
 A-[∅] → *stor-a*

After Vocabulary Insertion, linearization, local dislocation and *d*-support take place in the manner described in chapter 2 in order to yield the right surface form and order of morphemes. This results in the surface form in ((95b), repeated here in (105).

- (105) *det* *stor-a* *hus-et*
 the.NEUTER big-WEAK house-DEF.NEUTER
 ‘the big house’

This derivation shows that that my proposal that adjectives in definite DPs do not share features with N via Indirect Agree explains the absence of agreement in the Swedish weak adjectival inflection.

4.3.2. The weak adjectival paradigm

On my proposal on weak adjectival inflection, A never shares gender and number features in Swedish definite DPs. This is so because gender and number are fully specified on N in Swedish, i.e. they are always represented by attribute-value pairs (see section 4.1 of this chapter). Hence, Agree between D and N always deactivates D as a gender and number Probe. As a consequence, D in a definite DP never enters into Agree with A for gender and number, leaving these features on A unshared irrespective of the gender and number specification of N (see above for a full

illustration). This is shown in the table in (107). Because gender and number-features are CI-uninterpretable on A, the non-shared gender and number feature will be deleted from A at the SM-interface, given CI-dependent SM-interpretation (see (42)/(101) above). This is schematized in the third column of the table in (107). In the morphological component, A's gender and number specification is matched with a specific inflection morpheme through means of the three VI-insertion rules I proposed. These rules are repeated here in (106).

- (106) VI-RULES ADJECTIVAL INFLECTION IN SWEDISH:
- a. Rule A: A-[Gen:neuter, #: sg] → A-*t*
 - b. Rule B: A-[Gen:non-neuter, #: sg] → A- \emptyset
 - c. Rule C: A- \emptyset → A-*a*⁴⁴

Given that A is never specified for gender or number, only the default rule C can apply in definite DPs, as indicated in the fourth column of the table in (107). Hence, no matter the gender and number specification of N, the adjectival inflection is always *-a* in definite DPs, as in the fifth column of the table in (107).

- (107) NUMBER AND GENDER SPECIFICATION OF A AFTER NARROW SYNTAX, THEIR SM-INTERPRETATION, AND VOCABULARY INSERTION IN DEFINITE DPs

Specification N	Outcome Narrow syntax	SM-interpretation	VI-rule	Inflectional suffix
SG, NEUTER	[#: , Gen:]	[\emptyset]	C	<i>-a</i>
SG, NON-NEUTER	[#: , Gen:]	[\emptyset]	C	<i>-a</i>
PL, NEUTER	[#: , Gen:]	[\emptyset]	C	<i>-a</i>
PL, NON-NEUTER	[#: , Gen:]	[\emptyset]	C	<i>-a</i>

In this way, my proposal for weak adjectival inflection attributes the lack of gender and number distinctions on the Swedish weak adjectival inflection to the interplay between the syntactic and morphological component of the grammar. In the syntactic component, no full gender and number specification is licensed on A. This has two different causes. First, no direct Agree between A and N is triggered because of the status of A as an adjunct (cf. the dominance requirement (see chapter 3) Secondly, licensing through Indirect Agree is blocked in definite DPs. This is due to the intervention effect created by the higher D-copy. This higher D-copy is the result of the same instance of internal merge that played a pivotal role in explaining double definiteness in chapter 2. As a result of its adjunct status and the intervention of the higher D-copy, A reaches the morphological component without sharing any gender and number features with other syntactic nodes. As a result, the

⁴⁴ Certain adjectives do not take *-a* as their ending, but *-e*, see fn. 1.

morphological component cannot spell out any gender and number distinctions on the adjectival inflection, yielding weak adjectival inflection.

4.4. Conclusion

In this section, I demonstrated that my proposal of the strong-weak distinction accounts for adjectival inflection in Swedish. I first showed that the analysis of strong adjectival inflection in terms of Indirect Agree straightforwardly explains the gender and number distinctions marked by the strong adjectival inflection in DPs without articles. I then argued that it also accounts for the strong adjectival inflection in DPs introduced by the indefinite article, on condition that the indefinite article is analyzed as a numeral instead of an instance of D. Finally, I showed that my analysis of weak adjectival inflection straightforwardly explains the absence of agreement on attributive adjectives in Swedish definite DPs.

In the following section, I will show that my proposal of the strong-weak distinction accounts in a similar fashion the inflection on attributive adjectives in three other Germanic languages. After that, I will examine whether my proposal of chapter 2 concerning the structural positions of adjectives needs to be revised in the light of my analysis of the strong-weak distinction.

5. The strong-weak distinction in other Germanic languages

In this section, I examine the inflection on attributive adjectives in three Germanic languages: Norwegian, Danish and Dutch. This inflection is either completely or almost completely similar to that in Swedish. My proposal therefore accounts for the adjectival inflection in these languages in a similar fashion as for the Swedish facts.

5.1. Norwegian

The inflection on attributive adjectives in Norwegian strongly resembles that in Swedish. First, it displays a strong-weak distinction similar to that in Swedish. Secondly, the gender and number distinctions that are marked by the inflection are identical. The strong inflection marks gender (neuter singular (-*t*) vs. non-neuter (feminine/masculine) singular (- \emptyset)) and number (singular (-*t*/ \emptyset) vs. plural (-*e*)), while the weak inflection displays a complete gender and number syncretism. The complete Norwegian paradigm is given in the table in (108). In addition, the strong adjectival inflection is illustrated by the examples in (109), while the weak adjectival inflection is illustrated by those in (110). The glosses in these examples are mine.

(108) INFLECTION ON ATTRIBUTIVE ADJECTIVES IN (BOKMÅL) NORWEGIAN

	Non-neuter singular (Feminine/Masculine)	Neuter singular	Plural
Strong	-Ø	-t	-e
Weak	-e	-e	-e

(table adopted from Berit & Strandskogen 1995)

- (109) a. *en stor-Ø bil* MASC, INDEF, SG
a.MASC big-NONNEUT car
'a big car'
- b. *ei stor-Ø hytte* FEM, INDEF, SG
a.FEM big-NONNEUT cottage
'a big cottage'
- c. *et stor-t hus* NEUT, INDEF, SG
a.NEUT big-NEUT house
'a big house'
- d. *stor-e bil-er* MASC, INDEF, PL
big-PL car-PL
'big cars'
- e. *stor-e hytte-r* FEM, INDEF, PL
big-PL cottage-PL
'big cottages'
- f. *stor-e hus* NEUT, INDEF, PL
big-PL house
'big houses'
- (Berit & Strandskogen 1995: 70)
- (110) a. *den stor-e bil-en* MASC, DEF, SG
the.NON-NEUT big-WEAK car-DEF.MASC
'the big car'
- b. *den stor-e hytt-a* FEM, DEF, SG
the.NON-NEUT big-WEAK cottage-DEF.FEM
'the big cottage'
- c. *det stor-e hus-et* NEUT, DEF, SG
the.NEUT big-WEAK house-DEF.NEUT
'the big house'
- d. *de stor-e bil-ene* MASC, DEF, PL
the.PL big-WEAK car-DEF.PL
'the big cars'
- e. *de stor-e hytt-ene* FEM, DEF, PL
the.PL big-WEAK cottage-DEF.PL
'the big cottages'
- f. *de stor-e hus-ene* NEUT, DEF, PL
the.PL big-WEAK house-DEF.PL
'the big houses'
- (Berit & Strandskogen 1995: 70)

The only difference with Swedish is the form of the ending that signals the weak inflection and the plural in the strong inflection. In Norwegian, this ending is *-e*, while in Swedish this ending is either *-e* or *-a* depending on the adjective (cf. footnote 1 above).

The structure of DP in Norwegian is also almost identical to that in Swedish. First, Norwegian indefinite and definite articles display gender and number agreement with the noun, just like those in Swedish, as shown in (109) and (110). The only difference to this respect is that Norwegian has one additional grammatical gender. Instead of distinguishing only neuter vs. non-neuter gender like Swedish, it distinguishes between feminine, masculine, and neuter gender (Berit & Strandskogen 1995). The distinction between masculine and feminine is marked on the indefinite article (see (109a-b)) and the definite suffix (see (110a-b)), but not on the adjectival inflection and the freestanding definite article.⁴⁵ Secondly, Norwegian displays double definiteness, i.e. article doubling, in definite DPs with an adjective, just like Swedish (see chapter 2 and the examples in (110)).

Given these similarities between the two languages, I claim that the syntactic derivation of DP is identical in Norwegian and Swedish. In chapter 2, I already proposed this for definite DPs. I now extend this proposal to also include indefinite DPs. As a consequence, my analysis of strong-weak inflection accounts in the same way for the Norwegian facts as it did for Swedish. The strong adjectival inflection in Norwegian is thus also the result of Indirect Agree, while the weak adjectival inflection is due to the deactivation of the D-copies. As mentioned above, there are, however, two things that are different in Norwegian. First, *-e* is the elsewhere morpheme for adjectival inflection, instead of *-a*. Second, Norwegian has feminine gender. Two small changes to the VI-insertion rules that I proposed for Swedish (see (106)) will account for these two differences. First, I have to replace the *-a* ending in the Swedish VI-rule C with the Norwegian *-e* ending. Secondly, I have to change Swedish VI-rule B, so that it ensures that the strong $-\emptyset$ ending is inserted both with masculine and feminine singular nouns. This can easily be done by not specifying rule B for gender, as in (111). In that case, rule B applies in the strong adjectival inflection both in feminine and masculine singular DPs. The subset principle will however block it from applying in singular neuter DPs, as the more specific rule A can then also apply. These changes result in the VI-insertion rules in (111).

- (111) VI-RULES FOR THE INFLECTION ON ATTRIBUTIVE ADJECTIVES IN NORWEGIAN:
- | | | | | |
|----|---------|------------------------|---|-------------------------|
| a. | Rule A: | A-[Gen: neuter, #: sg] | → | A- <i>t</i> |
| b. | Rule B: | A-[#: sg] | → | A- \emptyset |
| c. | Rule C: | A- \emptyset | → | A- <i>e</i> (Elsewhere) |

These small changes to the VI-rules are all that is needed to apply my analysis to Norwegian.

⁴⁵ Since feminine is morphologically realized on some elements, it should be syntactically represented as a fully specified feature, i.e. as [Gen: fem], according to my proposal about the syntactic representation in section 2.1 of this chapter.

5.2. Danish

The inflection on attributive adjectives in Danish is identical to that in Norwegian. The full paradigm is given in the table in (113). The paradigm is illustrated for the strong inflection by the examples in (112) and for the weak inflection by those in (115). The glosses in these examples are mine.

(113) INFLECTION ON ATTRIBUTIVE ADJECTIVES IN DANISH

	Non-neuter singular	Neuter singular	Plural
Strong	-Ø	-t	-e
Weak	-e	-e	-e

(table adopted from Allan, Holmes & Landskær-Nielsen 1995: 73)

- (114) a. *en ung-Ø pige* NON-NTR, INDEF, SG
 a.NONNEUT young-NONNEUT girl
 'a young girl'
- b. *et stor-t hus* NEUTER, INDEF, SG
 a.NEUT big-NEUT house
 'a big house'
- c. *ung-e pige-r* NON-NTR, INDEF, PL
 young-PL girl-PL
 'young girls'
- d. *stor-e hus-e* NTR, INDEF, PL
 big-PL house-PL
 'big houses' (Allan et al. 1995: 72)
- (115) a. *den ung-e pige* NON-NTR, DEF, SG
 the.NON-NEUT young-WEAK girl
 'the young girl'
- b. *det stor-e hus* NEUTER, DEF, SG
 the.NEUT big-WEAK house
 'the big house'
- c. *de ung-e pige-r* NON-NTR, DEF, PL
 the.PL young-WEAK girl-PL
 'the young girls'
- d. *de stor-e hus-e* NEUTER, DEF, PL
 the.PL big-WEAK house-PL
 'the big houses' (Allan et al. 1995: 72)

Although the inflection on adjectives is the same as in Norwegian, Danish differs from Swedish and Norwegian in that it does not display double definiteness in definite DPs with an adjective, see (115). In chapter 2, I argued however that this lack of article doubling is the result of a morphological difference between Danish

on the one hand and Norwegian and Swedish on the other. Furthermore, I claimed that the syntactic derivation of definite DPs is identical in the three languages. As far as indefinite DPs are concerned, there are no remarkable differences between those in Danish and those in Swedish and Norwegian. Hence, I claim that they are derived in the same way in all three languages. As a result, my analysis of strong and weak adjectival inflection also accounts for Danish adjectival inflection.

As for the VI-rules, only a small readjustment to the Swedish VI-rules is needed in order to account for the Danish inflection. Like Norwegian, the adjectival ending for the weak inflection and the plural in the strong inflection is *-e*. The VI-rules for Danish are thus as in (116).

- (116) VI-RULES FOR INFLECTION ON ATTRIBUTIVE ADJECTIVES IN DANISH
- a. Rule A: A-[Gen:neuter, #: sg] → A-*t*
 - b. Rule B: A-[Gen: non-neuter, #: sg] → A- \emptyset
 - c. Rule C: A- \emptyset → A-*e* (elsewhere)

These VI-rules, combined with my analysis of strong and weak adjectival inflection, account for the inflection in Danish.

5.3. Dutch

Dutch differs from Swedish, Danish and Norwegian in that it has only two possible endings for attributive adjectives, *-e* and $-\emptyset$, instead of three. The paradigm for the inflection of attributive adjectives in Dutch is given in the table in (117). The paradigm is illustrated in (118) for the strong inflection and in (119) for the weak inflection.

- (117) INFLECTION ON ATTRIBUTIVE ADJECTIVES IN DUTCH

	Non-neuter singular	Neuter singular	Plural
Strong	-e	$-\emptyset$	-e
Weak	-e	-e	-e

- (118) a. *een oud-e man* NON-NTR, INDEF, SG
 a *old-e man*
 ‘an old man’
- b. *een oud- \emptyset huis* NEUTER, INDEF, SG
 a *old-NEUTER.SG.STRONG house*
 ‘an old house’
- c. *oud-e mann-en* NON-NTR, INDEF, PL
 old-e man-PL
 ‘old men’
- d. *oud-e huiz-en* NEUTER, INDEF, PL
 old-e house-PL
 ‘old houses’

- (119) a. *de oud-e man* NON-NTR, DEF, SG
 the old-e man
 ‘the old man’
- b. *het oud-e huis* NEUTER, DEF, SG
 the.NEUTER old-e house
 ‘the old house’
- c. *de oud-e mann-en* NON-NTR, DEF, PL
 the old-e man-PL
 ‘the old men’
- d. *de oud-e huizen* NEUTER, DEF, PL
 the old-e house-PL
 ‘the old houses’

In chapter 2, I argued that the syntactic derivation of the Dutch definite DP does not differ from its Swedish counterpart. In both languages, the presence of an attributive adjective triggers internal merge of D.⁴⁶ In addition, the Dutch definite D, like its Swedish counterpart, inflects for gender and number (see (119)). My analysis of weak adjectival inflection therefore also accounts for the weak adjectival inflection in Dutch. In definite DPs as those in (119), the higher D-copy is thus a deactivated gender and number Probe. As a consequence, no gender and number agreement is licensed on A. This accounts for the gender and number syncretism in the weak adjectival inflection.

I claimed that the strong adjectival inflection is the result of Indirect Agree. The case assigner of the DP in which the adjective is contained first enters into an Agree relation with A and then with N. This licenses feature sharing between A and N without a direct Agree relation between A and N. This analysis of strong adjectival inflection in terms of Indirect Agree also accounts for Dutch strong adjectival inflection. In Dutch the feature sharing between the adjective and the noun that is the result of Indirect Agree between A and N is spelled out on the adjective, through means of the two VI-rules in (120).

- (120) VI-RULES INFLECTION FOR ATTRIBUTIVE ADJECTIVES IN DUTCH
- a. RULE A: A-[Gen: neuter, #:sg] → A -∅
- b. RULE B: A-[∅] → A-e (Elsewhere)

There is however one small difference between Swedish and Dutch. For Swedish, I argued that the indefinite article is a numeral with probing features. The main reason to argue that the Swedish indefinite article is a Probe is that it inflects for gender and number. It takes the form *en* if it introduces a noun with non-neuter gender and the form *ett* if it introduces a noun with neuter gender. However, this is not the case in Dutch. In Dutch, the indefinite article takes the same shape in both singular neuter DPs as in (118a) and in singular non-neuter DPs as in (118b). In both cases, the indefinite article is spelled out as *een*. Dutch DPs with an indefinite article thus lack

⁴⁶ In chapter 2, I attributed the fact that only one of these Ds is spelled out in Dutch, to a morphological property. In Dutch, the definite article is a free morpheme rather than a suffix as in Swedish.

morphological evidence for the probehood of the indefinite article. I therefore claim that it is not a Probe. In Swedish, the inflection on the indefinite article was licensed by the case assigner first entering into an Agree relation with the indefinite article, before entering into Agree relations with the adjective and the noun. Given that the Dutch indefinite article is not a Probe, it has no (underspecified) gender and number features. This has the consequence that the case-assigner does not enter into an Agree relation with the indefinite article before it enters into an Agree relation with the adjective and the noun. This has however no consequence for the licensing of strong adjectival inflection through means of Indirect Agree. As shown by the licensing of the strong adjectival inflection in Swedish DPs without an article (see section 4.2.1 above), this licensing does not require the presence of an indefinite article that participates in Agree. Unlike in Swedish, strong adjectival inflection is therefore licensed in Dutch without the indefinite article participating in feature sharing. This minor difference is the only syntactic difference between Dutch and Swedish with respect to licensing of strong adjectival inflection.

In this way, my proposal also accounts for the strong and weak adjectival inflection in Dutch. The licensing of the inflection on attributive adjectives is almost identical in Dutch and Swedish. The only two differences are that Dutch has one inflectional ending less and that the Dutch indefinite article does not participate in the feature sharing that licenses strong adjectival inflection.

6. A note on the position of adjectives in definite DPs

In chapter 2, I claimed that attributive adjectives in Swedish and most other Germanic languages are adjoined to DP. The main argument in favor of this claim was the observation that the inflection of attributive adjectives is sensitive to definiteness. This sensitivity manifests itself through the strong-weak alternation on the adjectival inflection. I argued in chapter 2 that the observation that the distribution of strong and weak adjectival depends on definiteness shows that D is in the search domain of A. In that chapter, I used Chomsky's (2000, 2001) definition of search domain. According to that definition, the search domain of the Probe was the structure that the Probe c-commands. Under this c-command definition of search domain, 'A is in the search domain of D' equals 'A c-commands a definite D'. Adopting the assumption that attributive adjectives are adjuncts (Svenonius 1994), I therefore concluded that attributive As are adjoined to DP.

In chapter 3, I however replaced the c-command requirement on Agree by the dominance requirement. Under the dominance requirement, the search domain of the Probe is constituted by the structure dominated by that Probe, not the structure c-commanded by that Probe. In case attributive adjectives are adjoined to DP, A or a node of the projection of A does not dominate D (see the structure in (121)).

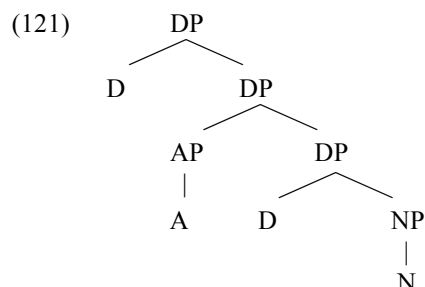

Under the dominance requirement on Agree, A(P) does thus not have D in its search domain in (121). Therefore, it seems that the original motivation to adjoin AP to DP, i.e. the sensitivity of the adjectival inflection to D's definiteness, is lost under the dominance requirement. However, this is only apparent under my analysis of weak adjectival inflection.

Above, I analyzed weak adjectival inflection as the absence of number and gender agreement on A. Under my analysis, this absence was caused by the deactivation of the higher D-copy in (121) as a Probe. This deactivation ensured that feature sharing between A and N through means of Indirect Agree is blocked in two ways. First, it prevents the higher and lower D-copy from entering into an Agree relation with A. Secondly, it ensures that no DP-external Probe could do so as well, because the higher D-copy acts as an intervener for such Agree. The higher D-copy only has this effect in case two conditions are met. First, D must establish Agree with N before internal merge takes place, in order to ensure the (partial) deactivation of the higher D-copy. Secondly, the higher D-copy is the result of movement, i.e. of internal merge, from a position that is lower than the adjunction site of A to a position that is higher than this adjunction site. If the lower D-copy were to be merged at a position above this adjunction site, it would license number and gender agreement on A by first entering into Agree with A and then with N. If the higher D-copy were to be internally merged at a position below the adjunction site, it could not act as an intervener for Agree between A and DP-external Probe. In that case, licensing of gender and number agreement on A through Indirect Agree could not be blocked.

Under my account, the licensing of weak adjectival inflection thus requires A to be merged later than D, but before D undergoes movement. On the assumption that attributive adjectives are adjuncts, the licensing of weak adjectival inflection therefore remains an argument to assume that attributive adjuncts are adjoined to DP despite the replacement of the c-command requirement with the dominance requirement.

7. Conclusion

I started this chapter with three questions about strong and weak adjectival inflection in Germanic. These three questions are repeated here in (122).

- (122) **QUESTIONS**
- I. LICENSING:
How is the strong and weak adjectival inflection licensed?
 - II. LOSS OF DISTINCTIONS:
Why does the weak adjectival inflection express less (or even no) case, number, gender distinctions than the strong adjectival inflection?
 - III. DISTRIBUTION
How can the distribution of strong and weak adjectival inflection be accounted for?

My analysis of strong and weak adjectival inflection offers the following answers to these three questions.

In the case of strong adjectival inflection, the answer to the first question in (122) is that the inflection on the adjective is licensed indirectly through means of Indirect Agree. A Probe that is higher in the syntactic structure than the adjective first enters into Agree with A and then with N. This indirectly licenses the sharing of gender and number features between A and N. This sharing is then spelled out as strong adjectival inflection on the adjective. I argued that the weak adjectival inflection is licensed in case D is deactivated as a Probe at an earlier stage of the derivation. In that case, D prevents A from sharing both gender and number features with N. This lack of sharing is spelled out as weak adjectival inflection.

This deactivation of D also answers the second question in (122). In definite DPs, D is already deactivated as a gender and number Probe when it is internally merged. On the one hand, it will therefore not enable feature sharing between A and N through means of Indirect Agree. On the other hand, it will prevent any other Probe from doing so, because it acts as an intervener for any Agree relation with A. As a result, no gender and number distinctions are licensed on A. This explains the loss of distinctions in the weak adjectival inflection.

The answer to the final question in (122) is that weak adjectival inflection occurs in definite DPs, because D in that case is a gender and number Probe that is deactivated before it undergoes internal merge. The strong adjectival inflection occurs in those DPs in which D is not a Probe. This allows another Probe, the case assigner of the DP in question, to license number and gender specifications on A via Indirect Agree.

In addition to Swedish, I showed that my proposal also accounts for strong and weak adjectival inflection in Dutch, Danish and Norwegian. However, the inflectional paradigms in these languages are relatively simple. They only consist of three or two different endings. A language such as German has a far more complicated inflectional paradigm for attributive adjectives. Like the languages studied so far, German has strong and weak adjectival inflection. However, German adjectives with strong adjectival inflection not only display number and gender agreement, but also case agreement. Furthermore, the weak adjectival inflection displays some minor distinctions instead of a complete syncretism. Given this complexity of the German paradigm, German constitutes the ultimate testing ground

for my analysis. The inflection of attributive adjectives in German is therefore the subject of the next chapter.

Chapter 5

Strong and weak adjectival inflection in German

1. Introduction

In the previous chapter, I introduced my analysis of strong and weak adjectival inflection. I showed that it accounts for inflection on attributive adjectives in Swedish, Norwegian, Swedish and Dutch. In this chapter, I examine strong and weak adjectival inflection in German. The German adjectival inflectional system differs considerably from those studied in the previous chapter. Nevertheless, I will show that my analysis also straightforwardly accounts for the German facts. In this way, this chapter offers additional empirical support for my analysis of strong and weak adjectival inflection.

This chapter is organized as follows. I will first introduce the facts concerning adjectival inflection in German. I will show how German is different from the languages in the previous chapter. I will then show how my analysis accounts for the strong adjectival inflection in German. After that, I turn to the weak adjectival inflection. Finally, I discuss the so-called mixed paradigm (cf. Sternefeld 2004, Roehrs 2006), which takes endings from both the strong paradigm and the weak paradigm.

2. German adjectival inflection: the data

In German, the inflection on attributive adjectives displays a strong-weak distinction, just like in Swedish and the other languages that I discussed in the previous chapter. This is illustrated in (1) and (2). The adjectives in the articleless DPs in (1) all carry a strong ending, while the adjectives in the definite DPs in (2) all take a weak ending.

- | | | | | |
|-----|----|------------------------------------------------------------|---------------------|-----------------------|
| (1) | a. | <i>kalt-er</i>
cold-MASC.NOM.SG.STRONG
'cold wine' | <i>Wein</i>
wine | STRONG, NOM, MASC, SG |
| | b. | <i>kalt-es</i>
cold-NEUTER.NOM.SG.STRONG
'cold beer' | <i>Bier</i>
beer | STRONG, NOM, NEUT, SG |

- c. *kalt-e* *Wurst* STRONG, NOM, FEM, SG
cold-FEM-NOM.SG.STRONG sausage
'cold sausage'
- (2) a. *der* *kalt-e* *Wein* WEAK, NOM, MASC, SG
the.NOM.MASC.SG cold-WEAK wine
'The cold wine'
- b. *das* *kalt-e* *Bier* WEAK, NOM, NEUT, SG
the.NOM.NEUTER.SG cold-WEAK beer
'the cold beer'
- c. *die* *kalt-e* *Wurst* WEAK, NOM, FEM, SG
the.NOM.FEM.SG cold-WEAK sausage
'the cold sausage'

The full paradigm of strong adjectival inflection is given in the table in (3). The paradigm for the weak adjectival inflection is given in the table in (4).

(3) STRONG ADJECTIVAL INFLECTION IN GERMAN

	Singular			Plural
	Masculine	Neuter	Feminine	
Nominative	-er	-es	-e	-e
Accusative	-en	-es	-e	-e
Dative	-em	-em	-er	-en ¹
Genitive	-en	-en ²	-er	-er

(4) WEAK ADJECTIVAL INFLECTION IN GERMAN

	Singular			Plural
	Masculine	Neuter	Feminine	
Nominative	-e	-e	-e	-en
Accusative	-en	-e	-e	-en
Dative	-en	-en	-en	-en
Genitive	-en	-en	-en	-en

Although German also displays a strong-weak distinction, the adjectival inflectional system in German differs in three respects from that in the languages I discussed in the previous chapter. These differences concern case agreement, distinctions marked in the weak adjectival inflection, and an additional inflectional paradigm.

First of all, the adjectival inflection in German displays case agreement in addition to agreement in gender and number, as can be seen in the tables in (3) and (4). As a consequence, the number of possible feature combinations that is relevant for the adjectival inflection is considerably higher in German than it is in a language like Swedish. Swedish attributive adjectives only display agreement in two

¹ In the dative plural, the noun gets an -n suffix.

² In the genitive singular masculine and neuter, the noun gets an -(e)s suffix

numbers, singular and plural, and two genders, neuter and non-neuter. There is no case agreement. There are thus only $2 \times 2 = 4$ different possible combinations of features on the adjective. In German, there are three genders (masculine, neuter, and feminine), two numbers (singular and plural) and four different cases (nominative, accusative, dative and genitive) that determine the shape of the adjectival inflection. This makes that there are $3 \times 2 \times 4 = 24$ different possible feature combinations on the adjective. This renders adjectival inflection in German far more complex than that in Swedish.

Second, the paradigm of weak adjectival inflection in German consists of two different endings: *-e* and *-en* (see the table in (4)). Weak adjectival inflection is thus not invariant in German, in contrast to languages like Swedish.

Third, German has, in addition to the strong and weak paradigms, a third paradigm of adjectival inflection (see among others Sternefeld (2004) and Roehrs (2006)). This additional paradigm is also known as the mixed paradigm, because it partly consists of endings from the strong paradigm and partly of endings from the weak paradigm. For masculine nominative singular, neuter nominative singular and neuter accusative singular, the adjective receives a strong ending. In all remaining cases, the adjective receives a weak ending. This is schematized in (5).

(5) MIXED ADJECTIVAL INFLECTION:

STRONG

		Singular	
		Masculine	Neuter
Nominative		-er	-es
Accusative			-es

+

WEAK

		Singular			Plural	
		Masculine	Neuter	Feminine		
Nominative					-e	-en
Accusative	-en				-e	-en
Dative	-en	-en			-en	-en ³
Genitive	-en ⁴	-en			-en	-en

=

MIXED

		Singular			Plural	
		Masculine	Neuter	Feminine		
Nominative		-er	-es		-e	-en
Accusative	-en		-es		-e	-en
Dative	-en	-en			-en	-en ⁵
Genitive	-en ⁶	-en			-en	-en

= strong ending
 = weak ending

Adjectives take this mixed inflection in DPs that are introduced by the indefinite article *ein*, by possessive pronouns, like *mein* 'my' or *unser* 'our', or by the negative quantifier *kein* 'no'.⁷ The mixed adjectival inflection is illustrated in (6). In (6), the adjective *alt* 'old' occurs in a neuter singular DP. As the DP in question is intro-

³ In the plural dative, the noun takes an additional *-n* ending.

⁴ In the masculine and neuter genitive singular the noun takes an additional *-s* ending.

⁵ In the plural dative, the noun takes an additional *-n* ending.

⁶ In the masculine and neuter genitive singular the noun takes an additional *-s* ending.

⁷ Note that the morpheme that realizes the indefinite article, i.e. *ein*, is also part of some possessive pronouns (cf. *m-ein* 'my') and the negative quantifier *k-ein* 'no'. I will come back to this in footnote 17 below.

duced by the indefinite article, *alt* inflects according to the mixed paradigm. Hence, *alt* receives a strong ending in the nominative (6a) and a weak ending in the dative (6b).

- (6) a. *ein alt-es Haus* MIXED, NOM, NEUT, SG
 a old-NEUTER.SG.NOM.STRONG house
 ‘an old house’
- b. *ein-em alt-en Haus* MIXED, DAT, NEUT, SG
 a-DATIVE.SG.NEUTER old-WEAK house
 ‘an old house’

Unlike in Swedish, German adjectives in indefinite DPs thus do not inflect according to the strong paradigm. Strong adjectival inflection in German is limited to DPs without an article as those in (1). The distribution of the strong, weak and mixed adjectival inflection is schematized in (7).

- (7) DISTRIBUTION OF ADJECTIVAL INFLECTION IN GERMAN

DP	Adjectival inflection
Articleless	Strong
Indefinite article	Mixed
Definite article	Weak ⁸

Given these characteristics, adjectival inflection in German looks rather different from that in Swedish. However, my analysis of strong and weak adjectival inflection in Swedish straightforwardly accounts for the adjectival inflection in German as well. After determining the syntactic representation of the features that are involved in agreement on German attributive adjectives, I will first show this for the strong inflection.

3. The representation of gender, number, and case in German

In the previous chapter, I argued that the syntactic representation of morphosyntactic features depends on the morphological realization of these features. In order to characterize this dependency, I proposed the mapping rules in (8).

⁸ Weak adjectival inflection also occurs in DPs introduced by determiners like *dieser* ‘this’, *jener* ‘that’, *aller* ‘all’, *beide* ‘both’, *solcher* ‘such’ and *welcher* ‘which’ (Drosdowski 1984: 288-297). In order to keep things as simple as possible, I will only discuss weak adjectival inflection in the context of the definite article. The analysis of German weak adjectival inflection that I will develop below will also account for weak adjectival inflection triggered by the above-mentioned determiners, on condition that these determiners are analyzed as instances of D.

(8) MORPHO-DRIVEN FEATURE REPRESENTATION

If an interpretation of a particular feature is:

- a. **morphologically realized**, the interpretation is mapped onto a fully specified feature representation, i.e. onto an attribute-value pair.
- b. **morphologically unrealized**, the interpretation is mapped onto an underspecified feature representation, i.e. onto an attribute.

The consequence of this morpho-driven feature representation is that features might differ with respect to the interpretability of the attribute in their syntactic representation. Those features that possess a morphologically unrealized interpretation have a syntactic representation in which the attribute can be interpretable when it lacks a value. Those that possess only morphologically realized interpretations have a syntactic representation in which the attribute is uninterpretable when it lacks a value. In the previous chapter, I argued that this difference is relevant for Agree. Before analyzing German adjectival agreement in terms of Agree, I will therefore first determine the syntactic representation of the features involved in this agreement, just like I did in the previous chapter for the features involved in adjectival agreement in Swedish. Like I indicated in the previous section, three features participate in adjectival agreement in German: gender, number, and case. I will start my discussion of the syntactic representation of these features with the gender feature.

The gender feature has three different interpretations in German: masculine, neuter, and feminine. In order to determine how these interpretations are mapped onto syntactic representations under morpho-driven feature representation, I need to verify whether each interpretation is morphologically realized or not. In this respect, consider first how gender is spelled out by the strong adjectival inflection. The form of the suffix realizing strong adjectival inflection depends on the gender of the noun that is modified. If the adjective modifies nominative singular nouns, the strong adjectival ending is different for each of the three genders. This is illustrated in (9a-c). The different endings are listed in table in (9d).

- (9) a. *gut-er Wein* b. *gut-es Bier* c. *gut-e Wurst*
 good wine.MASC good beer.NEUT good sausage.FEM
 ‘good wine’ ‘good beer’ ‘good sausage’

d. STRONG ADJECTIVAL INFLECTION (NOMINATIVE SINGULAR)

	Masculine	Neuter	Feminine
Nominative	-er	-es	-e

Gender not only co-determines the form of strong adjectival inflection, but it also plays a role in determining the actual shape of determiners, like the definite article. Like the strong adjectival inflection, the inflection of the definite article can correspond to the gender of the noun it introduces. This is for instance the case when the definite article introduces singular nouns with nominative case, as in (10a-c).

The distributional properties of the forms of definite article are summarized in the table in (10d).

- (10) a. *der Wein*
the wine.MASC
'the wine'
- b. *das Bier*
the beer.NEUT
'the beer'
- c. *die Wurst*
the sausage.FEM
'the sausage'

d. GERMAN DEFINITE ARTICLES (NOMINATIVE SINGULAR)

	Masculine	Neuter	Feminine
Nominative	der	das	die

On the basis of the data in (9) and (10), one might have the impression that all three interpretations of the gender feature are morphologically realized in the nominative singular. However, this is not the case. The ending *-e* that occurs on adjectives modifying singular feminine nouns with nominative case as in (9c), is also the ending that is found on adjectives in plural DPs. In plural DPs, the noun can however be of any gender. This is illustrated in (11).

- (11) a. *gut-e Wein-e*
good wine.MASC-PL
'good wines'
- b. *gut-e Bier-e*
good beer.NEUT -PL
'good beers'
- c. *gut-e Würst-e*
good sausage.FEM-PL
'good sausages'

The fact that it occurs with plural nouns of any gender shows that *-e* does not realize feminine. The same goes for the definite article *die*. This form of the definite article also occurs in the plural with nouns of any gender, as in (12).

- (12) a. *die Wein-e*
the wine.MASC-PL
'the wines'
- b. *die Bier-e*
the beer.NEUT -PL
'the beers'
- c. *die Würst-e*
the sausage.FEM-PL
'the sausages'

Like *-e*, *die* therefore does not realize feminine in the nominative singular.⁹ In fact, feminine is never realized; not only in the nominative, but also in the other cases. In order to appreciate this, consider the complete strong adjectival paradigm in the table in (4) above, repeated here in (13), as well as the inflectional paradigm of the definite article in (14).

⁹ Note that a similar argument can be made on the basis of personal pronouns in which the gender neutral plural third person and the feminine singular third person are realized by the same form, *sie*.

(13) STRONG ADJECTIVAL INFLECTION IN GERMAN

	Singular			Plural
	Masculine	Neuter	Feminine	
Nominative	-er	-es	-e	-e
Accusative	-en	-es	-e	-e
Dative	-em	-em	-er	-en ¹⁰
Genitive	-en	-en ¹¹	-er	-er

(14) INFLECTION OF THE GERMAN DEFINITE ARTICLE

	Singular			Plural
	Masculine	Neuter	Feminine	
Nominative	der	das	die	die
Accusative	den	das	die	die
Dative	dem	dem	der	den
Genitive	des	des	der	der

In these two tables, all the forms that occur in the 'singular -feminine' column also appear in the 'plural' column. Given that there are no gender distinctions in the plural, this means that all the forms of the definite article or the strong adjectival inflection that occur in combination with feminine singular nouns are also found with plural nouns of any gender. Hence, feminine is not morphologically realized.^{12,13}

¹⁰ In the dative plural, the noun gets an -n suffix.

¹¹ In the genitive singular masculine and neuter, the noun gets an -(e)s suffix

¹² -en and den in (13) and (14) only occur in the plural, not in the feminine. This is however irrelevant for the present discussion, because the point is that all the feminine forms occur in the plural, not the other way around.

¹³ The conclusion that German does not morphologically realize one of its genders sets German apart from Swedish. As I showed in chapter 4, the two genders in Swedish, non-neuter and neuter, were both morphologically realized.

As shown in the main text, the argument for claiming that feminine is not morphologically realized in German hinges on the observation that the forms that occur with feminine nouns in the singular all occur with nouns of any gender in the plural. Like German, Swedish definite articles and strong adjectival inflection do not express gender distinctions in the plural, while they do in the singular. However, unlike in German, none of the singular forms is identical to the plural form, as can be seen in the table in (i).

(i) SWEDISH: STRONG ADJECTIVAL INFLECTION AND THE FREESTANDING DEFINITE ARTICLE

	Singular		Plural
	Neuter	Non-neuter	
Strong adjectival inflection	-t	-∅	-a
Freestanding definite article	det	den	de

Given morpho-driven feature representation, this observation has consequences for the way in which feminine is syntactically represented. In accordance with clause (b) of the proposal in (8), feminine is syntactically represented as a gender attribute without a value, i.e. as [Gen:]. Unlike feminine, neuter and masculine are morphologically realized. In the ‘masculine’ and ‘neuter’ columns in the tables in (13) and (14), there are morphemes that do not appear in the ‘plural’ column, like for instance *-es* or *das*. These morphemes do not appear in a context that is neutral with respect to gender, i.e. in the plural. They therefore realize masculine and neuter gender. In accordance with clause (a) of the proposal in (8), masculine and neuter are mapped onto attribute-value pairs. These pairs consist of the gender attribute (*Gen*) and the values for masculine (*masc*) and neuter (*neut*). Combining these results, the syntactic representation of gender in German is as in (15).¹⁴

(15) GENDER IN GERMAN

Interpretation	Syntactic representation
‘Feminine’	[Gen:]
‘Masculine’	[Gen: masc]
‘Neuter’	[Gen: neuter]

Let’s now consider the syntactic representation of number. Like in Swedish and English, plural is morphologically realized on the noun in German by plural suffixes. This can be seen in (12) above, repeated here in (16).

- (16) a. *die Wein-e*
the wine.MASC-PL
‘the wines’
- b. *die Bier-e*
the beer.NEUT-PL
‘the beers’
- c. *die Würst-e*
the sausage.FEM-PL
‘the sausages’

Given this morphological realization, the plural interpretation of the number feature is syntactically represented as an attribute-value pair, just like in English and Swedish (cf. (8a)). I take this attribute-value pair to be [#: pl], in which # is the number attribute and *pl* the plural value.

Just like in Swedish and English, singular, the other interpretation of the number feature, is not marked on German nouns. The singular counterparts of the plural nouns in (16) just consist of the nominal stem, (17).

Given that none of the singular forms is identical to the gender neutral plural, both genders in Swedish are morphologically realized. I refer the reader to chapter 4 for a more in depth discussion of Swedish gender realization

¹⁴ Yves d’Hulst and David Pesetsky (personal communication) both wonder why given the representation in (15) the expletive in German is the neuter *es* ‘it’ instead of the feminine *sie* ‘it’. I will leave this question to further research.

- (17) a. *das Kind* b. *die Frau* c. *der Mann*
 the child the woman the man
 ‘the child’ ‘the woman’ ‘the man’

In the previous chapter, I argued that singular in Swedish, although not marked on nouns, was morphologically realized on the definite article. However, this is not the case in German. At first sight, this claim seems counter-intuitive, because there are forms of the definite article that only occur in the singular, like *das*, *dem* and *des*, see the table in (14), repeated below in (18).

- (18) INFLECTION OF THE GERMAN DEFINITE ARTICLE

	Singular			Plural
	Masculine	Neuter	Feminine	
Nominative	der	das	die	die
Accusative	den	das	die	die
Dative	dem	dem	der	den
Genitive	des	des	der	der

On the basis of this observation, one might be inclined to conclude that singular is morphologically realized in German. However, there is another possibility. As we have seen above, there are no gender distinctions in the plural, but there are in the singular. It is therefore possible that the singular-plural opposition is not the result of the morphological realization of singular and plural number. Instead, this distinction might just be a byproduct of the fact that gender is morphologically realized in the singular, but not in the plural. In that case, a definite article like *das* only morphologically realizes neuter gender, not singular number. It would then only occur with singular nouns, because it cannot morphologically realize gender when it introduces plural nouns.¹⁵

There is evidence that singular is indeed not morphologically realized. I argued above that feminine gender is not morphologically realized. Hence, definite articles that introduce feminine singular nouns are similar to those that introduce plural nouns in the sense that they are both not specified for gender. This makes a prediction about the form of definite articles introducing singular feminine nouns, in case singular is morphologically realized. If singular number were morphologically realized, the definite articles that introduce singular feminine nouns would be different from those that introduce plural nouns with respect to the number feature they realize. In that case, they would be expected to differ in form from those that introduce plural nouns.

¹⁵ As shown in chapter 4 and footnote 13 above, Swedish also only expresses gender distinctions in the singular, not in the plural. It would therefore also be theoretically possible to analyze the singular-plural distinction in Swedish in terms of the presence vs. absence of gender realization. However, I claimed that the L1 learner does not consider this analysis because there is no positive evidence to back this up. I refer the reader to chapter 4 for a more detailed discussion. In German, there is however positive evidence for the L1 learner to analyze the singular-plural distinction in terms of gender realization, as I will show below.

This prediction is not borne out. As I discussed above, all the forms of the definite article that are used to introduce feminine singular nouns are also used to introduce plural nouns (see the table in (18)). This shows that singular is not morphologically realized on definite articles introducing singular feminine nouns. As argued above, the definite articles that introduce neuter and masculine nouns are already different from those introducing plural nouns in that they realize gender. The differences in form between these two groups of definite articles could thus be explained in terms of gender realization only. This, in combination with the conclusion that singular is also not realized on the definite articles that introduce singular feminine nouns, shows that there is no positive evidence for postulating that singular is morphologically realized on the definite article in German.¹⁶

The singular is also not morphologically realized by the strong adjectival inflection. The reason for this is that the strong adjectival inflection signals the same morphosyntactic distinctions as the inflection of the definite article. One can easily verify this by comparing the tables in (13) and (14) above. My argumentation for the claim that singular is morphologically unrealized therefore straightforwardly carries over to the strong adjectival inflection.

Singular is thus morphologically unrealized in German.¹⁷ Under my proposal that morphologically unrealized feature interpretations are mapped onto attributes without values, singular is syntactically represented in German by the number attribute (#:) without a value. Combining this representation with that of the plural, number in German is syntactically represented as in (19).

(19) NUMBER IN GERMAN

Interpretation	Syntactic Representation
'singular'	[#:]
'Plural'	[#: pl]

¹⁶ Again German is different from Swedish. In Swedish, there was positive evidence for the morphological realization of singular, because all the forms that occurred in the singular were distinct from the plural ones (see chapter 4 and footnote 13 above).

¹⁷ One might object that singular is morphologically realized in German by indefinite articles, because these are incompatible with plural nouns (cf. **eine Frau-en* 'a women'). This incompatibility is probably not due to the fact that the indefinite article is specified for a singular number feature in syntax. Instead, the incompatibility likely arises because the semantic function that the German indefinite article represents is incompatible with plural nouns. The main argument in favor of this claim is that the indefinite article *ein-* can also appear as part of other determiners, like *k-ein* 'no' or possessive pronouns like *m-ein* 'my'. In the singular, these elements inflect like the indefinite article. Contrary to the indefinite article, these elements have plural forms as is shown in (i).

- (i) a. *meine Kind-er* b. *kein-e Kind-er*
 my child -PL no child-PL
 'my children' 'no children'

If *ein* realized a singular number feature, it would be unexpected that *ein* as part of other determiners can take plural forms. Moreover, one could also not claim that the inflectional endings of the indefinite article realize a singular number feature. In the cases that the indefinite article takes an inflectional ending, this ending is identical to those of the strong adjectival inflection. As I argued in the main text, these endings do not realize singular number.

The final feature that is involved in adjectival agreement in German is case. The German case feature has four different interpretations: nominative, accusative, dative and genitive. Unlike for gender and number, there is no indication that any of these interpretations is not morphologically realized. Despite some syncretism elsewhere in the paradigm (see the paradigms for strong adjectival inflection in (13) and the one for definite articles in (14)), all four different case interpretations are realized in the masculine singular.¹⁸ This is illustrated for the definite article in (20).

(20) GERMAN DEFINITE ARTICLES (MASCULINE SINGULAR)

Nominative	Accusative	Dative	Genitive
<i>der</i>	<i>den</i>	<i>dem</i>	<i>des</i>

Given the fact that every case interpretation is morphologically realized in (20), all four case interpretations are syntactically represented as attribute-value pairs. These four attribute-value pairs are given in (21). In the table in (21), *case* stands for the case attribute, *nom* for the nominative value, *acc* for the accusative value, *dat* for the dative value, and *gen* for the genitive value.^{19,20}

(21) CASE IN GERMAN

Interpretation	Syntactic Representation
'nominative'	[Case: nom]
'accusative'	[Case: acc]
'dative'	[Case: dat]
'genitive'	[Case: gen]

I now have established the syntactic representations of the three features involved in adjectival agreement in German. Note that the syntactic representations of gender and number in German (see (15) and (19) above) are crucially different from those in Swedish. In German, number and gender each have a syntactic representation in which the attribute is interpretable without a value. In the previous chapter, I however argued that number and gender in Swedish have a syntactic representation in which the attribute is uninterpretable without a value. This difference will play an important role in my analysis of the differences between Swedish and German concerning weak adjectival inflection. Before investigating weak adjectival inflection, I will however first discuss strong adjectival inflection in German.

¹⁸ Given my conclusion that singular is syntactically represented as an underspecified number feature, it might be better to refer to *masculine singular* as *masculine non-plural*. However, in order to simplify the discussion, I will use the traditional terminology *singular* instead of non-plural for descriptive use.

¹⁹ In section 5.1.2 below, I will argue that there is a difference between accusative/nominative and genitive/dative with respect to the point of the derivation at which the case-value is associated with the case-attribute.

²⁰ Note that this is crucially different from the research tradition that assumes a featural decomposition of case in the tradition of Jakobson (1936).

4. Strong adjectival inflection

In the previous chapter, I proposed that strong adjectival inflection is the result of Indirect Agree between A and N. This instance of Indirect Agree is licensed by the case assigner of the DP in which the adjective is contained. This case assigner first enters into an Agree relation with A and then with N. As a consequence, A and N share features, despite the absence of a direct Agree relation between them. These shared features are then spelled out on A as strong inflection. In this section, I argue that this analysis also straightforwardly accounts for strong adjectival inflection in German.

German strong adjectival inflection differs in two ways from its Swedish counterpart, which I discussed in the previous chapter. The first difference concerns the contexts in which strong adjectival inflection is licensed. In Swedish, strong adjectival inflection occurs both in DPs with an indefinite article and in DPs without an article (see the previous chapter). In German, strong adjectival inflection is however only licensed in DPs that are not introduced by an article, as in (22).²¹

- | | | | |
|------|-------------------------|-------------|-----------------------|
| (22) | <i>kalt-en</i> | <i>Wein</i> | STRONG, ACC, MASC, SG |
| | cold-MASC.ACC.SG.STRONG | wine | |
| | ‘cold wine’ | | |

In this section, I will only consider the licensing of strong adjectival inflection in German DPs without an article. The question why German does not allow for strong adjectival inflection in DPs introduced by the indefinite article will be addressed in section 6 below.

The second difference between German and Swedish strong inflection concerns case. Swedish strong inflection does not display case agreement. In the previous chapter, I therefore did not discuss the way in which case assigners license case agreement. However, strong adjectival inflection in German does display agreement in case, in addition to agreement in gender and number (see the table in (3) above). I therefore have to specify how case agreement is licensed. I propose that attributive adjectives in German are case Probes, in addition to being gender and number Probes. As discussed in the previous chapter, I adopted Chomsky (2001)’s proposal that case assigners are Probes and that case is assigned to the Goal under Agree. On the feature sharing view of Agree, this proposal can be reformulated as follows. Agree triggered by a case assigning Probe not only results in the sharing of features that originated on the Goal, but also in the sharing of the case feature that originated on the Probe. When the case-assigner enters into an Agree relation with the adjective by virtue of its probing gender and number features, the adjective will not only share gender and number features with this case assigner, but also case features. Put differently, I propose that the underspecified probing case feature on the adjective is replaced by feature sharing with the fully specified case feature of the case assigner. As a consequence, strong adjectival inflection in German spells out case.

²¹ I abstract away here from the strong endings that occur as part of the mixed paradigm on adjectives in DPs with an indefinite article. These endings will be discussed in section 6 below.

Taking into account this way of how case is licensed on the adjective, let's consider how Indirect Agree licenses German strong adjectival inflection. The first step that is relevant to this licensing is the case assigner (X in (23)) entering into an Agree relation with A (*Agree 1* in (23)). This Agree relation has two different consequences. First, the case assigner X and A share unvalued gender and number features. Second, X shares a specified case feature with A. Given that Agree with A does not deactivate its probing features, the case assigner X then enters into an Agree relation with N (*Agree 2* in (23)). This results in the sharing of the number, gender features of N between N and the case assigner. In addition, it leads to the sharing of the case feature of the case assigner between X and N. Because all these features were already shared between A and the case assigner X, *Agree 2* also associates A with the gender and number features of N (Indirect Agree).

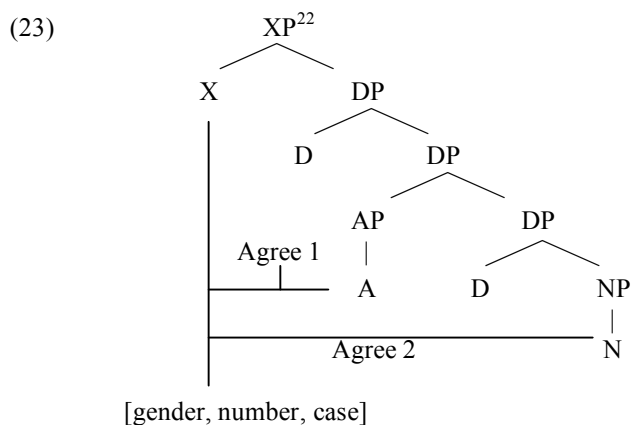

In this way, adjectives in German articleless DPs are always associated with the gender and number features of N and with the case feature of the case assigner. In the morphological component, VI-realization rules spell out these features as the strong adjectival inflection. I will not attempt to characterize the complete inventory of these rules here.

I briefly illustrate this proposal by discussing the derivation of the articleless masculine accusative singular DP in (22) above, repeated in (24a). In the case of (22), *v* is the case assigner that enters into Agree with both A and N. As a result of this, A is associated with the case feature of *v*, which is specified as accusative, with the gender feature of N, which is specified as masculine, and with the underspecified number feature of N (24b)²³. As in Chapter 4, feature sharing is indicated by indices on the attributes in the syntactic representation of the shared features. In the morpho-

²² I assume here that German articleless DPs that contain adjectives have a similar DP-structure as their Swedish counterparts. This means that they have a null D, which is internally merged because of the presence of the adjective.

²³ Note that I use here the syntactic feature representation I introduced in the previous section in which masculine is represented as [Gen: masc], accusative as [Case: acc], and singular of the number attribute without a value [#:].

logical component the feature specification of A is spelled as the strong adjectival ending *-en* as in (24c).

- (24) a. *kalt-en* *Wein* STRONG, ACC, MASC, SG
 cold-MASC.ACC.SG.STRONG wine
 'cold wine'

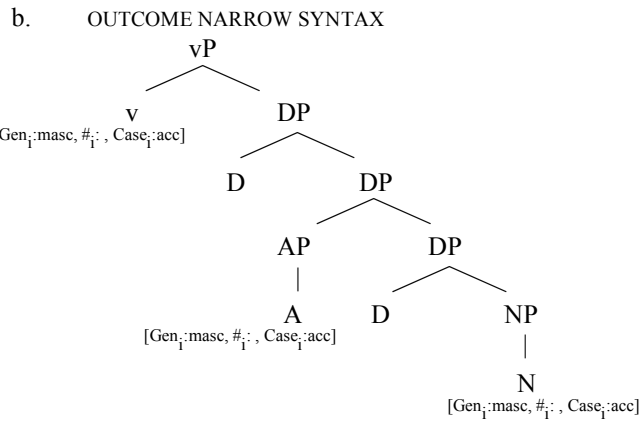

- b. VOCABULARY INSERTION
 A-[Gen: masc, #: , Case:acc] → *kalt-en*

Under my analysis, adjectives in German DPs without an article are thus always associated with the gender and number feature specification of N and to the case feature of the case assigner of the DP in question. I will now show that adjectives in German definite DPs are only associated with a subpart of these features.

5. Weak adjectival inflection

At first sight, weak adjectival inflection is radically different in German from that in Swedish and the other languages discussed in the previous chapter. In Swedish, weak adjectival inflection is invariant. Adjectives carrying weak inflection receive an ending that is independent of the gender and number of the noun they modify, as shown in the table in (25).

(25) WEAK ADJECTIVAL INFLECTION IN SWEDISH

Singular		Plural
Non-neuter	Neuter	
-a/-e ²⁴	-a/-e	-a/-e

²⁴ The choice between *-a* and *-e* depends on the adjective, not the gender and number specification of the noun.

In German, weak adjectival inflection is however not invariant. The ending that an adjective receives in the weak inflection can be either *-e* or *-en*, depending on the gender, number, and case of the head noun. This is illustrated in the table in (26), a repetition of the table in (4) above.

(26) WEAK ADJECTIVAL INFLECTION IN GERMAN

	Singular			Plural
	Masculine	Neuter	Feminine	
Nominative	-e	-e	-e	-en
Accusative	-en	-e	-e	-en
Dative	-en	-en	-en	-en
Genitive	-en	-en	-en	-en

Contrary to its Swedish counterpart, German adjectival inflection thus signals at least some case, gender and number distinctions via the opposition between the *-e* and *-en* endings. In recent years, numerous studies have discussed German weak adjectival inflection (see among others Kester (1996), Sauerland (1996), Schlenker (1999), Roehrs (2006, 2009), Leu (2008)). However, none of these studies accounts without stipulation for the gender and number distinctions signaled by the German weak adjectival inflection. The analysis of weak adjectival inflection that I proposed in the chapter 4 however gives a straightforward account of these distinctions.

In chapter 4, I showed that my analysis of weak adjectival inflection accounts for the invariance of the Swedish weak adjectival inflection through means of the deactivation of the definite D as a Probe. This deactivation was the result of Agree between D and N. Because of this deactivation, the licensing of gender and number distinctions on A via Indirect Agree is blocked. This analysis however also predicts that a particular distinction can be licensed on A in case the relevant probing feature is not deactivated on the definite D. In this section, I claim that this is exactly what happens in the case of German weak adjectival inflection. In other words, I argue that the distinctions in the German weak adjectival inflection are due to the fact that Agree between D and N does not deactivate all the probing features on D.

In order to show this, I first have to specify the distinctions that are made in the German weak adjectival inflection. If one abstracts away from the masculine, accusative, singular ending (more on this ending in section 5.5 below), there are two distinctions that are signaled by the German weak adjectival inflection: a case distinction and a number distinction. The case distinction is found in the singular part of the paradigm, see the table in (26). In the singular, structural, nominative and accusative, marked by *-e*, is distinguished from inherent case, dative and genitive, marked by *-en*.²⁵ The number distinction concerns the nominative and accusative cases. In these cases, singular number (*-e*) is distinguished from plural number (*-en*). Notwithstanding these two case and number distinctions, the majority of the dis-

²⁵ Following Bayer, Bader & Meng (2001), I will refer to nominative and accusative as structural case in German. I will use the term inherent case to refer to dative and genitive, instead of the term oblique case used in Bayer, Bader & Meng. I refer the reader to section 5.1.2 for the empirical reasons to distinguish nominative/accusative from dative/genitive in German.

tinctions signaled by the strong adjectival inflection are neutralized in the weak adjectival inflection. One can easily verify this by comparing the strong paradigm, repeated here in (27) with the weak paradigm in (26).

(27) STRONG ADJECTIVAL INFLECTION IN GERMAN

	Singular			Plural
	Masculine	Neuter	Feminine	
Nominative	-er	-es	-e	-e
Accusative	-en	-es	-e	-e
Dative	-em	-em	-er	-en ²⁶
Genitive	-en	-en ²⁷	-er	-er

First, unlike in the strong paradigm, gender distinctions are absent in the whole weak paradigm (I am still abstracting from the masculine accusative singular). Secondly, there is no difference in endings for dative and genitive case in the weak paradigm, while these cases are distinguished in the strong paradigm. Finally, the difference between singular and plural is unmarked in the dative and the genitive in the weak paradigm. Below, I will show that my analysis of weak adjectival inflection correctly predicts all these distinctions and neutralizations.

5.1. Singular

Above, I discussed which gender, number, and case distinctions are expressed by the weak adjectival inflection and which distinctions are not. In this subsection, I will examine the distinctions and the lack of distinctions in the singular part of the weak paradigm (see the table in (27) above). I first discuss the lack of gender distinctions. After that I take a closer look at the distinction between inherent and structural case. Finally, I examine why there is no distinction between dative and genitive case.

5.1.1. Gender neutralization

The strong adjectival inflection signals the gender of noun it modifies through different endings (see the table in (3) above). If one disregards the exceptional masculine accusative ending for now, the weak adjectival inflection does however not display gender distinctions.²⁸ Put differently, gender distinctions are neutralized in the weak adjectival inflection. In order to illustrate this, the nominative singular part of both the weak and the strong paradigm are reproduced in the table in (28).

²⁶ In the dative plural, the noun gets an -n suffix.

²⁷ In the genitive singular masculine and neuter, the noun gets an -(e)s suffix

²⁸ I will come back to the masculine accusative singular ending in section 5.5. In that section, I will show that this ending is radically different from the other endings in a number of ways.

(28) WEAK VS. STRONG ADJECTIVAL INFLECTION IN
GERMAN IN THE SINGULAR NOMINATIVE

	Masculine	Neuter	Feminine
Weak	–e	–e	–e
Strong	–er	–es	–e

In this part of the paradigm, the strong adjectival inflection has a different ending for each of the possible genders of the noun that is modified by the adjective. In the weak adjectival inflection, the ending in this part of the paradigm is always *–e*, independently of the gender of the noun.

In the weak adjectival inflection, gender is thus not morphologically realized, while it is in the strong adjectival inflection. This difference in morphological realization between strong and weak adjectival inflection only applies to masculine and neuter, not to feminine. As I showed in section 3 of this chapter, feminine gender is never morphologically realized, not even in the strong adjectival inflection. There is thus no difference between the strong and the weak adjectival inflection with respect to feminine gender. In both cases, gender is morphologically unrealized. From this perspective, it is unsurprising that the ending that occurs on adjectives modifying nominative singular feminine nouns in the strong paradigm is identical to that in the weak paradigm. This ending is *–e* as one can see in (28).²⁹ The thing that therefore needs to be explained is the absence of morphological realization of masculine and neuter in weak adjectival inflection. I claim that this absence can be related to the same cause as the absence of gender distinctions in the Swedish weak adjectival inflection. In chapter 4, I showed that my analysis of weak adjectival inflection attributes the gender neutralization in Swedish weak adjectival inflection to the deactivation of the definite D as a gender Probe as a result of Agree with N. This deactivation prevents the licensing of gender distinctions on A through Indirect Agree. I will now show in detail how this proposal carries over to German.

In chapter 2, I argued that the syntactic derivation of definite DPs is the same in Swedish and German. In both languages, adjectives are adjoined to DP triggering internal merge of D. This results in a DP-structure with two D-copies.³⁰ In addition, German definite Ds are Probes, just like their Swedish counterparts. German definite articles inflect for gender, number and case, as showed this in section 3 above with the help of the inflectional paradigm of the German definite article in the table in (14), repeated here in (29).

²⁹ It is not always the case that an ending that modifies a singular feminine noun is identical in the strong and weak paradigm. The dative and genitive endings are *–er* in the strong inflection and *–en* in the weak inflection. However, I will show below in section 5.1.2 that this is due to a difference in the realization of case, not gender. In this way, this difference in form between the strong and weak paradigm is not a counterargument to the claim that the feminine singular endings of the strong inflection do not differ with respect to the realization of gender from those of the weak inflection.

³⁰ The fact that Swedish spells out both these copies, resulting in double definiteness, while German does not, was attributed to a morphological difference between the two languages. This difference concerns the status of the definite article that spells out the definite D. In Swedish, the definite article is a suffix, while it is a free morpheme in German. I refer the reader to chapter 2 for a more detailed discussion.

(29) INFLECTION OF THE GERMAN DEFINITE ARTICLE

	Singular			Plural
	Masculine	Neuter	Feminine	
Nominative	der	das	die	die
Accusative	den	das	die	die
Dative	dem	dem	der	den
Genitive	des	des	der	der

The German definite D is therefore a gender, number and case Probe.

As in Swedish, the definite D in German therefore enters into Agree with N, just after D and N are merged. This results in D being associated with the gender feature of N via feature sharing, as in (30). In order to simplify the discussion, I abstract away from Agree for case and number for now. These will be discussed in separate sections below.

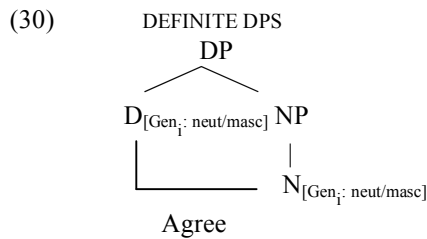

In section 3 of this chapter, I argued that masculine and neuter are syntactically represented in German as fully specified attribute-value pairs. These were [Gen: masc] for masculine and [Gen: neuter] for neuter. Agree between D and a neuter or masculine N therefore associates D with a full specification for gender. In chapter 4, I argued that Probes search for a Goal in order to specify underspecified features. Agree between D and N in (30) achieves this aim. Hence, D is deactivated as a gender Probe, just like in Swedish.

The next step after the deactivation of D as a gender Probe is to merge A as an adjunct to DP. Although it is a gender Probe (cf. the gender agreement on adjectives in the strong inflection), A fails to establish Agree with D and N, because the dominance requirement is not met. A does not dominate D and/or N. In addition, D also does not enter into Agree with A, because it was already deactivated as a gender Probe earlier on in the derivation by Agree, see (30). It is not the case that D does not enter into Agree with A because the dominance requirement is not met. After the adjunction of A to DP, a DP node dominates A. Under the label-sharing view of projection (see chapter 3), this is the same as D dominating A.

The next step in the derivation is that the definite D in German is internally merged at a position that is higher than the AP-adjunction site (see chapter 2), as in (31).

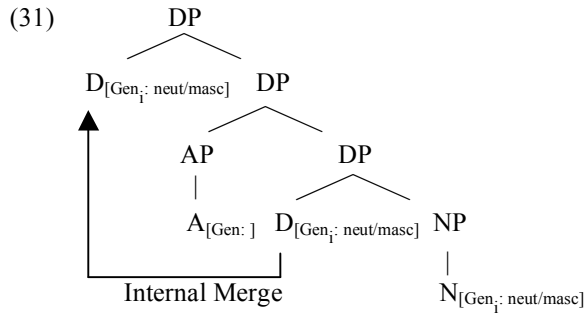

The internally merged D is an exact copy of the lower D. It is therefore already associated with the fully specified gender specification of N. It is thus not a gender Probe. As a consequence, the internally merged D does not establish Agree with A for gender. Moreover, it prevents any DP-external gender Probe, like for instance a case assigner, from doing so, as it always constitutes a closer Goal for such a Probe than A. This renders feature sharing between A and N as a result of Indirect Agree impossible. The gender specification on A therefore remains underspecified and unshared throughout the syntactic derivation. As a consequence, if N is neuter or masculine, A will not be specified for masculine or neuter at the outcome of narrow syntax. This is illustrated in (32b) for the masculine DP in (32a).

- (32) a. *der kalt-e Wein* WEAK, NOM., MASC., SG.
 the.NOM.MASC.SG cold-WEAK wine
 ‘The cold wine’
 b. OUTCOME NARROW SYNTAX

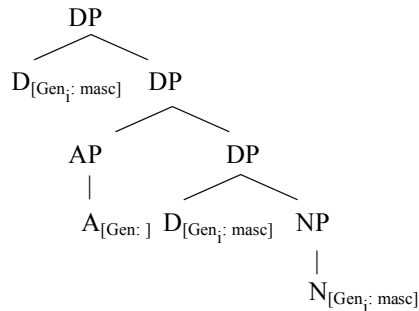

In this way, A never carries in German definite DPs a gender feature that is specified as neuter or masculine. As a result, masculine and neuter are not morphologically realized on adjectives in definite DPs. This explains the gender neutralization in the weak adjectival inflection in German in exactly the same way as in Swedish.

Above, I argued that feminine was uninteresting from the point of view of gender neutralization, since it is already morphologically unrealized in the strong adjectival inflection. Hence, there can be no contrast for feminine between the strong and weak inflection with respect to gender realization. However, I would like

to point out that the syntactic derivation of singular feminine definite DPs with an adjective is different from their neuter and masculine counterparts.

This difference is due to the fact that feminine is syntactically represented as a gender attribute without a value, i.e. feminine corresponds to underspecified gender (see section 3 above). When D enters into an Agree relation with a feminine N, it therefore is associated with an underspecified gender feature. This has the consequence that D is not deactivated as a gender Probe (cf. the definition of Probes in chapter 4), unlike in masculine and neuter DPs. This is schematized as *Agree 1* in (33).

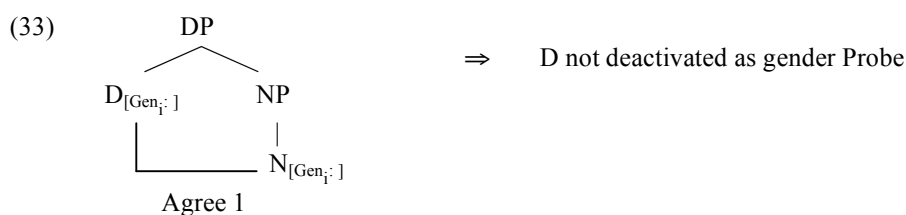

The fact that D is still an active gender Probe after Agree with a feminine N has as a consequence that D enters into an Agree relation with A. After it is merged as an adjunct, A is dominated by the DP-node. This node is a gender Probe for two reasons. First, it shares the same label as D, given the feature sharing view of projection (see chapter 3). Second, the Probing gender feature that is part of this label has not been deactivated as a gender Probe by Agree with N. A has an underspecified gender feature by the virtue of being a gender Probe itself. On the feature sharing view of Agree, underspecified features can be targeted as a Goal. As a consequence, an Agree relation is established between D and A. This Agree relation is indicated in (34) as *Agree 2*.

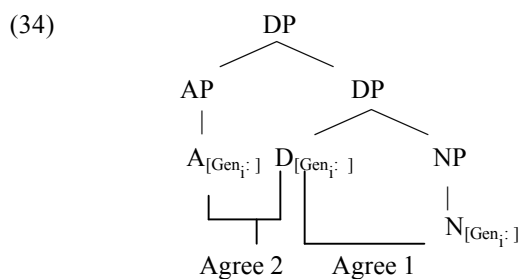

As a result of this instance of Agree, the underspecified gender specification of N is now shared between N, D, and A. This is indicated in (34) by coindexation. The next step in the derivation is to internally merge D. The D-copy that is created by this instance of internal merge is identical to the lower copy. It therefore already shares an underspecified feature with A, because of *Agree 2*, and with N because of *Agree 1*. There are therefore no elements with unshared gender features in the search domain of the higher D-copy. Hence, internal merge of D does not lead to new

Agree-relations. On the outcome of Narrow syntax, an adjective in a feminine definite DP thus shares [Gen:] with both D copies and N. This is illustrated in (35b) for the feminine DP in (35a).

- (35) a. *die* *kalt-e* *Wurst* WEAK, NOM, FEM, SG
 the.NOM.FEM.SG cold-WEAK sausage
 ‘the cold sausage’

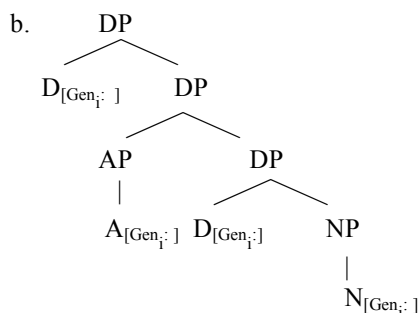

I take gender to be interpretable on N.³¹ Under CI-dependent SM-interpretation (see chapter 4), the sharing of underspecified gender feature between A and N in feminine definite DP therefore has as a consequence that A enters the SM-component with an underspecified gender feature. This is different from adjectives in definite DPs with a neuter or masculine noun. An A in these DPs also carries an underspecified gender by virtue of being a gender Probe. However, this feature is not shared with N on which gender is interpretable (see above). Given CI-dependent SM-interpretation, A enters in these cases the SM component of the grammar without a gender specification. This different specification for gender however does not lead to a different inflectional marker. As I argued in section 3, gender is not morphologically realized for feminine. Another way of putting this is that the [Gen:]-feature is not morphologically realized, because there is no morpheme in the vocabulary inventory of German that spells out [Gen:]. Hence, the *-e* ending which is not specified for gender is inserted on the adjective both in the definite DPs with a feminine noun and in those with a neuter or masculine noun.³² All this is schematized in the table in (36).

³¹ The interpretability of gender has something to do with categorizing objects (cf. Picallo 2005). See chapter 6 for more discussion.

³² Instead of gender, *-e* spells out other features. I will specify these other features in the following sections.

(36) FEATURE SPECIFICATION OF A IN GERMAN DEFINITE DPS

	Masculine	Neuter	Feminine
outcome Narrow Syntax	[Gen:]	[Gen:]	[Gen _i :] (shared with N)
SM-interface	[∅]	[∅]	[Gen:]
Vocabulary Insertion	-e	-e	-e

In this way, the different syntactic derivation of feminine definite DPs is without morphological consequences. Put differently, although the different derivation has as consequence that A is specified differently at vocabulary insertion in feminine definite DPs, there is no morpheme available to spell out this difference. Syncretism in the inventory of adjectival inflectional markers masks in this way a difference in the syntactic derivation. However, this is not always the case. Below in section 5.2., I will show that an identical difference in syntactic derivation, but then with respect to number instead of gender, does give rise to a different morphological realization.

The absence of gender distinctions in the weak adjectival inflection is thus explained under my analysis. The masculine and neuter feature specifications are not licensed on A in definite DPs, because D was deactivated as a gender Probe after agree with N. This was not the case in feminine definite DPs. Since German feminine is however not morphologically realized, this does however not lead to the marking of gender distinctions in the weak adjectival inflection. I will now turn to the case distinction in the weak adjectival inflection.

5.1.2. The structural vs. inherent case distinction

As mentioned above, the crucial difference between Swedish and German with respect to weak adjectival inflection is that weak adjectival inflection in German is not invariant. One of the distinctions expressed by weak adjectival inflection in German is found in the singular part of the paradigm. This distinction is the contrast between inherent and structural case. As can be seen in the table in (37), structural case, i.e. nominative and accusative, is marked by the ending *-e*, while inherent case, i.e. dative and genitive, is marked by the ending *-en*.³³

(37) GERMAN WEAK ADJECTIVAL INFLECTION (SINGULAR ONLY)

	Masculine	Neuter	Feminine
Nominative	-e	-e	-e
Accusative	-en	-e	-e
Dative	-en	-en	-en
Genitive	-en	-en	-en

³³ I am still abstracting from the accusative singular masculine ending.

Why does the weak adjectival inflection in German display this case distinction? In order to answer this question, the licensing differences between structural and inherent case must be taken into account.

In section 3 of this chapter, I showed that all four cases in German are morphologically realized. I therefore concluded that all of the four cases are syntactically represented as attribute-value pairs. These attribute-value pairs were given in the table in (21), repeated here in (38).

(38) CASE IN GERMAN

Interpretation	Syntactic Representation
'nominative'	[Case: nom]
'accusative'	[Case: acc]
'dative'	[Case: dat]
'genitive'	[Case: gen]

In section 4, I adopted Chomsky's (2001) proposal that case is assigned as a consequence of an Agree relation that is triggered by a case-assigning Probe. Bayer, Bader & Meng (2001), however, argue that this method of case assignment is limited to structural case. They claim that inherent case is assigned in a different way. They motivate this claim by showing that DPs carrying inherent case display a syntactic behaviour that differs in a number of ways from that of DPs carrying structural case. A secondary predicate for instance can be linked to a DP with a structural case, like the nominative *Hans* in (39a-b) or the accusative *Rektor* 'rector' in (39a).³⁴ It can however not be linked to a DP with inherent case, like the dative *dem Rektor* 'the rector' in (39b) (Bayer, Bader & Meng 2001: 486-487, citing Vogel & Steinbach 1995).

- (39) a. *Hans_i hat den Rektor_j schon dreimal betrunken_{i,j} getroffen.*
 Hans.NOM has the.ACC rector.ACC already three-times drunk
met
 'Hans_i has met the rector_j already three times while he_{i,j} was drunk'
- b. *Hans_i ist dem Rektor_j schon dreimal betrunken_{i/*j} begegnet.*
 Hans.NOM is the.DAT rector.DAT already three-times drunk
met.
 'Hans_i has met the rector_j already three times while he_{i/*j} was drunk'
 (Bayer et al. 2001: 486-487, ex 38)

In addition to secondary predication, Bayer, Bader & Meng (2001) show that DPs with inherent case differ from those with structural case with respect to phenomena as diverse as nominalization, extraction, binding possibilities and topic drop. They argue that all these differences are caused by the dissimilarity between the assignment of structural case and that of inherent case. They take structural case to be

³⁴ The relevant predication relations in (39) are indicated by means of the indices *i* and *j*.

assigned under agreement with DP-external case assigner, like T or v. This is similar to Chomsky's (2001) view on case licensing that I adopted. According to Bayer et al., inherent case is however specified inside the nominal domain. Inherent case is thus not assigned by a DP-external case licenser. I adopt these insights about the different ways in which inherent and structural case are assigned.

I implement this difference in the assignment of inherent and structural case by proposing that the case specification for N differs for structural and inherent case upon entering the syntactic derivation. In the case of structural case, N enters the derivation with an underspecified case feature, [Case:]. This feature will only be specified as the result of Agree with a Probe that has a specified case feature, i.e. a case assigner like T or v (cf. Chomsky 2001 and section 4 above). In the case of inherent case, N enters the derivation with a case feature that is specified for the relevant case, [Case: dat] for dative and [Case: gen] for genitive.³⁵ This difference in assigning inherent and structural case offers a straightforward explanation of the case distinction expressed in the weak adjectival inflection.

The difference between inherent and structural case has crucial consequences for the activeness of D as a case probe and therefore also for the specification of case on A. In the inherent cases, N has a case feature that is specified as genitive or dative. As a result, D will enter into Agree with N and share a case feature with N. As this case feature is fully specified, D is deactivated as a case probe. As a consequence, D will not enter into Agree with A for case, leaving the case feature on A unshared and underspecified throughout the syntactic derivation.

In the structural cases, by contrast, N has an underspecified case feature. Agree between D and N for case thus associates D only with an underspecified case feature. D therefore remains an active case Probe after Agree with N. As a consequence, it will enter into Agree with A for case. This results in an underspecified case feature that is shared between A, N and D. Agree with a DP-external case-assigning Probe then specifies this feature as either nominative or accusative. In this way, A is associated with a case feature that is specified as nominative or accusative. Under this analysis, A thus reaches the interfaces with an underspecified and unshared case feature if the definite DP carries dative or genitive case. If the definite DP carries however structural case, A is associated with a case feature that is specified for nominative or accusative and that is shared with D and N. The opposition between *-e* and *-en* in the singular part of the weak paradigm spells out this difference in case specification. I will now discuss this proposal in more detail.

I first examine the derivation of a definite DP carrying structural case. In order to simplify the discussion, I will abstract away from Agree-relations concerning other features than case. Consider for instance the nominative DP in (40).

³⁵ My implementation of the idea that inherent case is specified inside the nominal domain is slightly different from that of Bayer, Bader & Meng (2001). Bayer et al. propose that inherent case is introduced in the nominal domain with the help of an additional functional projection, KP. The head of this projection is specified for inherent case. For my account of the distinction between inherent and structural case, however, it does not matter whether the specification of inherent case enters the derivation on N or on a dedicated functional head (on the condition that functional head is lower than D). In order to not complicate the discussion with an additional functional projection, I diverge here from Bayer et al. and choose to do without KP.

- (40) *der kalt-e Wein* WEAK, NOM., MASC., SG.
 the.NOM.MASC.SG cold-WEAK wine
 ‘The cold wine’

As discussed above, N enters the derivation with an underspecified case feature when the DP will be marked nominative or accusative. Given that the DP in (40) is nominative, the N that will later be spelled out as *Wein* ‘wine’ thus carries a [Case:] feature at the beginning of the derivation. The first step is to merge N with the definite D. Considering that the German definite article inflects for case (see the table in (29) above), German definite Ds are case Probes. N has a case feature, although an underspecified one. D hence enters into an Agree relation with A for case. This results in the sharing of an underspecified case feature between D and N, as in (41a). Given that Agree does not associate D with a fully specified case feature, D remains an active case Probe. The next step is to merge A as an adjunct to DP. A is a case probe (see section 4 of this chapter). Because of its adjuncthood, A does not dominate any potential Goal, like D or N. That being the case, A does not trigger Agree. However, adjoining AP to DP causes AP to be dominated by a DP-node. Being part of the projection of D, this node shares its label with D. After Agree with N, D is still an active case Probe. Hence, the DP-node that dominates AP is also a case Probe. A carries an underspecified case feature, because it is also a case Probe itself. Under the feature sharing view, Agree can target an underspecified feature (see chapter 4). Therefore, Agree is established between DP and A. This results in the sharing of an unvalued case feature between A, D and N, as in (41b).³⁶

- (41) a. AGREE (D(P), N(P)) b. AGREE (D(P), A(P))
-

The next step in the derivation is internal merge of D, triggered by the adjunction of AP to DP (see chapter 2 for details), as in (42).

³⁶ Strictly speaking, Agree is established between the node of the projection of D that dominates NP/N, i.e. DP, and NP/N in (41a) and between the node of the projection of D that dominates AP/A, i.e. the highest DP node, and AP/A in (41b). Nevertheless, I indicated in (41) that Agree takes place between the terminal nodes, D and N in (41a) and D and N in (41b) in order to simplify the representations. This simplification has no effect on the outcome of Agree. Under the label-sharing view of projection that I advocated in chapter 3, Agree between non-terminal nodes of two different projections has the same outcome as Agree between the two terminal nodes of the projections in question. In both cases, the label that is shared between all the nodes of one of the two projections shares one of its features with the label that is shared between all the nodes of the other projection.

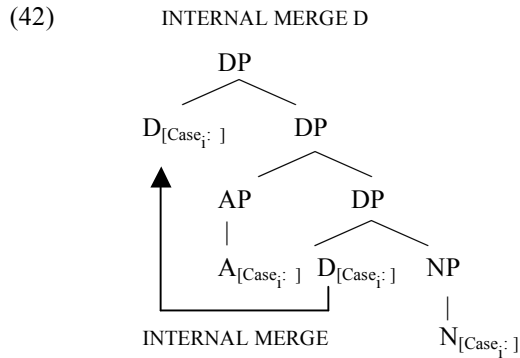

The higher D-copy that is created by this instance of internal merge is identical to the lower D-copy. As such, it is also associated with the unvalued case feature that was already shared between, A, the lower D and N. The higher D-copy thus has no elements in its search domain that have a case-feature to which it is not yet associated. Hence, internal merge of the higher D-copy does not trigger any new instances of Agree.

Later on in the derivation, T, the head that licenses the nominative case, is merged. This head is a phi-Probe. The first head that has these phi-features in T's search domain is the higher D-copy. T therefore enters into Agree with this D-copy. As a side effect of this instance of Agree, the underspecified case-feature of the higher D-copy is specified as nominative. The higher D however shares its case feature with A, the lower D and N. Therefore, these nodes are also associated with a case feature that is specified as nominative, as in (43).

(43) AGREE (T(P), D(P))

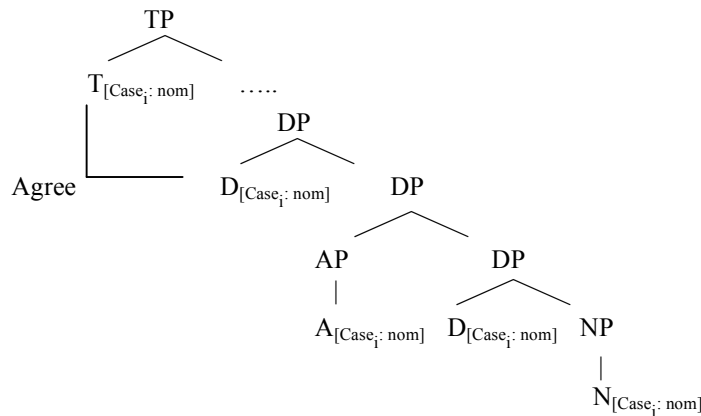

In this way, the underspecification of structural case on N ensures that A is eventually associated with a case feature that is specified as nominative or accusative.

I will now examine the derivation of DPs with inherent case. In order to do so, I will provide a detailed derivation of the dative definite DP in (44).

- (44) *dem kalt-en Wein* WEAK, DAT, MASC., SG.
 the.NOM.MASC.SG cold-WEAK wine
 ‘The cold wine’

As I discussed above, N enters the derivation with a fully specified case feature, in case DP is marked with inherent case. In the derivation of (44), N therefore starts the derivation carrying a case feature that is specified as dative, i.e. [Case: dat]. After the definite D is merged, D enters into Agree with N for case, just like in DPs with structural case. This results in D and N sharing the case feature specified as dative. This is shown in (45a). Unlike in (41a), Agree in (45a) deactivates D as a case probe. The reason for this is that after Agree, D is associated with a fully specified case feature. Hence, there is no longer a need for D to search for a case Goal that can specify its case feature. The consequences of the deactivation of D as a case Probe are similar to those of the deactivation of D as a gender probe in section 5.1.1. After the adjective is adjoined to DP, D does not enter into Agree with A for case because of its deactivation. This leaves A with an unshared and underspecified case feature. This situation is not changed by the subsequent internal merger of D. The higher D that is created by this instance of internal merge, is an exact copy of the lower D. By virtue of this, it is already associated with [Case: dat]. It is therefore a deactivated case Probe, just like the lower D. For this reason, it will not enter into Agree with A. This is shown in (45b). Note that the higher D-copy will also prevent any higher case Probe from entering into Agree with A, because D always constitutes a closer Goal for such a Probe.

- (45) a. AGREE (D(P), N(P)) b. INTERNAL MERGE D, D-INACTIVE FOR PROBING, CASE-FEATURE A(P) UNSHARED

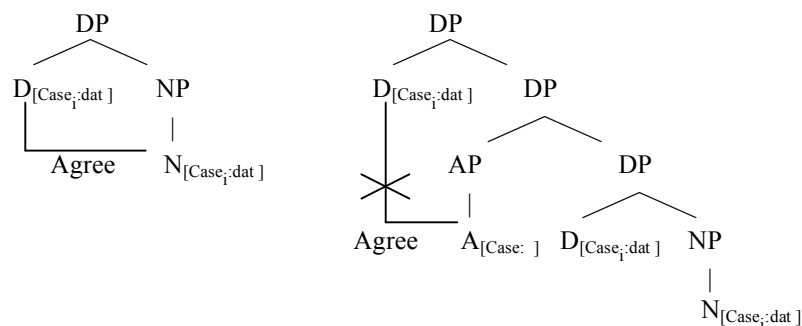

In this way, an adjective in a German definite DP with inherent case does not enter into an Agree relation for case. It therefore leaves the syntactic component of the grammar with an unshared and underspecified case feature.

This is crucially different from its counterpart in definite DPs with structural case. In these DPs, A reaches the interfaces with a specified gender feature that it shares with the case assigning head, the two D-copies and N. This difference in case specification has consequences at the SM-interface. In DPs with inherent case, the unshared and underspecified case feature of A is deleted at the SM-interface, because it is not associated with a position on which it is CI-interpretable (see the CI dependent SM-interpretation principle in the previous chapter).³⁷ The consequence of this deletion is that A enters the morphological component of the grammar without a specification for case. Therefore, the inflection on the adjective is spelled out by the elsewhere morpheme *-en*. This is summarized in the central column in the table in (46). In definite DPs with structural case, A shares with N a case feature that is specified as nominative or accusative. I assume that there is at least some aspect of case that is CI-interpretable on N. Given that it is shared with N, the case specification of A in definite DPs with structural case is interpretable at the SM-interface, because of CI-dependent SM-interpretation. In definite DPs with structural case, the case specification on A thus enters into the morphological component. In this component, this case feature, which is specified as nominative or accusative, is realized as the *-e* ending. This is summarized in the rightmost column of the table in (46).

(46) CASE ON A IN DEFINITE DPS WITH INHERENT OR STRUCTURAL CASE

	Inherent case	Structural case
Output narrow syntax	[Case:] (unshared)	[Case; nom/acc] (shared)
SM-interface	[∅]	[Case: nom/acc]
Vocabulary Insertion	<i>-en</i>	<i>-e</i>

Under my analysis, the lack of distinctions in weak adjectival inflection is attributed to the deactivation of D as a Probe. Above, I therefore claimed that my analysis of weak adjectival inflection predicts that weak adjectival inflection should display distinctions in case Agree does not deactivate D as a Probe. The above account of the distinction between structural and inherent case shows that this prediction is borne out. In definite DPs with structural case, D is not deactivated for case after Agree with N. As a consequence, structural case is licensed on A. In definite DPs with inherent case, D is deactivated and case is not licensed on A. In this way, the distinction between inherent and structural case in German weak adjectival inflection depends on whether D is deactivated or not as a case Probe.

³⁷ Even if it were shared between A and an element on which case is in principle interpretable, the underspecified case feature would still be deleted at the SM-interface. This is so because the different cases of German are mapped onto attribute-value pairs, given morpho-driven feature representation (see section 3 of this chapter). Hence no case interpretation is mapped onto an attribute lacking a value. Hence, a case attribute without a value is uninterpretable at the CI-interface, no matter which element it is associated with. Under CI-dependent SM-interpretation, an underspecified case feature is therefore deleted at the SM-interface.

5.1.3. Dative and Genitive neutralization

Not all case distinctions that are found in the strong adjectival inflection are also found in the weak adjectival inflection. In the strong adjectival inflection, dative case is distinguished from genitive case by different endings, as one can see in the table in (47). In the weak adjectival inflection, this distinction is not expressed. The weak adjectival inflection in a dative DP is identical to the one in a genitive DP. In both cases, the ending is *-en*, as one can see in the table in (48).

(47) STRONG ADJECTIVAL INFLECTION IN GERMAN: DATIVE & GENITIVE

	Singular			Plural
	Masculine	Neuter	Feminine	
Dative	-em	-em	-er	-en
Genitive	-en	-en	-er	-er

(48) WEAK ADJECTIVAL INFLECTION IN GERMAN: DATIVE & GENITIVE

	Singular			Plural
	Masculine	Neuter	Feminine	
Dative	-en	-en	-en	-en
Genitive	-en	-en	-en	-en

The absence of a distinction between genitive and dative in the weak adjectival inflection follows directly from the account of inherent case given above in section 5.1.2. In that section, I argued that N is fully specified for inherent case when it enters the derivation. As a consequence, the definite D is deactivated as a case Probe after Agree with N. It can therefore not enter into Agree with A for case. In this way, no case specification is licensed on A in case N is dative or genitive. If dative or genitive case is not licensed on A in syntax, it can also not be realized in the morphology. The absence of distinction between genitive and dative case in the weak adjectival inflection therefore follows from my account of the distinction between structural and inherent case.

5.2. Plural

Above, I discussed the singular part of the weak adjectival inflection in German. I will now extend the discussion and also consider the plural part of the paradigm. For the singular, I gave an account for the distinction between inherent and structural case, the absence of gender distinctions, and the absence of a distinction between genitive and dative. If the plural is also taken into account, some other patterns need to be explained as well. Reconsider for instance the complete paradigm of weak adjectival in German. This paradigm was given in the table in (4) above and is repeated here in (49).

(49) WEAK ADJECTIVAL INFLECTION IN GERMAN

	Singular			Plural
	Masculine	Neuter	Feminine	
Nominative	–e	–e	–e	–en
Accusative	–en	–e	–e	–en
Dative	–en	–en	–en	–en
Genitive	–en	–en	–en	–en

As already mentioned above, one of the most striking things about the paradigm in (49) is that there is a number distinction in the nominative and accusative. In the plural, the ending is *–en*, while in the singular it is *–e*.³⁸ There is no similar number distinction in the dative and genitive. In these cases, the ending is *–en* both in the singular and in the plural. Furthermore, the plural does not display a distinction between inherent and structural case, unlike the singular.

Despite the fact that the opposition between the endings *–e* and *–en* signals a number distinction, the *–e* ending is not marked for singular and the *–en* ending not for plural. As can be seen in the table in (49), *–en* occurs not only in the plural, but also in the inherent cases in the singular. As such, it cannot be specified as plural. In the strong adjectival inflection, the *–e* ending occurs in the plural, as in (50).

- (50) a. *gut-e Wein-e* b. *gut-e Bier-e*
 good wine.MASC-PL good beer.NEUT -PL
 ‘good wines’ ‘good beers’

Given that it also occurs in the plural, the *e*-ending cannot be specified as singular (see also section 3 above). The number distinction in the weak adjectival inflection is therefore not a reflection of morphological realization of either singular or plural. Instead, I claim that this distinction arises as the result of an interaction between the syntactic representation of German number proposed in section 3 of this chapter and my analysis of weak adjectival inflection.

Above, I showed that the level of specification of a particular feature on N has consequences for whether Agree can license this feature on adjectives in definite DPs. In case a particular feature is fully specified on N, Agree deactivates D as a Probe with respect to that feature. As a consequence, D cannot establish Agree with A for the feature in question. In that case, the relevant feature is not licensed on the adjective. If, on the other hand, N is underspecified for a particular feature at the start of the syntactic derivation, Agree does not deactivate D as a Probe with respect to that feature. In that case, D will enter into Agree with A for that feature. This licenses the feature in question on the adjective. In section 5.1.2, I used these differences to explain the distinction between inherent and structural case that is expressed in the singular part of the weak adjectival inflectional paradigm. I will now show that the number distinction can also be accounted for along these lines.

³⁸ I am still ignoring the masculine accusative, singular ending in the present discussion, but see section 5.5 below.

In section 3 of this chapter, I argued that singular and plural differ in German with respect to the level of specification of their syntactic representation. Singular number is syntactically represented as a number attribute without a value ($[\#:]$), i.e. as an underspecified number feature. Hence, when it enters into an Agree relation with a singular N, the definite D is not deactivated as a number Probe. When the adjective is subsequently adjoined to DP, D is still a number Probe. It will therefore enter into an Agree relation with A for number. This results in A sharing an underspecified number feature with N in a definite DP, as in (51a).

With respect to plural number, I argued that it is syntactically represented as a number attribute with a plural value ($[\#: pl]$), i.e. as a fully specified number feature. When it enters into Agree with a plural N, the definite D is therefore associated with a fully specified number feature. For this reason, it is deactivated as a number Probe. After A is adjoined to DP, D can therefore not enter into Agree with A for number. As a result, A will not share a number feature with N in a definite DP, as in (51b).

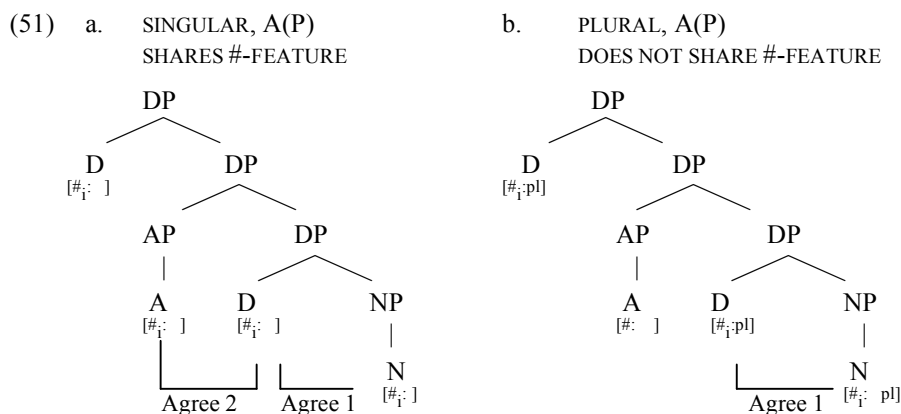

At the end of the syntactic derivation, A in a singular definite DP shares in this way an underspecified number feature with N. Although A in a plural definite DP also has an underspecified number feature by virtue of being a number Probe, this number feature is not shared with N. Under CI-dependent SM-interpretation, a feature must be CI-interpretable at one of the positions it is associated with, in order for it to be interpreted at the SM-interface at any of the positions it is associated with (see chapter 4). Given that number is not CI-interpretable at A, the underspecified number feature of A in plural DPs is deleted at the SM-interface. As a consequence, adjectives in plural DPs enter the morphological component without a number specification.

This is not the case for adjectives in singular DPs. Number is CI-interpretable at N. A in a singular DP shares an underspecified number feature with N. Hence, the underspecified number feature of A is interpretable at the SM-interface. Contrary to their counterparts in plural DPs, adjectives in definite singular DPs thus enter the morphological component with a number feature, albeit an underspecified one. These number specifications of adjectives on the output of narrow syntax and after

interpretation by the SM-interface are given in the table in (52) for both singular and plural definite DPs.

(52) NUMBER SPECIFICATION ON A IN THE GERMAN WEAK INFLECTION

	Singular DP	Plural DP
Output narrow syntax	[#:] (shared with N)	[#:] (unshared)
SM-interface interpretation	[#:]	[∅]

In this way, adjectives in singular definite DPs carry an underspecified number feature in the morphological component, while their counterparts in plural definite DPs do not carry a number feature in the morphological component. This difference in number specification is morphologically encoded in the nominative and accusative as the distinction between the *-e* ending and the *-en* ending. I will come back below to the exact feature specification of these endings.³⁹

In this way, the number distinction in the weak adjectival inflection follows from the syntactic representation of singular and plural number in German as determined in section 3 of this chapter and my analysis of the strong-weak distinction.

5.3. The complete weak paradigm: VI-rules

In the previous sections, I concluded that only a subset of the features of N can be licensed on adjectives in German definite DPs, via Agree, i.e. feature sharing. Adjectives in definite DPs only share a case, number, or gender feature with N if the relevant feature is underspecified at the start of the derivation. I will now discuss how the features that are licensed on adjectives in definite DPs are morphologically realized as adjectival inflection. However, before doing so, I first have to combine the results of the previous sections. This is necessary because in these sections I examined gender, number, and case in isolation. However, these features are not realized separately on the German adjective. Instead, the German adjectival inflection consists of a portmanteau morpheme that simultaneously realizes the gender, number, and case specification of the adjective.

In order to combine them, I will first briefly summarize the conclusions of the previous sections. As far as gender is concerned, an underspecified gender feature, [Gen:], is licensed on the adjective if the noun is feminine. In all other

³⁹ Note that the difference in number specification of A between singular and plural definite DPs in the morphological component is parallel to the difference in gender specification of A between feminine definite DPs and masculine/neuter definite DPs, which was discussed in section 5.1.1. On the one hand, A in feminine definite DPs carries an underspecified gender feature, just like A carries an underspecified number feature in singular definite DPs. On the other hand, A is not specified for gender at all in the morphological component in case it occurs in a masculine or neuter definite DP, just like it is not specified for number in plural definite DPs. The two cases are however different with respect to morphological realization. In the gender case, the difference in specification is not morphologically realized, while it is realized as the *-e* vs. *-en* opposition in the number case.

cases, no gender features are licensed on the adjective (see section 5.1.1 above). With respect to case, a case feature that is specified as nominative or accusative is licensed if the definite DP bears nominative or accusative case. However, no case specification is licensed on the adjective if the definite DP carries dative or genitive case (see section 5.1.2-5.1.3 above). Finally, an underspecified number feature is licensed on the adjective in singular definite DPs, but no number feature is licensed if the definite DP is plural (see section 5.2 above). In the table in (53), these results with respect to the feature specification of adjectives in definite DPs are combined. The grey cells in (53) indicate the gender, number and case features of the definite DP in which the adjective is contained. The feature specification between brackets is the feature specification of the adjectives after they are submitted to the SM-interface.

(53) FEATURE SPECIFICATION ON ADJECTIVES IN DEFINITE DPS AT THE SM-INTERFACE

	Singular			Plural		
	Masc	Neut	Fem	Masc	Neut	Fem
Nom	[Case: nom], [#:]		[Gen:], [Case: nom], [#:]	[Case: nom]		[Gen:], [Case: nom]
Acc	⁴⁰	[case: acc] [#:]	[Gen:], [Case: acc], [#:]	[Case: acc]		[Gen:], [Case: acc]
Dat	[#:]		[Gen:], [#:]	[∅]		[Gen:]
Gen						

The feature specifications in (53) are mapped in the morphological component onto the two adjectival endings that occur in the weak adjectival inflection: the *-e* ending and the *-en* ending. The *-e* ending occurs on adjectives in singular definite DPs with structural case. As one can see in the table in (53), these adjectives set themselves apart from the other adjectives in that they carry in the morphological component both an underspecified number feature and a case feature that is specified as nominative or accusative. Adjectives in other definite DPs either lack one of these features or both. Therefore, the *-e* ending simultaneously realizes an underspecified number feature and a case feature that is specified as nominative or accusative. This conclusion is schematized in (54a) as Vocabulary Insertion Rule A. In the cases in which the *-e* ending does not occur, the *-en* ending occurs on the adjective. The *-en* ending does not realize any gender, number, case specification on the adjective, because it also occurs on adjectives in plural masculine or neuter DPs with inherent case. As one can see in the table in (53), these adjectives are not specified at all for case, gender, and number. Put differently, the *-en* ending is the elsewhere morpheme, i.e. the morpheme that does not realize any features and that only shows

⁴⁰ Since I excluded the singular masculine accusative weak ending from the present discussion, I do not specify its feature specification in the table in (53).

up if a more specific morpheme cannot. This conclusion is schematized as Vocabulary Insertion Rule B in (54b).

- (54) VOCABULARY INSERTION RULES GERMAN WEAK ADJECTIVAL INFLECTION:
- a. Rule A: A-[#: , Case: nom/acc] → A-*e*
- b. Rule B: A-[∅] → A-*en* (elsewhere rule)

The two VI-rules in (54) map the feature specifications in (53) onto the *-e* and *-en* ending. This yields the weak adjectival paradigm, as in the table in (55).

- (55) MORPHOLOGICAL REALIZATION OF THE GENDER, NUMBER AND CASE SPECIFICATION OF ADJECTIVES IN DEFINITE DPs.

	Singular			Plural		
	Masc	Neut	Fem	Masc	Neut	Fem
Nom	<i>-e</i>			<i>-en</i> (VI-rule B)		
Acc	(VI-rule A)					
Dat						
Gen						

Under this account, the distinctions in German weak adjectival inflection arise because the structural description for VI-rule A is only satisfied in definite DPs in case DP is singular and carries structural case. Only then does the adjective carry at Vocabulary Insertion both an underspecified number feature (see section 5.2) and a case feature that is specified as nominative or accusative (see section 5.1.2). In these DPs, VI-rule A realizes the adjectival inflection as *-e*. In all other cases, the feature specification of the adjective does not meet the structural description of VI-rule A. In plural definite DPs, no number feature is licensed on the adjective (see section 5.2). In DPs with inherent case, no case feature is licensed on the adjective (see section 5.1.2). Hence, the elsewhere VI-rule B applies, spelling out the adjectival inflection as *-en*. This accounts for the distinction between structural (*-e*) case and inherent case (*-en*) in the singular, as well as for the distinction between singular (*-e*) and plural (*-en*) in the structural cases.

The two VI-rules in (54) do not only account for the distinctions expressed in the German weak adjectival inflection. They also offer an explanation for the absence of some distinctions that might be expected on the basis of the syntactic analysis that I presented of weak adjectival inflection. As mentioned above, the plural part of the weak paradigm does not express a distinction between inherent and structural case. Put differently, the ending of the adjective in plural definite DPs is always *-en*, irrespective of the case DP carries (see the table in (55)). This is unexpected if only the syntactic part of my analysis is taken into account. As shown in section 5.1.2, there is a difference between adjectives in definite DPs with structural case and those in definite DPs with inherent case. The former enter the morphological component bearing a case feature that is specified for nominative or accusative, while the latter do not carry a case feature. However, this difference does not matter for morphological realization, given the two VI-rules in (54). Since adject-

tives in plural definite DPs lack a number feature at Vocabulary Insertion (see section 5.2) irrespective of the case of DP, VI-rule A cannot apply at all in plural definite DPs. Instead, the elsewhere VI-rule B applies both in plural definite DPs with structural case and in those with inherent case. Put differently, adjectives in plural definite DPs with structural case enter the morphological component with a feature specification that is different from that of their counterparts in plural definite DPs with inherent case. However, German lacks the morphological means to spell out this difference.

The same goes for the absence of a number distinction in the weak adjectival inflection for the inherent cases. Both in singular definite DPs with inherent case and in plural definite DPs with structural case, the ending for the adjective is *-en* (see the table in (55)). Under the analysis presented in section 5.2, the adjectives in these two types of DPs are different at Vocabulary Insertion. Adjectives in singular definite DPs carry an underspecified number feature, while those in plural definite DPs do not bear a number feature. However, VI-rule B applies in both cases, given the lack of case features on the adjective in both cases. Again, there is a difference in feature specification, but the morpheme inventory of German is not rich enough to spell out this difference.

A couple of remarks are in order with respect to VI-rule A in (54), repeated here in (56).

(56) VI-Rule A: A-[#: , Case: nom/acc] → A-*e*

First, VI-rule A does not contradict the observation that the *-e* ending also occurs in the plural of the strong adjectival inflection (see sections 2 and 4 of this chapter). The occurrence of the *-e* ending in the plural was illustrated in (50), repeated here in (57).

(57)	a.	<i>gut-e</i> <i>Wein-e</i>	b.	<i>gut-e</i> <i>Bier-e</i>
		good wine.MASC-PL		good beer.NEUT-PL
		‘good wines’		‘good beers’

Under my analysis of strong adjectival inflection (see section 4 of this chapter), adjectives in DPs without articles share case, gender and number features with N. As a consequence, the adjectives in (57) reach Vocabulary Insertion with a number feature that is specified as plural ([#: pl]). By contrast, the *-e* ending realizes only an underspecified number feature ([#:], according to VI-rule A in (56). However, this renders the *-e* ending not incompatible with an adjective that is specified as plural. Under the subset principle (Halle 1997, see chapter 4), a morpheme that spells out only part of the feature specification of a terminal node can be inserted at that terminal node, as long as there is no morpheme available that realizes more properties of that feature specification. A morpheme that realizes only the number attribute [#:], like *-e*, can therefore be inserted at a node that carries a number attribute with a plural value [#: pl], as long as there is no morpheme available that realizes [#: pl]. This is the case for the strong adjectival inflection. The *-e* ending that only realizes [#:], is inserted in case the adjective reaches Vocabulary Insertion while being specified as [#:pl] and [Case: nom/acc]. This is the case in (57). This is

rendered possible by the absence of a strong adjectival ending that realizes [#: pl] from the morpheme inventory of German.

The second remark with respect to VI-rule A is that it is crucial to the present analysis that only those features that participate in an Agree relation are interpreted at the SM-interface, as I proposed in chapter 4. Adjectives always carry an underspecified number feature in narrow syntax by virtue of being a number Probe (see chapter 4). As shown in section 5.2, adjectives in singular definite DPs differ from those in plural definite DPs in that they share their underspecified feature with N as a result of Agree. If underspecified features were always interpreted at the SM-interface irrespective of whether they participated in an Agree relation, adjectives in singular definite DPs and those in plural definite DPs would both carry an underspecified number feature at Vocabulary Insertion. In that case, VI-rule A would apply in both cases, spelling out the inflection on the adjective as *-e*. However, this is contrary to fact. Adjectives in plural definite DP take the default *-en* ending (see the table in (55) above). If, on the other hand, the interpretation of underspecified features at the SM-interface depends on whether these features participated in Agree or not in the way described in chapter 4, the absence of the *-e* ending in the plural part of the strong paradigm can be accounted for as in section 5.2. The underspecified unshared number feature on A in plural definite DPs is deleted at the SM-interface, while its shared counterpart in singular definite DPs is interpreted at the SM-interface. As a result, VI-rule A only applies in singular definite DPs, not in plural ones. This accounts for the absence of the *-e* ending in plural definite DPs. In this way, my analysis of the number distinction in German weak adjectival inflection supports the SM-interface condition introduced in chapter 4.

5.4. Illustration of the account for German weak adjectival inflection

In order to illustrate some of the aspects of the proposals made in the previous sections, I will provide below the derivations of two definite DPs. I will consider two different DPs. I will start with the derivation of an accusative, neuter, singular DP. I will then proceed with the derivation of a plural, dative DP.

5.4.1. Singular neuter accusative DP

In this section, I examine the derivation of the singular neuter DP in (58). The DP in (58) can either be nominative or accusative. In the derivation that follows, I take the DP to carry accusative case.

- (58) *das* *kalt-e* *Bier* WEAK, ACC, NEUT, SG
the.NOM/ACC.NEUTER.SG cold-WEAK beer
‘the cold beer’

The derivation of the DP in (58) allows me to illustrate three different aspects of the account that I presented in sections 5.1 and 5.2. First, it illustrates the manner in

which a case feature that is specified as nominative or accusative is licensed on adjectives in DPs with structural case (see section 5.1.2). Secondly, it exemplifies the way in which an underspecified number feature is licensed on adjectives in singular definite DPs (see section 5.2). Finally, it illustrates the claim that no gender feature is licensed on the adjective in neuter definite DPs (see section 5.1.1).

The first step in the derivation of the DP in (58) is to merge the definite D with N, as in (59).

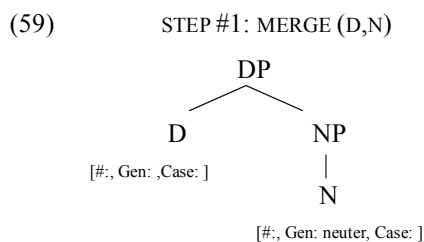

Given that definite Ds are case, gender, and number Probes in German (see section 5.1.1 of this chapter), D enters the derivation with underspecified gender, number, and case features. In accordance with the syntactic representation of gender and number in German that I presented in section 3 of this chapter, the singular neuter N carries an underspecified number feature and a gender feature that is specified as neuter. Above, I adopted the view that N starts out the derivation with an underspecified case feature if DP receives structural case (see section 5.1.2 above). Given that I take the DP in (58) to carry accusative case, N therefore also carries an underspecified case feature in (59).

The next step in the derivation is Agree between D and N. As a result of this, D and N share the case, gender, and number features that originated on N. This is illustrated in (60).

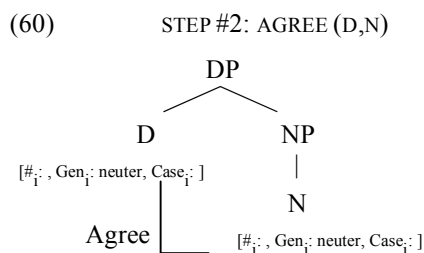

As a result of Agree between D and N, D is associated with the gender feature of N that is specified as neuter. Given that this feature is fully specified, D is deactivated as a gender Probe. This blocks D from entering into new Agree relations concerning gender. Agree also associates D with the number and case feature of N. However, D is not deactivated as a number and case Probe, because these features are underspecified on N.

After Agree between D and N, the adjective is merged as an adjunct to DP, as in (61).

(61) STEP #3: MERGE (AP, DP)

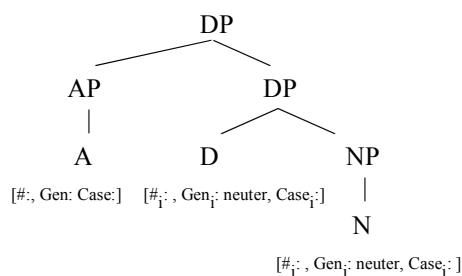

Attributive adjectives in German are Probes for number, gender and case (see section 4 above). They therefore enter the derivation with underspecified gender, number and case features. Despite its probeness, the adjective does not trigger Agree, because none of the nodes associated with the label of A dominates a suitable Goal. Hence, the dominance requirement is not met.

However, adjoining the adjective to DP results in the adjective being dominated by a DP node. This node shares its label with D (see the label-sharing view of projection proposed in chapter 3). Agree in (60) above only deactivated the probing gender feature in the label of D, not the probing number and case features. Hence, the DP-node dominating A is an active number and case Probe. The adjective has underspecified number and case features by virtue of being a Probe for these features. It can therefore also be targeted as a Goal by another Probe. As a consequence, the DP-node that dominates A enters into an Agree relation with A for number and case. This is shown (62).⁴¹

(62) STEP #4: AGREE(D, A)

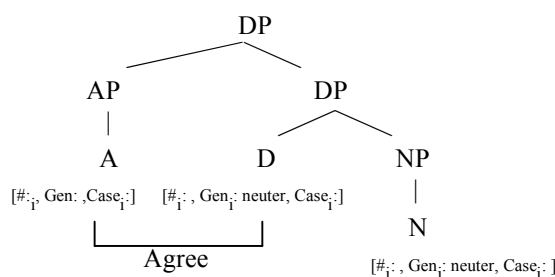

⁴¹ Agree in (62) is indicated between the terminal nodes D and A. I did this to not needlessly complicate the structure. However, it is contrary to what I actually consider to take place. I take Agree to be established between the DP node that dominates the adjective and the highest node of the adjectival projection. On the label-sharing view of projection, the result of Agree between two non-terminal nodes of different projections is the same as that of Agree between the two terminal nodes of that projection. Hence, the simplification in (62) can be made without consequence for the remaining part of the derivation.

As a consequence of Agree in (62), the adjective shares underspecified number and case features with D and N. The underspecified gender feature of the adjective is not targeted by Agree and therefore remains unshared.

The next step in the derivation is internal merge of D, as in (63). This step is triggered by the adjunction of the adjective to DP (see chapter 2 for a full discussion).

(63) STEP #5: INTERNAL MERGE OF D

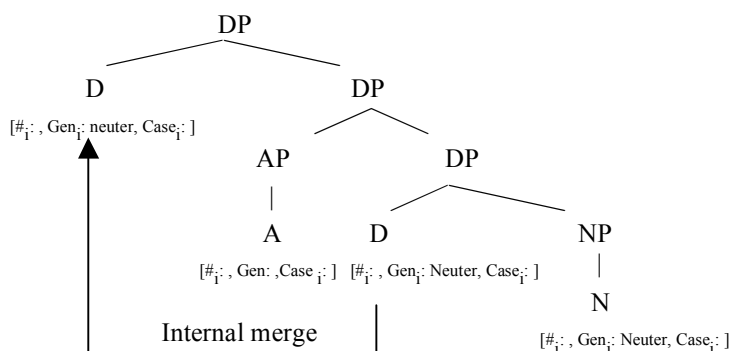

The higher D-copy that is created by this instance of internal merge is an exact copy of the lower D-copy. It therefore shares a gender feature that is specified as neuter with D and N. In addition, it shares underspecified number and case features with A, the lower D and N. By virtue of this, it is a number and case Probe. However, no new Agree relations are established after internal merge of D, because all elements that are endowed with number and case features in the search domain of the higher D (A, lower D, N) already share these features with the higher D because of earlier instances of Agree.

The derivation then continues until the case assigning head is merged. In the case of the accusative DP in (58), this case assigning head is v , like in (64).

(64) STEP #6: MERGE (v, DP)

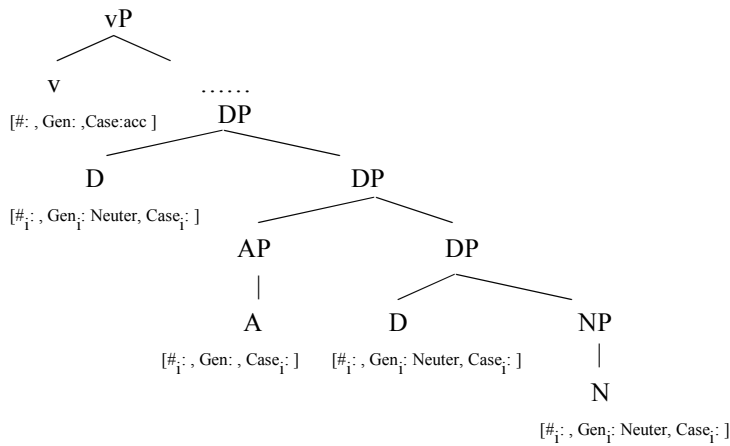

Under Chomsky’s (2001) view on case assignment, case assigning heads are phi Probes. Hence, *v* is a number and gender Probe.⁴² It will therefore scan its search domain for these features. It will find these features on the higher D-copy. *v* will therefore enter into an Agree relation with this higher D-copy, as in (65).

(65) STEP #7: AGREE (v, D)

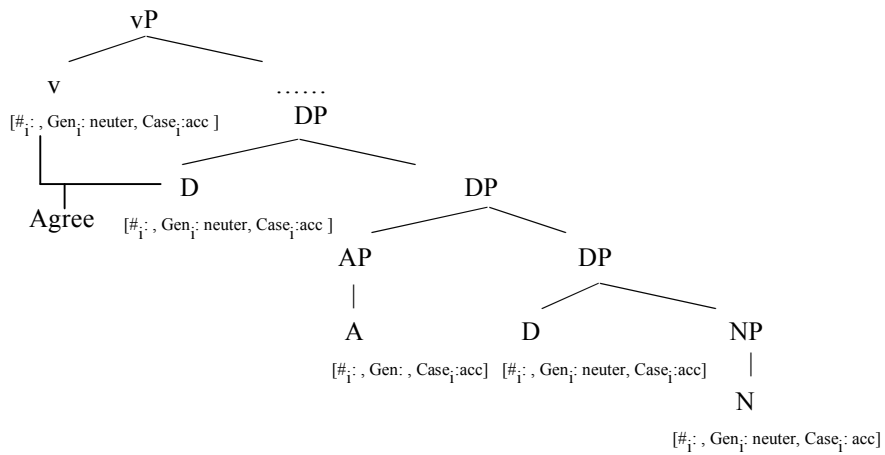

⁴² Maybe it is also a person Probe. Since attributive adjectives in German do not display person agreement in German, person features are irrelevant for the present discussion. They will therefore be ignored in what follows.

Agree between v and the higher D-copy has multiple results. First of all, v is associated with the gender feature of D.⁴³ This gender feature is specified as neuter and was already shared between the higher D, the lower D and N. Agree between v and D therefore has the result that the gender feature that entered the derivation on N, is shared between N, the two D-copies, and v . Secondly, v is associated with the number feature of D. This feature is underspecified, i.e. it consists of the number attribute without a value. It is already shared between the two D-copies, A, and N because of the earlier instances of Agree. Thirdly, v shares its case feature, which is specified as accusative, with D. Since the case feature of D was already shared between N, the two D-copies and A, sharing between D and little v also entails that N and A are associated with v 's case feature.

In this way, the adjective in (58) leaves narrow syntax with a case feature that is specified as accusative, an underspecified number feature and an underspecified gender feature. The case feature and the number feature are both shared with other syntactic nodes. The gender feature on A does not participate in any Agree relation. It is therefore not shared with any other node. This feature specification of A at the outcome of narrow syntax is given in (66).

(66) OUTCOME NARROW SYNTAX
A: [#_i: , Gen: , Case: acc]

Subsequently, A is submitted to the SM-interface. Number and case on A are shared with N. These features (or some aspects of these features) are interpretable at the CI-interface on N. In line with the CI-dependent SM-interpretation condition that I proposed in chapter 4, these features pass through the SM-interface and enter into the morphological component of the grammar. This is not the case for the underspecified gender feature on A. This feature is not shared with N on which gender is interpretable. Given that it is not interpretable on any of the positions it is associated with, the underspecified gender feature is deleted at the SM-interface and does not enter into the morphological component. This SM-interpretation of the features A is associated with is shown in (67).

(67) SM-INTERPRETATION
A: [#_i: , Gen: , Case: acc] → A: [#: , Case: acc]

The adjective thus reaches Vocabulary Insertion with an underspecified number feature and a case feature that is specified as accusative. At Vocabulary Insertion, the adjectival root *kalt* is inserted and VI-rule A (see (54a) above) applies, spelling out the features of A as the *-e* ending.

(68) VOCABULARY INSERTION
A- [#: , Case: acc] → *kalt-e*

⁴³ Although D is deactivated as a gender Probe, its gender feature can participate in new Agree relation if it is targeted as Goal by a higher gender Probe (see chapter 4). This is what happens in the case in hand, in which D is targeted as Goal by v .

This concludes the discussion of the derivation of the DP in (58).

5.4.2. Plural masculine genitive DP

I will now consider in detail the derivation of the plural masculine genitive DP in (69).

- (69) *der alt-en Wein-e* WEAK, GEN, MASC, PL
 the.GEN.PL old-WEAK wine-PL
 ‘the old wines’

This derivation will illustrate two different aspects of my account for weak adjectival inflection in German. First, it illustrates my claim that no number feature is licensed in German on adjectives in plural definite DPs (see section 5.2 of this chapter). Second, it illustrates the absence of a case feature on adjectives in definite DPs with inherent case (see section 5.1.2 of this chapter).

The first step in the derivation of (69) is the merger of D and N, as in (70). In accordance with the view on the syntactic representation of gender and number proposed in section 3, N enters this derivation with a number feature that is specified as plural and a gender feature that is specified as masculine. In line with the view that inherent case is specified on N when N enters narrow syntax (see section 5.1.2 of this chapter for discussion), N is also equipped with a case feature that is specified as genitive. D on the other hand has underspecified gender, number and case features, by virtue of being a Probe for these features.

- (70) STEP #1: MERGE (D,N)

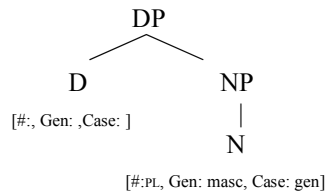

The next step is Agree between D and N. This results in the sharing of the gender, number and case features of N between D and N, as in (71).

- (71) STEP #2 AGREE (D, N)

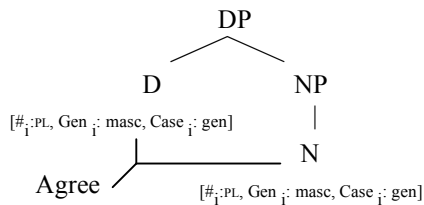

Agree in (71) associates D with the fully specified gender, number, and case features of N. For this reason, D is completely deactivated as a gender, number and case Probe. This has the effect that D will not enter into any other Agree relations than the one in (71). This is different from the derivation of the neuter accusative singular definite DP in section 5.4.1. In that derivation, D remained an active case and number Probe, which permitted D to enter into Agree relations for these features with A.

The next step in the derivation is to adjoin the adjective to DP, as in (72).

(72) STEP #3: MERGE (AP, DP)

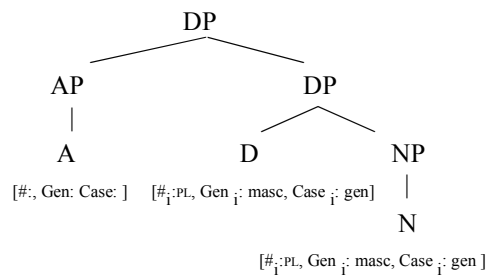

Remember that the adjective has underspecified gender, number, and case features by virtue of being a Probe for these features. However, it does not trigger Agree, given that it does not dominate any element that has these features. Note that D also does not enter into Agree with A, despite the fact that AP is dominated by a DP node. The application of Agree in (71) already deactivated all probing features in the label of D. Hence, the DP node dominating AP is not a Probe. The derivation therefore continues without the adjective participating in any Agree relation.

The next step in the derivation is internal merge of D. This step is shown in (73).

(73) STEP #5: INTERNAL MERGE D

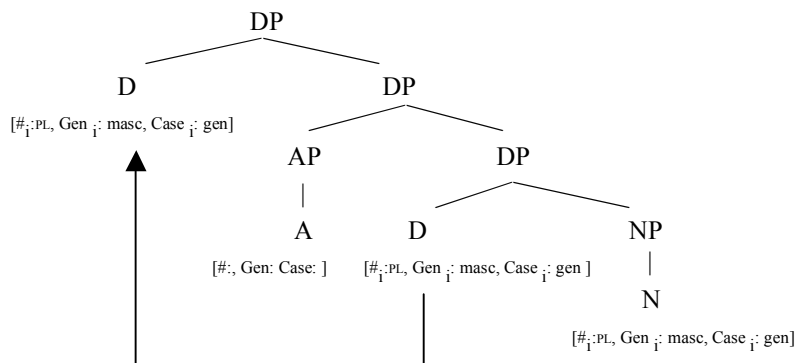

The higher D-copy that is created in this step is an exact copy of the lower D. It therefore shares gender, number, and case features with N. Since these features are

all fully specified, the higher D-copy is not a Probe, just like in Swedish definite DPs (see chapter 4). It will therefore not enter into an Agree relation with A. In addition, it will prevent any DP-external Probe from establishing an Agree relation with A for gender, number, and case, because the higher D-copy always constitutes a closer Goal for such a Probe than A. The adjective in (69) therefore does not participate in any Agree relation. It will thus leave narrow syntax with underspecified and unshared number, gender, and case features, as in (74a). In chapter 4, I proposed that only features that are associated to an element on which they are CI-interpretable are interpretable at the SM-interface. The features with which the adjective leaves narrow syntax are uninterpretable on A at the CI-interface. In addition, they are not shared with any other element. The underspecified gender, number, and case feature of A are therefore not interpreted at the SM-interface. As a result, the adjective enters the morphological component without any gender, number, and case features, as in (74b).

- (74) a. OUTPUT NARROW SYNTAX
A: [#: , Gen: , Case:]
b. SM-INTERPRETATION
A: [#: , Gen: , Case:] → A: [∅]

At Vocabulary Insertion, the lack of gender, number and case features on A is spelled out by VI-rule B as the *-en* suffix as in (75).

- (75) VOCABULARY INSERTION
A-[∅] → *alt-en*

During the derivation of the masculine, genitive, plural DP in (69), narrow syntax does not license any case, gender, and number features on the adjective. Morphology spells out this lack of licensing as the default *-en* suffix.

5.5. A note on masculine singular accusative

In the previous sections, I introduced and illustrated my account of weak adjectival inflection in German. However, I carefully excluded until now adjectives in definite masculine accusative singular DPs from the discussion. Adjectives in these DPs take *-en* as their ending. This is illustrated in (76).

- (76) *den* *alt-en* *Wein* MASC, SG, ACC
the.MASC.ACC old-EN wine
'the old wine'

Within the weak paradigm, the masculine accusative singular occupies an exceptional place for a couple of reasons. First, it is the only cell in the weak paradigm in which accusative is marked differently from nominative. As one can see

in the table in (77), there is no distinction between nominative and accusative in other parts of the weak paradigm.

(77) WEAK ADJECTIVAL INFLECTION IN GERMAN

	Singular			Plural
	Masculine	Neuter	Feminine	
Nominative	-e	-e	-e	-en
Accusative	-en	-e	-e	-en
Dative	-en	-en	-en	-en
Genitive	-en	-en	-en	-en

Second, masculine accusative singular is the only case in the weak paradigm in which masculine gender receives a different ending than neuter and feminine gender (see again the table in (77)). The ending for the singular masculine accusative is thus exceptional in that it marks a case distinction and a gender distinction that are not marked elsewhere in the paradigm. In addition to this, the form of the masculine accusative singular ending, *-en*, is also surprising. This ending is homophonous to the weak adjectival ending that occurs in the inherent cases with all genders and in the plural with all cases and all genders (see the table in (77)). Above, I argued that this *-en* ending is the elsewhere form, i.e. the adjectival ending that does not mark any gender, number and case distinctions (see section 5.3). It is surprising that the masculine singular accusative ending that marks distinctions not marked anywhere else in the paradigm takes the same form as the elsewhere ending that does not realize any distinctions.

The masculine singular accusative is not only special within the weak paradigm. It also has a special status in both the strong adjectival inflection and in the inflectional paradigm of the definite article. In these paradigms, as in weak adjectival inflection, the masculine accusative singular is the only form that seems to mark accusative case. Only in the masculine singular, there are different forms for nominative and accusative. In all other cases the accusative form is identical to the nominative form. This is shown in the table in (78) for the strong adjectival inflection and in the table in (79) for the definite article.

(78) STRONG ADJECTIVAL INFLECTION IN GERMAN (STRUCTURAL CASE ONLY)

	Singular			Plural
	Masculine	Neuter	Feminine	
Nominative	-er	-es	-e	-e
Accusative	-en	-es	-e	-e

- (79) INFLECTION OF THE GERMAN DEFINITE ARTICLE (STRUCTURAL CASE ONLY)

	Singular			Plural
	Masculine	Neuter	Feminine	
Nominative	der	das	die	die
Accusative	den	das	die	die

There thus seems to be something special about masculine singular accusative in general, not only in the weak adjectival inflection.

This special status of singular accusative masculine is reflected in my analysis in the sense that my analysis does not predict the *-en* ending in the singular accusative masculine. Instead, my analysis predicts that adjectives in masculine accusative singular DPs take the *-e* ending. In order to show this, I will now take a closer look at what the derivation of masculine singular accusative definite DPs would look like under my analysis.

In section 3 of this chapter, I claimed that singular is syntactically represented by an underspecified number feature and masculine by a gender feature that is specified as masculine. In addition, I claimed in section 5.1.2 of this chapter that N in DPs with structural case starts off the derivation with an underspecified case feature. Hence, N in masculine singular accusative DPs, like the one in (76), enters narrow syntax with the feature specification in (80).

- (80) N: [#: , Gen: masc, Case:]

Under my analysis of weak adjectival inflection, adjectives only share case, number and gender features with N, in case these features are underspecified on N at the beginning of narrow syntax. Given the feature specification of N at the beginning of narrow syntax in (80), adjectives in definite singular masculine accusative DPs thus share case and number features with N, but not a gender feature. Although it is initially underspecified, the case feature that N and A share is specified as accusative at the end of narrow syntax as the result of Agree with *v* (see section 5.1.2 above). Adjectives in singular masculine accusative definite DPs hence leave narrow syntax with the feature specification in (81a). Given my condition for interpretation at the SM-interface (see chapter 4), the shared number and case features enter into the morphological component, while the unshared gender feature does not. This is shown in (81b).

- (81) a. OUTPUT NARROW SYNTAX
A: [#_i: , Case_i: acc, Gen:]
b. SM-INTERFACE INTERPRETATION
A: [#_i: , Case_i: acc, Gen:] → A: [#: , Case: acc]

Adjectives in singular masculine accusative definite DPs reach Vocabulary Insertion with an underspecified number feature and a case feature that is specified as accusative.

In section 5.3, I proposed two VI-rules for the weak adjectival inflection. These rules were introduced in (54) above. They are repeated here in (82).

- (82) VOCABULARY INSERTION RULES GERMAN WEAK ADJECTIVAL
INFLECTION:
- a. Rule A: A-[#: , Case: nom/acc] → A-*e*
 - b. Rule B: A-[∅] → A-*en* (elsewhere rule)

As argued above, adjectives in definite masculine singular accusative DPs carry under my analysis [#: , Case: acc] as their feature specification at Vocabulary Insertion. Therefore, the structural descriptions of both VI-rule A and B are satisfied. The subset principle (Halle 1997) dictates in that case that the more specific VI-rule, i.e. the rule whose structural description is more restrictive, applies. In this case, the more specific rule is VI-rule A. Application of this rule spells out the adjectival inflection as the *-e* ending as in (83).

- (83) VOCABULARY INSERTION
A-[#: , Case: acc] → A-*e* (VI-rule A)

Hence, my analysis predicts that the inflection on adjectives in masculine, accusative, singular definite DPs is *-e*. However, this is contrary to fact. As shown above in (76), the actual ending is *-en* in these DPs.⁴⁴ My analysis of weak adjectival inflection thus faces a problem with respect to the adjectival inflection in definite masculine singular accusative DPs.⁴⁵

Note that it is impossible to solve this problem through means of an additional VI-rule that spells out the adjectival inflection as *-en* in definite masculine accusative singular DPs. As explained above, adjectives do not enter into an Agree relation with respect to gender in masculine definite DPs. As a consequence, they are unspecified for gender at Vocabulary Insertion. However, the same holds for adjectives in definite neuter DPs (see section 5.1.1 above). Therefore, the feature specification for adjectives in singular definite accusative masculine DPs are identical at Vocabulary Insertion to that of adjectives in singular definite neuter DPs. Hence, it is impossible to write a VI-rule that applies to adjectives in definite singular accusative masculine DPs, but not to adjectives in singular accusative neuter DPs.

⁴⁴ In (82), the *-en* ending is the result of applying the elsewhere VI-rule B. Under my analysis, applying VI-rule B instead of VI-rule A is impossible, because it would violate the subset principle.

⁴⁵ In my analysis of weak adjectival inflection, the definite D mediates between the adjective and the noun. As one can see in the table in (79), the definite article also takes the elsewhere *-en* ending (cf. *d-en*) as its inflection in masculine singular accusative DPs. If this ending on the definite article signals a lack of gender, number, and case features on the definite D in singular, masculine, accusative DPs, D would be unable to license any features on A. In that case, the presence of the default *-en* ending on the adjective would be unsurprising. However, I will not pursue this idea any further, since I do not have any indication that definite Ds really lack gender, number and case features in masculine, accusative singular DPs. A proposal along these lines would therefore only shift the problem from the adjective to the definite article, instead of being a real solution.

Yves d'Hulst (personal communication) notices that it might be relevant to this point that in Latin the default case was accusative.

As mentioned above, the masculine accusative singular is identical to the default *-en* ending. As shown above, adjectives with weak inflection in masculine, accusative singular enter the morphological component with a [case:acc]-feature, which should in principle block the insertion of the default *-en* ending. In order to formalize the intuition that the default *-en* ending is showing up on the adjective in the masculine, accusative, neuter, I stipulate the impoverishment rule (cf. Halle 1997) in (84).⁴⁶

(84) A-[case: acc] → A-[∅]/_ D-[gen: masc]

This rule will delete [case:acc] in case D has a [gen:masc] feature making it possible for VI-rule B in (82) to apply afterwards, realizing the adjectival inflection as the default *-en* ending. I leave it to further research to find a more principled account for the masculine singular accusative in the German weak adjectival inflection.

5.6. German weak adjectival inflection: summary

In this section, I showed that my analysis accounts for German weak adjectival inflection largely in the same way as it does for Swedish. The only difference between Swedish and German is that in German some features are underspecified on N at the start of the syntactic derivation, like singular number, feminine gender, and structural case. Since they do not deactivate D as a Probe, adjectives in German definite DPs share these underspecified features with N and D as the result of Agree. However, those features that are fully specified on N at the beginning of the syntactic derivation are not shared between A and N. These features deactivate D as a Probe. This deactivation prevents D from entering into Agree with A. Since some sharing is possible, adjectives in German definite DPs can enter the morphological component with some gender, number, and/or case specifications. The exact feature specifications with which adjectives enter the morphological component in German definite DPs were given in the table in (53) above, repeated here in (85).

⁴⁶ Thanks to David Pesetsky for suggesting this impoverishment rule.

- (85) FEATURE SPECIFICATION ON ADJECTIVES IN DEFINITE DP AFTER SUBMISSION TO THE SM-INTERFACE

	Singular			Plural		
	Masc	Neut	Fem	Masc	Neut	Fem
Nom	[Case: nom], [#:]		[Gen:], [Case: nom], [#:]	[Case: nom]		[Gen:], [Case: nom]
Acc	⁴⁷	[case: acc] [#:]	[Gen:], [Case: acc], [#:]	[Case: acc]		[Gen:], [Case: acc]
Dat	[#:]		[Gen:], [#:]	[∅]		[Gen:]
Gen						

These feature specifications are then mapped onto two different adjectival endings, i.e. the *-e* and *-en* endings, by the two VI-rules proposed in (54) above. These rules are repeated here in (86).

- (86) VOCABULARY INSERTION RULES GERMAN WEAK ADJECTIVAL INFLECTION:
- Rule A: A-[#: , Case: nom/acc] → A-*e*
 - Rule B: A-[∅] → A-*en* (elsewhere rule)

The application of these two VI-rules to the feature specifications in (85) yield the weak adjectival paradigm, as in (87).

- (87) MORPHOLOGICAL REALIZATION OF THE GENDER, NUMBER AND CASE SPECIFICATION OF ADJECTIVES IN DEFINITE DPS.

	Singular			Plural		
	Masc	Neut	Fem	Masc	Neut	Fem
Nom		<i>-e</i>				
Acc		(VI-rule A)				
Dat				<i>-en</i>		
Gen				(VI-rule B)		

In this way, underspecification of features on N at the beginning of narrow syntax eventually leads to the morphological marking of some gender, number, and case distinctions on the German weak adjectival inflection.

⁴⁷ Since I excluded the singular masculine accusative weak ending from most of the discussion, I do not specify its feature specification in the table in (85). I refer the reader to section 5.5 for further discussion.

6. The mixed paradigm

In the previous sections, I introduced my account for strong and weak adjectival inflection in German. In addition to these two inflectional paradigms, German has a third paradigm of adjectival inflection: the so-called mixed paradigm (see among others Sternefeld (2004) and Roehrs (2006)). As pointed out in section 2 of this chapter, adjectives in DPs that are introduced by the indefinite article *ein*, by possessive pronouns like *mein* ‘my’ or by the negative quantifier *kein* ‘no’ inflect according to this paradigm. It is called the mixed paradigm, because it partly consists of endings from the weak paradigm and partly of endings from the strong paradigm. The strong endings occur in case the DP is masculine nominative singular or neuter nominative/accusative. In all other cases, the endings are taken from the weak paradigm. This is shown in the table in (88), in which the striped cells indicate the strong endings.

(88) GERMAN ADJECTIVAL INFLECTION: MIXED PARADIGM

	Singular			Plural
	Masculine	Neuter	Feminine	
Nominative	<i>-er</i>	<i>-es</i>	-e	-en
Accusative	-en	<i>-es</i>	-e	-en
Dative	-en	-en	-en	-en ⁴⁸
Genitive	-en ⁴⁹	-en	-en	-en

 = strong ending

 = weak ending

The occurrence of both weak and strong endings in the mixed paradigm is illustrated in (89). In (89a), the adjective is contained in a neuter singular nominative DP that is introduced by the indefinite article. The ending on the adjective is in that case a strong ending. In (89b), the adjective occurs in a neuter singular dative DP. In that case, the adjectival ending is weak.

- (89) a. *ein alt-es* *Haus* STRONG, NOM, NEUT, SG
 a old-NEUTER.SG.NOM/ACC.STRONG house
 ‘an old house’
- b. *ein-em* *alt-en* *Haus* WEAK, DAT, NEUT, SG
 a-DATIVE.SG.NEUTER old-WEAK house
 ‘an old house’

Sauerland (1996), Müller (2004) and Roehrs (2006) among others make a striking observation about the distribution of the strong and weak adjectival endings in the

⁴⁸ In the plural dative, the noun takes an additional -n ending.

⁴⁹ In the masculine and neuter genitive singular the noun takes an additional -s ending.

mixed paradigm. The strong endings occur in those cases in which the determiner does not carry an inflectional ending (cf. (89a)), while the weak endings occur in case the determiner is inflected (cf (89b)). The inflection of the indefinite article is shown for the indefinite article in the table in (90).⁵⁰ The indefinite article is uninflected in the neuter singular nominative/accusative and in the masculine nominative singular. This corresponds exactly to the cases in which the adjective receives a strong ending. In all other cases the indefinite article is inflected and, as one can see in the table in (88), adjectives take a weak ending. The facts are the same for the other determiners that trigger mixed adjectival inflection on the adjectives, e.g. *mein* ‘my’ and *kein* ‘no’.⁵¹

(90) INFLECTION OF THE INDEFINITE ARTICLE

	Singular		
	Masculine	Neuter	Feminine
Nominative	Ein	Ein	Ein-e
Accusative	Ein-en	Ein	Ein-e
Dative	Ein-em	Ein-em	Ein-er
Genitive	Ein-es ⁵²	Ein-es	Ein-er

 = uninflected

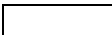
 = inflected

The distribution of strong and weak endings in the mixed paradigm thus clearly depends on whether the determiner carries inflection or not. Before I can show how my analysis of the strong-weak distinction accounts for the mixed paradigm, I first need to examine in some more detail the German indefinite article.

In chapter 4, I argued that the Swedish indefinite article is not an instance of D, but is instead syntactically represented as a numeral. In Swedish, adjectives in DPs introduced by the indefinite article take strong inflection. Under my analysis, weak adjectival inflection arises in case D is a Probe that is completely or partially deactivated before the adjective is merged. In all other cases, strong adjectival inflection is licensed as a result of Indirect Agree. Given the agreement it displays, the Swedish indefinite article is a Probe. If it were an instance of D, one would therefore expect the Swedish indefinite article to co-occur with weak adjectival inflection, contrary to fact. Analyzing the Swedish indefinite article as a numeral instead of D therefore offers an explanation for the presence of strong inflection on adjectives in DPs introduced by the indefinite article.

Contrary to its Swedish counterpart, the German indefinite article triggers weak adjectival inflection in a part of the mixed paradigm, see the table in (88)

⁵⁰ Note that there is no plural indefinite article in German, see also footnote 16 above.

⁵¹ There is however one difference between these determiners and the indefinite article. Possessive pronouns and the negative quantifier *kein* ‘no’ have plural forms, unlike the indefinite article. These plural forms are all inflected. As expected, the ending on the adjective is weak in these cases.

⁵² In the genitive singular masculine and neuter, the noun receives a –s ending.

above. Since weak adjectival inflection is only licensed because of a probing D, the co-occurrence of the German indefinite article and adjectives with weak inflection indicates that the indefinite article is an instance of D in German, contrary to its Swedish counterpart.⁵³ As mentioned above, possessive pronouns like *mein* ‘my’ and negative quantifiers like *kein*, ‘no’ also trigger the mixed paradigm. Hence, they can also co-occur with adjectives carrying weak inflection. I conclude that they are therefore also instances of D. Put differently, I propose to analyze all determiners that trigger mixed adjectival inflection as instances of D.

As I showed above, there is a correlation in the mixed paradigm between agreement on the determiner and the kind of ending the adjective receives. If the determiner displays agreement with the noun, the adjective takes a weak ending. If, on the other hand, the determiner does not display agreement the adjective takes a strong ending. The latter case applies in the nominative masculine singular and in the nominative/accusative neuter singular (see above), the former case in all other cases. On the hypothesis that the determiners that trigger the mixed paradigm are instances of D, this correlation receives a straightforward explanation.

First, consider those cases in which the determiners that trigger the mixed paradigm display agreement with the noun. On this hypothesis that they are instances of D, D must thus be a Probe in case the determiners that trigger the mixed paradigm display agreement with N. From that perspective, it is unsurprising that the weak adjectival inflection shows up if the determiner displays agreement. In chapter 4 and in section 5 of this chapter, I argued that the weak adjectival inflection is the result of D being a Probe. Because of its probehood, D enters into Agree with N. It therefore gets (partially) deactivated as a Probe. Subsequent internal merge of D then puts D in a position in which it acts as an intervener for Agree between a DP-external Probe and A. This results in the weak adjectival inflection. Given that D is also a Probe in case the determiners that trigger the mixed paradigm display agreement, the occurrence of the weak adjectival inflection in the mixed paradigm can be explained in the same way. Thus like in definite DPs, D enters into Agree with N in case determiners that trigger the mixed paradigm display agreement. Internal merge then puts these Ds in a position in which they shield A from any probing from DP-external Probes. This results in weak adjectival inflection.

In those cases in which the determiners do not display agreement with N, there is however no evidence that D is a Probe. I will therefore assume that it is not. This renders the situation similar to DPs without articles in which strong adjectival inflection is licensed (see chapter 4 and section 4 of this chapter). D does not have any case, gender and number features when it is internally merged. It can therefore not act as an intervener for Agree between A and DP-external Probe. As a result, a

⁵³ Other determiners might also differ crosslinguistically in their syntactic status. For instance, the German universal quantifier *jeder* ‘every’ triggers weak adjectival inflection, as in (i), while its Dutch counterpart *ieder* ‘every’ triggers strong adjectival inflection, as in (ii).

- | | | | |
|-----|-------------------------|------|-----------------------|
| (i) | <i>jedes alt-e Haus</i> | (ii) | <i>elk oud-∅ huis</i> |
| | every old-WEAK house | | every old-strong huis |
| | ‘every old house’ | | ‘every old house’ |

As for the indefinite article, this shows that German *jeder* ‘every’ is an instance of D and Dutch *elk* is not.

DP external Probe, i.e. a case assignor, will first enter into an Agree relation with A and then with N. This results in indirect Agree between A and N and hence the licensing of strong adjectival inflection.

In this way, the distribution of weak and strong endings in the mixed paradigm is directly linked to the agreement properties of the determiner. In case the determiner displays agreement, D is a Probe. This results in the licensing of weak adjectival inflection in a way similar to that in definite DPs. In case the determiner does not display agreement, D is not a Probe. This results in the licensing of the strong adjectival inflection in a similar manner as in DPs without articles.

Note that this presupposes a rather awkward distribution of probing features for those determiners that trigger the mixed paradigm. If N is masculine, nominative singular or neuter, nominative/accusative singular, these determiners do not have probing features. However, they do have probing features in case N is endowed with other features. This particular distribution of probing features is an interesting issue. However, the goal of this section is not to explain the agreement properties of the determiners that trigger the mixed paradigm. Instead, the goal of this section is to show that my analysis straightforwardly accounts for the connection of the agreement properties of D and the type of inflection on the adjective. I will therefore leave an account for the distribution of the probing features on determiners that trigger the mixed paradigm to further research.

7. Conclusion

In this chapter, I showed that the analysis of strong and weak adjectival inflection that I proposed in chapter 4 also accounts for the inflection of attributive adjectives in German. However, there were some small differences between German and Swedish, the language used in Chapter 4 to illustrate my analysis.

The first difference concerns case. German determiners and adjectives display case agreement with N, while their Swedish counterparts do not. As a consequence, adjectives in German are case Probes, in addition of being number and gender Probes.

The second difference concerns the specification of features on N. The gender and number features that participate in adjectival agreement in Swedish are fully specified on N. The features that participate in adjectival agreement in German do not necessarily need to be. They can also be underspecified. This difference explains why the German weak adjectival inflection expresses some case, gender, and number distinctions, while weak adjectival inflection in Swedish does not.

The final difference between German and Swedish is the status as the indefinite article. In Swedish, the indefinite article is syntactically represented as a numeral, while in German it is an instance of D. This explained why adjectives in Swedish DPs that are introduced by the indefinite article always carry strong adjectival inflection, while in German it can either carry a strong or a weak ending, depending on whether the article displays agreement or not.

In the next chapter, I will return to the discussion of the structural condition on Agree that I initiated in chapter 3. I will show that my analysis of strong and weak adjectival inflection introduced in this and the previous chapter can shed some new light on that matter.

Chapter 6

Romance adjectival agreement

The dominance requirement revisited

1. Introduction

Chapter 3 was devoted to determining the exact definition of the structural condition on Agree. In that chapter, I considered three different formulations of this condition: the complement requirement (Chomsky 2001: 135), the c-command requirement (Chomsky 2001: 122) and the dominance requirement. Of these three requirements, I discarded the complement requirement, ‘the Goal must be in the complement of the Probe’, because it does not allow for Agree between a Probe and a Goal in the specifier of the Probe. As shown by Rezac (2003, 2004), such an Agree relation must be allowed in order to account for person agreement on finite verbs in Georgian.

It was however more difficult to decide between the two remaining competing formulations of the structural condition on Agree, the c-command requirement and the dominance requirement. The definitions of these two requirements are repeated in (1).

- (1) a. C-COMMAND REQUIREMENT
The Probe must c-command the Goal. (cf. Chomsky 2001: 122)
- b. DOMINANCE REQUIREMENT
The Probe must dominate the Goal.

Each of these two requirements faces empirical problems, albeit to a lesser extent than the complement requirement. Because of these problems, it was impossible to decide between the two requirements on an empirical basis. However, I argued towards the end of chapter 3 that it is feasible to decide between them on theoretical grounds. The dominance requirement is theoretically simpler than the c-command requirement, since dominance is a more primitive syntactic relation than c-command. Because of its simplicity, I claimed that the dominance requirement should be preferred over the c-command requirement. I therefore adopted the dominance requirement as the structural condition on Agree.

The theoretical simplicity of the dominance requirement does of course not resolve its empirical problems. In this chapter, I therefore reexamine the empirical problems that I pointed out for the dominance requirement in chapter 3. I will show that these problems are only apparent in the light of two independently needed

analyses. The first of these analyses is my account of strong and weak adjectival inflection (see chapters 4 and 5), the second one is an account for the absence of weak adjectival inflection in Romance that I will propose below. As a result, the dominance requirement will not only be the theoretically simplest formulation of the structural condition on Agree, but also the one that is empirically the most adequate.

In chapter 3, I introduced two different empirical problems for the dominance requirement. The first problem concerns Swedish. In Swedish, attributive adjectives in indefinite DPs display agreement, just like predicative adjectives, but unlike their counterparts in definite DPs (see also chapter 4). This is unexpected if the dominance requirement is the structural condition on Agree. The second problem has to do with adjectival agreement in the Romance languages. In all Romance languages, agreement on predicative and attributive adjectives is identical, while the dominance requirement predicts that they should not be. Below, I will first show that the Swedish pattern straightforwardly follows from my Indirect Agree analysis of strong adjectival inflection in a way that it is compatible with the dominance requirement. I will then argue that the Romance pattern also follows under the dominance requirement as long as an independently motivated difference in DP-structure between Romance and German is taken into account.

2. The Swedish attributive-predicative agreement symmetry

As stated above, the first problem that I pointed out in chapter 3 for the dominance requirement concerns adjectival agreement in Swedish. However, under my Indirect Agree analysis of strong adjectival inflection, adjectival agreement in Swedish no longer poses a problem for the dominance requirement. In order to show this, I will first briefly review the reason why adjectival agreement in Swedish appears to be problematic for the dominance requirement.

In Swedish, attributive adjectives in indefinite DPs receive strong adjectival inflection (see chapters 3 and 4). This strong adjectival inflection expresses agreement in gender and number between the adjective and the noun modified by the adjective. This is illustrated in (2).

- | | | | | | |
|-----|----|--------------------------------------------|--------------------------------|-----------------------|-----------------------|
| (2) | a. | <i>en</i>
a.NONNEUTER
'a young girl' | <i>ung</i>
young | <i>flicka</i>
girl | NON-NEUTER, SG, INDEF |
| | b. | <i>ett</i>
the.NEUTER
'a big house' | <i>stor-t</i>
big-NEUTER.SG | <i>hus</i>
house | NEUTER, SG, INDEF |
| | c. | <i>stor-a</i>
big-PL
'big houses' | <i>hus</i>
house | | NEUTER, PL, INDEF |
| | d. | <i>ung-a</i>
young-PL
'young girls' | <i>flick-or</i>
girl-PL | | NON-NEUTER, PL |

Swedish predicative adjectives take endings that are identical to those of the strong adjectival inflection. In the case of predicative adjectives, these endings express gender and number agreement with the subject of the adjective. This is illustrated by the copular sentences in (3).

- (3) a. *flicka-n* *är* *ung.* NON-NEUTER SG, DEF.
 Girl-DEF.NONNEUTER is young
 ‘the girl is young’
- b. *hus-et* *är* *stor-t* NEUTER, SG, DEF
 house-DEF.NEUTER is big-NEUTER
 ‘the house is big’
- c. *flick-or-na* *är* *ung-a.* NON-NEUTER, PL, DEF
 girl-PL-DEF.NON-NEUTER is young-PL
 ‘the girls are young’
- d. *hus-en* *är* *stor-a* NEUTER, PL, DEF
 house-DEF.PL.NEUTER are big-PL
 ‘the houses are big’

As pointed out in chapter 3, the fact that both attributive adjectives in indefinite DPs and predicative adjectives display agreement is unexpected under the dominance requirement. The dominance requirement only predicts Agree to be possible with predicative adjectives, not with attributive adjectives. I will now briefly recapitulate why this is expected.

Let’s first consider predicative adjectives. In chapter 3, I adopted the fairly standard assumption that the subject of predicative adjectives enters the syntactic derivation as the specifier of AP. The subject is therefore dominated by an AP-node, i.e. a node that belongs to the projection of A. On BPS-view of labeling, this node gets its label from A. Given that A contains probing features, this AP-node is a Probe. Since this AP-node dominates the subject, the dominance requirement is met. Agree is thus predicted to take place, like in (4).

- (4) SUBJECT-PREDICATE
 AGREEMENT: OK

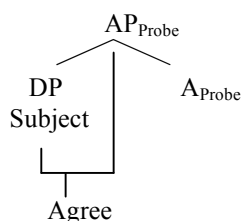

Given that predicative adjectives in Swedish display agreement (as shown in (3) above), this prediction of the dominance requirement is borne out.¹

The dominance requirement however does not seem to make the correct prediction with respect to attributive adjectives in Swedish indefinite DPs. In this thesis, I followed Svenonius (1994) (among others) in that attributive adjectives are adjuncts. In chapter 2, I proposed that attributive adjectives in Swedish are adjoined to DP. On these assumptions, the label of A is not shared with any node that dominates N. In other words, no node of the projection of A dominates N. The probing features contained in the label of A hence do not dominate N. The dominance requirement therefore predicts that Agree cannot be established between an adjoined A and N, as in (5).

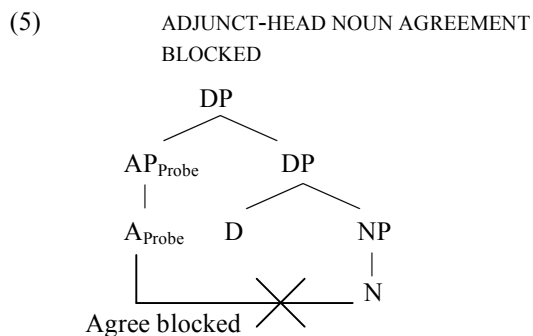

However, this prediction of the dominance requirement does not seem to be borne out. As shown in (2) above, Swedish attributive adjectives in indefinite DPs display agreement with the noun they modify.

The agreement between attributive adjectives in Swedish indefinite DPs thus seems to pose a problem for the dominance requirement. However, I resolved this problem in chapter 4 by proposing that the agreement in Swedish indefinite DPs and the noun is not the result of a direct Agree relation between A and N. Instead, I argued that this agreement is the result of Indirect Agree. Indirect Agree is licensed by the case assigner of the indefinite DP, e.g. T or v. In (6), I indicated the case assigner as X. The case assigner first enters into Agree with A, *Agree 1* in (6) and then with N, *Agree 2* in (6). Note that both these instances of Agree comply with the dominance requirement. The label of the case assigner is shared on the label-sharing view of projection between the case assigning head and its projection XP in (6). The latter node both dominates A and N. Hence, the probing features in the label of the case assigner dominate both A and N.

¹ This prediction of the dominance requirement is however not borne out in German, Dutch and Yiddish. In these languages, predicative adjectives do not display agreement with their subject (Vikner (2006)). I will have to leave this issue to further research.

(6) AGREE RELATIONS IN SWEDISH INDEFINITE DPs

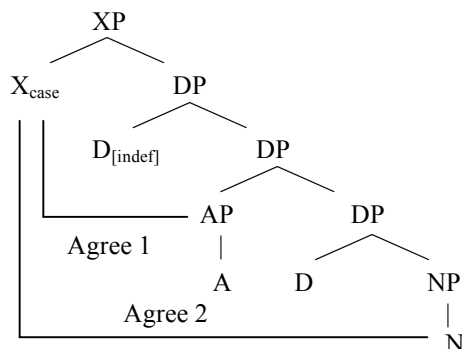

The two instances of Agree in (6) result in A and N sharing features. As a consequence of this, the adjective displays agreement with the noun it modifies without a direct Agree relation between A and N. Since both instances of Agree in (6) observe the dominance requirement and no direct Agree relation is established between A and N, the agreement between attributive adjectives and the head noun in Swedish indefinite DPs is accounted for without violating the dominance requirement.

Given my analysis of Swedish adjectival agreement, the agreement in Swedish indefinite DPs between attributive adjectives and the noun they modify thus ceases to be a problem for the dominance requirement. The fact that both predicative adjectives and their attributive counterparts in indefinite DPs display agreement in Swedish is therefore no longer an argument against the dominance requirement.

3. Adjectival agreement in Romance and beyond

3.1. The Romance predicative-attributive agreement symmetry

In the previous section, I was able to discard the first of the two problems for the dominance requirement. The second problem that I pointed out in chapter 3 concerns adjectival agreement in Romance. In the Romance languages, both attributive and predicative adjectives display agreement. The attributive adjectives agree with their head noun, while the predicative adjectives agree with their subject. This is illustrated in (7) and (8) for Spanish. In the DPs in (7), the attributive adjectives agree in gender and number with the noun they modify. In the copular sentences in (8), the predicative adjectives agree in gender and number with their subject.

- (7) a. *el niño alt-o* MASC, SG, DEF [Spanish]
 the.MASC boy tall-MASC
 ‘the tall boy’
- b. *la niña alt-a* FEM, SG, DEF
 the.FEM girl tall-FEM
 ‘The tall girl’
- c. *los niños alt-o-s* MASC, PL, DEF
 the.MASC.PL boys tall-MASC-PL
 ‘the tall boys’
- d. *las niñas alt-a-s* FEM, PL, DEF
 the.FEM.PL girls tall-FEM-PL
 ‘the tall girls’
- (8) a. *el niño es alt-o* MASC, SG [Spanish]
 the.MASC boy is tall-MASC
 ‘The boy is tall’
- b. *la niña es alt-a* FEM, SG
 the.FEM girl is tall-FEM
 ‘The girl is tall’
- c. *Los niños son alt-o-s* MASC, PL
 the.MASC.PL boys are tall-MASC-PL
 ‘The boys are tall’
- d. *Las niñas son alt-a-s* FEM, PL
 the.FEM.PL girls are tall-FEM-PL
 ‘The girls are tall.’

In chapter 3, I argued that the dominance requirement does not allow for Agree to be established between attributive adjectives and the nouns they modify, but that it does allow for Agree between predicative adjectives and their subject (see also section 2 of this chapter). Hence, the fact that attributive adjectives display agreement in Romance just like their predicative counterparts seem to pose a problem for the dominance requirement.

The agreement on attributive adjectives in Romance is reminiscent of the agreement displayed by attributive adjectives in Swedish indefinite DPs. In the previous section, I argued however that agreement in Swedish is not problematic for the dominance requirement. My analysis of strong and weak adjectival inflection provides an account of this agreement that is compatible with dominance requirement. Unfortunately, this analysis cannot also account for agreement on attributive adjectives in Romance. The reason for this is simple. Romance does not have a strong-weak distinction with respect to adjectival agreement. In Romance, attributive adjectives inflect independently of the definiteness or other properties of the DP they occur in. This is illustrated in (9) for Spanish. The adjectives in the indefinite DPs (9) carry the same inflection as their counterparts in the definite DPs in (7) above.

- (9) a. *un niño alt-o* MASC, SG, INDEF [Spanish]
 a.MASC boy tall-MASC
 ‘a tall boy’
- b. *una niña alt-a* FEM, SG, INDEF
 a.FEM girl tall-FEM
 ‘a tall girl’
- c. *unos niños alt-o-s* MASC, PL, INDEF
 a.MASC.PL boys tall-MASC-PL
 ‘(some) tall boys’
- d. *unas niñas alt-a-s* FEM, PL, INDEF
 a.FEM.PL girls tall-FEM-PL
 ‘(some) tall girls’

My analysis of the strong-weak distinction can therefore not be used in order to render adjectival agreement in Romance compatible with the dominance requirement. It thus seems that the dominance requirement faces a real problem with respect to Romance adjectives.

Note that Romance adjectives are not only problematic for the dominance requirement. The absence of a strong-weak distinction on Romance adjectives also poses a serious challenge to my analysis of the strong-weak distinction. Why do Romance adjectives not display a strong-weak distinction like their Germanic counterparts? Below, I will show that the answer to this question also resolves the problem for the dominance requirement that is posed by adjectival agreement in Romance.

3.2. The adjunction site of attributive adjectives in Romance

As stated above, Romance attributive adjectives do not display a strong-weak distinction. They always fully agree in gender and number with the noun they modify regardless of the kind of DP they occur in, as shown in (7) and (9) above. Romance attributive adjectives are thus different from their Germanic counterparts in that there are no contexts in which they lack agreement or display partial agreement. Put differently, Romance attributive adjectives never display weak adjectival inflection. In order to account for the lack of weak adjectival inflection in Romance, I will first briefly recapitulate my analysis of weak adjectival inflection introduced in chapters 4 and 5.

Under this analysis, weak adjectival inflection arises as a result of the deactivation of D as a Probe, the adjunction of A to DP, and internal merge of D. Agree between D and N, as in (10a), deactivates D as a Probe. When the adjective is merged as an adjunct to DP, D can therefore not enter into an Agree relation with A (10b). The adjunction of A to DP triggers internal merge of D. The copy of D that is created by this instance of internal merge is also a deactivated Probe, just like the original copy of D. Because it is deactivated, the higher D-copy always constitutes a closer Goal for DP-external Probes than A. DP-external Probes can therefore not enter into an Agree relation with A, (10c).

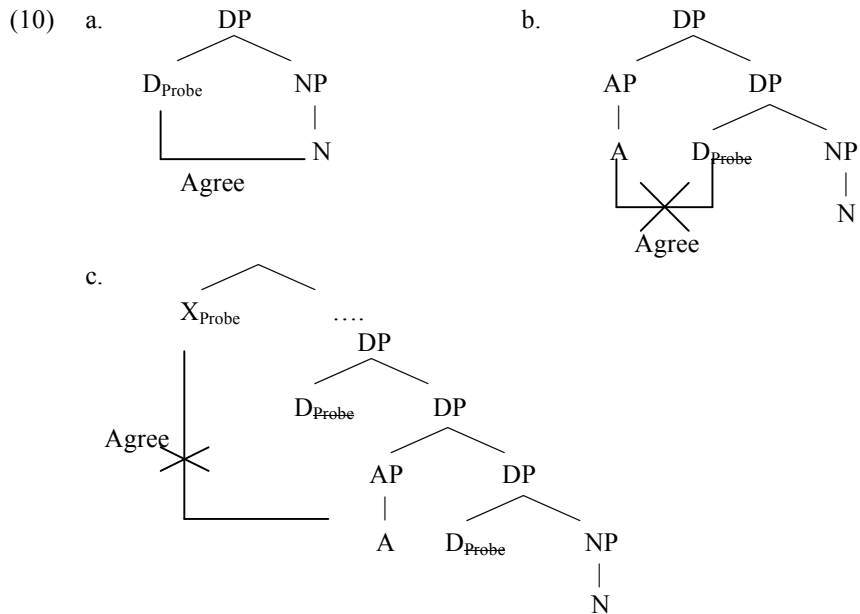

In this way, A does not enter into an Agree relation. As a consequence, Indirect Agree between A and N is not licensed. This is then spelled out on the adjective as weak adjectival inflection.

Under this analysis, adjunction of the adjective to DP plays an essential role. It ensures that D is already deactivated as a Probe when A is merged. As a consequence, D cannot enter into an Agree relation with A. If the adjective were not adjoined as high as the DP-level, things would be different. In that case, D would enter into Agree with A. That would eventually lead to feature sharing between A and N, as a result of Indirect Agree, and thus to strong adjectival inflection. I illustrate this below for the gender feature, but it would also hold for case and number features. Consider the structure in (11). In (11), the adjective is not adjoined to DP. Instead, it is adjoined lower, somewhere between D and NP.

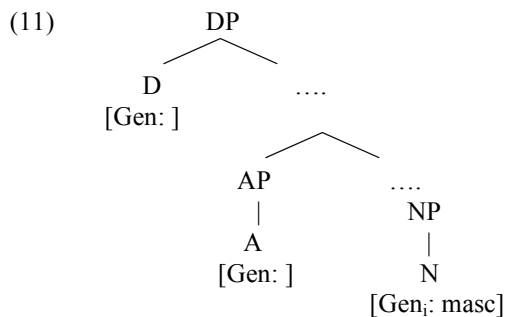

In (11), N is specified as masculine for gender, while D and A are gender Probes and thus have an underspecified gender feature. A fails to enter into a direct Agree relation with N, since the dominance requirement is not met (see chapters 3 and 4). When D probes in (11), it first finds A. A is a suitable goal for D as it has an underspecified gender feature by virtue of being a gender Probe. Hence, Agree between D and A is established. This is indicated as *Agree 1* in (12). As a result of this instance of Agree, D and A share an underspecified gender feature. Given the underspecification of the shared feature, this instance of Agree does not deactivate D as a Probe. D will therefore continue its search for a Goal. It will then find N. N has a fully specified gender feature and is therefore a suitable Goal. Hence, Agree between D and N is established (*Agree 2* in (12)). As a result of this, D is associated with the fully specified gender feature on N. Since D already shares gender with A, this means that A is also associated with the fully specified gender feature of N (Indirect Agree), as shown in (12).

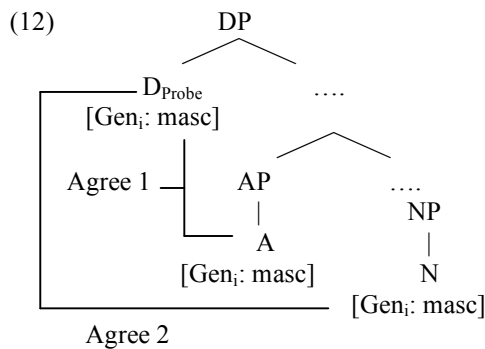

This illustration shows that the adjective would always display full agreement with N in case the adjective were adjoined at a position that is lower than D. In that case, there would be no weak adjectival inflection. Hence, adjoining adjectives to a position lower than the DP-level yields the wrong result for those Germanic languages that display a strong-weak distinction. It is therefore crucial for my account of weak adjectival inflection that attributive adjectives are adjoined to the DP level and not lower.

However, adjoining attributive adjectives at a lower level than the DP level would yield exactly the correct result for the Romance languages, which lack weak adjectival inflection. I therefore propose that the difference between the Romance and Germanic languages with respect to the strong-weak distinction is caused by a different adjunction site for attributive adjectives in the two language groups. In Germanic, attributive adjectives are adjoined to DP, as in (10). This causes the strong-weak distinction in the way described in chapters 3 and 4. In the Romance languages, the attributive adjectives are adjoined lower than their Germanic counterparts, as in (11). As shown above, this ensures that adjectives always fully agree with N yielding the absence of a strong-weak distinction.

3.3. The adjunction of attributive adjectives and word markers

Without an independently motivated account for different adjunction sites in Romance and Germanic, the proposal that the absence of a strong-weak distinction in Romance is due to low adjunction of the adjective would of course be a mere stipulation.² Below, I argue that the difference adjunction sites should be attributed to a difference between Romance and Germanic with respect to a particular type of nominal suffixes, named *word markers* (Harris 1985, 1991). In this section, I will first show that there is a correlation between the presence of word markers and the absence of weak adjectival inflection. The main argument for this comes from West Flemish. West Flemish is a Germanic variety that resembles the Romance languages in two respects. First, it lacks a strong-weak distinction for adjectival agreement. Second, it has word markers. I will then argue that the presence of word markers enables low adjunction of attributive adjectives. In the Germanic languages that display a strong-weak distinction, word markers are absent. As a consequence, low adjunction of attributive adjectives is not licensed. Given my proposal of the previous section, this results in adjectival agreement displaying a strong-weak distinction in languages without word markers, but not in languages in which nouns can take word markers.

3.3.1. The lack of weak adjectival inflection in West Flemish

In addition to the lack weak adjectival inflection, DPs containing attributive adjectives in Romance differ from their Germanic counterparts in a number of different ways. In order to illustrate this, I will briefly discuss two aspects in which Romance differs from Germanic. The first aspect concerns the order between attributive adjectives with respect to the noun. Attributive adjectives in Romance predominantly follow the noun, as shown in (13a) for Spanish. In Germanic, they precede the noun, as illustrated in (13b) for German. The second aspect has to do with the number of agreement morphemes that an adjective can take. In most Romance languages, adjectives can occur with two different suffixes: one expressing gender agreement and one expressing number agreement. This is illustrated in (13a) for the Spanish adjective *alt-* ‘tall’. In (13a), *alt-* ‘tall’ takes two suffixes: *-o*, expressing agreement in masculine gender, and *-s*, which signals agreement in plural number. In Germanic, adjectives only can take a single suffix.

² In chapter 2, I motivated the adjunction site of Germanic attributive adjectives through means of late adjunction and the phasehood of DP. On the late adjunction view (Stepanov 2001), adjuncts, like attributive adjectives, are merged just before the syntactic derivation is shipped off to the interfaces. Syntactic derivations are shipped off to the interfaces in phases (Chomsky 2001). DP is a phase in Germanic (Heck & Zimmermann 2004 among others). Hence, attributive adjectives are adjoined to DP in Germanic. On this account, attributive adjectives can only be adjoined to a lower level than DP in Romance, if a constituent below DP constitutes a phase in Romance. However, I did not find any indication that this is the case. The phase-based motivation is therefore incompatible with my proposal that attributive adjectives are adjoined at different levels in Romance and Germanic. I will therefore abandon it here. Instead, I propose below that the adjunction site of attributive adjectives depends on the presence on whether a particular nominal suffix, a word marker, is present or not.

This single suffix can however express agreement in more than one feature, i.e. it is a portmanteau morpheme. The German adjective *groß* ‘tall’ in (13b) for instance only takes the *-e* ending which signals agreement in number and case.

- (13) a. *unos* *niñ-o-s* *alt-o-s* SPANISH: N > ADJ
 a.MASC.PL boy-WORDMARKER-PL tall-MASC-PL
 ‘(some) tall boys’
- b. *gross-e* *Junge-n* GERMAN: ADJ > N
 tall-PL.NOM/ACC boys
 ‘tall boys’

In addition to these two differences, DPs in the two language groups also differ in other respects. In Romance, plural indefinite DPs are for instance introduced by an article, *unos* in (13a), while plural indefinite DPs in Germanic are not (13b). Another difference is that Romance has word markers, i.e. nominal suffixes whose form generally correlates with the grammatical gender of the noun³ (*-o* in (13a)), while Germanic does not have word markers (more on word markers below). Given that there are multiple aspects in which DPs that contain an adjective differ in Romance and Germanic, it is difficult to pinpoint which difference is responsible for the different adjunction sites for attributive adjectives in Germanic and Romance.

Fortunately, there is a Germanic variety that can help in diagnosing the factor that causes this difference. This variety is West Flemish as spoken in the Belgian village of Lapscheure.⁴ As pointed out to me by Liliane Haegeman (personal communication), attributive adjectives in West Flemish agree in gender and number with the noun they modify. Unlike most other Germanic varieties⁵, West Flemish has no strong-weak distinction. The agreement on the adjective is not influenced by the article of the DP in which the adjective occurs. This is illustrated by the data in (14) and (15), provided to me by Liliane Haegeman (personal communication). The adjectival inflection in the definite DPs in (14) is identical to that in the indefinite DPs in (15).⁶

- (14) a. *den* *nieuw-en* *hond* DEF, MASC, SG
 the.MASC.SG new-MASC.SG dog
 ‘the new dog’

³ Although there are exceptions, see section 3.3.5 below.

⁴ West Flemish is a group of Dutch dialects mainly spoken in the most western part of Belgium, but also in the *Zeeuws-Vlaanderen* region in Holland, and in the *département du Nord* in Northern France. Lapscheure is a Belgian village situated approximately 14 kilometers to the northeast of Bruges, near the border between Belgium and The Netherlands.

⁵ The group of Germanic languages in which the adjectival inflection displays a strong-weak distinction consists of the languages studied in chapters 4 and 5 (Swedish, Norwegian, Danish, German, and Dutch) and of Icelandic, Faroese, and Yiddish. In English, attributive adjectives do not agree at all. As a consequence, English does not have a strong-weak distinction.

⁶ Yves d’Hulst (personal communication) wonders whether the *-en* suffix on adjectives modifying *hond* is the result of liaison. This is, however, irrelevant for the present discussion. The important thing to notice is that there is no strong-weak distinction in West Flemish.

- | | | | | | |
|------|----|-------------------------------------------------|--------------------------------|--------------------------|-----------------|
| | b. | <i>de</i>
the.FEM.SG
'the new cat' | <i>nieuw-e</i>
new-FEM.SG | <i>katte</i>
cat | DEF, FEM, SG |
| | c. | <i>et</i>
the.NEUT.SG
'the new small cat' | <i>nieuw-Ø</i>
new-NEUT.SG | <i>kat-je</i>
cat-DIM | DEF, NEUTER, SG |
| (15) | a. | <i>nen</i>
a.MASC.SG
'a new dog' | <i>nieuw-en</i>
new-MASC.SG | <i>hond</i>
dog | INDEF, MASC, SG |
| | b. | <i>een</i>
a .FEM.SG
' a new cat' | <i>nieuw-e</i>
new-FEM.SG | <i>katte</i>
cat | INDEF, FEM, SG |
| | c. | <i>een</i>
a.NEUT.SG
'a new small cat' | <i>nieuw-Ø</i>
new-NEUT.SG | <i>katje</i>
cat-DIM | INDEF, NEUT, SG |

Attributive adjectives in West Flemish thus share with their Romance counterparts the property of displaying agreement without a strong-weak distinction. This property sets West Flemish apart from the other Germanic varieties which either have a strong-weak distinction or lack adjectival agreement altogether (see footnote 5). Under my proposal of section 3.2, the absence of a strong-weak distinction in West Flemish would mean that attributive adjectives are adjoined to some lower level than DP, just like in the Romance languages. Since West Flemish is a Germanic variety, it can help to determine which characteristic of Romance DPs licenses low adjunction of attributive adjectives. If DPs with attributive adjectives in West Flemish share with their Romance counterparts another property that is absent in other Germanic varieties, this property is most likely the cause of the low adjunction and hence of the absence of the strong-weak distinction. West Flemish and Romance indeed share such a characteristic. As pointed by Haegeman (2000) and Haegeman & Van Peteghem (2002), nouns in West Flemish and the Romance languages can take a suffix of which the form seems to be dependent on the gender of the noun. These suffixes are called *word markers* (Harris 1991; Bernstein 1993) and are absent in Germanic languages other than West Flemish. I claim that the presence of word markers in a language licenses low adjunction of attributive adjectives. As shown above, this low adjunction then causes the lack of weak adjectival inflection. In this way, the presence of word markers in a language causes the absence of a strong-weak distinction for adjectival agreement.

3.3.2. Word markers in Romance and West Flemish

I claimed above that West Flemish and Romance both have word markers on nouns. Before examining the syntactic representation of word markers in Romance and West Flemish and how they license low adjunction of attributive adjectives, I first will introduce the term word marker in some more detail and show how word markers are distributed in Romance and West Flemish.

The term *word marker* was introduced by Harris (1985,1991). Harris (1991) uses the term for a group of suffixes in Spanish that mark “a derivationally and inflectionally complete word; word markers cannot be followed by any other suffix, derivational or inflectional, except for plural *-s*” (Harris 1990: 30). The most salient characteristic of word markers is that their form is related to gender. A particular word marker almost exclusively occurs on elements that carry a particular gender. For instance, Spanish nouns that end in the word marker *-o* are predominantly masculine, while those that take the word marker *-a* are mostly feminine. This is shown in (16) for animate nouns and in (17) for inanimate nouns. The word markers in these examples are indicated by boldface.

(16)	MASCULINE		FEMININE	
a.	<i>muchacho</i>	a.ʹ	<i>muchacha</i>	
	‘boy’		‘girl’	
b.	<i>abuelo</i>	b.ʹ	<i>abuela</i>	
	‘grandfather’		‘grandmother’	
c.	<i>nieto</i>	c.ʹ	<i>nieta</i>	
	‘grandson’		‘granddaughter’	
d.	<i>tío</i>	d.ʹ	<i>tía</i>	
	‘uncle’		‘aunt’	(Harris 1991: 27, ex 1)

(17)	MASCULINE		FEMININE	
a.	<i>domicilio</i>	a.ʹ	<i>residencia</i>	
	‘home’		‘residence’	
b.	<i>asiento</i>	b.ʹ	<i>silla</i>	
	‘seat’		‘chair’	
c.	<i>libro</i>	c.ʹ	<i>libra</i>	
	‘book’		‘pound’	
d.	<i>caso</i>	d.ʹ	<i>casa</i>	
	‘case’		‘house’	(Harris 1991: 36, ex 11)

There are some exceptional cases in which a word marker occurs on a word that carries a different gender than the other elements on which it occurs. I will come back to these exceptions in section 3.3.5 below. In Spanish, word markers can occur on different elements. As shown by Harris, they occur on nouns, pronouns, adjectives, and adverbs. In this chapter, I will only be concerned with the presence of word markers on nouns.

Bernstein (1993) argues that word markers are not a language particular property of Spanish. Instead, she claims that word markers are a general characteristic of the Romance languages. In order to motivate her claim, she shows that a variety of Romance languages have nominal endings that are related to gender, just like the Spanish word markers. Consider for instance briefly Italian, Catalan and French. In Italian, just like in Spanish, nouns with an *-o* ending are for instance mostly masculine, while nouns ending in *-a* are predominantly feminine. This is illustrated in (18).

- | | | | | |
|------|----------------|--|----------------|----------------------|
| (18) | MASCULINE | | FEMININE | |
| | <i>ragazzo</i> | | <i>ragazza</i> | |
| | 'boy' | | 'girl' | (Bernstein 1993:122) |

-o and *-a* are therefore not only word markers in Spanish, but also in Italian.

In Catalan, nouns without an ending are predominantly masculine, while nouns that end in *-a* are mostly feminine. This is illustrated in (19).

- | | | | | |
|------|----|--------------------|-----|-------------------------------------|
| (19) | a. | MASCULINE | a.' | FEMININE |
| | | <i>el promès</i> | | <i>la promessa</i> |
| | | the.MASC.SG fiancé | | the.FEM.SG fiancée |
| | | 'the fiancé' | | 'the fiancée' |
| | b. | <i>el mercat</i> | b.' | <i>la llibreta</i> |
| | | the.MASC.SG market | | the.FEM.SG notebook |
| | | 'the market' | | 'the notebook' (Bernstein 1993:139) |

The *-a* ending is therefore a word marker in Catalan.

In French, nouns that end in an *-e* in writing are predominantly feminine, while nouns that do not take an ending are mostly masculine. This is illustrated by the minimal pairs in (20).

- | | | | | |
|------|----|---------------|-----|--------------------------------------|
| (20) | | MASCULINE | | FEMININE |
| | a. | <i>voisin</i> | a.' | <i>voisine</i> |
| | | 'neighbor' | | 'neighbor' |
| | b. | <i>cousin</i> | b.' | <i>cousine</i> |
| | | 'cousin' | | 'cousin' |
| | c. | <i>chat</i> | c.' | <i>chatte</i> |
| | | 'cat' | | '(female) cat' (Bernstein 1993: 138) |

It therefore seems that the French *-e* ending is a word marker. However, there is a complication. The *-e* ending exclusively occurs in writing. It is not pronounced in spoken French. However, this does not mean that the nouns with an *-e* ending in (20a'-c') are pronounced in the same way as their counterparts without this ending in (20a-c). Nouns that are written without the *-e* ending are pronounced without the final consonant, e.g. *chat* 'cat' is pronounced as [ʃɑ] not as [ʃɑt]. This final consonant is pronounced when nouns take the *-e* ending in writing, e.g. *chatte* 'female cat' is pronounced as [ʃɑt] not as [ʃɑ]. Following Schane (1968), Bernstein (1993) argues that the absence of final consonant deletion in the forms that end in *-e* in written French is due to the presence of this ending in the underlying representation of the word in question. On this view, French has thus also an ending that seems to be related to the gender of the noun on which it occurs, i.e. a word marker. This word marker is however not pronounced, but its presence causes an effect on the surface form of a word by preventing final consonant deletion.

The Romance languages are not the only languages that display word markers. Haegeman (2000) and Haegeman & Van Peteghem (2002) claim that West Flemish also has word markers. They motivate this claim by showing that the *-e* ending that occurs on some West Flemish nouns is related to feminine gender. The

large majority of nouns on which the *-e* ending occurs are feminine. This is illustrated for a number of nouns in (21).

(21)	MASCULINE		FEMININE	
a.	<i>zot</i>		a.’ <i>zotte</i>	
	‘fool’		‘fool’	
b.	<i>bar</i>		b.’ <i>barre</i>	
	‘bar/pub’		‘beam’	
c.	<i>bom</i>		c.’ <i>bomme</i>	
	‘bottom’		‘bomb’	
d.	<i>eerd</i>		d.’ <i>eerde</i>	
	‘fireplace’		‘earth’	Haegeman (2000: 125)

No other Germanic variety except West Flemish has word markers. Hence, there are two aspects in which West Flemish is similar to Romance, but different from the other Germanic languages. First, adjectival inflection in West Flemish does not display a strong-weak distinction. Second, West Flemish has nominal word markers. Thus, the crosslinguistic distribution of the strong-weak distinction in Germanic and Romance seems to be correlated with the crosslinguistic distribution of word markers. A language in which nouns can take word markers does not display a strong-weak distinction on the inflection of attributive adjectives. This correlation is schematized in the table in (22a), and formulated in (22b).

(22) a. WORD MARKERS AND STRONG-WEAK INFLECTION

Languages	Word marker	Strong-weak adjectival inflection
Romance	+	-
Lapscheure West Flemish	+	-
Other Germanic languages	-	+ ⁷

b. CORRELATION BETWEEN WORD MARKERS AND STRONG-WEAK AGREEMENT

In the Romance and Germanic languages:

- I. If nouns in a language can take word markers, attributive adjectives do not display a distinction between strong and weak inflection.
- II. If nouns in a language cannot take word markers, attributive adjectives display a distinction between strong and weak inflection.

Below, I will argue that this correlation receives a straightforward explanation if word markers license low adjunction of attributive adjectives. Before I can do show

⁷ With the exception of English. As stated in footnote 5, this languages does not display adjectival agreement at all. For this reason, it is not relevant for the present discussion.

this in more details, I first have to introduce the role of word markers in the grammar.

3.3.3. The role of word markers in the grammar

Bernstein (1993) and Picallo (2005) claim that word markers on nouns are syntactically represented as a functional head that is merged with N.⁸ I follow Bernstein (1993) by calling this functional head *WM* for Word Marker.⁹ WM is merged directly with N, thus before any other elements, like adjectives or determiners are merged. On this view, the Spanish DP in (23a) has the structure in (23b) at the point of the derivation where narrow syntax and Vocabulary Insertion have taken place.

- (23) a. *el niño-o* [Spanish]
 the.MASC child-WM.MASC
 ‘the boy’
- b.
-
- ```

graph TD
 DP --> D[el]
 DP --> WMP
 WMP --> WM[-o]
 WMP --> NP
 NP --> N[niñ-]

```

Note that the word marker *-o* that occurs on *niño* ‘boy’ is inserted in WM and not on N. I abstract away in (23b) and in what follows from the way in which word markers are combined with the nominal stem. This combination might be achieved either by head movement in narrow syntax or by Local Dislocation (see chapter 2) in the morphological component.

Picallo (2005) proposes that the semantic function of the functional head associated to the word marker is to categorize the entity denoted by the noun. On her view, the word marker thus functions more or less like a classifier. Picallo proposes that this categorization function is the result of gender being interpretable at the CI-interface at the WM-node. However, she claims that WM is not endowed with a fully specified gender feature of its own. Instead, she takes WM to be a gender

<sup>8</sup> The main motivation for Bernstein (1993) to represent word markers as functional heads in syntax is that she claims that they license different syntactic phenomena like the Romance postnominal position of adjectives and noun ellipsis. However, Haegeman (2000) shows that there are good reasons to believe that word markers do not play a role in the licensing of these phenomena. In the distributed morphology model of the grammar I adopted, there is however another good reason to represent word markers as syntactic heads. The systematic relation between gender and the form of the word marker suggest that they are (inflectional) morphemes. On the distributed morphology view of the grammar, such morphemes are inserted postsyntactically in terminal nodes of the syntactic structure. In this model of the grammar, the null hypothesis is therefore that word markers are syntactic terminal nodes, i.e. heads.

<sup>9</sup> Picallo (2005) calls it *c* for Categorization. She does this because she takes the function of the word marker to be categorizing entities. I will discuss this function below.

Probe that enters into an Agree relation with a fully specified, but uninterpretable, gender feature on N. This Agree relation is schematized in (24).<sup>10</sup>

(24) ROMANCE AND WEST FLEMISH

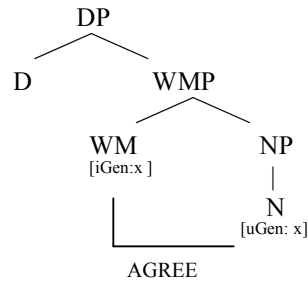

If word markers have the function of categorizing the entity denoted by N as proposed by Picallo (2005), the question arises how is this function performed in languages that lack word markers, like the majority of the Germanic languages. As stated above, WM performs this categorization function by virtue of having probing gender features that are interpretable at the CI-interface. Hence, languages that do not have word markers, and therefore also lack WM, should have another element on which gender is interpretable at the CI-interface. For the Germanic languages, with the exception of West Flemish, I propose that this element is D. More precisely, I propose that the Germanic D has probing gender features that are interpretable at the CI-interface, just like WM in the Romance languages and West-Flemish. In that way, D performs the task that is done by WM in Romance. In narrow syntax, it enters into an Agree relation with the fully specified, but uninterpretable gender features on N, as in (25).<sup>11</sup>

(25) GERMANIC (MINUS WEST FLEMISH)

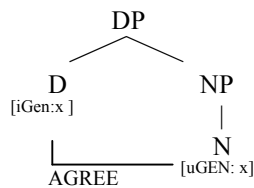

<sup>10</sup> The gender feature that participates in Agree is thus CI-interpretable on the Probe, WM, and not on the Goal, N (cf. Pesetsky & Torrego 2004). Note that the possibility that features that participate in an Agree relation are CI-interpretable on the Probe, instead of on the Goal, is fully compatible with the view on Agree that I proposed in chapter 4. The reason for this is that I defined probehood in terms of underspecification, independently of CI-interpretability.

<sup>11</sup> In chapters 4 and 5, I assumed that gender is interpretable on N, while being uninterpretable on D. However, adopting the view that gender is interpretable on D and uninterpretable on N has no consequences for the analysis presented in chapters 4 and 5.

In the semantic component, the interpretable and now fully specified gender features on D are then interpreted as performing categorization of the entity denoted by N.

The differences between languages with word markers and languages without them thus concern the presence of WM and the issue of the head on which gender is interpretable. In the Germanic languages without word markers, WM is lacking and D has an interpretable gender feature. In the languages with word markers, i.e. Romance and West Flemish, WM is present and has an interpretable gender feature. As a consequence of these differences, the adjunction site of attributive adjectives is different in the two groups of languages. In order to appreciate this, first consider the languages with word markers.

According to Bernstein (1993) and Picallo (2005), WM is merged with (a projection of) N before elements like adjectives and determiners are merged. The motivation for this is morphological. Word markers are adjacent to the nominal stem and it is a natural assumption that this reflects syntactic closeness of N and WM.<sup>12</sup> However, this is of course a mere translation of a morphological observation into syntactic terms. It does not offer a real explanation for the close association between word markers and the nominal stem. This close association is likely to be caused by the categorization function of word markers.<sup>13</sup> If, from a semantic viewpoint, categorization of the entity denoted by N is required to take place prior to adjectival modification or determination of this entity, then there is no other option than to merge WM before adjectives and determiners are merged. Unfortunately, I do not have the space here to investigate this direction of research in more detail. For the moment, I will simply adopt the working hypothesis that something in the categorization function of word markers forces them to be merged with (some projection of N) before other elements are merged. This working hypothesis is formulated in (26).

- (26) CATEGORIZATION FIRST  
 Categorizing an entity denoted by N needs to take place before modification and further determination of the entity denoted by N. A syntactic object with an interpretable gender feature is therefore merged with N before adjectival adjuncts or determiners.

In the Romance languages and West Flemish, the working hypothesis in (26) excludes adjectives from being merged before WM. However, it does not have anything to say about whether adjectives should be merged directly after WM is merged or later on in the derivation when other elements have been merged. For instance, both the structure in (27a), in which the adjective is adjoined to WMP, and the structure in (27b), in which the adjective is adjoined to DP, comply with (26).

---

<sup>12</sup> Merging WM directly with (a projection of) N is needed both on a syntactic account (head movement) or a morphological account (Local Dislocation) of the suffixation of the word marker onto N. On the syntactic account, the head movement constraint would prohibit any other (overt) head from intervening between WM and N. On the local dislocation account any other (overt) syntactic object (head or phrase) is banned from intervening between WM and N.

<sup>13</sup> Note that it is still unclear how the details of categorizing function of Word Markers should be defined semantically. However, it is clear that it should happen before modifiers get attached.

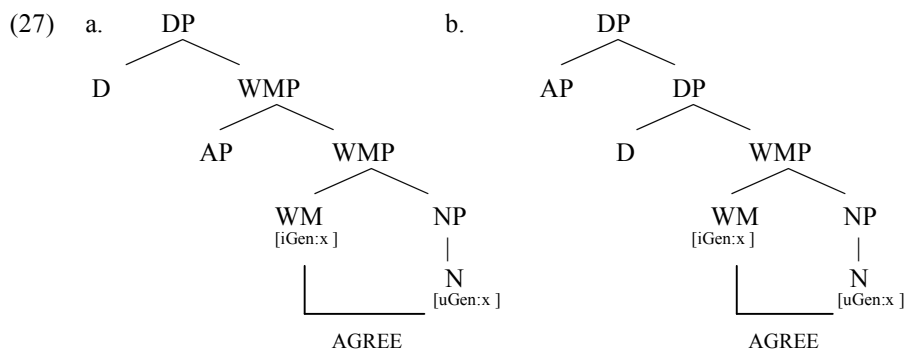

Although it complies with (26), merging the adjective above D as in (27b) is excluded because of economy considerations. Merging the adjective after D would put the adjective outside the domain of the definite D. As shown in chapter two, this causes a type mismatch that needs to be repaired. In chapter 2, I argued for the Germanic languages that this is accomplished by internal merge of D. Hence, adjoining the adjective to DP as in (27b) would trigger the additional syntactic operation of internal merge. However, internal merge of D is not needed if the adjective is adjoined before D is merged, as for instance in (27a). In that case, the adjective ends up in the semantic domain of the definite D. As a consequence, no type mismatch is created and therefore no internal merge is triggered. Put differently, adjoining the adjective as in (27a) does not trigger additional operations in narrow syntax. As a result, the derivation involves less syntactic operations in case the adjective is adjoined before D is merged than if it is merged later. Hence, adjoining the adjective below D, as in (27a) is preferred over adjoining it above D as in (27b) because of economy. Given this and the working hypothesis in (26), adjectives in Romance are merged after WM, but before D, as in (27a).

Merging the adjective before D is merged is however not an option in the Germanic languages other than West Flemish. In view of the lack of word markers in these languages, I propose that D, instead of WM, performs the function of categorizing the entity denoted by the noun by virtue of gender being interpreted on it. Given the constraint that categorization needs to precede modification (see (26)), there is no other option than to adjoin the adjective after D is merged. Merging the adjective before D would violate (26), since modification by the adjective would then precede the categorization performed by D. As shown in chapter 2, adjoining the adjective after D triggers internal merge of D, as in (28).<sup>14</sup>

<sup>14</sup>This internal merge was triggered because of a type mismatch that was created by adjoining the adjective outside the domain of D. I argued in chapter 2 that this type mismatch is then repaired by deleting the lower D-copy at the CI-interface. However, I just claimed that the lower D-copy performs the function of categorization by virtue of interpreting gender at the CI-interface. Hence, deletion should be scattered. Gender should be deleted at the higher copy, not at the lower one. Those features that are responsible for type shifting the DP to type <e> (definiteness, referentiality, etc) should however be deleted on the lower copy and not on the higher one.



(28)

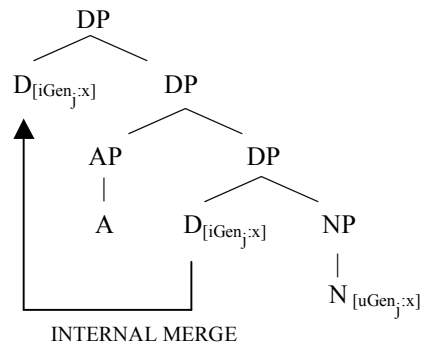

The derivation of DPs in the Germanic languages thus involves internal merge of D, while this is not the case for the Romance languages. This is an immediate consequence of the fact that the Romance languages have word markers, while the Germanic languages do not. In the Romance languages, interpretable gender on WM, the head associated with word markers, allows adjectives to adjoin in between WM and D. In the Germanic languages, there are no separate word markers. Instead D has interpretable gender in order to perform the function of word markers in addition to its normal functions. In order to observe the constraint that categorization precedes modification, adjectives have to be merged after D. However, this triggers the additional operation of internal merge of D. These different derivations for Romance and Germanic are shown in (29).

(29) a. ROMANCE & WEST FLEMISH                      b. GERMANIC LANGUAGES (MINUS WEST FLEMISH)

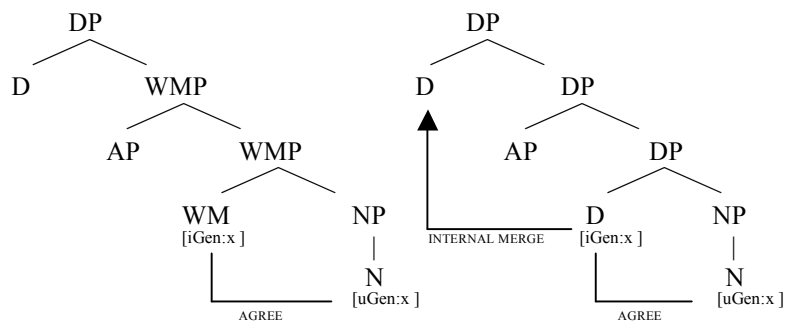

In this way, the presence of word markers in Romance and West Flemish ensures that the derivation of DPs containing adjectives differs in these languages from that in the Germanic languages that lack word markers. This offers an explanation for the distribution of the strong-weak distinction in the Romance and the Germanic languages. In chapters 4 and 5, I showed that the derivation in (29b), and especially the adjunction of AP to DP and internal merge of D, gives rise to the strong-weak distinction. Since this derivation is the consequence of the lack of word markers, the presence of the strong-weak distinction in the majority of the Germanic languages is in this manner attributed to the absence of word markers in these languages. In

section 3.2, I argued that adjoining the adjective below D ensures that strong adjectival inflection is always licensed. Put differently, such an adjunction causes the absence of a strong-weak distinction for adjectival inflection. I just argued that the presence of word markers in Romance and West Flemish causes adjunction of the adjective below D, as in (29a). In this way, the absence of a strong-weak distinction on the adjectival inflection in Romance and West Flemish is accounted for by the presence of word markers in these languages. Below, I will illustrate this account for the absence of weak adjectival inflection in the Romance languages by providing the derivation of a Spanish definite DP that contains an adjective.

### 3.3.4. Illustration of the account

I will now provide the derivation of the Spanish plural feminine definite DP in (30), to illustrate my proposal that the presence of word markers is the cause of the absence of weak adjectival inflection in Romance and West Flemish.<sup>15</sup>

- (30) *las buenas personas* FEM, PL, DEF  
 the.FEM.PL good-FEM-PL persons  
 ‘the nice/good people’

The first step in the derivation is to merge WM, the head that hosts the word marker and N. Given that WM is a gender Probe (see the previous section), it will enter into an Agree relation with N. This results in the sharing of a gender feature between WM and N, as in (31).

- (31) STEP #1: MERGE & AGREE (WM,N)

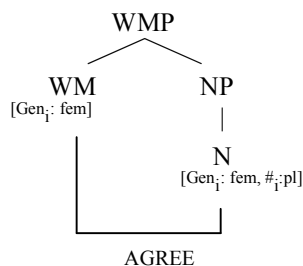

The next step is to adjoin the adjective. As argued in the previous section, adjoining the adjective has to take place after WM is merged because categorization needs to precede modification, cf (26). However, I claimed that it has to take place before D is merged, because of economy reasons. I will assume here that it is adjoined to

<sup>15</sup> Most of the adjectives in Spanish occur in postnominal position (see for instance the data in (7) above). In order to not unnecessarily complicate the illustration of my proposal, I will abstract away from this. I therefore illustrate my proposal with *bueno* ‘good/nice’, one of the few adjectives that occur prenominal in Spanish.

WMP.<sup>16</sup> The Spanish adjective is a gender and number Probe. However no Agree can be established because the dominance requirement on Agree is not met given that the adjectival Probe is an adjunct. Hence, the derivation continues without A participating in any feature sharing, as in (32).

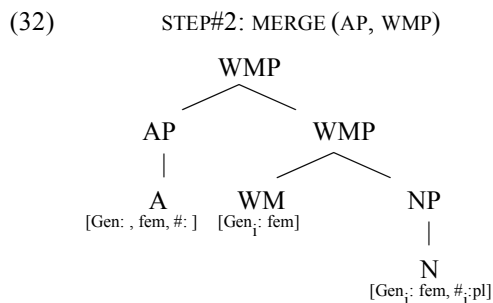

After the adjunction of the adjective, D is merged. Spanish articles display gender and number agreement with the noun they modify. They are thus gender and number Probes. D will therefore look down its search domain and look for elements with gender and number features. The first element that it finds is the adjective.<sup>17</sup> It will therefore enter into an Agree relation with the adjective, resulting in the sharing of unvalued gender and number features between A and D, as in (33).

<sup>16</sup> However, nothing excludes that it is adjoined to some functional projection between WM and D. Since I am not concerned here with the fine-grained structure of the nominal domain in Romance, I will leave the issue of the exact adjunction site of APs in Spanish unresolved, but simply assume that they are adjoined to WMP.

<sup>17</sup> The careful reader might object that the WMP-node immediately dominating the adjective is a closer Goal for Agree with D, at least as far as gender is concerned. As a result of Agree between WM and N (step # 1 in (31)), WM shares a valued gender feature with N. On the label-sharing view of projection, the WMP-node dominating AP is also associated to this gender feature. Hence, this WMP-node seems to constitute a closer Goal for Agree with gender than A. However, as noted in footnote 16, it is not clear whether the adjective is actually adjoined to WMP or to another functional projection between WM and D. If it were adjoined to another projection between WM and D, there would be no WM-node intervening between A and D. In that case, there would not be an intervention problem. Another possibility would be that adjunction creates unlabelled nodes as claimed by Hornstein & Nunes (2008). Under that view, adjunction of the adjective to WMP would not result in the adjective being dominated by a WMP node, hence there would be no intervention of a WMP node for Agree between D and A.

I tentatively conclude here that there is no intervener for Agree between D and A, either because the adjunction site is different or that adjunction does not create labeled nodes. However, more research is needed in order to choose between these two options. Unfortunately, more research on these issues is outside the scope of this chapter. I will therefore leave them for further research.

(33) STEP #3 MERGE (D, WMP) &amp; AGREE (D, A)

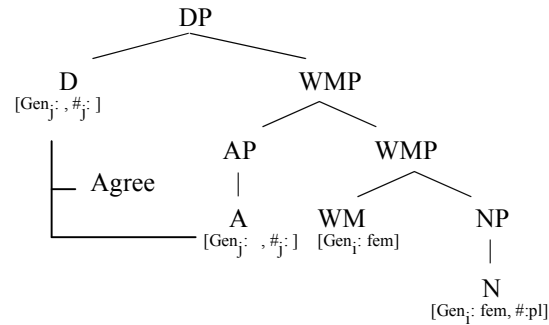

This step is the crucial difference that sets Romance and West Flemish definite DPs containing adjectives apart from their counterparts in the other Germanic languages. As I argued in chapter 4 and 5, the definite D in the Germanic languages that display a strong-weak distinction is already (partially or completely) deactivated when it is in the right configuration to establish an Agree-relation with the adjective. Hence, no (full) Agree is established by the definite D in these Germanic languages, unlike in West Flemish and Romance. As I will show below, this difference eventually leads to the absence of weak adjectival inflection in West Flemish and Romance.

Agree between D and A does not deactivate D as a Probe, since the features that are shared as a result of this instance of Agree are underspecified. D therefore probes further down its search domain. It first finds WM, which is associated with a fully specified gender feature as result of Agree between WM and N (cf. (31)). Hence, Agree is established between WM and D for gender. This does however not deactivate D as a number Probe. D will therefore continue its search. It will then find number on N. Agree between D and N is then established for number. Agree (D, WM) and Agree (D, N) associate D with the fully specified gender and number features that originated on N. Since D however already shared (underspecified) gender and number features with the adjective, feature sharing between D, WM and N also associates A with fully specified number and gender features, as shown in (34). This is an instance of Indirect Agree similar to that involved in the licensing of strong adjectival inflection.

(34) STEP #4: AGREE (D,WM) &amp; AGREE (D, N)

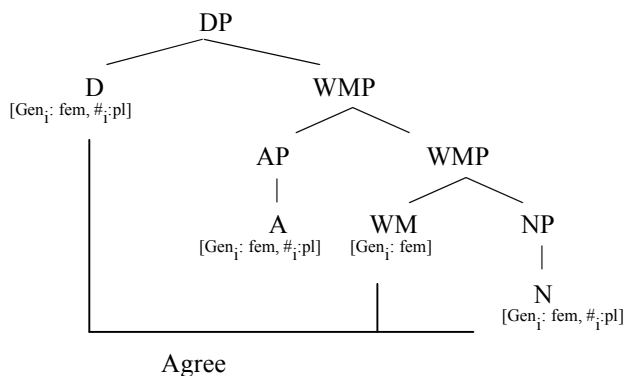

In this way, the adjective ends up sharing fully specified gender and number features in Romance and West Flemish definite DPs, unlike in their Germanic counterparts. This sharing is then spelled out in the postsyntactic morphological component as full adjectival agreement, like in (35)

(35) a. VOCABULARY INSERTION                      b. PHONOLOGICAL SPELL OUT

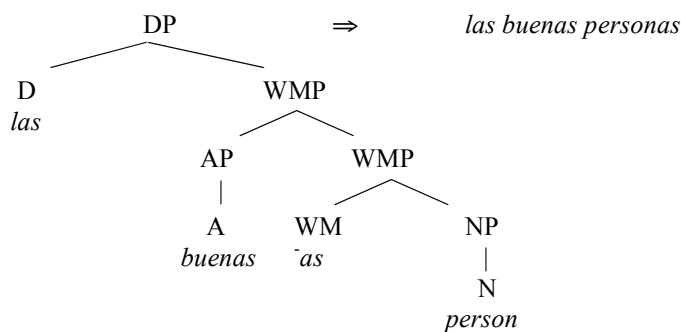

The example of Spanish illustrates the way in which full agreement is licensed on attributive adjectives in Romance and West Flemish definite DPs. Unlike their counterparts in other Germanic languages, there is no partial agreement or absence of agreement, i.e. weak adjectival inflection is not licensed.

### 3.3.5. A note on the relation between word markers and gender

In my analysis of the absence of weak adjectival inflection in Romance and West Flemish, the relation between gender and word markers plays a central role. I adopted Picallo's (2005) proposal that gender on word markers is interpretable at the CI-interface as a categorizer of the entity denoted by the noun. I then argued that this function of gender on word markers licenses adjunction of attributive adjectives below D. This low adjunction ensures that attributive adjectives always display full

agreement with the head noun, explaining in this way the absence of weak adjectival inflection. Given the important role of gender on word markers in my analysis, it is imperative that there be solid evidence that gender is present on word markers. As shown in section 3.3.2, this is indeed the case. In the vast majority of cases, the form of the word marker depends on the gender of the noun. For instance, nouns that take the word marker *-o* in Spanish are predominantly masculine, while those that take the *-a* word marker are mostly feminine (for examples see section 3.3.2). However, this relation between the form of the word marker and the gender of the noun breaks down in some exceptional cases. Consider for instance the Spanish word marker *-a*. In most cases, this word marker occurs on feminine nouns. However, it also occurs with a small collection of masculine nouns, as shown in (36).

- (36)            MASCULINE
- a.        *telegrama*  
          ‘telegram’
  - b.        *profeta*  
          ‘prophet’
  - c.        *poeta*  
          ‘poet’
- (Harris 1991: 37, ex. 13)

Another example is the Spanish word marker *-o*. This word marker also shows up on a small group of feminine nouns, while it predominantly occurs on masculine nouns. This thus constitutes another example of the relation between the form of the word marker and the gender of the noun breaking down. Some examples of feminine nouns taking the *-o* word marker are shown in (37).

- (37)            FEMININE
- a.        *dinamo*  
          ‘dynamo’
  - b.        *mano*  
          ‘hand’
  - c.        *nao*  
          ‘ship’
- (Harris 1991, 37, ex 13)

These examples show that the relation between the form of a word marker and gender is not always transparent. Does this mean that there is no solid evidence for gender being present on word markers? Following Harris (1991), I claim that the answer to this question should be negative. According to Harris (1991: 33), cases in which another word marker shows up on the noun than the one that would be expected on basis of the gender of the noun, like in (36) and (37), are extremely rare. In order to capture this observation, gender should be available on word markers. This is indeed what Harris (1991) proposes. According to him, the form of word markers is in the normal case directly determined by gender. Only in some exceptional cases, lexical properties of the nominal stem overrule the regular spell out rules of word markers based on gender. In that case, an unexpected word marker shows up, as in (36) and (37). Since gender must be available to determine the form of the word marker according to Harris, Harris’ proposal is fully compatible with

Picallo's view adopted in this chapter that word markers have (interpretable) gender. The only thing that needs to be done in order to incorporate the exceptional cases in (36) and (37) into the present analysis is transposing Harris' analysis to the framework of distributed morphology. I will now show how this can be done.

In the distributed morphology model of the grammar that I adopted, this intuition can be resolved by making vocabulary insertion in WM sensitive to two different elements. The first element is the gender feature WM is associated with, as a result of Agree between WM and N (see the previous section). The second element is the vocabulary item inserted in N. In the normal case, like *muchacho* in (38a), WM enters into an Agree relation in narrow syntax with N for gender. This associates WM with a gender feature, like in (38b). This gender feature is then spelled out as the word marker that transparently marks the gender (-o for masculine, -a for feminine), like in (38c).

- (38) a. *muchacho*  
'boy'  
b. OUTCOME NARROW SYNTAX

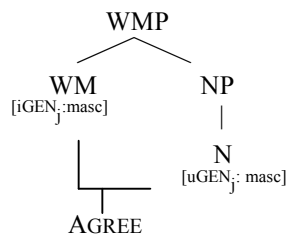

- c. VOCABULARY INSERTION FOR WM  
[Gen: masc] → -o

In the exceptional cases, WM is also associated with the gender feature of N via Agree in narrow syntax. At Vocabulary Insertion, the general rules that spell out the gender feature is however blocked by the subset principle as a result of the presence of a more specific rule. This more specific rule states that the gender feature on WM should be spelled out in a particular way in the context of a particular noun inserted in N. This happens for instance in the case of *profeta* 'prophet', in (39).

- (39) a. *profeta*  
'prophet'

## b. OUTCOME NARROW SYNTAX

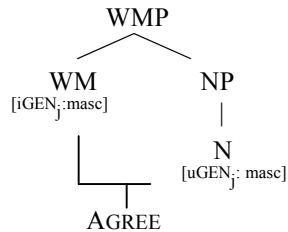

## c. VOCABULARY INSERTION FOR WM

[gen:masc]/[N profet] → /a/

In this way, the word marker is normally spelled out on the basis of the gender feature on WM (which is licensed through Agree in syntax), but in some exceptional cases the VI inserted in N overrules this. In this way, the exceptional cases in (36) and (37) are incorporated in the present analysis. Moreover, this account of the spell-out of word markers is crucially dependent on gender being present on WM. Hence, it is fully compatible with my analysis of the absence of the strong-weak distinction in Romance and West Flemish.

### 3.4. Back to the predicative/attributive adjectival agreement symmetry

I now have introduced a principled account for the absence of a strong and weak distinction on the inflection of attributive adjectives in Romance and West Flemish. These languages lack such a distinction because they have word markers. These word markers license adjunction of attributive adjectives below D. This low adjunction ensures that attributive adjectives in these languages always fully agree with N, which yields the absence of a strong-weak distinction. However, the main topic of this chapter is not the absence of the strong-weak distinction in Romance and West Flemish, but the problems for the dominance requirement discussed in chapter 3. Attributive adjectives in Romance posed a problem for this requirement. The reason for this is that they display agreement with the noun they modify, as in (40).

- (40) *las*                      *niñas alt-a-s*                                      FEM, PL, ATTR  
 the.FEM.PL              girls tall-FEM-PL  
 ‘the tall girls’

In chapter 3, I argued that this agreement is not predicted by the dominance requirement since no projection of the adjective dominates the noun. However, the agreement pattern on Romance attributive adjectives ceases to constitute a problem for the dominance condition on Agree under my analysis of the absence of a strong-weak distinction in Romance. This is so because the licensing of agreement on Romance attributive adjectives is not the result of a direct Agree relation between the adjective and the noun. Instead, I claim that this licensing is the result of D first



entering into an Agree relation with A and then with N and WM, as in (41). I refer the reader for a detailed discussion to section 3.3.

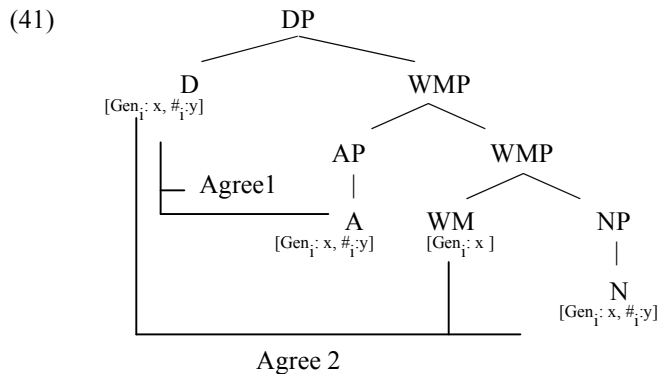

Since A, WM and N are all dominated by a projection of D and hence by the probing gender and number features of D, the Agree-relations involved in licensing the adjectival agreement on attributive adjectives in Romance all comply with the dominance requirement. Hence, adjectival agreement in Romance ceases to be a problem for the dominance requirement.

#### 4. Conclusion: the structural condition on Agree is the dominance condition

In this chapter, I took a closer look at the two empirical problems for the dominance requirement that I pointed out in chapter 3. The first problem concerned Swedish attributive adjectives in indefinite DPs. These adjectives display agreement just like their predicative counterparts. The second problem involved attributive adjectives in the Romance languages. These adjectives also display agreement. These two facts seemed to be problematic for the dominance requirement, because they involve attributive adjectives displaying agreement with N. The dominance requirement however predicts that it is impossible to establish an Agree relation between the adjective and noun. Despite these two problems, I nevertheless adopted the dominance requirement in chapter 3. The reason for this was that the dominance requirement is theoretically simpler than other alternatives that also suffer from empirical problems.

In this chapter, I have shown that the two empirical problems for the dominance requirement do not exist upon closer inspection. The reason for this is that agreement in the two problematic cases is not the result of a direct Agree relation between the adjective and the noun under my analysis of the strong-weak distinction and my account of the absence of weak adjectival inflection in Romance. Instead, this agreement is indirectly licensed with the help of a third element as the result of Indirect Agree.

In the case of agreement on Swedish indefinite DPs, this third element is the case assigner of the indefinite DP. In Swedish indefinite DPs, agreement on attributive adjectives is licensed because the case assigner first enters into an Agree relation with A and then with N. This results in feature sharing between A and N without A establishing an Agree relation with N. This sharing is then spelled out as agreement on N. Since the Agree relations established by the case assigner observe the dominance requirement, agreement on the adjective is licensed without violating the dominance requirement.

In the case of Romance, the element that licenses the adjectival agreement is D. Romance DPs differ from their Germanic counterparts with respect to the presence of WM, a functional head dedicated to word markers. The presence of this head licenses adjunction of the adjective to a level below the DP level. Because of this low adjunction, the Romance D first enters into an Agree relation with A and then with N. Like in Swedish indefinite DPs, this results in feature sharing between A and N. This is then spelled out as agreement on the adjective. Crucially, both instances of Agree that are involved in the licensing of this agreement observe the dominance requirement. Hence, Romance adjectival agreement is no longer a problem for the dominance requirement. In addition, the presence of WM and the low adjunction of the adjective caused by it, also explains why Romance does not have a strong-weak distinction. The low adjunction of the adjective ensures that D in Romance is not deactivated when it is in a configuration to enter into an Agree relation with N, unlike its counterpart in the Germanic languages. D therefore always licenses full adjectival agreement in the Romance languages, contrary to what happens in the Germanic languages. In this manner, the correlation between the presence of word markers and the absence of a strong-weak distinction on the adjectival inflection receives an explanation.

In this chapter, I have shown that agreement in the two problematic cases is thus licensed in compliance with the dominance requirement. As a consequence, these cases cease to be problematic. Hence, the dominance requirement is not only the theoretically simplest candidate for the structural condition on Agree. It is also the candidate that is the most empirically adequate one, since it does no longer face any empirical objections. I therefore conclude that the structural condition on Agree is the dominance requirement.



## Chapter 7

### Conclusion

In this thesis, I gave a unified account of the Germanic and Romance patterns of agreement on attributive adjectives. The main claim of the thesis is that agreement on attributive adjectives is licensed as a result of an Indirect Agree relation between the adjective and the noun, instead of being the result of a direct Agree relation. This Indirect Agree relation is established by a Probe (the case-assigner or D) that enters separately into an Agree relation with both the adjective and the noun. This results in feature sharing between the adjective and the noun without a direct Agree relation. In the Germanic languages, this Indirect Agree relation is blocked in case D is deactivated as a Probe. This yields the weak adjectival inflection. In case D is not a deactivated Probe, Indirect Agree licenses full agreement with the noun in Germanic, resulting in strong adjectival inflection. In Romance, Indirect Agree is never blocked. This is due to the fact that the presence of word markers in Romance licenses the adjunction of attributive adjectives at a level below D. As a result, D always licenses Indirect Agree between the adjective and the noun in Romance.

In addition, I proposed an account for the patterns of definiteness marking in the Germanic languages. Germanic attributive adjectives trigger internal merge of D. This results in DPs containing adjectives having two D-copies. In the double definiteness languages, the suffixal character of the definite D causes both these two D-copies to be spelled out. In most other Germanic languages, spelling out both D-copies is blocked for independent morphological reasons.

This thesis also proposes a couple of theoretical innovations. First, I argued that Chomsky's (2000,2001) c-command requirement on Agree should be replaced by the dominance requirement in (1).

- (1)           DOMINANCE REQUIREMENT ON AGREE  
          The Probe must dominate the Goal

I have shown that the dominance requirement is not only theoretically simpler than Chomsky's c-command requirement, but is also empirically superior.

The second theoretical innovation concerned the syntactic representation of features. I argued that Chomsky's (2000, 2001) standard attribute-value structure poses serious learnability issues for the L1 learner, while an alternative feature representation in which one of the feature interpretations is obligatory mapped onto an attribute without a value also faced problems. In order to resolve these problems, I proposed that the syntactic representation of morphosyntactic features depends on their morphological realization, in the way specified in (2).

## (2) MORPHO-DRIVEN FEATURE REPRESENTATION

If an interpretation of a particular feature is:

- a. **morphologically realized**, the interpretation is mapped onto a fully specified feature representation, i.e. an attribute-value pair.
- b. **morphologically unrealized**, the interpretation is mapped onto an underspecified feature representation, i.e. onto an attribute.

Under this proposal, the acquisition of the syntactic representation of morphosyntactic features can take place solely on the basis of positive evidence. In addition, morpho-driven feature representation predicts that there is crosslinguistic variation concerning the syntactic representation of morphosyntactic features. I showed that this crosslinguistic variation explains a difference between German and Swedish concerning the distinctions marked by the weak adjectival inflection.

Although I have discussed in detail agreement on Germanic attributive adjective, I only occasionally touched upon agreement of predicative adjectives. In chapter 3, I argued that the dominance requirement predicts that predicative adjectives agree with their subject. As I have shown in chapter 3, this prediction is borne out for Swedish. However, predicative adjectives do not display agreement in all Germanic languages. In German, Dutch and Yiddish, predicative adjectives do not agree (Vikner (2006)). This is illustrated in (3) for German. In (3), the gender of the subject varies, but the form of the predicative adjective does not change.

- (3) a. *Der*                      *Mann*    *ist*    *alt.*                      [German]  
          the.NOM.MASC.SG    man    is    old  
          ‘the man is old’
- b. *Die*                      *Frau*    *ist*    *alt.*  
          the.NOM.FEM.SG    woman is    old  
          ‘the woman is old’
- c. *Das*                      *Haus*    *ist*    *alt.*  
          the.NOM.NEUT.SG    house is    old  
          ‘the house is old’

I hope that future research will show that these facts can be incorporated in the present analysis of adjectival agreement. In addition, it will also be interesting to see whether my analysis can also account for patterns of adjectival agreement attested outside of the Germanic and Romance languages.

## References

- Abney, Steven Paul (1987). *The English noun phrase in its sentential aspect*. Phd dissertation, MIT, Cambridge, Mass. <http://www.vinartus.net/spa/87a.pdf>
- Aboh, Enoch (2004). 'Topic and focus within D', *Linguistics in the Netherlands* 21: 1-12.
- Adger, David (2007). A minimalist theory of feature structure. *LingBuzz*/000583.
- Allan, Robin, Philip Holmes, & Tom landskær-Nielsen (1995). *Danish: a comprehensive grammar*. Routledge, London
- Anderson, Stephen (1992). *Amorphous Morphology*. Cambridge University Press, Cambridge.
- Aoun, Joseph & Dominique Sportiche (1983). 'On the formal theory of government', *The Linguistic Review* 2 (3): 211-236.
- Barbiers, Sjef (2005). 'Variation in the morphosyntax of ONE', *Journal of Comparative Germanic Linguistics*, 8: 159-183.
- Baker, Mark (2008). *The syntax of agreement and concord*. Cambridge University Press, Cambridge, UK.
- Bayer, Josef, Markus Bader & Michael Meng (2001). 'Morphological underspecification meets oblique case: syntactic and processing effects in German', *Lingua* 111: 465-514.
- Béjar, Susanna (2000). 'Locality, cyclicity, and Georgian verbal morphology', ms. University of Toronto.
- Benveniste, Émile (1966). *Problèmes de linguistique générale*. Gallimard, Paris.
- Berit, Åsse & Rolf Strandskogen (1995). *Norwegian: an essential grammar*. Routledge, London.
- Bernstein, Judy B. (1991). 'DPs in French and Walloon: evidence for parametric variation in nominal head movement'. *Probus* 3: 1-26.
- Bernstein, Judy B. (1993). *Topics in the syntax of nominal structure across Romance*. Phd dissertation, City University of New York.
- Bernstein, Judy (1997). 'Demonstrative and reinforcers in Romance and Germanic languages.' *Lingua* 102: 87-113.
- Bernstein, Judy (2001). 'The DP-hypothesis. Identifying clausal properties in the nominal domain, in Mark Baltin & Chris Collins (eds.). *The handbook of contemporary syntactic theory*. Blackwell, Oxford.
- Bhatt, Rajesh (2005). 'Long distance agreement in Hindi-Urdu', *Natural Language and Linguistic Theory*, 23 (4): 757-807.
- Bianchi, Valentina (1999). *Consequences of antisymmetry: headed relative clauses*. Berlin, Mouton de Gruyter.
- Bobaljik, Jonathan David (2002). 'A-chains at the PF-interface: copies and 'covert movement'', *Natural Language & Linguistic Theory* 20: 197-267.
- Brody, Michael (1997). 'Perfect chains', in *Elements of grammar*, Liliane Haegeman (Ed.), 139-167. Kluwer Academic Publishers, Dordrecht.

- Cardinaletti, Anna (1998). 'On the deficient/strong opposition in possessive systems', in *Possessors, predicates and movement in the determiner phrase*, Artemis Alexiadou & Chris Wilder (eds.), p. 17-53. John Benjamins, Amsterdam.
- Chomsky, Noam (1955). *The logical structure of Linguistic Theory*, published 1979, University of Chicago Press.
- Chomsky, Noam (1986). *Barriers*. The MIT Press, Cambridge, Mass.
- Chomsky, Noam (1995). *The minimalist program*. The MIT Press, Cambridge Mass..
- Chomsky, Noam (2000). "Minimalist Inquiries: The Framework. *Step by Step: Essays in Minimalist Syntax in Honor of Howard Lasnik*, ed. by Robert Martin, David Michaels and Juan Uriagereka, 89-155. Cambridge, MA: The MIT Press.
- Chomsky, Noam (2001). 'Derivation by phase', in Michael Kenstowicz (eds.), *Ken Hale: a life in language*, p. 1-52. The MIT Press, Cambridge Mass..
- Chomsky, Noam (2005). 'On phases', ms. MIT, Cambridge Mass.
- Cinque, G. (1994). 'Evidence for Partial N-movement in the Romance DP,' *Italian Syntax and Universal Grammar*, CUP, Cambridge, 287-309.
- Collins, Chris (2002). 'Eliminating labels', Samuel D. Epstein & T. Daniel Seely (eds.), *Derivation and explanation in the minimalist program*, 42-64. Blackwell publishers, Oxford.
- Cowper, Elizabeth (2005). 'A note on number', *Linguistic Inquiry* 36 (3): 441-455.
- Delsing, Lars-olof (1988). 'The Scandinavian Noun Phrase', *Working Papers in Scandinavian Syntax* 42: 57-79.
- Delsing, Lars-olof (1993). *The internal structure of Noun Phrases in the Scandinavian languages: a comparative study*. Department of Scandinavian Languages. University of Lund.
- Delsing, Lars-Olof (1998). 'Possession in Germanic', in *Possessors, predicates and movement in the determiner phrase*, Artemis Alexiadou & Chris Wilder (eds.), p. 87-108. John Benjamins, Amsterdam.
- Donaldson, Bruce C. (1993). *A grammar of Afrikaans*. Mouton de Gruyter, Berlin.
- Drosdowski, Günther (1984). *Duden. Grammatik der deutschen Gegenwartssprache*. Duden Band 4. Dudenverlag, 4<sup>th</sup> edition, Mannheim.
- Einarsson, Stefán (1945). *Icelandic: grammar, texts, glossary*. The John Hopkins Press Baltimore.
- Embick, David & Alec Marantz (2008). 'Architecture and blocking'. *Linguistic Inquiry* 39 (1): 1-53.
- Embick, David & Rolf Noyer (2001). 'Movement operations after syntax', *Linguistic Inquiry* 32: 185-230.
- Epstein, Samuel David (1999). 'Un-principled syntax and the derivation of syntactic relations'. *Working Minimalism*, ed. by Samuel David Epstein & Norbert Hornstein, 317-345. The MIT Press, Cambridge, MA.
- Etxepare, Ricardo (2005). 'Number long distance agreement in (substandard) Basque', *International Journal of Basque Linguistics and Philology (ASJU) special volume in honor of Larry Trask*: 303-350.
- Frampton, John & Sam Gutmann (2000). 'Agreement is feature sharing', Ms. Northeastern University.

- Frampton, John & Sam Gutmann (2006). 'How sentences grow in the mind', in Cedric Boeckx (eds.), *Agreement Systems*, p. 121-157. John Benjamins, Amsterdam.
- Frank, Robert & K.Vijay-Shanker (2001). 'Primitive c-command', *Syntax* 4: 164-204.
- Frank, Robert, Paul Hagstrom & K.Vijay-Shanker (2002). 'Roots, constituents and c-command', in *Theoretical approaches to universals*, Artemis Alexidou (ed.), 109-137. John Benjamins, Amsterdam.
- Frege, Gottlob (1892). 'Über Sinn und Bedeutung', *Zeitschrift für Philosophie und philosophische Kritik C*: 25-50.
- Giusti, Giuliana (1994). 'Enclitic articles and double definiteness: a comparative analysis of nominal structure in Romance and Germanic', *The linguistic review* 11: 241-255.
- Grimm, Jacob (1870). *Deutsche Grammatik, Band I*. Berlin.
- Haegeman, Liliane (2000). 'Genus en naamwoordverplaatsing het Westvlaams', *Taal en Tongval* 52: 115-135.
- Haegeman, Liliane & Terje Lohndal (to appear). 'Negative concord and (multiple) Agree: a case study from West Flemish', to appear in *Linguistic Inquiry*.
- Haegeman, Liliane & Marleen van Peteghem (2002). 'Le genre grammatical dans quelques dialectes flamands', in Philip Hiligsmann (ed.), *Le néerlandais en France et en Belgique francophone: approches scientifiques/ Het Nederlands in Frankrijk en in Franstalig België wetenschappelijk en didactisch benaderd*, 77-90. Éditions du conseil scientifique de l'université Charles de Gaulle, Lille 3, Lille.
- Halle, Morris & Alec Marantz (1993). 'Distributed Morphology and the pieces of inflection', in Kenneth Hale & Samuel Jay Keyser (eds.), *The view from building 20*, p. 111-176. The MIT Press, Cambridge, Mass.
- Halle, Moris (1997). 'Distributed Morphology: impoverishment and fission', in *Papers at the interface*, MIT Working Papers in linguistics 30, Benjamin Bruening, Yoonjung Kang, and Martha Mc Ginnis (eds.), 425-449. MIT, Cambridge, Mass.
- Hankamer, Jorge & Line Mikkelsen (2002). 'A morphological analysis of definite nouns in Danish'. *Journal of Germanic Linguistics* 14 (2): 137-157.
- Hankamer, Jorge & Line Mikkelsen (2005). 'When movement must be blocked: a reply to Embick & Noyer', *Linguistic Inquiry* 36: 85-125.
- Harley, Heidi & Rolf Noyer (2003). Distributed Morphology, in Lisa Cheng & Rint Sybesma (eds.), *The second glot internationall state-of-the-article book*, p. 463-496. Mouton de Gruyter, Berlin.
- Harley, Heidi & Elizabeth Ritter (2002a). 'Person and number in pronouns: a feature-geometric account', *Language* 78: 482-526.
- Harley, Heidi & Elizabeth Ritter (2002b). 'Structuring the bundle: a universal morphosyntactic feature geometry', in *Pronouns: grammar and representation*, Horst J. Simon & Heike Wiese (eds.), 23-39. Amsterdam, John Benjamins.
- Harris, James W. (1985). 'Spanish word markers', in F.H. Nuessel Jr. (ed.), *Current issues in Spanish phonology and morphology*, 34-54. Indiana University Linguistics Club, Bloomington.



- Harris, James W. (1991). 'The exponence of gender in Spanish', *Linguistic Inquiry* 22 (1): 27-62.
- Haspelmath, Martin (1999). 'Explaining article-possessor incompatibility: economic motivations in Noun Phrase syntax', *Language* 75 (2): 247-269.
- Heck, Fabian; Gereon Müller & Jochen Trommer (2007). 'A phase-based approach to Scandinavian definiteness marking'. Ms. University of Leipzig. [to appear in the Proceedings of *WCCFL 26*.]
- Heck, Fabian & Malte Zimmermann (2004). 'Phasenentwicklung in der Entwicklungsphase: Randphänome der DP', talk given at the GCS, 21st of March 2004, Mannheim
- Heim, Irene & Angelika Kratzer (1998). *Semantics in Generative Grammar*. Blackwell Publishing, Oxford.
- Higginbotham, James (1985). 'A note on phrase-markers', *MIT Working Papers in Linguistics 6: papers in theoretical and applied linguistics*, Diana Archangeli, Andrew Bears & Richard Sproat (eds.), 87-100. Reprinted from *Revue Québécoise de linguistique* 13 (1): 147-166, 1983.
- Holmberg, Anders (1993). 'On the structure of predicate NP', *Studia Linguistica* 47: 126-138.
- Holmes, Philip & Ian Hincliffe (1994). *Swedish: a comprehensive grammar*. London: Routledge.
- Hornstein, Norbert & Jairo Nunes (2008). 'Adjunction, labeling, and Bare Phrase Structure', *Biolinguistics* 2 (1): 57-86. <http://www.biolinguistics.eu>
- Jakobson, Roman (1936). *Beitrag zur Allgemeine Kasuslehre: Gesamtbedeutungen der russischen Kasus*, in *Selected writings II: Words and Language*, Roman Jakobson, 23-71 (1971). Mouton, The Hague.
- Julien, Marit (2002). 'Determiners and word order in Scandinavian DPs', *Studia Linguistica* 56: 264-314.
- Julien, Marit (2003). 'Double definiteness in Scandinavian', *Nordlyd* 31 (1): 230-244.
- Julien, Marit (2005). *Nominal Phrases from a Scandinavian Perspective*. John Benjamins, Amsterdam.
- Kayne, Richard S. (1994). *The anti-symmetry of syntax*. The MIT Press, Cambridge, Mass.
- Koppen, Marjo van (2005). 'One Probe, Two Goals: aspects of agreement in Dutch dialects', doctoral dissertation, Leiden University.
- Kerster, Ellen Petra (1993). 'The inflection properties of Scandinavian adjectives', *Studia Linguistica* 47 (2): 139-153.
- Kester, Ellen-Petra (1996). *The nature of adjectival inflection*. Doctoral dissertation, Utrecht University.
- Kiparsky, Paul (1973). "Elsewhere in phonology", in *Festschrift for Morris Halle*, Paul Kiparsky and Stephen Anderson (eds.). Holt, Rinehart and Winston, New York
- Leu, Thomas (2008). *The internal syntax of determiners*. Doctoral dissertation, New York University.
- Longobardi, Giuseppe (1994). 'Reference and proper names: a theory of N-movement in syntax and Logical Form', *Linguistic Inquiry* 25 (4): 609-665.

- Longobardi, Giuseppe (2001). 'How comparative is semantics? A unified parametric theory of bare nouns and proper names', *Natural Language Semantics* 9: 335-369.
- Longobardi, Giuseppe (2005). 'Toward a unified grammar of Reference', *Zeitschrift für Sprachwissenschaft* 24: 5-44.
- Longobardi, Giuseppe (2006). 'Reference to individuals, person, and the variety of mapping parameters. Ms. Università di Trieste (to appear in *Proceedings of the Copenhagen Symposium on Determination*, A. Klinge & H. Müller (eds.))
- Matushansky, Ora (2005). 'Going through a phase', in Martha Mc. Ginnis & Norvin Richards (eds.), *Perspectives on Phases*, 157-181. MIT Working Papers in Linguistics 49. MIT, Cambridge, Mass.
- McCawley, James (1968). 'Concerning the base component of a transformational grammar', *Foundations of language* 4: 243-269.
- McCloskey, James (2000). 'Quantifier float and wh-movement in Irish English', *Linguistic Inquiry* 31 (1): 57-84.
- Müller, Gereon (2004). 'Remarks on nominal inflection', in Ingrid Kaufmann & Barbara Stiebels (eds.), *More than words: a festschrift for Dieter Wunderlich*, 113-145. Akademie Verlag, Berlin.
- Nunes, Jairo (2001). 'Sideward movement', *Linguistic Inquiry* 32 (2): 303-344.
- Perlmutter, David M. (1970). 'On the article in English', in *Progress in linguistics*, Manfred Bierwisch, and Karl E. Heidolph, (eds.), 233-248. Mouton, The Hague.
- Pesetsky, David (1989). 'Language particular processes and the earliness principal', ms. MIT.
- Pesetsky, David (1998). 'Some optimality principles of sentence pronunciation, in *Is the best good enough?*, Pilar Barbosa, Danny Fox, Paul Hagstrom, Martha McGinnis, and David Pesetsky, 337-384. The MIT Press, Cambridge, Mass..
- Pesetsky, David & Esther Torrego (2001). 'T-to-C, causes and consequences', M. Kenstowicz (ed.), *Ken Hale: a life in language*, 355-426. The MIT Press, Cambridge, Mass.
- Pesetsky, David & Torrego, Esther (2004). 'The syntax of valuation and the interpretability of features', ms. MIT/Umass. Published in 2007, in *Phrasal and clausal architecture: syntactic derivation and interpretation*, Simin Karimi, Vida Samilan and Wendy K. Wilkins, 262-294. John Benjamins, Amsterdam.
- Picallo, Carme, (2005). 'Some notes on grammatical gender and l-pronouns', *Fachbereich Sprachwissenschaft, Arbeitspapier* 119: 107-121. Universität Konstanz, Germany.
- Pollard, Carl & Ivan A. Sag (1994). *Head-driven phrase structure grammar*. CSLI/University of Chicago Press, Chicago.
- Poser, William J. (1992). 'Blocking of phrasal constructions by lexical items', in *Lexical matters*, Ivan A. Sag & Anna Szabolcsi (eds.), p. 111-130. CSL, Stanford, CA.
- Potsdam, Eric & Maria Polinsky (2001). 'Long distance Agree and topic in Tsez', *Natural Language and Linguistic Theory* 19 (3): 583-646.

- Preminger, Olger (2008). 'No phi, no problem', ms. MIT, December 2008 version, <http://web.mit.edu/omerp/www/files/Preminger---No-Phi,-No-Problem.pdf>.
- Rezac, Milan (2003). 'The fine structure of cyclic Agree', *Syntax* 6 (2): 156-182.
- Rezac, Milan (2004). *Elements of cyclic syntax: Agree and Merge*, doctoral dissertation, University of Toronto.
- Richards, Norvin (1997). *What moves where when in which language*, PhD-thesis, MIT, Cambridge Mass.
- Ritter, Elizabeth (1992). 'Cross-linguistic evidence for number phrase'. *Canadian Journal of Linguistics* 37: 197-218.
- Roehrs, Dorian (2006). *The Morpho-syntax of the Germanic Noun Phrase: determiners move into the determiner phrase*. Doctoral dissertation, Indiana University, Bloomington.
- Roehrs, Dorian (2009). *Demonstratives and definite articles as nominal auxiliaries*. John Benjamins, Amsterdam.
- Rooryck, Johan (1994). 'On two types of underspecification: towards a feature theory shared by syntax and phonology', *Probus* 6, 207-233
- Russell, Bertrand (1905). 'On denoting', *Mind* 14: 479-493.
- Santelmann, Lynn (1993). 'The distribution of double determiners in Swedish: *den* support in D<sup>o</sup>', *Studia Linguistica* 47 (2): 154-176.
- Sauerland, Uli (1996). 'The late insertion of Germanic inflection', ms. MIT
- Schane, S. (1968). *French phonology and morphology*. The MIT Press, Cambridge, Mass.
- Schlenker, Phillipe (1999). 'La Flexion de l'adjectif en allemand: la morphologie de haut en bas', *Recherches linguistiques de Vincennes* 28: 115-132.
- Schoorlemmer, Maaïke (1998). 'Possessors, Articles and Definiteness', in *Possessors, predicates and movement in the determiner phrase*, Artemis Alexiadou & Chris Wilder (eds.), p. 55-86. John Benjamins, Amsterdam.
- Sigurðsson, Halldór Ármann (1993). 'The structure of the Icelandic NP', *Studia Linguistica* 47: 177-197.
- Sigurðsson, Halldór Ármann (2006). 'The Icelandic Noun Phrase: central traits', *Arkiv för nordisk filologi* 121: 193-236.
- Speas, Margaret J. (1990). *Phrase structure in natural language*. Kluwer Academic Publishers, Dordrecht.
- Stepanov, Arthur (2001). 'Late adjunction and minimalist phrase structure', *Syntax* 4 (2): 94-125.
- Sternefeld, Wolfgang (2004). 'Feature checking, case, and agreement in German DPs' in Gereon Müller, Lutz Gunkel & Gisela Zifonun (eds.), *Explorations in Nominal Inflection*, p. 269-299. Mouton de Gruyter, Berlin.
- Svenonius, Peter (1993). 'Selection, adjunction, and concord in the DP. *Studia Linguistica* 47 (2): 198-220.
- Svenonius, Peter (1994). 'The structural location of the attributive adjective'. *Proceedings of the 12<sup>th</sup> West Coast Conference on Formal Linguistics*, ed. by E. Ducan, D. Farkas & P. Spaelti, pp. 439-454. CSLI, Stanford CA.
- Taraldsen, Knut Tarald (1990). 'D-projections and N-projection in Norwegian', in *Grammar in Progress: Glow essays for Henk van Riemsdijk*, Joan Mascaro and Marina Nesper (eds.), p. 419-431. Foris Publications, Dordrecht.

- Taraldsen, Knut Tarald (1991). 'Two arguments for functional heads', *Lingua* 84 (2/3): 85-108.
- Vangsnes, Øystein (1999). *The identification of functional architecture*. Doctoral Dissertation, University of Bergen.  
<http://www.hf.uib.no/i/LiLi/SLF/ans/Vangsnes/Contents.html>
- Vikner, Sten (2006). SOV/SVO and predicative adjective agreement. Handout Dfgs and Glow summer school 2006. University of Stuttgart.
- Vogel, Ralf & Markus Steinbach (1995). On the (absence of a) base position for dative objects in German. *FAS papers in linguistics* 4: 99-131.
- Ward, Gregory & Betty Birner (1995). 'Definiteness and the English existential', *Language* 71 (4): 722-742.



## Samenvatting in het Nederlands

Congruentie is het verschijnsel in natuurlijke taal dat de vorm van het ene woord afhangt van de kenmerken van een ander woord. Zo hangt in het Nederlands de vorm van het attributieve bijvoeglijk naamwoord af van de geslachtskenmerken van het zelfstandig naamwoord. Attributieve bijvoeglijk naamwoorden als *mooi* eindigen met een *-e* als ze voor een enkelvoudig mannelijk of vrouwelijk zelfstandig naamwoord staan, als in (1a) en (1b). Indien het enkelvoudig zelfstandig naamwoord echter onzijdig is en wordt voorafgegaan door het onbepaald lidwoord *een*, dan krijgen attributieve bijvoeglijke naamwoorden geen uitgang, zoals in (1c).

- (1) a. *een mooie man*  
b. *een mooie vrouw*  
c. *een mooi huis*

Het attributieve bijvoeglijke naamwoord vertoont in het Nederlands dus congruentie met het zelfstandig naamwoord. In dit proefschrift wordt het verschijnsel congruentie nader onderzocht en in het bijzonder de congruentie tussen het bijvoeglijk naamwoord en het zelfstandig naamwoord, als in (1). Deze vorm van congruentie is in eerdere studies tamelijk onderbelicht gebleven. In dit proefschrift wordt deze vorm van congruentie in zowel de Germaanse als de Romaanse talen in detail onderzocht.

De Germaanse en Romaanse talen kennen een opmerkelijk verschil op het gebied van congruentie tussen bijvoeglijke en zelfstandige naamwoorden. In het merendeel van de Germaanse talen is congruentie op attributieve bijvoeglijke naamwoorden namelijk niet alleen gevoelig voor kenmerken van het zelfstandig naamwoord, zoals geïllustreerd in (1) hierboven, maar ook voor kenmerken van het lidwoord. Zo krijgt een bijvoeglijk naamwoord dat een onzijdig zelfstandig naamwoord modificeert, geen uitgang in het Nederlands als het lidwoord onbepaald is, als in (2a). Het krijgt echter de uitgang *-e* als het lidwoord bepaald is, zoals in (2b).

- (2) a. *een mooi huis*  
b. *het mooie huis*

Deze gevoeligheid van de congruentie op het bijvoeglijke naamwoord voor kenmerken van het lidwoord uit zich op een bijzondere manier, namelijk door de mate waarin de flexie op het bijvoeglijk naamwoord congruentie uitdrukt met het zelfstandig naamwoord. Over het algemeen kan worden gesteld dat als er geen lidwoord aanwezig is of het lidwoord onbepaald is, de flexie op het bijvoeglijk naamwoord volledige congruentie met het zelfstandig naamwoord uitdrukt. Bijvoorbeeld, in het Nederlands wordt in dat geval door middel van het onderscheid

tussen de *-e* uitgang en de afwezigheid van een uitgang congruentie op het bijvoeglijk naamwoord in getal en geslacht uitgedrukt met het zelfstandig naamwoord. Als het lidwoord echter bepaald is, dan drukt de flexie op het bijvoeglijk naamwoord geen of slechts gedeeltelijke congruentie uit met het zelfstandig naamwoord. In het Nederlands krijgen bijvoeglijke naamwoorden na een bepaald lidwoord bijvoorbeeld altijd de *-e* uitgang. Vanwege de gehele of gedeeltelijke afwezigheid van congruentie op het bijvoeglijk naamwoord na een bepaald lidwoord wordt de flexie op het bijvoeglijk naamwoord in zulke gevallen ook wel zwak genoemd. Zijn tegenhanger na onbepaalde lidwoorden staat bekend staat als sterk omdat deze wel congruentie uitdrukt (zie o.a. Grimm 1870).

In tegenstelling tot het Germaans, is de congruentie op het bijvoeglijk naamwoord in de Romaanse talen niet afhankelijk van kenmerken van het lidwoord. Zo is het Franse bijvoeglijk naamwoord *beau* ‘mooi’ wel afhankelijk van de geslachts- en getalskenmerken van het zelfstandig naamwoord (zie het verschil in vorm van het bijvoeglijk naamwoord tussen (3a/b) en (3c/d)), maar niet van de bepaaldheid van het lidwoord (vergelijk (3a) met (3b) en (3c) met (3d)).

- |     |    |                                                 |    |                                              |
|-----|----|-------------------------------------------------|----|----------------------------------------------|
| (3) | a. | <i>un beau bâtiment</i><br>een mooi gebouw.MNL  | c. | <i>une belle maison</i><br>een mooi huis.VRL |
|     | b. | <i>le beau bâtiment</i><br>het mooie gebouw.MNL | d. | <i>la belle maison</i><br>het mooie huis.VRL |

In dit proefschrift wordt een theoretisch model van het verschijnsel congruentie geïntroduceerd dat samen met een analyse van de Germaanse en Romaanse DP een elegante verklaring geeft voor deze congruentieverschijnselen.

Naast het verklaren van bovengenoemde congruentieverschijnselen heeft dit proefschrift ook een meer theoretisch gericht doel, namelijk het bijdragen aan de theorievorming over congruentie. De belangrijkste bijdrage van dit proefschrift op dit gebied betreft de syntactische configuratie waarin congruentie kan plaatsvinden. Dit proefschrift beargumenteert dat deze configuratie gedefinieerd moet worden in termen van de syntactische relatie dominantie in plaats van de standaard aangenomen (Chomsky 2000) c-commandeer relatie. Een definitie in termen van dominantie heeft zowel het voordeel dat het theoretisch simpeler is dan, als wel empirisch superieur is aan de standaardformulering in termen van c-commanderen.

Congruentie is gevoelig voor syntactische structuur. Voordat de congruentie op attributieve bijvoeglijke naamwoorden kan worden verklaard, moet daarom eerst de syntactische structuur waarin bijvoeglijke naamwoorden voorkomen bepaald worden. Voor de Germaanse attributieve bijvoeglijke naamwoorden gebeurt dit in hoofdstuk 2. In dit hoofdstuk wordt een analyse van de Germaanse DP gepresenteerd. Het uitgangspunt van het hoofdstuk wordt gevormd door DPs met bepaalde lidwoorden in het Zweeds, het Noors en het Faeröers. Deze DPs kennen een verdubbeling van het bepaald lidwoord als het zelfstandig naamwoord gemodificeerd wordt door een bijvoeglijk naamwoord. Is hier geen sprake van, dan treedt geen verdubbeling op. Dit wordt geïllustreerd in (4) voor het Zweeds. In (4a) waarin geen bijvoeglijk naamwoord aanwezig is, is het bepaald lidwoord een suffix op het zelfstandig naamwoord. In (4b) wordt het zelfstandig naamwoord gemodificeerd door een bijvoeglijk naamwoord en zijn er twee bepaalde

lidwoorden: hetzelfde nominale suffix als in (4a) en een vrijstaand bepaald lidwoord dat voorafgaat aan het bijvoeglijk naamwoord.

- |     |    |                                         |    |                                                                   |
|-----|----|-----------------------------------------|----|-------------------------------------------------------------------|
| (4) | a. | <i>hus-et</i><br>huis-het<br>'het huis' | b. | <i>det stora hus-et</i><br>het grote huis-het<br>'het grote huis' |
|-----|----|-----------------------------------------|----|-------------------------------------------------------------------|

In hoofdstuk 2 wordt de verdubbeling van het bepaald lidwoord in (4b) toegedicht aan een verplaatsing van D die wordt veroorzaakt door de aanwezigheid van het bijvoeglijke naamwoord. Deze verplaatsing creëert twee kopieën van D in de syntaxis. In de postsyntactische morfologische component (cf. Halle en Marantz 1993) worden beide kopieën gerealiseerd vanwege de suffixachtige eigenschappen van het bepaald lidwoord.

In tegenstelling tot het Zweeds, Noors en Faeröers, kennen de andere Germaanse talen geen verdubbeling van het bepaald lidwoord. Dit heeft echter geen syntactische oorzaak, maar een morfologische. Indien er een bijvoeglijk naamwoord aanwezig is in de DP, vindt er in de syntaxis in alle Germaanse talen verplaatsing plaats van D. De twee kopieën van D die dit oplevert, worden echter door de morfologie om uiteenlopende redenen in Germaanse talen anders dan het Zweeds, Noorse en Faeröers niet gerealiseerd. In het Nederlands en het Duits, is het bepaald lidwoord bijvoorbeeld een vrij morfeem. Dit zorgt ervoor dat er in die talen één van kopieën van D morfologisch niet wordt gerealiseerd. De syntactische structuur van de DP is dus gelijk in de Germaanse talen, een klein verschil in het IJslands daargelaten, maar de morfologie van de DP kan verschillen. Deze uniforme syntactische structuur van de Germaanse DP vormt de basis voor de analyse van de congruentie op het bijvoeglijk naamwoord in de Germaanse talen in de hoofdstukken 4 en 5.

Voordat de congruentie op het bijvoeglijk naamwoord aan bod komt, wordt in hoofdstuk 3 eerst de syntactisch-structurele conditie op congruentie bestudeerd. Zoals hierboven reeds opgemerkt is congruentie gevoelig voor syntactische structuur. Een bepaald element kan alleen met een ander element congrueren indien de twee elementen zich in een bepaalde syntactische configuratie bevinden. In het minimalisme wordt standaard aangenomen dat deze configuratie in termen van c-commanderen moet worden gedefinieerd (Chomsky 2000) en dan wel zo dat het element dat de congruentie vertoont het element dat de congruent bepaalt moet c-commanderen. Een definitie in termen van c-commanderen is echter niet zonder problemen. C-commanderen is namelijk geen primitieve syntactische relatie omdat het gedefinieerd is met behulp van een andere syntactische relatie, te weten domineren. Indien een definitie die geformuleerd is in een primitievere syntactische relatie dan c-commanderen dezelfde feiten kan verklaren, dan heeft zo'n definitie de voorkeur boven de standaarddefinitie. In hoofdstuk 3 wordt een alternatieve definitie van de structurele conditie op congruentie voorgesteld, die geformuleerd is in een primitievere syntactische relatie dan c-commanderen. Deze alternatieve definitie is de conditie gegeven in (5).



- (5) DOMINANTIECONDITIE  
Om congruentie mogelijk te maken moet het element dat congruentie vertoont het element dat congruentie bepaalt domineren.

In combinatie met Bare Phrase Structure is de dominantieconditie in (5) niet alleen een theoretisch simpelere conditie dan de standaard c-commandeer conditie, maar verklaart het ook meer congruentie-verschijnselen, zoals in hoofdstuk 3 en een gedeelte van hoofdstuk 6 wordt beargumenteerd.

In het eerste gedeelte van hoofdstuk 4 wordt een aantal andere aspecten van congruentierelaties behandeld. De belangrijkste daarvan zijn de syntactische representatie van morfosyntactische kenmerken en de manier waarop congruentierelaties in de syntaxis gelegd worden. Er wordt beargumenteerd dat de manieren waarop morfosyntactische kenmerken standaard gerepresenteerd worden in het minimalistische programma leerbaarheidproblemen opleveren voor de L1 taalleerder. Om deze problemen te omzeilen wordt er een nieuwe syntactische representatie van morfosyntactische kenmerken geïntroduceerd. De essentie van dit voorstel is dat de representatie van een morfosyntactische kenmerk afhankelijk is van de morfologische realisatie van dat kenmerk. In het geval het kenmerk morfologisch gerealiseerd is, dan is de morfosyntactische representatie van het kenmerk volledig gespecificeerd. Is een morfosyntactisch kenmerk niet morfologisch gerealiseerd, dan is de morfosyntactische representatie van het desbetreffende kenmerk ondergespecificeerd. De specificatie of onderspecificatie van een morfosyntactisch kenmerk heeft gevolgen voor het aantal congruentierelaties dat in de syntaxis kan worden gelegd. Wat betreft de manier waarop congruentierelaties in de syntaxis gelegd worden, wordt het voorstel van Frampton & Gutmann (2000, 2006) en Pesetsky & Torrego (2004) aangenomen. Dat voorstel houdt in dat het leggen van congruentierelaties als resultaat heeft dat één kenmerk letterlijk gedeeld wordt tussen verschillende elementen. In combinatie met de dominantieconditie uit hoofdstuk 3 vormen de morfologisch gestuurde representatie van morfosyntactische kenmerken en de gedeelde-kenmerken-visie op het leggen van congruentierelaties de basis voor de analyse van congruentie op bijvoeglijke naamwoorden in de Germaanse talen.

Na het voorwerk gedaan in hoofdstuk 2, 3 en het eerste gedeelte van hoofdstuk 4, wordt in het tweede gedeelte van hoofdstuk 4 de analyse van de congruentie op het Germaanse attributieve bijvoeglijk naamwoord geïntroduceerd aan de hand van het Zweeds. Zoals hierboven besproken, kent het merendeel van de Germaanse talen het verschil tussen sterke en zwakke flexie op het bijvoeglijk naamwoord. Bijvoeglijke naamwoorden met sterke flexie vertonen volledige congruentie met het zelfstandig naamwoord. Bijvoeglijke naamwoorden met zwakke flexie vertonen geen of slechts gedeeltelijke congruentie met het naamwoord. Dit verschil wordt uitgelegd door de indirecte syntactische fiattering van de congruentie op het bijvoeglijk naamwoord. Deze indirecte fiattering is het gevolg van de dominantieconditie uit hoofdstuk 3. Onder deze conditie is het namelijk onmogelijk voor het bijvoeglijk naamwoord om een directe congruentierelatie met het zelfstandig naamwoord aan te gaan. In plaats daarvan wordt de congruentie op het bijvoeglijk naamwoord gefiatteerd door bemiddeling van een ander element.

In het geval van sterke inflectie is dit element de casustokenner van de desbetreffende DP. De casustokenner gaat eerst een congruentierelatie met het bijvoeglijk naamwoord aan. Omdat dit slechts leidt tot het delen van ondergespecificeerde kenmerken tussen het bijvoeglijk naamwoord en de casustokenner, leidt deze congruentierelatie niet tot een desactivatie van de casustokenner. De casustokenner gaat daarom verder op zoek naar gespecificeerde kenmerken. Die vindt de casustokenner op het zelfstandig naamwoord. De casustokenner gaat daarom een tweede congruentierelatie aan, dit keer met het zelfstandig naamwoord. Door de eerdere congruentierelatie heeft dit, onder de gedeelde-kenmerken-visie op contraentie, als resultaat dat het bijvoeglijk naamwoord wordt geassocieerd met de kenmerken van het zelfstandig naamwoord. Op deze wijze wordt de congruentie op het bijvoeglijk naamwoord syntactische gefiatteerd door bemiddeling van de casustokenner.

In DPs met een bepaald lidwoord is er in het Zweeds en in het Nederlands een gebrek aan congruentie tussen het bijvoeglijk naamwoord en het zelfstandig naamwoord. De oorzaak hiervan is te vinden in de syntactische derivatie van deze DPs. Deze is namelijk van dien aard dat het voor de casustokenner onmogelijk is om te bemiddelen tussen het bijvoeglijk naamwoord en het zelfstandig naamwoord wat betreft de congruentie. Dit komt door de verplaatsing van D over de positie van het bijvoeglijk naamwoord. Deze verplaatsing werd in hoofdstuk 2 geïntroduceerd om de verdubbeling van het bepaald lidwoord in het Zweeds, Noors en Faeröers te verklaren, maar werd vervolgens gegeneraliseerd naar alle Germaanse talen. Aangezien het bepaald lidwoord in het Zweeds en het Nederlands congruentie vertoont met het zelfstandig naamwoord, gaat D in DPs met een bepaald lidwoord een congruentierelatie aan met het zelfstandig naamwoord. Dit gebeurt al voordat D verplaatst wordt over het bijvoeglijk naamwoord heen. Na verplaatsing van D is de hogere kopie daarom reeds voorzien van de kenmerken van het zelfstandig naamwoord. Het gaat daarom geen congruentierelatie aan met het bijvoeglijk naamwoord en kan daarom niet bemiddelen tussen het bijvoeglijk naamwoord en het zelfstandig naamwoord. Ook voorkomt de hogere kopie van D dat de casustokenner kan bemiddelen tussen het bijvoeglijk naamwoord en het zelfstandig naamwoord. Op het moment dat de casustokenner op zoek gaat naar een element om een congruentierelatie mee aan te gaan vindt de casustokenner eerst de hogere kopie van de D. Omdat deze kopie, zoals hierboven uitgelegd, reeds geassocieerd is met de kenmerken van het zelfstandig naamwoord, gaat de casustokenner een congruentierelatie aan met deze kopie. Omdat de kenmerken waarmee de hogere D geassocieerd is volledig gespecificeerd zijn, deactiveert deze congruentierelatie de casustokenner. Als een gevolg hiervan gaat de casustokenner geen congruentierelatie meer aan met het bijvoeglijk naamwoord en kan daarom geen bemiddelende rol tussen het bijvoeglijk naamwoord en het zelfstandig naamwoord vervullen. Om deze reden participeert het bijvoeglijk naamwoord in geen enkele congruentierelatie. Dit wordt vervolgens uitgespeld op het bijvoeglijk naamwoord als zwakke inflectie.

In hoofdstuk 4 wordt uitgelegd hoe deze analyse van het onderscheid tussen sterke en zwakke flexie alle details van de congruentie op attributief gebruikte bijvoeglijke naamwoorden in het Zweeds, Noors, Deens en Nederlands verklaart. Hoofdstuk 5 gaat over sterke en zwakke flexie in het Duits. Wat betreft de flexie van

bijvoeglijke naamwoorden verschilt het Duits van de eerder genoemde Germaanse talen op twee verschillende manieren. Allereerst kent het Duits ook casuscongruentie op attributieve bijvoeglijke naamwoorden, terwijl dat de eerder genoemde Germaanse talen dat niet kennen. Als een gevolg hiervan kent het Duitse paradigma voor flexie op bijvoeglijke naamwoorden veel meer vormen. Ten tweede is in het Duits, anders dan in het Nederlands, Zweeds, Noors en Deens, de zwakke flexie van het bijvoeglijk naamwoord niet invariabel. De Duitse zwakke flexie drukt namelijk nog een casus- en getalsonderscheid uit, al is het aantal distincties dat door de zwakke flexie wordt uitgedrukt aanzienlijk lager dan in de sterke flexie. Deze twee verschillen vormen echter geen probleem voor de analyse van sterke en zwakke flexie van hoofdstuk 4.

Het casusonderscheid als wel als het getalsonderscheid in de Duitse zwakke flexie volgen uit de analyse indien men rekening houdt hoe naamval en getal op N gespecificeerd zijn op N aan het begin van de derivatie. Gezien de morfologisch gestuurde syntactische representatie van kenmerken, is in het Duits het enkelvoud syntactisch gerepresenteerd als een ondergespecificeerd getalskenmerk. Nadat D een congruentierelatie is aangegaan met een enkelvoudig zelfstandig naamwoord, is daarom D geassocieerd met een ondergespecificeerd getalskenmerk. Als gevolg hiervan blijft D actief zoeken naar getalskenmerken en gaat daarom in het geval van een enkelvoudig zelfstandig naamwoord na verplaatsing een congruentierelatie aan met het bijvoeglijk naamwoord. Deze relatie wordt vervolgens in het zwakke paradigma gerealiseerd als het getalsonderscheid. In het geval van naamval is iets soortgelijks aan de hand. Volgens Bayer, Bader en Meng (2001) is datief en genitief een gespecificeerd kenmerk in het nominale domein, maar worden nominatief en accusatief toegekend door een casustoekenner die zich buiten het nominale domein bevindt. Dit inzicht wordt in hoofdstuk 5 geïmplementeerd door datief en genitief een gespecificeerd kenmerk te laten zijn op N aan het begin van de derivatie en nominatief en accusatief een ondergespecificeerd casus kenmerk dat later door de casustoekenner wordt ingevuld. Hierdoor is de hogere D-kopie na verplaatsing wel actief voor casus in DPs met nominatief of accusatief als casus, maar niet in DPs met datief en genitief. In het eerste geval, gaat de hogere D-kopie een congruentierelatie aan met het bijvoeglijk naamwoord voor casus, net als voor getal bij enkelvoudige DPs. In het tweede geval, wordt er geen congruentierelatie voor casus aangegaan. Dit verschil wordt vervolgens in het zwakke paradigma uitgespeld als het casusverschil. Op deze manier is de analyse van hoofdstuk 4 flexibel genoeg om precies die distincties te voorspellen die er in de Duitse zwakke flexie voorkomen.

Zoals hierboven reeds opgemerkt kennen de Romaanse talen geen verschil tussen sterke en zwakke flexie op het attributief bijvoeglijk naamwoord. Hoofdstuk 6 geeft een verklaring waarom dit het geval is. Er is één Germaans dialect dat net als de Romaanse talen wel congruentie heeft op het attributief bijvoeglijk naamwoord, maar geen verschil heeft tussen sterke en zwakke flexie. Dit dialect is het West-Vlaams (Liliane Haegeman, persoonlijke correspondentie). Daarnaast deelt het West-Vlaams nog een eigenschap met de Romaanse talen in het nominale domein. Het heeft Word Markers op het zelfstandig naamwoord (Haegeman 2000, Haegeman & Van Peteghem 2002). Word Markers zijn morfemen waar de vorm in de meeste, maar niet alle, gevallen een relatie vertoont met het geslacht van het

zelfstandig naamwoord (Harris 1991; Bernstein 1993). In hoofdstuk 6 wordt beargumenteerd dat de aanwezigheid van Word Markers op een zelfstandig naamwoord er voor zorgt dat D pas na adjunctie van het bijvoeglijk naamwoord in de derivatie wordt ingevoegd. Als een gevolg hiervan is D in talen met Word Markers in staat om een congruentierelatie aan te gaan met het bijvoeglijk naamwoord voordat het een congruentierelatie aangaat met het zelfstandig naamwoord. Als een gevolg hiervan kan D in talen met Word Markers dezelfde bemiddelende rol vervullen als de casustoekenner in de gevallen van Germaanse sterke flexie. In andere woorden, D, anders dan in de Germaanse talen, fiatteert altijd een indirecte congruentierelatie tussen het bijvoeglijk naamwoord en het zelfstandig naamwoord in talen met een Word Marker op het zelfstandig naamwoord. Er is daarom geen sterk-zwak onderscheid op de adjectivale flexie in de Romaanse talen en het West-Vlaams.

In dit proefschrift maakt een combinatie van zoveel mogelijk expliciet gemaakte syntactische en morfologische theorie het mogelijk om in een verbazingwekkend detail de distincties die uitgedrukt worden door flexie op bijvoeglijke naamwoorden te voorspellen. Dit laat zien dat het combineren van syntactische en morfologische theorie een vruchtbare manier is om bepaalde fenomenen in natuurlijke taal te verklaren.



## **Curriculum Vitae**

Erik Schoorlemmer was born on 31 January 1980 in Haarlem, the Netherlands. After graduating from secondary school in 1998, he started studying French language and literature at Leiden University. In 2000, he also enrolled in the linguistics program at Leiden University. He received his master's degree in French language and literature in March 2004 (*cum laude*). In June 2004, he also completed his master's degree in General Linguistics (*cum laude*). From 2004 until 2009, he was a PhD-student at the Leiden University Center for Linguistics (LUCL). This thesis is the result of the research carried out during his years as a PhD-student at LUCL. He is currently employed as a lecturer in the French department at Leiden University.