



Universiteit  
Leiden  
The Netherlands

## **Pituitary hormone secretion in familial longevity : The Switchbox Study**

Jansen, Wilhelmina Maria

### **Citation**

Jansen, W. M. (2016, February 3). *Pituitary hormone secretion in familial longevity : The Switchbox Study*. Retrieved from <https://hdl.handle.net/1887/37577>

Version: Corrected Publisher's Version

License: [Licence agreement concerning inclusion of doctoral thesis in the Institutional Repository of the University of Leiden](#)

Downloaded from: <https://hdl.handle.net/1887/37577>

**Note:** To cite this publication please use the final published version (if applicable).

Cover Page



Universiteit Leiden



The handle <http://hdl.handle.net/1887/37577> holds various files of this Leiden University dissertation

**Author:** Jansen, Steffy

**Title:** Pituitary hormone secretion in familial longevity : The Switchbox Study

**Issue Date:** 2016-02-03

# CHAPTER 1

General introduction  
and outline of the thesis





## GENERAL INTRODUCTION

Advances in medicine have reduced infant mortality and cardiovascular deaths at middle age resulting in marked demographic changes. Consequently, worldwide, life expectancy and the proportion of elderly in the population are rising(1). Therefore, it is of critical importance to study genetic and environmental factors and biological mechanisms that allow people to remain healthy and active into their eighties, nineties and above and learn from them how to extend health span.

### Switchbox study

This thesis is part of the European project Switchbox, coordinated by Professor Barbara Demeneix from the Centre National de la Recherche Scientifique Paris, France, where six partners from five different countries hypothesized that health in old age is maintained by better homeostasis. As described in 1865 by the French physiologist Claude Bernard, homeostasis is the ability to dynamically adapt to environmental challenges so that internal conditions remain within certain limits and originates from the Greek words “ὅμοιος” meaning “similar” and “στάσις” meaning “standing still”(2).

### Brain-periphery communication

A good communication between brain and periphery is of critical importance to maintain homeostasis of vital parameters including body temperature, blood pressure, heart rate, and key metabolites, such as glucose. Homeostasis also includes the ability to dynamically adapt vital parameters according to changing internal needs such as those dictated by the sleep-wake rhythm and by changes in the environment, including perceived stress. Two main systems are important for maintenance of homeostasis 1) the nervous system which communicates in electric signals via neurons and 2) hormones which communicate in chemical signals. A master controller of these processes that plays a key role in homeostasis is the hypothalamus (Fig. 1). The hypothalamus receives signals from different brain regions and the periphery and translates these into neuronal and hormonal output signals and thus modulates many different physiological and behavioral processes. The hypothalamus plays an important role in the control of metabolism and of stress responses, two essential systems that are mostly affected during ageing(3). A key regulator of the maintenance of energy homeostasis is the hypothalamic-pituitary-thyroid (HPT)-axis while the stress response is regulated by the hypothalamic-pituitary-adrenal (HPA)-axis (Fig. 1).

Most studies in the field of geriatric medicine focus on diseased subjects or ageing subjects. Only a limited number of studies investigate subjects who have the propensity to reach old age in good health, to disentangle mechanisms that lead to healthy human longevity. Therefore, in this thesis we included offspring from long-lived

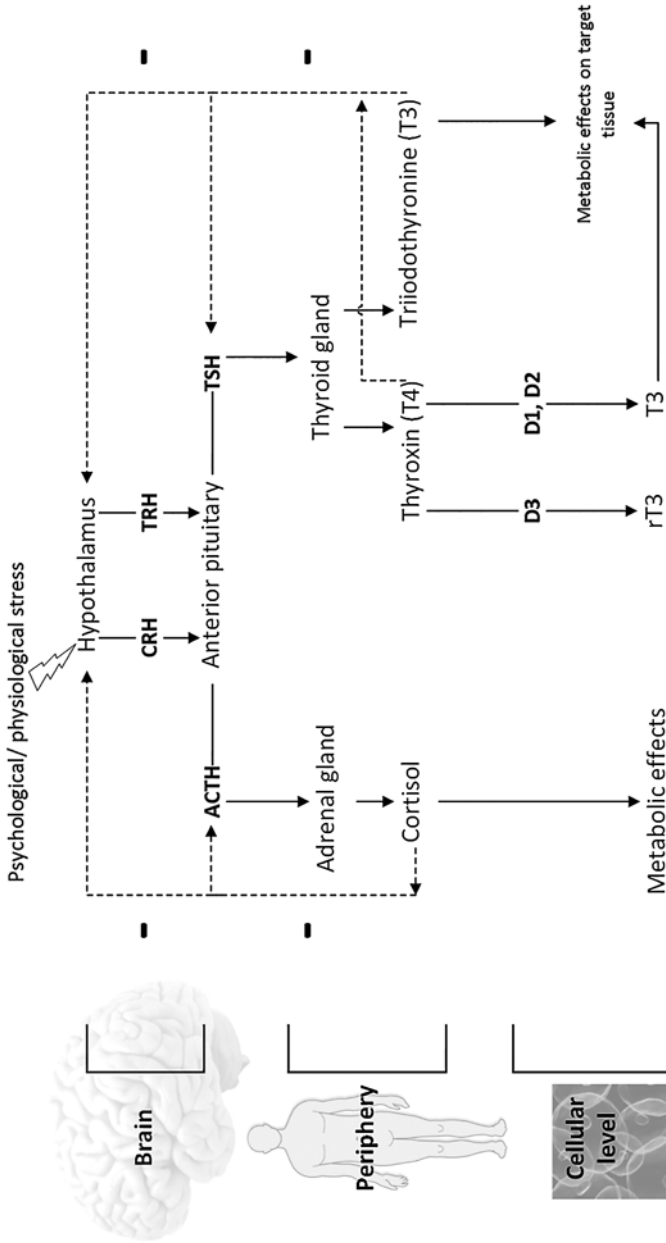

**Figure 1** 'Switchbox' overall hypothesis; the central role of the hypothalamus ('the Switchbox') in endocrine and metabolic homeostasis.

CRH: corticotropin-releasing hormone; TRH: thyrotropin-releasing hormone; ACTH: adrenocorticotropic hormone; TSH: thyroid stimulating hormone; D1,2,3: Deiodinase 1, Deiodinase 2, Deiodinase 3; rT3: reverse T3

siblings, who have the propensity to reach old age in good health together with partners thereof from the Leiden Longevity study (LLS)(4). The focus of this thesis will be on analysis of the HPT-axis and HPA-axis in participants who have the propensity to reach old age in good health compared to age-matched controls. In humans, we are able to assess the 'function' of the HPT- and HPA- axes by measuring the key hormones involved as well as physiological parameters that are affected by these systems (heart rate, metabolism) under different conditions.

### **Hormones and ageing**

The hypothalamic-pituitary-thyroid axis (HPT)-axis is of critical importance during the whole life cycle, and affects key processes, including tissue development, energy metabolism and homeostasis. There is inconsistency in the reporting of changes that occur during ageing in the HPT-axis. Most studies suggest increased levels of thyroid stimulating hormone (TSH)(3, 5-7), while others report no change(8) or lower levels of TSH(9) during ageing. Moreover, with ageing lower levels of fT3, but not fT4 were found(9). In elderly aged 85 years or over, high levels of thyroid stimulating hormone (TSH) have been associated with lower mortality(10), which was confirmed in the subgroup that survived to age ninety(3).

The hypothalamic-pituitary-adrenal (HPA)-axis is an important allostatic system and is of critical importance for survival(11, 12). Various strains of rodents, but not all, were found to exhibit elevated levels of ACTH and/or corticosterone during ageing under resting conditions(13). In humans, aged women tended to have increased morning acrophase under resting conditions(14). A dampened amplitude and an advanced timing of the circadian elevation was found in both men and women during ageing(14). As was found in different strains of aged rodents(13), aged humans may react stronger(15-18) and have a prolonged cortisol response after (psychological) stress(19, 20). This may be associated with impairments in physical and cognitive function, and with adverse metabolic features, such as visceral adiposity, insulin resistance, low high density lipoprotein levels, high blood pressure and increased triglyceride levels(12, 21), all characteristics of an ageing population.

### **Hormones and longevity**

In model organisms and animal models it was found that thyroid hormones (TH) may influence the rate of ageing(3). The maximum lifespan of small mammals such as mice, guinea pigs, Damara mole rats and naked mole rats are negatively correlated with levels of T4(22). Moreover, in different mice strains low T4 signaling in young adults and limited changes of T4 during lifespan were associated with extended life span in male mice(3). Other examples are the Ames dwarf mice, which have a mutation in the Pit-1 gene and the Snell dwarf mice, which have a mutation in the Prop-1 gene, both of which affect the development of the anterior pituitary. These

mice have a reduced activity of the somatotrophic-, lactotrophic- and thyroid-axes due to a combined lack of growth hormone (GH), thyroid stimulating hormone (TSH) and prolactin (PRL). Although these animals are small and have a reduced fertility, under laboratory condition these mice have an increased life span of at least 40% up to 70% compared to wild type mice(23). These endocrine deficits have also effects on their metabolism, resulting in lower core body temperature(24) and higher basal metabolic rate at standard animal room temperature due to the increased energy demands for thermoregulation(25). When Snell dwarf mice were treated for a long time with thyroxine (T4), which is also reduced in these animals, it reduces their life span, meaning that lifelong low thyroid hormone levels may contribute to the longevity phenotype in at least dwarf mice(26).

Also in humans, associations have been observed between thyroid hormone regulation and longevity. Families with the lowest mortality history score, displaying the lowest mortality, had the highest levels of TSH and lowest levels of free thyroxin (fT4) and free triiodothyronine (fT3)(27). In another cohort study, Ashkenazi Jewish centenarians also displayed higher TSH levels as did their offspring when compared to matched controls(28).

The HPA-axis is a critical component of the body's response to stressful conditions, including both physiological and psychological stressors. The many day to day responses to chronic and acute stress, including the 'fight or flight' reaction, result in cumulative load on the body's stress responsive physiological systems, such as the cardiovascular and glucose regulatory systems (allostatic load) which can have severe long term health consequences(12). Changes in HPA-axis are associated with different adverse conditions, including hypertension, impaired cognitive function and adverse metabolic features. In rats, genetic differences in HPA-axis activity and reactivity have been associated with differences in lifespan. Brown Norway rats which display distinct differences in HPA-axis activity and reactivity, including faster recovery after restraint stress, have extended lifespan(29), while Wistar Kyoto rats are characterized by shorter lifespan and hyper-reactivity to stressors(30). No human data was available on HPA-axis reactivity under resting conditions or stress conditions in relation with longevity.

The aim of this thesis was threefold. In the first part, we describe the Switchbox Leiden design and data collection, and method used for 24 hour blood sampling. In the second part, we characterized the HPT-axis, and in the third part the HPA-axis, in relation with familial longevity.



## OUTLINE OF THE THESIS

In **Part I: Switchbox Leiden: study design and data collection**, **chapter two** is an overview of the Switchbox study and the data collection procedure. In **chapter three** we customize 24 h blood sampling protocols for the application in aged study participants.

In **Part II: Hypothalamic-pituitary-thyroid axis and longevity**, we use in **chapter four** frequent blood sampling over 24 hours to study TSH secretion and TH levels. We investigate whether differences in TSH and/or TH concur with differences in energy metabolism. In **chapter five** we characterize the HPT-axis in more detail and investigate if changes in ultradian rhythmicity of TSH could be an underlying mechanism of the changes in HPT-axis function. Moreover, we investigate if changes in circadian rhythmicity of TSH contribute to the longevity phenotype.

In **Part III: Hypothalamic-pituitary-adrenal axis and longevity**, we collect in 330 offspring and partners from the LLS, saliva samples in a home based setting to study in **chapter six** if saliva cortisol levels in the morning and evening were different between offspring and partners. In **chapter seven** we investigate in 38 offspring and partners of the LLS the HPA-axis in more detail by analysis of the HPA-axis dynamics over a 24-hour period. And in **chapter eight** we challenge the HPA-axis to investigate if offspring compared to partners have a different physiological response to psychological stress.

In **chapter nine** we place our findings in perspective and discuss the importance of challenge experiments in physiological research and give indications for future research.

## REFERENCES

1. **Abbott A.** Ageing: growing old gracefully. *Nature*. 2004;428(6979):116-8.
2. **Cannon WB.** Physiological regulation of normal states: some tentative postulates concerning biological homeostatics". In A. Pettit(ed.). *A Charles Richet : ses amis, ses collègues, ses élèves* (in French). Paris: Les Éditions Médicales. 1926:p91.
3. **Bowers J, Terrien J, Clerget-Froidevaux MS, Gothie JD, Rozing MP, Westendorp RG, van Heemst D, and Demeneix BA.** Thyroid hormone signaling and homeostasis during aging. *Endocr Rev*. 2013;34(4):556-89.
4. **Westendorp RG, van Heemst D, Rozing MP, Frolich M, Mooijaart SP, Blauw GJ, Beekman M, Heijmans BT, de Craen AJ, Slagboom PE, and Leiden Longevity Study G.** Nonagenarian siblings and their offspring display lower risk of mortality and morbidity than sporadic nonagenarians: The Leiden Longevity Study. *J Am Geriatr Soc*. 2009;57(9):1634-7.
5. **Tunbridge WM, Evered DC, Hall R, Appleton D, Brewis M, Clark F, Evans JG, Young E, Bird T, and Smith PA.** The spectrum of thyroid disease in a community: the Whickham survey. *Clin Endocrinol (Oxf)*. 1977;7(6):481-93.
6. **Sawin CT, Chopra D, Azizi F, Mannix JE, and Bacharach P.** The aging thyroid. Increased prevalence of elevated serum thyrotropin levels in the elderly. *JAMA*. 1979;242(3):247-50.
7. **Hollowell JG, Staehling NW, Flanders WD, Hannon WH, Gunter EW, Spencer CA, and Braverman LE.** Serum TSH, T(4), and thyroid antibodies in the United States population (1988 to 1994): National Health and Nutrition Examination Survey (NHANES III). *J Clin Endocrinol Metab*. 2002;87(2):489-99.
8. **Barreca T, Franceschini R, Messina V, Bottaro L, and Rolandi E.** 24-hour thyroid-stimulating hormone secretory pattern in elderly men. *Gerontology*. 1985;31(2):119-23.
9. **van Coevorden A, Laurent E, Decoster C, Kerkhofs M, Neve P, van Cauter E, and Mockel J.** Decreased basal and stimulated thyrotropin secretion in healthy elderly men. *J Clin Endocrinol Metab*. 1989;69(1):177-85.
10. **Gussekloo J, van Exel E, de Craen AJ, Meinders AE, Frolich M, and Westendorp RG.** Thyroid status, disability and cognitive function, and survival in old age. *JAMA*. 2004;292(21):2591-9.
11. **Sapolsky RM, Krey LC, and McEwen BS.** The neuroendocrinology of stress and aging: the glucocorticoid cascade hypothesis. *Endocr Rev*. 1986;7(3):284-301.
12. **McEwen BS.** Protective and damaging effects of stress mediators. *N Engl J Med*. 1998;338(3):171-9.
13. **de Kloet ER.** Corticosteroids, stress, and aging. *Ann N Y Acad Sci*. 1992;663(357-71).
14. **Van Cauter E, Leproult R, and Kupfer DJ.** Effects of gender and age on the levels and circadian rhythmicity of plasma cortisol. *J Clin Endocrinol Metab*. 1996;81(7):2468-73.
15. **Otte C, Hart S, Neylan TC, Marmar CR, Yaffe K, and Mohr DC.** A meta-analysis of cortisol response to challenge in human aging: importance of gender. *Psychoneuroendocrinology*. 2005;30(1):80-91.
16. **Almela M, Hidalgo V, Villada C, van der Meij L, Espin L, Gomez-Amor J, and Salvador A.** Salivary alpha-amylase response to acute psychosocial stress: the impact of age. *Biol Psychol*. 2011;87(3):421-9.
17. **Kudielka BM, Buske-Kirschbaum A, Hellhammer DH, and Kirschbaum C.** HPA axis responses to laboratory psychosocial stress in healthy elderly adults, younger adults, and children: impact of age and gender. *Psychoneuroendocrinology*. 2004;29(1):83-98.
18. **Strahler J, Mueller A, Rosenloecher F, Kirschbaum C, and Rohleder N.** Salivary alpha-amylase stress reactivity across different age groups. *Psychophysiology*. 2010;47(3):587-95.
19. **Aguilera G.** HPA axis responsiveness to stress: implications for healthy aging. *Exp Gerontol*. 2011;46(2-3):90-5.
20. **Sapolsky RM, Krey LC, and McEwen BS.** The adrenocortical stress-response in the aged male rat: impairment of recovery from stress. *Exp Gerontol*. 1983;18(1):55-64.
21. **Seeman TE, Singer BH, Rowe JW, Horwitz RI, and McEwen BS.** Price of adaptation--allostatic load and its health consequences. MacArthur studies of successful aging. *Arch Intern Med*. 1997;157(19):2259-68.
22. **Buffenstein R, and Pinto M.** Endocrine function in naturally long-living small mammals. *Mol Cell Endocrinol*. 2009;299(1):101-11.

23. **Brown-Borg HM, Borg KE, Meliska CJ, and Bartke A.** Dwarf mice and the ageing process. *Nature*. 1996;384(6604):33.
24. **Hunter WS, Croson WB, Bartke A, Gentry MV, and Meliska CJ.** Low body temperature in long-lived Ames dwarf mice at rest and during stress. *Physiol Behav*. 1999;67(3):433-7.
25. **Bartke A, and Westbrook R.** Metabolic characteristics of long-lived mice. *Front Genet*. 2012;3(288).
26. **Vergara M, Smith-Wheelock M, Harper JM, Sigler R, and Miller RA.** Hormone-treated snell dwarf mice regain fertility but remain long lived and disease resistant. *J Gerontol A Biol Sci Med Sci*. 2004;59(12):1244-50.
27. **Roizing MP, Houwing-Duistermaat JJ, Slagboom PE, Beekman M, Frolich M, de Craen AJ, Westendorp RG, and van Heemst D.** Familial longevity is associated with decreased thyroid function. *J Clin Endocrinol Metab*. 2010;95(11):4979-84.
28. **Atzmon G, Barzilai N, Surks MI, and Gabriely I.** Genetic predisposition to elevated serum thyrotropin is associated with exceptional longevity. *J Clin Endocrinol Metab*. 2009;94(12):4768-75.
29. **Mos J, and Hollander CF.** Analysis of survival data on aging rat cohorts: pitfalls and some practical considerations. *Mech Ageing Dev*. 1987;38(1):89-105.
30. **Tizabi Y, Aguilera G, and Gilad GM.** Age-related reduction in pituitary corticotropin-releasing hormone receptors in two rat strains. *Neurobiol Aging*. 1992;13(2):227-30.

