



**Universiteit
Leiden**
The Netherlands

The circularity gap of nations: A multiregional analysis of waste generation, recovery, and stock depletion in 2011

Aguilar Hernandez, G.A.; Siguenza -Sanchez, C.P.; Donati, F.; Merciai, S.; Schmidt, J.; Dias Rodrigues, J.F.; Tukker, A.

Citation

Aguilar Hernandez, G. A., Siguenza -Sanchez, C. P., Donati, F., Merciai, S., Schmidt, J., Dias Rodrigues, J. F., & Tukker, A. (2019). The circularity gap of nations: A multiregional analysis of waste generation, recovery, and stock depletion in 2011. *Resources, Conservation And Recycling*, 151, 104452. doi:10.1016/j.resconrec.2019.104452

Version: Publisher's Version

License: [Creative Commons CC BY 4.0 license](https://creativecommons.org/licenses/by/4.0/)

Downloaded from: <https://hdl.handle.net/1887/83627>

Note: To cite this publication please use the final published version (if applicable).



Contents lists available at ScienceDirect

Resources, Conservation & Recycling

journal homepage: www.elsevier.com/locate/resconrec

The circularity gap of nations: A multiregional analysis of waste generation, recovery, and stock depletion in 2011



Glenn A. Aguilar-Hernandez^{a,*}, Carlos Pablo Sigüenza-Sanchez^a, Franco Donati^a, Stefano Merciai^b, Jannick Schmidt^b, João F.D. Rodrigues^a, Arnold Tukker^a

^a Institute of Environmental Sciences (CML), Leiden University, the Netherlands

^b 2.-0 LCA consultants, Denmark

ARTICLE INFO

Keywords:

Circular economy
Multiregional hybrid-units input-output tables
Material-based metrics
Circularity interventions
Resource efficiency

ABSTRACT

Due to increased policy attention on circular economy strategies, many studies have quantified material use and recovery at national and global scales. However, there has been no quantitative analysis of the unrecovered waste that can be potentially reintegrated into the economy as materials or products. This can be interpreted as the gap of material circularity. In this paper we define the circularity gap of a country as the generated waste, plus old materials removed from stocks and durable products disposed (i.e. stock depletion), minus recovered waste. We estimated the circularity gap of 43 nations and 5 rest of the world regions in 2011, using the global, multiregional hybrid-units input-output database EXIOBASE v3.3. Our results show the trends of circularity gap in accordance to each region. For example, the circularity gaps of Europe and North America were between 1.6–2.2 tonnes per capita (t/cap), which are more than twice the global average gap (0.8 t/cap). Although these regions presented the major amount of material recovery, their circularity gaps were mostly related to the levels of stock depletion. In Africa and Asia-Pacific regions, the circularity gap was characterized by a low degree of recovery and stock depletion, with high levels of generated waste. Moreover, we discuss which intervention types can be implemented to minimize the circularity gap of nations.

1. Introduction

Ensuring well-being within the planetary boundaries has become a prominent issue in the worldwide political agenda. Within this context the circular economy has emerged as a paradigm that promotes economic and environmental sustainability (Winans et al., 2017; Geissdoerfer et al., 2017; Abadia et al., 2018).

Several governments have adopted the circular economy as a key component in resource efficiency and sustainability strategies (Yuan et al., 2006; Ghisellini et al., 2016; Iacovidou et al., 2017; McDowall et al., 2017). Furthermore, to support these policies and identify priority areas in which circularity actions can be implemented effectively, it is important to quantify the degree of circularity of different products and materials (see, for example, Bastein et al., 2013; Su et al., 2013; EMF et al., 2017).

With the current policy interest in circularity actions, there is a growing body of literature that investigates recovery and waste generation at country and regional levels (Geng et al., 2012; Murray et al.,

2015). The resulting data constitute a fundamental tool for monitoring the cost-effectiveness of circular economy strategies (Haupt et al., 2016; Pauliuk, 2017; Mayer et al., 2018). We will now review the main findings of these studies.

Haas et al. (2015) provided an overview of the circularity degree of the global economy and Europe in 2005. The researchers assessed the global material circularity by measuring the ratio between waste recovery and domestic material input (the latter defined as the sum of domestic material extraction and imports). Their outcomes showed a low degree of material circularity worldwide. The low circularity of materials was explained by two main factors: 44% of resources are used for energy purposes, and almost 30% of extracted materials are accumulated as in-use stocks (i.e. material for buildings, infrastructure, and products with long lifespan). They argued that this is a major limitation for the potential of recycling as a key strategy to increase material circularity, given that there are strong technological limitations to the extent that energy products and in-use stock materials can be recirculated.

Abbreviations: CG, circularity gap; CI, circularity index; CGI, circularity gap index; CG/pc, circularity gap per capita; Gt, Gigatonnes; MR-HIOT, multiregional hybrid-units input-output tables; t/cap, tonnes per capita; w_{sup} , waste generation; w_{rec} , waste recovery; s_{dep} , stock depletion

* Corresponding author.

E-mail address: g.a.aguilar@cml.leidenuniv.nl (G.A. Aguilar-Hernandez).

<https://doi.org/10.1016/j.resconrec.2019.104452>

Received 12 November 2018; Received in revised form 14 June 2019; Accepted 15 August 2019

Available online 28 August 2019

0921-3449/© 2019 The Authors. Published by Elsevier B.V. This is an open access article under the CC BY license

(<http://creativecommons.org/licenses/by/4.0/>).

Several studies have assessed the circularity degree at country and regional levels using the economic-wide material flow analysis (EW-MFA) as a consistent framework to analyze recirculated materials (Kovanda, 2014; Nuss et al., 2017; van Eygen et al., 2017; Jacobi et al., 2018; Krausmann et al., 2018; Mayer et al., 2018). For instance, Nuss et al. (Nuss et al., 2017) applied the EW-MFA approach to identify the material circularity for individual member states of the European Union. Their findings are similar to those reported by Haas et al. (2015), in which a low degree of material circularity per country resulted from the use of materials for energy consumption and stock accumulation.

Pauliuk et al. (2017) calculated the material circularity using a dynamic input-output material flow model that considers explicitly material losses and quality. The researchers analyzed the steel scrap accumulation through different economic activities over one hundred years from vehicles in Japan, Germany and United States. They studied multiple end-of-life scenarios taking a baseline scenario with present loss rates, trade trends, and scrap waste treatment through electric arc furnace. The authors demonstrated that the baseline scenario has a circularity degree of 87%, which refers to the accumulation of steel (in tonnes) between 2015 and 2100 respect to the theoretical maximum accumulative value.

Shortly after, Nakamura et al. (2017) quantified the recycling rate and losses of alloying metals in the Japanese steel cycle. They applied a cumulative sum for the use of materials over certain time, called cumulative service index. Their findings showed that more than 70% of alloying metals, namely chromium and nickel, can be retained by the Japanese economy under a scenario of high-level scrap sorting. Together these studies, Pauliuk et al. (2017) and Nakamura et al. (2017), recognized the role of product lifetime extension and recycling rates into the analysis of material circularity.

By exploring theoretical physical limits, Cullen (2017) estimated the material recovery and energy requirements of five resource categories: steel, concrete, plastic, paper and aluminum. He proposed a material circularity index that consists in the product of two ratios, recovered materials and energy requirements: recovered materials were defined as the fraction of end-of-life materials that are recovered divided by the primary material inflow; energy requirements were defined as the proportion of the energy needed in products from recovered or recycled materials, called secondary production, as a fraction of products from virgin materials (i.e. primary production). In his approach, the degree of material circularity varied depending on the type of material. For instance, the circularity index indicated values from 4% in the case of paper to 20% for aluminum. The author suggested that the remaining percentage of the circularity index can be used as a theoretical value of the circularity potential of a material.

In a similar way, Fellner et al. (2017) determined the potential of circular economy strategies in Europe. They quantified the amount of waste that is not recovered and can be used in the future by recycling activities. The researchers also estimated the potential economic gains and reductions in carbon emissions if waste fractions that were not recovered could be transformed into secondary raw material for replacing primary resources. Their findings were similar to those reported by Haas et al. (2015), in which a limited potential of material circularity was resulted from the amount of materials that are part of the in-use stocks.

In a recent technical report, de Wit et al. (2018) quantified the global gap of material circularity for 2015. The authors first estimated the degree of circularity worldwide considering the percent share of recovered materials as part of the total resource extraction. They determined that global material circularity was less than 10%, and concluded that a theoretical gap of around 90% can potentially be recovered.

When these studies are taken into consideration, it can be noticed that the current analysis of material circularity is mostly focused on how much waste is recovered in an economy as shares of primary

material inputs. Furthermore, the current metric of circularity gap does not distinguish between the amount of materials that are emitted, added to stocks, or disposed as waste from previous in-use stocks. This last aspect limits the capacity to identify the actual waste available for circularity because the current measurement accounts for waste materials that are not available to be recovered in the present.

To enhance the circularity gap calculation, we propose a metric that focuses on the amount of unrecovered waste that can be reintegrated into the economy as materials or products. A key difference between our approach and the previous studies is that we make an explicit mathematical distinction between those materials that are added to stocks, and dispersed in the environment as dissipative emissions or other combustion and biomass residues. This allows us to identify the actual fraction of waste for material circularity in a specific period. We consider the quantity of waste generated and recovered in a period, and the old goods removed from stock and durable products disposed, defined as stock depletion (EC, 2001; Schmidt et al., 2013). Thus, the circularity gap (CG) of a nation can be defined from these parameters as the waste generation, plus stock depletion, minus recovered materials. Such a CG metric can be seen as measure of the waste materials that are theoretically available for circularity.

In this paper, we aim to determine the CG of nations considering waste generation, recovery, and stock depletion. We calculate the CG of 43 countries and 5 rest of the world regions in 2011, using the global multiregional hybrid-input-output database EXIOBASE v3 (Tukker et al., 2013, 2018; Wood et al., 2015; Stadler et al., 2018). We then discuss in which way the CG of a specific country or region can be minimized through four intervention categories: product lifetime extension, closing supply chain, resource efficiency, residual waste management (Aguilar-Hernandez et al., 2018). To the best of our knowledge, this is the first study that calculates and compares the gap of material circularity for 43 nations and 5 global regions in a consistent framework.

The paper is organized as follows: Section 2 describes the data and methods. Section 3 then shows the findings of the analysis. Sections 4 and 5 bring a discussion from the main finding, and final remarks.

2. Data and methods

In this section we report the process undertaken to quantify the circularity gap (CG) of nations. First, we define the system's boundaries for the input-output material flows of an economy. Second, we present the calculations to obtain the CG of nations considering the amount of generated waste, stock depletion, and recovered materials. Finally, we describe the EXIOBASE v3.3 database and its elements used in our analysis.

2.1. System definition

A generic diagram of the material flows in an economy is presented in Fig. 1 (Schmidt et al., 2013; Nuss et al., 2017). In the diagram, the following activities (represented as solid boxes) are considered: intermediate activities and final demand (I&C), waste treatment sectors (T), and rest of the world economy (RoW). Material stocks (presented as solid circles) are considered: stock of natural resources (N), material in-use stocks (S), and the stock of nature from domestic processed outputs (DPO). The last one comprises all material wastes that are disposed into the environment as dissipative emissions or other combustion and biomass residues (e.g. ashes and slag from fossil fuels combustion, and biomass waste from humans and livestock), as well as waste solid landfilling and incineration. The following flows (represented as solid lines) are considered: imports (m), domestic resource extraction (r), recovered or secondary materials (w_{rec}), exports (e), waste generation (w_{sup}), additions to stocks (s_{add}), stock depletion (s_{dep}). Finally, the flow of dissipative emissions, and other combustion and biomass residues caused by intermediate activities and final demand ($b_{I\&C}$), and waste

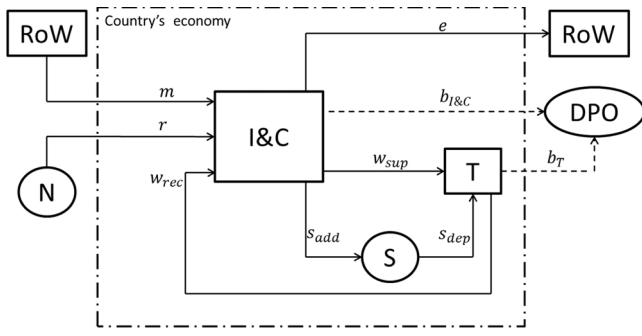

Fig. 1. System definition of the input-output material flows of a country. Solid blocks indicate economic activities of: I&C = Intermediate sectors and final demand; T = waste treatment activities; RoW = Rest of the world. Solid circles indicate resource stocks of: N = Natural resources; S = Material in-use stocks; DPO = Domestic processed output. Solid and dashed lines indicate flows of: m = imports; r = resource extraction domestically; w_{rec} = waste recovery; e = exports; s_{add} = stock additions; s_{dep} = stock depletion, w_{sup} = waste generation; $b_{I\&C}$ = dissipative emissions, others combustion and biomass residues from intermediate activities and final demand; and b_T = dissipative emissions and others combustion and biomass residues from waste treatment.

treatment (b_T) are represented as dashed lines. Waste treatment is considered as a defensive expenditure that can be required to mitigate the potential impacts of waste disposal on the environment (EC, 2000). Considering a system boundary for the global economy, Fig. 1 is adapted by deleting m and e flows, and RoW sectors due to physical trade balance to other regions (i.e. exports minus imports flows) does not occur in this context (EC, 2001).

2.2. Circularity gap calculation

For a specific period, there are three main outflows related to the amount of waste materials that can be potentially recovered as physical products: waste generation, stock depletion, and waste recovery. First, waste generation or supply (w_{sup}) represents the material/product outflows of human activity which require further treatment to be disposed of outside the technosphere (Schmidt et al., 2013; Merciai and Schmidt, 2018). Second, stock depletion (s_{dep}) expresses the amount of waste resulting from materials accumulated previously, which includes the old materials depleted from stock and durable products disposed from previous years (EC, 2001; Schmidt et al., 2013; Schmidt and Merciai, 2017). Third, waste recovery (w_{rec}) refers to all waste that is reprocessed or recycled into products or materials that are used by the economy (Haas et al., 2015; Jacobi et al., 2018). Thus, the circularity gap (CG) can be defined as all waste that is generated (from w_{sup} and s_{dep}) excluding the recovered waste (w_{rec}). That is, CG can be expressed as follows:

$$CG = w_{sup} + s_{dep} - w_{rec} \quad (1)$$

We now use CG to express the material balance of intermediate activities and final demand (I&C), and waste treatment sectors (T). From Fig. 1, I&C is mathematically expressed as:

$$m + r + w_{rec} = e + b_{I\&C} + w_{sup} + S_{add} \quad (2)$$

$$r = (e - m) + b_{I\&C} + (w_{sup} + S_{add} - w_{rec}) + (S_{add} - S_{dep}) \quad (3)$$

in which $(e - m)$ = trade denotes the physical trade balance, $(S_{add} - S_{dep})$ = NAS represents net additions to stocks. Thus, I&C material balance can be expressed as follows:

$$r = trade + b_{I\&C} + CG + NAS \quad (4)$$

where $trade = 0$ in the case of global material balance.

In a similar way, the material balance of waste treatment sectors (T) can be represented as:

$$w_{sup} + S_{dep} = w_{rec} + b_T \Leftrightarrow w_{sup} + S_{dep} - w_{rec} = b_T \Leftrightarrow CG = b_T \quad (5)$$

It is important to notice that CG represents a simplification of the time dimension and material losses. Regarding the temporal aspect, waste recovery consists of waste materials from the same period as well as those released as waste from previous years due to stock depletion (Schmidt et al., 2013). In this study, it is assumed that waste generation, stock depletion, and recovery take place in the same year, and future waste supply is the result from additions to stocks. In addition, this approach does not recognize material losses, quality, or recycling efficiency rates.

Our CG metric is based on the circularity definition proposed by Cullen (2017); Fellner et al. (2017), and de Wit et al. (2018). These studies focused on a material-oriented approach where the recovered waste is considered a circular material, and the material gap results from all materials that are not recovered in a specific period. Nevertheless, this could lead to misunderstand a circular economy as a system with zero dissipative emissions and unchanged stocks, which is rather an unrealistic and optimistic outlook of material flows. In order to avoid such a material outlook, we consider the CG only from the materials that pass through waste treatment sectors and are not reintegrated into the economy. Thus, CG can be considered as the theoretical amount of waste that is not used in a circular way.

Following previous material circularity approaches (Haas et al., 2015; de Wit et al., 2018; Mayer et al., 2018), the circularity index (CI) for a specific country or region can be expressed as:

$$CI = \frac{w_{rec}}{r + m} \times 100 \quad (6)$$

in which $r + m$ denotes the domestic material input of intermediate activities and final demand (I&C). Similarly, we can represent a circularity gap index (CGI) of a nation as follows:

$$CGI = \frac{CG}{w_{sup} + s_{dep}} \times 100 \quad (7)$$

$$CGI = \frac{CG}{(w_{sup} + s_{dep} - w_{rec}) + w_{rec}} \times 100 \Leftrightarrow CGI = \frac{CG}{CG + w_{rec}} \times 100 \quad (8)$$

2.3. Global, multiregional hybrid input-output table from EXIOBASE v3.3

Data from the global, multiregional hybrid-units input-output table (MR-HIOTs) EXIOBASE version 3.3.15. was used to estimate the CG of 43 countries and 5 rest of the world regions in 2011 (Tukker et al., 2013; Wood et al., 2015; Stadler et al., 2018). The transactions shown in the database are expressed in mixed units: tonnes for physical values, euros for economic terms, and terajoules for energy (Merciai and Schmidt, 2018). We performed the CG calculation using the EXIOBASE v3.3.15 extension accounts of waste supply and use, stock additions and depletion, emissions, and domestic material extraction.

Our CG approach strongly depends on the capacity of determining stock additions and depletion. It is important to notice that the hybrid units input-output approach differs from a traditional monetary input-output tables, where net additions to stocks are usually allocated to final demand categories as changes in inventories and fixed capital formation (Hubacek and Giljum, 2003; Suh, 2004; Dietzenbacher, 2005; Weisz and Duchin, 2006; Eurostat, 2008). Instead, the stock addition and depletion in MR-HIOTs EXIOBASE v3.3.15 are part of the material balance from the resources, dissipative emissions, and waste. The construction of stock addition account results from mass balance checks throughout 5 integrated sections, which comprise: agriculture, energy, technical coefficient, trade, and balancing modules (Schmidt and Merciai, 2017; Merciai and Schmidt, 2018; Geerken et al., 2019). In the same way described by Suh et al. (2010) and Eurostat (2013a) for physical input-output tables, stock additions in MR-HIOTs EXIOBASE v3.3.15 represents the actual material added to the economy's stocks,

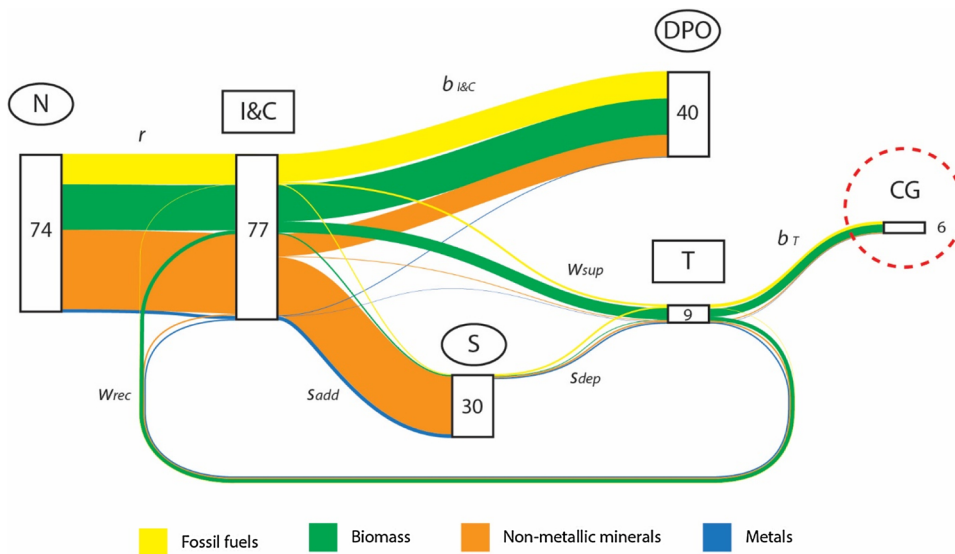

Fig. 2. Sankey diagram of global material extraction, waste, and emission flows in 2011. Numbers indicate the size of flows in Gigatonnes (Gt). Solid blocks indicate economic activities of: I&C = Intermediate sectors and final demand; T = waste treatment activities. Solid circles indicate resource stocks of: N = Natural resources; S = Material in-use stocks; DPO = Domestic processed output. Colored lines indicate flows of: r = material extraction; w_{rec} = waste recovery; s_{add} = stock additions; s_{dep} = stock depletion; w_{sup} = waste generation; $b_{I&C}$ = dissipative emissions, others combustion and biomass residues from intermediate activities and final demand; and b_T = dissipative emissions and others combustion and biomass residues from waste treatment. Dashed circle denotes circularity gap (CG). Note: RoW, m , and e are not shown in this figure because physical trade balance does not appear in the global material flow.

and stock depletion refers to materials removed from stock as demolished buildings, and disposed durable goods.

To identify waste recovery flows, we focused on 19 activities related to re-processing, recycling, biogasification, and composting products. Based on the Ellen MacArthur Foundation (EMF, 2013) and Bocken et al. (2016) material archetypes for circularity, we considered the energy recovery from waste incineration as an activity that leads to material leakage on an economy, and it should be minimized in a circular economy context. Thus, we did not include waste incineration as part of the material recovery sectors.

In order to visualize the input-output flows of materials and CG worldwide, we created a Sankey diagram based on the Economy-wide Material Loop Closing framework (Mayer et al., 2018). From MR-HIOTs EXIOBASE v3.3.15 extension accounts, we organized 39 resource extraction, 17 material waste, and 66 emission categories into four material groups: biomass, fossil fuels, metals, and nonmetallic minerals. Processed materials (including for energy and material use) are aggregated in the block of intermediate activities and final demand (I&C) as shown in Fig. 1.

In MR-HIOTs EXIOBASE v3.3.15, the account of resources for agriculture includes the production of biomass residues (Schmidt and Merciai, 2017). Thus, we considered the residual crops supply as part of the biomass balance. Furthermore, we estimated the amount of unregistered waste per material category and allocated it to domestic processed output (DPO).

We did not include the extraction of oxygen from air and the water consumption of humans and livestock. To exclude these resources (oxygen and water) from the global mass balance, we applied the coefficients of relative mass to convert CO_2 emissions from the combustion of fossil and biogenic resources to the actual extracted carbon equivalent (see Schmidt et al., 2010). In a similar way, metals are measured in terms of the content of material in the respective ores. This means that we considered the coefficients of metal concentrates in ores excluding the amount of unused and mining waste. Furthermore, waste trade (or the shipment of waste as defined by Eurostat (2013b)) was not incorporated due to the lack of data on international waste trade (Schmidt et al., 2013). Our results are presented in terms of dry matter content.

For comparing the national and regional CG's, we presented the CG calculation by region and in per capita terms. We retrieved the world's population and GDP-PPP (in 2011 current international US-dollars) datasets from the World Bank Open Data (2019a), and integrated into the MR-HIOTs EXIOBASE v3.3.15 for 2011.

2.4. Cross-country, regression analysis

We performed a cross-country, regression analysis of CG and gross domestic product, purchasing power parity (GDP-PPP) per capita in order to analyze the relation between CG and income groups. Regression analysis has been applied to assess the link of material and waste generation with affluence across countries and regions (see, for example, Wiedmann et al., 2015; Tisserant et al., 2017). In a similar way, we expressed the relation between CG and GDP-PPP per capita category can be expressed as follows:

$$CG/cap = k(GDP/cap)^\alpha \quad (10)$$

$$\log(CG/cap) = \log(k) + \alpha \log(GDP/cap) \quad (11)$$

where CG/cap represents the circularity gap per capita; GDP/cap denotes GDP-PPP per capita; α is the elasticity coefficient; and $\log(k) = \beta$ is a constant parameter in the linear model. In this case, the elasticity α expresses the percentage change in CG/cap change as response to a 1% change in $GDP-PPP/cap$ (Gujarati, 2003). We categorized each country and region by income group according to the World Bank Atlas method (2019b).

Data source, a detailed list of resource/waste/emission classifications as well as the Python code used for the analysis are provided in supplementary materials.

3. Results

In 2011, the global economy required 74 Gigatonnes (Gt) of extracted materials (see Fig. 2). Total waste generation amounted to 9 Gt, of which 25% was from stock depletion and 75% from waste generated in the same period. Moreover, global material outputs were mostly allocated to stock additions (30 Gt), and directly dissipated as emissions or other combustion and biomass residues to the environment (40 Gt). These results are similar to those reported by material use studies, which reported values per year between 66–78 Gt of global material extraction, 30–36 Gt of stock additions, and 1–4 Gt of recovered solid waste in periods from 2007 to 2010 (Weisz et al., 2006; Giljum et al., 2015; Wiedmann et al., 2015; Krausmann et al., 2017; Tisserant et al., 2017). Likewise, we observe a low degree of material circularity for 2011, which is comparable to that described by Haas et al. (2015), and de Wit et al. (de Wit et al., 2018).

Regarding the circularity gap (CG) worldwide, there is around 6 Gt (or 0.8 tonnes per capita) of unrecovered waste that can be potentially reintegrated into the global economy as secondary materials or

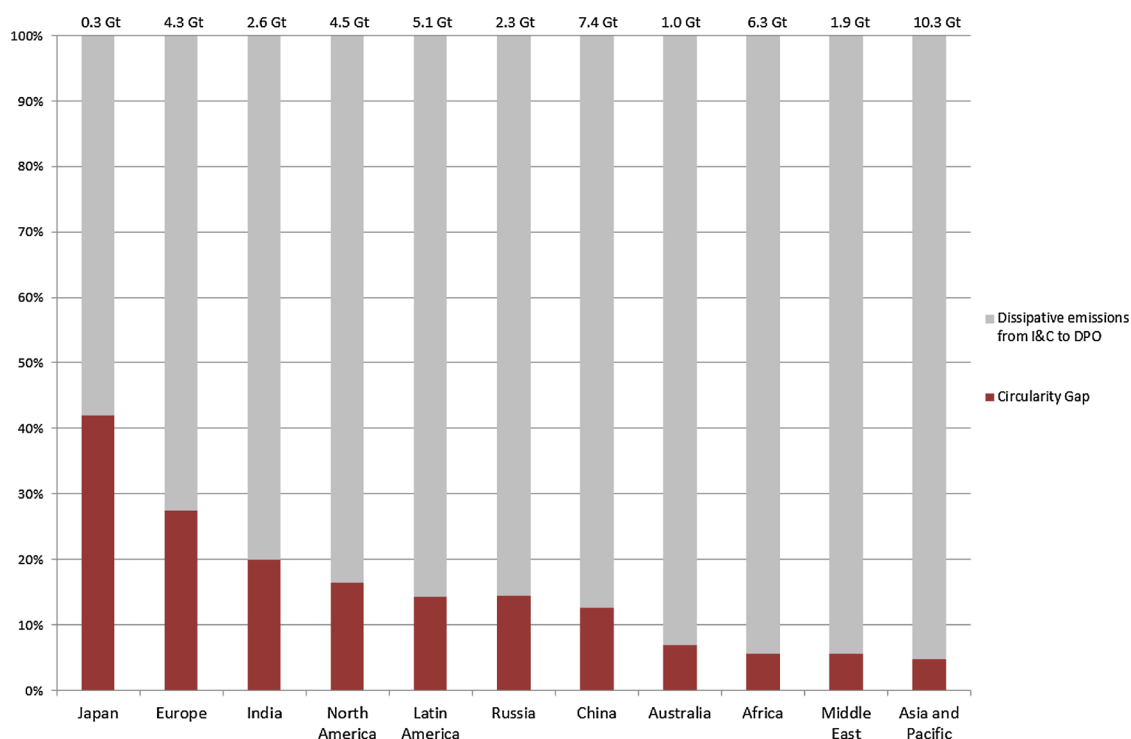

Fig. 3. Composition of domestic processed output (DPO) for selected regions and countries in 2011. Upper values represent the sum of all material outputs (i.e. dissipative emissions, and other combustion and biomass residues caused by intermediate activities and final demand ($b_{I\&C}$), and the circularity gap (CG)) in Gigatonnes (Gt).

products. This value represents an 8% share of the global material extraction. We can see that the global CG in 2011 was relatively low compared to the material output that go to stock additions, and dissipative emissions and other combustion and biomass residues. Remarkably, the global economy presented a high level of stock accumulation from construction materials (90% of the total stock additions). Thus, without considering future waste generated from current additions to stocks, there was only a small fraction of unrecovered waste that could be potentially used for material circularity in 2011.

The global trend of material outputs also applied to specific countries and regions. Fig. 3 presents the proportion of domestic processed output (DPO) in 5 countries and 6 aggregated regions (see 'exio_class' Excel file in supporting information for more details about the region categories). DPO comprises the sum of dissipative emissions, and other combustion and biomass residues caused by intermediate activities and final demand ($b_{I\&C}$), and the circularity gap (CG). In each country/region, more than 60% of DPO resulted from emissions and other residues to cause by intermediate activities and final consumption, especially for energy purposes. We observe that the material flow patterns are similar across countries and regions, where the circularity gap is minuscule compared to the sum of dissipative emissions and other combustion/biomass residues. For instance, the CG of Australia, Africa, Middle East and Asian-Pacific region constituted less than 10% of DPO in these nations.

Table 1 presents a comparison of the traditional material gap expressed as $100 - \text{Circularity Index (CI)}$, and circularity gap index (CGI) for the selected regions and countries in 2011 (see Eq. (6) and (8) in method section). The new CGI allows to support the interpretation of traditional CI. For instance, the global CI in 2011 was around 4%, which represented the fraction of waste recovery compared to the total material input. Following the traditional approach (Fellner et al., 2017; de Wit et al., 2018), it would be interpreted that there was a material gap of 96% respect to total material input in 2011. However, this approach did not distinguish the fractions of material input that were added to stocks, and dispersed into the environment as dissipative

Table 1

Traditional material gap represented as $100 - \text{Circularity Index (CI)}$, and circularity gap index (CGI) for the world, and selected regions and countries in 2011.

Region	$100 - \text{Circularity Index (CI)}$ in %	Circularity Gap Index (CGI), in %
World	95,8	18,9
Japan	91,8	26,0
Europe	92,3	26,6
India	94,9	38,1
North America	96,0	30,3
Latin America	96,5	47,4
Africa	96,6	40,6
China	97,1	6,8
Australia	97,5	60,5
Russia	97,6	62,2
Asia and Pacific	98,1	20,0
Middle East	98,7	6,5

emissions, and other residues from intermediate and final demand. Instead of a 96% global material gap, our CGI approach shows that around 19% of material wastes passed through waste treatment sectors, and were not reintroduced into the economy as recovered materials. The new CGI only considers the fraction of waste that is recovered and reintegrated into the economy, and, thus, it allows to determine the actual fraction of material waste that is not used in a circular manner.

Furthermore, a comparison of $100 - \text{CI}$ and CGI between countries/regions can bring insights about the structure of waste treatment activities in an economy. For instance, the traditional approach for material gap indicates that Japan generated less output of waste per unit of total material input ($100 - \text{CI} = 92\%$) compared to China ($100 - \text{CI} = 97\%$). In contrast, using the new CGI, our findings show that the fraction of residual waste generated by waste treatment activities in China (CGI = 7%) was more than 3 times smaller than in Japan (CGI = 26%).

Turning now to the CG at national and regional levels, we identify

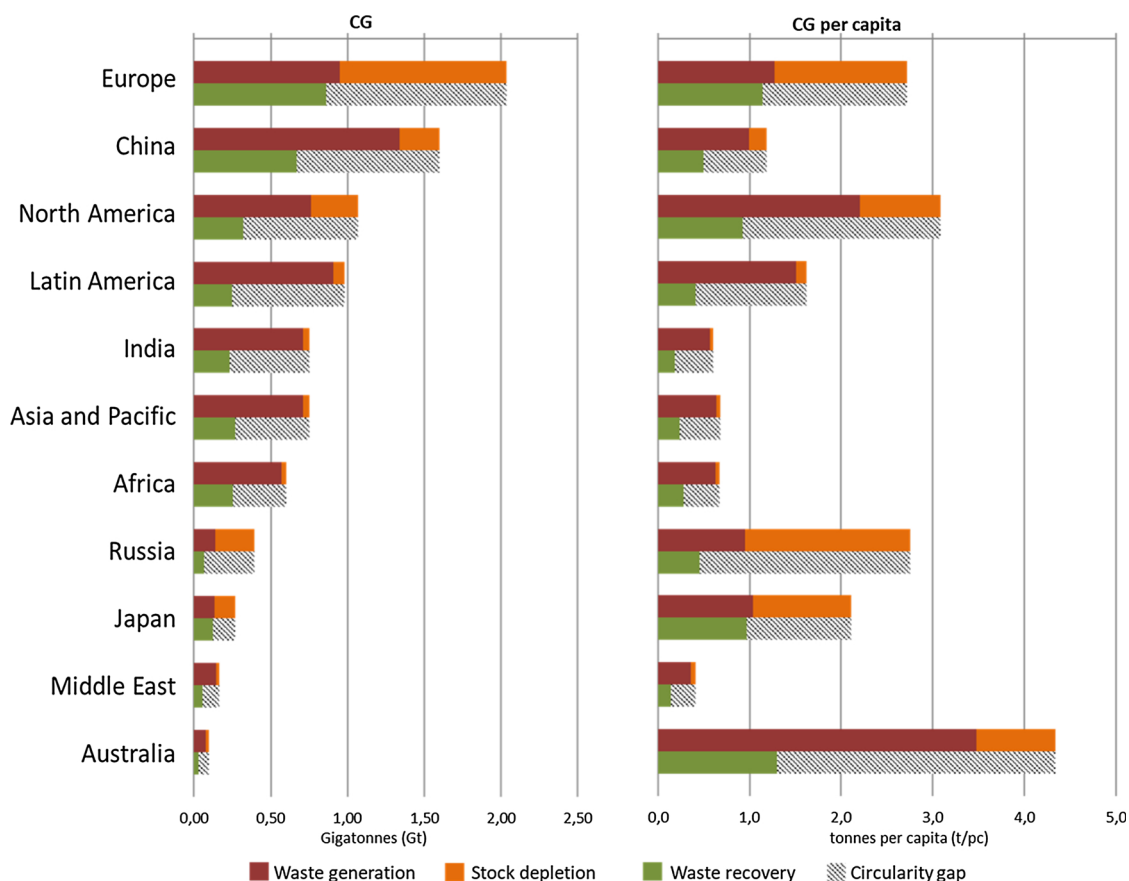

Fig. 4. Circularity gap (CG, in totals and per capita) of selected regions and countries in 2011.

the trends of unrecovered waste in each country or region. Fig. 4 shows a breakdown (CG) organized by the selected countries and aggregated regions. CG results for 2011 all countries studied are provided in supplementary materials.

Europe showed the highest circularity gap in absolute values (1.2 Gt) and the fourth largest gap per capita (1.6 tonnes per capita, i.e., t/cap), even when European countries had the highest values of recovered waste (1.1 t/cap). Such CGs resulted from the high level of stock depletion that was five times larger than the global stock depletion average in 2011 (i.e. 0.3 t/cap). We observed similar trends in the CG of other high and upper middle income nations (for example, Japan, Australia, Russia, USA and Canada), where a major CG was presented in countries with a high level of waste recovery, but also larger stock depletion. In comparison with the global average (0.8 t/cap), the CG of these economies were between two and four times bigger than the CG worldwide.

In absolute terms, China had the second highest CG corresponding to 0.9 Gt for 2011. In this case, the Chinese economy recovered around 44% of the total waste available (1.6 Gt). While the amount of waste generation (1.0 t/cap) was slightly higher than world average, the depletion of stocks in China (0.2 t/cap) was similar to the values of medium and low income regions (less than 0.1 t/cap of stock depletion). The low degree of depleted stocks in China can be explained as a result of a phase of economic growth characterized by increasing stock accumulation (Krausmann et al., 2017, 2018), which was the trend of material flow for upper high income economies (such as Latin America region). Thus, we could expect an increment in future waste in China resulting from the erosion of present accumulated stocks (Schmidt and Merciai, 2017).

Africa, Middle East, and Asia-Pacific regions were characterized by a smaller CG, which presented an average of 0.4 t/cap. These regions also presented a common trend in terms of waste generation, recovery,

and stock depletion. In comparison with the world average, middle to lower income nations showed lower values of stock depletion and recovered waste (less than 0.1 t/cap and 0.3 t/cap, respectively), with higher waste generation (between 0.4 and 0.6 t/cap). In general, most of the CG in middle, upper lower and lower income countries came from waste generation, which can be related to three aspects: a low capacity of residual waste management, the consumption of products with short lifetimes, and a growing of addition to stocks.

Fig. 5 presents the cross-country, regression analysis of CG and gross domestic product, purchasing power parity (GDP-PPP) per capita including all 43 countries and 5 rest of world regions in 2011 (see equation (11) in method section). This analysis shows that there is a positive relation between CG per capita and income groups, in which a change of 1.0% in GDP-PPP per capita would drive a change of 0.9% in CG per capita ($\alpha = 0.9$). Although the positive link between CG and GDP-PPP per capita, the correlation of both parameters is unclear ($R^2 = 0.272$). A low correlation coefficient of CG and GDP-PPP per capita can be explained by the differences of economic structure across regions, and a lack of data coverage in the database (Tisserant et al., 2017).

4. Discussion

The purpose of this study was to estimate the circularity gap (CG) of countries, which in turns CG as generated waste, plus depleted stocks, minus recovered waste in a specific period. This CG metric allows to identify the trends of multiple regions, and the theoretical values of unrecovered waste that can be reintegrated as goods that substitute resource extraction. Moreover, our results may help us to understand which actions can be applied to contribute to circular economy policies. We now focus on interventions that can be implemented to enhance material circularity from changes in CG.

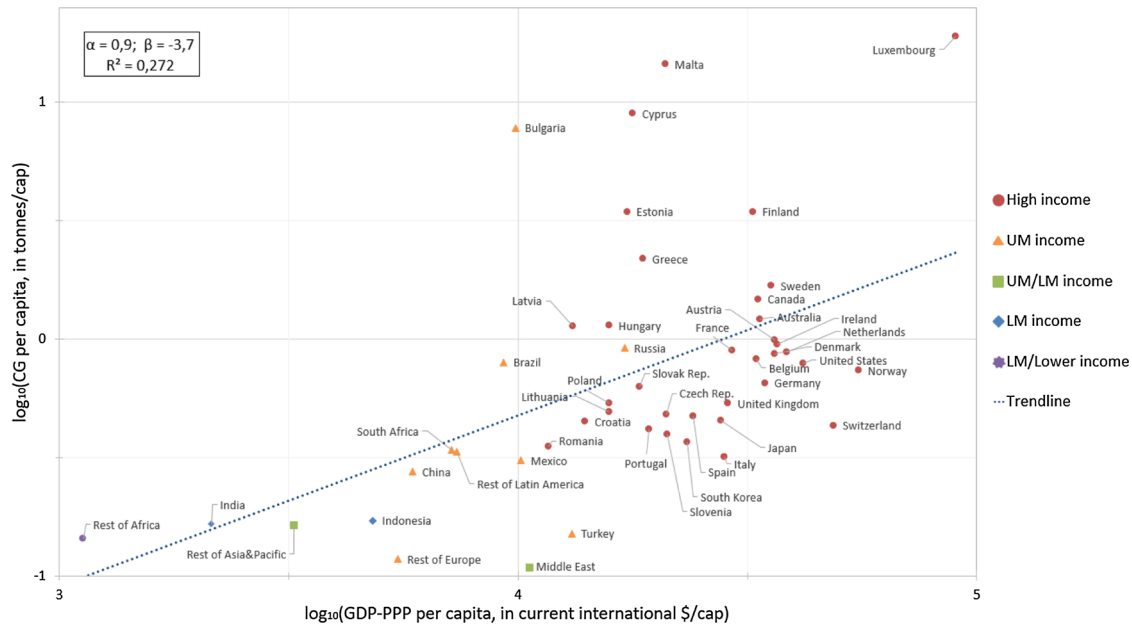

Fig. 5. Logarithm of circularity gap per capita (CG/cap, in tonnes/cap) over logarithm of gross domestic product, purchasing power parity per capita (GDP-PPP/cap, in current international \$/cap). Red circle indicates high income country. Orange triangle indicates upper middle income (UM income). Green square indicates upper middle and lower middle income (UM/LM income). Blue diamond indicates lower middle income (LM income). Purple 6-point star indicates lower middle and lower income (LM/Lower income). Dark blue dot line denotes the regression trendline, α is the elasticity, β is a constant parameter, and R^2 is the standard coefficient of determination (For interpretation of the references to colour in this figure legend, the reader is referred to the web version of this article).

4.1. Opportunities of CG reduction through circularity interventions

In general, CG is a representation of the waste that can be potentially recovered for material circularity. Thus, we can expect an improvement of material circularity if a decrease of CG is made by a country/region. Considering the definition of CG used in this study, there are three ways to reduce a country’s CG: increasing waste recovery, decreasing waste generation, and reducing stock depletion.

In order to change the material flows related to CG reduction (i.e. generated waste, depleted stocks, and recovered materials), specific circular economy strategies that aim to retain materials in a closed-loop economic system should be implemented (EMF, 2013; Bocken et al., 2016; Blomsma and Brennan, 2017; Kirchherr et al., 2017; Geissdoerfer et al., 2017). Such a set of strategies, also called circularity interventions, have been categorized in four groups: residual waste management, closing supply chains, resource efficiency, and product lifetime extension.

Waste recovery can be increased through residual waste management. This intervention type is focused on strategies at the end-of-life of products, in which materials are disposed outside the economic system (EMF, 2013; Kirchherr et al., 2017). An increase of waste recovery would imply the replacement of landfill and incineration processes with recycling activities. This can contribute to material circularity in countries with a low degree of waste recovery, which is particularly the case of middle, upper lower and lower income economies.

In terms of waste generation, there are two interventions that can be considered: closing supply chains, and resource efficiency. Closing supply chains are the strategies of re-integrating materials at different levels of the supply chain after their initial use phase. This intervention category is implemented by: using a product one more time for the same purpose (product reuse), taking reusable components and rebuilding a new product (component reuse), substituting or repairing major parts in order to return a product to its working condition (re-furbishment), and material reuse as material recycling (EMF, 2013; EMF et al., 2017). Resource efficiency refers to actions that improve

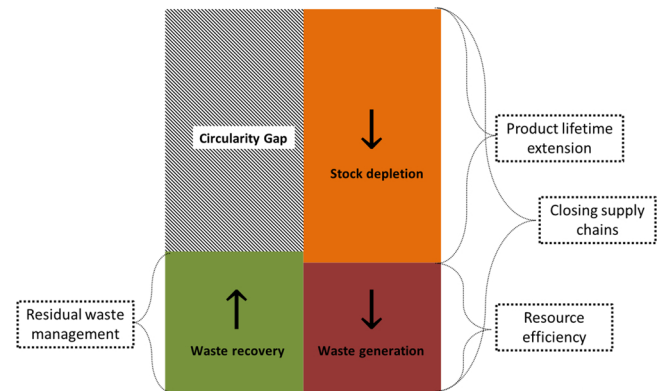

Fig. 6. A circularity gap reduction through four intervention types. Green, red, and orange squares indicate material recovery, waste generation, and stock depletion, respectively. Area with black/white diagonal lines represents the circularity gap. White square with dots line border ('...') represents circularity intervention type. '↑' indicates an increase of material flow, '↓' indicates a decrease or delay of waste flow (For interpretation of the references to colour in this figure legend, the reader is referred to the web version of this article).

material flows through the use of less resources per unit of total output, which can contribute to waste reduction in specific activities (Bocken et al., 2016; Zhu et al., 2018). Together these interventions can contribute to decrease waste generation by improving material use. In fact, recent policies have been mostly focused on targets related to reducing waste as well as resource efficiency in high and upper high income countries, such as the circularity interventions proposed by European Union and China (see, for example, Su et al., 2013; McDowall et al., 2017; Zhu et al., 2018).

The decrease or delay of waste from previous stocks can be achieved through product lifetime extension. Such an intervention focuses on the design for longevity and maintenance of durable goods (Bocken et al., 2016; Kirchherr et al., 2017). It is expected that a significant amount of future waste will be generated due to the depletion in-use stocks from

building and infrastructure activities, especially in high and upper high income countries, where there is a high degree of stock additions every year (Haas et al., 2015; Krausmann et al., 2017, 2018). Instead of interventions addressing material flows, delaying stock depletion should be focused on stock management, in which extending product lifetime will prevent the erosion of durable products (Stanhel and Cliff, 2015). Likewise, it is important to notice that accumulated stocks and the time frame for future waste recovery should be considered as part of the intervention. On the other hand, closing supply chains can contribute to delaying stock depletion if the intervention of product life extension through product and component reuse is applied to extend the use phase of products.

4.2. Further steps

In this study the CG per country was calculated through a global multiregional hybrid-input-output tables (MR-HIOTs). The MR-HIOTs have been recognized as a consistent framework for assessing circularity interventions at macro-scale (Tisserant et al., 2017; Aguilar-Hernandez et al., 2018). However, applying MR-HIOTs is restricted by model's staticity, the misrepresentation of feedback from nature to the economy, as well as the in-use stocks dynamics (de Koning, 2018d; Wiedenhofer et al., 2019). Considering these limitations, three main elaborations for the future assessments of CG of nations follow.

First, estimating the actual generated waste from stock can be improved through dynamic MR-HIO model. This aspect would include materials that are becoming waste from previous years, as well as the time in which present waste will be released (Schmidt and Merciai, 2017). Likewise, a dynamic approach allows to evaluate resource duration and longevity (i.e. length of time a material is used), which are recognized as important factors for assessing circularity (Franklin-Johnson et al., 2016; Figge et al., 2018). Dynamic input-output and material flow models have been already developed (see, for example, Duchin and Levine, 2013; Pauliuk et al., 2017; Wiedenhofer et al., 2019), however, there is no estimation of CG related to the dynamic of stocks. Then, a more sophisticated metric should allow, for instance, to look at which potential use is made of life time extension, re-use and refurbishing of entire products or product components.

Second, to demonstrate whether the management of CG could contribute to separate environmental impacts from economic growth, assessing material circularity should reflect whether decoupling is achieved. Only recently a few studies have analyzed the impacts of resource use at global scale considering relative or absolute decoupling from nature (for example, Behrens et al., 2007; Wiedmann et al., 2015; Schandl et al., 2016; Tukker et al., 2016). These studies argue that the increase of international trade plays an important role on material efficiency and environmental sustainability, showing that environmental impacts have been offset from industrialized countries to emerging and low-income economies (Tukker et al., 2016; Wood et al., 2018). An assessment related to CG and the relation to decoupling could improve the understanding of potential environmental benefits generated by circularity transition.

Finally, MR-HIOTs should be enhanced in terms of waste accounts. At this moment, such accounting system is limited by a lack of information about waste and recovery international trades, and recognizing the quality of waste for future recovery fractions (Schmidt and Merciai, 2017). This implies that the actual CG can be lower than it is expected. Likewise, waste accounts do not include informal or illegal waste treatment sectors (Tisserant et al., 2017), which could affect the CG calculation by underestimating the actual gap.

Although further development is needed for assessing the full material capacity of a nation, this study allowed to identify the main factors of CG in a period and which interventions can be applied in a specific country or region. Moreover, we consider that the CG approach can be used as a starting point for discussing the meaning of the potential of material circularity at national and regional level, which can

lead to best practices to quantify material CG and its potential for improving resource use.

5. Conclusions

This study estimated the circularity gap (CG) of nations by using MR-HIOTs from EXIOBASE v3.3 database. We identified the CG trends of 43 countries and 5 rest of the world regions in 2011. Furthermore, we discussed which intervention types can be applied in order to improve the material circularity of a country or region.

Further steps on assessing circularity potential are required in order to enhance the analysis. We recognized that major contributions can be developed by: considering the stocks' dynamic aspects; a relation between circularity, resource efficiency and decoupling; and accounting systems with international trades of waste and recovery. Together these aspects can be integrated into future research for bringing a better understanding on what would be the potential of a global circular economy from a material-based perspective.

Funding

Glenn A. Aguilar-Hernandez is part of the Circular European Economy Innovative Training Network (CircEuit), funded by the European Commission under the Horizon 2020 Marie Skłodowska Curie Action 2016 (Grant Agreement Number 721909).

Declaration of Competing Interest

The authors have no competing interests to declare.

Acknowledgements

We thank two anonymous reviewers that have contributed to improving the quality of the paper. We also thank Di Dong for her insightful suggestions on visualization.

Appendix A. Supplementary data

Supplementary data associated with this article can be found, in the online version, at <https://doi.org/10.1016/j.resconrec.2019.104452>.

References

- Abadia, L.G., Carvalho, M.M., Homrich, A.S., Galv, G., 2018. The circular economy umbrella: trends and gaps on integrating pathways. *J. Clean. Prod.* 175, 525–543. <https://doi.org/10.1016/j.jclepro.2017.11.064>.
- Aguilar-Hernandez, G.A., Sigüenza-Sanchez, C.P., Donati, F., et al., 2018. Assessing circularity interventions: a review of EIOA-based studies. *J. Econ. Struct.* 7, 1–24. <https://doi.org/10.1186/s40008-018-0113-3>.
- Bastein, T., Roelofs, E., Rietveld, E., Hoogendoorn, A., 2013. Opportunities for a Circular Economy in the Netherlands. Technical Report.
- Behrens, A., Giljum, S., Kovanda, J., Niza, S., 2007. The material basis of the global economy. Worldwide patterns of natural resource extraction and their implications for sustainable resource use policies. *Ecol. Econ.* 64, 444–453. <https://doi.org/10.1016/j.ecolecon.2007.02.034>.
- Blomsma, F., Brennan, G., 2017. The emergence of circular economy. A new framing around prolonging resource productivity. *J. Ind. Ecol.* 21, 603–614. <https://doi.org/10.1111/jiec.12603>.
- Bocken, N.M.P., de Pauw, I., Bakker, C., van der Grinten, B., 2016. Product design and business model strategies for a circular economy. *J. Ind. Prod. Eng.* 33, 308–320. <https://doi.org/10.1080/21681015.2016.1172124>.
- Cullen, J.M., 2017. Circular economy: theoretical benchmark or perpetual motion machine? *J. Ind. Ecol.* 0, 1–4. <https://doi.org/10.1111/jiec.12599>.
- de Koning, A., 2018d. Creating Global Scenarios of Environmental Impacts With Structural Economic Models. Leiden University.
- de Wit, M., Hoogzaad, J., Ramkumar, S., et al., 2018. The Circularity Gap Report. An Analysis of the Circular State of the Global Economy. Technical Report.
- Dietzenbacher, E., 2005. Waste treatment in physical input-output analysis. *Ecol. Econ.* 55, 11–23. <https://doi.org/10.1016/j.ecolecon.2005.04.009>.
- Duchin, F., Levine, S.H., 2013. Embodied resource flows in a global economy: an approach for identifying the critical links. *J. Ind. Ecol.* 17, 65–78. <https://doi.org/10.1111/j.1530-9290.2012.00498.x>.

- EC, 2001. Economy-Wide Material Flow Accounts and Derived Indicators. Technical Report. Luxembourg. .
- EC, 2000. Analysis of the Fundamental Concepts of Resource Management. Technical Report. Luxembourg. .
- EMF, 2013. Toward the Circular Economy. Technical Report. .
- EMF, SUN, SYSTEMIQ, 2017. Achieving Growth Within. Technical Report. .
- Eurostat, 2008. Eurostat Manual of Supply, Use and Input-Output Tables. Luxembourg. .
- Eurostat, 2013a. Economy-Wide Material Flow Accounts (EW-MFA) Compilation Guide 2013.
- Eurostat, 2013b. Manual on Waste Statistics: A Handbook for Data Collection on Waste Generation and Treatment. Luxembourg. .
- Lederer, J., Fellner, J., Scharff, C., Laner, D., 2017. Present potentials and limitations of a circular economy with respect to primary raw material demand. *J. Ind. Ecol.* 21, 494–496. <https://doi.org/10.1111/jiec.12582>.
- Figge, F., Thorpe, A.S., Givry, P., et al., 2018. Longevity and circularity as indicators of eco-efficient resource use in the circular economy. *Ecol. Econ.* 150, 297–306. <https://doi.org/10.1016/j.ecolecon.2018.04.030>.
- Franklin-Johnson, E., Figge, F., Canning, L., 2016. Resource duration as a managerial indicator for circular economy performance. *J. Clean. Prod.* 133, 589–598. <https://doi.org/10.1016/j.jclepro.2016.05.023>.
- Geerken, T., Schmidt, J., Boonen, K., et al., 2019. Assessment of the potential of a circular economy in open economies — case of Belgium. *J. Clean. Prod.* <https://doi.org/10.1016/j.jclepro.2019.04.120>.
- Geissdoerfer, M., Savaget, P., Bocken, N.M.P., Hultink, E.J., 2017. The circular economy — a new sustainability paradigm? *J. Clean. Prod.* 143, 757–768. <https://doi.org/10.1016/j.jclepro.2016.12.048>.
- Geng, Y., Fu, J., Sarkis, J., Xue, B., 2012. Towards a national circular economy indicator system in China: an evaluation and critical analysis. *J. Clean. Prod.* 23, 216–224. <https://doi.org/10.1016/j.jclepro.2011.07.005>.
- Ghisellini, P., Cialani, C., Ulgiati, S., 2016. A review on circular economy: the expected transition to a balanced interplay of environmental and economic systems. *J. Clean. Prod.* 114, 11–32. <https://doi.org/10.1016/j.jclepro.2015.09.007>.
- Giljum, S., Bruckner, M., Martinez, A., 2015. Material footprint assessment in a global input-output framework. *J. Ind. Ecol.* 19, 792–804. <https://doi.org/10.1111/jiec.12214>.
- Gujarati, D.N., 2003. *The nature of regression analysis. Basic Econometrics, fourth ed.* McGraw-Hill, pp. 17–24.
- Haas, W., Krausmann, F., Wiedenhofer, D., Heinz, M., 2015. How circular is the global economy? An assessment of material flows, waste production, and recycling in the European union and the world in 2005. *J. Ind. Ecol.* 19, 765–777. <https://doi.org/10.1111/jiec.12244>.
- Haupt, M., Vadenbo, C., Hellweg, S., 2016. Do we have the right performance indicators for the circular economy? Insight into the Swiss waste management system. *J. Ind. Ecol.* 21. <https://doi.org/10.1111/jiec.12506>.
- Hubacek, K., Giljum, S., 2003. Applying physical input-output analysis to estimate land appropriation (ecological footprints) of international trade activities. *Ecol. Econ.* 44, 137–151. [https://doi.org/10.1016/S0921-8009\(02\)00257-4](https://doi.org/10.1016/S0921-8009(02)00257-4).
- Iacovidou, E., Velis, C.A., Purnell, P., et al., 2017. Metrics for optimising the multi-dimensional value of resources recovered from waste in a circular economy: a critical review. *J. Clean. Prod.* 166, 910–938. <https://doi.org/10.1016/j.jclepro.2017.07.100>.
- Jacobi, N., Haas, W., Wiedenhofer, D., Mayer, A., 2018. Providing an economy-wide monitoring framework for the circular economy in Austria: status quo and challenges. *Resour. Conserv. Recycl.* 137, 156–166. <https://doi.org/10.1016/j.resconrec.2018.05.022>.
- Kirchherr, J., Reike, D., Hekkert, M., 2017. Conceptualizing the Circular Economy: An Analysis of 114 Definitions. <https://doi.org/10.1016/j.resconrec.2017.09.005>.
- Kovanda, J., 2014. Incorporation of recycling flows into economy-wide material flow accounting and analysis: a case study for the Czech Republic. *Resour. Conserv. Recycl.* 92, 78–84. <https://doi.org/10.1016/j.resconrec.2014.08.006>.
- Krausmann, F., Lauk, C., Haas, W., Wiedenhofer, D., 2018. From resource extraction to outflows of wastes and emissions: the socioeconomic metabolism of the global economy, 1900–2015. *Glob. Environ. Change* 52, 131–140. <https://doi.org/10.1016/j.gloenvcha.2018.07.003>.
- Krausmann, F., Wiedenhofer, D., Lauk, C., et al., 2017. Global socioeconomic material stocks rise 23-fold over the 20th century and require half of annual resource use. *PNAS* 114, 21–26. <https://doi.org/10.1073/pnas.1613773114>.
- Mayer, A., Haas, W., Wiedenhofer, D., et al., 2018. Measuring progress towards a circular economy a monitoring framework for economy-wide material loop closing in the EU28. *J. Ind. Ecol.* 0, 1–15. <https://doi.org/10.1111/jiec.12809>.
- McDowall, W., Geng, Y., Huang, B., et al., 2017. Circular economy policies in China and Europe. *J. Ind. Ecol.* 21, 651–661. <https://doi.org/10.1111/jiec.12597>.
- Merciai, S., Schmidt, J., 2018. Methodology for the construction of global multi-regional hybrid supply and use tables for the EXIOBASE v3 database. *J. Ind. Ecol.* 0, 1–16. <https://doi.org/10.1111/jiec.12713>.
- Murray, A., Skene, K., Haynes, K., 2015. The circular economy: an interdisciplinary exploration of the concept and application in a global context. *J. Bus. Ethics* 140, 369–380. <https://doi.org/10.1007/s10551-015-2693-2>.
- Nakamura, S., Kondo, Y., Nakajima, K., et al., 2017. Quantifying recycling and losses of Cr and Ni in steel throughout multiple life cycles using matrace-alloy. *Environ. Sci. Technol.* 51, 9469–9476. <https://doi.org/10.1021/acs.est.7b01683>.
- Nuss, P., Gian Andrea, B., Willi, H., et al., 2017. Development of a Sankey Diagram of Material Flows in the EU Economy Based on Eurostat. Technical Report. Luxembourg. .
- Pauliuk, S., 2017. Critical appraisal of the circular economy standard BS 8001:2017 and a dashboard of quantitative system indicators for its implementation in organizations. *Resour. Conserv. Recycl.* 129, 81–92. <https://doi.org/10.1016/j.resconrec.2017.10.019>.
- Nakamura, S., Pauliuk, S., Kondo, Y., Nakajima, K., 2017. Regional distribution and losses of end-of-life steel throughout multiple product life cycles — insights from the global multi-regional MaTrace model. *Resour. Conserv. Recycl.* 116, 84–93. <https://doi.org/10.1016/j.resconrec.2016.09.029>.
- Schandl, H., Hatfield-Dodds, S., Wiedmann, T., et al., 2016. Decoupling Global Environmental Pressure and Economic Growth: Scenarios for Energy Use, Materials Use and Carbon Emissions. <https://doi.org/10.1016/j.jclepro.2015.06.100>.
- Schmidt, J., Merciai, S., 2017. Physical/Hybrid Supply and Use Tables. Methodological Report. DESIRE deliverable. .
- Schmidt, J., Merciai, S., Delahaye, R., et al., 2013. Recommendation of Terminology, Classification, Framework of Waste Accounts and MFA, and Data Collection Guideline. CREEA deliverable D4.1. .
- Schmidt, J.H., Weidema, B.P., Suh, S., 2010. Documentation of the Final Model Used for the Scenario Analyses. FORWAST Deliverable n° 6-4. .
- Stadler, K., Wood, R., Bulavskaya, T., et al., 2018. EXIOBASE 3. Developing a time series of detailed environmentally extended multi-regional input-output tables. *J. Ind. Ecol.* 22, 502–515. <https://doi.org/10.1111/jiec.12715>.
- Stanhel, W.R., Cliff, R., 2015. Stocks and flows in the performance economy. *Taking Stock of Industrial Ecology*. Springer International Publishing, pp. 137–158.
- Su, B., Heshmati, A., Geng, Y., Yu, X., 2013. A review of the circular economy in China: moving from rhetoric to implementation. *J. Clean. Prod.* 42, 215–227. <https://doi.org/10.1016/j.jclepro.2012.11.020>.
- Suh, S., 2004. A note on the calculus for physical input-output analysis and its application to land appropriation of international trade activities. *Ecol. Econ.* 48, 9–17. <https://doi.org/10.1016/j.ecolecon.2003.09.003>.
- Suh, S., Weidema, B., Schmidt, J.H., Heijungs, R., 2010. Generalized make and use framework for allocation in life cycle assessment. *J. Ind. Ecol.* 14, 335–353. <https://doi.org/10.1111/j.1530-9290.2010.00235.x>.
- Tisserant, A., Pauliuk, S., Merciai, S., et al., 2017. Solid waste and the circular economy: a global analysis of waste treatment and waste footprints. *J. Ind. Ecol.* 0, 1–13. <https://doi.org/10.1111/jiec.12562>.
- Tukker, A., Bulavskaya, T., Giljum, S., et al., 2016. Environmental and resource footprints in a global context: Europe's structural deficit in resource endowments. *Glob. Environ. Change* 40, 171–181. <https://doi.org/10.1016/j.gloenvcha.2016.07.002>.
- Tukker, A., de Koning, A., Wood, R., et al., 2013. Exiopool — development and illustrative analyses of a detailed global Mr Ee Sut/lot. *Econ. Syst. Res.* 25, 50–70. <https://doi.org/10.1080/09535314.2012.761952>.
- Tukker, A., Giljum, S., Wood, R., 2018. Recent progress in assessment of resource efficiency and environmental impacts embodied in trade an introduction to this special issue. *J. Ind. Ecol.* 0, 1–13. <https://doi.org/10.1111/jiec.12736>.
- van Eygen, E., Feketeitsch, J., Laner, D., et al., 2017. Comprehensive analysis and quantification of national plastic flows: the case of Austria. *Resour. Conserv. Recycl.* 117, 183–194. <https://doi.org/10.1016/j.resconrec.2016.10.017>.
- Weisz, H., Duchin, F., 2006. Physical and monetary input-output analysis: what makes the difference? *Ecol. Econ.* 57, 534–541. <https://doi.org/10.1016/j.ecolecon.2005.05.011>.
- Weisz, H., Krausmann, F., Amann, C., et al., 2006. The physical economy of the European Union: cross-country comparison and determinants of material consumption. *Ecol. Econ.* 58, 676–698. <https://doi.org/10.1016/j.ecolecon.2005.08.016>.
- Wiedenhofer, D., Fishman, T., Lauk, C., et al., 2019. Integrating material stock dynamics into economy-wide material flow accounting: concepts, modelling, and global application for 1900–2050. *Ecol. Econ.* 156, 121–133. <https://doi.org/10.1016/j.ecolecon.2018.09.010>.
- Wiedmann, T.O., Schandl, H., Lenzen, M., et al., 2015. The material footprint of nations. *PNAS* 112, 6271–6276. <https://doi.org/10.1073/pnas.1220362110>.
- Winans, K., Kendall, A., Deng, H., 2017. The history and current applications of the circular economy concept. *Renew. Sustain. Energy Rev.* 68, 825–833. <https://doi.org/10.1016/j.rser.2016.09.123>.
- Wood, R., Stadler, K., Bulavskaya, T., et al., 2015. Global sustainability accounting—developing EXIOBASE for multi-regional footprint analysis. *Sustainability* 7, 138–163. <https://doi.org/10.3390/su7010138>.
- Wood, R., Stadler, K., Simas, M., et al., 2018. Growth in environmental footprints and environmental impacts embodied in trade: resource efficiency indicators from EXIOBASE3. *J. Ind. Ecol.* 22, 553–562. <https://doi.org/10.1111/jiec.12735>.
- World-Bank, 2019a. World Bank Open Data. <https://data.worldbank.org/>.
- World-Bank, 2019b. World Bank Country and Lending Groups. <https://datahelpdesk.worldbank.org/knowledgebase/articles/906519-world-bank-country-and-lending-groups>. (Accessed 2 May 2019).
- Yuan, Z., Bi, J., Moriguchi, Y., 2006. The Circular Economy: a new development strategy in China. *J. Ind. Ecol.* 10, 4–7. <https://doi.org/10.1038/531435a>.
- Zhu, J., Fan, C., Shi, H., Shi, L., 2018. Efforts for a circular economy in China a comprehensive review of policies. *J. Ind. Ecol.* 0, 1–9. <https://doi.org/10.1111/jiec.12754>.