



Universiteit
Leiden
The Netherlands

The pots and potters of Assyria : technology and organization of production, ceramics sequence and vessel function at Late Bronze Age Tell Sabi Abyad, Syria

Duistermaat, K.

Citation

Duistermaat, K. (2007, March 21). *The pots and potters of Assyria : technology and organization of production, ceramics sequence and vessel function at Late Bronze Age Tell Sabi Abyad, Syria*. Retrieved from <https://hdl.handle.net/1887/11416>

Version: Corrected Publisher's Version

License: [Licence agreement concerning inclusion of doctoral thesis in the Institutional Repository of the University of Leiden](#)

Downloaded from: <https://hdl.handle.net/1887/11416>

Note: To cite this publication please use the final published version (if applicable).

Fig. C.1: Kiln Q in square N11
(level 6), top plan.

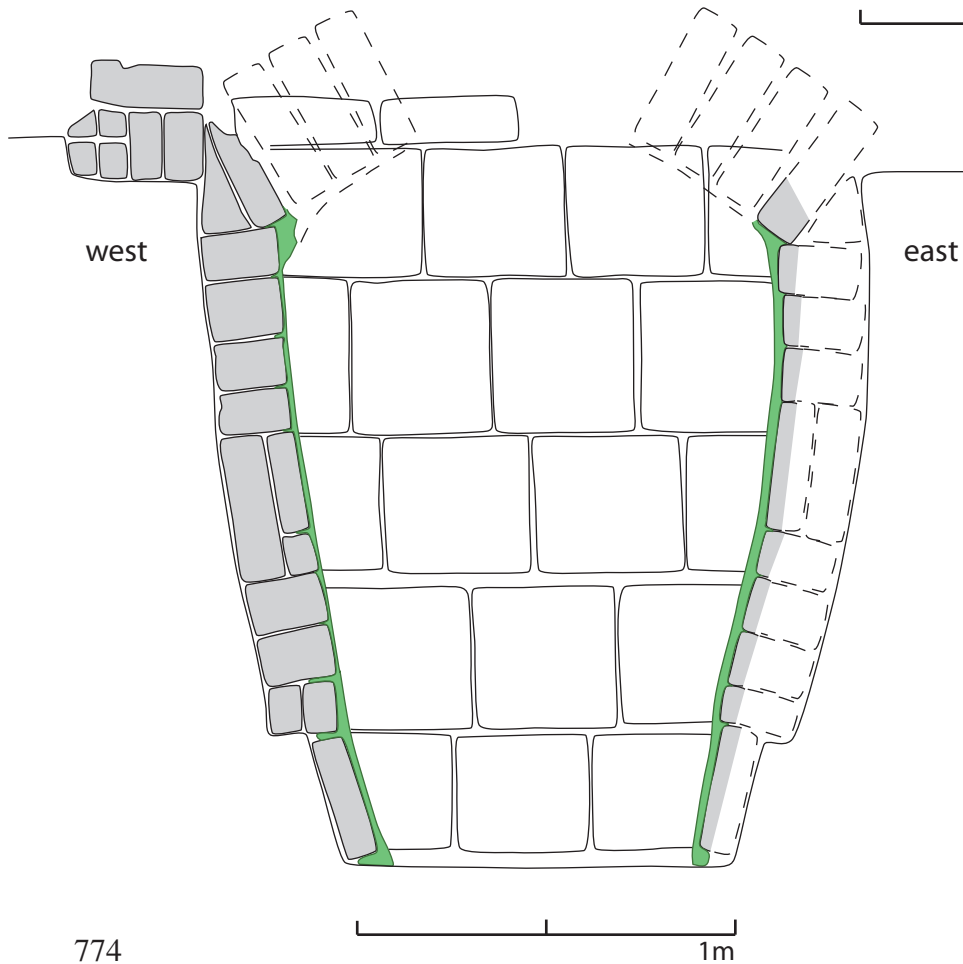
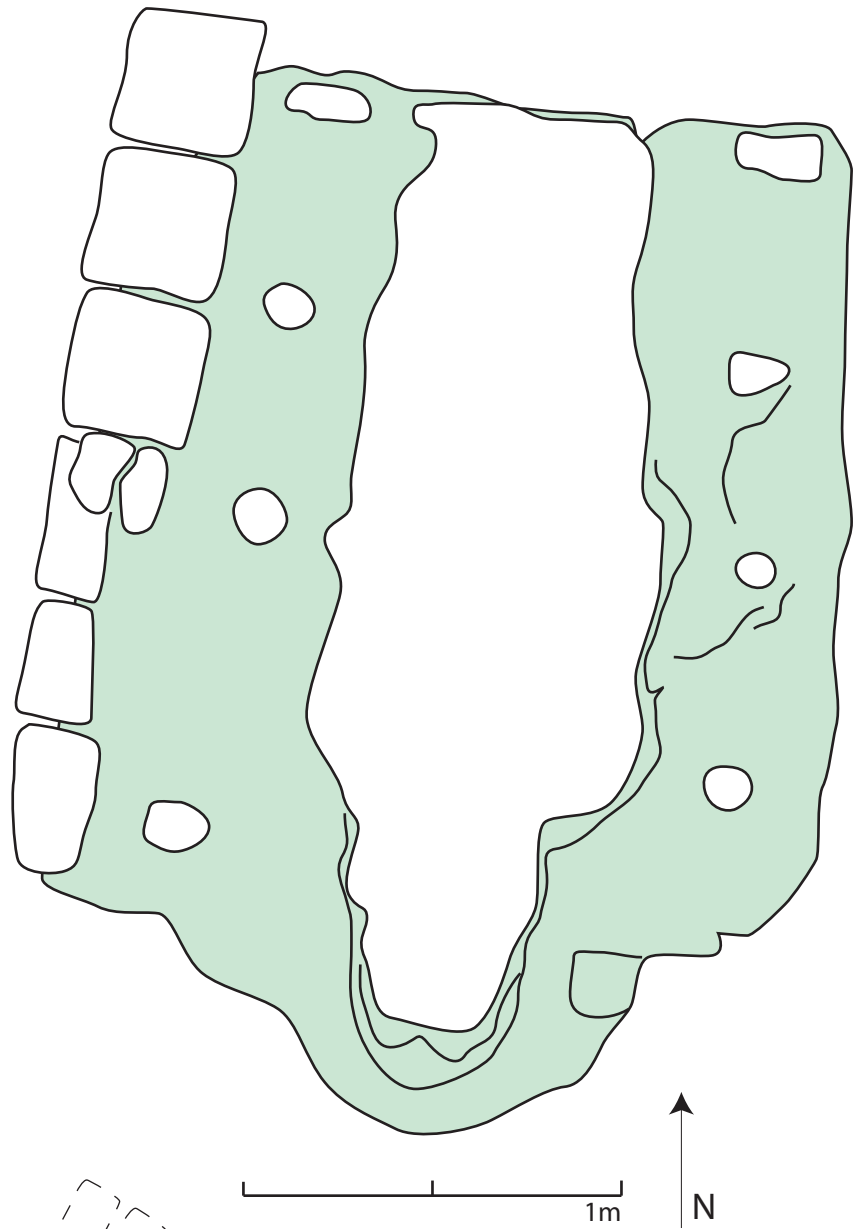

Fig. C.2: Kiln Q in square
N11, section (W-E).

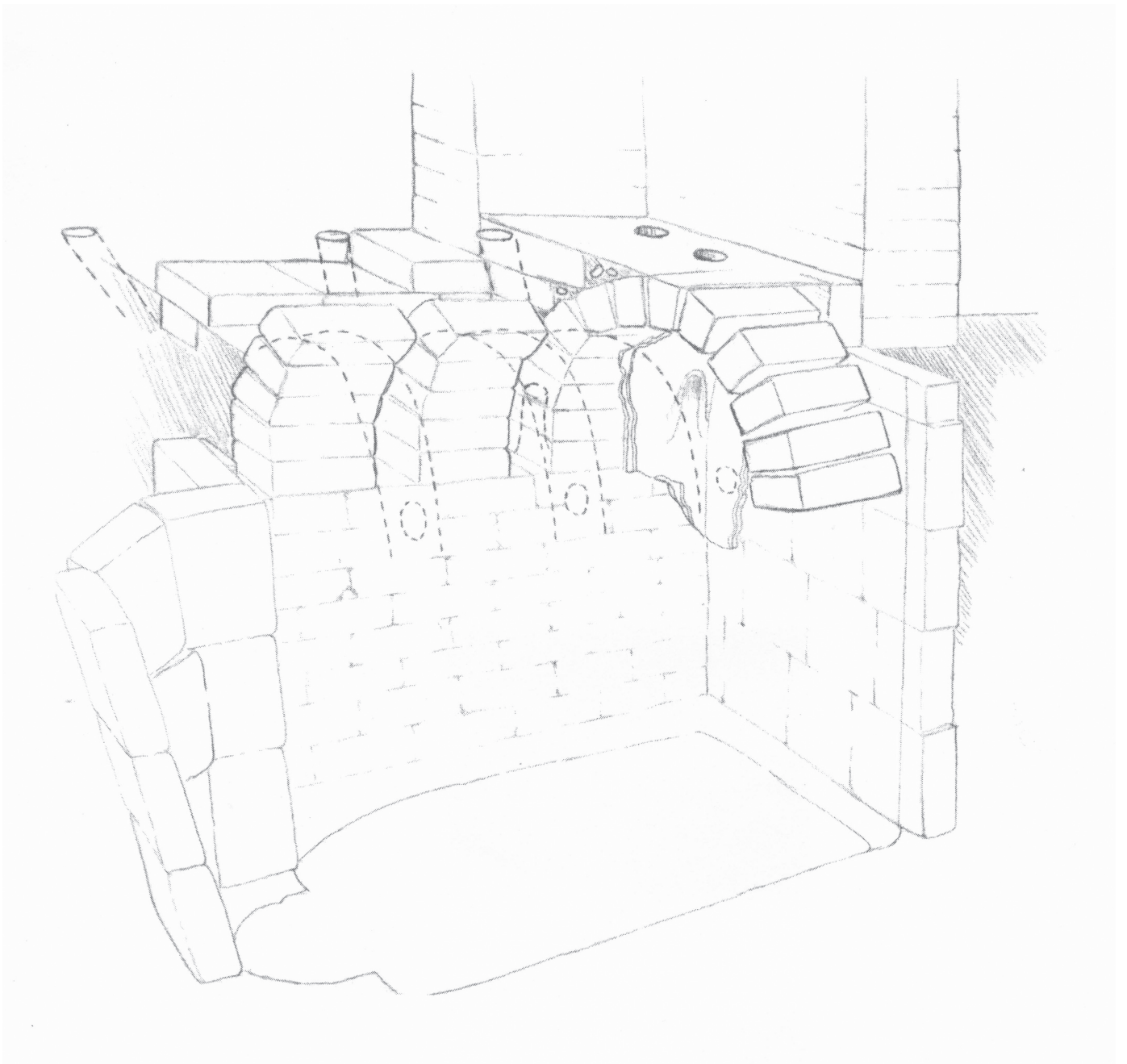

Fig. C.3: Kiln Q in square N11, reconstruction drawing.



Fig. C.4: Kiln Q in square N11. View from above, part of the pottery chamber floor and flue holes are visible.



Fig. C.5: Kiln Q during excavation, showing the depth of the fire chamber.

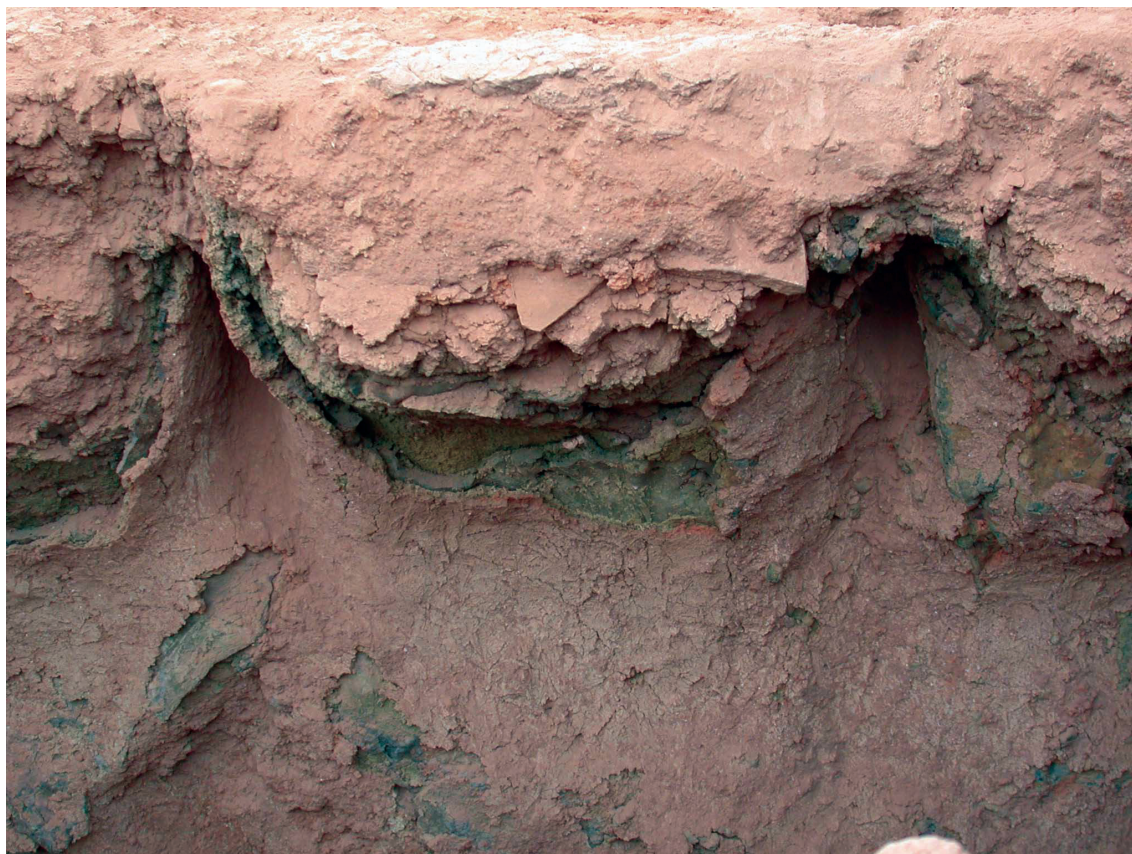

Fig. C.6: Kiln Q, the plaster on the inside of the fire chamber and the flue holes. The highly burnt bright green plaster has been re-applied a number of times. Sherds were used to fill gaps in the mud-brick arches.



Fig. C.7: Kiln Q, the burnt plaster layers on the inside of a flue hole.

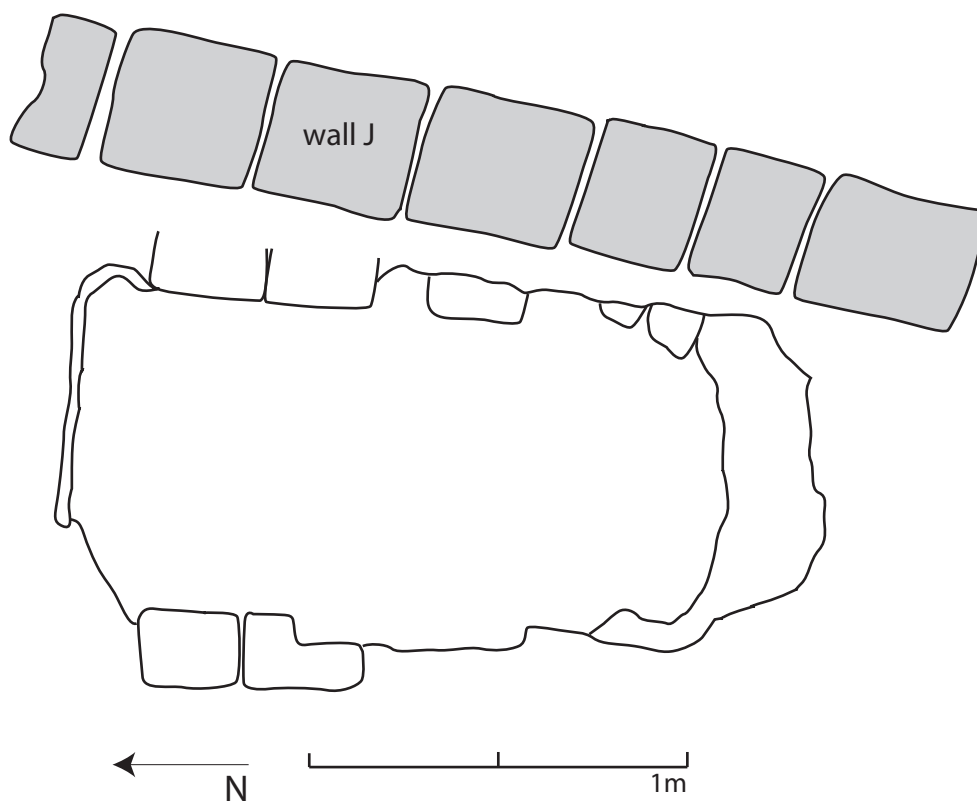

Fig. C.8: Kiln L in square N12 (level 6), sketch plan.

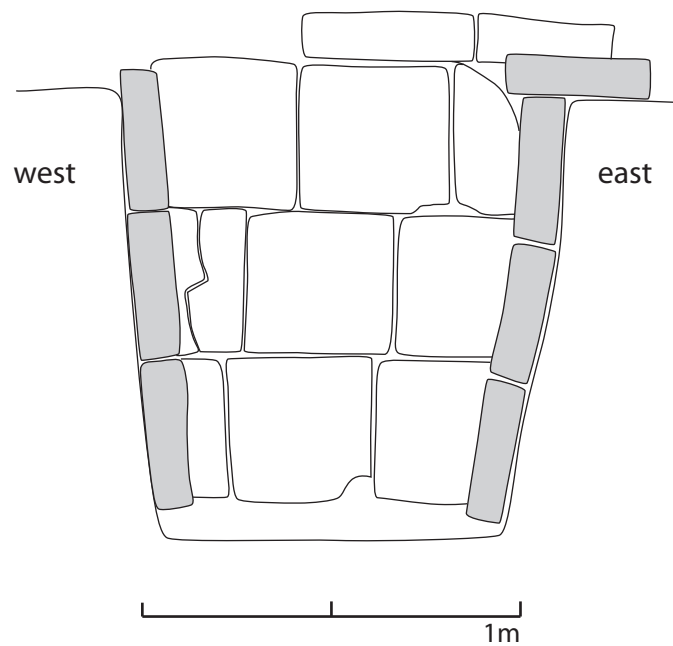

Fig. C.9: Kiln L in square N12, section (E-W).

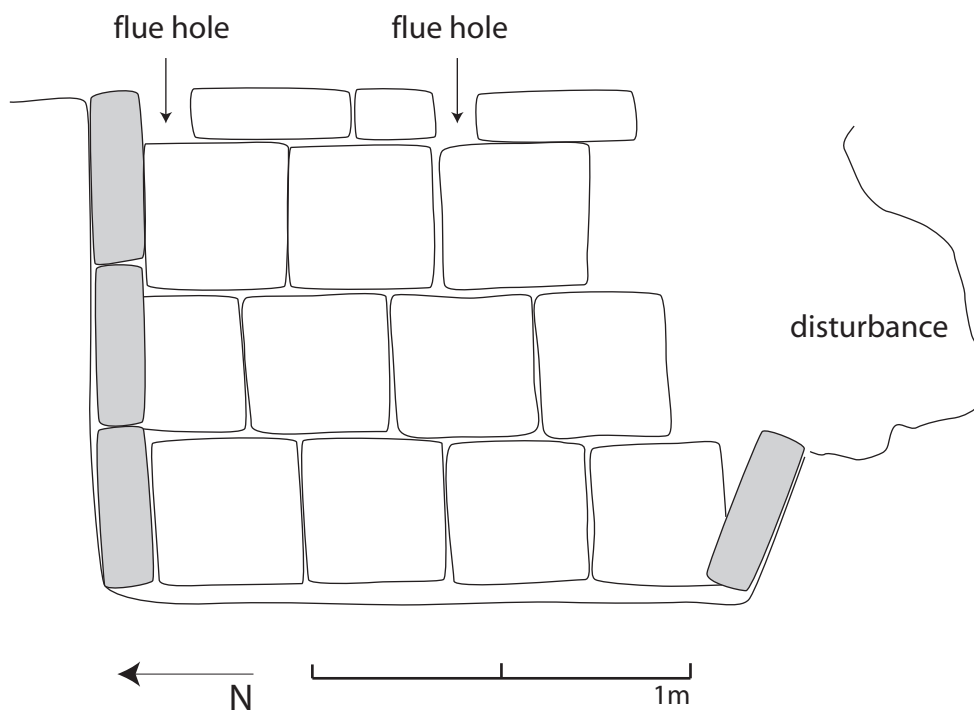

Fig. C.10: Kiln L in square N12, section (N-S).



Fig. C.11: Kiln H in square N13 (level 5?).

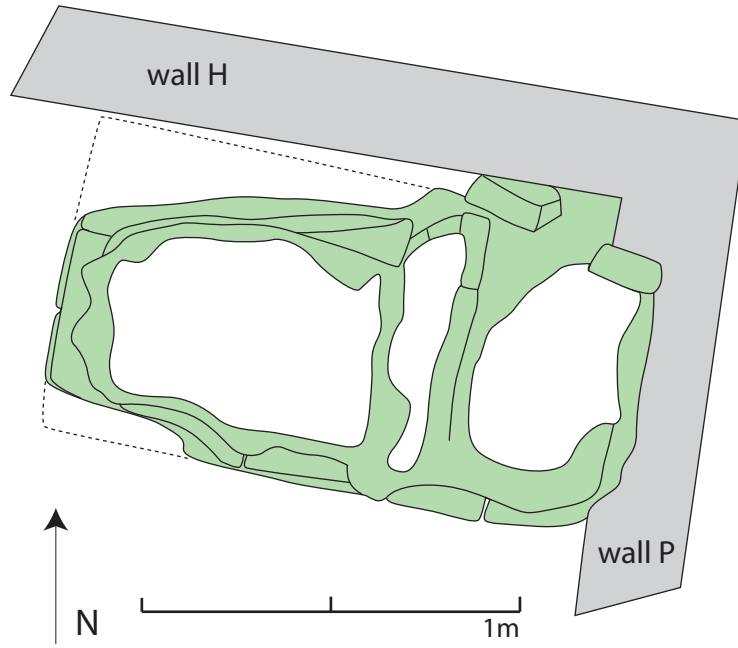

Fig. C.12: Kiln T/U in square M11 (level 5), sketch plan.

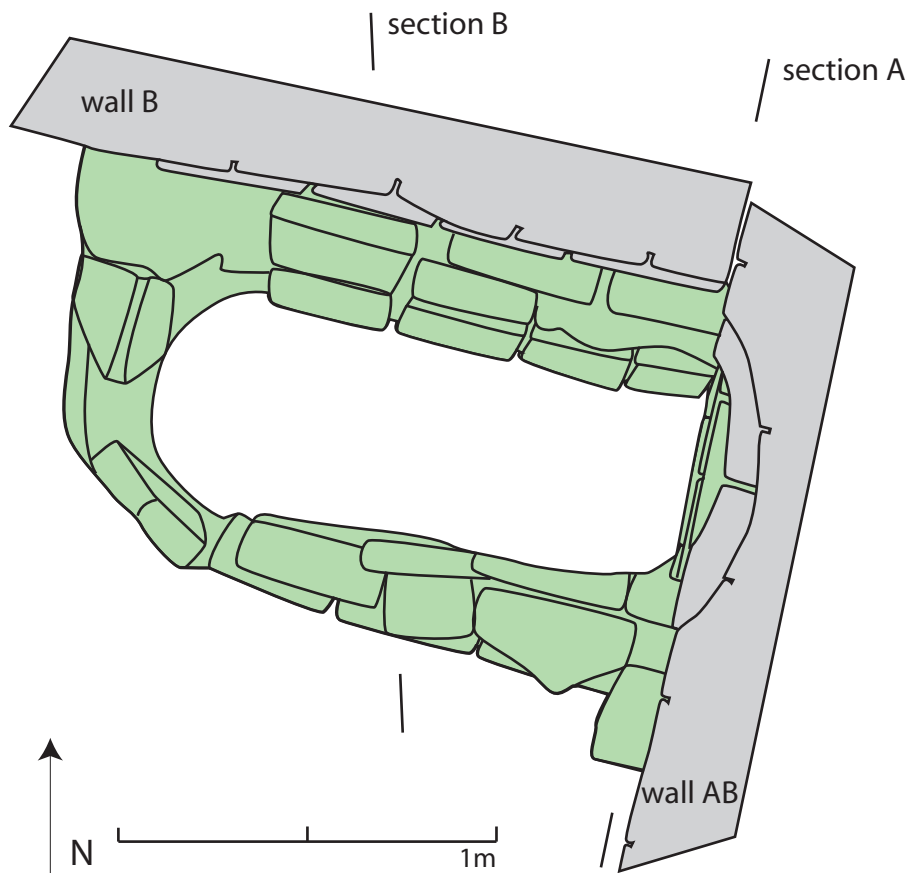

Fig. C.13: Kiln H/AE in square H8 (level 5), top plan.

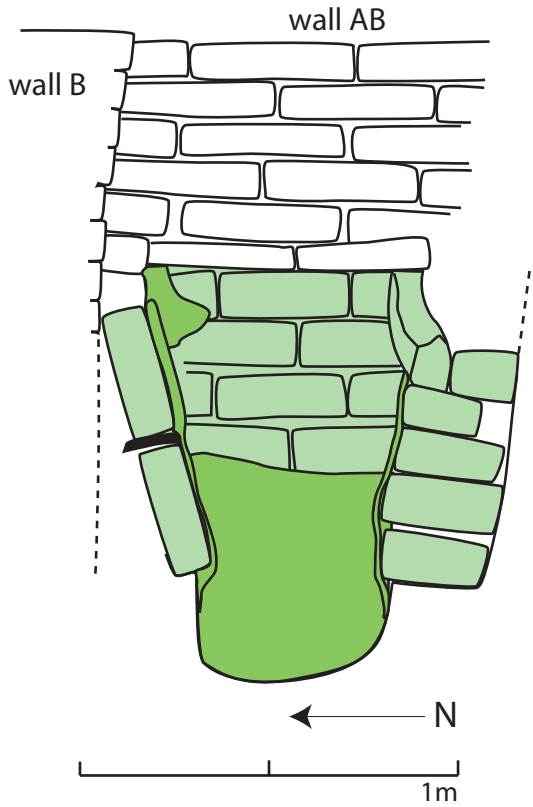

Fig. C.14: Kiln H/AE in square H8, section A.

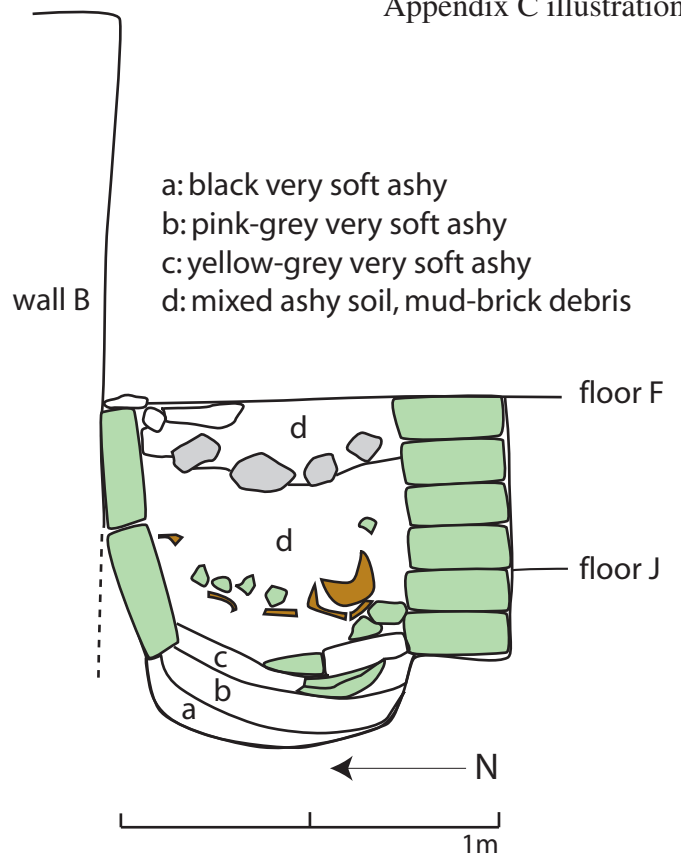

Fig. C.15: Kiln H/AE in square H8, section B: section through the kiln fill.



Fig. C.16: Kiln H/AE, top view (section B is at the bottom of the picture).



Fig. C.17: Kiln H/AE, section B.

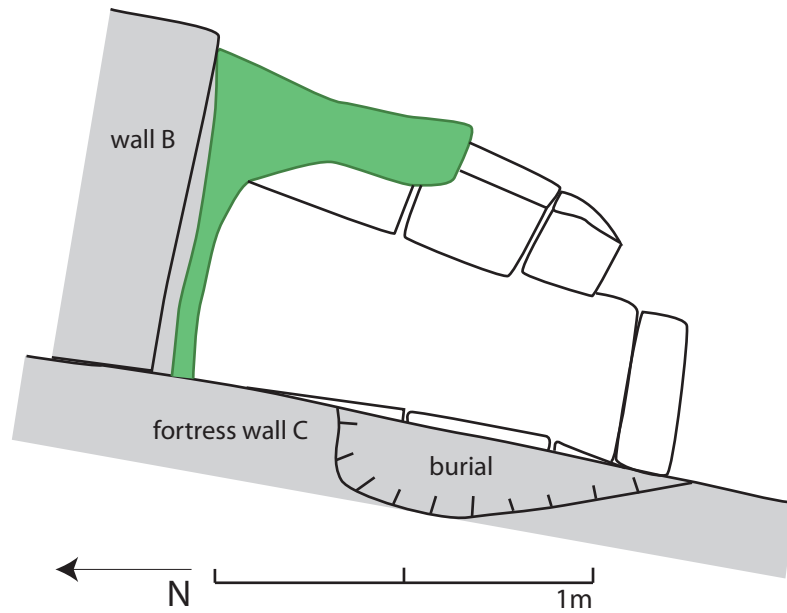

Fig. C.18: Kiln I in square H8 (level 5), top plan.

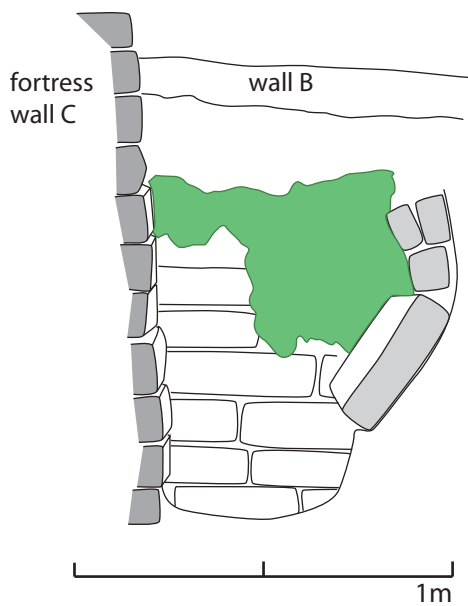

Fig. C.19: Kiln I in square H8, section W-E.



Fig. C.20: Kiln I in square H8, view to the north. At the left of the picture, the cut made by the burial can be clearly seen.

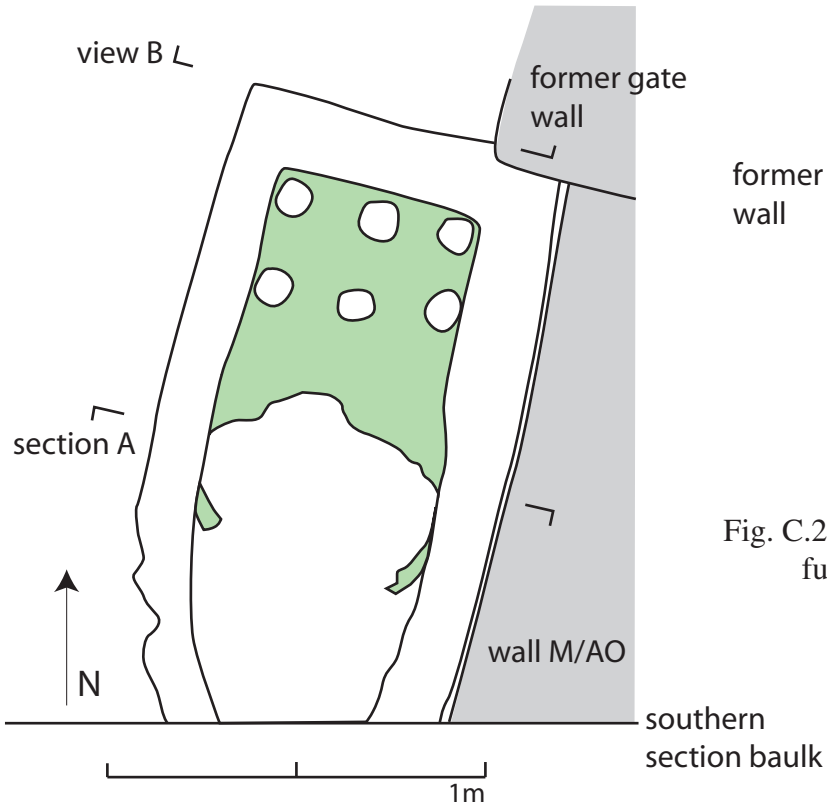

Fig. C.21: Kiln CJ/V in square K8 (level 5), top plan.

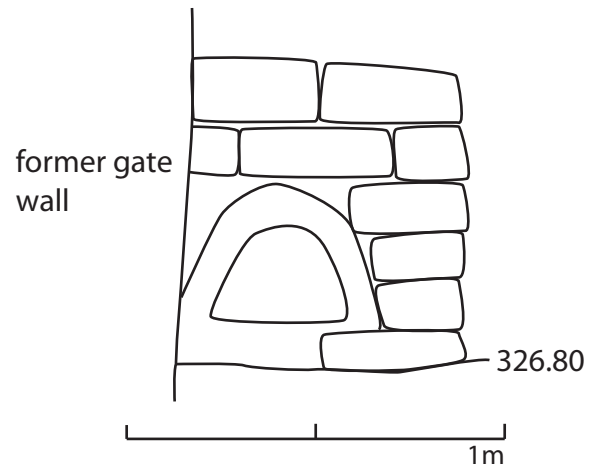

Fig. C.23: Kiln CJ/V in square K8, front view of fueling hole (view B, looking south)

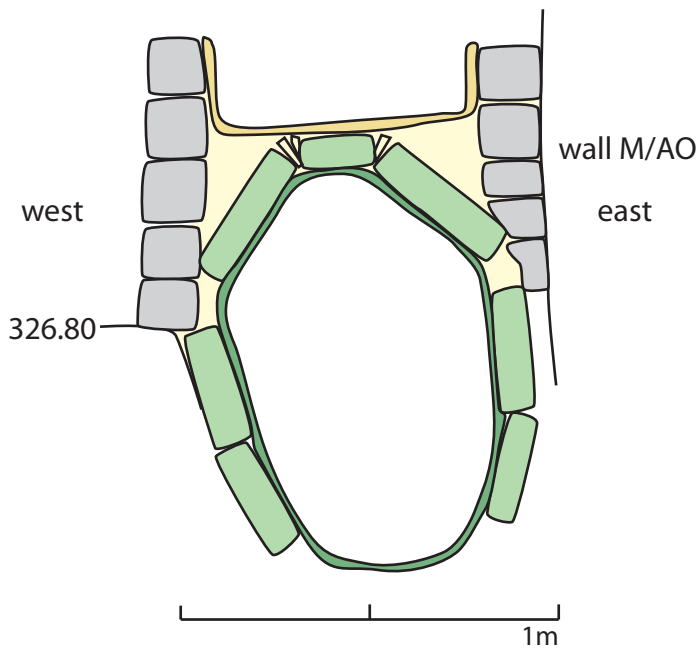

Fig. C.22: Kiln CJ/V in square K8, section E-W (A).



Fig. C.24: Kiln CJ/V in square K8 (level 5), view towards the east.



Fig. C.25: Kiln CJ/V in square K8, view from the top. The north is on the right of the picture.

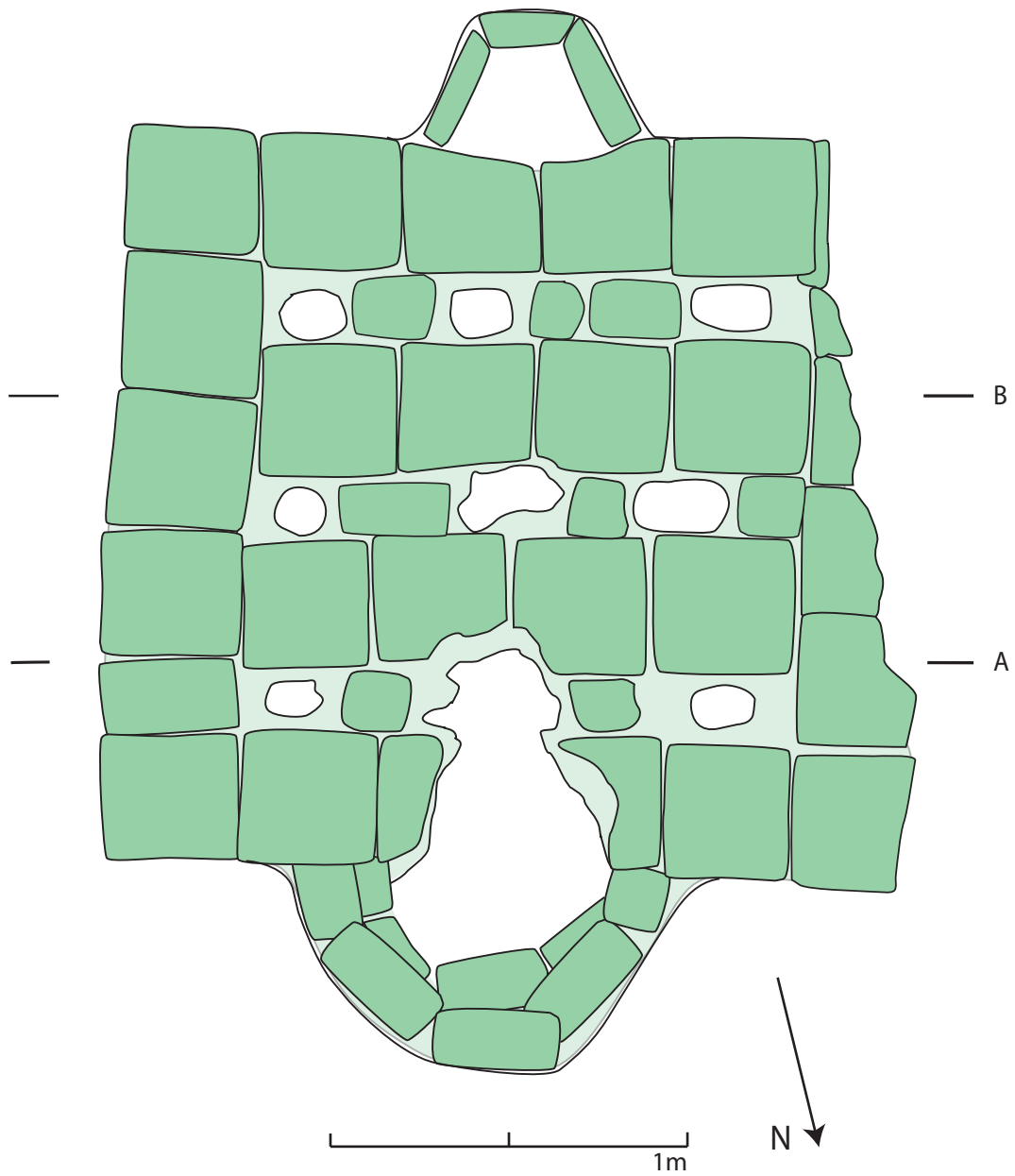

Fig. C.26: Kiln K in square J7 (level 4), schematical top plan.



Fig. C.27: Kiln K in square J7, view from above.

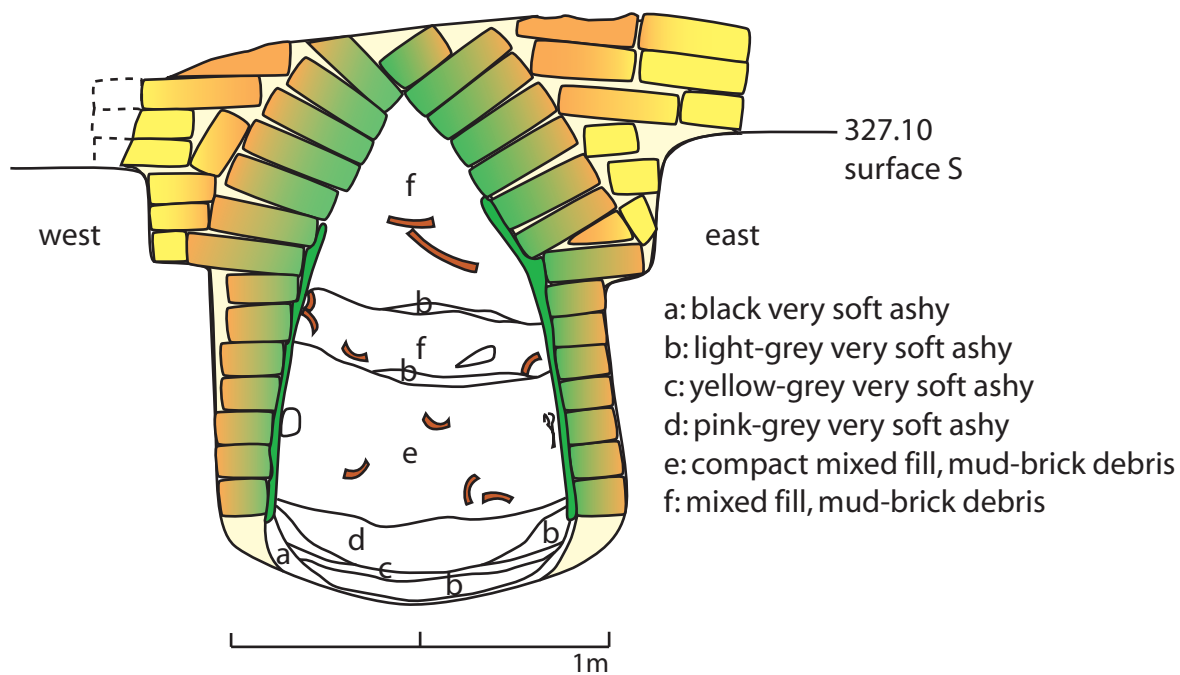

Fig. C.28: Kiln K in square J7, section B, looking north.

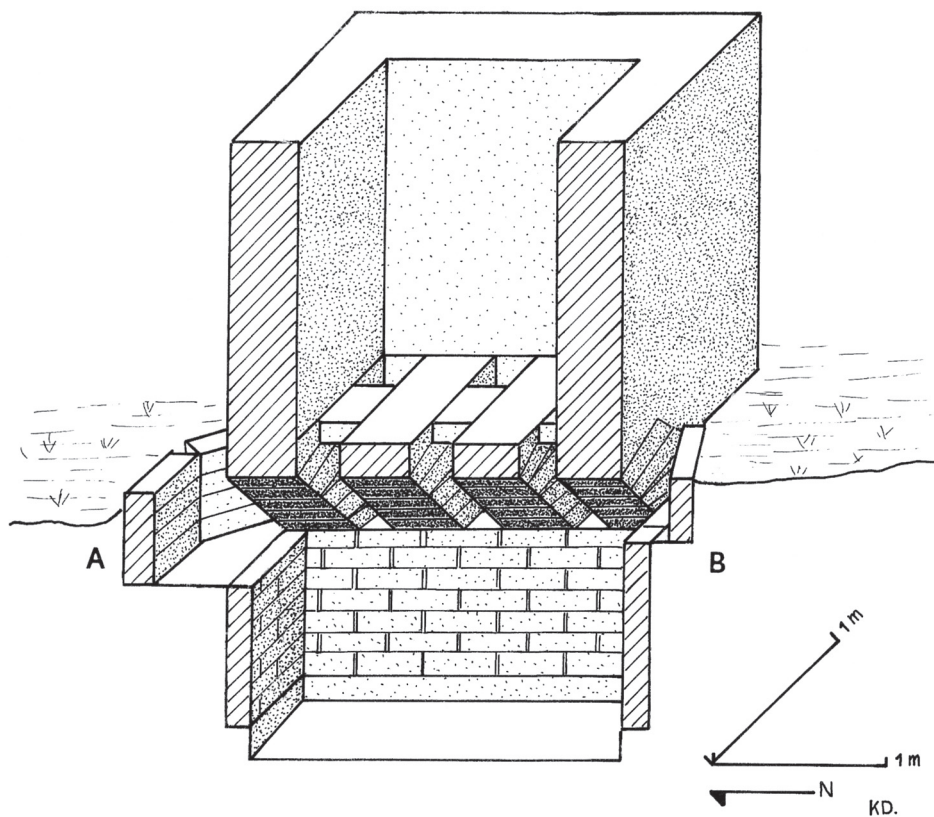

Fig. C.29: Kiln K in square J7, reconstruction drawing.



Fig. C.30: Kiln K in square J7, section B, looking north.



Fig. C.31: Kiln K in square J7, section A, looking south.