



Universiteit
Leiden
The Netherlands

The pots and potters of Assyria : technology and organization of production, ceramics sequence and vessel function at Late Bronze Age Tell Sabi Abyad, Syria

Duistermaat, K.

Citation

Duistermaat, K. (2007, March 21). *The pots and potters of Assyria : technology and organization of production, ceramics sequence and vessel function at Late Bronze Age Tell Sabi Abyad, Syria*. Retrieved from <https://hdl.handle.net/1887/11416>

Version: Corrected Publisher's Version

License: [Licence agreement concerning inclusion of doctoral thesis in the Institutional Repository of the University of Leiden](#)

Downloaded from: <https://hdl.handle.net/1887/11416>

Note: To cite this publication please use the final published version (if applicable).

figure no.	level	square	locus	lot	no.	technology	ware group	surface	colour inside	colour outside	colour fracture	decoration	special tr.	rim diameter	base diameter	rim type	base type	capacity (l)	comparisons
IV.114.a	3	19	23	059	P96-28	A	J	2	6	3	6	1	12	90	29	111a	731		
IV.114.b	3	19	55	120	P98-25	A	I	2	2	2	3	1	42	95	33	111a	731		
IV.114.c	3	top	1049	053	P92-59	A	H	2	7	7	1	4	85	30	111a	731			
IV.114.d	3	110	4	007	1	A	J	2	2	2	2	1	12	90	38	111a	731		Sheikh Hamad MA III (Pfälzner 1995: Taf. 146a).
IV.114.e	3	18	46	138	P98-20	A	J	2	4	4	4	1	12	90	38	111a	731		
IV.114.f	3	K10	19	030	P91-112ii	A	H	2	3	3	1	1	85	40	111a	731			
IV.114.g	-	19	54	117	P96-387	A	B	2	4	4	2	1	0	70	30	111a	731		
IV.114.h	-	111	28	065	P96-492	A	I	2	3	3	3	1	0	90	60	111a	731		
IV.114.i	3	K10	19	030	P91-83iv	A	H	2	1	1	1	52	140	45	111b	731			Sheikh Hamad MA IIc (Pfälzner 1995: Taf. 106d).
IV.114.j	3	110	16	042	1	A	I	2	4	4	4	1	0	140	111b	-			
IV.114.k	3	110	14	024	6	A	I	2	2	2	2	1	0	140	111b	-			
IV.114.l	3	K10	19	030	38	A	I	2	2	2	2	1	0	160	111b	731			Sheikh Hamad MA III (Pfälzner 1995: Taf. 137c, not very close).
IV.114.m	3	top	1049	052	P92-58	A	H	2	3	3	3	1	51	200	65	111c	731		
IV.114.n	3	110	14	024	12	A	J	2	2	2	2	1	0	200	111c	-			
IV.114.o	3	110	14	021	28	A	I	2	2	2	2	1	0	250	111c	-			
IV.114.p	3	110	4	010	1	A	I	2	4	4	4	1	0	180	111c	-			
IV.114.q	3	110	15	025	3	A	I	2	2	2	3	1	0	210	111c	-			
IV.114.r	3	110	16	042	17	A	I	2	7	7	7	1	0	200	111c	-			
IV.114.s	3	110	1	014	7	A	I	2	3	3	3	1	0	200	111c	-			Sheikh Hamad MA III (Pfälzner 1995: Taf. 138d).
IV.114.t	3	110	14	021	5	A	I	2	7	7	7	1	0	210	111c	-			
IV.114.u	-	J10	43	099	2	A	I	2	3	3	3	1	0	210	111c	-			
IV.114.v	3	J10	2	016	P93-228	A	I	2	2	2	3	1	0	140	51	112a	731	0,40	Tell Taban level 6, level 9 (Ohnuma et al. 1998: fig. 10 no. 23, Ohnuma and Numoto 2001: fig. 7 no. 10)
IV.114.w	3	J10	2	016	P93-230	A	I	2	2	2	2	1	9	148	45	112a	731	0,40	
IV.114.x	3	19	53	112	P98-24	A	I	2	3	3	3	1	0	180	68	112b	731		
IV.114.y	3	L11	22	026	4	A	I	2	4	4	4	1	0	190	112b	-			
IV.114.z	3	J10	17	031	10	A	I	2	7	7	7	1	55	230	112b	-			(rim deformed before firing) Tell Taban level 8 (Ohnuma et al. 2000: fig. 8 no 20).
IV.114.aa	-	K8	110	228	P97-93	A	I	2	3	3	3	1	22	200	70	112b	731		
IV.114.ab	3	J10	3	013	13	B	J	2	4	4	6	1	0	200	113	-			
IV.114.ac	3	J10	3	008	P93-158	B	I	2	4	4	6	1	9	220	78	113	741	1,60	
IV.114.ad	3	110	16	042	2	B	J	2	4	4	4	1	0	230	113	-			Sheikh Hamad MA IIc (Pfälzner 1995: Taf. 107b).
IV.114.ae	3	J10	3	013	22	B	J	4	4	4	6	1	0	240	113	-			
IV.114.af	3	L9	17	065	2	B	I	2	4	4	4	1	0	250	113	-			
IV.114.ag	3	J10	3	013	23	B	I	2	2	2	2	1	0	270	113	-			

Level 3

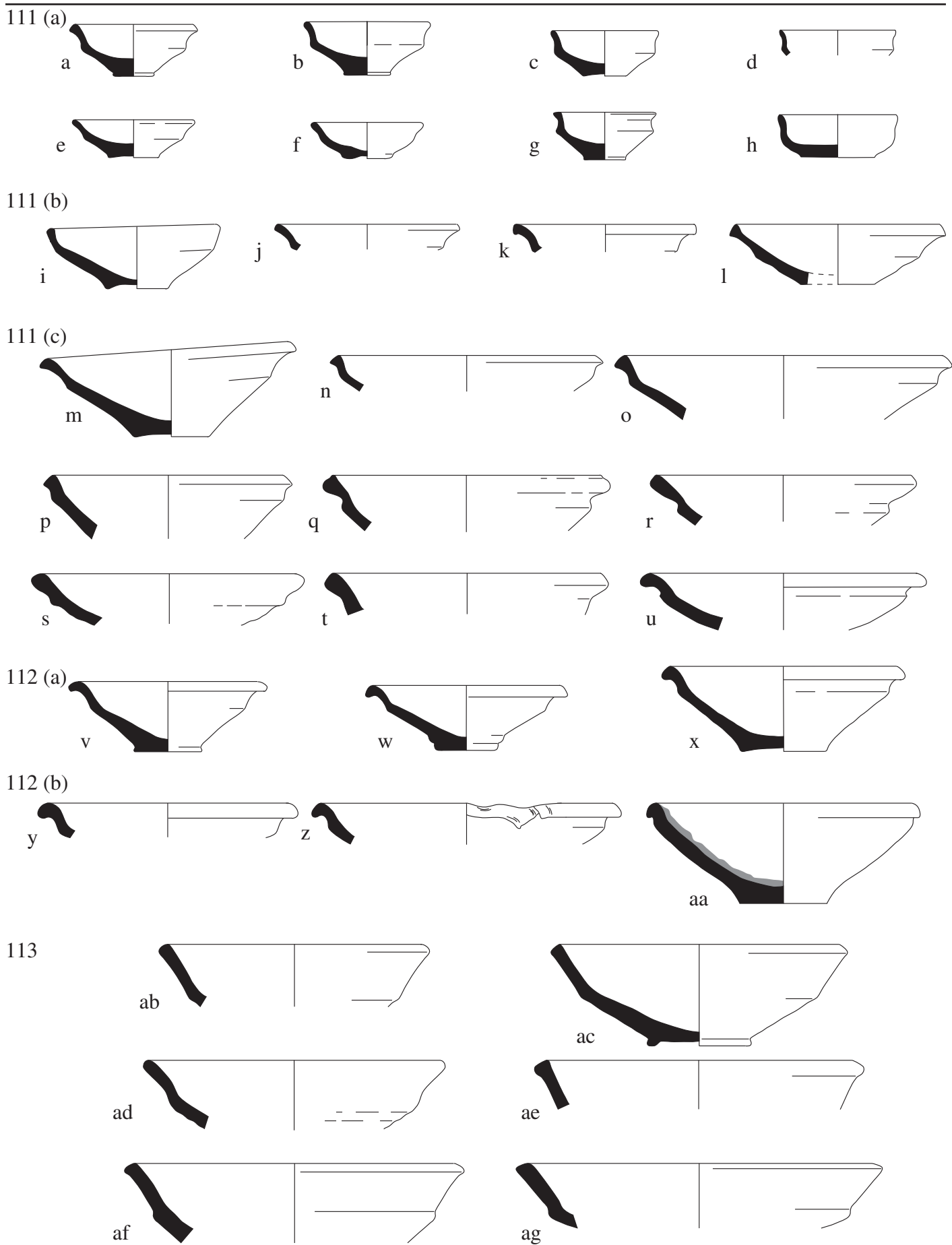

scale 1:4

figure no.	level	square	locus	lot	no.	technology	ware group	surface	colour inside	colour outside	colour fracture	decoration	special tr.	rim diameter	base diameter	rim type	base type	capacity (l.)	comparisons
IV.115.a	3	J9	57	124	P98-26	B	I	2	4	4	6	1	9	260	93	113	741	2,53	
IV.115.b	3	J10	3	008	P93-160	B	C	2	3	3	3	1	0	260	97	113	741	2,96	
IV.115.c	3	I10	1	014	5	B	I	2	3	3	3	31	0	250		113	-		Tell Brak, HHI (Oates et al. 1997: fig. 181 no. 27).
IV.115.d	3	J10	14	027	1	B	I	2	4	4	6	31	0	340		113	-		Sheikh Hamad MA IIc (Pätzner 1995: Taf. 104e).
IV.115.e	3	K10	19	030	53	B	H	2	3	3	3	1	0	260	45	119?	731		Sheikh Hamad MA IIc, MA III (Pätzner 1995: Taf. 137c, Taf. 102a) - Sheikh Hassan (Euphrates) (Schneider 1999: abb. 6 no. 7, 1) - Tell al-Rimah level C1 (Postgate et al. 1997: pl. 55 no. 486, not very close).
IV.115.f	3	K10	19	030	P91-83viii	A	H	2	2	2	6	1	0	140		123	-		
IV.115.g	3	L9	17	038	3	A	A	2	3	3		1	0	240		1215	-		
IV.115.h	3	J8	59	152	P98-125	B	I	2	3	3	7	1	21	250	80	131	731	1,94	
IV.115.i	3	I10	14	023	7	B	I	2	3	3	6	1	0	230		131	-		
IV.115.j	3	I10	14	023	12	B	I	2	3	3	6	1	0	250		131	-		
IV.115.k	3	I10	24	044	1	B	M	2	2	2	2	1	1,2	360		131	-		
IV.115.l	3	L9	17	067	1	B	I	2	4	4	4	1	0	390		131	-		
IV.115.m	3	J10	3	015	3	B	I	2	2	2	3	1	0	350		131	-		
IV.115.n	3	I10	1	012	14	B	I	2	3	3	3	1	0	320		131?	-		
IV.115.o	3	I10	18	031	1	I	2	3	3	3	3	1	0	380		133	-		Tell Brak, HHI (Oates et al. 1997: fig. 181 no. 12).
IV.115.p	3/4	K9	38	073	9	J	2	4	4	4	1	0	290		133	-			
IV.115.q	3	I10	1	014	9	I	2	3	3	3	3	1	0	300		136	-		
IV.115.r	3	I10	16	036	22	I	2	2	2	2	2	1	0	340		136	-		
IV.115.s	3/5	I11	1	003	1	B	2	2	3	3	3	1	9	320		136?	-		

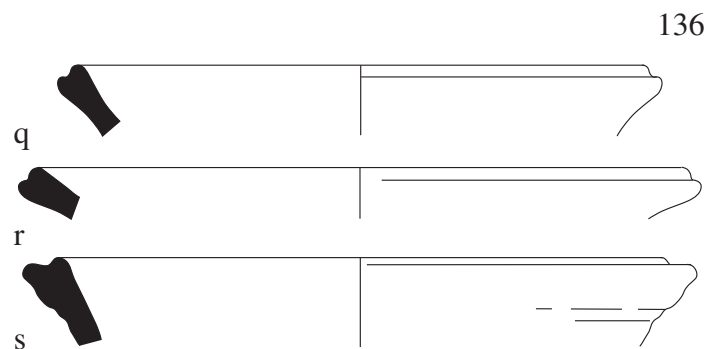

113
119

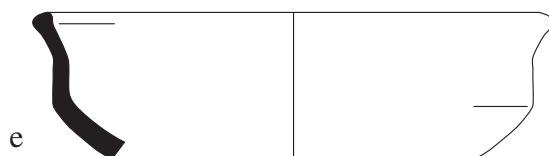
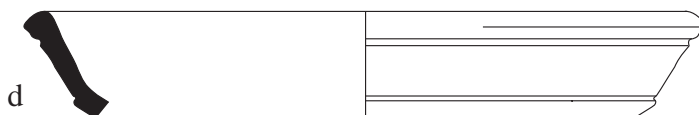
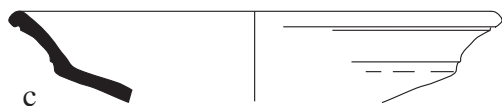
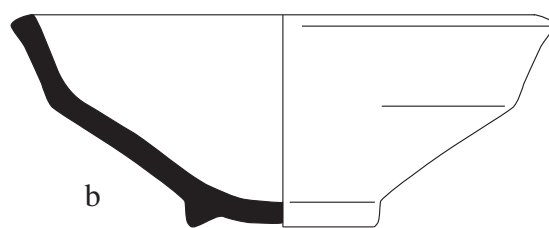
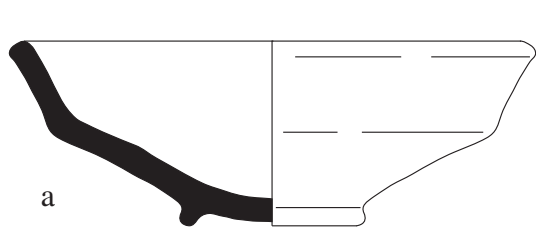

123
1215

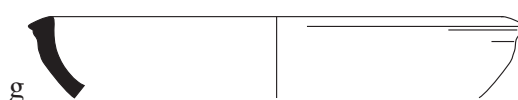

131

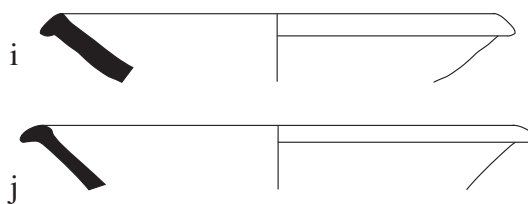
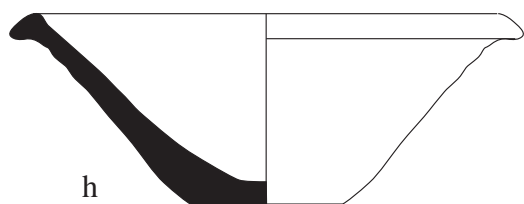

133

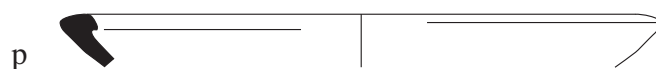
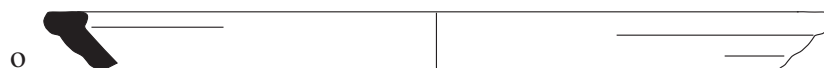

scale 1:4

figure no.	level	square	locus	lot	no.	technology	ware group	surface	colour inside	colour outside	colour fracture	decoration	special tr.	rim diameter	rim type	comparisons
IV.116.a	3	L9	17	053	3	B	J	2	8	8	8	31	0	340	141	
IV.116.b	3	I10	1	012	7	B	I	2	7	7	7	1	0	350	142	
IV.116.c	3	K10	19	030	94	B	H	5	2	2		1	0	390	143	
IV.116.d	3	L9	17	046	3		H	2	7	7	7	73	0	> 400	145	
IV.116.e	3	J10	3	015	6	B	I	2				1	0	260	211a	Sheikh Hamad MA III (Pfälzner 1995: Taf. 147).
IV.116.f	3	L9	29	021	1		I	2	3	3	3	1	0	310	211	Tille Höyük I-III (Blaylock 1999: fig. 2 no. 8).
IV.116.g	3	J10	17	031	12	E	D	2	8	8	8	1	0	230	212a	
IV.116.h	3	I10	3	011	3	E	E	2	8	8	6	1	0	> 400	212b	
IV.116.i	3	K10	19	030	102	B	K	2	8	8		31	1	401	212b	

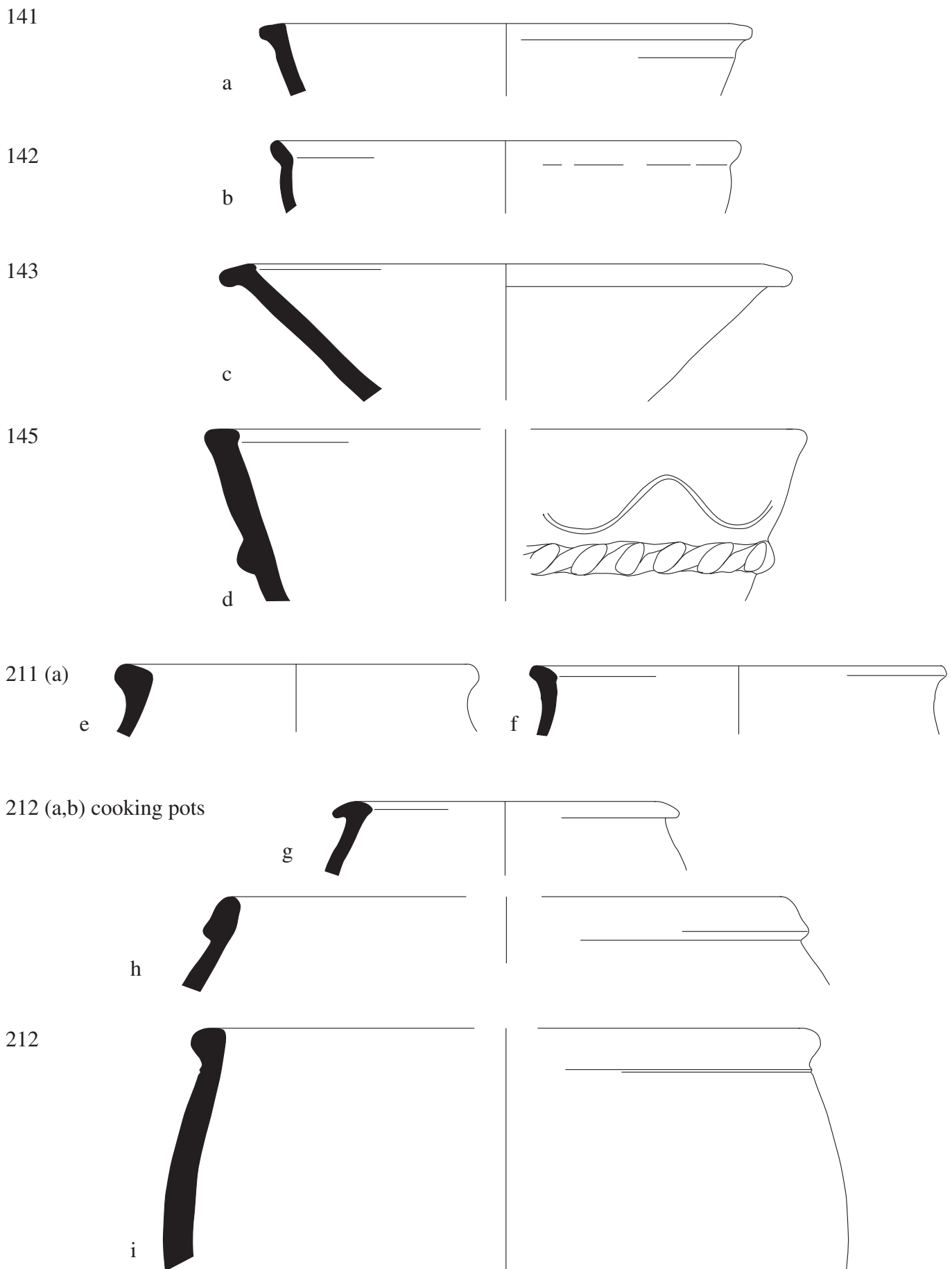

scale 1:4

figure no.	level	square	locus	lot	no.	technology	ware group	surface	colour inside	colour outside	colour fracture	decoration	special tr.	rim diameter	base diameter	rim type	base type	capacity (l.)	comparisons
IV.117.a	3	L11	22	039	4	B	I	2	2	2	3	1	0	250		221a	-		
IV.117.b	3	K10	19	030	72	B	I	2	2	2	3	1	0	220		221a	-		
IV.117.c	3	L11	22	039	2	B	I	2	2	2	3	1	0	290		221a	-		
IV.117.d	3	L9	17	065	1	B	I	2	3	3	3	1	0	340		221a	-		
IV.117.e	3	J10	3	015	5	E	C	2	3	3	3	1	0	400	>	226	-		
IV.117.f	3	K10	19	030	6	I	I	2	7	7	7	1	0	320		231	-		
IV.117.g	3	J10	3	013	6	I	I	2	4	4	3	1	0	110		311	-		
IV.117.h	3	J10	2	016	1	B	H	2	2	2	2	1	0	100		312	-		
IV.117.i	3	I10	18	030	P93-134ii	B	I	2	3	3	2	1	0	116	56	311b	731	5,75	(wall is damaged on the inside)
IV.117.j	3	K10	19	030	P91-85	B	H	5	1	1	7	31	5	120	90	312 (m)	731	7,60	Sheikh Hamad MA IIc (Pfalzner 1995: Taf. 119c).

221 (a)

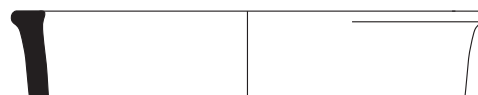
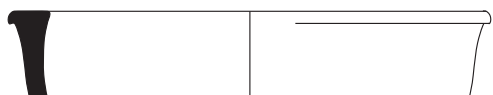

a

b



c

d

226



e

231

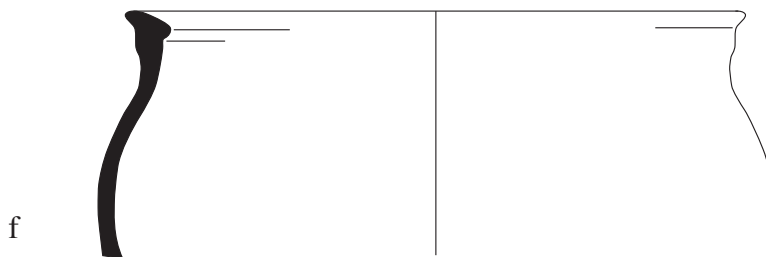

f

311 (b)

312



g

h

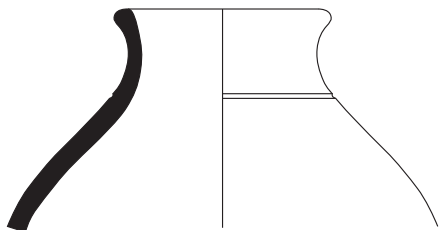

i

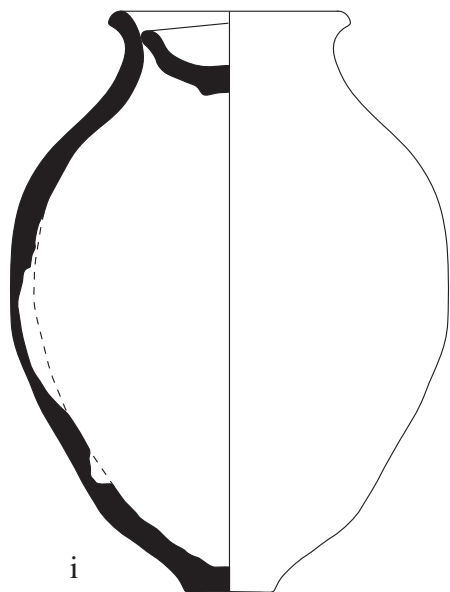

j

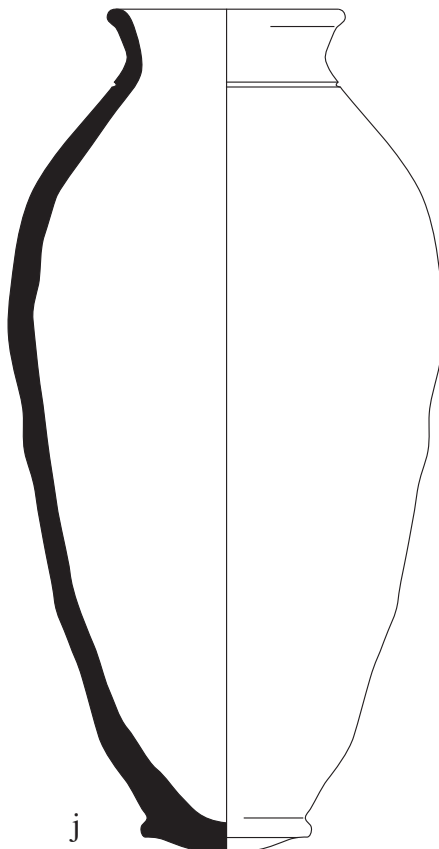

scale 1:4

figure no.	level	square	locus	lot	no.	technology	ware group	surface	colour inside	colour outside	colour fracture	decoration	special tr.	rim diameter	base diameter	rim type	base type	capacity (l.)	comparisons
IV.118.a	3	J9	57	130	P98-42		I	2	7	7	7	1	0	90	34	313 (s)	721	1,00	Sheikh Hamad MA IIc (Pfälzner 1995: Taf. 119g).
IV.118.b	3	J10	3	013	11		H	2	4	4	6	1	0	100	313	313	-		Sheikh Hamad MA III (Pfälzner 1995: Taf. 150d).
IV.118.c	3	J10	3	008	3		I	2	2	2	2	1	0	110	313	313	-		Sheikh Hamad MA IIb, III (Pfälzner 1995: Taf. 123f, Taf. 156d).
IV.118.d	3	L9	17	038	2		N	2	8	8	8	1	0	100	313	313	-		Sheikh Hamad MA III (Pfälzner 1995: Taf. 150e).
IV.118.e	3	J10	12	014	11		I	2	2	2	2	1	0	100	314?	314?	-		Giricano Hoyuk (Schachner 2002: abb. 22f).
IV.118.f	3	J10	12	019	1		C	1	2	2	2	1	0	100	314?	314?	-		Tell Brak HHI (Oates et al. 1997: fig. 182 no. 32, not very close).
IV.118.g	3	J10	2	016	5		I	2	2	2	3	1	0	120	315	315	-		
IV.118.h	3	J10	18	030	P93-133i		B	1	2	3	3	1	0	120	76	315 (m)	741		Giricano Hoyuk (Schachner 2002: abb. 25a, b).
IV.118.i	3	J10	3	008	8		C	1	2	6	3	6	1	150	321	321	-		
IV.118.j	3	J10	2	016	11		C	1	2	8	6	1	0	150	321	321	-		
IV.118.k	3	J10	16	042	10		C	H	2	7	7	1	0	150	321	321	-		
IV.118.l	3	J10	10	023	1		C	1	2	3	3	1	0	170	321	321	-		
IV.118.m	3	J10	14	023	10		C	1	2	3	3	1	0	140	321	321	-		
IV.118.n	3	J10	3	011	4		C	K	2	3	3	1	0	130	321	321	-		
IV.118.o	3	J10	15	025	4		C	1	2	3	3	1	0	170	321	321	-		
IV.118.p	3	L9	17	065	3		C	1	2	3	3	1	0	150	321	321	-		
IV.118.q	3	J10	3	011	2		C	H	2	7	7	1	0	140	321	321	-		
IV.118.r	3	J10	2	016	9		C	1	2	3	3	1	0	140	321	321	-		Sheikh Hamad MA IIc (Pfälzner 1995: Taf. 122c)
IV.118.s	3	J10	3	011	1		I	2	3	3	6	1	0	180	321	321	-		Sheikh Hamad MA III (Pfälzner 1995: Taf. 155f?) - Tell Taban level 8 (Ohnuma and Numoto 2001: fig. 9 no. 38?).
IV.118.t	3	J10	3	011	7		C	J	2	3	3	1	0	150	321	321	-		
IV.118.u	3	L11	22	039	6		C	1	2	7	7	1	0	160	321	321	-		
IV.118.v	3	L9	17	065	4		B	1	2	4	6	1	0	210	321?	321?	-		
IV.118.w	3	top	1049	052	2		C	1	2	4	4	6	1	170	322	322	-		
IV.118.x	3	L9	17	032	1		C	1	2	8	6	1	0	140	322	322	-		
IV.118.y	3	K10	19	030	8		C	1	2	2	2	1	0	130	322	322	-		Sheikh Hamad MA IIc (Pfälzner 1995: Taf. 120d).
IV.118.z	3	K10	19	033	9		C	1	2	2	2	31	0	170	322	322	-		
IV.118.aa	3	J10	3	013	14		C	1	2	3	6	1	0	140	323	323	-		Sheikh Hamad MA III (Pfälzner 1995: Taf. 151c).
IV.118.ab	3	J10	22	037	3		C	H	2	8	6	1	12	120	322	322	-		Sheikh Hamad MA III (Pfälzner 1995: Taf. 155b).
IV.118.ac	3	J10	1	012	6		C	1	2	3	3	1	0	150	323	323	-		

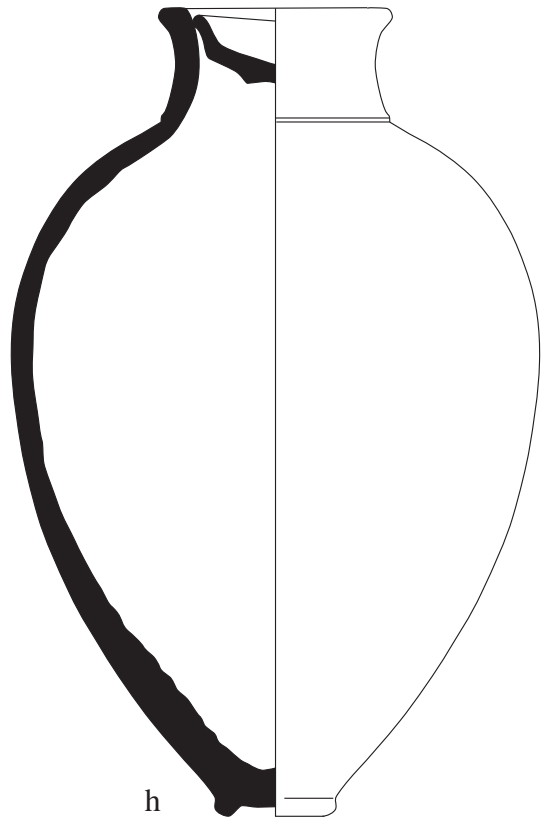

313
314
315

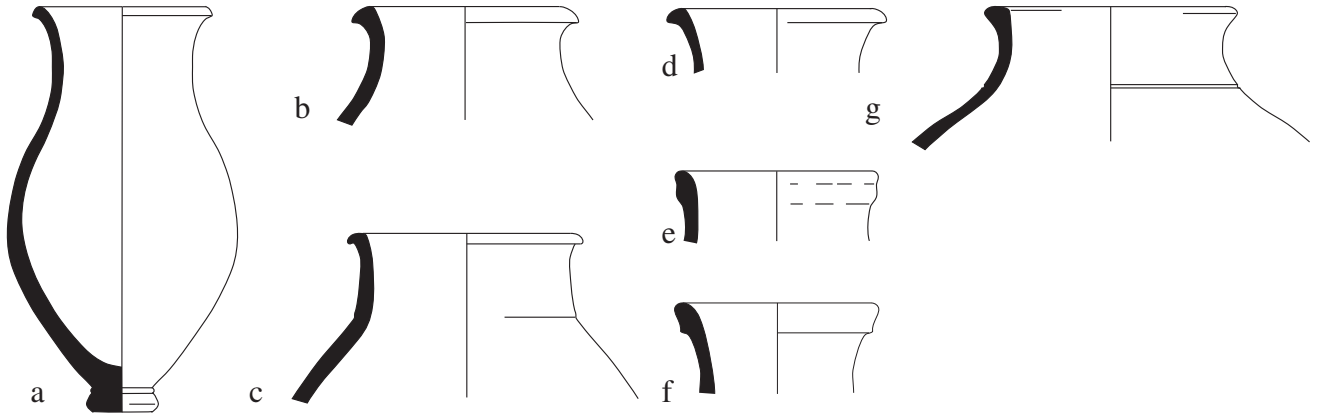

321

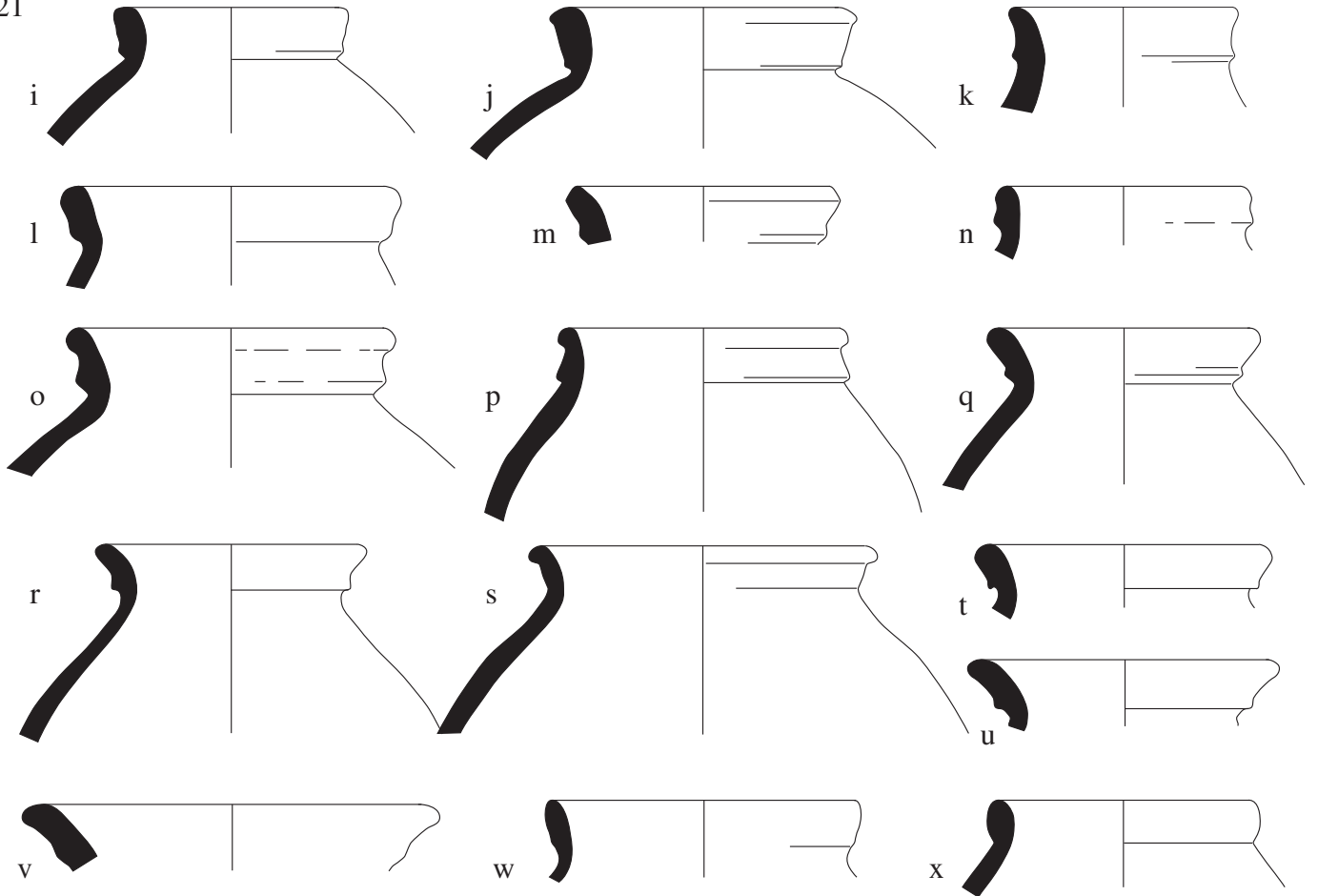

322
323



scale 1:4

figure no.	level	square	locus	lot	no.	technology	ware group	surface	colour inside	colour outside	colour fracture	decoration	special tr.	rim diameter	base diameter	rim type	base type	comparisons
IV.119.a	3	L9	17	046	2	C	2	2	5	5	5	1	0	90		333	-	
IV.119.b	3	L9	17	053	2	D	2	8	8	8	8	1	0	170		333	-	
IV.119.c	3	L9	29	021	3	C	2	4	4	4	4	1	0			333	-	
IV.119.d	3	L9	17	038	1	C	2	8	8	8	8	1	14	170		333	-	
IV.119.e	3	K10	19	030	87	A	2	2	2	2	2	1	0	110		411	-	
IV.119.f	3	K10	19	030	81	A	2	4	4	4		31	0	100		421	-	
IV.119.g	3	I9	23	052	P96-27	A	2	2	3	3	3	1	0	82	19	421	712	
IV.119.h	3	I10	16	036	4	A	2	4	4	4	4	1	0	90		431	-	(with handle?) Sheikh Hamad MA III (Pfälzner 1995: Taf. 146g).
IV.119.i	3	L12	3	004	8	B	2	4	4	4	4	1	0	40		431	-	
IV.119.j	3	K10	19	030	P91-81	B	2	3	3	3	3	1	0	200	210	611	611	
IV.119.k	3	I10	16	042	19	B	1	2	3	3	3	1	0	240		611	-	
IV.119.l	3	L11	22	026	3	B	1	2	2	2	3	1	0	160		611	-	
IV.119.m	3	J10	3	013	16	B	1	2	8	8	8	1	0	180		611	-	
IV.119.n	3	J9	80	183	P98-113	E	1	2	2	2	3	1	0			tray	tr	
IV.119.o	3	I10	16	026	5	I	1	2	6	2	3	1	0			-	-	
IV.119.p	3	K10	19	030	P91-224	I	2	2	3	3	3	1	0			var	var	

p

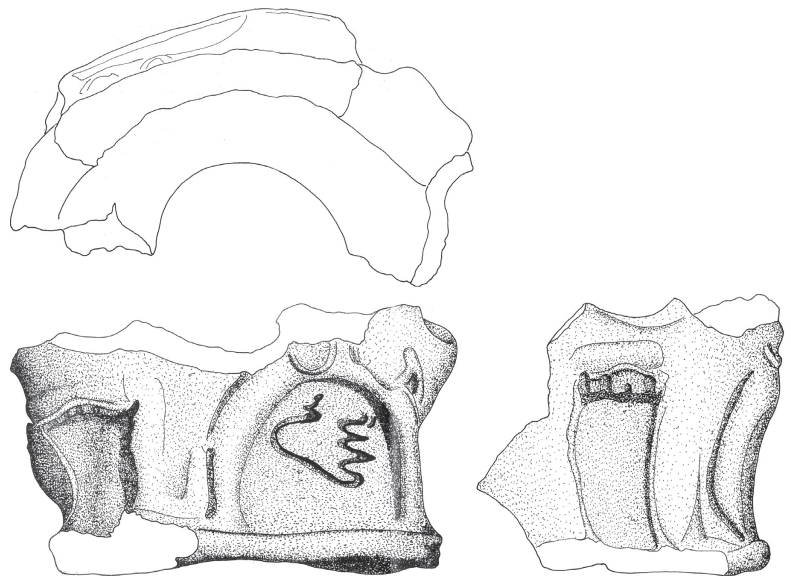

333



a



b



c



d

411

421

431



e

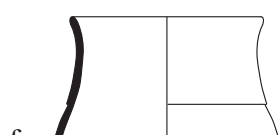

f

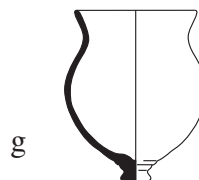

g



h



i

611

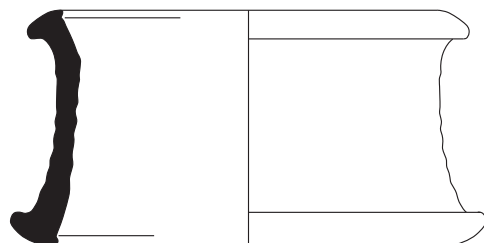

j

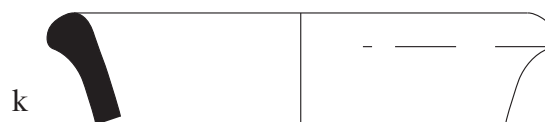

k

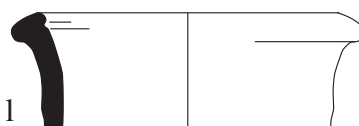

l

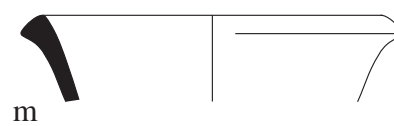

m

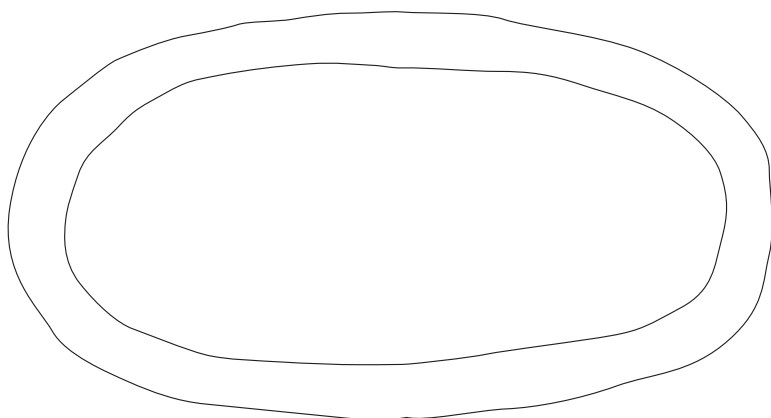

n



o

scale 1:4

figure no.	level	square	locus	lot	no.	technology	ware group	surface	colour inside	colour outside	colour fracture	decoration	special tr.	base diameter	base type	comparisons
IV.120.a	3	K10	19	030	138	A	A	2	3	3		1	9	6	711	
IV.120.b	3	K10	19	033	25	A	H	5	2	2		1	9	15	712	
IV.120.c	3	H10	3	011	8	A	B	2	7	7		1	0	12	712	
IV.120.d	3	K10	19	033	11	A	C	2	2	2	7	1	9	10	712	base: Teil Taban level 8 (Ohnuma et al. 2000: fig. 8 no. 29).
IV.120.e	3	K10	19	030	13	H	H	2	2	2		1	9	30	721	
IV.120.f	3	K10	19	030	18	I	I	2	2	2		1	0	55	731	
IV.120.g	3	J10	22	037	4	I	I	2	3	3	3	1	0	55	731	
IV.120.h	3	L9	23	020	3	C	C	2	3	3		1	0	90	741	(burnished)
IV.120.i	3	K10	19	030	105	I	I	4	2	2		1	0	90	741	
IV.120.j	3	H10	1	012	23	I	I	2	3	3	6	1	0	80	731	
IV.120.k	3	L9	34	052	2	A	A	5	3	2		1	0	751		(trace of a handle at the shoulder) Hadidi (Dornemann 1981: fig. 6 no. 5 (not very close), fig. 7).
IV.120.l	3	J10	22	037	5	I	I	2	2	2		1	23	751		

711
712

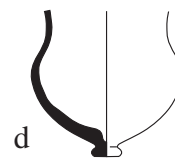

721

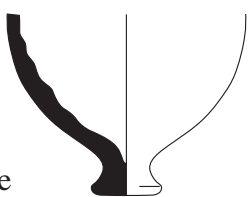

741

731

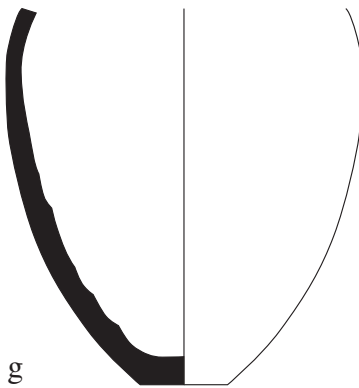
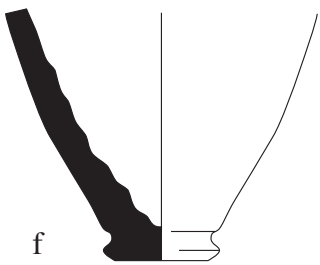

h



i



j

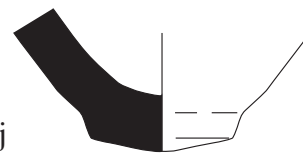

751

k



l

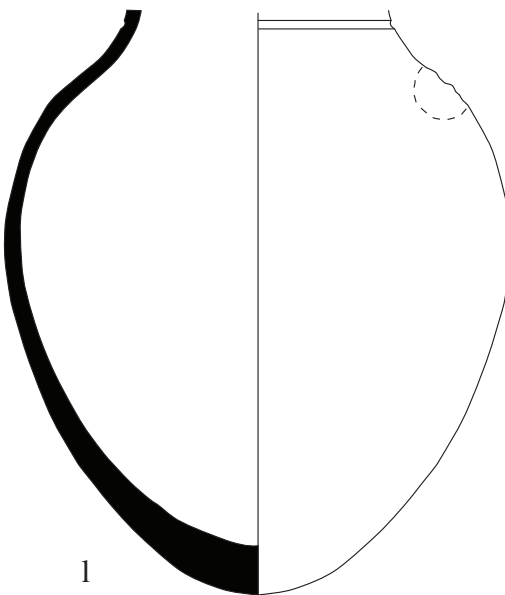

scale 1:4