



Universiteit
Leiden
The Netherlands

Endocrine and metabolic features of familial longevity : the Leiden Longevity Study

Rozing, M.P.

Citation

Rozing, M. P. (2011, September 21). *Endocrine and metabolic features of familial longevity : the Leiden Longevity Study*. Retrieved from <https://hdl.handle.net/1887/17849>

Version: Corrected Publisher's Version

License: [Licence agreement concerning inclusion of doctoral thesis in the Institutional Repository of the University of Leiden](#)

Downloaded from: <https://hdl.handle.net/1887/17849>

Note: To cite this publication please use the final published version (if applicable).

Chapter 1: General introduction to endocrine and metabolic features of familial longevity: the Leiden Longevity Study

Maarten P. Rozing^{1,3}, P. Eline Slagboom^{2,3}, Rudi G.J. Westendorp^{1,3}, Diana van Heemst^{1,3}, on behalf of the Leiden Longevity Study (LLS) Group

From the ¹Department of Gerontology and Geriatrics, ²Department of Medical Statistics, section Molecular Epidemiology, Department of Medical Statistics, Leiden University Medical Center, PO Box 9600, 2300 RC Leiden, The Netherlands, ³Netherlands Consortium of Healthy Aging (NCHA).



Chapter 1

World life expectancy has rapidly increased over the last two centuries, from roughly 25 years to about 65 years for males and 70 years for females ¹. Before 1950, the improvement in life expectancy was achieved through reductions in mortality at younger ages ². However, in the second half of the 20th century this improvement was mainly due to a gain in life-expectancy at older ages ³. Unfortunately, not all of the gained years of life are spent in good health. Currently extensive research in both model organisms and humans focuses at identifying the genetically determined pathways and mechanisms of healthy longevity. Understanding the role of these pathways and mechanisms in longevity might eventually reveal targets for interventions to prevent aging-related loss of function and disease⁴.

Various attempts have been made to identify genetic markers of the regulatory pathways that underlie human longevity. As yet, the results of these studies are hindered by an increase of genome diversity when extrapolating results from experimental models to men, hampered by the critical dependency on the environmental conditions in which the genes are expressed, and biased by the absence of a valid control group when studying exceptionally long-lived individuals. In search for the biology of healthy longevity, and to circumvent the methodological problems mentioned above, we set off to study the phenotypes of exceptionally long-lived families in the Leiden Longevity Study. Substantial evidence supports the familial clustering of exceptional longevity. The existence of families showing aggregation of this long-lived phenotype implies a genetic basis ⁵⁻⁷. In this overview, we report on the endocrine and metabolic characteristics that appear to be pertinent for familial healthy longevity.

Leiden Longevity Study

Studies into determinants of human longevity commonly compare age groups of unrelated individuals. These so-called cross-sectional designs are particularly prone to confounding as cases and controls originate from different birth cohorts. An alternative design is to study multiple generations from long-lived families. This study design has been applied to both centenarians or nonagenarians and their middle aged offspring, i.e. the New England Centenarian Study⁸ and the Ashkenazi Jewish Centenarian Study⁹, and more recently to nonagenarian sibling pairs and their middle aged offspring, Leiden Longevity Study¹⁰.

The study design of the Leiden Longevity Study is depicted in **figure 1**. Families were eligible for participation if two or more long-lived siblings were alive who met the age criteria of 89 years or over for males and 91 years or over for females. Along with the long-lived siblings, their offspring and partners thereof were enrolled. In total 944 long-lived siblings participated with a mean age of 93 years (ranging from 89 to 103 years), 1671 offspring (mean age of 59 years, range: 34-80 years) and 744 partners (mean age 59 years, range: 30-79 years).

Figure 1. Study design of the Leiden Longevity Study. Black symbols denote siblings eligible for inclusion based on achieved age. Arrows indicate proband siblings.

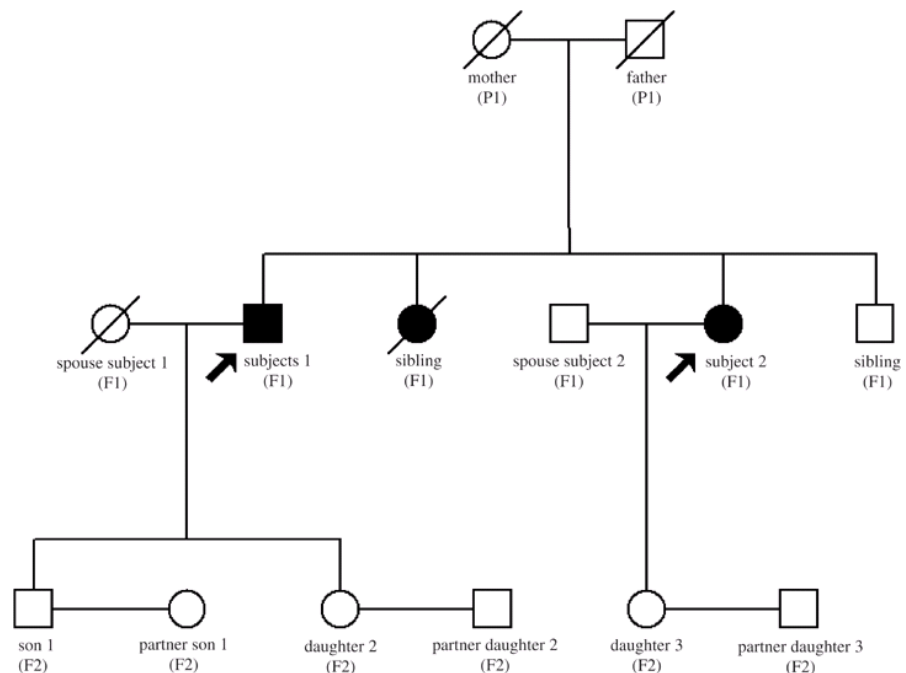

Our study design allowed for three approaches to identify longevity-associated phenotypes and underlying genotypes. First, we compared the group of familial nonagenarians with a group of sporadic nonagenarians (not selected on having nonagenarian siblings) from the Leiden 85-plus Study to distinguish between markers for familial longevity and markers for sporadic longevity.

Secondly, the offspring from long-lived individuals were compared to their middle aged partners as controls from the general population. Postulating that longevity-enabling genes are transmitted across generations, the offspring of long-lived nonagenarians represent cases predisposed for longevity, while their partners provided an appropriate control group. Finally, we calculated a family mortality history score which describes the mortality of the parents of the nonagenarian siblings compared to their birth cohort¹¹. We thereby reasoned that in nonagenarian siblings from parents with a lower family mortality history score, indicating a lower than average mortality, traits related to longevity would be more pronounced than in nonagenarian siblings from parents with a higher family mortality history score.

The Leiden 85 Plus Study

In the Leiden 85-plus Study, a prospective, population-based study of all individuals 85 years old (birth cohort 1912–1914) living in Leiden, the Netherlands, 599 subjects were enrolled between September 1997 and September 1999. Of the Leiden 85-plus cohort, 275 subjects survived to the age of 90 years.

Outline of this thesis

The first part of this thesis, part A, discusses the endocrine and metabolic characteristics of long-lived families as observed in the Longevity Study. In **chapter two** we investigate two critical indicators of aging retardation. We compare the (late life) risk of mortality of nonagenarian siblings with that of sporadic nonagenarians as population based controls. Further, we determine the prevalence of morbidity in their offspring as compared to their partners. The following three chapters address the role of insulin sensitivity and glucose regulation in familial longevity. In **chapter three** we firstly compare the prevalence of metabolic syndrome and its individual risk components between offspring of nonagenarian siblings and their partners. Secondly, we explore differences in glucose metabolism between offspring and partners by performing an oral glucose tolerance test. To compare tissue specific insulin action between offspring of long-lived siblings and controls, a double tracer, 2-step hyperinsulinaemic euglycaemic clamp was performed. Results of this experiment are given in **chapter four**. In **chapter five** we investigate the relation between low grade inflammation and glucose regulation in the two groups. Closely related to insulin sensitivity, is the IGF-1 signaling pathway. In **chapter six** and **seven** hallmark phenotypes of the IGF-1 signaling pathway (height and serum IGF-1 axis parameters) are presented for middle aged offspring and the nonagenarian siblings respectively. Another endocrine system implicated in modulating the aging process is the hypothalamo–pituitary–thyroid axis. This topic is treated in chapter eight to ten. **Chapter eight** and **nine** include the study of serum thyroid

hormone parameters in middle-aged offspring and nonagenarian siblings. **Chapter ten** explores a mutual relation between peripheral thyroid hormones and immune function in the Leiden 85-plus Study. **Chapter eleven** gives an overview of the main findings presented in this thesis and discusses their relation to the current state of the field of longevity research.

The second part of this thesis, part B, includes a critical appraisal of the definition of the rate of senescence. Classic inference from the Gompertz law of aging has led to the conclusion that the rate of senescence is unaffected by environmental conditions. In **chapter twelve** we propose an alternative method for assessment of the rate of senescence. In **chapter thirteen** we will empirically test this novel approach in a population of renal patients, a population known to experience accelerated aging.

Reference List

- (1) Riley J. *Rising Life Expectancy: A Global History*. Cambridge: Cambridge Univ. Press, 2001.
- (2) Wilmoth JR, Deegan LJ, Lundstrom H, Horiuchi S. Increase of maximum life-span in Sweden, 1861-1999. *Science* 2000;289:2366-2368.
- (3) Oeppen J, Vaupel JW. Demography. Broken limits to life expectancy. *Science* 2002;296:1029-1031.
- (4) Fontana L, Partridge L, Longo VD. Extending healthy life span--from yeast to humans. *Science* 2010;328:321-326.
- (5) Gudmundsson H, Gudbjartsson DF, Frigge M, Gulcher JR, Stefansson K. Inheritance of human longevity in Iceland. *Eur J Hum Genet* 2000;8:743-749.
- (6) Skytthe A, Pedersen NL, Kaprio J et al. Longevity studies in GenomEUtwin. *Twin Res* 2003;6:448-454.
- (7) Hjelmborg J, Iachine I, Skytthe A et al. Genetic influence on human lifespan and longevity. *Hum Genet* 2006;119:312-321.
- (8) Perls TT, Wilmoth J, Levenson R et al. Life-long sustained mortality advantage of siblings of centenarians. *Proc Natl Acad Sci U S A* 2002;99:8442-8447.
- (9) Atzmon G, Schechter C, Greiner W, Davidson D, Rennert G, Barzilai N. Clinical phenotype of families with longevity. *J Am Geriatr Soc* 2004;52:274-277.
- (10) Schoenmaker M, de Craen AJ, de Meijer PH et al. Evidence of genetic enrichment for exceptional survival using a family approach: the Leiden Longevity Study. *Eur J Hum Genet* 2006;14:79-84.
- (11) Houwing-Duistermaat JJ, Callegaro A, Beekman M, Westendorp RG, Slagboom PE, van Houwelingen JC. Weighted statistics for aggregation and linkage analysis of human longevity in selected families: the Leiden Longevity Study. *Stat Med* 2009;28:140-151.