



Universiteit
Leiden
The Netherlands

Production and characterization of recombinant human lactoferrin

Veen, H.A. van

Citation

Veen, H. A. van. (2008, April 23). *Production and characterization of recombinant human lactoferrin*. Retrieved from <https://hdl.handle.net/1887/13570>

Version: Corrected Publisher's Version

License: [Licence agreement concerning inclusion of doctoral thesis in the Institutional Repository of the University of Leiden](#)

Downloaded from: <https://hdl.handle.net/1887/13570>

Note: To cite this publication please use the final published version (if applicable).

Production and characterization of recombinant human lactoferrin



Harrie van Veen

Production and characterization of recombinant human lactoferrin

Production and characterization of recombinant human lactoferrin

Proefschrift

ter verkrijging van
de graad van Doctor aan de Universiteit Leiden,
op gezag van Rector Magnificus prof.mr. P.F. van der Heijden,
volgens besluit van het College voor Promoties
te verdedigen op woensdag 23 april 2008
klokke 16.15 uur

door

Henricus Antonius van Veen

geboren te Boskoop in 1969

Promotiecommissie

Promotor: Prof.dr. H.A. de Boer

Co-promotoren: Dr. P.H.C. van Berkel
Dr. J.H. Nuijens

Referent: Prof.dr. G.W. Canters

Overige leden: Prof.dr. J.P. Abrahams
Prof.dr. M.R. Daha
Prof.dr. C.E. Hack (VU)
Dr. P.H. Nibbering

Cover: Jaco Koiter

The studies described in this thesis were financially supported by Pharming Group NV, Leiden, The Netherlands.

Voor mijn vader

Abbreviations	8
Chapter 1 Introduction	9
Chapter 2 Analytical cation-exchange chromatography to assess the identity, purity and N-terminal integrity of human lactoferrin <i>Anal. Biochem. (2002) 309: 60-66</i>	21
Chapter 3 Characterization of monoclonal antibodies against human lactoferrin <i>J. Immunol. Meth. (2002) 267: 139-150</i>	29
Chapter 4 Characterization of the recombinant N- and C-lobe of human lactoferrin	41
Chapter 5 Large scale production of recombinant human lactoferrin in the milk of transgenic cows <i>Nat. Biotechnol. (2002) 20: 484-487</i>	53
Chapter 6 The protein structure of recombinant human lactoferrin produced in the milk of transgenic cows closely matches the structure of human milk-derived lactoferrin <i>Transgenic Res. (2005)14:397-405</i>	59
Chapter 7 The role of N-linked glycosylation in the protection of human and bovine lactoferrin against tryptic proteolysis <i>Eur. J. Biochem. (2004) 271: 678-684</i>	69
Chapter 8 Characterization of bovine neutrophil gelatinase-associated lipocalin <i>J. Dairy Sci. (2006) 89: 3400-3407</i>	77
Chapter 9 Sub-chronic (13-week) oral toxicity study in rats with recombinant human lactoferrin produced in the milk of transgenic cows <i>Food Chem. Toxicol. (2006) 44: 964-973</i>	85
Chapter 10 Summary and general conclusions	95
Samenvatting	105
Curriculum Vitae	111

24p3	:	mouse 24p3/uterocalin
A2UMRP	:	rat α_2 -microglobulin-related protein
bLF	:	bovine LF
bNGAL	:	bovine neutrophil gelatinase-associated lipocalin
bSA	:	bovine serum albumin
EDTA	:	ethylene diamine tetra-acetic acid
ELISA	:	enzyme-linked immunosorbent assay
Fe-hLF	:	iron-saturated hLF
hLF	:	human LF
hNGAL	:	human neutrophil gelatinase-associated lipocalin
hTF	:	human transferrin
Kd	:	dissociation constant
LF	:	lactoferrin
Lfc	:	lactoferricin
LPS	:	lipopolysaccharide
mAb	:	monoclonal antibody
Mr	:	relative molecular weight
NK	:	natural killer
NOAEL	:	no-observed-adverse-effect level
PBS	:	phosphate buffered saline
PDB	:	protein data bank
PTG	:	PBS-Tween-Gelatine
pI	:	isoelectric point
pLF	:	porcine lactoferrin
rC-lobe	:	recombinant C-lobe
rhLF	:	recombinant hLF
rhLF ^{cDNA}	:	rhLF derived from the Rey hLF-cDNA sequence
rhLF ^{gen}	:	rhLF derived from an hLF-genomic DNA sequence
rhLF ^{Gln138/479}	:	rhLF ^{cDNA} with mutations Thr ¹³⁰ →Ile, Cys ⁴⁰⁴ →Gly, Asn ^{138/479} →Gln
RIA	:	radioimmunoassay
rms	:	root mean square
rN-lobe	:	recombinant N-lobe
SBTI	:	soybean trypsin inhibitor
SDS-PAGE	:	sodium dodecyl sulfate-polyacrylamide gel electrophoresis

Chapter 1

Introduction

1. General

Lactoferrin (LF) is an iron-binding glycoprotein that belongs to the transferrin family. This family of proteins is widely distributed in vertebrates and invertebrates [1]. Most members of the transferrin family evolved from an ancient gene duplication event, which resulted in a single polypeptide of about Mr 80,000 folded into two homologous lobes [1]. In LF, each lobe can bind a single ferric ion giving the protein a characteristic red color [2]. LF was first reported in 1939 by Sørensen and Sørensen, who separated a “red protein fraction” from cow milk [3]. In 1960, substantial purity of LF was obtained allowing characterization studies [2, 4]. These studies revealed that LF closely relates to transferrin, an abundant serum protein involved in the transport of iron to cells [5]. However, the affinity for iron appeared to be about 300 times higher for LF when compared to transferrin [6] and initial functions ascribed to LF related to this feature i.e. limiting of bacterial growth through iron deprivation [7, 8]. Since then extensive research, both in vitro as well as in vivo, has been performed showing that LF is involved in the innate host defence against infection and severe inflammation, most notably at mucosal surfaces. The diverse functions of LF relate to its binding of iron, binding to a variety of ligands and interactions with specific receptors [9-11].

2. Biosynthesis

Lactoferrin is synthesized by glandular epithelial cells and secreted into milk, tears, saliva, nasal fluids, pancreatic-, bronchial-, gastrointestinal- and reproductive tissue secretions [9]. The concentration of LF in milk varies considerably among species. Human milk has the highest LF concentration (1-6 mg/ml); mouse milk has moderate levels of LF (1-2 mg/ml) and milks from ruminants have relatively low levels of LF (0.01-0.1 mg/ml). Milks from rabbits and rats contain virtually no LF [10]. The LF concentration in lacteal secretions varies also within the lactation phase. In human milk, the LF concentration can be as high as 10 mg/ml in colostrum declining to about 1-2 mg/ml in mature milk. The concentration of bovine LF (bLF) is about 1-2 mg/ml and 0.01-0.1 mg/ml in bovine colostrum and mature milk, respectively [10]. Upon involution of the human and bovine mammary gland, the LF concentration increases to about 50 mg/ml and 20-100 mg/ml, respectively [10]. The concentration of LF in human saliva and tears is about 30 µg/ml and 2 mg/ml, respectively [12, 13].

LF is also released from the secondary granules of activated neutrophils [14]. This process likely accounts for the presence of LF in normal blood plasma at a concentration of about 0.2 µg/ml [15]. In patients with sepsis the levels of LF in plasma are increased to about 1 µg/ml [15]. The level of LF in synovial fluid of patients with non-inflammatory joint diseases is about 0.7 µg/ml; in patients with inflammatory joint diseases the level of LF in synovial fluid is increased to about 4 µg/ml [16].

LF is efficiently removed from the circulation by the liver. Studies in rats showed that about 95% of intravenously administered LF (0.25 mg/kg body weight) is cleared by the liver within 5 minutes [17].

3. Structure of human lactoferrin

Human LF (hLF) consists of a single polypeptide chain of 692 amino acids [18]. The polypeptide is folded into two globular lobes, designated the N- and C-lobe, connected by an α -helix (Figure 1). Each lobe in turn is folded into α -helix and β -sheet arrays to form two domains (I and II), connected by a

hinge region, creating a deep iron-binding cleft within each lobe. Each cleft binds a single ferric ion with high affinity ($K \sim 10^{22}$ M) while simultaneously incorporating a suitable anion such as carbonate or oxalate [19]. The ligands involved in the binding of the ferric ion are the same for both lobes and comprise of two tyrosine residues, one aspartate and one histidine together with two oxygen atoms from the incorporated anion [19].

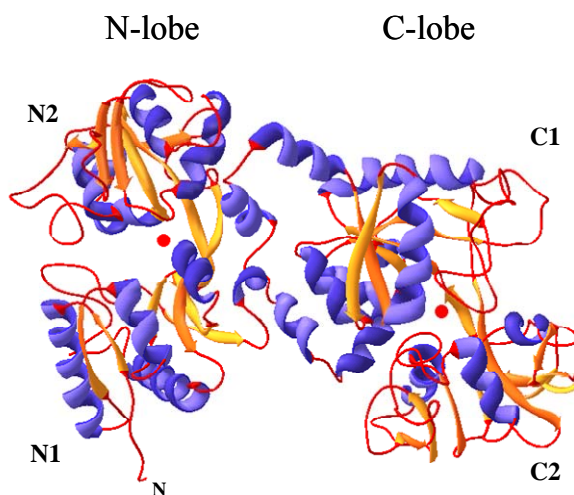

Figure 1 Protein structure of human lactoferrin

The structure of hLF, in its iron-saturated conformation [20], shows the typical bilobal (N- and C-lobe), four domain (N1/N2, C1/C2) folding pattern which is characteristic for proteins of the transferrin family [19]. The α -helices and β -strands are indicated in blue and yellow, respectively. The two iron ions are indicated by red spheres.

Crystallographic studies of hLF have shown that upon binding of iron, domain I of the N- and C-lobe rotates relative to domain II by $\sim 54^\circ$ and $\sim 20^\circ$, respectively, resulting in a more globular, and stable conformation of the entire molecule. This conformational change was also observed upon incorporation of other metals such as manganese, zinc and copper [19].

Whereas some of the biological activities of hLF relate to metal-binding (e.g. limiting bacterial growth through iron sequestration), others are mediated by unique positively charged domains located in the N-terminus i.e. Arg²-Arg³-Arg⁴-Arg⁵ and Arg²⁸-Lys²⁹-Val³⁰-Arg³¹, which are juxtaposed to form a cationic cradle [21]. These basic clusters determine the relatively high isoelectric point (pI of 8.7) of hLF [22] and are involved in the binding of hLF to negatively charged ligands such as the lipid A moiety of lipopolysaccharide (LPS) [23], DNA [24], heparin [21], other proteins such as lysozyme [25] as well as cell-surface molecules such as proteoglycans and specific receptors [26, 27]. The release of the positively charged domains from hLF by pepsin action yields lactoferricin (residues Gly¹ to Ile⁴⁷), which is a potent bactericidal peptide [28]. Human LF contains three possible N-glycosylation sites, Asn¹³⁸ in the N-lobe and Asn⁴⁷⁹ as well as Asn⁶²⁴ in the C-lobe [18], which are utilized in about 94%, 100% and 9% of the molecules, respectively [29]. The glycans of natural hLF are of the sialyl-N-acetyllactosaminic type [30].

4. Biological actions of lactoferrin

Extensive research has showed that LF is involved in the innate host defence against infection and severe inflammation. The diverse functions of LF relate to its binding of iron, non-specific binding to a

variety of negatively charged ligands and interactions with specific receptors. Figure 2 provides an overview of biological activities postulated for LF.

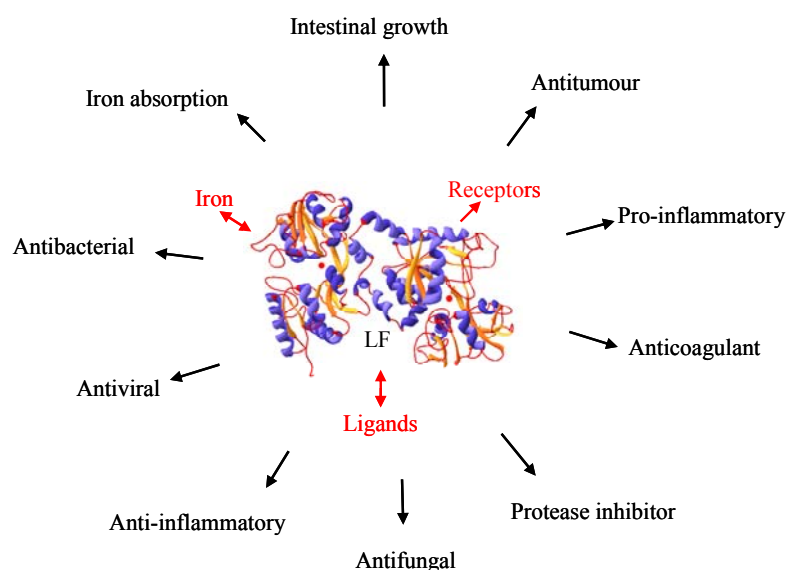

Figure 2 Overview of biological activities postulated for lactoferrin (LF)

One of the first functions ascribed to LF was growth-inhibition of Gram-positive and Gram-negative bacteria by sequestration of environmental iron [7, 8, 31]. In addition, iron deprivation by LF inhibits biofilm formation of *Pseudomonas Aeruginosa* [32]. These antimicrobial activities are reversible as bacterial growth was restored upon the addition of an excess of iron. Some microorganisms such as *Neisseria meningitidis* and *Haemophilus influenzae* can acquire iron from iron-saturated LF through specific receptors for the molecule [33]. Furthermore, LF has been shown to promote the growth of *Bifidobacterium* species [34, 35], the predominant bacteria of the intestinal flora of healthy breast-fed infants.

Besides bacteriostasis, bactericidal activity of LF by destabilization of the cell-wall of Gram-positive and Gram-negative bacteria has been reported [36, 37]. Destabilization of the cell-wall by LF has also been reported for several *Candida* species [38]. The cell-wall destabilization results from the binding of LF to membrane-molecules such as porins [39] and LPS [40, 41]. Furthermore, the binding of LF to membrane molecules, mostly glycosaminoglycans, inhibits cell adhesion and invasion of a large variety of pathogens, including enterovirulent strains of *Escherichia coli* [42, 43] and *Shigella* [44], *Listeria monocytogenes* [45], human cytomegalovirus [46, 47], human herpes simplex virus [46], human immunodeficiency virus [47] and human hepatitis B and C viruses [48, 49]. Besides binding of LF to membrane molecules, LF-mediated proteolysis of molecules involved in the invasion of pathogens (e.g. bacterial invasins) has been reported [50, 51].

The antibacterial, antiviral and antifungal activities of LF have been confirmed by studies in rodents experimentally infected with a variety of pathogens including *Listeria monocytogenes* [52], *Escherichia coli* [53], *Staphylococcus aureus* [54], herpes simplex virus [55], influenza virus [56] and *Candida albicans* [57].

The anti-inflammatory activities of LF include inhibition of hydroxyl-radical ($\bullet\text{OH}$) formation by scavenging of iron [58] and inhibition of mast cell tryptase activity by dissociation of the tryptase/heparin complex [59]. As a results of these anti-inflammatory activities LF abolished late phase airway responses (through inhibition of mast cell tryptase activity) in allergic sheep [59] and decreased

pollen antigen-induced airway inflammation in a murine asthma model by reducing the generation of reactive oxygen species (ROS) such as $\bullet\text{OH}$ [60]. The inhibition of ROS formation by LF has also been postulated as mode of action for reducing inflammation in joints of murine arthritis models [61].

Another anti-inflammatory activity of LF is neutralization of LPS, which is a major mediator of inflammatory responses after bacterial infection [62]. LF binds to the lipid A moiety of LPS with high affinity ($K_d \sim 4 \text{ nM}$) [23, 63] and competitively inhibits binding of LPS to LPS-binding protein [64]. Furthermore, LF has been shown to inhibit LPS-induced expression of endothelial adhesion molecules through binding to sCD14 and the sCD14-LPS complex [65]. The neutralization of LPS activity by LF has been demonstrated in vivo since LF protected against LPS-induced lethal shock in mice and germ-free piglets [66-68].

LF is involved in the modulation of immune cell activity (recruitment, activation and/or proliferation) of a variety of immune cells such as monocytes/macrophages and natural killer (NK) cells in vitro as well as in vivo [69]. The activation of NK cells contributes to the antitumour activities ascribed to the molecule, which include also modulation of various signaling pathways [9]. The antitumour activities of LF, administered either orally, intraperitoneally, subcutaneously or intratumorally, has been established for a broad range of tumors experimentally induced in rodents [70-74]. Orally administered hLF at doses of 1.5 to 9 g/day using a two weeks on, 2 weeks off schedule inhibited growth of refractory solid tumors, especially of non-small cell lung cancer (NSCLC), in humans [75]. In addition, orally administered hLF has been shown to potentiate conventional chemotherapy in mouse models with established human and mouse tumors [72] and in humans with NSCLC [76].

The modulation of cellular processes by LF is mediated by neutralization of potent stimuli of host immunological responses such as LPS [62] and bacterial unmethylated CpG-containing oligonucleotides [77]. Besides the neutralization of potent inflammatory stimulators, the molecule can modulate cellular processes by binding to receptors and subsequent intracellular signaling pathways [78-81]. Specific receptors for LF have been found on a variety of cells including monocytes [82], lymphocytes [83], liver- [27] and intestinal cells [84]. The presence of a LF-receptor on intestinal cells may explain for the role of LF in iron-absorption in the gut [84]. In addition, LF has been shown to promote the growth of intestinal cells in vitro [85] and in vivo [86] which may explain for the protective effect LF displayed after experimental induced enteropathy in rodents [87, 88] and healthy volunteers [89]. Similarly to protection of intestinal epithelial, prior application of LF suppressed damage of corneal epithelial induced by UV-B [90, 91].

The anticoagulant activities ascribed to LF are related to the binding of glycosaminoglycans such as heparin. LF neutralized heparin activity comparable to platelet factor 4 but was more effective than protamine sulphate [92].

5. Applications of lactoferrin

The diverse biological actions of LF may provide a basis for a large variety of potential nutraceutical as well as topical and systemic applications in human healthcare. The applications may include the prevention and treatment of local or systemic infections and (chronic) inflammations such as occurring in patients with inflammatory bowel diseases, patients receiving high-dose chemotherapy and patients with allergic asthma. Furthermore, LF may be suitable for neutralization of heparin activity after its use as anticoagulant in surgery.

Both hLF and bLF, obtained after fractionation of bovine milk whey, can be used in applications of LF in human health care. However, the use of bLF in human healthcare is limited to oral applications because of its immunogenicity. Furthermore, bLF may be inferior to hLF in applications where interactions with specific receptors are required.

6. Production of recombinant human lactoferrin

The limited availability of human milk and purified hLF has been a major hurdle for (clinical) studies on potential nutraceutical and pharmaceutical applications of hLF. To overcome this limitation, the feasibility of large-scale production of functional recombinant hLF (rhLF) was studied in a variety of expression systems (Table 1). Expression of recombinant hLF (rhLF), at relatively low levels, has been reported for mammalian cells, fungi, yeast, baculovirus-based expression systems and transgenic plants and rabbits. Higher expression levels of rhLF have been reported for *Aspergillus awamori*, transgenic mice, transgenic rice and various transgenic plant cell culture systems (Table 1).

Table 1 Expression of rhLF in various expression systems

Expression system	rhLF expression	Reference
BHK cell culture	~20 µg/ml	[93]
Human 293(S) cell culture	~1 µg/ml	[25]
<i>Aspergillus Oryzae</i>	~25 µg/ml	[94]
<i>Saccharomyces cerevisiae</i>	~2 µg/ml	[95]
Baculovirus/Sf9 cell culture	~15 µg/ml	[96]
Transgenic potato plants	~0.1% of soluble protein	[97]
Transgenic tobacco plants	~0.3% of soluble protein	[98]
Transgenic rabbits	~0.1 mg/ml	[99]
Baculovirus/silkworm larvae	~0.2 mg/ml	[100]
Transgenic tobacco cell culture	~4% of soluble protein	[101]
Transgenic ginseng cell culture	~3% of soluble protein	[102]
Transgenic rice cell culture	~4% of soluble protein	[103]
<i>Aspergillus awamori</i>	~2 mg/ml	[104]
Transgenic mice	~13 mg/ml	[105]
Transgenic rice	~5 g/kg grain	[106]

A disadvantage of most expression systems is that rhLF, in contrast to human-derived hLF, is secreted in its iron-saturated form probably due to the presence of excess of metals during culturing [25, 95]. Such rhLF preparations thus require desaturation (e.g. pH < 3) to obtain biological activities based on the binding of iron. Furthermore, the organism used for expression determines the carbohydrate composition and structures of the glycan chains because glycosylation is species, tissue, cell type and protein-specific [107, 108]. For the parenteral route of administration, the presence of non-human sugar moieties and/or glycan chains may turn them into antigenic determinants [109, 110] and thereby may impair the (immuno) safety of the rhLF containing drug.

Transgenic cows expressing hLF in milk could provide a suitable means to produce large quantities of hLF as one cow can produce annually about 10,000 liters of milk. The costs associated with maintaining transgenic cows are futile as compared to those of large scale mammalian cell-culture based expression systems. In addition, environmental concerns raised for transgenic plants i.e. uncontrolled dissemination of genes to non-transgenic plants don't apply for transgenic cows [111, 112]. Previously, we reported the generation of transgenic cows harbouring mammary gland-specific bovine α S1-casein promoter and hLF cDNA-based expression vectors [113].

7. Outline of thesis

The expression and characterization of rhLF produced in the milk of transgenic cows, bearing the hLF gene under control of the bovine α S1-casein promoter, are described in this thesis.

In Chapter 2 a robust analytical method to assess the identity, purity and N-terminal integrity of hLF preparations is described. The method, employing cation-exchange chromatography on a Mono S column, can discriminate between intact hLF and hLF molecules lacking two or three N-terminal residues, lactoferrins from other species as well as homologous and other whey proteins.

In Chapter 3 the generation and characterization of ten distinct monoclonal antibodies (mAbs) against hLF is described. Localization of the epitopes for these anti-hLF mAbs by using proteolytic hLF fragments and the recombinant hLF lobes revealed that five mAbs could bind to conformational epitopes residing in the N-lobe of hLF, whereas the other five could bind to C-lobe conformational epitopes. One mAb, designated E11, appeared to bind to the arginine-rich N-terminus of hLF. The characterization of the recombinant hLF lobes used for characterization of the anti-hLF mAbs is described in Chapter 4. The recombinant hLF lobes were expressed in human 293(S) cells and the purified lobes were characterized by determining the N-terminal amino acid sequences, the heterogeneity in N-linked glycosylation, the binding of metals like iron and ligands like heparin and LPS. The results confirmed that the major iron-binding associated conformational change and the interaction with lipid A and heparin is determined by the N-lobe of hLF. In addition, the N-linked glycan of the N-lobe is not essential for maintaining the stability of the iron-saturated conformation.

In Chapter 5 the production of rhLF in the milk of transgenic cows is described. Recombinant hLF was expressed at high concentrations in milk (~2.5 g/l) and mainly (> 90%) in its unsaturated form. Comparative characterization studies between rhLF and hLF from human milk revealed identical iron-binding and iron-release properties and, despite differences in N-linked glycosylation, equal effectiveness in various infection models. Crystal structure analysis revealed that the protein structure of iron-saturated rhLF closely matches the structure of iron-saturated hLF from human milk (Chapter 6).

In Chapter 7 two variants of bLF (bLF A and B) are described. These bLF variants differ in utilization of glycosylation-site Asn²⁸¹ and resistance to tryptic proteolysis. In contrast to bLF, N-linked glycosylation is not needed for protection of hLF against tryptic proteolysis. Both recombinant and human milk hLF appeared about 100-fold less susceptible to tryptic proteolysis than bLF (Chapter 7).

The characterization of bovine neutrophil gelatinase-associated lipocalin (bNGAL), which is a potential contaminant of purified LF preparations, is described in Chapter 8. Bovine NGAL was identified based on N-terminal sequence identity with the sequence predicted for the bovine homologue of human neutrophil gelatinase-associated lipocalin (hNGAL), a glycoprotein of Mr 25,000 belonging to the family of lipocalins. A specific ELISA was developed to detect bNGAL in milk and purified LF preparations.

The oral safety of rhLF investigated in Wistar rats is described in Chapter 9. Recombinant hLF was administered daily, via oral gavage, at doses ranging from 0.2 to 2.0 g/kg body weight/day for 13 consecutive weeks and a large variety of clinical and laboratory safety parameters were monitored. These parameters revealed no treatment-related, toxicologically significant changes on the basis of which the no observed-adverse-effect level (NOAEL) was determined on 2 g/kg body weight/day. The summary and general conclusions of this thesis are provided in Chapter 10.

References

1. Lambert LA, Perri H & Meehan TJ (2005) Evolution of duplications in the transferrin family of proteins, *Comp Biochem Physiol B Biochem Mol Biol* **140**, 11-25.
2. Groves ML (1960) Isolation of a red protein from milk, *J Am Chem Soc* **82**, 3345-3350.
3. Sorensen M & Sorensen SPL (1939) The proteins in whey, *CR Trav Lab Carlsberg* **23**, 55-99.
4. Johanson B (1960) Isolation of an iron-binding red protein from human milk, *Acta Chem Scand* **14**, 510-512.
5. Crichton RR (1990) Proteins of iron storage and transport, *Adv Prot Chem* **40**, 281-363.
6. Aisen P & Leibman A (1972) Lactoferrin and transferrin: a comparative study, *Biochim Biophys Acta* **257**, 314-323.
7. Bullen JJ, Rogers HJ & Leigh L (1972) Iron-binding proteins in milk and resistance to *Escherichia coli* infection in infants, *Brit Med J* **1**, 69-75.
8. Reiter B, Brock JH & Steel ED (1975) Inhibition of *Escherichia coli* by bovine colostrum and post-colostral milk. II. The bacteriostatic effect of lactoferrin on a serum-susceptible and serum-resistant strain of *E. coli.*, *Immunology* **28**, 83-95.
9. Ward PP, Paz E & Conneely OM (2005) Multifunctional roles of lactoferrin: a critical overview, *Cell Mol Life Sci* **62**, 2540-2548.
10. Nuijens JH, van Berkel PHC & Schanbacher FL (1996) Structure and biological actions of lactoferrin, *Journal of Mammary Gland Biology and Neoplasia* **1**, 285-295.
11. Suzuki YA, Lopez V & Lönnerdal B (2005) Mammalian lactoferrin receptors: structure and function, *Cell Mol Life Sci* **62**, 2560-75.
12. Kijlstra A, Jeurissen SH & Koning KM (1983) Lactoferrin levels in normal human tears, *Br J Ophthalmol* **67**, 199-202.
13. Tanida T, Okamoto T, Okamoto A, Wang H, Hamada T, Ueta E & Osaki T (2003) Decreased excretion of antimicrobial proteins and peptides in saliva of patients with oral candidiasis, *J Oral Pathol Med* **32**, 586-594.
14. Baggiolini M, DeDuve, C., Masson, P. L. and Heremans, J. F. (1970) Association of lactoferrin with specific granules in rabbit heterophil leukocytes, *J Exp Med* **131**, 559-570.
15. Nuijens JH, Abbink JJ, Wachtfogel YT, Colman RW, Eerenberg AJ, Dors D, Kamp AJ, Strack van Schijndel RJ, Thijs LG & Hack CE (1992) Plasma elastase alpha 1-antitrypsin and lactoferrin in sepsis: evidence for neutrophils as mediators in fatal sepsis, *J Lab Clin Med* **119**, 159-168.
16. Abbink JJ, Kamp AM, Nieuwenhuys EJ, Nuijens JH, Swaak AJ & Hack CE (1991) Predominant role of neutrophils in the inactivation of alpha 2-macroglobulin in arthritic joints, *Arthritis Rheum* **34**, 1139-1150.
17. Ziere GJ, C vDM, Bijsterbosch MK & van Berkel TJ (1992) Lactoferrin uptake by the rat liver. Characterization of the recognition site and effect of selective modification of arginine residues, *J Biol Chem* **267**, 11229-11235.
18. Rey MW, Woloshuk SL, de Boer HA & Pieper FR (1990) Complete nucleotide sequence of human mammary gland lactoferrin, *Nucleic Acids Res* **18**, 5288.
19. Baker EN & Baker HM (2005) Molecular structure, binding properties and dynamics of lactoferrin, *Cell Mol Life Sci* **62**, 2531-2539.
20. Haridas M, Anderson BF & Baker EN (1995) Structure of human diferric lactoferrin refined at 2.2 Å resolution, *Acta Cryst* **D51**, 629-646.
21. Mann DM, Romm E & Migliorini M (1994) Delineation of the glycosaminoglycan-binding site in the human inflammatory response protein lactoferrin, *J Biol Chem* **269**, 23661-23667.
22. Moguilevsky N, Retegui LA & Masson PL (1985) Comparison of human lactoferrins from milk and neutrophilic leucocytes. Relative molecular mass, isoelectric point, iron-binding properties and uptake by the liver, *Biochem J* **229**, 353-359.

23. Appelmelk BJ, An YQ, Geerts M, Thijs BG, de Boer HA, MacLaren DM, de Graaff J & Nuijens JH (1994) Lactoferrin is a lipid A-binding protein, *Infect Immun* **62**, 2628-2632.
24. He J & Furmanski P (1995) Sequence specificity and transcriptional activation in the binding of lactoferrin to DNA, *Nature* **373**, 721-724.
25. van Berkel PHC, Geerts MEJ, van Veen HA, Kooiman PM, Pieper F, de Boer HA & Nuijens JH (1995) Glycosylated and unglycosylated human lactoferrins can both bind iron and have identical affinities towards human lysozyme and bacterial lipopolysaccharide, but differ in their susceptibility towards tryptic proteolysis, *Biochem J* **312**, 107-114.
26. Legrand D, van Berkel PH, Salmon V, van Veen HA, Slomianny MC, Nuijens JH & Spik G (1997) The N-terminal Arg2, Arg3 and Arg4 of human lactoferrin interact with sulphated molecules but not with the receptor present on Jurkat human lymphoblastic T-cells, *Biochem J* **327**, 841-846.
27. Ziere GJ, Bijsterbosch MK & van Berkel TJ (1993) Removal of 14 N-terminal amino acids of lactoferrin enhances its affinity for parenchymal liver cells and potentiates the inhibition of beta-very low density lipoprotein binding, *J Biol Chem* **268**, 27069-27075.
28. Tomita M, Takase M, Wakabayashi H & Bellamy W (1994) Antimicrobial peptides of lactoferrin, *Adv Exp Med Biol* **357**, 209-218.
29. van Berkel PH, van Veen HA, Geerts ME, de Boer HA & Nuijens JH (1996) Heterogeneity in utilization of N-glycosylation sites Asn624 and Asn138 in human lactoferrin: a study with glycosylation-site mutants, *Biochem J* **319**, 117-122.
30. Spik G, Strecker G, Fournet B, Bouquelet S, Montreuil J, Dorland L, Van Halbeek H & Vliegthart JFG (1982) Primary structure of the glycans from human lactotransferrin, *Eur J Biochem* **121**, 413-419.
31. Weinberg ED (1984) Iron withholding: a defense against infection and neoplasia, *Physiol Rev* **64**, 65-102.
32. Singh PK, Parsek MR, Greenberg EP & Welsh MJ (2002) A component of innate immunity prevents bacterial biofilm development, *Nature* **417**, 552-555.
33. Gray-Owen SD & Schryvers AB (1996) Bacterial transferrin and lactoferrin receptors, *Trends Microbiol* **4**, 185-191.
34. Kim WS, Ohashi M, Tanaka T, Kumura H, Kim GY, Kwon IK, Goh JS & Shimazaki K (2004) Growth-promoting effects of lactoferrin on *L. acidophilus* and *Bifidobacterium* spp, *Biometals* **17**, 279-283.
35. Petschow BW & Talbott RD (1991) Response of bifidobacterium species to growth promoters in human and cow milk, *Pediatr Res* **29**, 208-213.
36. Arnold RR, Cole MF & McGhee JR (1977) A bactericidal effect for human lactoferrin, *Science* **197**, 263-265.
37. Arnold RR, Russell JE, Champion WJ, Brewer M & Gauthier JJ (1982) Bactericidal activity of human lactoferrin: differentiation from the stasis of iron deprivation, *Infect Immun* **35**, 792-799.
38. Xu YY, Samaranayake YH, Samaranayake LP & Nikawa H (1999) In vitro susceptibility of *Candida* species to lactoferrin, *Med Mycol* **37**, 35-41.
39. Sallmann FR, Baveye-Descamps S, Pattus F, Salmon V, Branza N, Spik G & Legrand D (1999) Porins OmpC and PhoE of *Escherichia coli* as specific cell-surface targets of human lactoferrin. Binding characteristics and biological effects, *J Biol Chem* **274**, 16107-16114.
40. Ellison III RT & Giehl TJ (1991) Killing of gram-negative bacteria by lactoferrin and lysozyme, *J Clin Invest* **88**, 1080-1091.
41. Ellison III RT, Giehl TJ & La FF (1988) Damage of the outer membrane of enteric gram-negative bacteria by lactoferrin and transferrin, *Infect Immun* **56**, 2774-2781.
42. de Araujo AN & Giugliano LG (2001) Lactoferrin and free secretory component of human milk inhibit the adhesion of enteropathogenic *Escherichia coli* to HeLa cells, *BMC Microbiol* **1**, 25.

43. Giugliano LG, Ribeiro ST, Vainstein MH & Ulhoa CJ (1995) Free secretory component and lactoferrin of human milk inhibit the adhesion of enterotoxigenic *Escherichia coli*, *J Med Microbiol* **42**, 3-9.
44. Willer Eda M, Lima Rde L & Giugliano LG (2004) In vitro adhesion and invasion inhibition of *Shigella dysenteriae*, *Shigella flexneri* and *Shigella sonnei* clinical strains by human milk proteins, *BMC Microbiol* **4**, 18.
45. Antonini G, Catania MR, Greco R, Longhi C, Pisciotta MG, Seganti L & P. V (1997) Anti-invasive activity of bovine lactoferrin towards *Listeria monocytogenes*, *J Food Protec* **60**, 1-5.
46. Hasegawa K, Motsuchi W, Tanaka S & Dosako S (1994) Inhibition with lactoferrin of in vitro infection with human herpes virus, *Jpn J Med Sci Biol* **47**, 73-85.
47. Harmsen MC, Swart PJ, de Bethune MP, Pauwels R, De Clercq E, The TH & Meijer DK (1995) Antiviral effects of plasma and milk proteins: lactoferrin shows potent activity against both human immunodeficiency virus and human cytomegalovirus replication in vitro, *J Infect Dis* **172**, 380-388.
48. Hara K, Ikeda M, Saito S, Matsumoto S, Numata K, Kato N, Tanaka K & Sekihara H (2002) Lactoferrin inhibits hepatitis B virus infection in cultured human hepatocytes, *Hepatol Res* **24**, 228.
49. Ikeda M, Sugiyama K, Tanaka T, Tanaka K, Sekihara H, Shimotohno K & Kato N (1998) Lactoferrin markedly inhibits hepatitis C virus infection in cultured human hepatocytes, *Biochem Biophys Res Commun* **245**, 549-553.
50. Ochoa TJ, Noguera-Obenza M, Ebel F, Guzman CA, Gomez HF & Cleary TG (2003) Lactoferrin impairs type III secretory system function in enteropathogenic *Escherichia coli*, *Infect Immun* **71**, 5149-5155.
51. Gomez HF, Ochoa TJ, Carlin LG & Cleary TG (2003) Human lactoferrin impairs virulence of *Shigella flexneri*, *J Infect Dis* **187**, 87-95.
52. Lee HY, Park JH, Seok SH, Baek MW, Kim DJ, Lee BH, Kang PD, Kim YS & Park JH (2005) Potential antimicrobial effects of human lactoferrin against oral infection with *Listeria monocytogenes* in mice, *J Med Microbiol* **54**, 1049-1054.
53. Edde L, Hipolito RB, Hwang FF, Headon DR, Shalwitz RA & Sherman MP (2001) Lactoferrin protects neonatal rats from gut-related systemic infection, *Am J Physiol Gastrointest Liver Physiol* **281**, G1140-1150.
54. Bhimani RS, Vendrov Y & Furmanski P (1999) Influence of lactoferrin feeding and injection against systemic staphylococcal infections in mice, *J Appl Microbiol* **86**, 135-44.
55. Wakabayashi H, Kurokawa M, Shin K, Teraguchi S, Tamura Y & Shiraki K (2004) Oral lactoferrin prevents body weight loss and increases cytokine responses during herpes simplex virus type 1 infection of mice, *Biosci Biotechnol Biochem* **68**, 537-44.
56. Shin K, Wakabayashi H, Yamauchi K, Teraguchi S, Tamura Y, Kurokawa M & Shiraki K (2005) Effects of orally administered bovine lactoferrin and lactoperoxidase on influenza virus infection in mice, *J Med Microbiol* **54**, 717-723.
57. Takakura N, Wakabayashi H, Ishibashi H, Teraguchi S, Tamura Y, Yamaguchi H & Abe S (2003) Oral lactoferrin treatment of experimental oral candidiasis in mice, *Antimicrob Agents Chemother* **47**, 2619-2623.
58. Aruoma OI & Halliwell B (1987) Superoxide-dependent and ascorbate-dependent formation of hydroxyl radicals from hydrogen peroxide in the presence of iron. Are lactoferrin and transferrin promoters of hydroxyl-radical generation? *Biochem J* **241**, 273-278.
59. Elrod KC, Moore WR, Abraham WM & Tanaka RD (1997) Lactoferrin, a potent tryptase inhibitor, abolishes late-phase airway responses in allergic sheep, *Am J Respir Crit Care Med* **156**, 375-381.

60. Kruzel ML, Bacsı A, Choudhury B, Sur S & Boldogh I (2006) Lactoferrin decreases pollen antigen-induced allergic airway inflammation in a murine model of asthma, *Immunology* **119**, 159-166.
61. Guillen C, McInnes IB, Vaughan D, Speekenbrink AB & Brock JH (2000) The effects of local administration of lactoferrin on inflammation in murine autoimmune and infectious arthritis, *Arthritis Rheum* **43**, 2073-2080.
62. Levin J, van Deventer SJH, van der Poll T & Sturk A. (1994) Bacterial endotoxins. Basic science to anti-sepsis strategies, *Progress in Clinical and Biological Research*, **388**, John Wiley & Sons, Inc.
63. Ellass-Rochard E, Roseanu A, Legrand D, Trif M, Salmon V, Motas C, Montreuil J & Spik G (1995) Lactoferrin-lipopolysaccharide interaction: involvement of the 28-34 loop region of human lactoferrin in the high-affinity binding to Escherichia coli 055B5 lipopolysaccharide, *Biochem J* **312**, 839-845.
64. Ellass-Rochard E, Legrand D, Salmon V, Roseanu A, Trif M, Tobias PS, Mazurier J & Spik G (1998) Lactoferrin inhibits the endotoxin interaction with CD14 by competition with the lipopolysaccharide-binding protein, *Infect Immun* **66**, 486-491.
65. Baveye S, Ellass E, Fernig DG, Blanquart C, Mazurier J & Legrand D (2000) Human lactoferrin interacts with soluble CD14 and inhibits expression of endothelial adhesion molecules, E-selectin and ICAM-1, induced by the CD14-lipopolysaccharide complex, *Infect Immun* **68**, 6519-6525.
66. Lee WJ, Farmer JL, Hilty M & Kim YB (1998) The protective effects of lactoferrin feeding against endotoxin lethal shock in germfree piglets, *Infect Immun* **66**, 1421-1426.
67. Kruzel ML, Harari Y, Chen CY & Castro GA (2000) Lactoferrin protects gut mucosal integrity during endotoxemia induced by lipopolysaccharide in mice, *Inflammation* **24**, 33-44.
68. Kruzel ML, Harari Y, Mailman D, Actor JK & Zimecki M (2002) Differential effects of prophylactic, concurrent and therapeutic lactoferrin treatment on LPS-induced inflammatory responses in mice, *Clin Exp Immunol* **130**, 25-31.
69. Legrand D, Ellass E, Carpentier M & Mazurier J (2005) Lactoferrin: a modulator of immune and inflammatory responses, *Cell Mol Life Sci* **62**, 2549-2559.
70. Bezault J, Bhimani R, Wiprovnick J & Furmanski P (1994) Human lactoferrin inhibits growth of solid tumors and development of experimental metastases in mice, *Cancer Res* **54**, 2310-2312.
71. Yoo YC, Watanabe S, Watanabe R, Hata K, Shimazaki K & Azuma I (1997) Bovine lactoferrin and lactoferricin, a peptide derived from bovine lactoferrin, inhibit tumor metastasis in mice, *Jpn J Cancer Res* **88**, 184-90.
72. Varadhachary A, Wolf JS, Petrak K, O'Malley BW, Jr., Spadaro M, Curcio C, Forni G & Pericle F (2004) Oral lactoferrin inhibits growth of established tumors and potentiates conventional chemotherapy, *Int J Cancer* **111**, 398-403.
73. Tsuda H, Sekine K, Fujita K & Ligo M (2002) Cancer prevention by bovine lactoferrin and underlying mechanisms--a review of experimental and clinical studies, *Biochem Cell Biol* **80**, 131-136.
74. Wolf JS, Li D, Taylor RJ & O'Malley BW, Jr. (2003) Lactoferrin inhibits growth of malignant tumors of the head and neck, *ORL J Otorhinolaryngol Relat Spec* **65**, 245-249.
75. Hayes TG, Falchook GF, Varadhachary GR, Smith DP, Davis LD, Dhingra HM, Hayes BP & Varadhachary A (2006) Phase I trial of oral talactoferrin alfa in refractory solid tumors, *Invest New Drugs* **24**, 233-240.
76. Petrak K, Varadhachary A, NSCLC Clinical Investigator Group, Yankee E & Wang Y (2005) Double-blind controlled trial of oral Talactoferrin in combination therapy for first-line non-small cell lung cancer (NSCLC), *7th International Conference on Lactoferrin: Structure, Function and Applications*, Honolulu, Hawaii (October 16-19, 2005), 33.

77. Britigan BE, Lewis TS, Waldschmidt M, McCormick ML & Krieg AM (2001) Lactoferrin binds CpG-containing oligonucleotides and inhibits their immunostimulatory effects on human B cells, *J Immunol* **167**, 2921-2928.
78. Oh SM, Pyo CW, Kim Y & Choi SY (2004) Neutrophil lactoferrin upregulates the human p53 gene through induction of NF-kappaB activation cascade, *Oncogene* **23**, 8282-8291.
79. Oh SM, Hahn DH, Kim IH & Choi SY (2001) Human neutrophil lactoferrin trans-activates the matrix metalloproteinase 1 gene through stress-activated MAPK signaling modules, *J Biol Chem* **276**, 42575-42579.
80. Dhennin-Duthille I, Masson M, Damiens E, Fillebeen C, Spik G & Mazurier J (2000) Lactoferrin upregulates the expression of CD4 antigen through the stimulation of the mitogen-activated protein kinase in the human lymphoblastic T Jurkat cell line, *J Cell Biochem* **79**, 583-593.
81. Haversen L, Ohlsson BG, Hahn-Zoric M, Hanson LA & Mattsby-Baltzer I (2002) Lactoferrin down-regulates the LPS-induced cytokine production in monocytic cells via NF-kappa B, *Cell Immunol* **220**, 83-95.
82. Birgens HS, Hansen NE, Karle H & Kristensen LO (1983) Receptor binding of lactoferrin by human monocytes, *Br J Haematol* **54**, 383-391.
83. Mazurier J, Legrand D, Hu WL, Montreuil J & Spik G (1989) Expression of human lactotransferrin receptors in phytohemagglutinin-stimulated human peripheral blood lymphocytes. Isolation of the receptors by antiligand-affinity chromatography, *Eur J Biochem* **179**, 481-487.
84. Suzuki YA, Shin K & Lönnerdal B (2001) Molecular cloning and functional expression of a human intestinal lactoferrin receptor, *Biochemistry* **40**, 15771-15779.
85. Nichols BL, McKee KS, Henry JF & Putman M (1987) Human lactoferrin stimulates thymidine incorporation into DNA of rat crypt cells, *Pediatr Res* **21**, 563-567.
86. Zhang P, Sawicki V, Lewis A, Hanson L, Nuijens JH & Neville MC (2001) Human lactoferrin in the milk of transgenic mice increases intestinal growth in ten-day-old suckling neonates, *Adv Exp Med Biol* **501**, 107-113.
87. Togawa J, Nagase H, Tanaka K, Inamori M, Nakajima A, Ueno N, Saito T & Sekihara H (2002) Oral administration of lactoferrin reduces colitis in rats via modulation of the immune system and correction of cytokine imbalance, *J Gastroenterol Hepatol* **17**, 1291-1298.
88. Dial EJ, Dohrman AJ, Romero JJ & Lichtenberger LM (2005) Recombinant human lactoferrin prevents NSAID-induced intestinal bleeding in rodents, *J Pharm Pharmacol* **57**, 93-99.
89. Troost FJ, Saris WH & Brummer RJ (2003) Recombinant human lactoferrin ingestion attenuates indomethacin-induced enteropathy in vivo in healthy volunteers, *Eur J Clin Nutr* **57**, 1579-1585.
90. Shimmura S, Suematsu M, Shimoyama M, Tsubota K, Oguchi Y & Ishimura Y (1996) Subthreshold UV radiation-induced peroxide formation in cultured corneal epithelial cells: the protective effects of lactoferrin, *Exp Eye Res* **63**, 519-526.
91. Fujihara T, Nagano T, Endo K, Nakamura M & Nakata K (2000) Lactoferrin protects against UV-B irradiation-induced corneal epithelial damage in rats, *Cornea* **19**, 207-211.
92. Wu HF, Lundblad RL & Church FC (1995) Neutralization of heparin activity by neutrophil lactoferrin, *Blood* **85**, 421-428.
93. Stowell KM, Rado TA, Funk WD & Tweedie JW (1991) Expression of cloned human lactoferrin in baby-hamster kidney cells, *Biochem J* **276**, 349-355.
94. Ward PP, Lo J, Duke M, May GS, Headon DR & Conneely OM (1992) Production of biologically active recombinant human lactoferrin in *Aspergillus oryzae*, *Bio/Technology* **10**, 784-789.
95. Liang Q & Richardson T (1993) Expression and characterization of human lactoferrin in yeast *Saccharomyces cerevisiae*, *J Agric Food Chem* **41**, 1800-1807.

96. Salmon V, Legrand D, Georges B, Slomianny MC, Coddeville B & Spik G (1997) Characterization of human lactoferrin produced in the baculovirus expression system, *Protein Expr Purif* **9**, 203-210.
97. Chong DK & Langridge WH (2000) Expression of full-length bioactive antimicrobial human lactoferrin in potato plants, *Transgenic Res* **9**, 71-78.
98. Salmon V, Legrand D, Slomianny MC, el Yazidi I, Spik G, Gruber V, Bournat P, Olganier B, Mison D, Theisen M & Merot B (1998) Production of human lactoferrin in transgenic tobacco plants, *Protein Expr Purif* **13**, 127-135.
99. Li L, Shen W, Min L, Dong H, Sun Y & Pan Q (2006) Human lactoferrin transgenic rabbits produced efficiently using dimethylsulfoxide-sperm-mediated gene transfer, *Reprod Fertil Dev* **18**, 689-695.
100. Liu T, Zhang YZ & Wu XF (2005) High level expression of functionally active human lactoferrin in silkworm larvae, *J Biotechnol* **118**, 246-256.
101. Choi SM, Lee OS, Kwon SY, Kwak SS, Yu DY & Lee HS (2003) High expression of a human lactoferrin in transgenic tobacco cell cultures, *Biotechnol Lett* **25**, 213-218.
102. Kwon SY, Jo SH, Lee OS, Choi SM, Kwak SS & Lee HS (2003) Transgenic ginseng cell lines that produce high levels of a human lactoferrin, *Planta Med* **69**, 1005-1008.
103. Suzuki YA, Kelleher SL, Yalda D, Wu L, Huang J, Huang N & Lönnerdal B (2003) Expression, characterization, and biologic activity of recombinant human lactoferrin in rice, *J Pediatr Gastroenterol Nutr* **36**, 190-199.
104. Ward PP, Piddington CS, Cunningham GA, Zhou X, Wyatt RD & Conneely OM (1995) A system for the production of commercial quantities of human lactoferrin: a broad spectrum natural antibiotic, *Bio/Technology* **13**, 498-503.
105. Nuijens JH, van Berkel PH, Geerts ME, Hartevelt PP, de Boer HA, van Veen HA & Pieper FR (1997) Characterization of recombinant human lactoferrin secreted in milk of transgenic mice, *J Biol Chem* **272**, 8802-8807.
106. Nandi S, Suzuki YA, Huang J, Yalda D, Pham P, Wu L, G. B, Huang N & Lönnerdal B (2002) Expression of human lactoferrin in transgenic rice grains for the application in infant formula, *Plant Science* **163**, 713-722.
107. James DC, Freedman RB, Hoare M, Ogonah Ow, Rooney BC, Larionov OA, Dobrovolsky VN, Lagutin OV & Jenkins N (1995) N-glycosylation of recombinant human interferin-gamma produced in different animal expression systems, *Bio/Technology* **13**, 592-596.
108. Opdenakker G, Rudd PM, Ponting CP & Dwek RA (1993) Concepts and principles of glycobiology, *FASEB J* **7**, 1330-1337.
109. Jenkins N & Curling EM (1994) Glycosylation of recombinant proteins: problems and prospects, *Enzyme Microb Technol* **16**, 354-364.
110. van Ree R, Cabanes-Macheteau M, Akkerdaas J, Milazzo JP, Loutelier-Bourhis C, Rayon C, Villalba M, Koppelman S, Aalberse R, Rodriguez R, Faye L & Lerouge P (2000) Beta(1,2)-xylose and alpha(1,3)-fucose residues have a strong contribution in IgE binding to plant glycoallergens, *J Biol Chem* **275**, 11451-11458.
111. Dyck MK, Lacroix D, Pothier F & Sirard MA (2003) Making recombinant proteins in animals--different systems, different applications, *Trends Biotechnol* **21**, 394-399.
112. Houdebine LM (2002) Antibody manufacture in transgenic animals and comparisons with other systems, *Curr Opin Biotechnol* **13**, 625-9.
113. Krimpenfort P, Rademakers A, Eyestone W, van der Schans A, van der Broek S, Kooiman P, Kootwijk E, Platenburg G, Pieper F, Strijker R & de Boer HA (1991) Generation of transgenic dairy cattle using 'in vitro' embryo production, *Bio/Technology* **9**, 844-847.

Chapter 2

Analytical cation-exchange chromatography to assess the identity, purity, and N-terminal integrity of human lactoferrin

Harrie A. van Veen,* Marlieke E.J. Geerts, Patrick H.C. van Berkel, and Jan H. Nuijens

Pharming, Archimedesweg 4, 2333 CN Leiden, The Netherlands

Received 5 March 2002

Abstract

Human lactoferrin (hLF) is an iron-binding glycoprotein involved in the innate host defense. The positively charged N-terminal domain of hLF mediates several of its activities by interacting with ligands such as bacterial lipopolysaccharide (LPS), specific receptors, and other proteins. This cationic domain is highly susceptible to limited proteolysis, which impacts on the affinity of hLF for the ligand. An analytical method, employing cation-exchange chromatography on Mono S, was developed to assess the N-terminal integrity of hLF preparations. The method, which separates N-terminally intact hLF from hLF species lacking two (Gly¹-Arg²) or three (Gly¹-Arg²-Arg³) residues, showed that 5–58% of total hLF in commercially obtained preparations was N-terminally degraded. The elution profile of hLF on Mono S unequivocally differed from lactoferrins from other species as well as homologous and other whey proteins. Analysis of fresh human whey samples revealed two variants of N-terminally intact hLF, but not limitedly proteolyzed hLF. Mono S chromatography of 2 out of 26 individual human whey samples showed a rare polymorphic hLF variant with three N-terminal arginines (Gly¹-Arg²-Arg³-Arg⁴-Ser⁵-) instead of the usual variant with four N-terminal arginines (Gly¹-Arg²-Arg³-Arg⁴-Arg⁵-Ser⁶-). In conclusion, Mono S cation-exchange chromatography appeared a robust method to assess the identity, purity, N-terminal integrity, and the presence of polymorphic and intact hLF variants.

Keywords: Lactoferrin; N-terminal integrity; Mono S

Human lactoferrin (hLF)¹ is a metal-binding glycoprotein of M_r 77,000 that belongs to the transferrin family [1]. The molecule is found in milk, tears, saliva, and other secretions [2]. It is also present in the secondary granules of neutrophils [2]. Lactoferrin (LF) consists of a single polypeptide chain that is folded in two highly homologous lobes, designated the N- and C-lobe, each of which can bind a single ferric ion concomitantly with one bicarbonate anion [3]. The amino acid sequence of hLF has been determined and showed 69, 71, and 70% homology with bovine, porcine, and

murine lactoferrin, respectively [4–6]. Extensive in vitro and some in vivo studies revealed that hLF is involved in the host defense against infection and severe inflammation, most notably at the mucosal surface [2]. Antimicrobial activities of hLF include bacteriostasis by sequestration of free iron [7] and bactericidal activity by destabilization of cell-wall components [8,9]. Anti-inflammatory actions of hLF include inhibition of complement activation [10] and cytokine production [11] as well as binding to lipopolysaccharide (LPS) [12]. Many of the hLF activities are mediated by its positively charged N-terminus in which two basic clusters, i.e., Arg²-Arg³-Arg⁴-Arg⁵, and Arg²⁸-Lys²⁹-Val³⁰-Arg³¹, are juxtaposed to form a cationic cradle [13–15]. This domain binds to negatively charged ligands like LPS, DNA, and heparin [13–15], and other proteins such as lysozyme [13] as well as to specific receptors [16,17]. Several reports have indicated that the affinity of these interactions changes when consecutive arginines of the first basic cluster are removed by limited proteolysis or

* Corresponding author. Present address: Pharming, P.O. Box 451, 2300 AL Leiden, The Netherlands. Fax: +31-71-524-7494.

E-mail address: h.veen@pharming.com (H.A. van Veen).

¹ *Abbreviations used:* LF, lactoferrin; hLF, human LF; milk-purified hLF, S Sepharose human milk-purified LF; LPS, lipopolysaccharide; bLF, bovine LF; RT-PCR, reverse transcriptase-polymerase chain reaction; SDS-PAGE, sodium dodecyl sulfate-polyacrylamide gel electrophoresis.

site-directed mutagenesis [13,16–18]. Although gel electrophoretic studies indicated that the hLF molecule is highly resistant to degradation by trypsin and chymotrypsin [19], its first basic cluster is highly susceptible to tryptic proteolysis [16]. Therefore, a simple and robust analytical method to assess the N-terminal integrity of hLF from human or recombinant sources would be of great value in structure–function relationship studies. Here we report that analytical cation-exchange chromatography on Mono S [20], a mono-dispersed 10 μ m bead packed in a HR 5/5 column meets these criteria. In addition, Mono S chromatography appeared valuable for determining the identity and purity of hLF due to its unique elution profile.

Materials and methods

Reagents

Human lactoferrin and transferrin were obtained from Sigma Chemical (St. Louis, MO), Calbiochem (La Jolla, CA) and Serva (Heidelberg, Germany) or purified as described below. Neuraminidase was obtained from Behringwerke AG (Marburg, Germany). S Sepharose fast flow was obtained from Amersham Pharmacia Biotech (Uppsala, Sweden). Chemicals were of pro analysis grade or higher and buffers were filtered over 0.22- μ m filter (Millipore, Bedford, MA) prior to use.

Analytical cation-exchange chromatography of purified proteins

A Mono S HR 5/5 column (Amersham Pharmacia Biotech) was equilibrated in 20 mM sodium phosphate, pH 7.5 (buffer A), using an Äkta Explorer 10 equipped with a 2-mm flowcell (Amersham Pharmacia Biotech). Purified proteins were diluted in buffer A, centrifuged for 5 min at 23,000g, and applied to the column. The column was subsequently washed with 5 ml of buffer A and bound proteins were eluted with a linear salt gradient from 0 to 1 M sodium chloride (NaCl) in 30 ml buffer A after which 5 ml of the 1 M NaCl buffer was applied. The flow rate was at 1.0 ml/min and absorbance was measured simultaneously at 214, 280, and 465 nm. The elution position of proteins was determined after alignment of the theoretical salt gradient with the UV signal. Integration of eluting peaks was done with the Unicorn software (Amersham Pharmacia Biotech).

Purification of polymorphic variants of hLF from human milk

Sequence analysis of cDNA available from GenBanks [21–27] as well as several individuals revealed that the hLF gene is polymorphic at three sites, i.e., at

position 11 (alanine or threonine), position 29 (arginine or lysine) or position 561 (aspartic acid or glutamic acid) in hLF. RT-PCR and restriction enzyme analysis on genomic DNA from individual milk donors was performed to identify their polymorphism at positions 11, 29, and 561.² Human LF was purified from the milk of selected individual donors and saturated with iron as described [20]. This reference also describes the purification of human lysozyme.

Purification of lactoferrins from milk of various species

Human, bovine, murine, and porcine milk to which NaCl had been added to 0.4 M final concentration was centrifuged at 10 °C for 60 min at 23,000g to separate fat and casein fractions from the whey. The whey was 5-fold diluted in buffer A, passed through a 0.22- μ m filter, and applied to analytical chromatography on Mono S as described above. Eluted fractions were subjected to SDS–PAGE and human, murine, and bovine LF were applied to N-terminal protein sequencing.

SDS–PAGE analysis

Reduced SDS–PAGE (4–20%) analysis was performed using Novex precast gels and buffers from Invitrogen (Paisly, UK). Prior to analysis samples were boiled for 2 min to achieve denaturation and concomitant iron release [20]. The electrophoresis conditions were as recommended by the manufacturer.

Results

Analytical Mono S analysis of human milk-purified LF

Human lactoferrin is highly cationic which allows binding of this protein to strong cation-exchange media such as S Sepharose even in the presence of 0.4 M NaCl at pH 7.5. At this ionic strength and pH, other human milk proteins and LPS do not bind to hLF or the cation-exchange matrix. Reduced SDS–PAGE analysis of S Sepharose human milk-purified LF (milk-purified hLF) revealed a homogenous preparation with an identical migration pattern as the preparation obtained from Sigma (Fig. 1, lanes 1 and 2). Analytical cation-exchange chromatography of milk-purified hLF on Mono S showed that 99% of the protein eluted at 0.68 M NaCl (Fig. 2) and that the elution profile obtained at 214 nm was similar to that at 280 nm. N-terminal protein sequencing of this preparation revealed a single sequence with an intact N-terminus. The hLF recovery from

² P.H. Nibbering, R. de Winter, L.A. van Berkel, E. Ravensbergen, M.M. Welling, J.T. van Dissel, J.H. Nuijens, and P.H.C. van Berkel (2001) Human lactoferrin: Polymorphisms and antibacterial activity, ICAAC, Chicago, September 22–25, 2001.

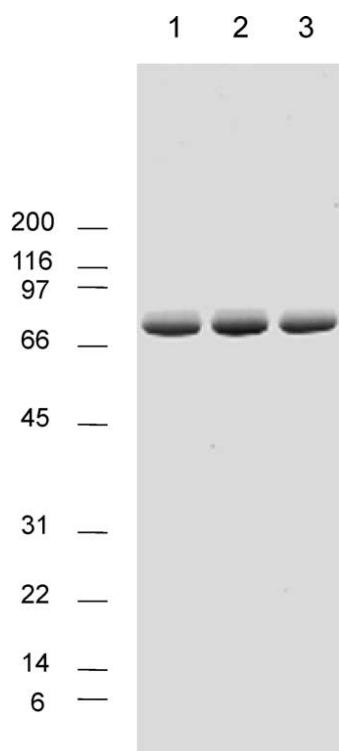

Fig. 1. SDS-PAGE analysis of purified hLF preparations. Commercially obtained hLF from Sigma (lane 1), S Sepharose-purified hLF from fresh human milk (lane 2), and hLF-fl (lane 3) were subjected to reduced SDS-PAGE (4–20%) analysis. Proteins, 2.5 µg/lane, were visualized with Coomassie brilliant blue. The migration of the standard protein markers is indicated on the left ($10^{-3} \times M_r$).

Mono S was $101 \pm 2\%$ on five separate experiments with 500 µg. Follow-up experiments with varying hLF quantities revealed linearity in recovery between 2.5 and 750 µg. Mono S analysis of fully iron-saturated hLF showed no significant change in the elution profile when compared with milk-purified hLF, indicating that iron-saturation does not affect the binding to and elution of hLF from Mono S (Table 1). This result is in line with earlier observations of milk-purified hLF and iron-saturated hLF binding equally well to anionic ligands [13], but conflicts with the results of Makino and Nishimura who reported different profiles of apo- and iron-saturated hLF on Mono S [28]. Absorption measurement at 465 nm, which allows specific detection of the iron-saturated conformation of lactoferrin [29], revealed that release of iron from hLF did not occur during Mono S analysis (H.A. van Veen, unpublished data). Analysis of desialylated and fully deglycosylated hLF showed no significant differences in retention on Mono S, indicating that the N-linked glycans of hLF are not involved in the binding to and elution from Mono S (Table 1, [20]).

LF species-specific elution profiles on Mono S

Analysis of the binding and elution from Mono S of molecules closely related in size and structure to hLF

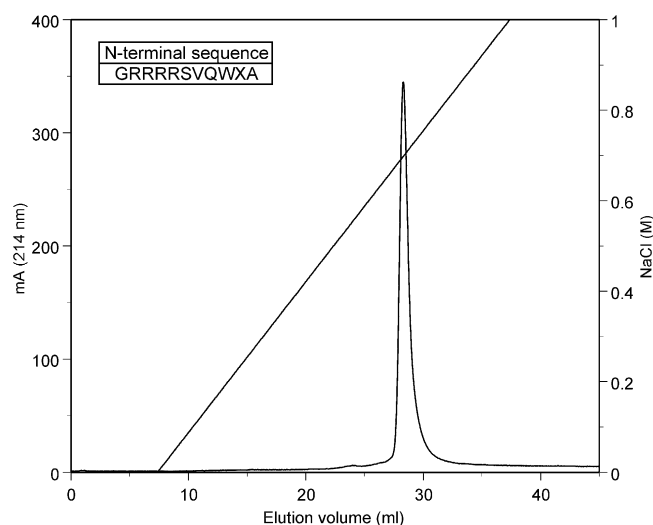

Fig. 2. Mono S chromatography and N-terminal protein sequencing of milk-purified hLF. One hundred micrograms of S Sepharose milk-purified hLF was applied to Mono S as described. The left and right abscissas give the absorption at 214 nm and NaCl concentration (M), respectively. The N-terminal protein sequencing result was obtained by the automatic Edman degradation procedure using an Applied Biosystems gas-phase sequencer, Model 473A. Sequencing results are presented by the standard one-letter code for amino acids.

revealed that human transferrin did not bind to the column, whereas heterologous LF species do, but elute at species-specific positions (Table 1). Bovine LF (bLF) eluted as a major peak at 0.80 M NaCl with a small shoulder at 0.76 M NaCl. Analysis of the latter, minor bLF variant revealed that it contains an N-linked glycan at Asn²⁸¹, whereas the major bLF variant eluting at 0.80 M NaCl is not glycosylated at this position.³ Hence, in contrast to hLF, N-linked glycosylation of bLF affects its elution from Mono S. The last peaks eluting from human and bovine whey (at 0.26 and 0.27 M NaCl) before the LF peaks represent human lysozyme and bovine lactoperoxidase, respectively.

Analysis of N-terminal integrity and purity of purified hLF preparations

Previously, we reported that consecutive removal of arginines from the first basic cluster of hLF, i.e., Arg²–Arg³–Arg⁴–Arg⁵, by limited proteolysis or site-directed mutagenesis affects the elution from Mono S [13,16,20]. Human LF in commercially purchased preparations may be limitedly proteolyzed. For example, Fig. 3 shows the Mono S analysis of the hLF preparation from Sigma, which appeared homogenous

³ H.A. van Veen, M.E.J. Geerts, J.P.J. Brakenhoff, P.H.C. van Berkel, and J.H. Nuijens (1997) N-glycosylation at Asn²⁸¹ in bovine lactoferrin protects the molecule against tryptic proteolysis. Third International Conference on Lactoferrin, Le Touquet, France, May 5–9, 1997.

Table 1
Species-specific elution of LFs and other (milk) proteins from Mono S

Protein ^a	N-terminal sequence	Elution ^b (M NaCl)
Milk-purified human LF	GRRRRSVQWXA	0.68
Iron-saturated human LF	—	0.67
Desialylated-human LF ^c	—	0.68
Human LF-Arg ²⁹	—	0.69
Human LF-Lys ²⁹	—	0.68
Bovine LF, major variant	APRKNVRWXT	0.80
Bovine LF, minor variant	APRKNVRWXT	0.76
Murine LF	KATTVRWXAV	0.26
Murine LF, polymorphic variant	KATTVQWXAV	0.22
Porcine LF	—	0.54
Human transferrin	—	No binding
Human lysozyme	—	0.26
Bovine lactoperoxidase	—	0.27

^a Purified proteins and whey from different species were subjected to analytical Mono S chromatography as described under Materials and methods.

^b The molarity of NaCl required to elute each protein.

^c Desialylated-human LF was obtained by incubation of 1 mU neuraminidase/μg hLF for 19 h at 37°C in 50 mM sodium acetate, pH 5.5, 1 mM calcium chloride.

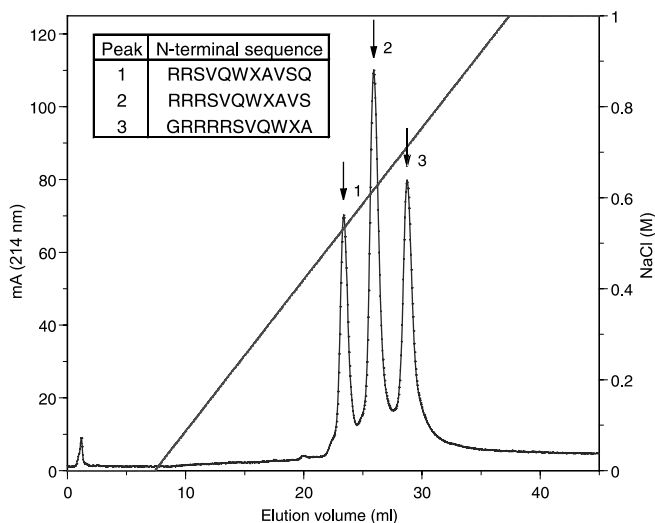

Fig. 3. Mono S chromatography and N-terminal protein sequencing of commercially obtained hLF. One hundred micrograms of Sigma hLF was subjected to Mono S analysis. Peak fractions (1–3) were applied to N-terminal protein sequencing.

on SDS-PAGE (Fig. 1, lane 1). It, nonetheless separated as three distinct peaks at 0.52, 0.61, and 0.69 M NaCl from Mono S. N-terminal protein sequencing revealed the subsequent peaks to represent hLF from which three or two N-terminal amino acids were lacking, and N-terminally intact hLF (Fig. 3). N-terminally intact hLF (peak 3) of the Sigma preparation eluted at the same position as hLF isolated from fresh human milk (Fig. 2). Analysis of six distinct hLF preparations from various commercial suppliers showed that each preparation contained N-terminally degraded hLF. The quantities of peak 1 and peak 2 material ranged from 1 to 19% and from 4 to 39%, respectively, whereas that of intact hLF ranged from 44 to 95% of total hLF. In one preparation

the quantity of intact hLF, decreased in favor of peak 2 (from 39 to 49%) and peak 1 (from 18 to 30%) after repeated freezing and thawing. In addition, Mono S analysis of one commercially obtained preparation, revealed a small amount of human lysozyme (see also Table 1). These results demonstrate the analytical power of analytical Mono S chromatography to assess the quality and purity of hLF preparations.

Analysis of hLF in human whey

The N-terminal integrity of hLF in the whey of 26 individual milk donors was determined by Mono S analysis. The whey samples were obtained after addition of 0.4 M NaCl to the milk to disrupt electrostatic interactions of hLF with casein micelles, and their removal by centrifugation. Fig. 4A shows the Mono S elution profile of whey from donor D with peaks eluting at 0.54 and 0.67 M NaCl. SDS-PAGE analysis of the peak at 0.54 M NaCl revealed an identical migration pattern as hLF from Sigma and milk-purified hLF (Fig. 1, lanes 1–3). N-terminal protein sequencing showed that the protein eluting at 0.54 M NaCl, designated hLF-fl, represented N-terminally intact hLF. Unexpectedly, when hLF-fl was subjected to rechromatography on Mono S, 65% of total hLF eluted at 0.69 M NaCl (Fig. 4B). As yet we do not understand the nature of this phenomenon. Control experiments with S Sepharose-purified hLF never did yield a hLF-fl peak on Mono S. We therefore speculate that a small whey component interacts with hLF to cause a decrease in the positive charge of the N-terminus. Apparently, this interaction is lost on rechromatography. Mono S analysis of whey samples from the panel of individual milk donors revealed the presence of hLF-fl in the whey of each donor at levels ranging from 4 to 31% of total hLF. In none of the

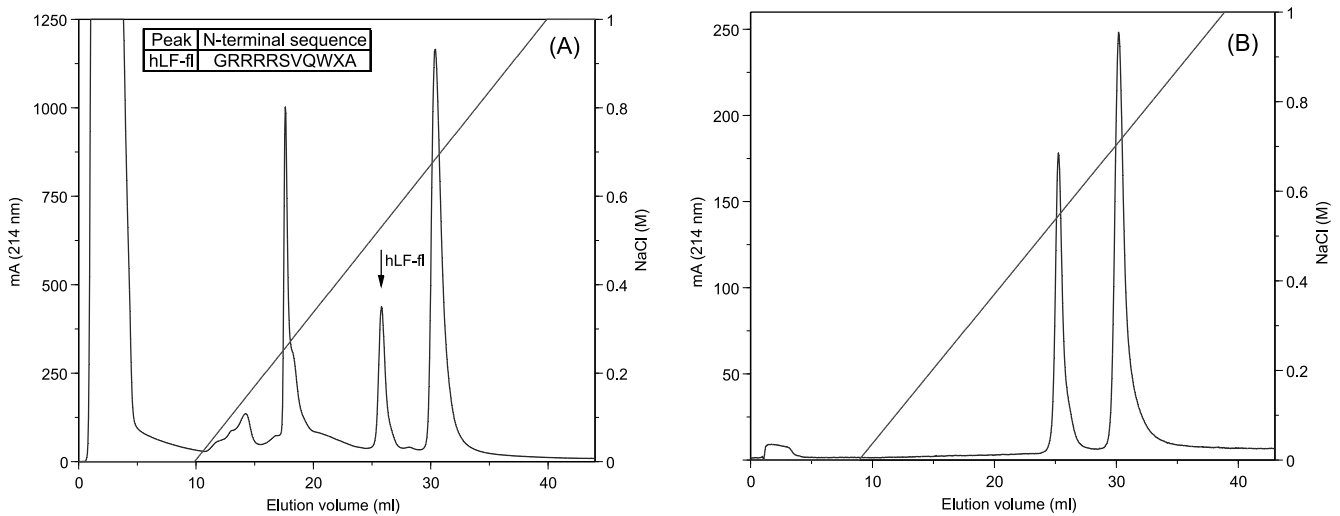

Fig. 4. Mono S analysis of human whey from donor D. Sodium chloride was added to milk from donor D to a final concentration of 0.4 M. The milk was subsequently centrifuged to separate whey from caseins and fat. Five-hundred microliters of whey was 5-fold diluted in buffer A and applied to Mono S. Nonbound proteins were removed by washing the column with 5 ml of buffer A and bound proteins were eluted with the linear salt gradient (A). The insert of panel A shows the result of N-terminal sequence analysis of hLF-fl. Panel B shows the rechromatography on Mono S of hLF-fl fractions that had been 2-fold diluted in buffer A and incubated for 7 h at 37°C.

wheys, N-terminal degradation to an extent exceeding of 1% of total hLF was observed.

Analysis of polymorphic hLF variants

Whey samples from 24 out of the 26 donors showed elution profiles very similar to that in Fig. 4A. Two whey samples displayed a different profile on Mono S (Fig. 5, donor V), with additional peaks eluting at 0.46 and 0.60 M NaCl, designated hLF-p. N-terminal sequencing of these peaks revealed an intact N-terminus with only three arginines, i.e., Gly¹-Arg²-Arg³-Arg⁴-

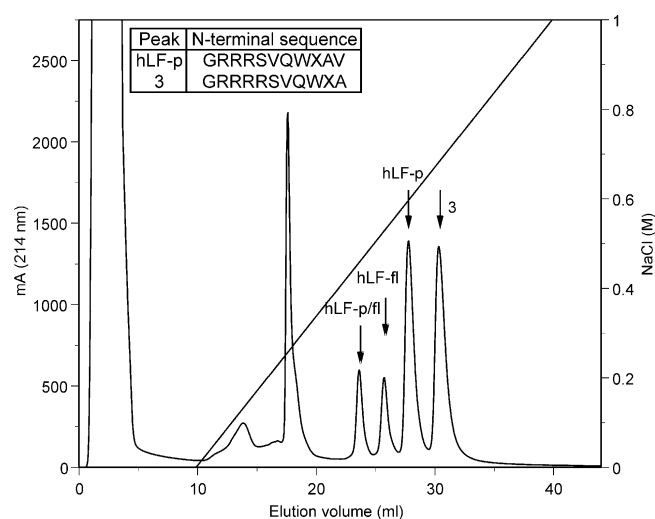

Fig. 5. Mono S analysis of human whey from donor V. Whey from donor V was subjected to Mono S analysis as described under Fig. 4. The insert shows the result of the N-terminal protein sequence analysis of hLF-p and peak 3 fractions.

Ser⁵-. The peak eluting at 0.46 M NaCl apparently represented the hLF-fl variant of the peak eluting at 0.60 M NaCl. The peak eluting at 0.67 M NaCl had the expected four N-terminal arginines. Thus these two donors express two polymorphic hLF variants, one with three and one with four N-terminal arginines. Peak integration revealed that the surface area of both peaks was similar, indicating that the two allelic variants of hLF were expressed at equal ratios.

Mono S analysis of hLF variants polymorphic at position 11 (alanine or threonine), position 29 (arginine or lysine; Table 1) or position 561 (aspartic acid or glutamic acid) did not reveal significant differences in the retention on Mono S. Hence, Mono S chromatography can only be used to detect polymorphism in the first basic cluster.

Reproducibility of hLF elution with different Mono S columns

Analysis of the ionic strength required to elute intact hLF from four different Mono S columns yielded highly reproducible results: the mean elution position of intact hLF from the various columns ranged between 0.67 and 0.70 M NaCl, with coefficients of variation ranging between 0.6 and 1.4% (at least 10 runs per column were performed over a period of at least 6 months).

We observed, however, that columns can retain small amounts of hLF that might elute in subsequent runs and that residual fat and casein micelles in whey preparations occasionally caused an increment in back pressure. Therefore, a protocol consisting of 25 ml of 1 M sodium hydroxide followed by 25 ml of 1% Tween 80 in 1 M acetic acid at a reversed flow rate of 0.5 ml/min was used on a regular basis to clean the column.

Discussion

This paper demonstrates that analytical cation-exchange chromatography on Mono S is a useful and reliable tool to study the identity, purity, and N-terminal integrity of hLF. Mono S fractionates hLF from other human (milk) proteins, between lactoferrins from distinct species, as well as between proteolytic, polymorphic, and milk-purified hLF variants. Mono S chromatography of hLF purified with S Sepharose from human milk to which 0.4 M NaCl had been added revealed a purity level exceeding 99% (Fig. 2). Similar purity levels were obtained on Mono S chromatography of recombinant hLF purified from the milk of transgenic cows. In addition, this analysis allows the quantification of bLF contaminating recombinant hLF, due to the distinct differences in species-specific elution profiles on this column (Table 1). We recommend the extraction of hLF from milk at high ionic strength as this procedure prevents the contamination of preparations with antibiotic proteins human lysozyme and bovine lactoperoxidase (Table 1) as well as with LPS. The high ionic strength disrupts the interaction of LF with these molecules and prevents their binding to the cation-exchange media. Contamination of (commercially obtained) LF preparations with these compounds may have blurred the interpretation of antibiotic and anti-inflammatory properties of lactoferrin in the literature. The N-terminus of hLF appeared to be highly susceptible to limited tryptic proteolysis resulting in the subsequent removal of two or three N-terminal amino acid residues [16]. We have shown previously that limited proteolysis of the N-terminus of hLF impacts on the antibiotic and anti-inflammatory activities of the protein [30]. It is shown in Fig. 3 that Mono S chromatography can be used to assess the extent of N-terminal proteolysis in hLF preparations. Limitedly proteolyzed hLF from which two or three N-terminal residues were lacking appeared to elute from Mono S at 0.52 and 0.61 M NaCl, respectively, whereas intact hLF eluted at 0.69 M NaCl. N-terminal proteolysis was present to a variable extent in all purchased hLF preparations, although most of the preparations appeared homogeneous and migrated as a doublet of protein bands of M_r 77,000 on non-reduced and reduced SDS-PAGE (Fig. 1, lane 1). One lot of hLF from commercial origin likely still contained the protease responsible for the degradation since the amount of peak 3, eluting at 0.69 M NaCl, decreased in time in favor of peak 2 and peak 1. We speculate that this protease is plasmin because of its presence in milk and its ability to bind to cation-exchange media [31]. Given the importance of the first basic cluster in hLF function [30] we advocate that the N-terminal integrity of hLF preparations is routinely assessed before and during *in vitro* or *in vivo* studies.

The Mono S profile of fresh whey samples of 24 individual human milk donors displayed a major peak representing N-terminally intact hLF eluting at 0.67 M

NaCl, and a variable amount of a minor peak, designated hLF-fl, eluting at 0.54 M NaCl (Fig. 4A). N-terminal protein sequencing revealed both these peaks to represent N-terminally intact hLF. In none of the whey samples, limited proteolysis of hLF was detected by chromatographic and protein sequence analysis. Re-running on Mono S of hLF-fl resulted in a minor hLF-fl peak and a major peak eluting at 0.69 M NaCl. Preliminary experiments have indicated that the ratio of hLF-fl versus intact hLF in whey and upon rechromatography is determined by the ionic strength and/or composition of the buffer, the temperature, and the incubation time. Thus, hLF-fl appears to represent a labile variant of intact hLF in whey, which on fractionation and re-running on Mono S transforms into the more cationic major variant of intact hLF (Fig. 4B). In contrast, we have never observed the appearance of hLF-fl on re-running of the more cationic variant of intact hLF. The presence of hLF-fl in human whey may relate to a specific conformation of the hLF N-terminus or to a reversible electrostatic and/or hydrophobic interaction with a small molecule present in the whey slightly decreasing the (exposed) positive charge. Phosphorylation at Ser⁵ in hLF-fl may offer an alternative explanation because the sequence –Arg²–Arg³–Arg⁴–Ser⁵–Val⁶– is recognized by a cA(G)MP-dependent protein kinase [32]. The mechanism of putative phosphate release upon rechromatography of hLF remains unclear. Large-scale purification of hLF using S Sepharose at high ionic strength yields N-terminally intact hLF preparations containing less than 1% of hLF-fl.

During the screening of human whey samples on Mono S, we found that 2 out of 26 individual donors appeared heterozygotes with one allele expressing N-terminal intact hLF with three N-terminal arginines next to the common hLF variant with four arginines (Fig. 5). The rare frequency of the polymorphic variant with three arginines in the Dutch population likely accounts for not having observed any individual being homozygous for this variant. The hLF polymorphism with three N-terminal arginines has been reported before [3,26] but it was debated whether it represented a true hLF polymorphism or an artifact related to cDNA production or sequencing error. The Mono S analysis and protein sequencing result prove that this polymorphic variant indeed exists. Obviously, Mono S chromatography can be used to further assess the occurrence and functional consequences of this hLF polymorphism. In contrast Mono S analysis cannot be used to discriminate between hLF polymorphic variants with either a lysine or an arginine at position 29 in the second basic cluster (Table 1).

Taken together, we show that Mono S analysis is a reliable tool to determine the purity, identity, N-terminal integrity, and presence of intact hLF variants in purified

hLF preparations. Hence, this robust method will be very useful in structure–function studies of hLF as well as a method to control and assure the quality of batches of recombinant hLF for applications in human health care.

Acknowledgments

We thank Richard de Winter and Wilfried Limpens for screening the milk donors. We thank Marianne Kroos (Erasmus University, Rotterdam, the Netherlands) for performing the N-terminal protein sequencing.

References

- [1] R.R. Crichton, Proteins of iron storage and transport, *Adv. Protein Chem.* 40 (1990) 281–363.
- [2] J.H. Nuijens, P.H.C. van Berkel, F.L. Schanbacher, Structure and biological actions of lactoferrin, *J. Mamm. Gland Biol. Neoplasia* 1 (1996) 285–295.
- [3] B.F. Anderson, H.M. Baker, G.E. Norris, D.W. Rice, E.N. Baker, Structure of human lactoferrin: crystallographic structure analysis and refinement at 2.8 Å resolution, *J. Mol. Biol.* 209 (1989) 711–734.
- [4] A. Pierce, D. Colavizza, M. Benaissa, P. Maes, A. Tartar, J. Montreuil, G. Spik, Molecular cloning and sequence analysis of bovine lactotransferrin, *Eur. J. Biochem.* 196 (1991) 177–184.
- [5] J.P. Lydon, B.R. O'Malley, O. Saucedo, T. Lee, D.R. Headon, O.M. Conneely, Nucleotide and primary amino acid sequence of porcine lactoferrin, *Biochim. Biophys. Acta* 1132 (1992) 97–99.
- [6] B.T. Pentecost, C.T. Teng, Lactotransferrin is the major estrogen inducible protein of mouse uterine secretions, *J. Biol. Chem.* 262 (1987) 10134–10139.
- [7] B. Reiter, J.H. Brock, E.D. Steel, Inhibition of *Escherichia coli* by bovine colostrum and post-colostral milk. II. The bacteriostatic effect of lactoferrin on a serum-susceptible and serum-resistant strain of *E. coli*, *Immunology* 28 (1975) 83–95.
- [8] R.T. Ellison III, T.J. Giehl, F.M. LaForce, Damage of the outer membrane of enteric gram-negative bacteria by lactoferrin and transferrin, *Infect. Immun.* 56 (1988) 2774–2781.
- [9] R.T. Ellison III, T.J. Giehl, Killing of gram-negative bacteria by lactoferrin and lysozyme, *J. Clin. Invest.* 88 (1991) 1080–1091.
- [10] A. Kijlstra, S.H.M. Jeurissen, Modulation of the classical C3 convertase of complement by tear lactoferrin, *Immunology* 47 (1982) 263–270.
- [11] J.R. Zucali, H.E. Broxmeyer, D. Levy, C. Morse, Lactoferrin decreases monocyte-induced fibroblast production of myeloid colony-stimulating activity by suppressing monocyte release of interleukin-1, *Blood* 74 (1989) 1531–1536.
- [12] B.J. Appelmelk, Y.Q. An, M. Geerts, B.G. Thijs, H.A. de Boer, D.M. MacLaren, J. de Graaff, J.H. Nuijens, Lactoferrin is a lipid A-binding protein, *Infect. Immun.* 62 (1994) 2628–2632.
- [13] P.H.C. van Berkel, M.E.J. Geerts, H.A. van Veen, M. Mericskay, H.A. de Boer, J.H. Nuijens, The N-terminal stretch Arg² Arg³, Arg⁴, and Arg⁵ of human lactoferrin is essential for binding to heparin, bacterial lipopolysaccharide, human lysozyme and DNA, *Biochem. J.* 328 (1997) 145–151.
- [14] D.M. Mann, E. Romm, M. Migliorini, Delineation of the glycosaminoglycan-binding site in the human inflammatory response protein lactoferrin, *J. Biol. Chem.* 269 (1994) 23661–23667.
- [15] H.F. Wu, D.M. Monroe, F.C. Church, Characterization of the glycosaminoglycan-binding region of lactoferrin, *Arch. Biochem. Biophys.* 317 (1995) 85–92.
- [16] D. Legrand, P.H.C. van Berkel, V. Salmon, H.A. van Veen, M.C. Slomianny, J.H. Nuijens, G. Spik, The N-terminal Arg², Arg³, and Arg⁴ of human lactoferrin interact with sulphated molecules but not with the receptor present on Jurkat human lymphoblastic T-cells, *Biochem. J.* 327 (1997) 841–846.
- [17] G.J. Ziere, M.K. Bijsterbosch, T.J. van Berkel, Removal of 14 N-terminal amino acids of lactoferrin enhances its affinity for parenchymal liver cells and potentiates the inhibition of β-very low density lipoprotein binding, *J. Biol. Chem.* 268 (1993) 27069–27075.
- [18] Y. El Yazidi-Belkoura, D. Legrand, J. Nuijens, M. Slomianny, P. van Berkel, G. Spik, The binding of lactoferrin to glycosaminoglycans on enterocyte-like HT29-18-C1 cells is mediated through basic residues located in the N-terminus, *Biochim. Biophys. Acta* 1568 (2001) 197–204.
- [19] R.D. Brines, J.H. Brock, The effect of trypsin and chymotrypsin on the in vitro antimicrobial and iron-binding properties of lactoferrin in human and bovine colostrum, *Biochim. Biophys. Acta* 759 (1983) 229–235.
- [20] P.H.C. van Berkel, M.E.J. Geerts, H.A. van Veen, P.M. Kooiman, F. Pieper, H.A. de Boer, J.H. Nuijens, Glycosylated and unglycosylated human lactoferrins can both bind iron and have identical affinities towards human lysozyme and bacterial lipopolysaccharide, but differ in their susceptibility towards tryptic proteolysis, *Biochem. J.* 312 (1995) 107–114.
- [21] T.J. Panella, Y.H. Liu, A.T. Huang, C.T. Teng, Polymorphism and altered methylation of the lactoferrin gene in normal leukocytes, leukemic cells, and breast cancer, *Cancer Res.* 51 (1991) 3037–3043.
- [22] M.J. Powell, J.E. Ogden, Nucleotide sequence of human lactoferrin cDNA, *Nucleic Acids Res.* 18 (1990) 4013.
- [23] Q. Liang, T. Richardson, Expression and characterization of human lactoferrin in yeast *Saccharomyces cerevisiae*, *J. Agric. Food Chem.* 41 (1993) 1800–1807.
- [24] M.W. Rey, S.L. Woloshuk, H.A. de Boer, F.R. Pieper, Complete nucleotide sequence of human mammary gland lactoferrin, *Nucleic Acids Res.* 18 (1990) 5288.
- [25] T.A. Rado, X.P. Wei, E.J. Benz, Isolation of lactoferrin cDNA from a human myeloid library and expression of mRNA during normal and leukemic myelopoiesis, *Blood* 70 (1987) 989–993.
- [26] K.M. Stowell, T.A. Rado, W.D. Funk, J.W. Tweedie, Expression of cloned human lactoferrin in baby-hamster kidney cells, *Biochem. J.* 276 (1991) 349–355.
- [27] P.P. Ward, J. Lo, M. Duke, G.S. May, D.R. Headon, O.M. Conneely, Production of biologically active recombinant human lactoferrin in *Aspergillus oryzae*, *Bio/Technology* 10 (1992) 784–789.
- [28] Y. Makino, S. Nishimura, High-performance liquid chromatographic separation of human apolactoferrin and monoferric and diferric lactoferrins, *J. Chromatogr.* 579 (1992) 346–349.
- [29] T.M. Cox, J. Mazurier, G. Spik, J. Montreuil, T.J. Peters, Iron binding proteins and influx of iron across the duodenal brush border, *Biochim. Biophys. Acta* 588 (1979) 120–128.
- [30] P.H. Nibbering, E. Ravensbergen, M.M. Welling, L.A. van Berkel, P.H.C. van Berkel, E.K.J. Pauwels, J.H. Nuijens, Human lactoferrin and peptides derived from its N-terminus are highly effective against infections with antibiotic resistant bacteria, *Infect. Immun.* 69 (2001) 1469–1476.
- [31] C. Benfeldt, L.B. Larsen, J.T. Rasmussen, P.A. Andreasen, T.E. Petersen, Isolation and characterization of plasminogen and plasmin from bovine milk, *Int. Dairy J.* 5 (1995) 577–592.
- [32] N. Blom, S. Gammeltoft, S. Brunak, Sequence and structure-based prediction of eukaryotic protein phosphorylation sites, *J. Mol. Biol.* 294 (1999) 1351–1362.

Chapter 3

Characterization of monoclonal antibodies against human lactoferrin

Patrick H.C. van Berkel¹, Harrie A. van Veen*, Marlieke E.J. Geerts, Jan H. Nuijens

Pharming, Archimedesweg 4, 2333 CN, PO Box 451, 2300 AL Leiden, The Netherlands

Received 23 November 2001; received in revised form 30 April 2002; accepted 2 May 2002

Abstract

The iron-binding glycoprotein human lactoferrin (hLF) is involved in the host defense against infection and is a modulator of inflammatory reactions. We generated monoclonal antibodies (mAbs) to hLF as tools to assist both structure–function studies and the development of recombinant human lactoferrin for applications in human health care. Binding experiments with ten distinct anti-hLF mAbs to tryptic and recombinant hLF fragments in ELISA and/or on immunoblots revealed that five mAbs bound to conformational epitopes residing in the N-lobe (residues 1 to 334), whereas the other five bound to C-lobe conformational epitopes (residues 335 to 692). None of the mAbs bound to hLF denatured upon reduction. Monoclonal antibody E11 appeared to bind to the arginine-rich N-terminus of hLF, which is the binding site for heparin, bacterial lipopolysaccharide, human lysozyme, DNA and receptors. The dissociation constant of the distinct mAbs for hLF ranged from 0.5 to 18 nM, without differences in affinity for unsaturated or iron-saturated hLF, indicating that the conformational changes subject to incorporation of iron do not seem to affect the exposure and/or conformation of the antibody epitopes. The mAbs did not bind to human transferrin, a protein closely related to hLF in size, primary amino acid sequence and structure. Two C-lobe specific mAbs, E2 and E8, cross-reacted with bovine and/or porcine lactoferrin, indicating that human, bovine and porcine lactoferrin share antigenic determinants. This panel of mAbs will be used to develop quantitative and qualitative immunoassays for hLF and to delineate which regions of hLF are relevant to its anti-infective and anti-inflammatory properties.

Keywords: Monoclonal antibodies; Human lactoferrin; Structure; Function

Abbreviations: bLF, bovine lactoferrin; hLF, human lactoferrin; hTF, human transferrin; K_d , dissociation constant; mAb, monoclonal antibody; pLF, porcine lactoferrin; Lfc, lactoferricin H, peptide comprising hLF residues Gly¹ to Ile⁴⁷.

* Corresponding author. Tel.: +31-71-5247190; fax: +31-71-5247494.

E-mail address: h.veen@pharming.com (H.A. van Veen).

¹ Current address: Crucell Holland BV, Archimedesweg 4, Leiden, The Netherlands.

1. Introduction

Lactoferrin is a glycoprotein of Mr 77 000, which belongs to the transferrin family (Crichton, 1990). Members of this family of iron-transporting proteins are widely distributed in the body fluids of vertebrates and invertebrates. Lactoferrin is present in milk and mucosal secretions as well as in the secondary granules of neutrophils. Human lactoferrin (hLF) consists of a polypeptide chain of 692 amino acids (Metz-Boutigue et al., 1984; Rey et al., 1990), folded into two globular lobes (Anderson et al., 1989), designated the N- and C-

lobe. These lobes share an amino acid homology of about 40%, suggesting that lactoferrin has evolved by gene duplication from an ancestral gene half its size (Crichton, 1990). There is substantial homology between distinct lactoferrin species. For example, bovine lactoferrin (bLF) shows 69% and 64% amino acid identity with human and murine lactoferrin, respectively (Pierce et al., 1991), whereas the amino acid sequence of porcine lactoferrin (pLF) shows 73%, 71% and 62% homology with bovine, human and murine lactoferrin (Lydon et al., 1992). The two lobes of lactoferrin are connected by a three-turn α -helix. Each lobe folds into α -helix and β -sheet arrays to form two domains per lobe. The domains, connected by a hinge region, create a deep iron-binding cleft within each lobe. One aspartate, two tyrosines, one histidine and a bicarbonate ion are involved in the binding of iron within this cleft (Anderson et al., 1989).

Based on the many reports of its antimicrobial and other properties, lactoferrin is thought to represent a component of the innate host defense (Nuijens et al., 1996). Its growth inhibiting activity towards microorganisms likely occurs via sequestration of free iron (Reiter et al., 1975). The bactericidal activity of lactoferrin towards certain bacteria (Arnold et al., 1977) is mediated through destabilization of the bacterial cell wall after binding to cell wall components, such as bacterial lipopolysaccharide (Ellison and Giehl, 1991; Nibbering et al., 2001). Less clear is the mechanism of the many in vitro anti-inflammatory properties of lactoferrin such as the inhibition of complement activation (Kijlstra and Jeurissen, 1982) and the inhibition of cytokine production (Crouch et al., 1992).

We generated monoclonal antibodies (mAbs) to hLF to serve as tools in studies of the regions of hLF that are involved in its antibacterial and anti-inflammatory activities. Here, we describe the generation, properties and provisional epitope mapping using proteolytic and recombinant hLF fragments of 10 distinct mAbs against hLF.

2. Materials and methods

2.1. Reagents

Human transferrin (hTF), bovine pancreatic trypsin (type III-S) and soybean trypsin inhibitor (SBTI)

were purchased from Sigma (St. Louis, MO, USA). Peroxidase labelled and unlabelled goat anti-mouse immunoglobulin, normal goat serum and recombinant IL-6 were from the Central Laboratory of the Netherlands Red Cross Blood Transfusion Service (CLB, Amsterdam, The Netherlands). Freund's adjuvant was from Cappel (Organon Teknika, Turnhout, Belgium). Polysorp immunoplates were from Nunc (Roskilde, Denmark). All cell culture reagents were from Gibco (Paisley, UK). ^{125}I was from Amersham Biosciences (Bergrand, The Netherlands) and Iodo-beads were from Perbio (Tattenhall, UK).

2.2. Purification of human, bovine and porcine lactoferrin

Human lactoferrin was isolated from fresh human milk, as previously described (van Berkel et al., 1995) and is further designated as 'natural hLF'. Bovine and porcine lactoferrin (bLF and pLF, respectively) were isolated from milk by cationic exchange chromatography using essentially the same procedure as for the isolation of natural hLF. Porcine lactoferrin and bLF were eluted from Mono S at 0.5 and 0.8 M NaCl, respectively (Nuijens and van Veen, 1998). Saturation of natural hLF with iron was performed as described (van Berkel et al., 1995). Saturation was complete as assessed by absorbance measurements of hLF in solution and upon non-reducing SDS-PAGE of non-boiled samples (Nuijens et al., 1997).

2.3. Cell culture

Sp2/0-Ag14 myeloma cells [ATCC CRL 1583] were cultured in Iscove's Modified Dulbecco's Medium supplemented with 5% fetal calf serum (FCS), 50 U/ml penicillin, 50 $\mu\text{g}/\text{ml}$ streptomycin and 0.0003% (v/v) β -mercaptoethanol. Hybridomas were cultured in the same medium further supplemented with 500 U/ml IL-6 and 0.1 mM hypoxanthine. CHO/DHFR⁻ cells [ATCC CRL 9096] were cultured in Dulbecco's Modified Eagle's Medium supplemented with 10% FCS, 50 U/ml penicillin, 50 $\mu\text{g}/\text{ml}$ streptomycin, 0.1 mM hypoxanthine and 10 μM thymidine. Cell cultures were maintained at 37 °C in a humidified CO₂/air (1:19) incubator.

2.4. Production and purification of anti-hLF monoclonal antibodies

BALB/c mice were immunized by intraperitoneal injection with 50 µg natural hLF and/or iron-saturated hLF in complete Freund's adjuvant and were boosted every 2 weeks with the same amount of antigen in incomplete adjuvant. Four days after the fourth injection, spleen cells were fused with Sp2/0-Ag14 myeloma cells. Fusion and hybridoma selection were done as previously described (Fazekas de St Groth and Scheidegger, 1980) except that dimethylsulfoxide was omitted from the polyethylene glycol solution and IL-6 at 500 U/ml was used during culture to promote cell proliferation. Culture supernatants were screened for the presence of specific anti-hLF antibodies by RIA and ELISA as described below. Hybridomas producing hLF-specific antibodies were cloned by repeated limiting dilution. Immunoglobulin-enriched fractions of culture supernatant were prepared by precipitation with ammonium sulphate. Precipitates were redissolved and dialyzed against 10 mM sodium phosphate, 0.15 M NaCl, pH 7.5 (PBS). Monoclonal antibodies were purified using the Repligen antibody purification kit (Cambridge, MA, USA). SDS-PAGE of 10 µg of these antibody preparations showed that they were at least 99% pure. The antibody concentration was determined by absorbance measurements at 280 nm, assuming an absorbance coefficient of 1.4 for a 0.1% (w/v) solution. Isotype determination of mAbs was done with the Mouse mAb Isotyping kit of Hycult Biotechnology BV (Uden, The Netherlands).

2.5. Hybridoma screening

2.5.1. RIA

Goat anti-mouse immunoglobulin antibody (30 µg) coupled to 1.5 mg Sepharose 4B in 250 µl PBS, 0.1% Tween-20, 0.05% sodium azide was added to 50 µl hybridoma supernatant and 50 µl ¹²⁵I-hLF and/or ¹²⁵I-Fe-hLF (approximately 35000 cpm in PBS, 0.1% Tween-20, 1% bovine serum albumin (van Berkel et al., 1995)). After incubation for 6 h, the Sepharose was washed and Sepharose-bound radioactivity was measured using a gamma-counter (LKB Bromma, Uppsala, Sweden).

2.5.2. ELISA

PBS containing 1 µg/ml purified natural hLF and/or iron-saturated hLF was incubated for 16 h at 20 °C in Polysorp plates. The plates were then washed with PBS, 0.02% Tween-20 and incubated for 3 h with hybridoma supernatant diluted two-fold in PTG (PBS, 0.02% (w/v) Tween-20, 0.2% (w/v) gelatin). After washing, PTG containing 3.5 µg/ml peroxidase labelled goat anti-mouse immunoglobulin and 1% (v/v) normal goat serum was added to each well. Plates were incubated for another hour, washed and substrate solution (0.01% (w/v) 3,3',5,5'-tetramethylbenzidine, 0.003% (v/v) H₂O₂ in 0.11 M sodium acetate, pH 5.5) was added. Substrate conversion was stopped by the addition of 2 M H₂SO₄ and the absorbance of converted substrate was measured at 450 nm with a SLT 340 ATCC microplate reader (SLT-labinstruments, Salzburg, Austria). All incubations were done in 100 µl volumes.

2.6. Expression and purification of the recombinant N- and C-lobe of hLF

A cDNA, encoding the N-lobe of hLF (residues Gly¹ to Lys³³⁴), was generated from pCMV/hLF (van Berkel et al., 1996) by mutagenesis via PCR. The 5' primer 5' G T C A A G C T T G A G G T G T G G - C A G G C T T G A 3' was complementary to the 5' sequence of the hybrid splice acceptor site (van Berkel et al., 1995). With the 3' primer, 5' GCTCTAGA-TCATTATTTCTTCAAGTTCTGGATGGCAGT 3', a *Xba*I restriction site (underlined) and the complement of two translational stop codons (boldface) were introduced. Using PCR, the 1.15-kb fragment was amplified. This PCR-mixture was used for TA-cloning into pCR/II (Invitrogen, San Diego, CA, USA). After isolation of the plasmid, the 1.15-kb fragment was excised by *Hind*III/*Xba*I and ligated into the expression vector pRc/CMV. The resulting plasmid was designated pCMV/rN.

The expression vector pCMV/rC encoding the connecting three-turn α-helix and the C-lobe of hLF (residues Ser³³⁵ to Lys⁶⁹²) was produced with the Transformer™ site-directed mutagenesis kit as described (van Berkel et al., 1996). The entire N-lobe was deleted with the mutagenic primer 5' CTG-TTGCTCTTGCCAGTGAGGAGGAAGTGG 3', which corresponded to the 14 last nucleotides of the

bovine αS_1 casein signal sequence (van Berkel et al., 1995; underlined) fused to nucleotides 1354 to 1369 of the hLF cDNA (boldface; van Berkel et al., 1996). After mutagenesis, the nature of the deletion was confirmed by dideoxy sequencing.

Human 293(S) [ATCC CRL 1573] cells constitutively expressing pCMV/rN or pCMV/rC were generated as described (van Berkel et al., 1996). Expression of the recombinant lobes was measured with the hLF-specific ELISA (van Berkel et al., 1996). The recombinant N-lobe was purified from the supernatant of 293(S) cells expressing pCMV/rN using S Sepharose (van Berkel et al., 1995). The supernatant of 293(S) cells expressing pCMV/rC was batch-wise incubated for 16 h with C-lobe specific anti-hLF monoclonal E19 (van Berkel et al., 1997) coupled to CNBr-activated Sepharose 4B. This was poured into a column and washed with PBS containing 1.0 M NaCl to remove a-specifically absorbed protein. Recombinant C-lobe was eluted with 0.1 M glycine, 0.15 M NaCl, pH 2.5. Eluted fractions of 500 μ l were immediately neutralized in 25 μ l 1.5 M Tris-HCl, pH 8.7.

2.7. Expression of lactoferricin H

The expression vector pCMV/lfc encoding lactoferricin H (residues Gly¹ to Ile⁴⁷; Bellamy et al., 1992) was generated from pCMV/hLF by PCR as described above for the recombinant N-lobe, except that 3' primer 5' TCATTAGATACTGGATGGGG-GAGTCTCT 3' was used. pCMV/lfc was transfected to CHO/DHFR⁻ as described (van Berkel et al., 1996). After transfection, 800 μ g/ml Geneticin was added to the culture medium to select for pCMV/lfc containing cells. Recombinant lactoferricin H was isolated from culture supernatant using S Sepharose as described for natural hLF (van Berkel et al., 1995).

2.8. Determination of dissociation constant

The antibody-antigen interaction constant, K_d , was determined according to Müller (1983). Briefly, Medium Binding plates (Costar, Cambridge, MA, USA) were incubated for 16 h at 20 °C with PBS containing 1–2 μ g/ml of purified mAb. Plates were washed with PBS, 0.02% Tween-20 and ¹²⁵I-hLF (approximately 2 ng per well; 35,000 cpm) was added in the presence or absence of competitor. All incuba-

tions were done in 100 μ l volumes. After 4 h at 20 °C, the plates were washed, the wells were snapped apart, placed into tubes and radioactivity was measured. The K_d was calculated as described by Müller (1983) using the equation:

$$K_d = ([I] - [T]) \times (1 - 1.5b + 0.5b^2)M$$

Where b is the fraction of the tracer (¹²⁵I-hLF) bound by the antibody in the absence of competitor, T is the total tracer concentration and I the competitor concentration at 50% inhibition of the tracer antibody binding.

2.9. Mapping of the anti-hLF antibody epitopes by ELISA and immunoblotting

Localization of the anti-hLF mAb binding sites to the N- and C-lobes was performed by ELISA as previously described (van Berkel et al., 1997). Briefly, Polysorp plates were coated with 100 μ l PBS containing 1 μ g/ml purified mAb. Plates were washed and incubated with serial dilutions of natural hLF or culture medium of 293(S) cells secreting either the recombinant N- or C-lobe. After washing, bound hLF was measured by adding peroxidase conjugated bovine anti-hLF. Non-reducing and reducing SDS-PAGE and immunoblotting were performed as previously described (van Berkel et al., 1995, 1996; Nuijens et al., 1997).

2.10. Partial trypsin digestion of human lactoferrin

Partial trypsin digestion of natural hLF was done in 50 mM Tris-HCl, 2 mM CaCl₂, pH 8.0 at 37 °C for 4 h with an enzyme to substrate ratio of 1:1. In preliminary experiments, we determined that after 4 h of digestion approximately 50% of the molecules had been cleaved into major cleavage products of Mr 39,000 and 51,000 (Legrand et al., 1986; Hutchens et al., 1991; van Berkel et al., 1995).

3. Results

3.1. Generation and characterization of anti-hLF monoclonal antibodies

Mice were immunized with natural hLF and/or iron-saturated hLF and the serum immune responses

were monitored by RIA and ELISA. Spleen cells were fused with Sp2/0 myeloma cells, resulting in 890 proliferating hybridomas. Anti-hLF producing hybridomas were selected as described in Materials and methods. After subcloning, 10 hybridomas showed stable anti-hLF production (Table 1). Heavy and light chain subclass determination showed that all mAbs were of the IgG1 type with a Kappa-light chain, except E10 (IgG2a, Table 1).

A RIA using radiolabeled hLF as a tracer was used to determine the dissociation constant (K_d) of purified anti-hLF mAbs for natural hLF (3% saturated) and fully iron-saturated hLF. The K_d of the various mAbs for natural hLF ranged from 0.5 to 18 nM (Table 1). The affinities of E2 and E8 for fluid-phase radiolabeled hLF appeared to be too low to yield significant binding of the tracer, which precluded the assessment of possible differences in affinity for natural and iron-saturated hLF. All other mAbs had about the same K_d for natural and iron-saturated hLF. This indicates that the exposure and/or conformation of these epitopes are not affected by the binding of iron.

3.2. Specificity of anti-human lactoferrin monoclonal antibodies

Human transferrin (hTF), bLF or pLF were immobilized onto microtiter plates and incubated with serial

dilutions of purified mAbs, to determine their specificity. None of the mAbs bound to hTF (not shown). Monoclonal antibody E2 bound to hLF and bLF but not to pLF, whereas E8 bound to all three lactoferrin species (Fig. 1). None of the other mAbs bound to bLF or pLF (Fig. 1 shows the representative results with E3). This indicates that human, bovine and porcine lactoferrin share at least one antigenic determinant, namely the one recognized by E8. Furthermore, hLF and bLF share the E2 epitope.

3.3. Epitope localization by antibody binding to fluid-phase recombinant hLF fragments

To assign the antibody epitopes to the N- or C-lobe, we added serial dilutions of culture supernatants containing either the recombinant N- or C-lobe to mAbs immobilized onto microtiter plates. Natural hLF was used as a positive control. Fig. 2 shows the dose–response curves with E13 and E17. Similar experiments were done with the other mAbs (Table 1). Four mAbs reacted with the N-lobe, but not with the C-lobe, whereas five mAbs bound to the C-lobe alone. Monoclonal antibody E1 bound to neither the recombinant N- nor the C-lobe.

3.4. Epitope localization by immunoblotting

Fig. 3 shows the result of immunoblotting with the distinct mAbs on purified natural hLF (Fig. 3A), recombinant N- (Fig. 3B) and C-lobe (Fig. 3C) as well as trypsinized hLF (Fig. 3D). The positive control, lane P, shows the binding of HRPO-labelled polyclonal bovine anti-hLF antibodies (van Berkel et al., 1995), whereas lane C shows the lack of binding of a control mAb against C1 esterase. All mAbs bound to non-reduced hLF (Fig. 3A), but not to reduced hLF (not shown), which indicates that the mAbs bind to conformational epitopes, which are apparently destroyed upon reduction of the protein.

Lane 1 shows that mAb E1 did not bind to the recombinant N-lobe nor the C-lobe (residues 1–334 and 335–692, respectively) confirming the ELISA data (Table 1). The weak binding of E1 to C1^{tryp} (residues 284–692 with one N-linked glycan chain, Mr of 51,000) suggests that residues on the C-terminal part of the hLF N-lobe contribute to the E1 epitope. Lane 2 shows that E2 did not bind to the recombinant

Table 1
Characterization of anti-human lactoferrin monoclonal antibodies

	Subclass	K_d (nM)		ELISA mapping	
		Natural hLF	Iron-saturated hLF	N-lobe	C-lobe
E1	IgG1, κ^a	18 ^b	18	– ^c	–
E2	IgG1, κ	– ^d	–	–	+
E3	IgG1, κ	3	3	+	–
E8	IgG1, κ	– ^d	–	+	+
E10	IgG2a, κ	1	0.5	–	+
E11	IgG1, κ	4	3	+	–
E13	IgG1, κ	3	3	–	+
E17	IgG1, κ	3	3	+	–
E19	IgG1, κ	3	4	–	+
E31	IgG1, κ	4	4	+	–

^a κ indicates a κ light-chain.

^b Dissociation constants (K_d) are given as the mean of two duplicate experiments.

^c No binding in ELISA.

^d No binding of ¹²⁵I-hLF.

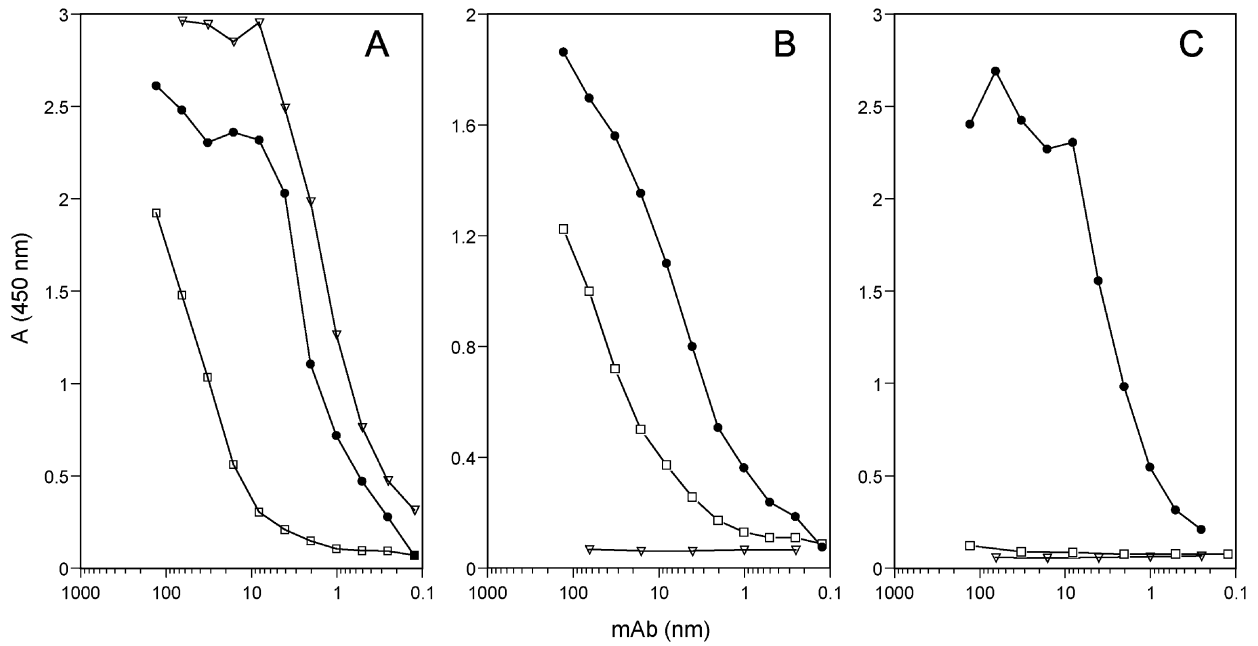

Fig. 1. Binding of mAbs E2, E3 and E8 to human, bovine and porcine lactoferrin. Polysorp plates were coated with 100 μ l of 1 μ g/ml hLF (A), bLF (B) or pLF (C) in PBS and incubated with serial dilutions of E2 (\square), E8 (\bullet) and E3 (∇). Bound mAb was detected by incubation with peroxidase labelled goat anti-mouse immunoglobulin. The A_{450} values of converted substrate are plotted against the amount of mAb added.

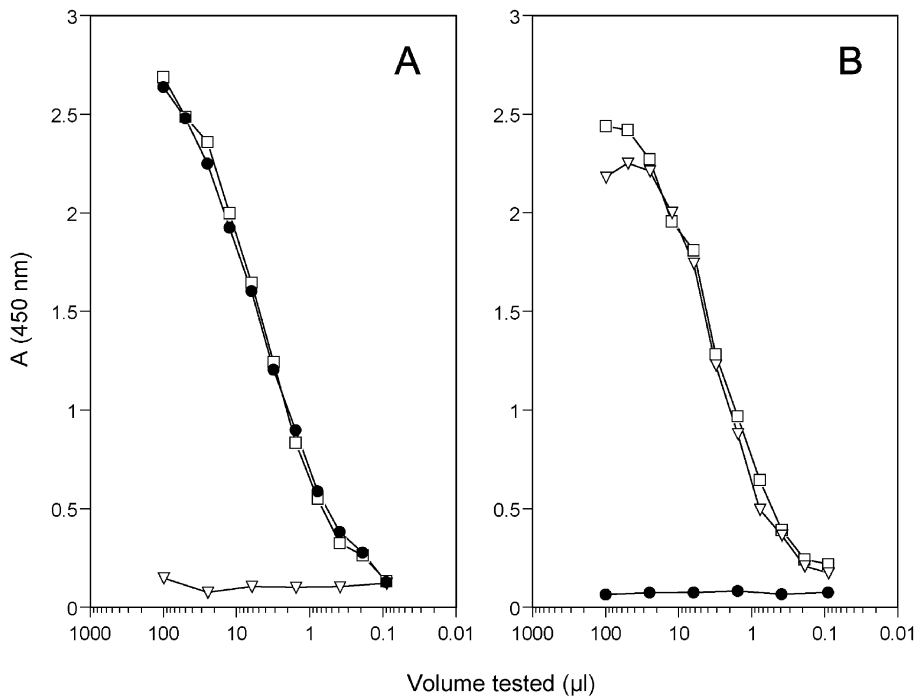

Fig. 2. Binding of mAbs E17 and E13 to the N- and C-lobe. Serial dilutions of natural hLF (100 ng/ml; \square) or medium of 293(S) cells secreting the recombinant hLF N-lobe (∇) or C-lobe (\bullet) were incubated with purified mAbs E13 (A) and E17 (B) coated onto microtiter plates. Bound hLF was detected by subsequent incubation with horseradish peroxidase-conjugated anti-hLF. The A_{450} values of converted substrate are plotted against the experimental volume tested.

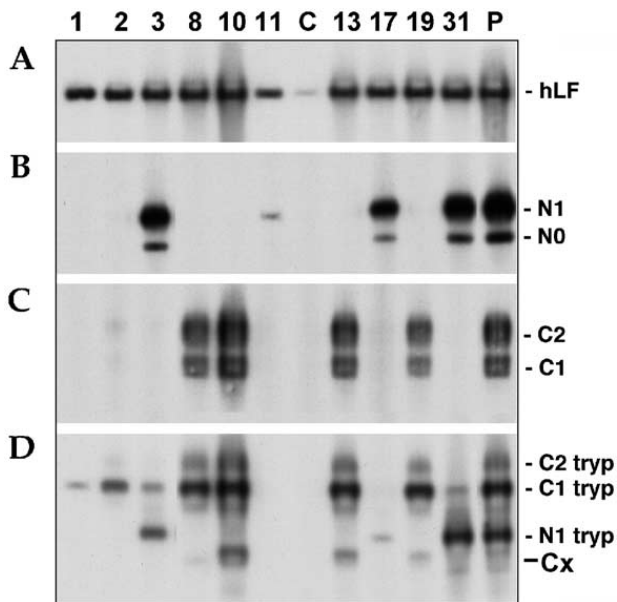

Fig. 3. Localization of the antibody epitopes on human lactoferrin. Non-reducing 12.5% (w/v) SDS-PAGE and immunoblot analysis of anti-hLF mAbs (1 μ g/ml) with natural hLF (A), purified recombinant N- or C-lobe (B, C) or trypsinized hLF (D). The antibody used for immunoblotting is indicated above each lane. The recombinant N-lobe band N0 represents unglycosylated N-lobe, whereas N1 represents N-lobe bearing one N-linked glycan. The C-lobe bands C1 and C2 represent C-lobe bearing one and two N-linked glycans, respectively. The tryptic cleavage products of hLF and their sizes are: N1^{tryp} (residues 4 to 283; Mr 39,000), C1^{tryp} (residues 284 to 692; Mr 51,000), C2^{tryp} (same residues as C1^{tryp} with an additional N-linked glycan attached to Asn⁶²⁴ (van Berkel et al., 1995); Mr 54,000) and C^x (cleavage site unknown; Mr 37,000). Bound mAb was detected by incubation with peroxidase labelled goat anti-mouse immunoglobulin.

N- or C-lobe but did bind to C1^{tryp}. This mAb bound to the fluid-phase recombinant C-lobe in the ELISA experiments (Table 1), which suggests that its epitope on the recombinant C-lobe is apparently denatured on SDS-PAGE; hence, we concluded that the conformational epitope for E2 is present on the native and trypsinized C-lobe. Fig. 3 shows that E8, E10, E13 and E19 bound to the C-lobe as well as to C1^{tryp} and C2^{tryp} (residues 284–692 with two N-linked glycan chains, Mr of 54,000). This indicates that they recognize epitopes in the C-lobe. The mAbs E10, E13 and E19 also bound to a tryptic cleavage product of Mr 37,000, designated C^x.

The mAbs E3, E11, E17 and E31 recognize N-lobe specific epitopes, present in both fluid-phase (Table 1) and blotted (Fig. 3B) recombinant N-lobe. Binding of

E11 to the supposedly denatured N-lobe on the immunoblot was very weak (Fig. 3B). Like E17, E11 did not bind to N1^{tryp} (residues 4–283, Mr of 39,000), suggesting that their epitopes were completely or partially destroyed upon tryptic cleavage of the molecule. Furthermore, two of the N-lobe specific mAbs, E3 and E31, also bound weakly to C1^{tryp} but not to the recombinant C-lobe (Fig. 3C), indicating that C-terminal residues may contribute to the conformational epitope which is mainly formed by N-lobe residues.

3.5. Binding of the mAbs to lactoferrin

We determined whether the mAbs bound to lactoferrin H (residues Gly¹ to Ile⁴⁷), a potent bactericidal peptide that is released from hLF by pepsin (Bellamy et al., 1992). It appeared that except for mAb E11, none of the other mAbs bound to lactoferrin H immobilized onto microtiter plates (representative results with E3 are shown in Fig. 4). Thus, E11 binds to a conformational epitope located between amino acids 1 and 47.

3.6. Development of a mAb-based quantitative assay of hLF

A useful application of this panel of mAbs would be in a quantitative sandwich-type immunoassay, e.g. based on the capture of hLF with a high affinity anti-C-lobe antibody and its detection with an anti-N-lobe antibody. An hLF-specific RIA was developed using E19 immobilized onto Sepharose and ¹²⁵I-E3 (Fig. 5A, open squares). This assay can detect as little as 4 ng of hLF. An ELISA procedure was also developed with a sensitivity of 0.3 ng, which is close to the sensitivity of an hLF-specific ELISA employing rabbit and bovine polyclonal anti-hLF antibodies (0.05 ng; van Berkel et al., 1996). Experiments in which the options of double antibody immunoassay with ¹²⁵I-E3 and other anti-hLF mAbs coupled to Sepharose were explored, indicated that the binding of E17 to natural hLF prevented the binding of E3, whereas natural hLF bound to E31 could still be detected with E3 (Fig. 5A). Hence, E3 appears to bind closely to the epitope of E17, but not to the epitope of E31. Similar control experiments with polyclonal ¹²⁵I-anti-hLF instead of ¹²⁵I-E3 are presented in Fig. 5B.

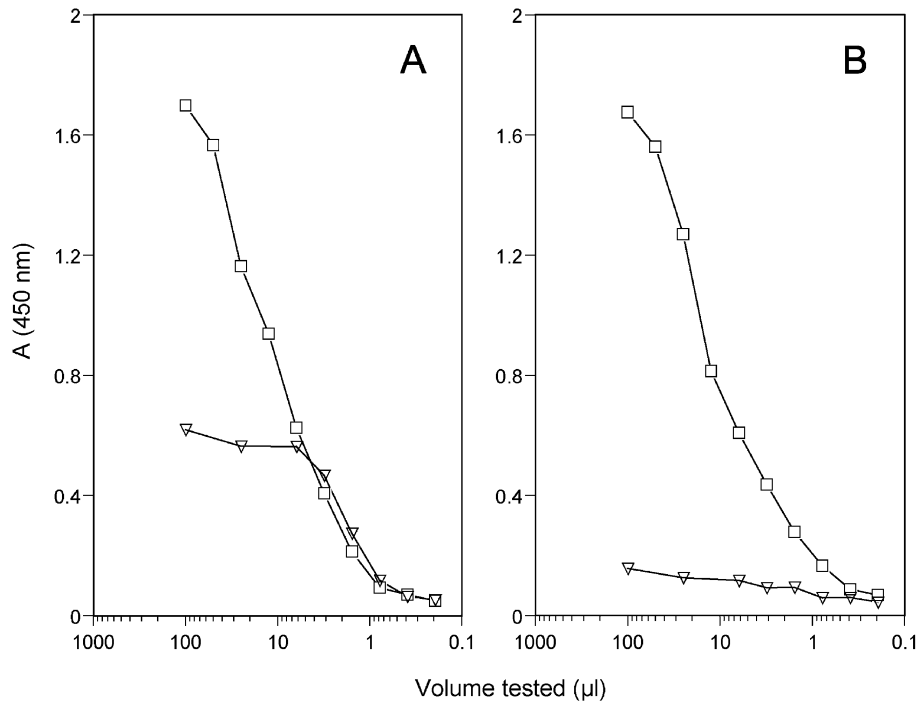

Fig. 4. Binding of mAbs E3 and E11 to recombinant lactoferricin H. Polysorp plates were coated with natural hLF (\square) or lactoferricin H (∇) in PBS. After washing, wells were incubated with a serial dilution of 10 $\mu\text{g/ml}$ E11 (A) and E3 (B) in PTG. After another wash, bound mAb was detected by incubation with peroxidase labelled goat anti-mouse immunoglobulin. The A_{450} values of converted substrate are plotted as a function of the volume tested.

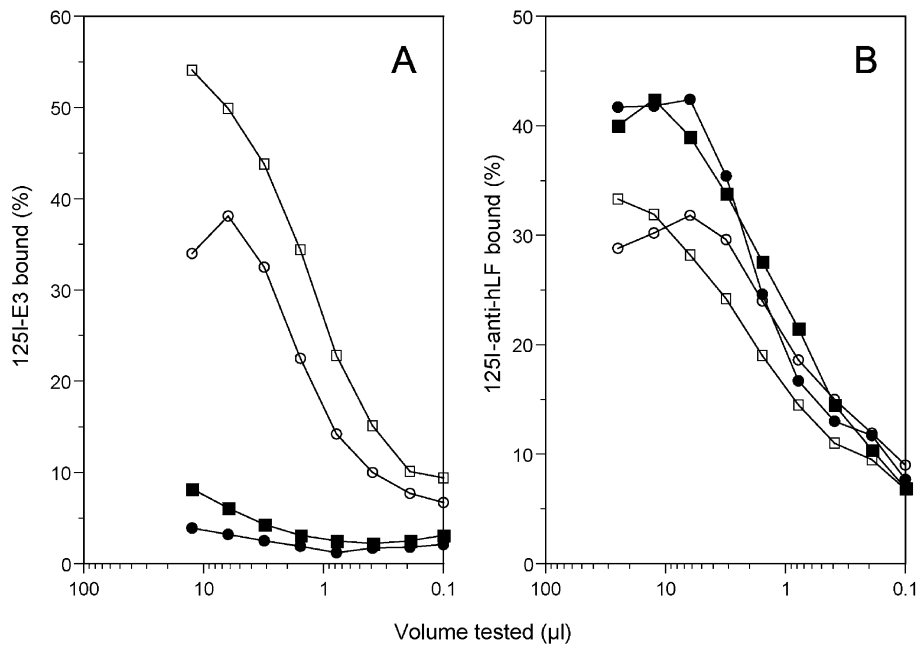

Fig. 5. Development of a mAb-based sandwich-type RIA of hLF. Monoclonal antibodies E3 (\blacksquare), E17 (\bullet), E31 (\circ) and E19 (\square) were coupled to Sepharose and incubated with a serial dilution of 10 $\mu\text{g/ml}$ natural hLF as previously described (Nuijens et al., 1997). After washing, bound hLF was detected with ^{125}I -E3 (radiolabelled by using Iodo-beads according to the manufacturer's instructions; panel A), or polyclonal rabbit ^{125}I -anti-hLF (panel B). Results are expressed as the percentage binding of the ^{125}I -labelled antibodies added. The volume of the hLF sample tested (μl) is indicated on the abscissa.

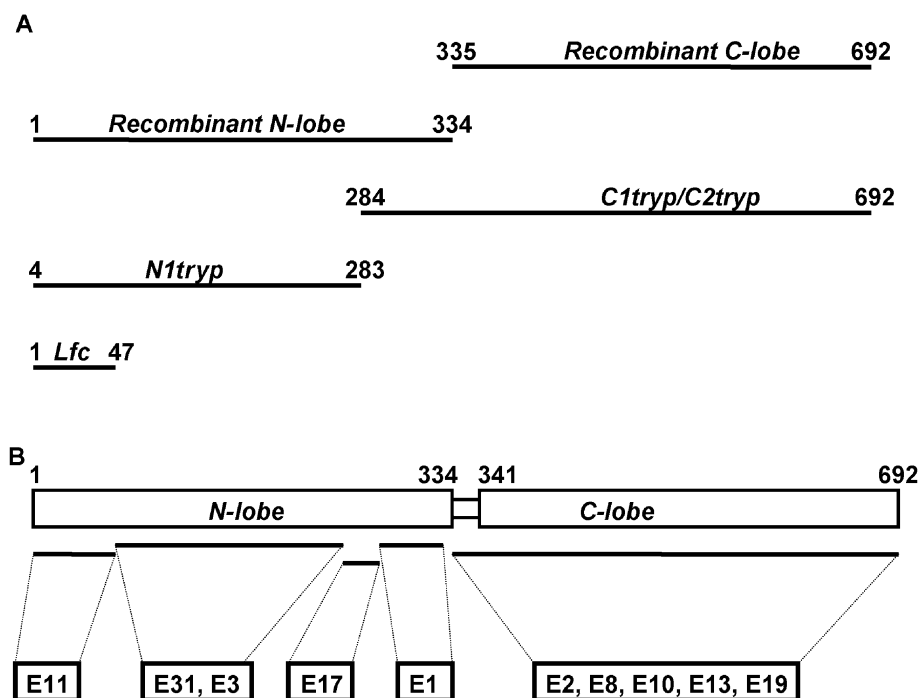

Fig. 6. Localization of the epitopes on hLF. Overview of the recombinant and tryptic hLF-fragments (A) and putative epitope localization (B) of anti-hLF mAbs. The numbers correspond to the amino acid residues of the hLF protein sequence. The region between residues 334 and 341 represents the connecting three-turn α -helix (not drawn to scale).

Fig. 6A gives an overview of the recombinant and tryptic hLF fragments used for the epitope mapping studies. Fig. 6B depicts the putative epitope locations for the anti-hLF mAbs, which are inferred from the results of Table 1 and Figs. 2–5.

4. Discussion

Monoclonal antibodies against hLF appear to be useful tools to identify regions of the molecule that are important for its biological activity (van Berkel et al., 1997). Here, we describe the production of 10 distinct mAbs against hLF recognising conformational epitopes located in both the N- and C-lobe (Fig. 6). Although several reports of anti-hLF antibodies have appeared (Chung et al., 1985; Broxmeyer et al., 1986; Skubitz et al., 1989; Caccavo et al., 1996, 1999), this paper is the first to describe the characterisation of a large panel of mAbs against hLF in more detail.

Human lactoferrin has been shown to display antimicrobial activity in vitro and in vivo (Nuijens et al., 1996). In addition, a variety of in vitro obser-

vations suggest that the protein can act in vivo to modulate inflammatory and coagulation responses (Nuijens et al., 1996). The sequestration of free iron plays a central role in at least some of these biological activities. For example, the bacteriostatic activity of hLF is mediated through limiting the availability of environmental iron, a growth requirement for many microbial species (Reiter et al., 1975) and the sequestration of free iron inhibits the iron-catalysed formation of hydroxyl radicals from superoxide and H_2O_2 released from neutrophils (Britigan et al., 1989). Comparative crystallographic studies of unsaturated and iron-saturated hLF revealed that, upon the binding of iron, domain II of the N- and C-lobe rotate 54° and 18° , respectively, with respect to domain I resulting in a more globular closed conformation of the entire molecule (Baker et al., 1996). We expected that the major conformational changes upon iron incorporation might translate to many neo-determinants in the saturated protein. Antibodies specific for unsaturated or saturated hLF would be very useful in assays to quantify the extent to which hLF is saturated with metal ions. Despite specific efforts including immu-

nisation and screening with iron-saturated hLF, we did not succeed in obtaining such an antibody: the exposure and/or conformation of the epitopes for the antibodies described herein appeared not to be affected by the conformational changes upon incorporation of iron as the affinities to each hLF species did not differ (Table 1).

The bactericidal and other biological activities of hLF do not depend on the sequestration of free iron, but relate to the binding of hLF to negatively charged molecules such as bacterial lipopolysaccharide, heparin, human lysozyme and DNA (van Berkel et al., 1997). The first basic cluster of hLF, Arg²-Arg³-Arg⁴-Arg⁵, is essential for these interactions (Mann et al., 1994; van Berkel et al., 1997). We have recently shown that E11 binds to an epitope located in the N-lobe and can completely block the interaction of hLF with anionic ligands (van Berkel et al., 1997; El Yazidi-Belkoura et al., 2001). Here we show that E11 binds to lactoferricin (residues 1–47; Fig. 4), but not to N1^{tryp} lacking Gly¹-Arg²-Arg³ (Fig. 3). The lack of binding to N1^{tryp} on blots seems to contrast with the previous observation that E11 can bind to fluid-phase rhLF^{-5N}, a mutant lacking the first 5 N-terminal residues, although with reduced affinity (van Berkel et al., 1997). However, this apparent discrepancy may reflect the fact that the first cationic cluster contributes to a conformational epitope that is further affected when N1^{tryp} is subjected to additional denaturation by SDS. The latter likely also accounts for the weak reaction of E11 with the recombinant N-lobe on immunoblots (Fig. 3) in comparison with the other anti-N-lobe mAbs having an identical affinity to fluid-phase natural hLF (Table 1). These considerations imply that the N-terminus of hLF not only projects out of the molecule, but indeed may interact with the second cationic cluster to form a cationic cradle (Mann et al., 1994).

Next to the major tryptic cleavage site at Arg³, the N-lobe of hLF contains another major tryptic cleavage site at Lys²⁸³ (Legrand et al., 1997). The N-lobe specific mAb E17 bound to natural hLF as well as the recombinant N-lobe (Table 1, Figs. 2 and 3), but only very weakly bound to N1^{tryp}, particularly when compared to E3 and E31. This indicates that tryptic cleavage at Lys²⁸³ affects the epitope for mAb E17, implying that residues at or near Lys²⁸³ contribute to the conformational epitope for E17.

The mAbs E3 and E31 bind to the N-lobe and N1^{tryp}, but not to lactoferricin H, indicating that residues between 48 and 283 contribute to their conformational epitopes. Both E3 and E31 weakly bind to C1^{tryp}, whereas they do not bind to the recombinant C-lobe indicating that residues between 284 and 335 may also contribute to their conformational epitope. E3 and E31 bind to different epitopes as was determined by cross-blocking experiments (Fig. 5). Pre-incubation of hLF with E17 inhibited the binding of E3, which suggests that the E3 and E17 epitopes are located near each other (Fig. 5).

E1 likely also binds to the N-lobe. This mAb binds weakly to C1^{tryp} but not to the recombinant C-lobe (Fig. 3) suggesting that its conformational epitope resides between residues 284 and 335, i.e. the N-lobe part of C1^{tryp}. At this stage, we do not know why E1 does not bind to the fluid-phase or blotted recombinant N-lobe, although it might be explained by the fact that the conformational epitope for E1 is altered in the recombinant half molecule.

The epitopes of five mAbs, E2, E8, E10, E13 and E19, reside in the C-lobe (Fig. 6). At least three of them, i.e. E2, E8 and E10 have unique features (Table 1, Figs. 1 and 3), hence they likely bind to different epitopes. For more detailed mapping, further research using C-lobe fragments or rhLF mutant molecules is needed. Such effort appears complicated by the C-lobe containing 10 disulphide bridges (Metz-Boutigue et al., 1984) and the fact that reduction abolishes the binding of the mAbs to hLF.

The transferrin family is an important class of iron-transporting proteins widely distributed in the body fluids of vertebrates and invertebrates. The members include lactoferrin, serum transferrin, ovotransferrin and melanotransferrin (Crichton, 1990). These proteins share a high degree of sequence homology and overall structure (Crichton, 1990). For instance, hLF shares 51% amino acid identity with human transferrin. The binding studies with the anti-hLF mAbs suggest that, despite the high degree of sequence homology, considerable differences exist in their surface structure. The issue of common antigenicity between lactoferrin from different mammals has been debated. Some researchers reported that there is no cross-reactivity between hLF and bLF (Wang et al., 1984; Davidson and Lönnnerdal, 1986) or hLF and pLF (Kokriakov et al., 1988), while others reported

that hLF, bLF and pLF share antigenic determinants (Masson and Heremans, 1971; Magnuson et al., 1990). Our results clearly demonstrate that at least one epitope is conserved among hLF, bLF and pLF (Fig. 1), namely the C-lobe conformational epitope for mAb E8. The C-lobe epitope for mAb E2 is conserved between hLF and bLF. It is to be noted that sequence alignment of the lactoferrins of different species revealed that the highest homology occurs in the C-lobe, whereas the most pronounced differences are found in domain I of the N-lobe (Pierce et al., 1991; Lydon et al., 1992).

In summary, we have obtained a panel of 10 distinct mAbs against hLF, which will be applied in structure–function relationship studies as well as in quantitative and qualitative immunoassays of hLF, i.e. to develop recombinant hLF from transgenic cattle for applications in human healthcare.

Acknowledgements

We thank Dr. B. Colargol (Erasmus University, Rotterdam, The Netherlands) for stimulating discussions.

References

- Anderson, B.F., Baker, H.M., Norris, G.E., Rice, D.W., Baker, E.N., 1989. Structure of human lactoferrin: crystallographic structure analysis and refinement at 2.8 Å resolution. *J. Mol. Biol.* 209, 711.
- Arnold, R.R., Cole, M.F., McGhee, J.R., 1977. A bactericidal effect for human lactoferrin. *Science* 197, 263.
- Baker, E.N., Anderson, B.F., Baker, H.M., Faber, R., Smith, C.A., Sutherland-Smith, A.J., 1996. Structural and Functional Flexibility of Lactoferrin. Humana Press, Totowa, NJ.
- Bellamy, W., Takase, M., Yamauchi, K., Wakabayashi, H., Kawase, K., Tomita, M., 1992. Identification of the bactericidal domain of lactoferrin. *Biochim. Biophys. Acta* 1121, 130.
- Britigan, B.E., Hassett, D.J., Rosen, G.M., Hamill, D.R., Cohen, M.S., 1989. Neutrophil degranulation inhibits potential hydroxyl-radical formation. Relative impact of myeloperoxidase and lactoferrin release on hydroxyl-radical production by iron-supplemented neutrophils assessed by spin-trapping techniques. *Biochem. J.* 264, 447.
- Broxmeyer, H.E., Bicknell, D.C., Gillis, S., Harris, E.L., Pelus, L.M., Sledge, G.J., 1986. Lactoferrin: affinity purification from human milk and polymorphonuclear neutrophils using monoclonal antibody (II 2C) to human lactoferrin, development of an immunoradiometric assay using II 2C, and myelopoietic regulation and receptor-binding characteristics. *Blood Cells* 11, 429.
- Caccavo, D., Afeltra, A., Guido, F., Di Monaco, C., Ferri, G.M., Amoroso, A., Vaccaro, F., Bonomo, L., 1996. Two spatially distant epitopes of human lactoferrin. *Hybridoma* 15, 263.
- Caccavo, D., Afeltra, A., Pece, S., Giuliani, G., Freudenberg, M., Galanos, C., Jirillo, E., 1999. Lactoferrin–lipid A–lipopolysaccharide interaction: inhibition by anti-human lactoferrin monoclonal antibody AGM 10.14. *Infect. Immun.* 67, 4668.
- Chung, S., Hayward, C., Brock, D.J., Van, H.V., 1985. A monoclonal antibody-based immunoassay for human lactoferrin. *J. Immunol. Methods* 84, 135.
- Crichton, R.R., 1990. Proteins of iron storage and transport. *Adv. Protein Chem.* 40, 281.
- Crouch, S.P., Slater, K.J., Fletcher, J., 1992. Regulation of cytokine release from mononuclear cells by the iron-binding protein lactoferrin. *Blood* 80, 235.
- Davidson, L.A., Lönnerdal, B., 1986. Isolation and characterization of rhesus monkey milk lactoferrin. *Pediatr. Res.* 20, 197.
- Ellison III, R.T., Giehl, T.J., 1991. Killing of gram-negative bacteria by lactoferrin and lysozyme. *J. Clin. Invest.* 88, 1080.
- El Yazidi-Belkoura, I., Legrand, D., Nuijens, J., Slomianny, M.C., van Berkel, P., Spik, G., 2001. The binding of lactoferrin to glycosaminoglycans on enterocyte-like HT29-18-C1 cells is mediated through basic residues located in the N-terminus. *Biochim. Biophys. Acta* 1568, 197.
- Fazekas de St Groth, S., Scheidegger, D., 1980. Production of monoclonal antibodies: strategy and tactics. *J. Immunol. Methods* 35, 1.
- Hutchens, T.W., Henry, J.F., Yip, T.T., 1991. Structurally intact (78-kDa) forms of maternal lactoferrin purified from urine of pre-term infants fed human milk: identification of a trypsin-like proteolytic cleavage event in vivo that does not result in fragment dissociation. *Proc. Natl. Acad. Sci. U. S. A.* 88, 2994.
- Kijlstra, A., Jeurissen, S.H.M., 1982. Modulation of the classical C3 convertase of complement by tear lactoferrin. *Immunology* 47, 263.
- Kokriakov, V.N., Aleshina, G.M., Slepnev, S.V., Iakovleva, M.F., Pigarevskii, V.E., 1988. Degree of structural homology of lactoferrins from milk and neutrophilic granulocytes. *Biokhimiia* 53, 1837.
- Legrand, D., Mazurier, J., Aubert, J.P., Loucheux, M.H., Montreuil, J., Spik, G., 1986. Evidence for interactions between the 30 kDa N- and 50 kDa C-terminal tryptic fragments of human lactoferrin. *Biochem. J.* 236, 839.
- Legrand, D., van Berkel, P.H.C., Salmon, V., van Veen, H.A., Slomianny, M.C., Nuijens, J.H., Spik, G., 1997. The N-terminal Arg2, Arg3 and Arg4 of human lactoferrin interact with sulphated molecules but not with the receptor present on Jurkat human lymphoblastic T-cells. *Biochem. J.* 327, 841.
- Lydon, J.P., O'Malley, B.R., Saucedo, O., Lee, T., Headon, D.R., Conneely, O.M., 1992. Nucleotide and primary amino acid sequence of porcine lactoferrin. *Biochim. Biophys. Acta* 1132, 97.
- Magnuson, J.S., Henry, J.F., Yip, T.T., Hutchens, T.W., 1990. Structural homology of human, bovine, and porcine milk lactoferrins: evidence for shared antigenic determinants. *Pediatr. Res.* 28, 176.
- Mann, D.M., Romm, E., Migliorini, M., 1994. Delineation of the

- glycosaminoglycan-binding site in the human inflammatory response protein lactoferrin. *J. Biol. Chem.* 269, 23661.
- Masson, P.L., Heremans, J.F., 1971. Lactoferrin in milk from different species. *Comp. Biochem. Physiol., B* 39, 119.
- Metz-Boutigue, M., Jolles, J., Mazurier, J., Schoentgen, F., Legrand, D., Spik, G., Montreuil, J., Jolles, P., 1984. Human lactotransferrin: amino acid sequence and structural comparisons with other transferrins. *Eur. J. Biochem.* 145, 659.
- Müller, R., 1983. Determination of affinity and specificity of anti-hapten antibodies by competitive radioimmunoassay. *Methods Enzymol.* 92, 589.
- Nibbering, P.H., Ravensbergen, E., Welling, M.M., van Berkel, L.A., van Berkel, P.H.C., Pauwels, E.K.J., Nuijens, J.H., 2001. Human lactoferrin and peptides derived from its N-terminus are highly effective against infections with antibiotic resistant bacteria. *Infect. Immun.* 69, 1469.
- Nuijens, J.H., van Veen, H.A., 1998. Isolation of lactoferrin from milk. US Patent 5849885.
- Nuijens, J.H., van Berkel, P.H.C., Schanbacher, F.L., 1996. Structure and biological actions of lactoferrin. *J. Mammary Gland Biol. Neoplasia* 1, 285.
- Nuijens, J.H., van Berkel, P.H., Geerts, M.E., Hartevelt, P.P., de Boer, H.A., van Veen, H.A., Pieper, F.R., 1997. Characterization of recombinant human lactoferrin secreted in milk of transgenic mice. *J. Biol. Chem.* 272, 8802.
- Pierce, A., Colavizza, D., Benaissa, M., Maes, P., Tartar, A., Montreuil, J., Spik, G., 1991. Molecular cloning and sequence analysis of bovine lactotransferrin. *Eur. J. Biochem.* 196, 177.
- Reiter, B., Brock, J.H., Steel, E.D., 1975. Inhibition of *Escherichia coli* by bovine colostrum and post-colostral milk: II. The bacteriostatic effect of lactoferrin on a serum-susceptible and serum-resistant strain of *E. coli*. *Immunology* 28, 83.
- Rey, M.W., Woloshuk, S.L., de Boer, H.A., Pieper, F.R., 1990. Complete nucleotide sequence of human mammary gland lactoferrin. *Nucleic Acids Res.* 18, 5288.
- Skubitz, K.M., Christiansen, N.P., Mendiola, J.R., 1989. Preparation and characterization of monoclonal antibodies to human neutrophil cathepsin G, lactoferrin, eosinophil peroxidase, and eosinophil major basic protein. *J. Leukoc. Biol.* 46, 109.
- van Berkel, P.H.C., Geerts, M.E.J., van Veen, H.A., Kooiman, P.M., Pieper, F., de Boer, H.A., Nuijens, J.H., 1995. Glycosylated and unglycosylated human lactoferrins can both bind iron and have identical affinities towards human lysozyme and bacterial lipopolysaccharide, but differ in their susceptibility towards tryptic proteolysis. *Biochem. J.* 312, 107.
- van Berkel, P.H., van Veen, H.A., Geerts, M.E., de Boer, H.A., Nuijens, J.H., 1996. Heterogeneity in utilization of *N*-glycosylation sites Asn624 and Asn138 in human lactoferrin: a study with glycosylation-site mutants. *Biochem. J.* 319, 117.
- van Berkel, P.H.C., Geerts, M.E.J., van Veen, H.A., Mericskay, M., de Boer, H.A., Nuijens, J.H., 1997. The N-terminal stretch Arg2 Arg3, Arg4 and Arg5 of human lactoferrin is essential for binding to heparin, bacterial lipopolysaccharide, human lysozyme and DNA. *Biochem. J.* 328, 145.
- Wang, C.S., Chan, W.Y., Kloer, H.U., 1984. Comparative studies on the chemical and immunochemical properties of human milk, human pancreatic juice and bovine milk lactoferrin. *Comp. Biochem. Physiol., B* 78, 575.

Chapter 4

Characterization of the recombinant N- and C-lobe of human lactoferrin

Harrie A. van Veen, Marlieke E.J. Geerts, Jan H. Nuijens and Patrick H.C. van Berkel

Abstract

Human lactoferrin (hLF), an iron-binding N-linked glycoprotein of Mr 77,000, consists of two highly homologous lobes, the N- and C-lobe. Functional activities of hLF reside in binding of metals like iron and ligands like bacterial lipopolysaccharide (LPS) or heparin. These properties were localized by using the recombinant N- and C-lobe expressed in human 293(S) cells. SDS-PAGE studies of untreated and enzymically deglycosylated recombinant lobes confirmed that the major iron-binding associated conformational change occurs in the N-lobe and that N-linked glycosylation is not essential in maintaining the stability of the iron-saturated N-lobe. Ligand binding assays revealed that lipid A and heparin as well as chelated iron appeared to bind only to the N-lobe, whereas chelated copper bound to both lobes.

Introduction

Human lactoferrin (hLF¹) is a metal-binding glycoprotein of Mr 77,000 that belongs to the transferrin family [1]. Human LF is found in secretions such as milk, tears, saliva as well as in the secondary granules of neutrophils [2]. Based on extensive in-vitro and in-vivo studies, showing LF to have antibacterial, antifungal, antiviral and anti-inflammatory activities, the molecule is postulated to be involved in the innate host defense against infection and excessive inflammation [2]. Many of the biological actions of LF are mediated by the sequestration of iron or by a positively charged domain located in the N-terminus which is involved in binding to negatively charged ligands such as the lipid A moiety of lipopolysaccharide (LPS) [3], DNA [4] and heparin [5].

The amino acid sequence of human lactoferrin (hLF) has been determined by protein and DNA sequencing [6, 7]. Human LF consists of a single polypeptide chain of 692 amino acids which is folded into two globular lobes (designated the N- and C-lobe) connected by an α -helix [1]. The N- and C-lobe share an internal amino acid homology of about 40% [6] suggesting that hLF evolved by gene duplication from an ancestral gene half its size. Each lobe consist of two domains (I and II), connected by a hinge region, creating a deep iron-binding cleft that can bind a single ferric ion with high affinity while simultaneously incorporating a bicarbonate ion [1]. Upon binding of iron, domain I of the N- and C-lobe rotates relative to domain II by $\sim 54^\circ$ and $\sim 20^\circ$, respectively, resulting in a more globular closed and stable conformation of hLF [8]. Besides the high affinity metal binding in the iron-binding cleft, LF can also bind metals at much lower affinity [9] which occurs at least in part via surface-exposed histidyl residues [10]. Human LF contains three possible N-glycosylation sites, Asn¹³⁸ in the N-lobe and Asn⁴⁷⁹ as well as Asn⁶²⁴ in the C-lobe which are utilized in $\sim 94\%$, 100% and $\sim 9\%$ of the molecules, respectively [11].

¹The abbreviations used are: LF, lactoferrin; hLF, human LF; natural hLF, hLF purified from human milk; iron-saturated hLF and Fe-hLF, natural hLF that has completely been saturated with iron in vitro; rN-lobe, recombinant N-lobe; rC-lobe, recombinant C-lobe.

The N-lobe of hLF has been cloned and expressed in BHK cells [12] and site-directed mutagenesis of this lobe has been employed [8] to obtain new insights into the structure and iron-binding properties of hLF. In contrast to the N-lobe, the expression of the C-lobe of hLF failed in BHK cells [13]. Recently, we reported the expression of the recombinant N- and C-lobe (rN- and rC-lobe) in human kidney 293(S) cells [14]. Herein, we describe the characterization of the expressed rN- and rC-lobe and the use of these lobes in studies of metal-binding, ligand interaction and N-linked glycosylation of hLF.

Materials and methods

Purification and saturation with iron of natural human lactoferrin

Natural hLF was purified from fresh human milk by cation-exchange chromatography on S Sepharose [15]. Natural hLF was saturated with iron for 4%; complete saturation of natural hLF with iron was achieved as described [15].

Expression and purification of the recombinant N- and C-lobe of hLF

Human kidney 293(S) cells [ATCC CRL 1573] were transfected with expression vectors based on regulatory elements from the bovine α S₁-casein gene and cDNA sequences encoding either for the hLF N-lobe (pCMV/rN, residues Gly¹ to Lys³³⁴) or the C-lobe, including the connecting α -helix (pCMV/rC, residues Ser³³⁵ to Lys⁶⁹²) [14]. Supernatants of (subcloned) 293(S) cells were tested for expression of the rN- or rC-lobe with a hLF-specific ELISA using natural hLF as standard [11] and the recombinant lobes were purified as described [14].

Binding of natural hLF, iron-saturated hLF and the recombinant lobes to Fe- and Cu-Chelating Sepharose

Immobilized metal-Chelating Sepharoses were prepared by incubating Chelating Sepharose (GE Healthcare, Uppsala, Sweden) with an excess of iron(II)sulphate or copper(II)chloride. The Sepharoses were then washed, suspended (8 μ l Sepharose/0.5 ml) and incubated with 100 ng (100 μ l, 1 μ g/ml) of purified natural hLF, iron-saturated hLF, rN-lobe or the rC-lobe in 10 mM sodium phosphate pH 7.0, 0.1% w/v Tween-20, 0.02% w/v sodium azide and 0.14, 0.56 or 1.8 M sodium chloride. After incubation for 16 h at 20°C, the suspensions were centrifuged and non-bound hLF, rN- or rC-lobe in the supernatants was determined with the ELISA specific for hLF. The specificity of the interaction of the lactoferrin variants with chelated metal was demonstrated by control experiments in which non-charged Chelating Sepharose was tested (result not shown).

Results

Expression of the recombinant N- and C-lobe of human lactoferrin in 293(S) cells

Subcloning of pCMV/rN or pCMV/rC transfected 293(S) cells resulted in stable lines expressing the recombinant N- or C-lobe, designated as the rN- and rC-lobe, respectively, up to 0.5 μ g/ml. N-terminal protein sequencing of purified rN- and rC-lobe showed sequences predicted by the DNA sequence (Table 1), which indicated that the bovine α S₁-casein signal sequence [14] was correctly and completely removed in 293(S) cells to yield the mature rN- and rC-lobe. Analysis of purified rN-lobe by analytical cation-exchange chromatography on Mono S revealed one major protein peak at 0.78 M NaCl (Figure 1), which is about 0.1 M higher than the elution of natural hLF [15]. The purified rC-lobe did not bind to Mono S (not shown). The binding of natural hLF and rN-lobe, but not of the rC-lobe to the negatively charged molecules heparin and lipid A indicated that this interaction is mediated by the N-lobe of hLF (Figure 2). These results confirm that the cationic nature of hLF is determined by its N-lobe.

Table 1 N-terminal sequence analysis of the recombinant N- and C-lobe

rN-lobe	N-terminal sequence ^a	GRRRRSVQWXAVSQPEATKXFQ
	cDNA sequence ^b	GRRRRSVQWCAVSQPEATKCFQ
↓		
rC-lobe	N-terminal sequence	<u>SEEEVAARRAR</u> VVWXAVGEQELRK ^c
	cDNA sequence	SEEEVAARRARVWCAVGEQELRK

^a N-terminal sequences were determined with the automatic Edman degradation procedure (Applied Biosystems gasphase sequencer, model 473A). Sequencing results are provided with the standard one-letter code for amino acids.

^b Predicted sequences based on the cDNA sequence of hLF [11].

^c The α -helix, connecting the N- and C-lobe, is indicated underlined; the arrow indicates the first residue of the C-terminal half [1].

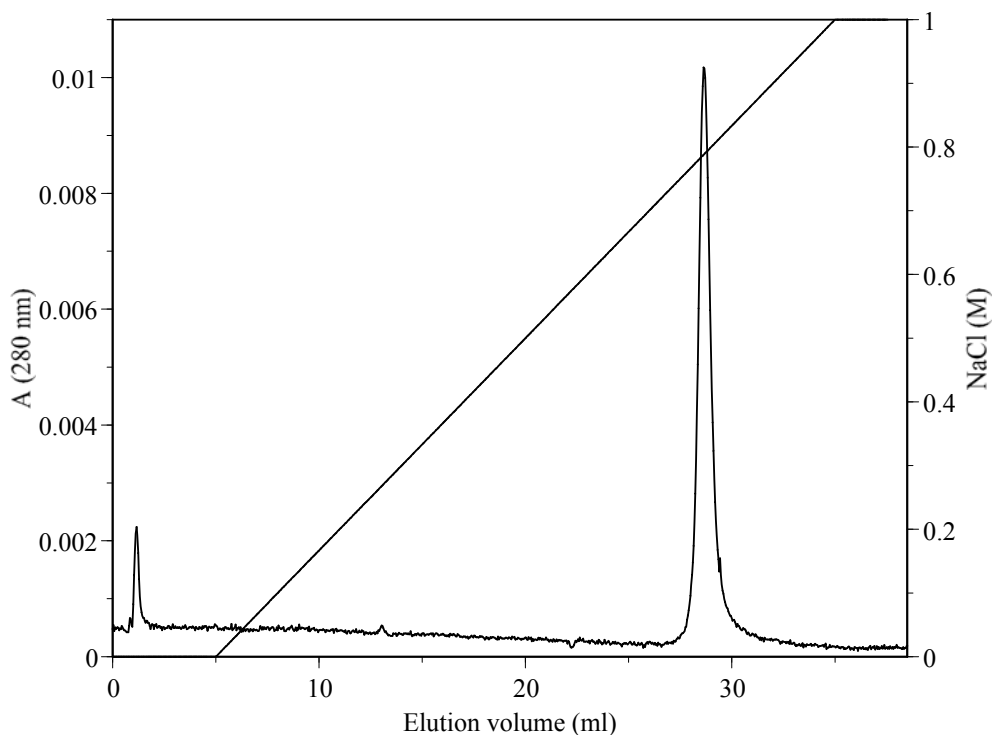

Figure 1 Mono S profile of the recombinant N-lobe

Ten μ g of S Sepharose purified rN-lobe was applied to a Mono S HR 5/5 column (GE Healthcare, Uppsala, Sweden) in 20 mM sodium phosphate, pH 7.5 (buffer A). Bound protein was eluted with a linear salt gradient from 0 to 1.0 M NaCl in 30 ml buffer A at a flow rate of 1.0 ml/min. Eluted protein was detected by absorbance measurement at 280 nm.

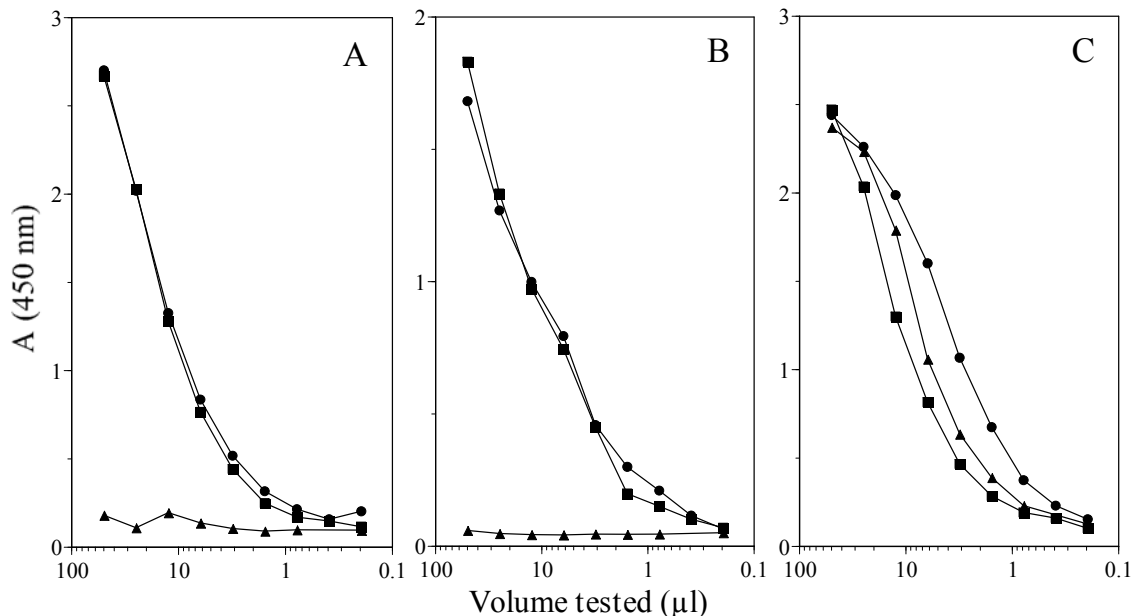

Figure 2 Binding of rN- and rC-lobe to solid-phase heparin and lipid A

Serial dilutions of natural hLF (■, 0.1 µg/ml), purified rN-lobe (●, 0.3 µg/ml) and rC-lobe (▲, 0.2 µg/ml) were incubated with solid-phase heparin (panel A), lipid A (panel B) and affinity purified rabbit anti-hLF (panel C) as described [20]. After incubation plates were washed and bound antigen was detected by incubation with peroxidase-conjugated bovine anti-hLF. The A_{450} values measured as described [20] are plotted against the experimental volume (µl) tested.

SDS-PAGE analysis of the recombinant N- and C-lobe of human lactoferrin

On non-reduced SDS-PAGE, boiled samples of purified rN-lobe migrated as a doublet of protein bands of Mr 44,000 and 40,000 (Figure 3A, lane 2). The rC-lobe migrated as two doublets of protein bands (Figure 3A, lane 3). The most prominent band within each doublet was of Mr 43,000 and 38,000. Immunoblotting analysis revealed that all protein bands observed on non-reduced SDS-PAGE were recognized by polyclonal anti-hLF antibodies as well as conformational specific monoclonal antibodies directed either against the N- or C-lobe of hLF [14]. On reduced SDS-PAGE, the rN-lobe migrated as a doublet of protein bands of Mr 45,000 and 42,000, at a ratio of 97:3 (Figure 3B, lane 2), whereas the rC-lobe migrated as a doublet of protein bands of Mr 47,000 and 43,000 at a ratio of 70:30 (Figure 3B, lane 3).

Previously, we showed that N-glycosylation heterogeneity at Asn¹³⁸ and Asn⁶²⁴ account for the minute, major and minor protein bands of hLF on SDS-PAGE [11]. SDS-PAGE analysis of untreated- and enzymically deglycosylated recombinant lobes revealed that the deglycosylated rN-lobe migrated as a protein band of Mr 40,000 with the same mobility as the band representing 3% of the untreated rN-lobe (Figure 4, lanes 3 and 4). This suggest that the protein of Mr 40,000 in untreated rN-lobe preparations, designated N₀, represented unglycosylated N-lobe and that the rN-lobe protein band of Mr 44,000 represented rN-lobe bearing one glycan attached to Asn¹³⁸ (designated N₁, Figure 4, lane 3). The deglycosylated rC-lobe showed a protein band of Mr 35,000 (designated C₀, Figure 4, lane 5) on non-reduced SDS-PAGE. Considering the two possible N-linked glycosylation sites in the C-lobe (Asn⁴⁷⁹ and Asn⁶²⁴), we hypothesized that the protein bands of Mr 38,000 and 43,000, designated C₁ and C₂, bear one and two glycans, respectively. Figure 5 depicts a model for the distribution of N-glycans in the recombinant N- and C-lobe, inferred from the results presented in Figure 4.

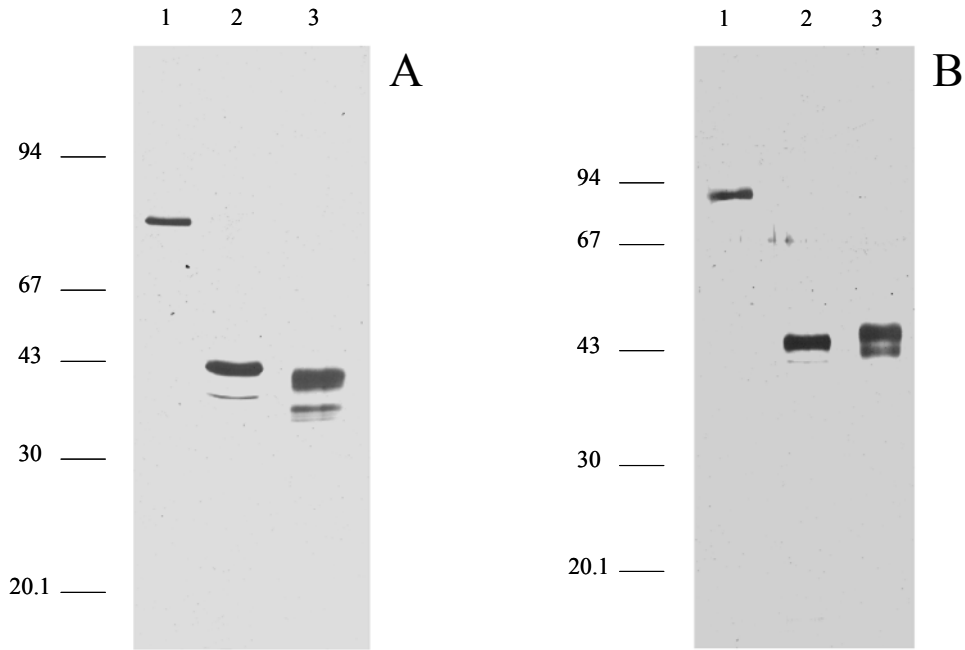

Figure 3 Non-reduced and reduced SDS-PAGE of purified rN- and rC-lobe

Samples were diluted in non-reducing (A) or reducing (B) sample buffer, boiled and applied to 12.5% (w/v) SDS-PAGE as described [15]. Lane 1: natural hLF, lane 2: rN-lobe and lane 3: rC-lobe. Proteins, about 350 ng per lane, were visualized by silver staining. Left-hand numbers ($10^3 \times \text{Mr}$) indicate the migration of the protein standards.

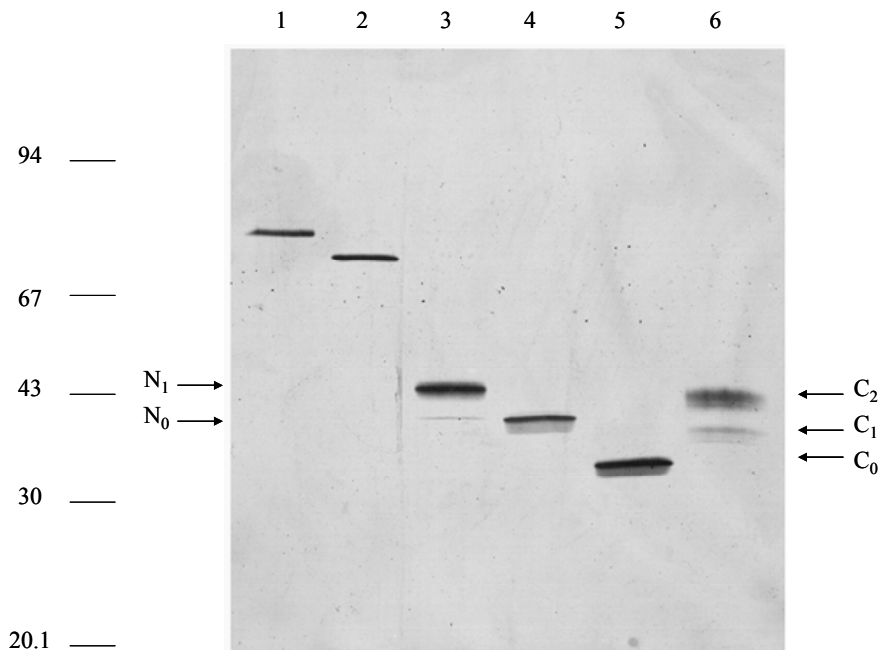

Figure 4 SDS-PAGE of enzymically deglycosylated rN- and rC-lobe

Human lactoferrin and recombinant lobes were deglycosylated with N-glycosidase F [11] and analyzed on non-reduced, boiled 12.5% (w/v) SDS-PAGE. Untreated (lane 1) and deglycosylated (lane 2) natural hLF; untreated (lane 3) and deglycosylated (lane 4) rN-lobe; deglycosylated (lane 5) and untreated (lane 6) rC-lobe. Proteins, about 500 ng per lane, were visualized by silver staining. Left-hand numbers ($10^3 \times \text{Mr}$) indicate the migration of the protein standards.

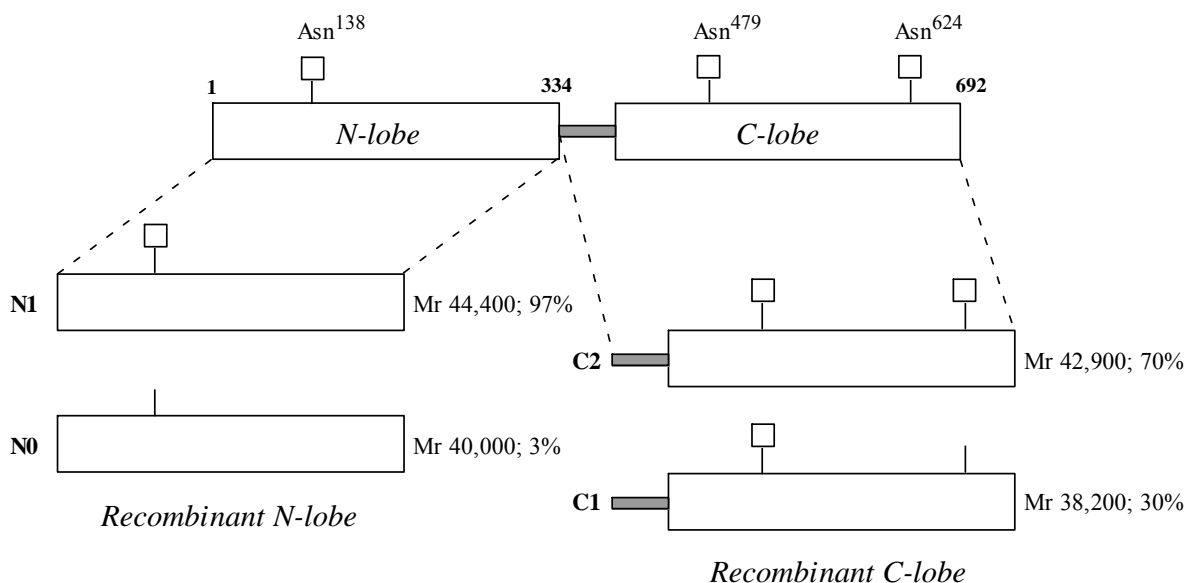

Figure 5 Proposed model for the distribution of N-glycans in the rN- and rC-lobe of human lactoferrin. Short vertical lines mark the potential N-linked glycosylation sites (Asn¹³⁸, Asn⁴⁷⁹ and Asn⁶²⁴) in natural hLF [11] and the recombinant lobes and a box on top of that indicates that the site is actually used. The α -helix connecting the N- and C-lobe is in grey. The Mr values and percentages indicated are based on densitometric analysis (IplabGel, Signal Analytics, Vienna, VA, USA) of at least four SDS-PAGE gels.

The N-lobe of hLF determines the conformational change on SDS-PAGE.

The binding of metal ions to hLF is coincided by a change in the conformation of this molecule [8] and SDS-PAGE under non-reducing conditions of freshly diluted, non-boiled samples can be used to assess the degree of saturation with iron of hLF [16]. Under these conditions the migration of iron-saturated hLF is faster than that of unsaturated hLF. Boiling of the protein in the presence of SDS causes denaturation of the iron-saturated molecule with release of iron [16]. Iron-saturated hLF as well as the purified recombinant N- and C-lobe were analyzed on non-reduced SDS-PAGE after boiling of the samples or not. The faster migration of iron-saturated hLF (Fe-hLF, Figure 6, lane 1) when compared to unsaturated hLF (Apo-hLF, Figure 6, lane 2) reflects the conformational change that occurred in hLF upon the incorporation of iron. The difference in Mr between these two conformations of natural hLF is approximately 8,000. Non-boiled and boiled rN-lobe showed major bands of Mr 36,000 (Fe-N₁, Figure 6, lane 3) and 44,000 (Apo-N₁, Figure 6, lane 4), respectively, indicating that the rN-lobe was fully saturated with iron, which was released upon boiling. The unglycosylated rN-lobe, N₀, was also found in the iron-saturated conformation (Fe-N₀, Figure 6, lane 3). No differences in the mobility of bands representing the purified rC-lobe were observed after boiling of the samples or not, (Figure 6, compare lanes 5 and 6). The addition of freshly prepared FeNTA-solution to the rC-lobe to increase the degree of iron-saturation prior to SDS-PAGE did also not reveal a differential mobility between boiled and non-boiled samples (not shown). These results suggest that the major conformational change of hLF observed on SDS-PAGE upon incorporation of iron occurs in the N-lobe. This conformational change is resistant to SDS and accounts for the possibility to assess the degree of iron-saturation of natural hLF [17] and rN-lobe preparations by non-reduced, non-boiled SDS-PAGE.

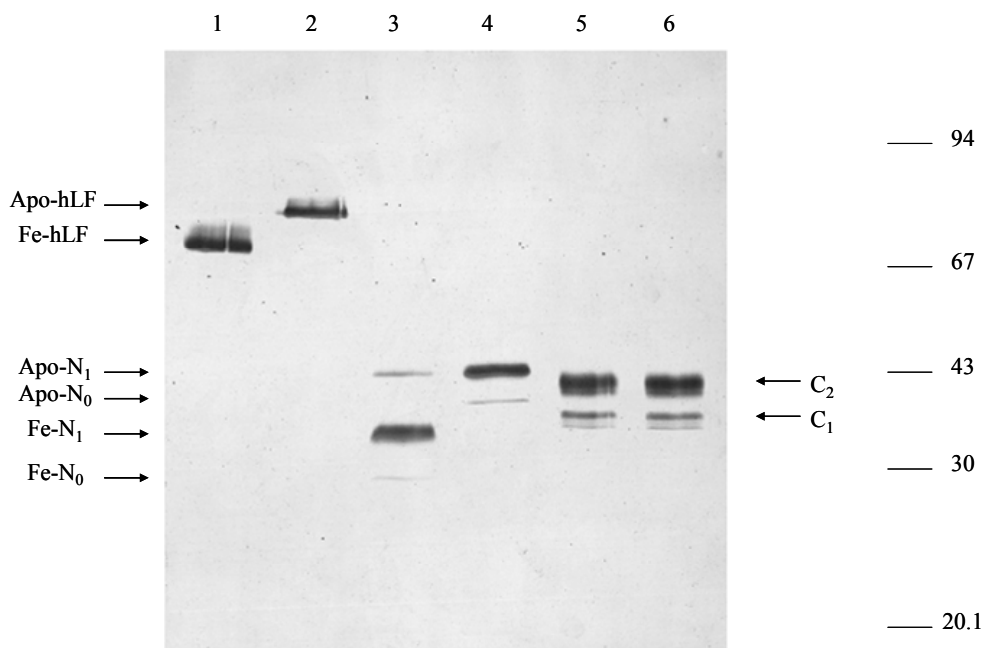

Figure 6 Iron-saturation of the rN- and rC-lobe

Purified natural hLF and recombinant lobes were freshly diluted in non-reducing SDS sample buffer and applied to 12.5% (w/v) non-reducing SDS-PAGE either directly or after boiling for 5 min. Non-boiled (lane 1) and boiled sample (lane 2) of iron-saturated natural hLF; non-boiled (lane 3) and boiled (lane 4) sample of the rN-lobe; non-boiled (lane 5) and boiled (lane 6) sample of the rC-lobe. Proteins, 300 ng per lane, were visualized by silver staining. Right-hand numbers ($10^{-3} \times \text{Mr}$) indicate the migration of the protein standards.

The N-lobe of human lactoferrin determines binding to Fe-Chelating Sepharose.

Lactoferrin can bind to metals through surface-exposed residues [9, 10, 18]. To determine whether surface exposed residues in the N- or C-lobe play a role in the interaction with chelated metals, the binding of natural hLF, iron-saturated hLF and the recombinant lobes to Fe- and Cu-Chelating Sepharose were studied. At low salt concentrations i.e. 0.14 M NaCl, all added rN-lobe and approximately 75% of natural and iron-saturated hLF bound to Fe-Chelating Sepharose, whereas only about 5% of the rC-lobe bound (Figure 7, open bars). At 0.56 M NaCl, all hLF variants had lost their ability to bind to Fe-Chelating Sepharose, whereas with Cu-Chelating Sepharose (and even at 1.8 M NaCl; not shown) each hLF variant had retained the capacity to bind (Figure 7, black and grey bars, respectively). These results indicate that the interaction of hLF with chelated iron is different from the interaction with chelated copper. The interaction with chelated iron is determined by the N-lobe and ionic in nature, whereas chelated copper can coordinate to likely surface-exposed histidyl residues in both lobes.

Discussion

This paper describes the characterization of the recombinant N- and C-lobe of hLF expressed in human kidney 293(S) cells. Recombinant production of the N- and C-lobe enables studies of the relation between the structure of hLF and its function. Characterization of the structure and iron-binding properties of the recombinant N-lobe and mutants, produced in BHK cells, has been described [8, 19], but expression of the C-lobe in these cells had failed presumably due to rapid degradation of translated C-lobe within the cell [13]. We produced the N- and C-lobe of hLF in human 293(S) cells and obtained recombinant lobes of high purity and devoid of proteolysis (Figure 3, Table 1). Successful expression of

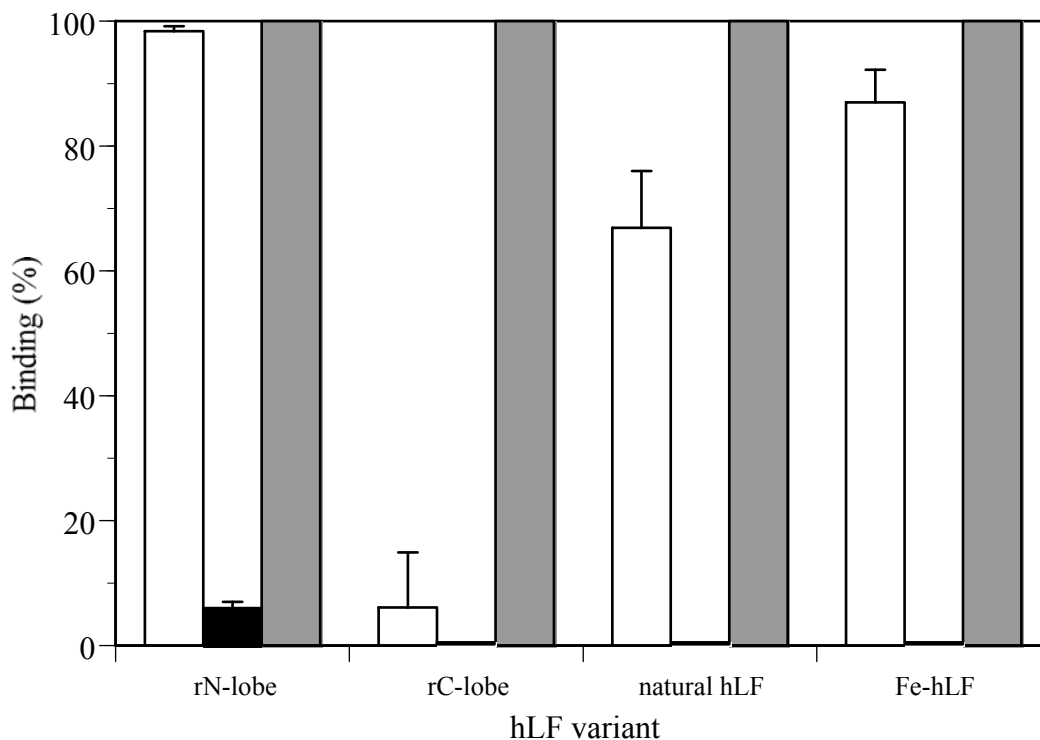

Figure 7 Interaction of hLF variants with immobilized metals

Binding of natural hLF, iron-saturated hLF, recombinant N- and C-lobe to Fe- and Cu-Chelating Sepharose was investigated as described in the Materials and Methods section. Open and black bars represent the results with Fe-Chelating Sepharose when incubated in 0.14 and 0.56 M NaCl, respectively. Grey bars show the result with Cu-Chelating Sepharose at 0.56 M NaCl. The percentage of protein bound to the metal-Chelating Sepharose is indicated on the ordinate. Results are given as mean \pm SD of at least 2 experiments.

the C-lobe in human 293(S) cells may relate to culture conditions, this particular cell type or to the fact that we included the entire connecting α -helix to the C-lobe whereas Sheth et al. (1994) did not.

Recently, it was demonstrated that basic clusters in the N-terminus of hLF determine the electrostatic interaction of this protein with LPS, heparin, human lysozyme, DNA as well as certain receptors [5, 20-22]. Cation-exchange chromatography (Figure 1) and binding experiments with the purified recombinant lobes to the negatively charged ligands heparin and lipid A (Figure 2) confirmed that the cationic properties of hLF localize to its N-lobe.

SDS-PAGE analysis of both untreated and deglycosylated purified recombinant lobes (Figure 4) provided proof that the N_1 and N_0 bands of the rN-lobe as well as C_2 and C_1 bands of the rC-lobe result from N-glycosylation heterogeneity. Based on our model for the distribution of the N-glycans in natural hLF [11] and the observations in Figure 4, a model is proposed for the distribution of N-glycans in the recombinant lobes (Figure 5). Similar to natural hLF [11], a minor portion of the rN-lobe (about 3%) is not glycosylated at Asn¹³⁸ (N_0 , Figure 4), whereas 97% of the molecules contain a glycan at Asn¹³⁸ (N_1 , Figure 4). The rC-lobe contains at least one glycan, likely attached to Asn⁴⁷⁹ (C_1 , Figure 4), because this site is always utilized in natural hLF [11]. C_2 presumably represents the rC-lobe with two glycans, attached to Asn⁴⁷⁹ and Asn⁶²⁴. This implies that Asn⁶²⁴ is glycosylated in 70% of the rC-lobe molecules, whereas this site is only used in 9% of natural hLF [11]. Apparently, lack of the entire N-lobe causes an increase in glycosylation at Asn⁶²⁴, confirming our original hypothesis that glycosylation at Asn⁶²⁴ in natural hLF is limited due to conformational and/or primary sequence constraints [11].

Heterogeneity in the glycan structures may explain for the doublets of rC-lobe derived C_1 and C_2 on non-reduced SDS-PAGE (Figure 3A, 4 and 6) although we can not exclude that variation in disulphide

arrangement had occurred as the C-lobe contains 10 disulfide bonds arranged in a complex way [6]. Alternative disulfide bonding, either during intracellular folding or induced on SDS-PAGE, may occur as a result of lack of stabilizing interactions from the N-lobe. Such interactions between the two lobes do exist in natural hLF [8, 23, 24].

The rN-lobe (N_1 and N_0) was saturated with iron (Figure 6, lanes 3 and 4) similarly to what has been described for full length hLF and N-lobe expressed in 293(S) [15] and BHK cells, respectively [12, 19]. Apparently, the rN-lobe was able to retain the iron bound to it even in the presence of SDS. An equal shift in Mr occurred in iron-saturated hLF and rN-lobe upon the release of iron by boiling (about Mr 8,000; Figure 6), suggesting that the major conformational change upon binding of iron occurs in the N-lobe. This confirms crystallographic studies of hLF, which showed that the major conformational change occurs in the N-lobe [8].

Ying and coworkers reported that the iron-saturated and iron-free 39 kDa N-terminal tryptic fragment migrated equally on SDS-PAGE and concluded that the conformational change observed with natural hLF required an intact hLF molecule [25]. It is obvious from our work that this conclusion, which was based on iron-binding studies with a non-intact N-lobe fragment, is not valid as the conformational change of the intact N-lobe upon binding of iron is detected by SDS-PAGE analysis (Figure 6). Unglycosylated rN-lobe was also completely saturated with iron (FeN_0 , Figure 6, lane 3), indicating that the N-linked glycan of the N-lobe is of less importance for the stability of the iron-saturated conformation.

X-ray scattering studies of hLF revealed that structural changes also occur in the C-lobe upon uptake and release of iron [26], which was confirmed by crystallography [8]. This structural change in the C-lobe was not observed in this study as boiled and non-boiled purified rC-lobe migrated on SDS-PAGE with equal Mr (Figure 6, lanes 5 and 6). We can, however, not exclude that conformational changes had occurred in the rC-lobe, but these may not be resistant to SDS or too minor to be determined on SDS-PAGE. Moreover, at this stage we do not have data to support that the rC-lobe is able to bind iron in the iron-binding cleft, similar to observed for the rN-lobe.

Next to specific high-affinity binding of iron in the iron-binding cleft, the low affinity binding of iron or other metals to surface exposed residues may also play a role in hLF physiology [9, 18, 27]. Low-affinity metal binding may account for hLF increasing hydroxyl radical formation [18], polymerization of the molecule under low ionic strength conditions [27] and for the formation of a complex with ceruloplasmin [28]. Our results show that surface-exposed residues in the N-lobe determine the low affinity and ionic binding to chelated iron (Figure 7). The slightly stronger binding of the rN-lobe to both Fe-Chelating Sepharose and Mono S when compared to natural hLF suggests that N-terminal arginines, which determine binding of the protein to Mono S [15], are also involved in binding to chelated iron. This hypothesis was confirmed by the lower affinity of limitedly trypsinized hLF, which lacks N-terminal arginines [22], for Fe-Chelating Sepharose (not shown). Involvement in the binding of chelated iron adds another feature to the N-terminal domain of LF.

In conclusion, the successful expression and initial characterization of the recombinant N- and C-lobe of hLF has further clarified the role of these lobes in the metal-binding, ligand interaction and N-linked glycosylation of hLF.

Acknowledgements

We thank Marianne Kroos (Erasmus University, Rotterdam, The Netherlands) for performing the N-terminal sequencing.

References

1. Anderson BF, Baker HM, Norris GE, Rice DW & Baker EN (1989) Structure of human lactoferrin: crystallographic structure analysis and refinement at 2.8 Å resolution, *J Mol Biol* **209**, 711-734.
2. Nuijens JH, van Berkel PHC & Schanbacher FL (1996) Structure and biological actions of lactoferrin, *Journal of Mammary Gland Biology and Neoplasia* **1**, 285-295.
3. Appelmelk BJ, An YQ, Geerts M, Thijs BG, de Boer HA, MacLaren DM, de Graaff J & Nuijens JH (1994) Lactoferrin is a lipid A-binding protein, *Infect Immun* **62**, 2628-2632.
4. He J & Furmanski P (1995) Sequence specificity and transcriptional activation in the binding of lactoferrin to DNA, *Nature* **373**, 721-724.
5. Mann DM, Romm E & Migliorini M (1994) Delineation of the glycosaminoglycan-binding site in the human inflammatory response protein lactoferrin, *J Biol Chem* **269**, 23661-23667.
6. Metz-Boutigue M, Jolles J, Mazurier J, Schoentgen F, Legrand D, Spik G, Montreuil J & Jolles P (1984) Human lactotransferrin: amino acid sequence and structural comparisons with other transferrins, *Eur J Biochem* **145**, 659-676.
7. Rey MW, Woloshuk SL, de Boer HA & Pieper FR (1990) Complete nucleotide sequence of human mammary gland lactoferrin, *Nucleic Acids Res* **18**, 5288.
8. Baker HM, Anderson BF, Kidd RD, Shewry SC & Baker EN (2000) Lactoferrin three-dimensional structure: a framework for interpreting function, *In Lactoferrin: Structure, Function and Applications* (Shimazaki, K, ed), pp 3-15, Elsevier Science, Amsterdam.
9. Nagasako Y, Saito H, Tamura Y, Shimamura S & Tomita M (1993) Iron-binding properties of bovine lactoferrin in iron-rich solution, *J Dairy Sci* **76**, 1876-1881.
10. Hutchens TW & Yip TT (1991) Metal ligand-induced alterations in the surface structures of lactoferrin and transferrin probed by interaction with immobilized copper(II) ions, *J Chromatogr* **536**, 1-15.
11. van Berkel PH, van Veen HA, Geerts ME, de Boer HA & Nuijens JH (1996) Heterogeneity in utilization of N-glycosylation sites Asn624 and Asn138 in human lactoferrin: a study with glycosylation-site mutants, *Biochem J* **319**, 117-122.
12. Day CL, Stowell KM, Baker EN & Tweedie JW (1992) Studies of the N-terminal half of human lactoferrin produced from the cloned cDNA demonstrate that interlobe interactions modulate iron release, *J Biol Chem* **267**, 13857-13862.
13. Sheth B, Stowell KM, Day CL, Baker EN & Tweedie JW (1994) Cloning and expression of the C-terminal lobe of human lactoferrin, *Adv Exp Med Biol* **357**, 259-263.
14. van Berkel PHC, van Veen HA, Geerts MEJ & Nuijens JH (2002) Characterization of monoclonal antibodies against human lactoferrin, *J Immunol Meth* **267**, 139-150.
15. van Berkel PHC, Geerts MEJ, van Veen HA, Kooiman PM, Pieper F, de Boer HA & Nuijens JH (1995) Glycosylated and unglycosylated human lactoferrins can both bind iron and have identical affinities towards human lysozyme and bacterial lipopolysaccharide, but differ in their susceptibility towards tryptic proteolysis, *Biochem J* **312**, 107-114.
16. Kijlstra A, Kuizenga A, van der Velde M & van Haeringen NJ (1989) Gel electrophoresis of human tears reveals various forms of tear lactoferrin, *Curr Eye Res* **8**, 581-588.
17. Nuijens JH, van Berkel PH, Geerts ME, Hartevelt PP, de Boer HA, van Veen HA & Pieper FR (1997) Characterization of recombinant human lactoferrin secreted in milk of transgenic mice, *J Biol Chem* **272**, 8802-8807.
18. Zhao XY & Hutchens TW (1994) Proposed mechanisms for the involvement of lactoferrin in the hydrolysis of nucleic acids, *Adv Exp Med Biol* **357**, 271-278.
19. Tweedie JW, Bain HB, Day CL, Nicholson HH, Mead PE, Sheth B & Stowell KM (1994) Lactoferrin cDNA. Expression and in vitro mutagenesis, *Adv Exp Med Biol* **357**, 197-208.

20. van Berkel PHC, Geerts MEJ, van Veen HA, Mericskay M, de Boer HA & Nuijens JH (1997) The N-terminal stretch Arg2 Arg3, Arg4 and Arg5 of human lactoferrin is essential for binding to heparin, bacterial lipopolysaccharide, human lysozyme and DNA, *Biochem J* **328**, 145-151.
21. Ellass-Rochard E, Roseanu A, Legrand D, Trif M, Salmon V, Motas C, Montreuil J & Spik G (1995) Lactoferrin-lipopolysaccharide interactions: involvement of the 28-34 loop region of human lactoferrin in the high-affinity binding of Escherichia coli 055B5 lipopolysaccharide, *Biochem J* **312**, 839-846.
22. Legrand D, van Berkel PHC, Salmon V, van Veen HA, Slomianny MC, Nuijens JH & Spik G (1997) The N-terminal Arg2, Arg3 and Arg4 of human lactoferrin interact with sulphated molecules but not with the receptor present on Jurkat human lymphoblastic T-cells, *Biochem J* **327**, 841-846.
23. Legrand D, Mazurier J, Aubert JP, Loucheux MH, Montreuil J & Spik G (1986) Evidence for interactions between the 30 kDa N- and 50 kDa C-terminal tryptic fragments of human lactotransferrin, *Biochem J* **236**, 839-844.
24. Ward PP, Zhou X & Conneely OM (1996) Cooperative interactions between the amino- and carboxyl-terminal lobes contribute to the unique iron-binding stability of lactoferrin, *J Biol Chem* **271**, 12790-12794.
25. Ying L, He J & Furmanski P (1994) Iron-induced conformational change in human lactoferrin: demonstration by sodium dodecyl sulfate-polyacrylamide gel electrophoresis and analysis of effects of iron binding to the N and C lobes of the molecule, *Electrophoresis* **15**, 244-250.
26. Grossmann JG, Neu M, Pantos E, Schwab FJ, Evans RW, Townes AE, Lindley PF, Appel H, Thies WG & Hasnain SS (1992) X-ray solution scattering reveals conformational changes upon iron uptake in lactoferrin, serum and ovo-transferrins, *J Mol Biol* **225**, 811-819.
27. Mantel C, Miyazawa K & Broxmeyer HE (1994) Physical characteristics and polymerization during iron saturation of lactoferrin, a myelopoietic regulatory molecule with suppressor activity, *Adv Exp Med Biol* **357**, 121-132.
28. Pulina MO, Zakharova ET, Sokolov AV, Shavlovski MM, Bass MG, Solovyov KV, Kokryakov VN & Vasilyev VB (2002) Studies of the ceruloplasmin-lactoferrin complex, *Biochem Cell Biol* **80**, 35-39.

Chapter 5

Large scale production of recombinant human lactoferrin in the milk of transgenic cows

Patrick H.C. van Berkel^{1*}, Mick M. Welling², Marlieke Geerts¹, Harrie A. van Veen¹, Bep Ravensbergen³, Mourad Salaheddine¹, Ernest K. J. Pauwels², Frank Pieper¹, Jan H. Nuijens¹ and Peter H. Nibbering³

The limited capacity of current bioreactors has led the biopharmaceutical industry to investigate alternative protein expression systems. The milk of transgenic cattle may provide an attractive vehicle for large-scale production of biopharmaceuticals, but there have been no reports on the characteristics of such recombinant proteins. Here we describe the production of recombinant human lactoferrin (rhLF), an iron-binding glycoprotein involved in innate host defense, at gram per liter concentrations in bovine milk. Natural hLF from human milk and rhLF had identical iron-binding and -release properties. Although natural hLF and rhLF underwent differential N-linked glycosylation, they were equally effective in three different *in vivo* infection models employing immunocompetent and leukocytopenic mice, and showed similar localization at sites of infection. Taken together, the results illustrate the potential of transgenic cattle in the large-scale production of biopharmaceuticals.

Lactoferrin, a single-chain, metal-binding glycoprotein of 77 kDa, is a component of the innate host defense of mammals and is produced and released by mucosal epithelial cells and neutrophils¹. It consists of two highly homologous lobes, designated the N and C lobes, each of which can bind a single ferric ion concomitantly with one bicarbonate². Human lactoferrin (hLF) has antibacterial³, antifungal⁴, anti-endotoxin⁵, and antiviral⁶ activities. In addition, hLF interacts with host cells to modulate the inflammatory process and innate host defense¹. Finally, lactoferrin in milk might play a role in iron absorption and/or excretion in newborns, as well as in promotion of intestinal cell growth¹. On the basis of the many biological activities of hLF, researchers have considered a wide variety of possible applications in human health care, such as prophylaxis and treatment of infectious and inflammatory diseases. For these purposes, however, a recombinant source of hLF is required that avoids the limitations of bioreactor capacity⁷. Large-scale production of therapeutic proteins in the milk of transgenic cattle may be a cost-effective alternative to production of recombinant proteins through cell culture or fermentation. Here we report on the generation of transgenic cows expressing recombinant human lactoferrin (rhLF) in their milk, and on the properties of rhLF as compared with natural hLF from human milk.

Results and discussion

Recombinant hLF is expressed at high concentrations in bovine milk. We obtained, by microinjection⁸, transgenic cattle lines 8778, 8783, 8785, and 8793 harboring the genomic hLF gene under regulatory control of the bovine α S1-casein promoter⁹. Expression levels in lactation-induced milk of the various lines are listed in Table 1. We detected similar levels, of about 0.8, 0.4, 3.0, and 2.0 g/l, in calving-induced milk of 8778, 8783, 8785, and 8793, respectively.

Expression levels of recombinant hLF remained consistent throughout the lactation period of 280 days. Milk parameters such as total milk output, cell counts, and total protein, fat, and lactose were within the normal ranges and appeared unaffected by the expression of the transgene (data not shown).

Recombinant and natural hLF are structurally and functionally similar. Information about the functional and structural features of transgenic proteins obtained from the milk of larger mammals is limited, except for a few reports describing protein C (ref. 10) and antithrombin III (ref. 11) production. Recombinant hLF purified from bovine milk was subjected to analytical Mono S chromatography⁹, which discriminates between hLF and bovine lactoferrin (bLF). The rhLF preparation was essentially free of bLF (Fig. 1A). Both rhLF and natural hLF eluted from the column at 0.7 M NaCl, whereas purified bLF eluted at 0.8 M. Enzyme-linked immunosorbent assay (ELISA) analysis indicated that rhLF preparations contained less than 0.1% (w/w) bLF. N-terminal sequencing confirmed the identity of rhLF and showed that the N-terminus of the protein was intact. Comparison of rhLF and natural hLF on SDS-PAGE showed that the relative molecular mass of rhLF was about 1–2 kDa smaller than that of natural hLF (Fig. 1B). After full deglycosylation⁹ with N-glycosidase F, we saw no difference in molecular mass and found that only rhLF was sensitive to digestion with endoglycosidase H (Fig. 1B). Monosaccharide composition analysis of the two preparations indicated that rhLF contained relatively more mannose than did natural hLF (Table 2). Hence, the difference in molecular mass between rhLF and natural hLF resides in differential N-linked glycosylation: natural hLF contains only complex-type glycans, whereas rhLF also contains oligomannose- and/or hybrid-type glycans. Monosaccharide analysis also showed that the N-linked gly-

¹Pharming, Leiden, The Netherlands. ²Department of Radiology, Division of Nuclear Medicine, and

³Department of Infectious Diseases, Leiden University Medical Center, Leiden, The Netherlands.

*Corresponding author (p.berkel@pharming.com).

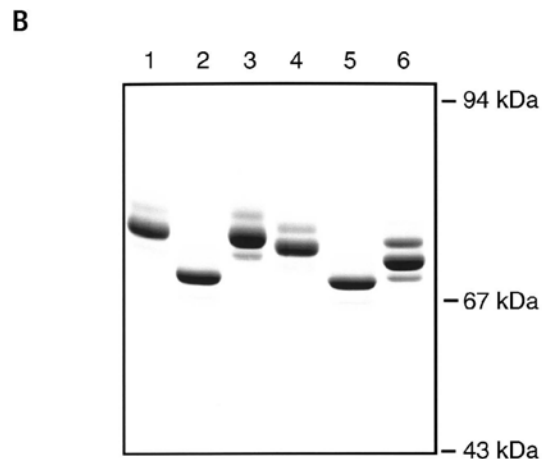
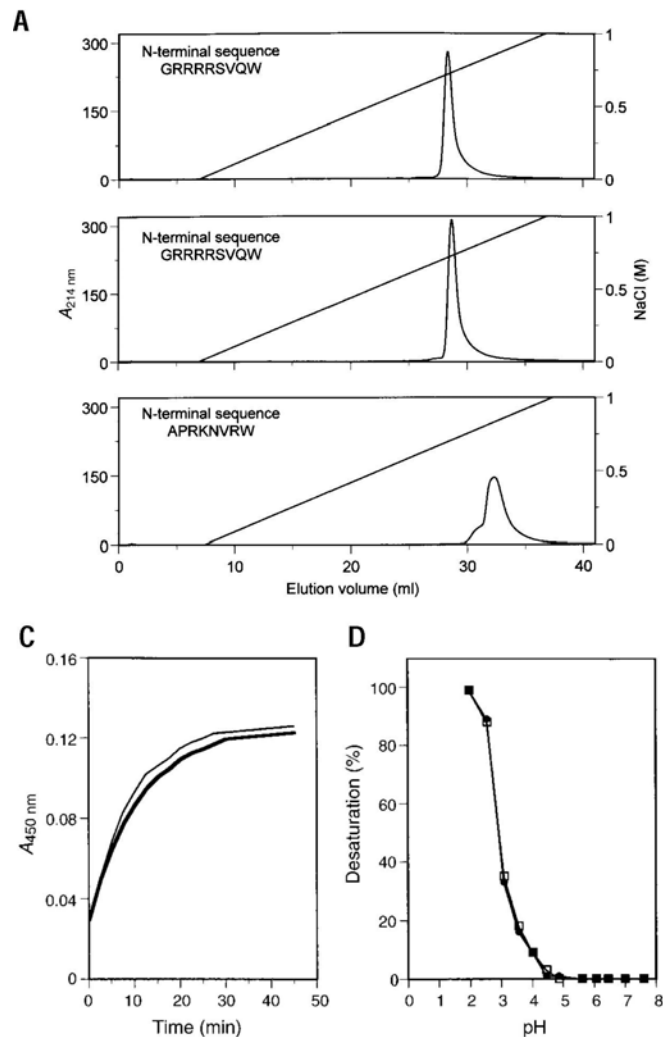

Figure 1. Characterization of rhLF isolated from bovine milk. (A) Mono S chromatography of purified lactoferrins. Purified rhLF (top), natural hLF (middle), and bLF (bottom) (100 μ g each) were applied to Mono S HR 5/5 as described¹⁴. The left and right abscissa indicate the absorption at 214 nm and the NaCl molar concentration (M), respectively. N-terminal protein sequencing results are shown using the standard one-letter codes for amino acids. (B) SDS-PAGE of rhLF and natural hLF. Natural hLF (lanes 1–3) and rhLF (lanes 4–6) were analyzed untreated (lanes 1 and 4) and after treatment with N-glycosidase F (lanes 2 and 5) or endoglycosidase H (lanes 3 and 6) on 7.5% (w/v) SDS-PAGE. All lanes contain 10 μ g of protein. Numbers on the right (kDa) indicate the migration of protein standards. (C) Iron-binding kinetics of rhLF (thin line) and natural hLF (thick line). Results are means of three independent experiments (s.d. < 5%). (D) pH-dependent desaturation of iron-saturated rhLF (\bullet) and natural hLF (\square). The percentage desaturation was calculated by reference to iron-saturated hLF diluted in 0.15 M NaCl.

cans of rhLF contain N-acetylgalactosamine next to galactose, and less sialic acid and fucose than do the glycans of natural hLF. Substitution of galactose with N-

Table 1. Expression of rhLF in milk of distinct transgenic cattle lines

Line	Sex F ₀	rhLF expression in F ₀ (g/l)	Offspring (F ₁)	rhLF expression in F ₁ (g/l)
8778	Female	0.8	8811	0.9
8783	Male	–	8812	0.4
			8818	0.3
8785	Male	–	710	2.8
			712	2.5
			714	2.3
			715	2.3
8793	Male	–	883	1.6
			887	1.6
			888	2.0

Transgenic cows (founders (F₀) or offspring (F₁)) were induced to lactate by hormone treatment. Milk samples were collected for the analysis of rhLF concentration by ELISA. Expression levels represent the mean of at least five milkings during a lactation period of at least 14 days.

acetylgalactosamine has also been observed in human antithrombin III produced in goat milk¹¹. The two most prominent functional activities of hLF, iron binding and release and antibacterial activity¹, were investigated for rhLF and natural hLF. The iron-binding (Fig. 1C) and iron-release characteristics (Fig. 1D) of rhLF and natural hLF were highly similar, in agreement with our previous observation of rhLF isolated from the milk of transgenic mice⁹.

Table 2. Monosaccharide composition of rhLF and natural hLF

Monosaccharide	rhLF		Natural hLF	
	Batch 1	Batch 2	Batch 1	Batch 2
Fuc	0.3	0.2	1.8	1.8
Man	3.0	3.0	3.0	3.0
Gal	0.2	0.2	1.8	2.0
GlcNAc	1.6	1.7	2.8	3.3
GalNAc	0.5	0.6	–	–
Neu5Ac	0.2	0.1	0.9	1.0

Results are expressed relatively to the amount of mannose, which was arbitrarily set at 3.0. Fuc, fucose; Man, mannose; Gal, galactose; GlcNAc, N-acetylglucosamine; GalNAc, N-acetylgalactosamine; Neu5Ac, N-acetyl-neuraminic acid.

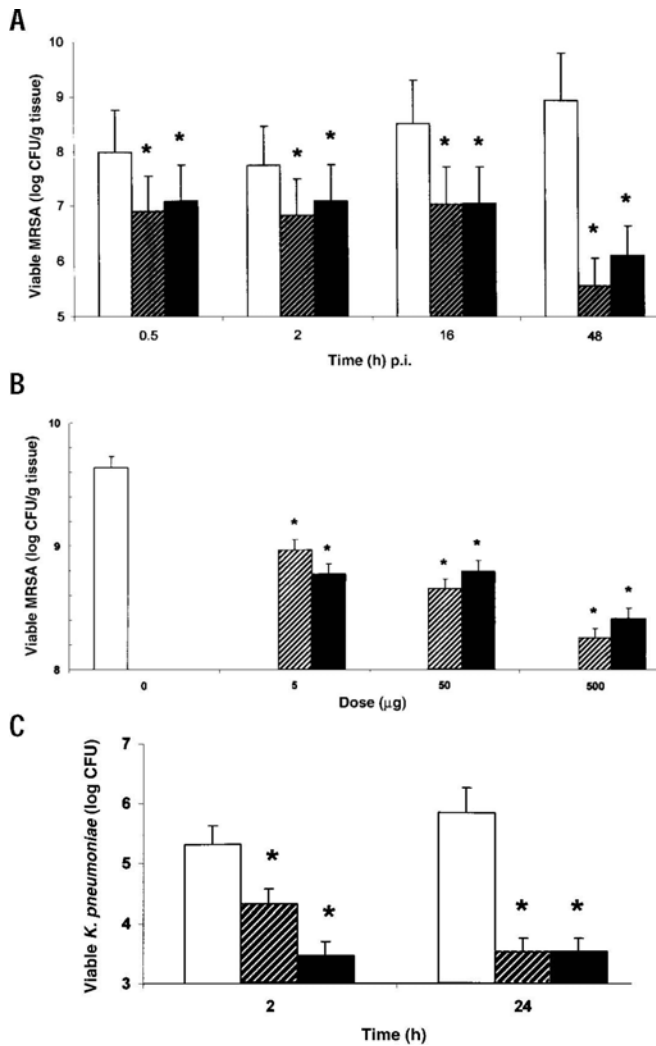

Figure 2. Effect of rhLF and natural hLF on experimentally induced infections in mice. (A) Mice infected with multidrug-resistant *S. aureus* were injected with 50 µg rhLF (hatched bars), natural hLF (black bars), or BSA (white bars). At the indicated time points, the number of CFU in the thigh muscle homogenates was determined microbiologically. Values are means (\pm s.d.) of CFU per gram of thigh muscle ($n = 3$). (B) Cyclophosphamide-treated mice, infected with multidrug-resistant *S. aureus*, were injected with various amounts (range: 0–500 µg/mouse) of rhLF (hatched bars), natural hLF (black bars) or BSA (white bars). After 24 h, the number of viable bacteria was determined microbiologically. Values are means (\pm s.d.) of CFU per gram of thigh muscle ($n = 4$). (C) Mice, intraperitoneally infected with *K. pneumoniae*, were injected with 50 µg of rhLF (hatched bars), natural hLF (black bars), or BSA (white bars). At 2 and 24 h after injection of these proteins, the number of viable bacteria in the peritoneal cavity was determined microbiologically. Values are means (\pm s.d.) of CFU per lavage ($n = 4$). An asterisk indicates a significant difference of $P < 0.05$ in Figure 2A, B, and $P < 0.01$ in Figure 2C, between mice injected with rhLF or natural hLF and mice injected with BSA.

We have recently reported that natural hLF was highly effective against experimental infections with multidrug-resistant *S. aureus* in mice³. Comparison of rhLF and natural hLF in this assay showed that both reduced the number of viable bacteria equally well (Fig. 2A). A significant (Mann-Whitney U-test, $P < 0.05$) bactericidal effect became

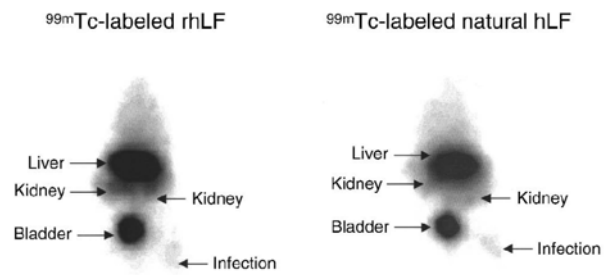

Figure 3. Scintigrams for ^{99m}Tc-labeled rhLF and ^{99m}Tc-labeled natural hLF in mice infected (thigh muscle) with multidrug-resistant *S. aureus*. Mice infected with *S. aureus* were injected with 10 µg of ^{99m}Tc-labeled hLF, and 60 min later, scintigrams were prepared using a planar low energy general purpose camera (Toshiba, Tokyo, Japan)^{3,15}.

apparent at 30 min after a single injection of 50 µg of rhLF or natural hLF per mouse; maximum effects of more than 99% reduction in the percentage of viable bacteria were reached at 24–48 h. We also compared the in vivo antibacterial activity of rhLF and natural hLF in two models in which hLF had not been tested before: a leukocytopenic model and a peritoneal infection model. In leukocytopenic mice with a tenfold-reduced number of circulating leukocytes, we saw maximum bactericidal effects 24 h after a single injection with 500 µg of hLF per mouse (Fig. 2B). This indicates that hLF is also effective against experimental bacterial infections in immunocompromised hosts. Furthermore, a single intravenous injection with 50 µg of rhLF or natural hLF rapidly reduced the number of viable bacteria in the peritoneal cavity of immunocompetent mice infected with *K. pneumoniae* (Fig. 2C); again, we saw no difference between the bactericidal effects of rhLF and natural hLF.

Pharmacological studies using radiolabeled proteins showed that ^{99m}Tc-labeled rhLF and natural hLF were rapidly removed from the circulation of multidrug-resistant, *S. aureus*-infected mice with a $t_{1/2}$ value of 24 ± 3 min ($n = 4$) and 21 ± 3 min ($n = 4$), respectively. The two hLF preparations were removed from the circulation both via the liver and intestines and via the kidneys and bladder (Fig. 3). Within 5 min after injection, we observed a significant amount of radioactivity ($\sim 2\%$ of the injected dose) at the site of infection. After 60 min, we still detected similar amounts of radiolabeled rhLF and natural hLF at the site of infection (Fig. 3).

Conclusions

We describe here the expression of rhLF in the milk of transgenic cows at concentrations of up to 3 g/l. The protein was highly similar to natural hLF when analyzed for its two most prominent biological activities, iron binding and release and antibacterial activity. The differential N-linked glycosylation of rhLF and natural hLF apparently did not affect the proteins' biological activities either in vitro or in vivo. One might have theoretically predicted differences in vivo, considering the relatively low degree of sialylation and the presence of exposed mannose on rhLF, which might

result in faster clearance and reduced in vivo efficacy.

This report illustrates the potential of transgenic cattle as bioreactors in terms of capacity. With the observed expression level and an annual output of 8,000 liters of milk per cow, one cow of line 8785 produces 24 kg crude rhLF per year. Hence, a few hundred animals could supply thousands of kilograms of the product annually, and changes in dosing regimes, market projections, and additional applications of the biopharmaceutical can easily be met by expansion of the herd. Until recently, the limitations of using transgenic cattle as bioreactors were the inefficiency of microinjection to generate founders⁸ and the lengthy time lines. These issues have been markedly improved by the introduction of nuclear transfer (NT) as a means to generate transgenic cattle¹². NT is much more efficient than microinjection and allows the sex of founders to be predetermined. Thus, mini-herds consisting of genetically identical transgenic cows can rapidly be generated, providing quick access to large quantities of milk, especially when milk is obtained from young animals after induction with hormones. These data collectively provide strong arguments for the use of transgenic cattle as a serious alternative vehicle for biopharmaceutical protein production.

Experimental protocol

Proteins. Natural hLF was purified from human milk as described⁹. BSA was obtained from Sigma (St. Louis, MO).

Induction of lactation. Lactation was induced at the age of six to eight months by subcutaneous injections with 25 mg/kg/day medroxyprogesterone acetate (Vétoquinol, Lure Cedex, France) and 7.5 mg/kg/day estradiol benzoate (Intervet, Boxmeer, The Netherlands) for seven days. This course was followed by a two-day period of rest after which 4 mg/day dexamethasone (Intervet) was given intramuscularly for three days. Milking attempts were initiated on the second day of dexamethasone treatment. Cows were milked twice daily. When milking was stopped, intramuscular injections of spiramycin were administered for three days (30 mg/kg) to prevent mastitis. Genetic modification studies on cows were approved by the Committee for Ethical Evaluation of Genetic Modification of Animals (Schroten Committee), installed by the Dutch government (The Hague, The Netherlands) and chaired by E. Schroten (University of Utrecht, The Netherlands), permission number P1322.

Purification of rhLF from bovine milk. The lactoferrin fraction from transgenic bovine skimmed milk, containing rhLF and bLF, was captured on S Sepharose (Amersham Pharmacia Biotech, Uppsala, Sweden). After extensive washing, lactoferrin was eluted with high salt, concentrated, buffer exchanged to 20 mM sodium phosphate pH 7.5 + 0.1 M NaCl, and filtered (0.22 µm). Then, Tween 80 (1%) and tri-N-butylphosphate (0.3%) were added for 15 ± 3 h at 25 ± 1°C to inactivate enveloped viruses. Next, rhLF was separated from added chemicals and bLF by cation-exchange chromatography on MacroPrep High S Support (Bio-Rad Laboratories, Hercules, CA) by stepwise elution with increased NaCl. Fractions containing only rhLF were pooled, concentrated, and filtered through two Planova hollow 15-nm fibers placed in series (Asahi, Tokyo, Japan). The final rhLF solution was concentrated, diafiltered against saline (0.9% NaCl), filtered (0.1 µm), and stored in vials. Analytical Mono S (Amersham Pharmacia Biotech) chromatography of purified rhLF was performed as described⁹.

ELISA of hLF and bLF. Recombinant hLF and natural hLF were quantified by hLF-specific ELISA¹³. The ELISA specific for bLF was done similarly using affinity-purified rabbit anti-bLF and horseradish peroxidase-conjugated affinity-purified rabbit anti-bLF as coating and conjugate, respectively. Affinity-purified anti-bLF was absorbed with hLF-Sepharose to remove hLF crossreacting antibodies.

SDS-PAGE of rhLF and natural hLF. Samples of rhLF and natural hLF were digested either with N-glycosidase F, as described previously⁹, or with endoglycosidase H (2 milliunits; Roche, Almere, The Netherlands) for 16 h at 37°C in 100 mM sodium citrate, pH 5.5, 0.05% wt/vol SDS. Treated and untreated (control) samples were boiled for 5 min in nonreducing sample buffer and then analyzed on 7.5% (w/v) SDS-PAGE. Proteins were stained with Coomassie brilliant blue.

Iron-binding and iron-desaturation studies on rhLF and natural hLF. To study iron binding, a freshly prepared iron citrate solution was added to rhLF and natural hLF, which were both 8% saturated with iron. The increase in absorbance at 450 nm (A450 nm) was measured every 30 s for 45 min, at which time saturation with iron was essentially complete (>98%). To study pH-dependent desaturation of iron-saturated rhLF and natural hLF, these preparations were diluted in buffers of varying pH and the A465 nm was measured after incubation for 21 h at 20°C (ref. 9).

Monosaccharide composition of rhLF and natural hLF. Proteins were lyophilized in the presence of 100 nmol mannitol and methanolized for 24 h at 85°C in 1.0 M HCl (ref. 16). Samples were neutralized with silver carbonate and N-acetylated with acetic anhydride. After centrifugation (5 min, 20,000g, 25°C), the supernatant was evaporated and dried. The methylglycosides were tri-methylsilylated and analyzed by gas-liquid chromatography with a CP Sil 5CB column (Chrompack, Walton on Thames, UK) and flame-ionization detection.

Bacteria. A multidrug-resistant strain of *Staphylococcus aureus* described previously³ (a clinical isolate; Department of Infectious Diseases, Leiden University Medical Center) was used in this study. *Klebsiella pneumoniae* 43816 was purchased from the American Type Culture Collection (Rockville, MD). Bacteria were cultured overnight in nutrient broth at 37°C, diluted in brain-heart infusion broth, and cultured for an additional 2 h in a shaking water bath at 37°C. Stocks of bacteria (1×10^8 colony-forming units (CFU)/ml) were then prepared and stored at -20°C.

Effect of rhLF and natural hLF on experimentally induced infections. Specific pathogen-free male Swiss mice weighting 20–25 g (Broekman Institute, Someren, The Netherlands) were infected by intramuscular injection with approximately 1×10^6 CFU of multidrug-resistant *S. aureus*; 24 h thereafter, 50 µg rhLF, natural hLF, or BSA was injected intravenously. At 0.5, 2, 16, and 48 h after injection of proteins, mice were killed and their thigh muscles removed, weighed, and then homogenized. Next, the number of CFU in the homogenates was determined microbiologically as described in detail elsewhere³. Where indicated, experiments were carried out in mice injected intraperitoneally with 200 mg cyclophosphamide (Endoxan-ASTA, Dagra, Utrecht, The Netherlands) three days prior to the induction of leukocytopenia. Blood leukocyte counts were taken from randomly selected mice to confirm leukocytopenia. Cyclophosphamide-treated mice were infected intra-muscularly with approximately 1×10^6 CFU of multidrug-resistant *S. aureus*; 24 h thereafter, mice were injected with various amounts (range: 0–500 µg per mouse) of rhLF, natural hLF, or BSA. After 24 h, the number of viable bacteria was determined microbiologically. In the

K. pneumoniae model, mice were infected intraperitoneally with approximately 1×10^6 CFU of *K. pneumoniae*; 24 h thereafter, 50 μ g of rhLF, natural hLF, or BSA was injected intravenously. At 2 and 24 h after injection of these proteins, mice were killed and their peritoneal cavities were lavaged with 4 ml of ice-cold PBS supplemented with 50 units/ml heparin. The number of viable bacteria was determined microbiologically. All mouse studies were done in compliance with Dutch laws relating to the conduct of animal experiments and were approved by the Dutch Experimental Animal Committees DEC 98120 and DEC 99097, Leiden University (Secretary, P.G.J. Reuzel, P.O. Box 2081, Leiden, The Netherlands).

References

- Nuijens, J.H., van Berkel, P.H.C. & Schanbacher, F.L. Structure and biological actions of lactoferrin. *J. Mammary Gland Biol. Neoplasia* 1, 285–295 (1996).
- Anderson, B.F., Baker, H.M., Norris, G.E., Rice, D.W. & Baker, E.N. Structure of human lactoferrin: crystallographic structure analysis and refinement at 2.8 Å resolution. *J. Mol. Biol.* 209, 711–734 (1989).
- Nibbering, P.H. et al. Human lactoferrin and peptides derived from its N terminus are highly effective against infections with antibiotic-resistant bacteria. *Infect. Immun.* 69, 1469–1476 (2001).
- Soukka, T., Tenovuo, J. & Lenander, L.M. Fungicidal effect of human lactoferrin against *Candida albicans*. *FEMS Microbiol. Lett.* 69, 223–228 (1992).
- Zhang, G.H., Mann, D.M. & Tsai, C.M. Neutralization of endotoxin in vitro and in vivo by a human lactoferrin-derived peptide. *Infect. Immun.* 67, 1353–1358 (1999).
- Hasegawa, K., Motosuchi, W., Tanaka, S. & Dosako, S. Inhibition with lactoferrin of in vitro infection with human herpes virus. *Jpn. J. Med. Sci. Biol.* 47, 73–85 (1994).
- Garber, K. Biotech industry faces new bottleneck. *Nat. Biotechnol.* 19, 184–185 (2001).
- Krimpenfort, P. et al. Generation of transgenic dairy cattle using ‘in vitro’ embryo production. *Biotechnology (NY)* 9, 844–847 (1991).
- Nuijens, J.H. et al. Characterization of recombinant human lactoferrin secreted in milk of transgenic mice. *J. Biol. Chem.* 272, 8802–8807 (1997).
- Velander, W.H. et al. High-level expression of a heterologous protein in the milk of transgenic swine using the cDNA encoding human protein C. *Proc. Natl. Acad. Sci. USA* 89, 12003–12007 (1992).
- Edmunds, T. et al. Transgenically produced human antithrombin: structural and functional comparison to human plasma-derived antithrombin. *Blood* 91, 4561–4571 (1998).
- Brink, M.F., Bishop, M.D. & Pieper, F.R. Developing efficient strategies for the generation of transgenic cattle which produce biopharmaceuticals in milk. *Theriogenology* 53, 139–148 (2000).
- van Berkel, P.H., van Veen, H.A., Geerts, M.E., de Boer, H.A. & Nuijens, J.H. Heterogeneity in utilization of N-glycosylation sites Asn624 and Asn138 in human lactoferrin: a study with glycosylation-site mutants. *Biochem. J.* 319, 117–122 (1996).
- van Berkel, P.H.C. et al. Glycosylated and unglycosylated human lactoferrins can both bind iron and have identical affinities towards human lysozyme and bacterial lipopolysaccharide, but differ in their susceptibility towards tryptic proteolysis. *Biochem. J.* 312, 107–114 (1995).
- Welling, M.M., Paulusma-Annema, A., Balter, H.S., Pauwels, E.K. & Nibbering, P.H. Technetium-99m labelled antimicrobial peptides discriminate between bacterial infections and sterile inflammations. *Eur. J. Nucl. Med.* 27, 292–301 (2000).
- Kamerling, J.P. & Vliegthart, J.F.G. Carbohydrates. In *Mass spectrometry*. (ed. Lawson, A.M.) 176–263 (Walter de Gruyter, Berlin, 1989).

Acknowledgments

We wish to acknowledge all the colleagues at Pharming who contributed to the lactoferrin project. We thank J. Kamerling and G. Gerwig (University of Utrecht, The Netherlands) for the monosaccharide composition analysis.

Competing interests statement

The authors declare competing financial interests: see the *Nature Biotechnology* website (<http://biotech.nature.com>) for details.

Received 18 October 2001; accepted 19 February 2002

Chapter 6

The protein structure of recombinant human lactoferrin produced in the milk of transgenic cows closely matches the structure of human milk-derived lactoferrin[★]

Ellen A. J. Thomassen^{1,‡}, Harrie A. van Veen^{2,*‡}, Patrick H. C. van Berkel^{2,3}, Jan H. Nuijens² & Jan Pieter Abrahams¹

¹*Biophysical Structural Chemistry, Leiden Institute of Chemistry, Leiden University, Einsteinweg 55, 2333 CC Leiden, The Netherlands*

²*Pharming, Archimedesweg 4, 2333 CN Leiden, The Netherlands*

³*Current address: Genmab, Yalelaan 60, 3584 CM, Utrecht, The Netherlands*

Received 1 November 2004; accepted 27 February 2005

Key words: iron-binding, lactoferrin, transgenic cows

Abstract

Human lactoferrin (hLF) is an iron-binding glycoprotein involved in the host defence against infection and excessive inflammation. As the availability of (human milk-derived) natural hLF is limited, alternative means of production of this biopharmaceutical are extensively researched. Here we report the crystal structure of recombinant hLF (rhLF) expressed in the milk of transgenic cows at a resolution of 2.4 Å. To our knowledge, the first reported structure of a recombinant protein produced in milk of transgenic livestock. Even though rhLF contains oligomannose- and hybrid-type N-linked glycans next to complex-type glycans, which are the only glycans found on natural hLF, the structures are identical within the experimental error (r.m.s. deviation of only 0.28 Å for the main-chain atoms). Of the differences in polymorphic amino acids between the natural and rhLF variant used, only the side-chain of Asp⁵⁶¹ could be modeled into the rhLF electron density map. Taken together, the results confirm the structural integrity of the rhLF variant used in this study. It also confirms the validity of the transgenic cow mammary gland as a vehicle to produce recombinant human proteins.

Abbreviations: LF – lactoferrin; hLF – human lactoferrin; natural hLF – hLF purified from human milk; rhLF – recombinant hLF; iron-saturated rhLF – rhLF that has been completely saturated with iron *in vitro*

Introduction

Lactoferrin (LF) is a metal-binding glycoprotein of 77 kDa belonging to the transferrin family

(Anderson et al., 1989). The molecule is found in milk, tears, saliva, bronchial, intestinal and other secretions, but also in the secondary granules of neutrophils (Nuijens et al., 1996). Based on the many reports of its antimicrobial and anti-inflammatory activity *in vitro*, LF is thought to be involved in the host defense against infection and excessive inflammation, most notably at mucosal surfaces (Nuijens et al., 1996). Antimi-

*Author for correspondence

E-mail: h.veen@pharming.com

‡These authors have contributed equally to this paper.

★The PDB-code of recombinant human lactoferrin is 2BJJ

icrobial activities of LF include bacteriostasis by the sequestration of free iron (Reiter et al., 1975) and bactericidal activity by destabilization of the cell-wall (Ellison III et al., 1988; Ellison III & Giehl, 1991). Anti-inflammatory actions of LF include inhibition of hydroxyl-radical formation (Sanchez et al., 1992), of complement activation (Kijlstra & Jeurissen, 1982) and of cytokine production (Zucali et al., 1989) as well as neutralization of lipopolysaccharide (LPS) (Lee et al., 1998). Due to these biological activities of LF, a wide variety of applications in human health care has been proposed, such as treatment of infectious and inflammatory diseases. As a nutraceutical application, the molecule can be used as a component of clinical nutrition products aimed at the prevention and treatment of gastrointestinal tract infections and inflammations.

The DNA and amino acid sequences of human lactoferrin (hLF) have been determined (Metz-Boutigue et al., 1984; Rey et al., 1990). Human LF consists of a polypeptide chain of 692 amino acids, which is folded into two globular lobes (Anderson et al., 1989). These lobes, designated the N- and C-lobe, share an internal amino acid identity of about 40% (Metz-Boutigue et al., 1984) and are connected by a α -helix. Each lobe folds into α -helix and β -sheet arrays to form domains I and II, respectively, which are connected by a hinge region, creating a deep iron-binding cleft within each lobe. Each cleft binds a single ferric ion with high affinity while simultaneously incorporating a bicarbonate ion (Anderson et al., 1989). Crystallographic studies of hLF have showed that upon binding of iron, domain I of the N- and C-lobe rotates relative to domain II by $\sim 54^\circ$ and $\sim 20^\circ$, respectively, resulting in a more globular closed, and stable conformation of the entire molecule (Baker et al., 2000). Next to the high affinity metal binding in the iron-binding cleft, LF also binds metals with much lower affinity (Nagasako et al., 1993). This occurs at least in part via surface-exposed histidyl residues (Hutchens & Yip, 1991). Whereas some of the biological activities of hLF relate to high or low affinity iron-binding, others are mediated by a positively charged domain located in the N-terminus. This domain binds to negatively charged ligands such as the lipid A portion of LPS (Appelmelk et al., 1994), DNA (He & Furmanski, 1995), heparin (Mann et al., 1994) as

well as other proteins such as lysozyme (van Berkel et al., 1995) and specific receptors (Ziere et al., 1993; Legrand et al., 1997).

Human LF contains three possible N-glycosylation sites, Asn¹³⁸ in the N-lobe and Asn⁴⁷⁹ as well as Asn⁶²⁴ in the C-lobe (Rey et al., 1990), which are utilized in about 94, 100 and 9% of the molecules, respectively (van Berkel et al., 1996).

Recently, the production of recombinant hLF (rhLF) in the milk of transgenic cows was reported (van Berkel et al., 2002). Comparative studies between rhLF and hLF from human milk (natural hLF) revealed identical iron-binding and release properties, and despite differences in N-linked glycosylation, equal effectiveness in various infection models (van Berkel et al., 2002). Here, we report the crystallographic structure of rhLF in its iron-saturated conformation. The structure appeared to be almost identical to the structure reported for iron-saturated natural hLF (Haridas et al., 1995).

Materials and methods

Expression and purification of rhLF

The production and purification of rhLF from the milk of transgenic cows has been described previously (van Berkel et al., 2002). Briefly, a genomic hLF sequence with polymorphic amino acids at position 4 (insertion of Arg), 11 (Ala), 29 (Arg) and 561 (Asp) (van Veen et al., 2004) under control of regulatory elements from the bovine αS_1 casein gene, was introduced into the bovine germline. The resulting transgenic cattle lines showed rhLF expression levels between 0.4 and 2.5 g/L. Purified rhLF was saturated with iron as described (van Berkel et al., 1995).

Crystallization

Crystals were grown by micro-dialysis of rhLF (54 mg/ml in 0.9% NaCl) in a 100 μ l dialysis button against 5 mM sodium phosphate pH 8.5 with 10% (v/v) ethanol at 4°C. Deep red crystals appeared after 4 weeks and grew to dimensions of approximately $3 \times 2 \times 1$ mm³. The protein crystallized in the orthorhombic space-group P2₁2₁2₁, with cell dimensions $a = 55.94$, $b = 97.38$, and $c = 156.30$ Å with 1 molecule in the asymmetric unit.

Data collection

The dialysis button was transferred to 5 mM sodium phosphate pH 8.5 complemented with 20% (v/v) 2-methyl-2,4-pentanediol (MPD) for a week at 4°C to stabilize the crystals, as described (Anderson et al., 1989). Part of a crystal was broken off and mounted in a quartz capillary. X-ray data were collected at room temperature on a FR591 rotating-anode generator equipped with a MAR345 image-plate detector, using Cu K α radiation ($\lambda = 1.5418 \text{ \AA}$). The crystal-to-detector distance was 220 mm and a 0.5° oscillation angle was used per image for a total of 369 images. The intensities were indexed with MOS-FLM (Leslie, 1999) and scaled using SCALA (Evans, 1993). During the scaling process it was observed that a number of the images were not useful, which is most likely caused by a non-uniform quality of the crystal in different directions. These images were left out of the scaling process and not used any further. The resulting data set contained 154 images (77°) and 104905 reflections of which 33492 were unique. The overall completeness of the data set was 96.2%, with a completeness of 97.9% in the highest resolution bin

Table 1. Data-collection and processing parameters

Data collection	rhLF expressed in bovine milk
Crystal dimensions (mm ³)	3 × 2 × 1
Wavelength (Å)	1.5418
Resolution range (Å)	81.65–2.40
Crystal system	orthorhombic
Space group	P2 ₁ 2 ₁ 2 ₁
Unit cell parameters (Å)	$a = 55.94, b = 97.38,$ $c = 156.30$
Total number of reflections	104905
Number of unique reflections	33492
Multiplicity	3.3 (3.3) ^a
R _{sym} ^b	0.057 (0.33)
Completeness (%)	96.2 (97.9)
Average I/σ(I)	8.9 (2.2)
Solvent content (%)	55.51
V _M (Å ³ /Da)	2.8

^aData statistics of the outer resolution shell (2.53–2.40 Å) are given in parentheses, where applicable.

^b $R_{\text{sym}} = \sum_h \sum_i |I_{hi} - \langle I_h \rangle| / \sum_h \sum_i I_{hi}$, where I_{hi} is the intensity of the i th measurement of the same reflection and $\langle I_h \rangle$ is the mean observed intensity for that reflection.

(2.53–2.40 Å). The overall redundancy and R_{sym} were 3.3 and 0.057, respectively. Data collection and processing details are summarized in Table 1.

Structure elucidation and refinement

The structure was determined by molecular replacement, using MOLREP (Vagin & Teplyaev, 1997) and the structure of iron-saturated natural hLF (Haridas et al., 1995) as the search model. The search model included two Fe³⁺ and two CO₃²⁻ ions, but all waters and carbohydrates were omitted. The rotation and translation functions were determined and the best solution had an R-factor of 0.294 and a correlation coefficient of 0.814. Instead of a full molecular replacement, a rigid body refinement could have been performed, after applying an anti-clockwise rotation parallel to the b-axis on the search model, changing a into c and c into $-a$, which would have given the same result. The model was refined using restrained refinement using REFMAC (Murshudov et al., 1997) using 30833 reflections in the resolution range 19.63–2.40 Å (for the refinement statistics see Table 2). Water molecules were built using ARP (Lamzin & Wilson, 1997). Electron density maps were calculated and carbohydrates were fitted into the 2F_o–F_c electron density. The final model was checked using

Table 2. Refinement statistics

Refinement	rhLF expressed in bovine milk
Resolution range (Å)	19.63–2.40
Number of reflections	30833 (1640) ^a
Rfactor ^b	0.18 (0.23)
Protein atoms/waters	5365/54
r.m.s. deviations bonds (Å)	0.013
r.m.s. deviations angles (°)	1.40
Average B value:	
protein/solvent (Å ²)	50.27/39.60
Average B value:	
sugar/Fe ³⁺ /CO ₃ ²⁻ (Å ²)	86.29/31.90/26.43
Ramachandran statistics ^c (%)	86.4/13.0/0.3/0.3

^aData statistics of R_{free} are given in parentheses, where applicable.

^b $R = \sum ||F_{\text{obs}}(hkl)| - |F_{\text{calc}}(hkl)|| / \sum |F_{\text{obs}}(hkl)|$.

^cAccording to the program PROCHECK (Laskowski et al., 1993). The percentages are indicated of residues in the most favoured, additionally allowed, generously allowed and disallowed regions of the Ramachandran plot, respectively.

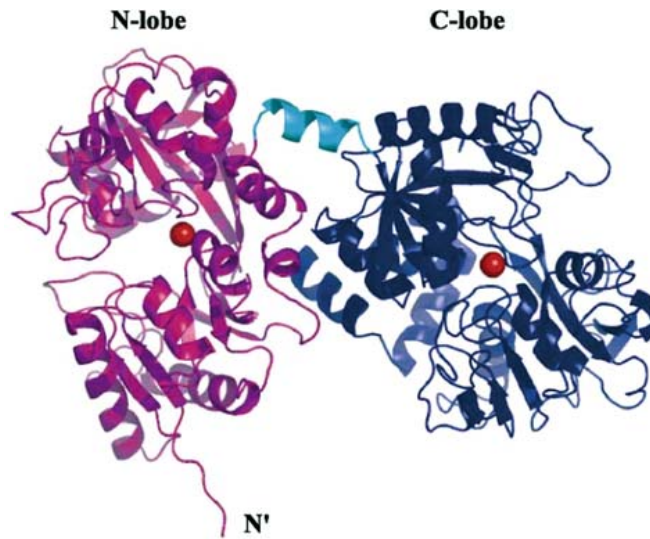

Figure 1. Ribbon diagram of rhLF expressed in the milk of transgenic cows. The N-lobe (residue 1–334) is shown in magenta and the C-lobe (residue 346–692) is shown in dark blue. The α -helix connecting the two lobes is depicted in light blue (residue 335–345). Red spheres show the iron atoms. The figure was prepared with PyMOL (DeLano, 2002).

PROCHECK (Laskowski et al., 1993) and WHATIF (Vriend, 1990).

Structural comparisons

The structure of rhLF isolated from transgenic bovine milk was compared to the structure of iron-saturated natural hLF (PDB-code 1LFG, Haridas et al., 1995), using LSQKAB from the CCP4 program suite (CCP4 suite, 1994). The amino acid residues 1–4 and 1–5 from natural hLF and rhLF, respectively, were disordered and therefore left out of the calculations.

Table 3. Iron site geometry in the N- and C-lobe of rhLF

N-lobe*		C-lobe#	
Atoms	Bond length (Å)	Atoms	Bond length (Å)
Fe–O ⁶¹	2.22	Fe–O ³⁹⁶	2.10
Fe–O ⁹³	1.90	Fe–O ⁴³⁶	1.95
Fe–O ¹⁹³	1.88	Fe–O ⁵²⁹	1.87
Fe–N ²⁵⁴	2.21	Fe–N ⁵⁹⁸	2.36
Fe–O1	2.18	Fe–O1	2.05
Fe–O2	2.24	Fe–O2	2.27

*The ligand atoms in the N-lobe: Asp⁶¹ OD1, Tyr⁹³ OH, Tyr¹⁹³ OH, His²⁵⁴ Nε2, carbonate atoms, O1 and O2.

#The ligand atoms in the C-lobe: Asp³⁹⁶ OD1, Tyr⁴³⁶ OH, Tyr⁵²⁹ OH, His⁵⁹⁸ Nε2, carbonate atoms O1 and O2. The bond lengths are from refinement using Refmac (Murshudov et al., 1997).

Results and discussion

rhLF model

The crystallographic structure of iron-saturated rhLF from transgenic bovine milk refined at 2.4 Å (Figure 1) shows clearly the bilobal structure of hLF with each lobe divided into the two domains and the iron atoms buried in the interdomain clefts. The final model consists of 692 amino acid residues, 54 water molecules, two Fe³⁺ ions, two CO₃²⁻ ions, and two *N*-acetylglucosamine residues that are *N*-linked to Asn¹³⁸ and Asn⁴⁷⁹ (numbering according to Rey et al., 1990). The model has an R-factor of 0.18 and an Rfree of

Table 4. Anion hydrogen bonding distances in the two lobes of rhLF

N-lobe		C-lobe	
Hydrogen bonds	Bond length (Å)	Hydrogen bonds	Bond length (Å)
O1–N ¹²⁴	2.72	O1–N ⁴⁶⁸	2.83
O2–NE ¹²²	2.81	O2–NE ⁴⁶⁶	2.76
O2–NH2 ¹²²	2.88	O2–NH2 ⁴⁶⁶	2.84
O3–N ¹²⁵	3.09	O3–N ⁴⁶⁹	2.92
O3–OG1 ¹¹⁸	2.56	O3–OG1 ⁴⁶²	2.75

The carbonate atoms O1, O2 and O3. The bond lengths are measured in Xfit (McRee, 1999).

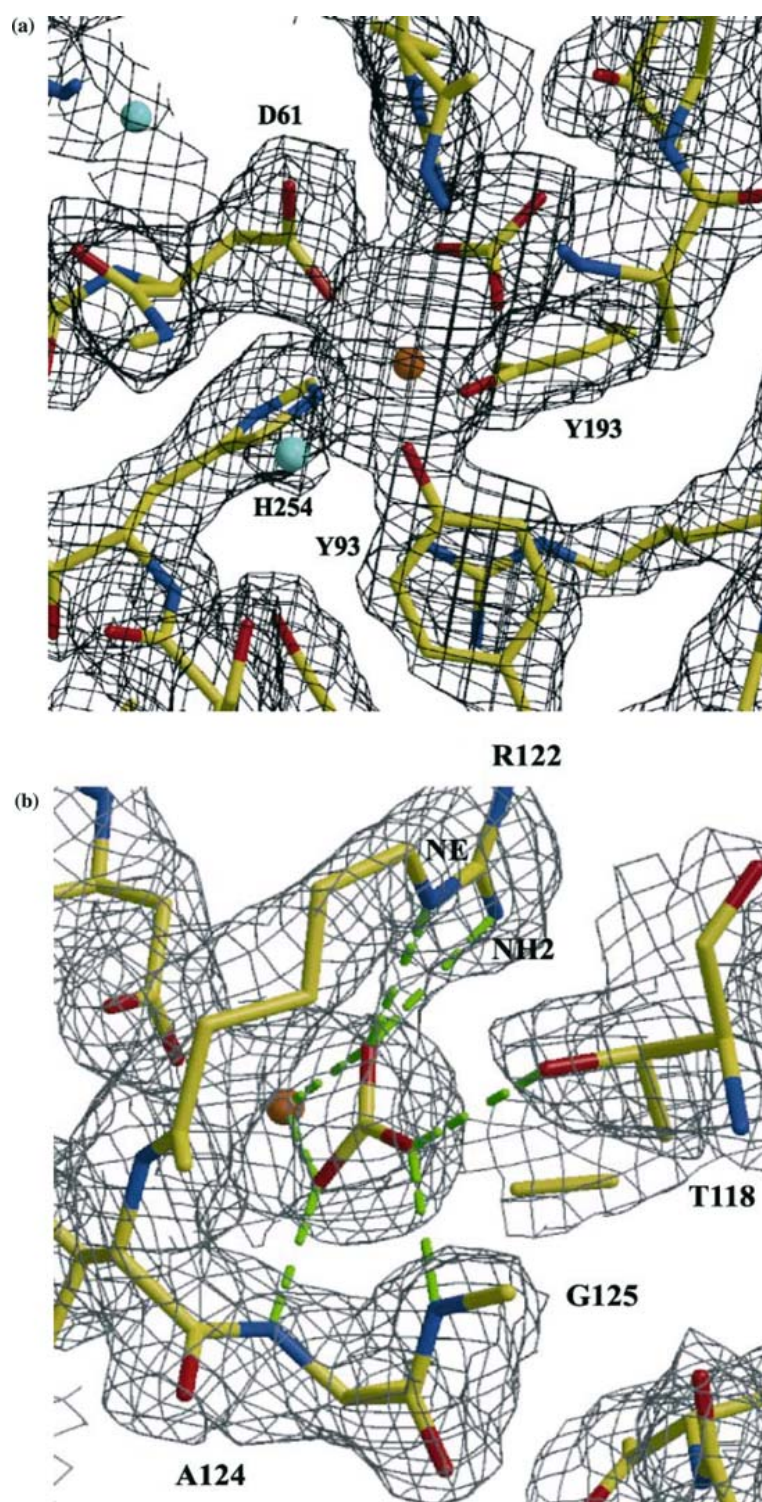

Figure 2. (a) Crystallographic electron density surrounding the ferric ion in the N-lobe of rhLF. The iron binding residues Tyr⁹³, Tyr¹⁹³, Asp⁶¹, His²⁵⁴ and carbonate⁶⁹⁵ are shown in ball-and-stick representation surrounded by the final 2F_o-F_c electron density map contoured at 1.5σ. A red sphere indicates the iron atom and blue spheres indicate waters. 2. (b) Crystallographic electron density surrounding the anion binding site in the N-lobe of rhLF. The anion binding residues Thr¹¹⁸, Arg¹²², Ala¹²⁴ and Gly¹²⁵ are shown in ball-and-stick representation surrounded by the final 2F_o-F_c electron density map contoured at 1.5σ. A red sphere shows the iron⁶⁹³. The pictures were created with Xtalview (McRee, 1999).

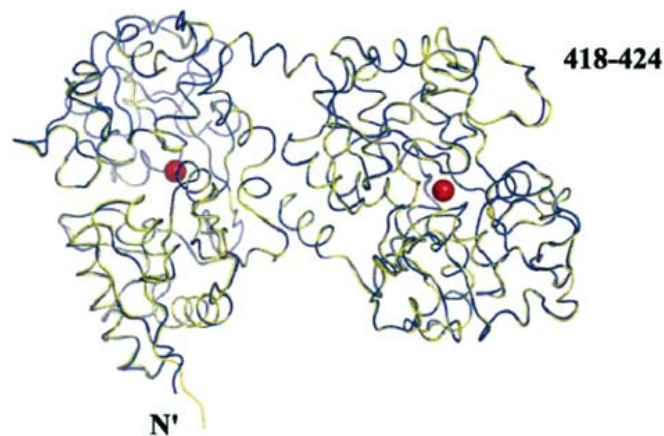

Figure 3. $C\alpha$ superposition of rhLF and natural hLF. rhLF expressed in bovine milk is shown in yellow and natural hLF isolated from human milk in blue. Red spheres show the iron atoms. The figure was prepared with PyMOL (DeLano, 2002).

0.23. The Ramachandran statistics (Table 2) show 86.4% of the residues to be in the “most favored” regions and 13.3% in the “allowed” regions; only 0.3% is in the “disallowed” region, which are residues Leu³⁰⁰ and Leu⁶⁴³. As described before (Haridas et al., 1995), both residues are present in a γ -turn, which seems to be a conserved property of all transferrin structures determined. The N-terminal amino acid stretch (Gly¹-Arg²-Arg³-Arg⁴-Arg⁵) was disordered and could not be modeled. Also the flexible surface loop at residues 418–424 showed no ordered density at 1σ , but at 0.7σ the main-chain and most of the side-chain atoms became visible. The observed disorder and/or flexibility of these two regions is consistent with described previously (Haridas et al., 1995; Sun et al., 1999) and may be explained by lacking of protein interactions. Many of the amino acid residues that are exposed to solvent have disordered side-chains, especially the long side-chains of arginine and lysine residues, and have corresponding high B factors.

Iron and anion binding of rhLF

The structure of rhLF isolated from the milk of transgenic cows was determined in its iron-saturated conformation. As some biological actions of hLF depend on the high-affinity binding of iron, the positions of the ferric ions and anions in the model were closely evaluated. Figure 2a and b show the electron densities surrounding the ferric and carbonate ion, respectively, in the N-lobe of rhLF. The ferric ion is coordinated by Asp⁶¹,

Tyr⁹³, Tyr¹⁹³, His²⁵⁴ and the carbonate ion, which is identical as previous described for iron-saturated natural hLF from human milk (Haridas et al., 1995). In addition, the metal to ligand bond lengths are all close to 2.0 Å (Table 3), which is as expected for coordination of the ferric ion (Haridas et al., 1995). The coordination of the carbonate ion by Thr¹¹⁸, Arg¹²², Ala¹²⁴ and Gly¹²⁵ and hydrogen bonding distances of about 3 Å (Figure 2b, Table 4) also matches with previous reported for natural hLF. The results for the position of the ferric and carbonate ion in the C-lobe of rhLF (Tables 3 and 4) are similar to observed for the N-lobe at least within the accuracy of the present X-ray analysis. Taken together, the coordination and bonding distances of the ferric and carbonate ion in the two lobes of rhLF are equal within the experimental error compared to iron-saturated natural hLF.

Comparison of rhLF and natural hLF

The folding of rhLF is the same as that for natural hLF isolated from human milk (1LFG). The structure of rhLF was superimposed on natural hLF, the r.m.s. deviation in the atomic positions of the main-chain atoms is 0.28 Å, omitting the disordered N-terminus. The superimposed structures are shown in Figure 3, only amino acid residues 418–424 which are in a flexible loop and therefore may adopt alternative conformations and the N-terminus which is completely disordered show differences between residues from rhLF and natural hLF. Most of the amino acid

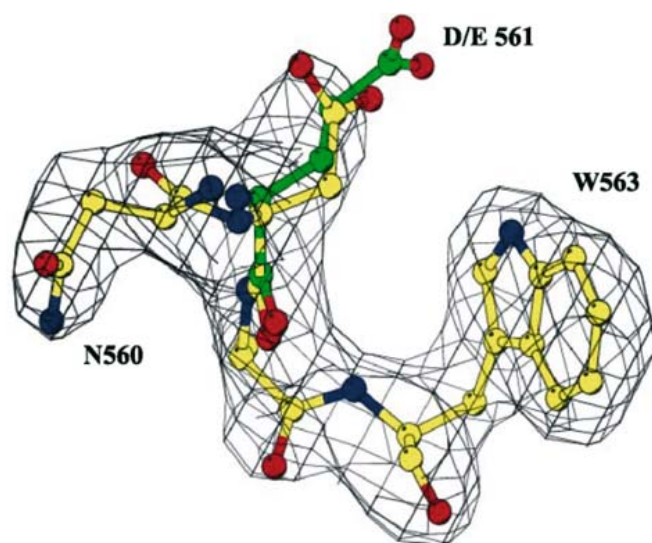

Figure 4. Crystallographic electron density surrounding Asp⁵⁶¹. rhLF amino acid residues Asn⁵⁶⁰, Asp⁵⁶¹, Ala⁵⁶², and Trp⁵⁶³ are shown in ball-and-stick representation with carbon atoms in yellow, surrounded by the final 2F_o-F_c electron density map contoured at 1 σ . At the polymorphic position 561 (numbering according to rhLF) the glutamic acid (E) is shown in ball-and-stick representation with carbon atoms in green. Picture was prepared with BOBSCRIPT (Esnouf, 1999), which is based on MOLSCRIPT (Kraulis, 1991).

side-chains in both structures have similar orientations except for the regions that are disordered or flexible such as the N-terminus, the loop spanning amino acids 418–424 and solvent exposed residues. Previously, polymorphic sites in the hLF coding sequence were reported at amino acid position 4 (deletion of Arg), position 11 (Ala or Thr), position 29 (Arg or Lys) and position 561 (Asp or Glu) (van Veen et al., 2004). Differences in polymorphic sites between rhLF and the natural hLF variant described by Haridas et al. (1995) are at position 4 (- \rightarrow Arg), 29 (Lys \rightarrow Arg) and 561 (Glu \rightarrow Asp). The Arg⁴ residue of rhLF could not be modeled, the N-terminal stretch Gly¹-Arg²-Arg³-Arg⁴-Arg⁵ may however be modeled upon binding of heparin, as Arg²-Arg³-Arg⁴-Arg⁵ is part of the positively charged domain responsible for binding of the ligand (Mann et al., 1994). The side chain of the solvent-exposed Arg²⁹ residue was disordered and could not be modeled. Figure 4 shows the polymorphic site Asp⁵⁶¹ in the 2F_o-F_c density map. The polymorphic sites did neither change the structure of rhLF nor its biochemical activity, when compared to natural hLF (van Berkel et al., 2002).

Glycosylation

Human lactoferrin contains three possible N-glycosylation sites, Asn¹³⁸ in the N-lobe and Asn⁴⁷⁹

as well as Asn⁶²⁴ in the C-lobe (Rey et al., 1990), which are utilized in about 94, 100 and 9% of the molecules, respectively (van Berkel et al., 1996). The glycans of natural hLF are of the sialyl-*N*-acetylglucosaminic type (Spik et al., 1982). Previously, reported was that rhLF from transgenic bovine milk also contains oligomannose and/or hybrid-type glycans (van Berkel et al., 2002).

In the rhLF structure described here, interpretable density for single carbohydrates was present at glycosylation sites Asn¹³⁸ and Asn⁴⁷⁹. The two *N*-acetylglucosamine residues were built into the 2F_o-F_c density map contoured at 0.9 σ . The *N*-acetylglucosamine at position Asn⁴⁷⁹ is shown in Figure 5. Further carbohydrates were insufficiently ordered to extend the model.

Conclusions

The application of rhLF from bovine milk in human health care requires a thorough comparison of the physico-chemical and biological characteristics of the recombinant with the natural form. Here we report that despite the presence of polymorphic sites and differences in N-linked glycosylation, the three-dimensional structure of rhLF closely matches the structure of natural hLF. This observation confirms earlier findings of identical biochemical activity of hLF from

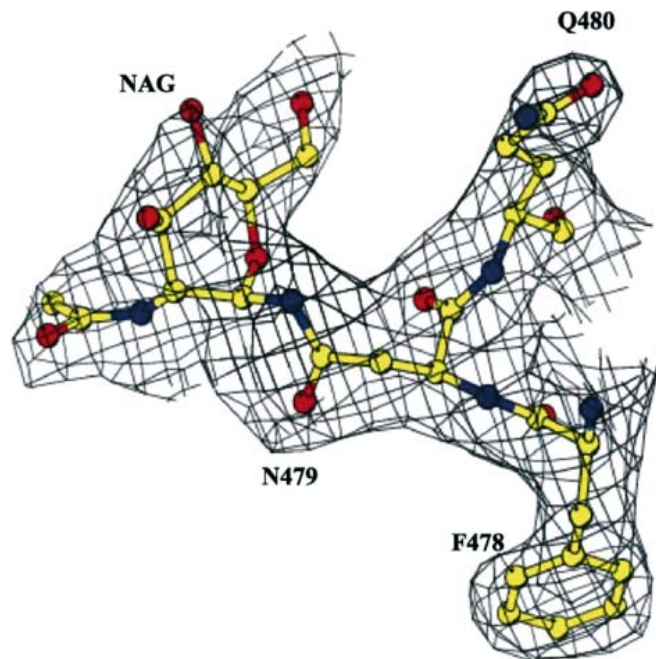

Figure 5. Crystallographic electron density surrounding Asn⁴⁷⁹. Amino acid residues Phe⁴⁷⁸, Asn⁴⁷⁹, and Gln⁴⁸⁰ and *N*-acetylglucosamine (NAG) are shown in ball-and-stick representation surrounded by the final 2F_o-F_c electron density map contoured at 0.9σ. Picture was prepared with BOBSCRIPT (Esnouf, 1999), which is based on MOLSCRIPT (Kraulis, 1991).

both sources, paving the way for safe usage of rhLF in humans. In addition, the results illustrate the potential of transgenic cows to produce recombinant human proteins with a virtually identical structure compared to their human counterparts.

Acknowledgments

We thank R.A.G. de Graaff, N.S. Pannu and M.L. Mannesse for helpful discussions.

References

- Anderson BF, Baker HM, Norris GE, Rice DW and Baker EN (1989) Structure of human lactoferrin: Crystallographic structure analysis and refinement at 2.8 Å. resolution. *J Mol Biol* **209**: 711–734.
- Appelmeik BJ, An YQ, Geerts M, Thijs BG, de Boer HA, MacLaren DM, de Graaff J and Nuijens JH (1994) Lactoferrin is a lipid A-binding protein. *Infect Immun* **62**: 2628–2632.
- Baker HM, Anderson BF, Kidd RD, Shewry SC and Baker EN (2000) Lactoferrin three-dimensional structure: a framework for interpreting function. In: Shimazaki K (ed), *Lactoferrin: Structure, Function and Applications* (pp. 3–15) Elsevier Science, Amsterdam.
- Collaborative Computational Project Number 4 (1994). The CCP4 suite: programs for protein crystallography. *Acta Cryst* **D50**: 760–763.
- DeLano WL (2002) The PyMOL Molecular Graphics System on World Wide Web <http://www.pymol.org>.
- Ellison III RT and Giehl TJ (1991) Killing of gram-negative bacteria by lactoferrin and lysozyme. *J Clin Invest* **88**: 1080–1091.
- Ellison III RT, Giehl TJ and La FF (1988) Damage of the outer membrane of enteric gram-negative bacteria by lactoferrin and transferrin. *Infect Immun* **56**: 2774–2781.
- Esnouf RM (1999) Further additions to MolScript version 1.4, including reading and contouring of electron-density maps. *Acta Cryst* **D55**: 938–940.
- Evans PR (1993) Data collection and processing. In: Dodson E, Moore M, Ralph A and Bailey S (eds), *Proceedings of the CCP4 study weekend 1993* (pp. 114–122) CLRC Daresbury, Warrington.
- Haridas M, Anderson BF and Baker EN (1995) Structure of human diferric lactoferrin refined at 2.2 Å resolution. *Acta Cryst* **D51**: 629–646.
- He J and Furmanski P (1995) Sequence specificity and transcriptional activation in the binding of lactoferrin to DNA. *Nature* **373**: 721–724.
- Hutchens TW and Yip TT (1991) Metal ligand-induced alterations in the surface structures of lactoferrin and transferrin probed by interaction with immobilized copper(II) ions. *J Chromatogr* **536**: 1–15.
- Kijlstra A and Jeurissen SHM (1982) Modulation of the classical C3 convertase of complement by tear lactoferrin. *Immunology* **47**: 263–270.
- Kraulis PJ (1991) MOLSCRIPT: A program to produce both detailed and schematic plots of protein structures. *J Appl Crystallog* **24**: 946–950.

- Lamzin VS and Wilson KS (1997) Automated refinement for protein crystallography. *Methods Enzymol* **277**: 269-305.
- Laskowski RA, MacArthur MW, Moss DS and Thornton JM (1993) PROCHECK: A program to check the stereochemical quality of protein structures. *J Appl Cryst* **26**: 283-291.
- Lee WJ, Farmer JL, Hilty M and Kim YB (1998) The protective effects of lactoferrin feeding against endotoxin lethal shock in germfree piglets. *Infect Immun* **66**: 1421-1426.
- Legrand D, van Berkel PHC, Salmon V, van Veen HA, Slomianny MC, Nuijens JH and Spik G (1997) The N-terminal Arg2, Arg3 and Arg4 of human lactoferrin interact with sulphated molecules but not with the receptor present on Jurkat human lymphoblastic T-cells. *Biochem J* **327**: 841-846.
- Leslie AG (1999) Integration of macromolecular diffraction data. *Acta Cryst* **D55**: 1696-1702.
- Mann DM, Romm E and Migliorini M (1994) Delineation of the glycosaminoglycan-binding site in the human inflammatory response protein lactoferrin. *J Biol Chem* **269**: 23661-23667.
- McRee DE (1999) XtalView/Xfit - A versatile program for manipulating atomic coordinates and electron density. *J Struct Biol* **125**: 156-165.
- Metz-Boutigue M, Jolles J, Mazurier J, Schoentgen F, Legrand D, Spik G, Montreuil J and Jolles P (1984) Human lactoferrin: Amino acid sequence and structural comparisons with other transferrins. *Eur J Biochem* **145**: 659-676.
- Murshudov GN, Vagin AA and Dodson EJ (1997) Refinement of macromolecular structures by the maximum-likelihood method. *Acta Cryst* **D53**: 240-255.
- Nagasako Y, Saito H, Tamura Y, Shimamura S and Tomita M (1993) Iron-binding properties of bovine lactoferrin in iron-rich solution. *J Dairy Sci* **76**: 1876-1881.
- Nuijens JH, van Berkel PHC and Schanbacher FL (1996) Structure and biological actions of lactoferrin. *J Mammary Gland Biol Neoplasia* **1**: 285-295.
- Reiter B, Brock JH and Steel ED (1975) Inhibition of *Escherichia coli* by bovine colostrum and post-colostral milk II: The bacteriostatic effect of lactoferrin on a serum-susceptible and serum-resistant strain of *E. coli*. *Immunol* **28**: 83-95.
- Rey MW, Woloshuk SL, de Boer HA and Pieper FR (1990) Complete nucleotide sequence of human mammary gland lactoferrin. *Nucleic Acids Res* **18**: 5288.
- Sanchez L, Calvo M and Brock JH (1992) Biological role of lactoferrin. *Arch Dis Child* **67**: 657-661.
- Spik G, Strecker G, Fournet B, Bouquelet S, Montreuil J, Dorland L, Van Halbeek H and Vliegthart JFG (1982) Primary structure of the glycans from human lactotransferrin. *Eur J Biochem* **121**: 413-419.
- Sun X-L, Baker HM, Shewry SC, Jameson GB and Baker EN (1999) Structure of recombinant human lactoferrin expressed in *Aspergillus awamori*. *Acta Cryst* **D55**: 403-407.
- Vagin A and Teplyakov A (1997) MOLREP: An automated program for molecular replacement. *J Appl Cryst* **30**: 1022-1025.
- van Berkel PH, van Veen HA, Geerts ME, de Boer HA and Nuijens JH (1996) Heterogeneity in utilization of N-glycosylation sites Asn624 and Asn138 in human lactoferrin: A study with glycosylation-site mutants. *Biochem J* **319**: 117-122.
- van Berkel PHC, Geerts MEJ, van Veen HA, Kooiman PM, Pieper F, de Boer HA and Nuijens JH (1995) Glycosylated and unglycosylated human lactoferrins can both bind iron and have identical affinities towards human lysozyme and bacterial lipopolysaccharide, but differ in their susceptibility towards tryptic proteolysis. *Biochem J* **312**: 107-114.
- van Berkel PHC, Welling MM, Geerts M, van Veen HA, Ravensbergen B, Salaheddine M, Pauwels EKJ, Pieper F, Nuijens JH and Nibbering PH (2002) Large scale production of recombinant human lactoferrin in the milk of transgenic cows. *Nat Biotechnol* **20**: 484-487.
- van Veen HA, Geerts MEJ, van Berkel PHC and Nuijens JH (2004) The role of N-linked glycosylation in the protection of human and bovine lactoferrin against tryptic proteolysis. *Eur J Biochem* **271**: 678-684.
- Vriend G (1990) WHAT IF: A molecular modeling and drug design program. *J Mol Graph* **8**: 52-56.
- Ziere GJ, Bijsterbosch MK and van Berkel TJ (1993) Removal of 14 N-terminal amino acids of lactoferrin enhances its affinity for parenchymal liver cells and potentiates the inhibition of beta-very low density lipoprotein binding. *J Biol Chem* **268**: 27069-27075.
- Zucali JR, Broxmeyer HE, Levy D and Morse C (1989) Lactoferrin decreases monocyte-induced fibroblast production of myeloid colony-stimulating activity by suppressing monocyte release of interleukin-1. *Blood* **74**: 1531-1536.

Chapter 7

The role of N-linked glycosylation in the protection of human and bovine lactoferrin against tryptic proteolysis

Harrie A. van Veen, Marlieke E. J. Geerts, Patrick H. C. van Berkel* and Jan H. Nuijens

Pharming, Archimedesweg, Leiden, the Netherlands

Lactoferrin (LF) is an iron-binding glycoprotein of the innate host defence system. To elucidate the role of N-linked glycosylation in protection of LF against proteolysis, we compared the tryptic susceptibility of human LF (hLF) variants from human milk, expressed in human 293(S) cells or in the milk of transgenic mice and cows. The analysis revealed that recombinant hLF (rhLF) with mutations Ile130→Thr and Gly404→Cys was about twofold more susceptible than glycosylated and unglycosylated variants with the naturally occurring Ile130 and Gly404. Hence, N-linked glycosylation is not involved in protection of hLF against tryptic proteolysis. Apparently, the previously reported protection by N-linked glycosylation of hLF [van

Berkel, P.H.C., Geerts, M.E.J., van Veen, H.A., Kooiman, P.M., Pieper, F., de Boer, H.A. & Nuijens, J.H. (1995) *Biochem. J.* **312**, 107–114] is restricted to rhLF containing the Thr130 and Cys404. Comparison of the tryptic proteolysis of hLF and bovine LF (bLF) revealed that hLF is about 100-fold more resistant than bLF. Glycosylation variants A and B of bLF differed by about 10-fold in susceptibility to trypsin. This difference is due to glycosylation at Asn281 in bLF-A. Hence, glycosylation at Asn281 protects bLF against cleavage by trypsin at Lys282.

Keywords: lactoferrin; tryptic susceptibility; N-linked glycosylation; transgenic; gastrointestinal.

Lactoferrin (LF) is a metal-binding glycoprotein of M_r 77 000 that belongs to the transferrin family [1]. The molecule is found in secretions such as milk, tears and saliva, but also in the secondary granules of neutrophils (reviewed in [2]). LF is involved in nonspecific host defence against infection and severe inflammation, most notably at mucosal surfaces such as those of the gastrointestinal tract [2]. Antimicrobial activities of LF include bacteriostasis by the sequestration of free iron [3] and bactericidal activity by destabilization of the cell wall [4,5]. Anti-inflammatory actions of LF include inhibition of hydroxyl-radical formation [6], of complement activation [7] and of cytokine production [8] as well as binding and neutralization of lipopolysaccharide (LPS) [9,10].

LF consists of a single polypeptide chain that is folded in two highly homologous lobes, designated the N- and C-lobe, each of which can bind a single ferric ion

concomitantly with one bicarbonate anion [11]. The amino acid sequence of human LF (hLF) shows 69% homology with bovine LF (bLF) [12]. Three and five possible N-linked glycosylation sites are present in hLF [13] and bLF [12], respectively, and differential utilization of these sites results in distinct glycosylation variants. In hLF, N-linked glycosylation occurs at one (Asn479), two (Asn138 and 479) or three sites (Asn138, 479 and 624) in about 5%, 85% and 9% of the molecules, respectively [14]. In bLF, four sites (Asn233, 368, 476 and 545) are always utilized [15] while the fifth (Asn281), located in the N-lobe, is glycosylated in about 30% of the molecules in bovine colostrum, but only in about 15% in mature milk [16–18]. The significance of glycosylation for lactoferrin is not completely understood, although protection against proteases such as the pancreatic enzyme trypsin has been suggested [19,20].

The experiments described herein further elucidate the role of N-linked glycosylation in the protection of lactoferrin against tryptic proteolysis. It appeared that glycosylation at Asn281 protects bLF against trypsin. On the contrary, N-linked glycosylation is not involved in the protection of hLF, even though hLF is much more resistant against the protease than bLF.

Materials and methods

Reagents

Bovine pancreatic trypsin (type III-S) and soybean trypsin inhibitor (SBTI, type I-S) were purchased from Sigma Chemicals Co. (St. Louis, MO, USA). N-glycosidase F was obtained from Roche (Mannheim, Germany) and S Seph-areose fast flow was obtained from Amersham Biosciences (Uppsala, Sweden).

Correspondence to H. A. van Veen, Pharming, PO Box 451, 2300 AL Leiden, the Netherlands.

Fax: + 31 71 5247445, Tel.: + 31 71 5247190,

E-mail: h.veen@pharming.com

Abbreviations: bLF, bovine LF; LF, lactoferrin; hLF, human LF; natural hLF, hLF purified from human milk; iron-saturated hLF, natural hLF that has completely been saturated with iron *in vitro*; rhLF, recombinant hLF; rhLF^{gen}, rhLF derived from an hLF-genomic sequence; rhLF^{cDNA}, rhLF derived from the Rey hLF^{cDNA} sequence; rhLF-Gln138/479, rhLF^{cDNA} with Thr130→Ile, Cys404→Gly, Asn138→Gln and Asn479→Gln mutations.

*Current address: Genmab, Jenalaan 18d, 3584 CK Utrecht, the Netherlands.

(Received 27 August 2003, revised 22 October 2003,

accepted 12 December 2003)

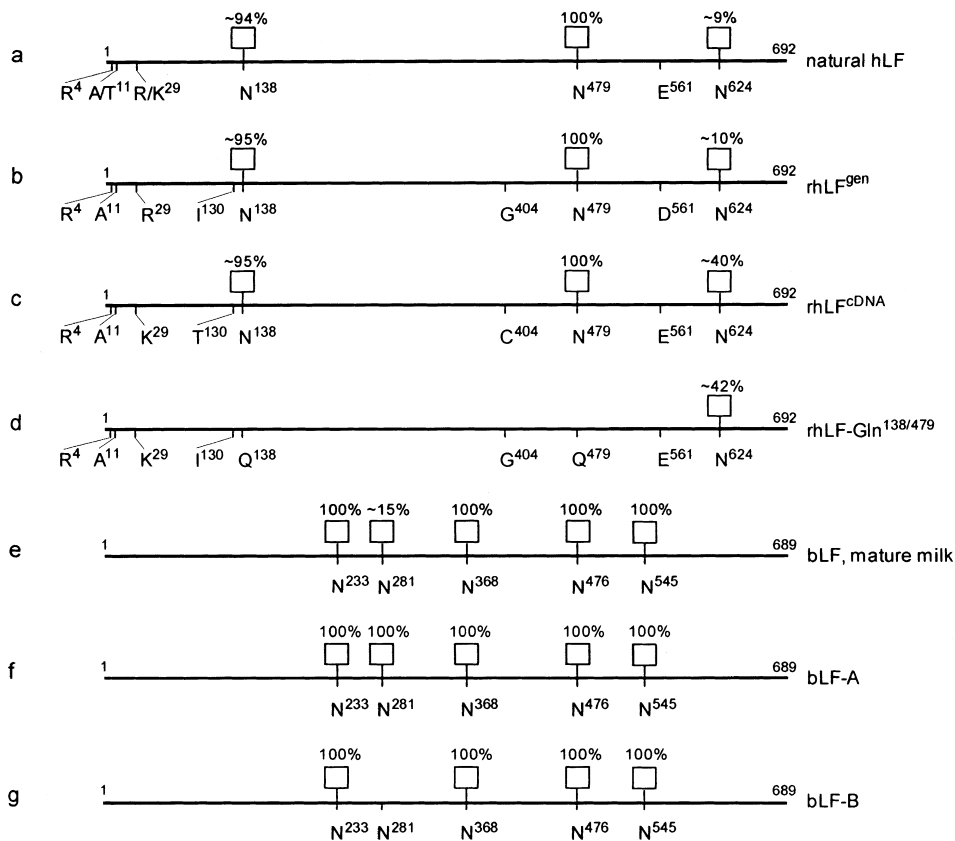

Fig. 1. Lactoferrin variants. The horizontal lines (a–g) represent the hLF and bLF variants used in this study. Short vertical lines together with the amino acids, presented by the standard one-letter code, mark the positions of polymorphic, mutation or N-glycosylation sites. Percentages (above boxes) indicate the proportion of molecules in which the glycosylation sites are actually used. Natural hLF (a) was isolated from a donor heterozygous at positions 11 and 29.

Human lactoferrin variants

Extensive analysis of hLF sequences revealed polymorphic sites in the coding sequence at amino acid position 4 (deletion of Arg), position 11 (Ala or Thr), position 29 (Arg or Lys) and position 561 (Asp or Glu) [18]. The Arg4 deletion in hLF in the Dutch population is rare, i.e. < 5%, while the other polymorphic variants are more evenly distributed. The donor who supplied milk to purify natural hLF for this study was heterozygous at position 11 and 29 (Fig. 1). Natural hLF was purified from human milk as described [19] and was saturated with iron at 3%; complete saturation of hLF with iron was performed as described [21].

Production, purification and characterization of recombinant hLF (rhLF) from milk of transgenic mice and cows was described previously [21,22]. Briefly, mammary gland-specific expression vectors based on the regulatory elements from the bovine α S₁ casein gene and either the hLF-cDNA coding sequence published by Rey *et al.* [13], designated rhLF^{cDNA}, or genomic hLF sequences, designated rhLF^{gen}, were introduced into the murine or bovine germ line. Purified rhLF from transgenic murine and bovine milk appeared to be saturated with iron for about 90% [21] and 8% [22], respectively. Enhanced N-linked glycosylation at Asn624 was observed in rhLF^{cDNA} but not in rhLF^{gen}. This

is probably caused by a unique cysteine at amino acid position 404 in the Rey cDNA sequence ([13], Fig. 1).

A stable human kidney 293(S) based cell-line expressing rhLF-Gln138/479, a glycosylation site mutant that was derived from rhLF^{cDNA}, in which the unique Thr130 and Cys404 were replaced by the naturally occurring Ile130 and Gly404 and Asn138 and Asn479 were mutated in Gln, has been described previously [14]. About 57% of purified rhLF-Gln138/479 is unglycosylated, whereas about 42% of the molecules are glycosylated at Asn624 [14]. In addition, rhLF-Gln138/479 appeared to be completely saturated with iron [14]. An overview of all LF variants is provided in Fig. 1.

Purification of bovine lactoferrin and separation in its variants

Bovine LF was purified from colostrum and mature milk of Frisian Holstein cows using S Sepharose essentially as described for hLF [19]. Colostrum derived bLF was diluted in 20 mM sodium phosphate, pH 7.5 and separated subsequently into bLF-A and bLF-B variants [16] by Mono S chromatography [18]. Mono S elution fractions containing the bLF variants were diluted again and subjected to rechromatography to obtain homogeneous bLF-A and bLF-B preparations.

Analytical Mono S chromatography

Analytical Mono S cation-exchange chromatography was performed as described [18]. Briefly, purified LF was diluted in 20 mM sodium phosphate, pH 7.5 (buffer A) and applied to a Mono S HR 5/5 column (Amersham Biosciences, Uppsala, Sweden) in buffer A. The column was washed subsequently and bound proteins were eluted with a linear salt gradient from 0 to 1 M NaCl in 30 mL of buffer A at a flow rate of 1.0 mL·min⁻¹. Eluted protein was detected by absorbance measurement at 280 nm.

Tryptic proteolysis of lactoferrin variants

Lactoferrin variants (0.4 mg·mL⁻¹, final concentration; except where indicated otherwise) were incubated with trypsin (0.4 mg·mL⁻¹, final concentration) at 37 °C in 50 mM Tris, pH 8.0, 0.14 M NaCl, 2 mM CaCl₂. At various timepoints the trypsin activity was stopped by the addition of a threefold excess of SBTI and the mixtures were subjected to nonreduced, boiled SDS/PAGE (12.5%) analysis [19]. Proteins were visualized by staining with Coomassie Brilliant Blue. Densitometry was performed using the Fluor-S Multi-Imager and QUANTITY ONE software from Biorad Laboratories, CA, USA. The tryptic susceptibility of distinct LF species was evaluated by focusing on the degradation of LF and/or by comparing the times required to degrade 50% of LF of *M_r* 80 000.

Results

Tryptic susceptibility of transgenic rhLF variants

Comparison of the tryptic susceptibility of rhLF^{CDNA} and rhLF^{gen} from transgenic mice with natural hLF and iron-saturated hLF revealed that the tryptic susceptibility of rhLF^{gen}, natural hLF and iron-saturated hLF was similar, whereas rhLF^{CDNA} was about twofold more susceptible (Fig. 2, lanes 5–12). The C-lobe derived tryptic fragments,

designated hC₁-tryp and hC₂-tryp, migrated as a doublet of protein bands in rhLF^{gen}, whereas single bands were observed in natural and iron-saturated hLF (Fig. 2, compare lanes 5 and 6 with 8). This difference results from glycosylation heterogeneity at glycosylation site Asn479 in rhLF^{gen} [14,21]. No predominant C-terminal tryptic bands were observed for rhLF^{CDNA} (Fig. 2, lanes 7 and 11), whereas similar amounts of clear-cut N-lobe fragments, designated hN₁-tryp, were observed for all iron-saturated LF species analysed.

Recombinant hLF^{gen} isolated from transgenic cow milk [22] displayed similar tryptic degradation kinetics compared to natural hLF (Fig. 3). The slightly faster migration of hC₁-tryp and hC₂-tryp of rhLF^{gen} from transgenic cattle compared to natural hLF (Fig. 3, lanes 3–6) resides in differential N-linked glycosylation of the two hLF variants [22]. Similar kinetics of tryptic degradation were also found for iron-saturated rhLF^{gen} from transgenic cattle and iron-saturated hLF (result not shown). The degradation kinetics of rhLF^{CDNA} from transgenic cow milk revealed this variant to be more susceptible towards trypsin than natural hLF and iron-saturated hLF, i.e. similar to rhLF^{CDNA} from transgenic mice (result not shown).

Taken together, these results suggest that rhLF^{CDNA} with the Gly404→Cys mutation shows increased susceptibility towards trypsin, when compared to rhLF^{gen} and natural hLF. Based on experiments with rhLF^{CDNA}, we concluded previously that N-linked glycosylation protects hLF against tryptic proteolysis [19]. As the tryptic susceptibility of rhLF^{CDNA} differs from natural hLF and rhLF^{gen} (Fig. 2), we decided to study the role of N-linked glycosylation in the protection of hLF in more detail, and also in LF variants with a glycine at position 404.

Susceptibility to tryptic proteolysis of unglycosylated rhLF

Similar kinetics of tryptic degradation were found for rhLF-Gln138/479 and iron-saturated hLF indicating that

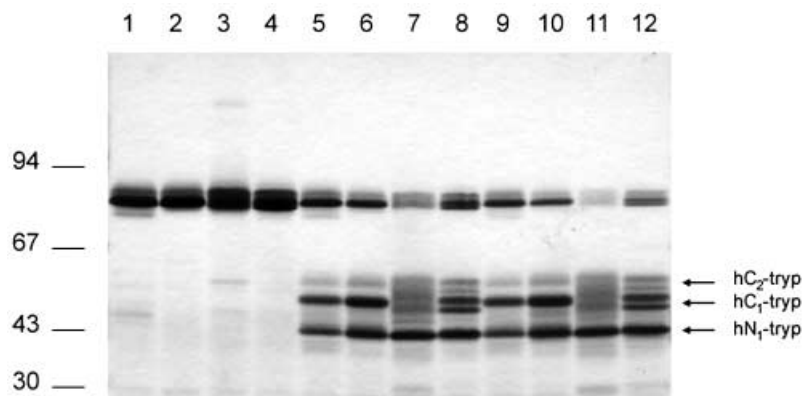

Fig. 2. Susceptibility to tryptic proteolysis of rhLF^{CDNA} and rhLF^{gen} from transgenic mice. Purified hLF variants (0.4 mg·mL⁻¹) were incubated with trypsin (0.4 mg·mL⁻¹) and subjected to nonreduced, boiled SDS/PAGE (12.5%) analysis as described in the Materials and methods. Natural hLF (lanes 1, 5 and 9), iron-saturated hLF (lanes 2, 6 and 10), rhLF^{CDNA} from transgenic mice (lanes 3, 7 and 11) and rhLF^{gen} from transgenic mice (lanes 4, 8 and 12); after 0, 120 and 240 min of digestion, respectively. Proteins were visualized by staining with Coomassie Brilliant Blue. Left-hand numbers (10⁻³ × *M_r*) indicate the migration of the protein standards. hC₂-tryp, hC₁-tryp and hN₁-tryp represent the tryptic C- and N-lobe fragments of hLF bearing either 2 or 1 N-linked glycans.

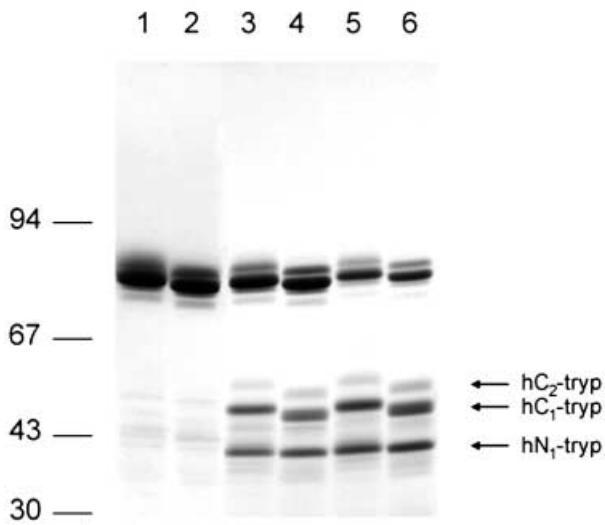

Fig. 3. Susceptibility to tryptic proteolysis of bovine transgenic rhLF^{gen}. SDS/PAGE (12.5%) analysis of tryptic digests obtained as described in the Materials and methods. Natural hLF (lanes 1, 3 and 5) and rhLF^{gen} from transgenic cow milk (lanes 2, 4 and 6); after 0, 60 and 240 min of digestion, respectively.

glycosylation at Asn138 and Asn479 is not involved in the protection of hLF against tryptic proteolysis (Fig. 4). The susceptibility to trypsin of unglycosylated- and Asn624-glycosylated rhLF in rhLF-Gln138/479 was very similar indicating that glycosylation at Asn624 is not essential to protect the molecule against trypsin (Fig. 4, lanes 1–3). These results contrast with the previous reported role of N-linked glycosylation in the protection of hLF against trypsin [19]. This observation appears to be valid only for rhLF^{CDNA} with the Gly404→Cys mutation.

Comparison of kinetics of tryptic degradation between hLF and bLF variants

When the tryptic susceptibility of hLF and bLF from mature milk was compared, hLF appeared to be about 100-fold less susceptible to trypsin than bLF (Fig. 5A). This difference confirms the observations of others [23]. It should be noted that this experiment provides no information on limited N-terminal degradation of hLF. We reported previously that the arginine-rich N-terminus of hLF is very susceptible towards tryptic proteolysis [24]. The bLF preparation used in this experiment consisted of two isoforms on Mono S chromatography [22] and SDS/PAGE (result not shown), which were previously identified as bLF-A and bLF-B [16]. Bovine LF-A and bLF-B differ in N-linked glycosylation at Asn281, which site is utilized in bLF-A, but not in bLF-B [17]. Analytical Mono S chromatography followed by peak surface integration indicated that bLF-A represents about 30% and 15% of total bLF in bovine colostrum and mature whey, respectively [18]. The two bLF variants were isolated as described in the Methods and analysed by Mono S chromatography which revealed symmetric peaks eluting at 0.76 and 0.80 M NaCl for bLF-A and bLF-B, respectively (Fig. 6A,B). The N-terminus of both variants was intact, indicating that the differential elution pattern on Mono S was not caused by limited proteolyses of the bLF N-terminus. SDS/PAGE analyses revealed homogeneous protein bands migrating at M_r 84 000 and 82 000 for bLF-A and bLF-B, respectively (Fig. 7, lanes 1–2). After deglycosylation with N-glycosidase F, both variants migrated with a M_r of 73 000 (Fig. 7, lanes 3–4), confirming that the difference in M_r between both bLF variants was caused by differences in N-linked glycosylation. Comparison of the degradation kinetics of bLF-A and bLF-B in a suboptimal buffer for trypsin activity, i.e. 0.9% NaCl, revealed that bLF-A was about 10-fold more resistant towards trypsin than bLF-B (Fig. 5B). This

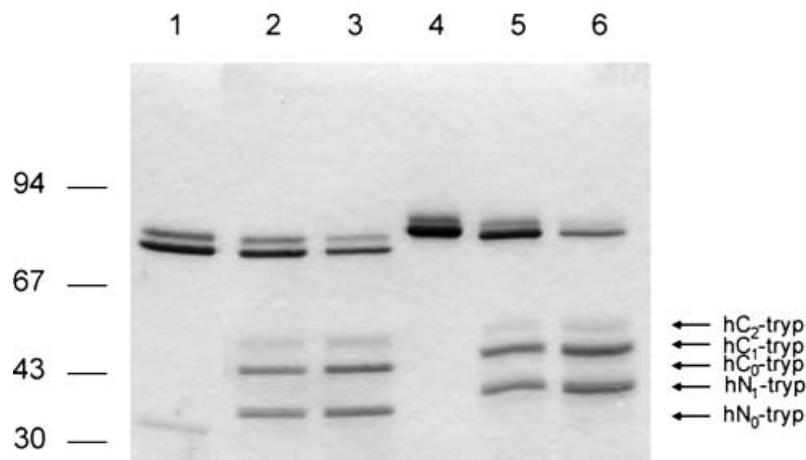

Fig. 4. Susceptibility to tryptic proteolysis of the rhLF-Gln138/479 glycosylation-site mutant. Lactoferrin ($80 \mu\text{g}\cdot\text{mL}^{-1}$) was incubated with trypsin ($80 \mu\text{g}\cdot\text{mL}^{-1}$) and subjected to SDS/PAGE (12.5%) analysis. rhLF-Gln138/479 (lanes 1–3) and iron-saturated hLF (lanes 4–6); after 0, 4 and 24 h of digestion, respectively. hC₂-tryp, hC₁-tryp, hC₀-tryp, hN₁-tryp and hN₀-tryp represent tryptic C- and N-lobe fragments of hLF bearing either 2, 1 or 0 N-linked glycans.

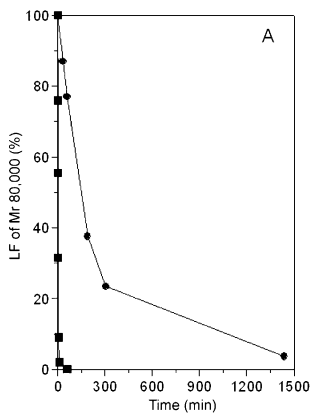

Fig. 5. Kinetics of trypsin degradation of hLF and bLF variants. (A) hLF (●) and bLF (■) from mature milk were incubated with trypsin in 50 mM Tris, pH 8.0, 0.14 M NaCl, 2 mM CaCl₂ and subjected to SDS/PAGE analysis as described in Materials and methods. Proteins were visualized by staining with Coomassie Brilliant Blue and residual LF migrating at $M_r \approx 80\,000$ was quantified using densitometry by reference to untreated LF, which was arbitrarily set at 100%. (B) Kinetics of tryptic proteolysis of bLF-A (●) and bLF-B (■) in 0.9% (w/v) NaCl.

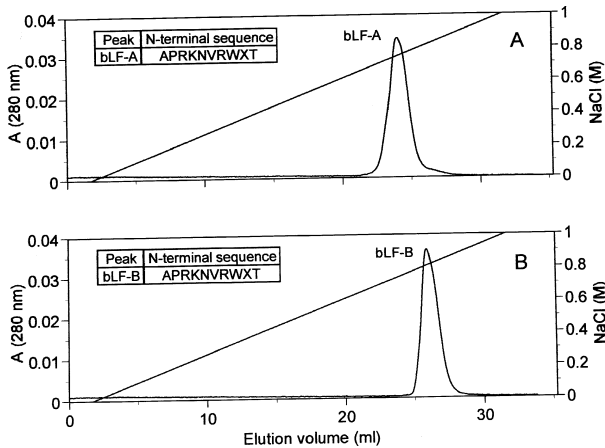

Fig. 6. Mono S chromatography and N-terminal protein sequencing of bLF variants. Forty micrograms of bovine colostrum purified bLF-A (A) and bLF-B (B) were subjected to analytical Mono S chromatography as described in the Materials and methods. The left and right abscissas indicate the absorption at 280 nm and NaCl concentration (M), respectively. The inserts provide the N-terminal protein sequencing results obtained as described [18].

suggests that glycosylation at Asn281 protects bLF against proteolysis at Lys282, the major tryptic cleavage site reported for bLF [25,26]. To further investigate this, the tryptic digests of bLF-A and bLF-B were compared on SDS/PAGE (Fig. 8), which revealed that the tryptic fragments of bLF-B (Fig. 8, lanes 4 and 6) were similar to the protein band pattern reported previously for trypsinized bLF [23,26]. Tryptic fragments, designated as bC₃-tryp, bC₃ and bN₁-tryp, with M_r values of 55 000, 46 000 and 36 000, respectively, were also present in the digest of bLF-A but it also contained an additional

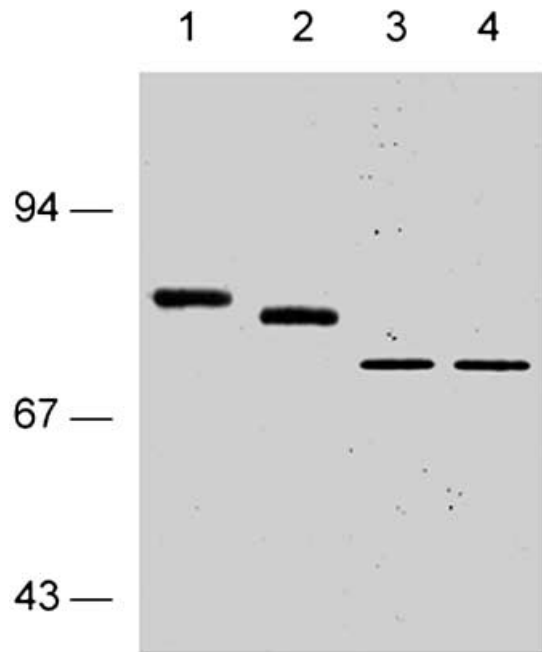

Fig. 7. SDS/PAGE analysis of deglycosylated bLF-A and bLF-B. Purified bLF-A and bLF-B were deglycosylated with N-glycosidase F [19] and subjected to nonreduced, boiled SDS/PAGE (7.5%) analysis. Lane 1, untreated bLF-A; lane 2, untreated bLF-B; lane 3, deglycosylated bLF-A; lane 4, deglycosylated bLF-B. Proteins, 300 ng per lane, were visualized by staining with silver.

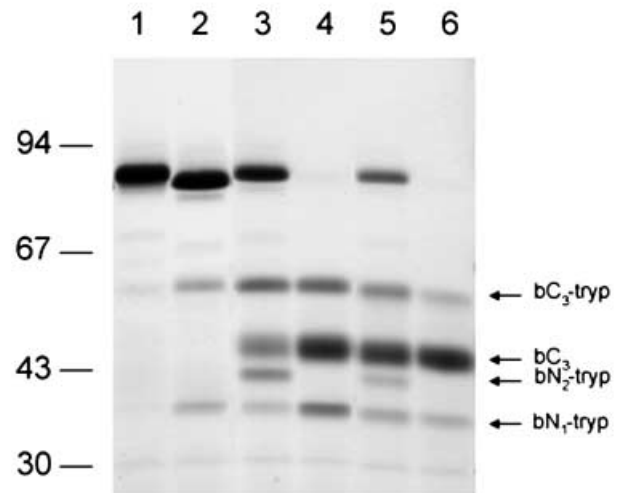

Fig. 8. SDS/PAGE analysis of tryptic digests of bLF-A and bLF-B. Tryptic digests of 10 μ g of bLF variants were applied to SDS/PAGE (12.5%), bLF-A (lanes 1, 3 and 5) and bLF-B (lanes 2, 4 and 6); after 0, 30 and 240 min of digestion, respectively. bC₃-tryp, bC₃, bN₂-tryp and bN₁-tryp indicates the tryptic C- and N-lobe fragments derived from bLF bearing either 3, 2 or 1 N-linked glycans. Left-hand numbers ($10^{-3} \times M_r$) indicate the migration of the protein standards.

protein band of M_r 41 000 (Fig. 8, lanes 3 and 5). We speculated that this fragment of bLF-A represents the N-terminal tryptic fragment with two N-linked glycans attached (confirmed by deglycosylation experiments;

results not shown) and it was therefore designated bN₂-tryp. Furthermore, the change in ratio between bN₂-tryp and bN₁-tryp bands in time (Fig. 8, compare lanes 3 to 5) suggests that bN₂-tryp is generated first and subsequently degraded into a protein band of M_r 36 000.

Taken together, these results suggest that the first cleavage of bLF by trypsin is after Lys282 and that glycosylation at Asn281 in bLF-A protects the molecule against proteolysis.

Discussion

Previously, we reported differences in tryptic susceptibility between N-linked glycosylated and unglycosylated rhLF [19]. The rhLF variants used in that study were derived from the Rey sequence [13], i.e. rhLF^{cDNA}, and comparison of glycosylated and unglycosylated rhLF^{cDNA} with natural hLF revealed that, although rhLF^{cDNA} was slightly more susceptible to tryptic proteolysis, the susceptibility was enhanced strongly in unglycosylated rhLF^{cDNA} [19]. Thus, we concluded that N-linked glycosylation protects hLF against tryptic proteolysis. However, here we show that, in case of naturally occurring hLF variants, N-linked glycosylation is not involved in protection of the molecule against trypsin.

First, we confirmed that rhLF^{cDNA} is more susceptible to trypsin than natural hLF, iron-saturated hLF or rhLF produced from a genomic sequence (rhLF^{gen}). The enhanced susceptibility, about twofold, of rhLF^{cDNA} is most pronounced in its C-terminus (Fig. 2). The rhLF^{cDNA} sequence contains two unique mutations, i.e. Ile130→Thr in the N-lobe and Gly404→Cys in the C-lobe, when compared to other published hLF sequences [18]. The Cys404 residue may cause alternative disulphide bonding in the C-lobe, which might explain an increased tryptic susceptibility. It is to be noted that Cys404 is located near Cys406, which may explain why a putative structural difference is rather subtle and did not appear from comparative studies of natural hLF and rhLF^{cDNA} by *in vitro* and *in vivo* antigenicity, iron-binding and release and binding to several ligands [21]. The only indication for a difference in conformation between rhLF^{cDNA} and natural hLF was the increased glycosylation at Asn624 in rhLF^{cDNA} ([21], Fig. 1) which is in line with the hypothesis that glycosylation at Asn624 in natural hLF is limited due to conformational and/or primary sequence constraints [14].

Secondly, the unglycosylated- and Asn624-glycosylated rhLF-Gln138/479 variants appeared equally resistant to trypsin when compared to iron-saturated hLF (Fig. 4). This result indicates that the absence of glycosylation in rhLF-Gln138/479, which has the naturally occurring Gly404, does not lead to increased tryptic susceptibility of the rhLF-Gln138/479 molecules.

Taken together, the results suggest that the Gly404→Cys mutation in rhLF^{cDNA} results in a slightly altered conformation, when compared to natural hLF, which accounts for the increased tryptic susceptibility. Evidently, the tryptic proteolysis assay is able to reveal subtle, previously unnoticed, differences between rhLF^{cDNA} and natural hLF.

Recombinant rhLF^{gen} from transgenic cows and natural hLF (Fig. 3) as well as their iron-saturated counterparts (result not shown) showed similar tryptic degradation

kinetics. Apparently, the polymorphic amino acid at position 561 i.e. Glu or Asp in natural hLF and rhLF^{gen}, respectively (Fig. 1), did not alter the tryptic degradation kinetics (Figs 2,3).

Similar to hLF, bLF occurs as a mixture of glycosylation variants, designated as bLF-A and bLF-B [16,17]. We obtained homogeneous preparations of bLF-A and bLF-B as shown by analytical Mono S chromatography (Fig. 6A,B) and SDS/PAGE (Fig. 7, lanes 1–2) and confirmed that glycosylation at Asn281 in the bLF N-lobe [17] explains for the larger molecular weight of bLF-A compared to bLF-B (Fig. 7). The major tryptic cleavage site reported for bLF is after Lys282 [25,26], which is located within the N-linked glycosylation sequon Asn281-Lys282-Ser283 [12]. N-linked glycosylation at Asn281 in bLF-A, but not in bLF-B, therefore most likely explains for the differential tryptic susceptibility (Figs 5B and 8).

The concentrations of bLF-A in colostrum (about 30% of total bLF) are higher than that in mature milk (about 15%). Recently, it was shown that bLF-A displays a higher bacteriostatic activity against *E. coli* than bLF-B [16]. As bLF-A is more resistant to proteolytic degradation than bLF-B, the first may also be superior in protection of the mammary gland and the intestinal tract of the newborn because it is more resistant to proteolytic degradation. However, even though bLF-A was about 10 times more resistant to trypsin than bLF-B, it was still much more sensitive to trypsin than hLF, i.e. hLF was found to be about 100-fold more resistant to trypsin than bLF (Fig. 5A). This is particularly interesting given the fact that Lys282 is the major trypsin cleavage site for both hLF and bLF [25]. Apparently, the conformation of bLF and hLF differs, with major cleavage sites being less accessible to trypsin in case of hLF, despite the 69% amino acid homology between the two proteins [12].

Experiments with pepsin also revealed differences between hLF and bLF i.e. hLF is less susceptible to digestion by pepsin than bLF (result not shown). The increased susceptibility of bLF, compared to hLF, to digestive proteases such as trypsin and pepsin are relevant when considering oral application of lactoferrin where the protein has to survive the harsh environment of the gastrointestinal tract. Thus, on the basis of this study, rhLF may be preferred over bLF in oral applications of lactoferrins in human healthcare.

Acknowledgements

We thank Marianne Kroos (Erasmus University, Rotterdam, the Netherlands) for performing the N-terminal protein sequencing.

References

1. Crichton, R.R. (1990) Proteins of iron storage and transport. *Adv. Prot. Chem.* **40**, 281–363.
2. Nuijens, J.H., van Berkel, P.H.C. & Schanbacher, F.L. (1996) Structure and biological actions of lactoferrin. *J. Mammary Gland Biol. Neoplasia* **1**, 285–295.
3. Reiter, B., Brock, J.H. & Steel, E.D. (1975) Inhibition of *Escherichia coli* by bovine colostrum and post-colostral milk. II. The

- bacteriostatic effect of lactoferrin on a serum-susceptible and serum-resistant strain of *E. coli*. *Immunology* **28**, 83–95.
4. Ellison, R.T. III, Giehl, T.J. & La, F.F. (1988) Damage of the outer membrane of enteric Gram-negative bacteria by lactoferrin and transferrin. *Infect. Immun.* **56**, 2774–2781.
 5. Ellison, R.T. III & Giehl, T.J. (1991) Killing of Gram-negative bacteria by lactoferrin and lysozyme. *J. Clin. Invest.* **88**, 1080–1091.
 6. Sanchez, L., Calvo, M. & Brock, J.H. (1992) Biological role of lactoferrin. *Arch. Dis. Child.* **67**, 657–661.
 7. Kijlstra, A. & Jeurissen, S.H.M. (1982) Modulation of the classical C3 convertase of complement by tear lactoferrin. *Immunology* **47**, 263–270.
 8. Zucali, J.R., Broxmeyer, H.E., Levy, D. & Morse, C. (1989) Lactoferrin decreases monocyte-induced fibroblast production of myeloid colony-stimulating activity by suppressing monocyte release of interleukin-1. *Blood* **74**, 1531–1536.
 9. Appelmek, B.J., An, Y.Q., Geerts, M., Thijs, B.G., de Boer, H.A., MacLaren, D.M., de Graaff, J. & Nuijens, J.H. (1994) Lactoferrin is a lipid A-binding protein. *Infect. Immun.* **62**, 2628–2632.
 10. Lee, W.J., Farmer, J.L., Hilty, M. & Kim, Y.B. (1998) The protective effects of lactoferrin feeding against endotoxin lethal shock in germfree piglets. *Infect. Immun.* **66**, 1421–1426.
 11. Anderson, B.F., Baker, H.M., Norris, G.E., Rice, D.W. & Baker, E.N. (1989) Structure of human lactoferrin: crystallographic structure analysis and refinement at 2.8 Å resolution. *J. Mol. Biol.* **209**, 711–734.
 12. Pierce, A., Colavizza, D., Benaissa, M., Maes, P., Tartar, A., Montreuil, J. & Spik, G. (1991) Molecular cloning and sequence analysis of bovine lactotransferrin. *Eur. J. Biochem.* **196**, 177–184.
 13. Rey, M.W., Woloshuk, S.L., de Boer, H.A. & Pieper, F.R. (1990) Complete nucleotide sequence of human mammary gland lactoferrin. *Nucleic Acids Res.* **18**, 5288.
 14. van Berkel, P.H., van Veen, H.A., Geerts, M.E., de Boer, H.A. & Nuijens, J.H. (1996) Heterogeneity in utilization of N-glycosylation sites Asn624 and Asn138 in human lactoferrin: a study with glycosylation-site mutants. *Biochem. J.* **319**, 117–122.
 15. Spik, G., Coddeville, B., Mazurier, J., Bourne, Y., Cambillaut, C. & Montreuil, J. (1994) Primary and three-dimensional structure of lactotransferrin (lactoferrin) glycans. *Adv. Exp. Med. Biol.* **357**, 21–32.
 16. Yoshida, S., Wei, Z., Shinmura, Y. & Fukunaga, N. (2000) Separation of lactoferrin-a and -b from bovine colostrum. *J. Dairy Sci.* **83**, 2211–2215.
 17. Wei, Z., Nishimura, T. & Yoshida, S. (2000) Presence of a glycan at a potential N-glycosylation site, Asn-281, of bovine lactoferrin. *J. Dairy Sci.* **83**, 683–689.
 18. van Veen, H.A., Geerts, M.E.J., van Berkel, P.H.C. & Nuijens, J.H. (2002) Analytical cation-exchange chromatography to assess the identity, purity and N-terminal integrity of human lactoferrin. *Anal. Biochem.* **309**, 60–66.
 19. van Berkel, P.H.C., Geerts, M.E.J., van Veen, H.A., Kooiman, P.M., Pieper, F., de Boer, H.A. & Nuijens, J.H. (1995) Glycosylated and unglycosylated human lactoferrins can both bind iron and have identical affinities towards human lysozyme and bacterial lipopolysaccharide, but differ in their susceptibility towards tryptic proteolysis. *Biochem. J.* **312**, 107–114.
 20. Wei, Z., Nishimura, T. & Yoshida, Y. (2001) Characterization of glycans in a lactoferrin isoform, lactoferrin-a. *J. Dairy Sci.* **84**, 2584–2590.
 21. Nuijens, J.H., van Berkel, P.H., Geerts, M.E., Hartevelt, P.P., de Boer, H.A., van Veen, H.A. & Pieper, F.R. (1997) Characterization of recombinant human lactoferrin secreted in milk of transgenic mice. *J. Biol. Chem.* **272**, 8802–8807.
 22. van Berkel, P.H.C., Welling, M.M., Geerts, M., van Veen, H.A., Ravensbergen, B., Salaheddine, M., Pauwels, E.K.J., Pieper, F., Nuijens, J.H. & Nibbering, P.H. (2002) Large scale production of recombinant human lactoferrin in the milk of transgenic cows. *Nat. Biotechnol.* **20**, 484–487.
 23. Brines, R.D. & Brock, J.H. (1983) The effect of trypsin and chymotrypsin on the in vitro antimicrobial and iron-binding properties of lactoferrin in human milk and bovine colostrum. Unusual resistance of human apolactoferrin to proteolytic digestion. *Biochim. Biophys. Acta* **759**, 229–235.
 24. Legrand, D., van Berkel, P.H.C., Salmon, V., van Veen, H.A., Slomianny, M.C., Nuijens, J.H. & Spik, G. (1997) The N-terminal Arg2, Arg3 and Arg4 of human lactoferrin interact with sulphated molecules but not with the receptor present on Jurkat human lymphoblastic T-cells. *Biochem. J.* **327**, 841–846.
 25. Legrand, D., Mazurier, J., Colavizza, D., Montreuil, J. & Spik, G. (1990) Properties of the iron-binding site of the N-terminal lobe of human and bovine lactotransferrins. Importance of the glycan moiety and of the non-covalent interactions between the N- and C-terminal lobes in the stability of the iron-binding site. *Biochem. J.* **266**, 575–581.
 26. Shimazaki, K., Tanaka, T., Kon, H., Oota, K., Kawaguchi, A., Maki, Y. & Sato, T. (1993) Separation and characterization of the C-terminal half molecule of bovine lactoferrin. *J. Dairy Sci.* **76**, 946–955.

Chapter 8

Characterization of Bovine Neutrophil Gelatinase-Associated Lipocalin

H. A. van Veen,¹ M. E. J. Geerts, R. A. A. Zoetemelk, J. H. Nuijens, and P. H. C. van Berkel²

Pharming, Archimedesweg 4, 2333 CN Leiden, The Netherlands

ABSTRACT

A protein of relative molecular mass of approximately 25,000 was purified from bovine colostrum by cation-exchange and size-exclusion chromatography. The N-terminus of the protein matched the sequence predicted by the National Center for Biotechnology Information for the bovine homolog of human neutrophil gelatinase-associated lipocalin, a glycoprotein of relative molecular mass 25,000 belonging to the family of lipocalins. The protein was further designated as bovine neutrophil gelatinase-associated lipocalin (bNGAL). Sodium dodecyl sulfate-PAGE of enzymically deglycosylated bNGAL indicated that the intact protein bears one N-linked glycan. Monosaccharide and mass spectrometric analyses of released N-linked carbohydrates revealed the presences of complex- and hybrid-type glycans, with galactose substituted with *N*-acetylgalactosamine. This substitution is typical for glycoproteins expressed in the bovine mammary gland. A specific ELISA revealed bNGAL concentrations in plasma and mature milk of about 0.05 and 1 $\mu\text{g}/\text{mL}$, respectively, whereas values as high as 51 $\mu\text{g}/\text{mL}$ were measured in colostrum. Thus, we have isolated and characterized a novel bovine (milk) protein that is a new member of the lipocalin family.

Key words: neutrophil gelatinase-associated lipocalin, lactoferrin, colostrum

INTRODUCTION

The lipocalins are a functionally diverse family of small extracellular proteins that belong to the superfamily of calycins (Flower, 1996). Despite their overall limited sequence homology, the lipocalins share a characteristic calyx- or cup-shaped structure that can bind to a variety of small hydrophobic ligands and macromolecules such as specific receptors (Flower, 1996). Members of the kernel subfamily of lipocalins include the species homologous proteins human neutrophil gela-

tinase-associated lipocalin (hNGAL, also named human neutrophil lipocalin), mouse 24p3/uterocalin (24p3), and rat α_2 -microglobulin-related protein (A2UMRP; Kjeldsen et al., 2000). These lipocalins are found in the specific granules of neutrophils and are secreted by the liver, kidney, bronchial, and gastrointestinal mucosa and by the mammary gland and uterus, most notably during involution (Kjeldsen et al., 2000).

A variety of functions have been attributed to hNGAL, 24p3, and A2UMRP. These include involvement in the transport of iron (Yang et al., 2002), fatty acids, and retinol (Chu et al., 1998); host defense against bacterial infection by sequestration of siderophore-bound iron (Goetz et al., 2002); and the induction of neutrophil apoptosis (Devireddy et al., 2001).

The AA sequence of hNGAL, a single-chain glycoprotein of relative molecular mass (M_r) 25,000, shows 62 and 63.5% identity with 24p3 and A2UMRP, respectively (Kjeldsen et al., 2000). X-ray crystallography (Goetz et al., 2000) and nuclear magnetic resonance spectroscopy of hNGAL (Coles et al., 1999) revealed the typical 8-stranded antiparallel β -barrel protein structure. However, the calyx appears to be unusually large and lined with positively charged AA.

Here we describe the purification and characterization of the bovine homolog of hNGAL, further referred to as bovine neutrophil gelatinase-associated lipocalin (bNGAL).

MATERIALS AND METHODS

Reagents

N-Glycosidase F and neuraminidase were obtained from Roche (Mannheim, Germany). Bovine lactoferrin (bLF) from mature milk was obtained from Sigma Chemical Co. (St. Louis, MO) or DMV (Veghel, The Netherlands) or was purified as described previously (van Veen et al., 2004). Bovine lactoferrin free of bNGAL was obtained by size-exclusion chromatography of purified bLF on a Superose 12 HR 10/30 column (Amersham Biosciences, Uppsala, Sweden). RapiGest was from Waters (Milford, MA), and the gel-filtration protein markers were from BioRad (Hercules, CA). Polyclonal rabbit anti-bNGAL antiserum was obtained after repeated intramuscular injection with purified

Received January 24, 2006.

Accepted March 31, 2006.

¹Corresponding author: h.veen@pharming.com

²Current address: Genmab BV, Yalelaan 60, 3508 AD Utrecht, The Netherlands.

bNGAL (see ensuing discussion) in Freund's adjuvant; specific antibody was purified by affinity purification on bNGAL-Sepharose and conjugated with horseradish peroxidase as described previously for human lactoferrin antibodies (van Berkel et al., 1995). Bovine leukocytes were isolated from EDTA-anticoagulated blood by successive centrifugations to remove plasma and red blood cell supernatants after lysis with ammonium chloride. The leukocyte pellet was suspended in 1% Triton X-100 and 10 mM EDTA and was frozen at -70°C until use.

Purification of bNGAL from Bovine Colostrum

Bovine NGAL and bLF were simultaneously extracted from colostrum of Friesian Holstein cows using S Sepharose (Amersham Biosciences). Bovine colostrum (3 L) to which sodium phosphate (20 mM final concentration) and NaCl (0.4 M) had been added was defatted by centrifugation ($1,600 \times g$, 15 min, 4°C) and subsequently incubated batchwise with S Sepharose (0.5 L). After incubation, the S Sepharose was washed with 20 mM sodium phosphate (pH 7.5) and 0.4 M NaCl and packed in a column (5×30 cm), and bound proteins were eluted with 20 mM sodium phosphate (pH 7.5) and 1 M NaCl at a flow rate of 10 mL/min. To separate bLF from bNGAL, the S Sepharose eluate was filtered over a Sephacryl S-200 HR column (2.6×70 cm; Amersham Biosciences) in 10 mM sodium phosphate (pH 7.4) and 1 M NaCl at a flow rate of 1.0 mL/min. The Sephacryl elution fractions containing bNGAL were diluted in 20 mM sodium phosphate (pH 7.5) and subjected to Mono S HR 5/5 chromatography (van Veen et al., 2002) to obtain a homogeneous bNGAL preparation. The recovery of bNGAL by using this procedure was about 40%.

Analytical Mono S Chromatography

Analytical cation-exchange chromatography using Mono S was performed as described previously (van Veen et al., 2002). Briefly, bovine colostrum to which NaCl was added (0.4 M final concentration) was centrifuged ($23,000 \times g$, 10°C , 150 min) to separate fat and casein fractions from the whey. The whey was filtered through a 0.22- μm filter and 500 μL was applied to a Mono S HR 5/5 column (Amersham Biosciences) equilibrated in 20 mM sodium phosphate (pH 7.5; buffer A) containing 0.4 M NaCl. The column was subsequently washed, and bound proteins were eluted with a linear salt gradient from 0.4 to 1 M NaCl in 18 mL of buffer A at a flow rate of 1.0 mL/min. Purified bNGAL (10 μg) was applied to the Mono S column in buffer A and eluted with a linear salt gradient from 0 to 1 M NaCl in 30 mL of buffer A at 1.0 mL/min.

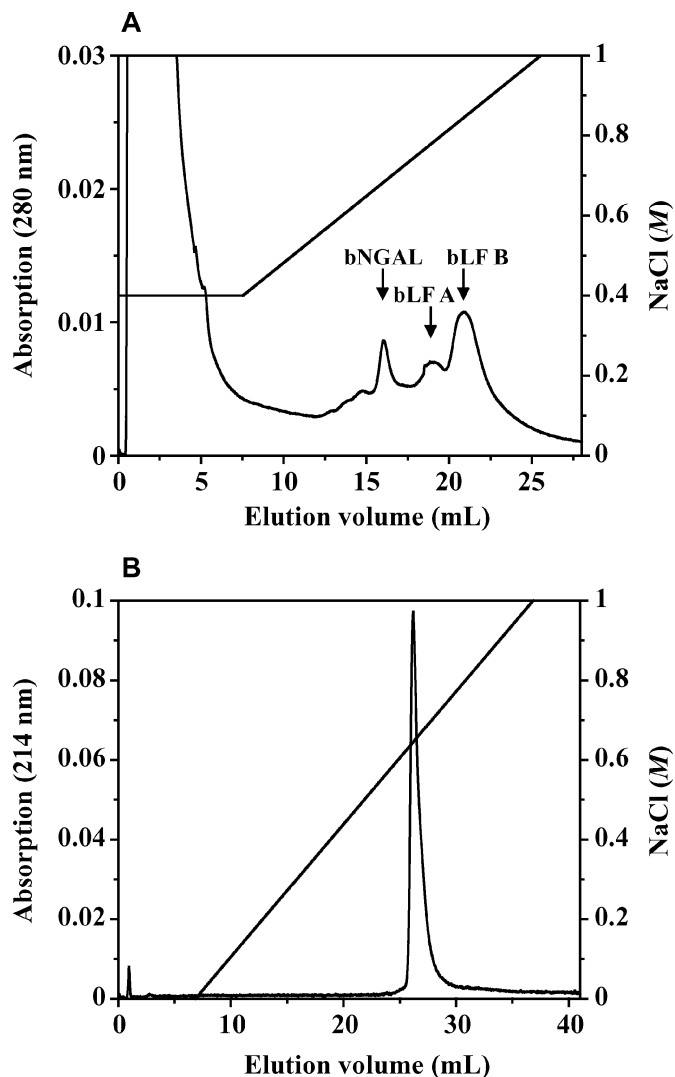

Figure 1. Analytical Mono S analysis of bovine whey and purified bovine neutrophil gelatinase-associated lipocalin (bNGAL). Whey obtained from bovine colostrum (panel A) or purified bNGAL (panel B) was analyzed on a Mono S column (Amersham Biosciences, Uppsala, Sweden). Left and right abscissas indicate absorption [at 280 nm (panel A) or 214 nm (panel B)] and NaCl concentration (M), respectively. Bovine lactoferrin (bLF) A and bLF B (panel A) represent the bLF A and B glycosylation variants (van Veen et al., 2004).

Mass Spectrometric and Monosaccharide Analysis of the bNGAL Glycans

Bovine neutrophil gelatinase-associated lipocalin (0.6 mg/mL) was incubated with 50 U/mL of N-glycosidase F and 0.5 U/mL neuraminidase in 20 mM sodium phosphate (pH 7.0) and 0.1% (wt/vol) RapiGest for 20 h at 37°C . Released desialylated N-glycans were analyzed by matrix-assisted laser desorption-ionization time-of-flight (MALDI-TOF) mass spectrometry in the reflector mode on an Applied Biosystems Voyager DE Pro mass spectrometer (Applied Biosystems, Foster City, CA).

The matrix was 2,5-dihydroxybenzoic acid (10 mg/mL) in 50:50:0.1% acetonitrile–water–trifluoroacetic acid. Spectra were obtained in the positive ion mode and glycans were detected as sodium adducts, $[M + Na]^+$. The monosaccharide analysis was performed as described previously (van Berkel et al., 2002).

Quantitative ELISA for bNGAL

Phosphate-buffered saline containing 1 μ g/mL of affinity-purified rabbit anti-bNGAL was incubated for 16 h at 20°C in microtiter plates (Polysorp; Nunc, Roskilde, Denmark). Plates were then washed with PBS and 0.02% (vol/vol) Tween-20 and incubated with serial dilutions in PTG buffer [PBS, 0.2% (wt/vol) porcine gelatin, and 0.02% (vol/vol) Tween-20] of purified bNGAL standard and test samples, which were pretreated by adding NaCl to 0.4 M. After 2 h, the plates were washed and PTG buffer containing 1% (vol/vol) rabbit serum and 0.3 μ g/mL of peroxidase-conjugated rabbit anti-bNGAL was added to each well. Plates were subsequently incubated for 1 h, washed, and tetramethylbenzidine substrate solution (Pierce, Rockford, IL) was added. Substrate conversion was stopped by the addition of 2 M H_2SO_4 , and the absorption at 450 nm was measured using a Power Wave microtiter plate reader (BioTek Instruments, Winooski, VT). All incubations were performed with 100- μ L volumes.

RESULTS

Purification of bNGAL from Bovine Colostrum

Analytical Mono S chromatography of bovine colostrum revealed a protein peak eluting at 0.67 M NaCl (Figure 1A, bNGAL), that is, before the lactoferrin glycosylation variants bLF A and bLF B (van Veen et al., 2004). On a preparative scale, the protein was purified using cation-exchange and size-exclusion chromatography as described in the Materials and Methods section. Analytical Mono S chromatography of the purified protein confirmed it to elute at 0.67 M NaCl and to be free of bLF (Figure 1B). Analytical size-exclusion chromatography of the purified protein on Superose 12 revealed a single peak eluting at 13.1 mL, which corresponds to a M_r of 25,000 by reference to the elution pattern of the protein standards (Figure 2).

N-Terminal Protein Sequencing of Purified bNGAL

N-Terminal protein sequencing revealed a single N-terminal sequence (Figure 3, bNGAL) indicating that the preparation was pure and devoid of proteolysis. The N-terminal sequence was determined for 41 AA. The observed N-terminus completely matched the sequence

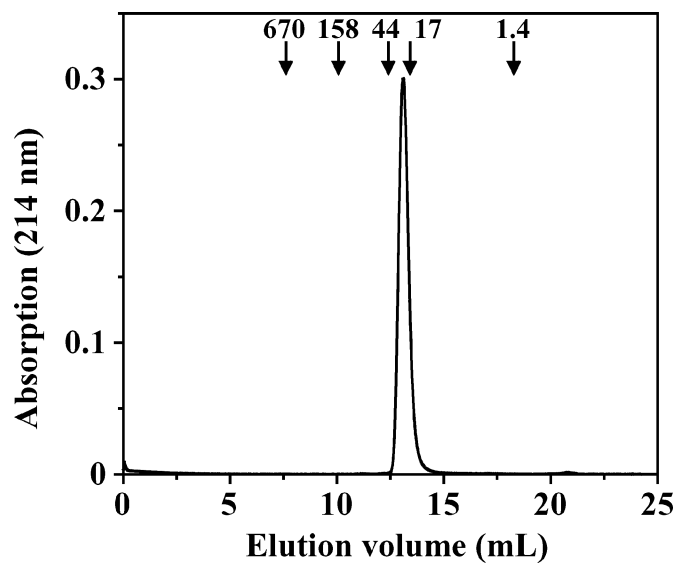

Figure 2. Superose 12 analysis of purified bovine neutrophil gelatinase-associated lipocalin (bNGAL). Bovine neutrophil gelatinase-associated lipocalin (10 μ g) was filtered over a Superose 12 HR 10/30 column (Amersham Biosciences, Uppsala, Sweden) in 20 mM sodium phosphate (pH 7.5) containing 0.75 M NaCl at a flow rate of 0.25 mL/min. The left abscissa indicates the absorption at 214 nm. The arrows indicate the elution of the protein standards ($10^{-3} \times M_r$).

predicted by the National Center for Biotechnology Information (annotation process of the bovine genome, XP_605012) for the bovine homolog of hNGAL. Identities of the observed N-termini with hNGAL, 24p3, and A2UMRP were 68, 54, and 49%, respectively. Taken together, the results indicated that the purified whey protein was a lipocalin and the bovine homolog of hNGAL, 24p3, and A2UMRP. The protein was further referred to as bNGAL.

SDS-PAGE Analysis of bNGAL

Nonreduced SDS-PAGE of purified bNGAL revealed 2 protein bands of M_r 43,000 and 25,000 (Figure 4, lane 1) that, upon reduction, shifted to M_r 45,000 and 26,000, respectively (Figure 4, lane 5). The M_r of 25,000 corresponded to the M_r of bNGAL found by size-exclusion chromatography, but a peak corresponding to a molecular mass of 43,000 was not observed on Superose 12 (Figure 2). Moreover, SDS-PAGE analysis of peak fractions taken from the Superose 12 chromatographic analysis revealed no separation between the 2 proteins (results not shown), indicating that the protein of M_r 43,000 likely represented a dimer formed upon denaturation of the bNGAL in SDS.

Sodium dodecyl sulfate-PAGE analysis of bNGAL treated with N-glycosidase F revealed protein bands of M_r 38,000 and 23,000 (Figure 4, lane 2), indicating that

Sequence	AA															
	1				5				10				15			
bNGAL	R	S	S	S	S	R	L	L	R	A	P	P	L	S	R	
NCBI: XP_605012	R	S	S	S	S	R	L	L	R	A	P	P	L	S	R	
hNGAL	Q	D	S	T	S	D	L	I	P	A	P	P	L	S	K	
24p3	Q	D	S	T	Q	N	L	I	P	A	P	S	L	L	T	
A2UMRP	Q	D	S	T	Q	N	L	I	P	A	P	P	L	I	S	
	16				20				25				30			
bNGAL	I	P	L	Q	P	N	F	Q	A	D	Q	F	Q	G	K	
NCBI: XP_605012	I	P	L	Q	P	N	F	Q	A	D	Q	F	Q	G	K	
hNGAL	V	P	L	Q	Q	N	F	Q	D	N	Q	F	Q	G	K	
24p3	V	P	L	Q	P	D	F	R	S	D	Q	F	R	G	R	
A2UMRP	V	P	L	Q	P	G	F	W	T	E	R	F	Q	G	R	
	31				35				40							
bNGAL	W	Y	T	V	G	V	A	G	N	A	I					
NCBI: XP_605012	W	Y	T	V	G	V	A	G	N	A	I					
hNGAL	W	Y	V	V	G	L	A	G	N	A	I					
24p3	W	Y	V	V	G	L	A	G	N	A	V					
A2UMRP	W	F	V	V	G	L	A	A	N	A	V					

Figure 3. N-Terminal protein sequencing of bovine neutrophil gelatinase-associated lipocalin (bNGAL). N-Terminal protein sequencing of bNGAL (20 μ g) was performed by the automatic Edman degradation procedure using an Applied Biosystems gas-phase sequencer, model 473A (Applied Biosystems, Foster City, CA). The sequencing result of bNGAL, presented by the standard one-letter code for AA, is aligned to the predicted sequence of bNGAL (National Center for Biotechnology Information: XP_605012) and published sequences of human neutrophil gelatinase-associated lipocalin (hNGAL), mouse 24p3/uterocalin (24p3), and rat α_2 -microglobulin-related protein (A2UMRP; Kjeldsen et al., 2000). The shaded box represents motif 1, a highly conserved sequence among lipocalins (Flower et al., 1991).

bNGAL was N-linked glycosylated. Based on the average M_r of 2,200 for a complex glycan (Spik et al., 1988), the difference in M_r of 2,000 observed on SDS-PAGE before and after deglycosylation suggests that monomeric bNGAL (M_r 25,000) bears one N-linked glycan.

Glycan Structures Present on bNGAL

Monosaccharide analysis of bNGAL showed the presence of mannose, *N*-acetylgalactosamine, *N*-acetylglucosamine, and *N*-acetylneuraminic acid (Table 1). Fucose and galactose were hardly detected, which suggested that, in the event of N-linked glycosylation of bNGAL, galactose was substituted with *N*-acetylgalactosamine. This has previously been observed for other N-linked glycoproteins produced in bovine milk and has been ascribed to the presence of an *N*-acetylgalactosaminyl transferase in mammary gland epithelium (Van den Nieuwenhof et al., 1999). The MALDI-TOF analysis of desialylated bNGAL glycans showed 7 significant peaks (Figure 5, peaks A–G). The proposed glycan compositions and structures, deduced from the mass-to-charge (m/z) values of 6 of these peaks, are shown in

Table 2 and Figure 6, respectively. The observed m/z value of each proposed structure differs maximally by 0.42 Da from the theoretical value of the glycan (Table 2). The majority of the masses could be assigned to complex- or hybrid-type glycans with only *N*-acetylgalactosamine in their antennae (Table 2, Figure 6). Glycan structures B and G, which are minor peaks in the MALDI-TOF spectrum (Figure 5), likely represent fucosylated variants of structures A and E, respectively. Major peaks C and D may, in theory, also represent complex-type glycans bearing galactose in their antennae. However, this is considered less likely given the absence of galactose in the monosaccharide analysis, although it cannot be excluded that minor amounts of glycans bearing galactose are present. Structure F could not be assigned on the basis of available data, but might represent a sulfated variant of glycan E or a hybrid-type glycan D with an additional mannose. High-performance anion-exchange chromatography—pulse amperometric detection analysis (Barroso et al., 2002) of the N-linked glycans of bNGAL before and after desialylation showed that the majority of the glycan structures contained one *N*-acetylneuraminic acid (results not shown).

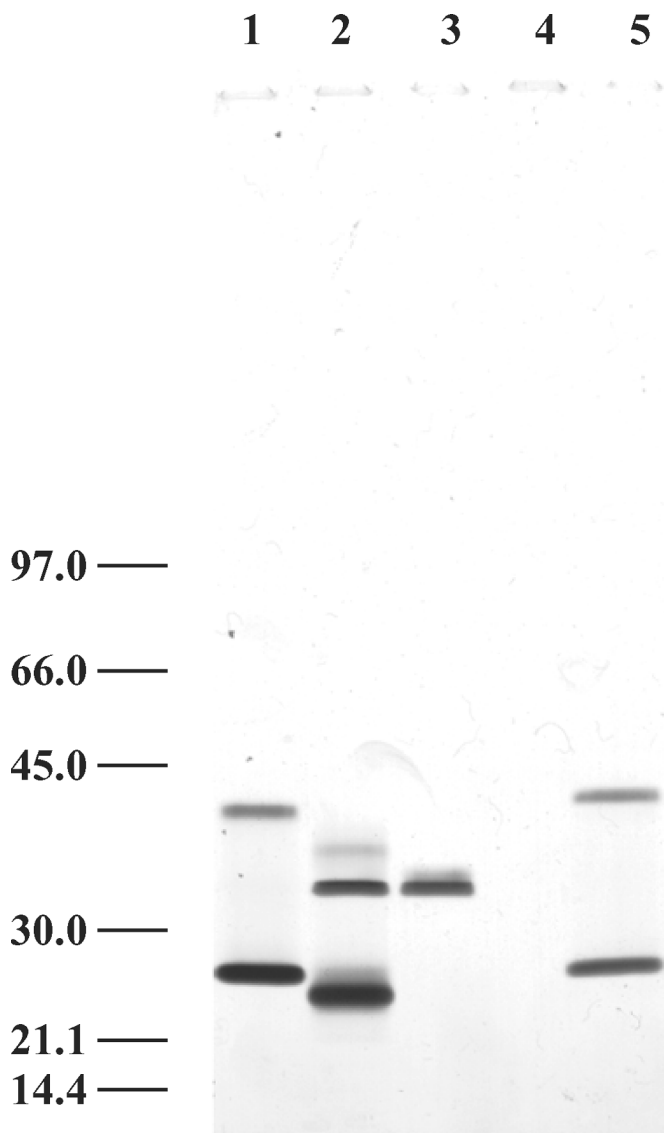

Figure 4. Sodium dodecyl sulfate-PAGE analysis of bovine neutrophil gelatinase-associated lipocalin (bNGAL). Nonreduced (lanes 1–4) and reduced (lane 5) SDS-PAGE (8–16%) analysis of bNGAL was performed as described (van Veen et al., 2002). Lanes 1 and 5: bNGAL (400 ng); lane 2: bNGAL treated with N-glycosidase F; lane 3: N-glycosidase F; lane 4: SDS sample buffer. Proteins were visualized with silver. The migration of the protein markers is indicated on the left ($10^{-3} \times M_r$).

Identification and Concentration of bNGAL in Bovine Samples

A bNGAL-specific ELISA was developed using affinity-purified rabbit anti-bNGAL antibodies. The detection limit of the ELISA was 0.5 ng/mL of bNGAL and the intra and interassay coefficients of variations were 6 and 8%, respectively. Furthermore, the ELISA did not detect bLF (Figure 7) and showed complete recovery

Table 1. Monosaccharide composition of bovine neutrophil gelatinase-associated lipocalin (bNGAL)

Monosaccharide	bNGAL
Fucose	<0.1
Mannose	3.0 ¹
Galactose	<0.1
Glucose	<0.1
N-Acetylgalactosamine	1.0
N-Acetylglucosamine	3.1
N-Acetylneuraminic acid	0.8

¹Results are expressed relative to the amount of mannose, which was arbitrarily set at 3.0.

of bNGAL when added to the biological matrices tested (results not shown).

Parallel curves were obtained for colostrum-purified bNGAL and a lysate from leukocytes (Figure 7), indicating the presence of bNGAL in leukocytes. The concentration of bNGAL in bovine plasma, as determined by reference to a purified bNGAL standard, was approximately 0.05 $\mu\text{g/mL}$. Parallel curves between purified bNGAL and bNGAL in milk were obtained after preincubation of the milk in 0.4 M NaCl. Apparently, the salt was necessary to disrupt electrostatic interactions between bNGAL and the casein micelles, which is similar to previous observations for the detection of human lactoferrin in murine milk (Nuijens et al., 1997). The bNGAL concentration in mature milk was about 1 $\mu\text{g/mL}$, whereas levels as high as 51 $\mu\text{g/mL}$ were measured in colostrum samples. Analysis of various bLF preparations in the ELISA revealed bNGAL levels of 0.7% (wt/wt) in 2 preparations purified as described previously (van Veen et al., 2004). In commercial bLF, bNGAL levels were measured to 2.2% (wt/wt). Taking into account the 3-fold difference in M_r between bNGAL (M_r 25,000) and bLF (M_r 77,000; Nuijens et al., 1996), the bNGAL contamination in bLF preparations can be substantial (i.e., about 7% on a molar ratio).

DISCUSSION

This study details the purification and characterization of the bovine homolog of hNGAL, mouse 24p3, and rat A2UMRP. The homology of the bovine protein, designated bNGAL, was based on N-terminal sequence identity with the predicted sequence and said lipocalins (Figure 3).

Bovine neutrophil gelatinase-associated lipocalin was extracted from colostrum using cation-exchange chromatography at 0.4 M NaCl (Figure 1A), which indicates that bNGAL is strongly positively charged. Further purification to homogeneity (Figures 1B, 2, and 4) involved chromatography on Sephacryl S-200 and Mono S.

Table 2. Proposed N-linked glycan compositions of desialylated bovine neutrophil gelatinase-associated lipocalin (bNGAL)

Peak	Observed ion, ¹ <i>m/z</i>	Proposed glycan composition	Theoretical ion, <i>m/z</i>
A	1,339.79	(Hex) ₃ (HexNAc) ₄ ²	1,339.48
B	1,485.87	(Hex) ₃ (HexNAc) ₄ (Deoxyhex) ₁	1,485.53
C	1,501.87	(Hex) ₄ (HexNAc) ₄	1,501.53
D	1,663.94	(Hex) ₅ (HexNAc) ₄	1,663.58
E	1,745.99	(Hex) ₃ (HexNAc) ₆	1,745.64
F	1,825.99	No assignment possible	—
G	1,892.11	(Hex) ₃ (HexNAc) ₆ (Deoxyhex) ₁	1,891.69

¹Mass-to-charge values ($[M + Na]^+$) of desialylated released glycans of bNGAL (Figure 5).

²Hex = hexose; HexNAc = *N*-acetylhexosamine; Deoxyhex = deoxyhexose.

Analytical gel-filtration chromatography of bNGAL revealed an M_r of approximately 25,000 (Figure 2). Sodium dodecyl sulfate-PAGE analysis of untreated and deglycosylated bNGAL confirmed the M_r of 25,000 and showed that bNGAL bore one N-linked glycan (Figure 4). These results are highly similar to the M_r and N-linked glycosylation reported for hNGAL (Kjeldsen et al., 1993).

On SDS-PAGE, a minor portion of purified bNGAL migrated, with an M_r of 43,000. This band did not disappear upon reduction, which excludes the possibility that dimers were formed through disulfide bonding upon heating and denaturation and that bNGAL, like 24p3 and A2UMRP, does not have a free sulfhydryl group

as in hNGAL (Kjeldsen et al., 2000). Sodium dodecyl sulfate-PAGE analysis of Superose 12 fractions showed no separation of the 2 proteins by size-exclusion chromatography. Furthermore, SDS-PAGE experiments have indicated that the putative bNGAL dimer-to-monomer ratio increases with higher ionic strength prior to dilution in SDS sample buffer (result not shown). Taken together, the protein of M_r 43,000 most likely occurs as a laboratory artifact; however, it cannot be excluded that dimerization of bNGAL occurs in vivo, because this is a characteristic trait among lipocalins (Kjeldsen et al., 2000).

A bNGAL-specific ELISA detected the molecule in lysed leukocytes (Figure 7). The plasma concentration of bNGAL, likely released from the specific granules of activated neutrophils, is very similar to that of hNGAL in the plasma of healthy volunteers, that is, approximately 0.05 $\mu\text{g}/\text{mL}$ (Xu et al., 1994). Very similar to the changes in bLF concentration during lactation (Schanbacher et al., 1993), the bNGAL concentration in colostrum is much higher than in mature milk. Given the similarity in changes of expression with lactation phases, even higher bNGAL concentrations may be found at involution of the bovine mammary gland, which has been reported for bLF (Schanbacher et al., 1993), 24p3 (Ryon et al., 2002), and A2UMRP (Stoesz and Gould, 1995).

With the ELISA, a significant contamination (as high as 7% on a molar ratio) of bLF preparations with bNGAL could be detected. Although the exact physiological role of bNGAL is unknown, the molecule might have antibacterial activities similar to those ascribed to hNGAL (Goetz et al., 2002). Consequently, contamination of (commercially obtained) bLF preparations with bNGAL may have complicated experiments on the antibiotic properties of bLF. Therefore, we recommend removing all bNGAL from bLF prior to in vitro or in vivo studies. Separation of bLF from bNGAL can be achieved by cation-exchange, gel-filtration, or lectin chromatography on concanavalin A (results not shown).

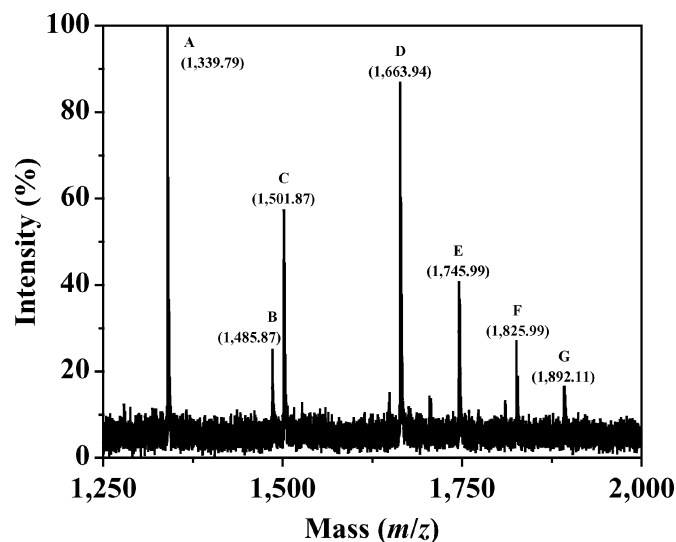

Figure 5. Matrix-assisted laser desorption–ionization time-of-flight (MALDI-TOF) analysis of bovine neutrophil gelatinase-associated lipocalin (bNGAL) glycans. Bovine neutrophil gelatinase-associated lipocalin released and desialylated N-linked glycans were subjected to MALDI-TOF analysis as described in the Materials and Methods section. The results are provided by the relative intensity (%) as a function of the mass-to-charge ratio (m/z). Values in parentheses indicate the m/z value of the associated peak.

Peak	Proposed glycan structures
A	
B	Fucosylated variants of structures A
C	
D	
E	
F	No assignment possible
G	Fucosylated variants of structure E

Figure 6. Proposed N-linked glycan structures of desialylated bovine neutrophil gelatinase-associated lipocalin (bNGAL). The proposed N-linked glycan structures were deduced from the glycan compositions of the indicated peaks (Table 2). N-Acetylglucosamine: □; mannose: ○; N-acetylgalactosamine: ■.

The separation on concanavalin A underlines the differences in the N-linked glycan structures present on bNGAL and bLF. Bovine neutrophil gelatinase-associated lipocalin harbors mainly complex- and hybrid-type glycans (Table 2, Figure 6), whereas bLF also bears high-mannose type glycans (Coddeville et al., 1992), which have a higher affinity for concanavalin A.

Recently, the expression of mouse 24p3 by the mammary gland epithelium was reported (Ryon et al., 2002).

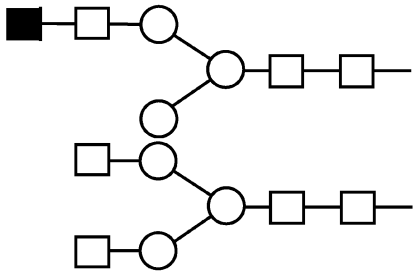
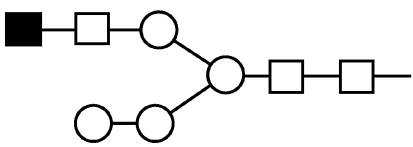
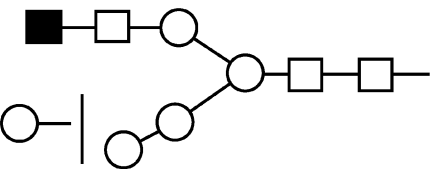
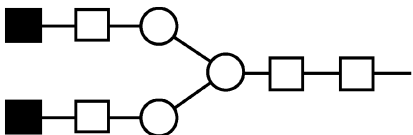
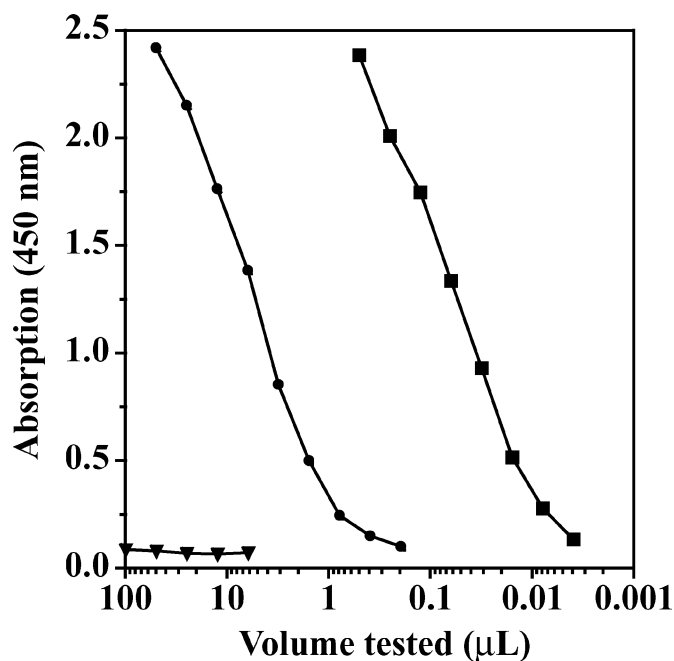

Figure 7. Dose-response curves of purified bovine neutrophil gelatinase-associated lipocalin (bNGAL) and a lysate from leukocytes in the bNGAL ELISA. Serial dilutions of purified bNGAL (●, 50 ng/mL), bovine lactoferrin (▼, 2 µg/mL), and a lysate from bovine leukocytes (■) were incubated with affinity-purified rabbit anti-bNGAL coated on microtiter plates as described in the Materials and Methods section. Bound bNGAL was detected by subsequent incubation with peroxidase-conjugated anti-bNGAL. The A_{450} values, measured as described, are plotted as a function of the experimental volume (microliters) tested.

Bovine neutrophil gelatinase-associated lipocalin might be released in milk from activated neutrophils or mammary gland epithelial cells or both. The analysis of purified colostrum bNGAL suggests that it is produced by the epithelium because substitution of galactoses with N-acetylgalactosamine is a typical feature of glycoproteins produced in the bovine mammary gland (Van den Nieuwenhof et al., 1999). In conclusion, we have isolated, identified, and characterized a novel bovine (milk) protein that is a new member of the lipocalin family and the homolog of hNGAL, 24p3, and A2UMRP.

ACKNOWLEDGMENTS

We thank J. Kamerling and G. Gerwig (University of Utrecht, Utrecht, The Netherlands) for the monosaccharide composition analysis and M. Kroos (Erasmus University, Rotterdam, The Netherlands) for performing the N-terminal sequencing. F. Lagerwerf and R. Dijkstra (Crucell, Leiden, The Netherlands) are acknowledged for performing the mass spectrometric analysis.

REFERENCES

- Barroso, B., R. Dijkstra, M. Geerts, F. Lagerwerf, P. van Veelen, and A. de Ru. 2002. On-line high-performance liquid chromatography/mass spectrometric characterization of native oligosaccharides from glycopeptides. *Rapid Commun. Mass Spectrom.* 16:1320–1329.
- Chu, S. T., H. J. Lin, H. L. Huang, and Y. H. Chen. 1998. The hydrophobic pocket of 24p3 protein from mouse uterine luminal fluid: Fatty acid and retinol binding activity and predicted structural similarity to lipocalins. *J. Pept. Res.* 52:390–397.
- Coddeville, B., G. Strecker, J. M. Wieruszski, J. F. G. Vliegenthart, H. van Halbeek, J. Peter-Katalinic, H. Egge, and G. Spik. 1992. Heterogeneity of bovine lactotransferrin glycans. *Carbohydr. Res.* 236:145–164.
- Coles, M., T. Diercks, B. Muehlenweg, S. Bartsch, V. Zolzer, H. Tschesche, and H. Kessler. 1999. The solution structure and dynamics of human neutrophil gelatinase-associated lipocalin. *J. Mol. Biol.* 289:139–157.
- Devireddy, L. R., J. G. Teodoro, F. A. Richard, and M. R. Green. 2001. Induction of apoptosis by a secreted lipocalin that is transcriptionally regulated by IL-3 deprivation. *Science* 293:829–834.
- Flower, D. R. 1996. The lipocalin protein family: Structure and function. *Biochem. J.* 318:1–14.
- Flower, D. R., C. North, and T. K. Attwood. 1991. Mouse oncogene protein 24p3 is a member of the lipocalin protein family. *Biochem. Biophys. Res. Commun.* 180:69–74.
- Goetz, D. H., M. A. Holmes, N. Borregaard, M. E. Bluhm, K. N. Raymond, and R. K. Strong. 2002. The neutrophil lipocalin NGAL is a bacteriostatic agent that interferes with siderophore-mediated iron acquisition. *Mol. Cell* 10:1033–1043.
- Goetz, D. H., S. T. Willie, R. S. Armen, T. Bratt, N. Borregaard, and R. K. Strong. 2000. Ligand preference inferred from the structure of neutrophil gelatinase associated lipocalin. *Biochemistry* 39:1935–1941.
- Kjeldsen, L., J. B. Cowland, and N. Borregaard. 2000. Human neutrophil gelatinase-associated lipocalin and homologous proteins in rat and mouse. *Biochim. Biophys. Acta* 1482:272–283.
- Kjeldsen, L., A. H. Johnsen, H. Sengelov, and N. Borregaard. 1993. Isolation and primary structure of NGAL, a novel protein associated with human neutrophil gelatinase. *J. Biol. Chem.* 268:10425–10432.
- Nuijens, J. H., P. H. van Berkel, M. E. Geerts, P. P. Hartevelt, H. A. de Boer, H. A. van Veen, and F. R. Pieper. 1997. Characterization of recombinant human lactoferrin secreted in milk of transgenic mice. *J. Biol. Chem.* 272:8802–8807.
- Nuijens, J. H., P. H. C. van Berkel, and F. L. Schanbacher. 1996. Structure and biological actions of lactoferrin. *J. Mammary Gland Biol. Neoplasia* 1:285–295.
- Ryon, J., L. Bendickson, and M. Nilsen-Hamilton. 2002. High expression in involuting reproductive tissues of uterocalin/24p3, a lipocalin and acute phase protein. *Biochem. J.* 367:271–277.
- Schanbacher, F. L., R. E. Goodman, and R. S. Talhouk. 1993. Bovine mammary lactoferrin: Implications from messenger ribonucleic acid (mRNA) sequence and regulation contrary to other milk proteins. *J. Dairy Sci.* 76:3812–3831.
- Spik, G., B. Coddeville, and J. Montreuil. 1988. Comparative study of the primary structures of sero-, lacto- and ovotransferrin glycans from different species. *Biochimie* 70:1459–1469.
- Stoesz, S. P., and M. N. Gould. 1995. Overexpression of neu-related lipocalin (NRL) in neu-initiated but not ras- or chemically initiated rat mammary carcinomas. *Oncogene* 11:2233–2241.
- van Berkel, P. H. C., M. E. J. Geerts, H. A. van Veen, P. M. Kooiman, F. Pieper, H. A. de Boer, and J. H. Nuijens. 1995. Glycosylated and unglycosylated human lactoferrins can both bind iron and have identical affinities towards human lysozyme and bacterial lipopolysaccharide, but differ in their susceptibility towards tryptic proteolysis. *Biochem. J.* 312:107–114.
- van Berkel, P. H. C., M. M. Welling, M. Geerts, H. A. van Veen, B. Ravensbergen, M. Salaheddine, E. K. J. Pauwels, F. Pieper, J. H. Nuijens, and P. H. Nibbering. 2002. Large scale production of recombinant human lactoferrin in the milk of transgenic cows. *Nat. Biotechnol.* 20:484–487.
- Van den Nieuwenhof, I. M., W. E. Schiphorst, I. Van Die, and D. H. Van den Eijnden. 1999. Bovine mammary gland UDP-GalNAc:GlcNAc β -R β 1 \rightarrow 4-N-acetylgalactosaminyltransferase is glycoprotein hormone nonspecific and shows interaction with α -lactalbumin. *Glycobiology* 9:115–123.
- van Veen, H. A., M. E. J. Geerts, P. H. C. van Berkel, and J. H. Nuijens. 2002. Analytical cation-exchange chromatography to assess the identity, purity and N-terminal integrity of human lactoferrin. *Anal. Biochem.* 309:60–66.
- van Veen, H. A., M. E. J. Geerts, P. H. C. van Berkel, and J. H. Nuijens. 2004. The role of N-linked glycosylation in the protection of human and bovine lactoferrin against tryptic proteolysis. *Eur. J. Biochem.* 271:678–684.
- Xu, S. Y., C. G. B. Petersson, M. Carlson, and P. Venge. 1994. The development of an assay for human neutrophil lipocalin (HNL)—To be used as a specific marker of neutrophil activity in vivo and vitro. *J. Immunol. Meth.* 171:245–252.
- Yang, J., D. Goetz, J.-Y. Li, W. Wang, K. Mori, D. Setlik, T. Du, H. Erdjument-Bromage, P. Tempst, R. Strong, and J. Barasch. 2002. An iron delivery pathway mediated by a lipocalin. *Mol. Cell* 10:1045–1056.

Chapter 9

Sub-chronic (13-week) oral toxicity study in rats with recombinant human lactoferrin produced in the milk of transgenic cows

M.J. Appel^{a,*}, H.A. van Veen^b, H. Vietsch^b, M. Salaheddine^b,
J.H. Nuijens^b, B. Ziere^b, F. de Loos^b

^a TNO Quality of Life, Business Unit Toxicology and Applied Pharmacology, P.O. Box 360, 3700 AJ Zeist, The Netherlands

^b Pharming Technologies B.V., Leiden, The Netherlands

Received 6 June 2005; accepted 27 November 2005

Abstract

The oral toxicity of recombinant human lactoferrin (rhLF) produced in the milk of transgenic cows was investigated in Wistar rats by daily administration via oral gavage for 13 consecutive weeks, 7 days per week. The study used four groups of 20 rats/sex/dose. The control group received physiological saline and the three test groups received daily doses of 200, 600 and 2000 mg of rhLF per kg body weight. Clinical observations, growth, food consumption, food conversion efficiency, water consumption, neurobehavioural testing, ophthalmoscopy, haematology, clinical chemistry, renal concentration test, urinalysis, organ weights and gross examination at necropsy and microscopic examination of various organs and tissues were used as criteria for detecting the effects of treatment. Overall, no treatment-related, toxicologically significant changes were observed. The few findings that may be related to the treatment (lower cholesterol in high-dose females, lower urinary pH in high-dose males and females and very slightly higher kidney weight in high-dose females) were considered of no toxicological significance.

Based on the absence of treatment-related, toxicologically relevant changes, the no-observed-adverse-effect level (NOAEL) was considered to be at least 2000 mg/kg body weight/day.

Keywords: Recombinant human lactoferrin; Oral administration; Rats; Repeated dose toxicity study

1. Introduction

Human lactoferrin (hLF) is a single-chain metal-binding 77-kDa glycoprotein that belongs to the transferrin family (Anderson et al., 1989). Lactoferrin (LF) consists of two highly homologous lobes, designated the N- and C-lobe, each of which can bind a single ferric ion concomitantly with one bicarbonate anion (Anderson et al., 1989). The molecule is found in milk, tears, saliva, bronchial and intestinal secretions as well as in the secondary granules of neutrophils (Nuijens et al., 1996). Extensive in vitro and in vivo

studies showed LF to have antibacterial, antifungal, antiviral and anti-inflammatory activities. On the basis of these activities, LF is postulated to be involved in the innate host defence against infection and severe inflammation, most notable at mucosal surfaces such as those of the gastrointestinal tract (Nuijens et al., 1996). Antimicrobial activities of LF include bacteriostasis by iron deprivation (Reiter et al., 1975), bactericidal activity by destabilization of the cell-wall (Ellison et al., 1988; Ellison and Giehl, 1991) and antiviral activity by inhibition of viral infection (van der Strate et al., 2001). Anti-inflammatory actions of LF include inhibition of hydroxyl-radical formation (Sanchez et al., 1992), of complement activation (Kijlstra and Jeurissen, 1982) and of cytokine production (Zucali et al., 1989) as well as neutralization of lipopolysaccharide (LPS; Lee et al., 1998). Besides antimicrobial activity, LF has been

Abbreviations: LF, lactoferrin; hLF, human LF; rhLF, recombinant hLF; bLF, bovine LF; NOAEL, no-observed-adverse-effect level.

*Corresponding author. Tel.: +31 30 694 44 87; fax: +31 30 696 02 64.

E-mail address: appel@voeding.tno.nl (M.J. Appel).

shown to promote the growth of *Bifidobacterium* species, the predominant bacteria of the intestinal flora of healthy breast-fed infants (Petschow and Talbott, 1991). In addition, LF has been shown to promote the growth of intestinal cells both *in vitro* (Nichols et al., 1987) as well as *in vivo* (Zhang et al., 2001), which may be mediated through binding to specific receptors (Ashida et al., 2004).

Most of the biological actions of LF are mediated by the sequestration of iron or by a positively charged domain located in the N-terminus which binds to negatively charged ligands such as LPS (Appelmelk et al., 1994), DNA (He and Furmanski, 1995) and heparin (Mann et al., 1994), as well as to specific receptors (Ashida et al., 2004; Ziere et al., 1993; Legrand et al., 1997). The release of a N-terminal fragment from LF by pepsin action yields a potent bactericidal peptide (lactoferricin) against Gram-positive and -negative bacteria, yeast and molds (Tomita et al., 1994).

A wide variety of applications of LF in human health care are possible due to the diverse biological actions of the molecule. Both bovine LF (bLF) and hLF could be used as a component of nutritional products aimed at the prevention and treatment of gastro-intestinal tract infection and inflammation. In nutraceutical applications, hLF may be preferred over bLF as it is less susceptible to proteolysis by digestive proteases like trypsin (Brines and Brock, 1983; van Veen et al., 2004) which is relevant as LF may have to survive the harsh environment of the gastro-intestinal tract.

Recently, we reported the production of recombinant hLF (rhLF) in the milk of transgenic cows (van Berkel et al., 2002). Comparative studies between rhLF and hLF from human milk revealed almost identical protein structures, identical iron-binding and release properties and, despite differences in N-linked glycosylation, similar effectiveness in various infection models (van Berkel et al., 2002; Thomassen et al., 2005). Here we report on toxicological studies of rhLF in rats, which were orally dosed rhLF for 13 consecutive weeks. Based on the absence of treatment-related, toxicologically relevant changes, the no-observed-adverse-effect level (NOAEL) is considered to be at least 2000 mg/kg body weight/day.

2. Material and methods

2.1. Production of rhLF

The production of rhLF from the milk of transgenic cows has been described previously (van Berkel et al., 2002). Briefly, a genomic hLF sequence under control of regulatory elements from the bovine αS_1 casein gene, was introduced into the bovine germline. The resulting transgenic cattle lines showed rhLF expression levels between 0.4 and 2.5 g/L (van Berkel et al., 2002). Various batches of the test-substance were produced by freeze-drying of the LF fraction (containing rhLF and bLF), extracted from mature transgenic milk using S Sepharose (van Berkel et al., 2002). The purity of rhLF was assessed by SDS-PAGE, analytical Mono S chromatography and specific ELISAs for hLF and bLF (van Berkel et al., 2002). The purity of rhLF in the LF batches was about 95%; the amount

of bLF was about 4%. Absorbance measurements revealed the LF to be saturated with iron for about 7%.

2.2. Animals

The study was performed in compliance with Good Laboratory Practice and according to current FDA and OECD Guidelines for toxicity testing (FDA, 1982; OECD, 1998). The study was conducted with 85 male and 85 female SPF Wistar outbred (CrI:(WI)WU BR) rats (Charles River Deutschland, Germany). Pre-test neurobehavioural testing was conducted in the 13-week study on animals of 5–6 weeks of age. At the start of the treatment period the rats were approximately 7 weeks old. Body weights at the start of the treatment ranged from 140.9 g to 187.0 g (mean 158.4 g) in males and from 131.0 g to 168.1 g (mean 147.2 g) in females. The animals were housed under conventional conditions in one room, in macrolon cages, with sterilized wood shavings as bedding material, 5 rats per cage, separated by sex. The room was ventilated with about 10 air changes per hour and was maintained at a temperature of 22 ± 4 °C. The room was set at a relative humidity of 30–70%. Lighting was artificial with a sequence of 12 h light and 12 h dark. Water and powdered diet (Rat & Mouse No. 3 Breeding Diet, RM3; SDS Special Diets Services, England) were provided *ad libitum*.

2.3. Administration of rhLF, experimental groups and dose levels

Recombinant hLF was administered by oral gavage as a dilution in physiological saline (0.9% NaCl) once daily for at least 90 consecutive days. The rats of the various groups were dosed with different concentrations of the test substance in the vehicle, to ensure a constant dose-volume of 10 ml per kg body weight per day at all dose levels. Controls were treated with the vehicle only. Once per week the dose volumes were adjusted to the latest recorded body weight for each individual rat, to maintain a constant dose level in terms of the animal's body weight. Fresh dilutions of the test substance in the vehicle were made daily, just prior to treatment. The rhLF was dissolved in warm physiological saline (approx. 37 °C). Four groups of 20 males and 20 females each were used, viz. one vehicle control group and three test groups receiving 200, 600 or 2000 mg rhLF per kg body weight per day for 13 consecutive weeks. The concentrations in the dosing solutions were corrected for the slight differences in purity of the various batches of rhLF.

2.4. Observations, measurements and examinations

2.4.1. General clinical signs were observed daily

Body weights and food consumption were recorded weekly and water consumption was recorded over 4-day periods in weeks 1, 6 and 12 of the study.

Neurobehavioural testing was conducted in 10 rats/sex/group. Arena testing was conducted prior to the first exposure and then once weekly up to and including week 12. Signs noted included changes in skin, fur, eyes, mucous membranes, occurrence of secretions and excretions, autonomic activity, gait, posture, response to handling and presence of clonic or tonic movements, stereotypies and bizarre behaviour. At the end of the study, Functional Observational Battery (FOB) tests and spontaneous motor activity measurements were performed in week 13 (Mosser et al., 1997). Food and water were not available during this testing.

Ophthalmoscopic observations were made prior to the start of treatment in all animals and towards the end of the treatment period in all surviving animals of the control group and the high-dose group. Eye examinations were carried out using an ophthalmoscope after induction of mydriasis by a solution of atropine sulphate.

At necropsy at the end of treatment, blood samples were taken from the abdominal aorta of 10 rats per sex per group, whilst under CO₂/O₂-anaesthesia. K₂-EDTA (haematology) or heparin (clinical chemistry) were used as anticoagulants. Fasting glucose was determined shortly before the end of the treatment period in blood collected from the tip of the tail. As required by FDA and OECD Guidelines, haematology and clinical

chemistry parameters were determined according to well established methods (FDA, 1982; OECD, 1998).

Shortly before the end of the treatment, 10 rats per sex per group (the same as those used for haematology and clinical chemistry) were deprived of water for 24 h and of food during the last 16 h of this period. During the last 16 h of deprivation, the rats were kept in stainless steel metabolism cages (one rat per cage) and urine was collected. The concentrating ability of the kidneys was investigated by measuring the volume and density of the individual samples. Urinalysis was conducted as required by FDA and OECD Guidelines (FDA, 1982; OECD, 1998).

At the end of the treatment period, all animals were subjected to a complete gross necropsy. The animals were killed by exsanguination from the abdominal aorta under CO₂/O₂-anaesthesia and then examined grossly for pathological changes. A large number of organs and tissues were excised, weighed, collected and preserved, as required by FDA and OECD guidelines (FDA, 1982; OECD, 1998).

The tissues to be examined microscopically were embedded in paraffin wax, sectioned at 5 µm and stained with haematoxylin and eosin. Histopathological examination was performed on all animals of the control group and of the high-dose group (including the animal that was killed *in extremis*). In addition, the lungs, liver, kidneys and gross lesions were examined microscopically in all rats of the intermediate dose-groups.

The statistical procedures included analysis of covariance, (non-parametric) analysis of variance and the Fisher's exact probability test, where appropriate.

3. Results

No treatment-related clinical signs were observed. One high-dose female was killed *in extremis*, due to posterior paralysis. This condition was not considered related to treatment.

Body weights were similar among the groups throughout the study. Food consumption and food conversion efficiency were similar among the groups throughout the study. The mean weekly food consumption ranged from 18.3 to 19.5 g/rat/day in males and from 12.6 to 12.9 g/rat/day in females. The mean weekly food conversion efficiency was 0.14 g weight gain/g food consumed in males and 0.07 g weight gain/g food consumed in females.

Water consumption and urinalysis results are shown in Table 1. Water consumption was similar among the groups throughout the study. Urinary density was statistically significantly higher in males of the high-dose group. Urinary pH was statistically significantly decreased in males and females of the high-dose group. Urinary crystals were statistically significantly increased in males of the low- and

Table 1
Water intake and urinary findings in rats after 13 weeks of repeated oral administration of recombinant human lactoferrin (rhLF)

		Water intake (ml/day)	Volume (ml)	Density (kg/l)	Apprnc-U	pH-U	Prot-U (0-3)	Gluc-U (0-4)	Keton-U (0-3)	Oc.Bld-U (0-3)	Urobil-U (0-4)	Biliru-U (0-3)
<i>Males</i>												
Control	Mean	27.3	4.8	1.036	Yellow	7.2	1	0	0	0	0	0
	sem		0.5	0.002								
	<i>n</i>		10	10	10	10	10	10	10	10	10	10
0.2 g/kg	Mean	29.2	4.5	1.042	Yellow	7.0	1	0	0	0	0	0
	sem		0.4	0.003								
	<i>n</i>		10	10	10	10	10	10	10	10	10	10
0.6 g/kg	Mean	28.9	5.0	1.038	Yellow	7.3	1	0	0	0	0	0
	sem		0.4	0.002								
	<i>n</i>		10	10	10	10	10	10	10	10	10	10
2.0 g/kg	Mean	29.0	4.4	1.048**	Yellow	6.6**	1	0	0	0	0	0
	sem		0.5	0.003								
	<i>n</i>		10	10	10	10	10	10	10	10	10	10
<i>Females</i>												
Control	Mean	22.5	2.4	1.050	Yellow	6.4	0	0	0	0	0	0
	sem		0.2	0.003								
	<i>n</i>		10	10	10	10	10	10	10	10	10	10
0.2 g/kg	Mean	23.0	3.0	1.049	Yellow	6.5	1	0	0	1	0	0
	sem		0.5	0.004								
	<i>n</i>		10	10	10	10	10	10	10	10	10	10
0.6 g/kg	Mean	21.9	2.6	1.049	Yellow	6.2	0	0	0	0	0	0
	sem		0.3	0.004								
	<i>n</i>		10	10	10	10	10	10	10	10	10	10
2.0 g/kg	Mean	23.4	2.3	1.057	Yellow	5.8*	0	0	0	0	0	0
	sem		0.2	0.002								
	<i>n</i>		10	10	10	10	10	10	10	10	10	10

Statistics: One-way analysis of variance followed by Dunnett's multiple comparison tests; * $P < 0.05$, ** $P < 0.01$; or in case of non-continuous parameters: Kruskal-Wallis non-parametric analysis of variance followed by Mann-Whitney U-tests; * $P < 0.05$, ** $P < 0.02$, *** $P < 0.002$.

Apprnc-U: Appearance urine; pH-U: pH urine; prot-U: Protein in urine; Gluc-U: Glucose in urine; Keton-U: Ketones in urine; Oc.Bld-U: Occult blood in urine; Urobil-U: Urobilinogen in urine; Biliru-U: Bilirubin in urine.

Table 2
Haematological findings in rats after 13 weeks of repeated oral administration of recombinant human lactoferrin (rhLF)

	RBC 10E12/l	HB (mmol/l)	PCV (l/l)	MCV (fl)	MCH (fmol)	MCHC (mmol/l)	Reticulocyte/ 1000	Thromboc 10E9/l	PTT (s)	Eosinoph (%)	Neutroph (%)	Lymphoc (%)	Monocyt (%)	Basophil (%)
<i>Males</i>														
Control	Mean sem <i>n</i>	9.6 0.1 10	0.421 0.006 10	51.5 0.8 10	1.17 0.02 10	22.8 0.1 10	37.3 1.5 10	958 34 10	42.7 0.5 10	0.9 0.3 10	6.7 1.2 10	91.5 1.2 10	0.8 0.2 10	0.1 0.1 10
0.2 g/kg	Mean sem <i>n</i>	9.6 0.1 10	0.422 0.007 10	52.1 0.5 10	1.18 0.01 10	22.8 0.1 10	36.5 0.8 10	948 18 10	42.7 0.9 10	0.6 0.2 10	6.1 1.2 10	92.6 1.2 10	0.7 0.3 10	0.0 0.0 10
0.6 g/kg	Mean sem <i>n</i>	9.3 0.1 10	0.411 0.003 10	51.3 0.5 10	1.16 0.01 10	22.6 0.1 10	39.2 2.4 10	975 21 10	41.4 0.7 10	0.6 0.2 10	8.3 1.0 10	90.6 0.9 10	0.5 0.2 10	0.0 0.0 10
2.0 g/kg	Mean sem <i>n</i>	9.5 0.2 10	0.417 0.007 10	52.1 0.5 10	1.19 0.01 10	22.8 0.1 10	36.8 1.3 10	940 20 10	41.5 0.4 10	0.6 0.3 10	7.6 1.8 10	91.7 1.8 10	0.4 0.2 10	0.0 0.0 10
<i>Females</i>														
Control	Mean sem <i>n</i>	9.4 0.1 10	0.408 0.005 10	54.8 0.6 10	1.27 0.01 10	23.1 0.2 10	46.4 1.8 10	815 24 10	34.6 0.5 10	0.3 0.2 10	7.2 1.5 10	92.0 1.7 10	0.4 0.2 10	0.1 0.1 10
0.2 g/kg	Mean sem <i>n</i>	9.5 0.1 10	0.408 0.004 10	53.1 0.3 10	1.23** 0.01 10	23.2 0.1 10	39.6 1.0 10	748 15 10	34.9 0.5 10	0.8 0.3 10	9.3 2.3 10	89.4 2.3 10	0.4 0.2 10	0.1 0.1 10
0.6 g/kg	Mean sem <i>n</i>	9.3 0.1 10	0.407 0.004 10	53.9 0.5 10	1.24* 0.01 10	22.9 0.1 10	43.7 1.7 10	803 16 10	34.3 0.5 10	0.6 0.3 10	11.1 2.8 10	87.4 2.9 10	0.9 0.3 10	0.0 0.0 10
2.0 g/kg	Mean sem <i>n</i>	9.4 0.1 10	0.409 0.006 10	54.5 0.5 10	1.26 0.01 10	23.1 0.1 10	43.6 2.3 10	797 22 10	36.0 0.4 10	0.4 0.2 10	8.6 1.3 10	90.7 1.3 10	0.3 0.2 10	0.0 0.0 10

Statistics: One-way analysis of variance followed by Dunnett's multiple comparison tests; * $P < 0.05$, ** $P < 0.01$; or in case of non-continuous parameters: Kruskal-Wallis non-parametric analysis of variance followed by Mann-Whitney U-tests; * $P < 0.05$, ** $P < 0.02$, *** $P < 0.002$.

RBC: Red blood cells; HB: Haemoglobin; PCV: Packed cell volume; MCV: Mean corpuscular volume; MCH: Mean corpuscular haemoglobin; MCHC: Mean corpuscular haemoglobin concentration; Reticulo: Reticulocytes; Thromboc: Thrombocytes; PTT: Prothrombin time; Eosinoph: Eosinophils; Neutroph: Neutrophils; Lymphoc: Lymphocytes; Monocyt: Monocytes; Basophil: Basophils.

Table 3
Clinical chemistry findings in rats after 13 weeks of repeated oral administration of recombinant human lactoferrin (rhLF)

	Gluc (mmol/l)	ALP (U/l)	ALAT (U/l)	ASAT (U/l)	GGT (U/l)	TP (g/l)	Albumin (g/l)	A/G ratio	Urea (mmol/l)	Creatinine (µmol/l)	Bili-Tot (µmol/l)	Cholest (mmol/l)	Triglyc (mmol/l)	Phos-lip (mmol/l)	Ca (mmol/l)	K (mmol/l)	Na (mmol/l)	Cl (mmol/l)	Inorg-P (mmol/l)	
<i>Males</i>																				
Control	Mean	3.88	134	54	48	0.2	71	44	1.66	7.6	28	0.4	1.55	2.02	3.13	5.1	151	100	2.26	
	sem	0.07	7	2	2	0.1	1	0	0.03	0.3	0	0.1	0.18	0.07	0.03	0.1	0	0	0.07	
	<i>n</i>	10	10	10	10	10	10	10	10	10	10	10	10	10	10	10	10	10	10	10
0.2 g/kg	Mean	3.85	117	48	48	0.1	72	45	1.62	7.5	27	0.2	1.44	1.89	3.12	5.1	152	100	2.20	
	sem	0.05	6	3	1	0.1	0	0	0.02	0.2	0	0.1	0.10	0.05	0.02	0.1	0	0	0.06	
	<i>n</i>	10	10	10	10	10	10	10	10	10	10	10	10	10	10	10	10	10	10	10
0.6 g/kg	Mean	3.88	116	49	50	0.0	70	43*	1.56	7.6	27	0.4	1.69	2.00	3.07	5.2	151	100	2.14	
	sem	0.12	6	2	2	0.0	1	0	0.06	0.3	1	0.1	0.29	0.10	0.02	0.1	0	0	0.07	
	<i>n</i>	10	10	10	10	10	10	10	10	10	10	10	10	10	10	10	10	10	10	10
2.0 g/kg	Mean	4.01	115	53	55	0.1	72	44	1.58	7.4	27	0.5	1.44	1.93	3.13	5.2	151	100	2.29	
	sem	0.21	5	2	2	0.1	1	0	0.03	0.2	1	0.1	0.17	0.08	0.04	0.1	1	0	0.08	
	<i>n</i>	10	10	10	10	10	10	10	10	10	10	10	10	10	10	10	10	10	10	10
<i>Females</i>																				
Control	Mean	3.74	127	72	78	0.6	73	49	2.11	7.0	39	1.7	1.32	2.55	3.03	5.2	152	99	2.35	
	sem	0.09	8	4	3	0.1	1	1	0.05	0.3	1	0.3	0.20	0.09	0.04	0.1	1	1	0.12	
	<i>n</i>	10	10	10	10	10	10	10	10	10	10	10	10	10	10	10	10	10	10	10
0.2 g/kg	Mean	3.64	117	66	73	0.5	73	50	2.19	7.0	37	1.6	1.48	2.58	3.07	5.0	150	100	2.51	
	sem	0.09	7	3	4	0.1	1	0	0.05	0.2	1	0.2	0.36	0.10	0.03	0.1	0	1	0.06	
	<i>n</i>	10	10	10	10	10	10	10	10	10	10	10	10	10	10	10	10	10	10	10
0.6 g/kg	Mean	4.01	138	64	75	0.5	74	50	2.09	6.8	37	1.5	1.31	2.34	3.05	4.9	151	100	2.42	
	sem	0.15	8	3	3	0.1	1	0	0.06	0.3	1	0.2	0.21	0.06	0.03	0.1	0	1	0.09	
	<i>n</i>	10	10	10	10	10	10	10	10	10	10	10	10	10	10	10	10	10	10	10
2.0 g/kg	Mean	3.49	128	69	78	0.6	71	48	2.06	7.2	37	1.5	1.09	2.30	3.06	5.2	150	100	2.62	
	sem	0.09	10	3	3	0.1	1	1	0.04	0.2	1	0.1	0.13	0.09	0.03	0.1	1	0	0.10	
	<i>n</i>	10	10	10	10	10	10	10	10	10	10	10	10	10	10	10	10	10	10	10

Statistics: One-way analysis of variance followed by Dunnett's multiple comparison tests; * $P < 0.05$, ** $P < 0.01$; or in case of non-continuous parameters: Kruskal-Wallis non-parametric analysis of variance followed by Mann-Whitney U-tests; * $P < 0.05$, ** $P < 0.02$, *** $P < 0.002$.

Gluc: Glucose; ALP: Alkaline phosphatase; ALAT: Alanine aminotransferase (GPT); ASAT: Aspartate aminotransferase (GOT); GGT: Gamma glutamyl transferase; TP: Total protein; Album: Albumin; A/G Ratio: Albumin/globulin ratio; Urea: Urea in plasma; Creatinine: Creatinine; Bili-Tot: Bilirubin (total); Cholest: Cholesterol (total); Triglyc: Triglycerides; Phos-lip: Phospholipids; Ca: Calcium; K: Potassium; Na: Sodium; Cl: Chloride; Inorg-P: Inorganic phosphate.

mid-dose groups (data not shown). Further semi-quantitative and microscopic urinary observations were similar among the groups (data not shown).

The results of functional observational battery (FOB) testing did not show significant changes that were considered to be related to treatment. A minor statistically significant difference between groups was found for hindlimb gripstrength in females (ANOVA, $F = 2.94$, $p < 0.05$). However, post-hoc group comparisons showed that none of the treated groups was significantly different from the control group.

With respect to motor activity, analysis of variance of the total distance moved of males indicated a significant difference between groups (ANOVA, $F = 3.16$, $p < 0.05$). Analysis of variance indicated also a significant difference between groups for the number of movements of males (ANOVA, $F = 3.06$, $p < 0.05$). However, post-hoc group comparisons showed that none of the treated groups was significantly different from the control group for both measures. For females a significant difference between groups was found for the mean velocity (ANOVA, $F = 2.91$, $p < 0.05$). Also in this case, post-hoc group comparisons showed that none of the treated groups was significantly

different from the control group. Finally, no effects on habituation were observed. Overall, no treatment-related changes were observed during the neurobehavioural testing of males and females at arena testing during the study and FOB and motor activity assessment at the end of the study. Therefore, no evidence was obtained for a neurotoxic potential of the test substance.

Ophthalmoscopic observations revealed no treatment-related ocular changes.

Results of the haematological examinations are given in Table 2. Mean Corpuscular Haematology was statistically significantly lower in females of the low- and mid-dose groups. No other statistically significant changes were observed.

Results of the clinical chemistry examinations are given in Table 3. Albumin was statistically significantly lower in males of the mid-dose group. Cholesterol was statistically significantly lower in females of the high-dose group. No other statistically significant changes in clinical chemistry parameters were observed.

Absolute and relative organ weights are shown in Tables 4 and 5. Absolute adrenal weights were higher in males of the low- and high-dose groups, absolute kidney weights

Table 4
Absolute organ weights (g) in rats after 13 weeks of repeated oral administration of recombinant human lactoferrin (rhLF)

		TermBW (g)	Thyroid (g)	Adrenals (g)	Kidneys (g)	Thymus (g)	Brain (g)	Spleen (g)	Heart (g)	Liver (g)	Testes (g)	Epididym (g)
<i>Males</i>												
Control	Mean	385.7	0.023	0.044	2.24	0.381	1.87	0.675	1.17	12.92	3.21	1.31
	sem	5.9	0.001	0.001	0.04	0.023	0.02	0.015	0.02	0.27	0.07	0.02
	n	20	20	20	19	20	20	20	20	20	20	20
0.2 g/kg	Mean	405.7	0.022	0.048*	2.35	0.439	1.90	0.709	1.25	13.98*	3.32	1.36
	sem	5.8	0.001	0.001	0.04	0.022	0.02	0.015	0.03	0.29	0.08	0.03
	n	20	19	20	20	20	20	20	20	20	20	20
0.6 g/kg	Mean	411.4*	0.024	0.047	2.41**	0.405	1.93	0.718	1.27	14.11*	3.25	1.33
	sem	7.4	0.001	0.001	0.03	0.021	0.02	0.018	0.03	0.31	0.10	0.02
	n	20	20	20	20	20	20	20	20	20	20	20
2.0 g/kg	Mean	397.5	0.023	0.048*	2.37*	0.385	1.91	0.693	1.23	13.76	3.28	1.33
	sem	6.4	0.001	0.001	0.04	0.020	0.02	0.014	0.02	0.36	0.07	0.02
	n	20	20	20	19	20	20	20	20	20	20	20
<i>Females</i>											Ovaries (g)	Uterus (g)
Control	Mean	229.1	0.020	0.060	1.42	0.279	1.76	0.463	0.80	7.50	0.080	0.691
	sem	3.3	0.001	0.001	0.02	0.009	0.01	0.013	0.01	0.17	0.002	0.053
	n	20	20	20	20	20	20	20	20	20	20	20
0.2 g/kg	Mean	232.4	0.020	0.060	1.51	0.288	1.76	0.447	0.79	7.78	0.079	0.687
	sem	2.7	0.001	0.001	0.03	0.012	0.01	0.012	0.01	0.24	0.002	0.045
	n	20	20	20	19	20	20	20	20	20	20	20
0.6 g/kg	Mean	231.6	0.021	0.063	1.50	0.297	1.74	0.458	0.82	7.88	0.084	0.703
	sem	2.8	0.001	0.002	0.02	0.010	0.01	0.013	0.02	0.22	0.003	0.061
	n	20	20	19	20	20	20	20	20	20	20	20
2.0 g/kg	Mean	233.0	0.020	0.063	1.53**	0.292	1.78	0.490	0.83	7.96	0.082	0.606
	sem	2.8	0.001	0.002	0.03	0.009	0.02	0.010	0.02	0.21	0.002	0.043
	n	19	19	19	19	19	19	19	19	19	19	19

Statistics: One-way analysis of variance followed by Dunnett's multiple comparison tests; * $P < 0.05$, ** $P < 0.01$.

TermBW: Terminal Body Weight.

Table 5
Relative organ weights (g/kg body weight) in rats after 13 weeks of repeated oral administration of recombinant human lactoferrin (rhLF)

	TermBW (g)	Thyroid (g/kg BW)	Adrenals (g/kg BW)	Kidneys (g/kg BW)	Thymus (g/kg BW)	Brain (g/kg BW)	Spleen (g/kg BW)	Heart (g/kg BW)	Liver (g/kg BW)	Testes (g/kg BW)	Epididymus (g/kg BW)
<i>Males</i>											
Control	Mean	385.7	0.060	5.81	0.99	4.86	1.75	3.04	33.5	8.35	3.41
	sem	5.9	0.002	0.10	0.06	0.07	0.03	0.04	0.4	0.21	0.06
<i>n</i>	20	20	20	19	20	20	20	20	20	20	20
0.2 g/kg	Mean	405.7	0.056	5.80	1.08	4.70	1.75	3.08	34.5	8.18	3.36
	sem	5.8	0.002	0.09	0.06	0.05	0.03	0.07	0.5	0.20	0.08
<i>n</i>	20	19	20	20	20	20	20	20	20	20	20
0.6 g/kg	Mean	411.4*	0.057	5.88	0.98	4.72	1.75	3.09	34.3	7.96	3.26
	sem	7.4	0.002	0.08	0.04	0.07	0.04	0.06	0.5	0.28	0.07
<i>n</i>	20	20	20	20	20	20	20	20	20	20	20
2.0 g/kg	Mean	397.5	0.059	5.99	0.97	4.84	1.75	3.09	34.5	8.30	3.36
	sem	6.4	0.002	0.06	0.05	0.08	0.03	0.04	0.6	0.24	0.07
<i>n</i>	20	20	20	19	20	20	20	20	20	20	20
<i>Females</i>											
Control	Mean	229.1	0.086	6.20	1.22	7.72	2.03	3.50	32.8	0.351	3.04
	sem	3.3	0.004	0.08	0.04	0.09	0.06	0.08	0.8	0.011	0.25
<i>n</i>	20	20	20	20	20	20	20	20	20	20	20
0.2 g/kg	Mean	232.4	0.088	6.49	1.24	7.60	1.92	3.38	33.5	0.342	2.96
	sem	2.7	0.004	0.10	0.05	0.09	0.04	0.04	1.0	0.010	0.19
<i>n</i>	20	20	20	19	20	20	20	20	20	20	20
0.6 g/kg	Mean	231.6	0.090	6.46	1.28	7.54	1.98	3.56	34.0	0.360	3.04
	sem	2.8	0.005	0.07	0.04	0.06	0.05	0.05	0.8	0.012	0.27
<i>n</i>	20	20	19	20	20	20	20	20	20	20	20
2.0 g/kg	Mean	233.0	0.086	6.58**	1.25	7.65	2.11	3.55	34.1	0.351	2.62
	sem	2.8	0.004	0.10	0.03	0.09	0.04	0.08	0.7	0.011	0.19
<i>n</i>	19	19	19	19	19	19	19	19	19	19	19

Statistics: One-way analysis of variance followed by Dunnett's multiple comparison tests; * $P < 0.05$, ** $P < 0.01$.

TermBW: Terminal body weight.

were higher in males of the mid-dose group and in males and females of the high dose group, relative kidney weights were higher in females of the high-dose group and absolute liver weights were higher in males of the low- and mid-dose groups.

Results of histopathological examinations are shown in Table 6. No treatment-related gross lesions were observed

at necropsy. All lesions observed were about equally distributed among the groups, or they occurred in a single animal only. The accessory lobe of the lung of the high-dose female animal that was killed *in extremis* (due to posterior paralysis), showed a large haemorrhage. Microscopic examination did not reveal any treatment-related changes. All changes observed were about equally distributed between

Table 6
Histopathological findings in rats ($N = 20$) after 13 weeks of repeated oral administration of recombinant human lactoferrin (rhLF)

Organ or tissue examined/changes found	Incidence of lesions							
	Males				Females			
	Control	Low-dose	Mid-dose	High-dose	Control	Low-dose	Mid-dose	High-dose
Brain/Hydrocephalus	–	–	–	–	–	1	–	–
Epididymides/focal mononuclear cell infiltrate	1	–	–	4	0	–	–	0
GALT (Peyer's patches)/focal calcification	1	–	–	0	0	–	–	0
Heart/cartilaginous metaplasia	1	–	–	0	–	–	–	–
Heart/focal subepicardial mononuclear cell infiltrate	2	–	–	3	–	–	–	–
Heart/focal myocardial mononuclear cell infiltrate	1	–	–	2	1	–	–	1
Kidneys/few proteinaceous casts	1	0	0	0	0	0	0	0
Kidneys/basophilic tubules	13	12	15	15	1	3	2	1
Kidneys/focal mononuclear cell infiltrate	1	2	0	1	0	1	0	0
Kidneys/cortical mineralization	0	0	0	0	2	0	0	0
Kidneys/corticomedullary mineralization	0	0	0	0	2	3	4	3
Kidneys/pelvic (epithelial) mineralization	2	2	2	1	3	0	1	0
Kidneys/medullary mineralization	1	1	0	1	3	1	1	0
Kidneys/focal transitional cell hyperplasia	3	1	2	1	0	0	0	0
Kidneys/hydronephrosis	3	0	0	1	0	2	0	3
Kidneys/cysts	1	0	0	0	0	0	0	0
Kidneys/pyelitis	0	0	0	0	0	1	0	0
Liver/mononuclear cell aggregates/necrotic hepatocytes	10	7	7	11	9	9	12	10
Liver/periportal mononuclear cell infiltrate	0	0	0	1	0	0	0	0
Liver/vacuolated focus	0	0	0	1	0	0	0	0
Liver/focal hepatocellular necrosis	0	0	0	0	1	0	1	1
Lungs/focal alveolitis	0	0	0	1	0	0	0	1
Lungs/accumulation of alveolar macrophages	0	1	0	0	0	0	1	3
Lungs/focal pneumonia	0	0	0	0	0	0	0	1
Lungs/focal haemorrhage(s)	0	0	0	0	0	0	0	1
Lungs/perivascular polymorphonuclear leukocytic infiltration	0	0	0	0	0	0	1	0
Lungs/granulomatoma	0	0	0	0	0	0	1	0
Mesenteric lymph nodes/germinal centre development	8	–	–	5	9	–	–	10
Ovaries/focal mineralization					4	–	–	3
Ovaries/cyst(s)					3	–	–	4
Pancreas/focal mononuclear cell infiltrate	1	–	–	0	1	–	–	2
Pituitary/pars disalis cyst(s)	4	–	–	4	0	–	–	0
Prostate/focal mononuclear cell infiltrate	0	–	–	2				
Skin/focal acanthosis	0	–	–	0	1	–	1 ^a	0
Skin/focal hypotrichosis	0	–	–	0	0	–	1 ^a	0
Small intestines/focal enteritis	1	–	–	0	0	–	–	0
Spleen/increased extramedullary haematopoiesis	0	–	–	1	3	–	–	2
Subling. + submax. Salivary glands/focal parotid-type acini	3	–	–	2	2	–	–	3
Testes/seminiferous tubular atrophy	2	–	–	2				
Thymus/microhaemorrhage(s)	6	–	1 ^a	1	0	–	–	3
Thymus/focal ductular structures	2	–	–	1	14	–	–	11
Thymus/cortical lymphoid depletion	0	0	0	0	0	–	–	1
Thyroid/focal mononuclear cell infiltrate	0	–	–	0	1	–	–	0
Trachea/bronchi/focal mononuclear cell infiltrate	0	–	–	2	1	–	–	0
Uterus/luminal dilatation					7	–	–	6

No abnormalities detected in: adrenals, aorta, caecum, cervical lymph nodes, colon, eyes, mammary glands, peripheral nerve, oesophagus, parathyroids, rectum, spinal cord, sternum with bone marrow, stomach, urinary bladder.

^a Apart from kidneys, liver and lungs only gross lesions were microscopically examined in the intermediate dose groups.

the controls and the groups given the test substance, or occurred in a single or a few animals only. Moreover, they are common findings for the strain and age of rats used. Microscopy of the animal that was killed *in extremis* during the experiment revealed a pneumonia and haemorrhage of the lungs, focal hepatocellular necrosis and a cortical lymphoid depletion in the thymus (stress involution).

4. Discussion and conclusion

A wide variety of applications of human lactoferrin (hLF) in human health care are possible due to its antimicrobial and anti-inflammatory activities (Nuijens et al., 1996). In nutraceutical applications, hLF could be used as a component of products aimed at the prevention and treatment of gastro-intestinal tract infection and inflammation. In the present study the toxicity of recombinant hLF (rhLF) in Wistar rats was examined upon daily administration via oral gavage for 13 consecutive weeks up to a dose level of 2000 mg/kg body weight/day. Overall no treatment-related toxicity was observed. The few minor changes found are discussed below. The posterior paralysis observed in the female animal killed *in extremis*, was not considered related to treatment. Although the cause of the moribund condition could not be definitively established, it was most probably related to trauma possibly caused by the dosing procedure. The lower MCH in females of the low- and mid-dose groups was considered a chance finding, since a similar change was absent in the high-dose group. The lower albumin level in males of the mid-dose group was considered a chance finding in the absence of a similar change in the high-dose group. It cannot be excluded that the lower cholesterol level in females of the high-dose group was related to the treatment, but it was only minor and was well within the range of normal control values. For this reason the change was not considered of toxicological significance. The higher urinary density was related to the slightly (non-significant) lower urinary volume in males of the high-dose group. This change was considered of no toxicological relevance, since a decrease in urinary density is not an indication for impaired renal concentrating ability. Moreover, the change was minor and within the range of the normal control values. The lower urinary pH in males and females of the high-dose group was probably treatment-related. A similar change was previously observed in rats given bovine lactoferrin at the same dose level (2000 mg/kg/day) for 13 weeks (Yamauchi et al., 2000). The change was consistent with a non-specific decrease in pH, possibly as a result of high protein exposure and was considered of no toxicological relevance. The increase in urinary crystals in males of the low- and mid-dose groups was considered an incidental finding in the absence of a similar change in the high-dose group. The higher absolute adrenal weights in males of the low- and high-dose groups were considered incidental findings, since no significant differences were observed in relative adrenal weights and no histopathological changes were

seen in this organ. The higher absolute kidney weights in males of the mid- and high-dose groups were not accompanied by significant changes in relative kidney weight or changes in renal histopathology. It cannot be excluded that the higher absolute and relative kidney weights in females of the high dose group were related to the treatment. However, the change was very slight (approx. 6%) and was neither accompanied by histopathological renal changes nor by changes in urinary or clinical chemistry parameters indicative of renal toxicity. For this reason, the changes in kidney weights were considered of no toxicological significance. The higher absolute liver weights in males of the low- and mid-dose groups were considered incidental findings, since a similar change was absent in the high-dose group. Moreover, relative liver weight showed no significant differences from controls.

It was concluded that based on the absence of treatment-related, toxicologically relevant changes in clinical signs, growth, food consumption, food conversion efficiency, water consumption, neurobehavioural parameters, ophthalmoscopy, haematology, clinical chemistry, renal concentrating ability, urinalysis, organ weights and pathology, the no-observed-adverse-effect level (NOAEL) was considered to be at least 2000 mg/kg body weight/day.

References

- Anderson, B.F., Baker, H.M., Norris, G.E., Rice, D.W., Baker, E.N., 1989. Structure of human lactoferrin: crystallographic structure analysis and refinement at 2.8 Å resolution. *J. Mol. Biol.* 209, 711–734.
- Appelmelk, B.J., An, Y.Q., Geerts, M., Thijs, B.G., de Boer, H.A., MacLaren, D.M., de Graaff, J., Nuijens, J.H., 1994. Lactoferrin is a lipid A-binding protein. *Infect. Immun.* 62, 2628–2632.
- Ashida, K., Sasaki, H., Suzuki, Y.A., Lönnnerdal, B., 2004. Cellular internalization of lactoferrin in intestinal epithelial cells. *BioMetals* 17, 311–315.
- van Berkel, P.H.C., Welling, M.M., Geerts, M., van Veen, H.A., Ravensbergen, B., Salaheddine, M., Pauwels, E.K.J., Pieper, F., Nuijens, J.H., Nibbering, P.H., 2002. Large scale production of recombinant human lactoferrin in the milk of transgenic cows. *Nature Biotechnol.* 20, 484–487.
- Brines, R.D., Brock, J.H., 1983. The effect of trypsin and chymotrypsin on the *in vitro* antimicrobial and iron-binding properties of lactoferrin in human milk and bovine colostrum. Unusual resistance of human apolactoferrin to proteolytic digestion. *Biochim. Biophys. Acta* 759, 229–235.
- Ellison III, R.T., Giehl, T.J., La, F.F., 1988. Damage of the outer membrane of enteric gram-negative bacteria by lactoferrin and transferring. *Infect. Immun.* 56, 2774–2781.
- Ellison III, R.T., Giehl, T.J., 1991. Killing of gram-negative bacteria by lactoferrin and lysozyme. *J. Clin. Invest.* 88, 1080–1091.
- FDA. 1982. guidelines for the testing of food additives. *Toxicological Principles for the Safety Assessment of Direct Food Additives and Color Additives Used in Food.* US Food and Drug Administration Bureau of Foods.
- He, J., Furmanski, P., 1995. Sequence specificity and transcriptional activation in the binding of lactoferrin to DNA. *Nature* 373, 721–724.
- Kijlstra, A., Jeurissen, S.H.M., 1982. Modulation of the classical C3 convertase of complement by tear lactoferrin. *Immunology* 47, 263–270.
- Lee, W.J., Farmer, J.L., Hilty, M., Kim, Y.B., 1998. The protective effects of lactoferrin feeding against endotoxin lethal shock in germfree piglets. *Infect. Immun.* 66, 1421–1426.

- Legrand, D., van Berkel, P.H.C., Salmon, V., van Veen, H.A., Slomianny, M.C., Nuijens, J.H., Spik, G., 1997. The N-terminal Arg2, Arg3 and Arg4 of human lactoferrin interact with sulphated molecules but not with the receptor present on Jurkat human lymphoblastic T-cells. *Biochem. J.* 327, 841–846.
- Mann, D.M., Romm, E., Migliorini, M., 1994. Delineation of the glycosaminoglycan-binding site in the human inflammatory response protein lactoferrin. *J. Biol. Chem.* 269, 23661–23667.
- Moser, V.C., Tilson, H.A., Macphail, R.C., Becking, G.C., Cuomo, V., Frantik, E., Kulig, B.M., Winneke, G., 1997. The IPCS collaborative study on neurobehavioral screening methods. II. Protocol design and testing procedures. *Neurotoxicology* 18 (4), 929–939.
- Nichols, B.L., McKee, K.S., Henry, J.F., Putman, M., 1987. Human lactoferrin stimulates thymidine incorporation into DNA of rat crypt cells. *Pediatr. Res.* 21, 563–567.
- Nuijens, J.H., van Berkel, P.H.C., Schanbacher, F.L., 1996. Structure and biological actions of lactoferrin. *J. Mammary Gland Biol. Neoplasia* 1, 285–295.
- OECD Guideline for the Testing of Chemicals 408 (adopted 21 September 1998).
- Petschow, B.W., Talbott, R.D., 1991. Response of bifidobacterium species to growth promoters in human and cow milk. *Pediatr. Res.* 29, 208–213.
- Reiter, B., Brock, J.H., Steel, E.D., 1975. Inhibition of *Escherichia coli* by bovine colostrum and post-colostral milk. II. The bacteriostatic effect of lactoferrin on a serum-susceptible and serum-resistant strain of *E. coli*. *Immunology* 28, 83–95.
- Sanchez, L., Calvo, M., Brock, J.H., 1992. Biological role of lactoferrin. *Arch. Dis. Child* 67, 657–661.
- Thomassen, E.A., van Veen, H.A., van Berkel, P.H., Nuijens, J.H., Abrahams, J.P., 2005. The protein structure of recombinant human lactoferrin produced in the milk of transgenic cows closely matches the structure of human milk-derived lactoferrin. *Transgenic Res.* 14, 397–405.
- Tomita, M., Takase, M., Wakabayashi, H., Bellamy, W., 1994. Antimicrobial peptides of lactoferrin. *Adv. Exp. Med. Biol.* 357, 209–218.
- van der Strate, B.W.A., Beljaars, L., Molema, G., Harmsen, M.C., Meijer, D.K.F., 2001. Antiviral activities of lactoferrin. *Antiviral Res.* 52, 225–239.
- van Veen, H.A., Geerts, M.E.J., van Berkel, P.H.C., Nuijens, J.H., 2004. The role of N-linked glycosylation in the protection of human and bovine lactoferrin against tryptic proteolysis. *Eur. J. Biochem.* 271, 678–684.
- Yamauchi, K., Toida, T., Nishimura, S., Nagano, E., Kusuoka, O., Teraguchi, S., Hayasawa, H., Shimamura, S., Tomita, M., 2000. 13-week oral repeated administration toxicity study of bovine lactoferrin in rats. *Food Chem. Toxicol.* 38, 503–512.
- Zhang, P., Sawicki, V., Lewis, A., Hanson, L., Nuijens, J.H., Neville, M.C., 2001. Human lactoferrin in the milk of transgenic mice increases intestinal growth in ten-day-old suckling neonates. *Adv. Exp. Med. Biol.* 501, 101–113.
- Ziere, G.J., Bijsterbosch, M.K., van Berkel, T.J., 1993. Removal of 14 N-terminal amino acids of lactoferrin enhances its affinity for parenchymal liver cells and potentiates the inhibition of beta—very low density lipoprotein binding. *J. Biol. Chem.* 268, 27069–27075.
- Zucali, J.R., Broxmeyer, H.E., Levy, D., Morse, C., 1989. Lactoferrin decreases monocyte-induced fibroblast production of myeloid colony-stimulating activity by suppressing monocyte release of interleukin-1. *Blood* 74, 1531–1536.

Chapter 10

Summary and general conclusions

1. Introduction

Human lactoferrin (hLF) is a metal-binding glycoprotein of Mr 77,000 that belongs to the transferrin family [1]. The molecule is found in milk, tears, saliva, bronchial and intestinal secretions as well as in the secondary granules of neutrophils [2]. Human LF consists of a single polypeptide of 692 amino acids [3] that is folded in two homologous lobes, designated the N- and C-lobe, each of which can bind a single ferric ion [1]. Furthermore, the molecule contains positively charged domains located in the N-terminus which can bind to negatively charged ligands such as heparin and LPS ([4-6], Chapter 4).

Based on in vitro and in vivo studies showing antimicrobial, anti-inflammatory and immunomodulatory activities, hLF is postulated to be involved in the innate host defence against infection and severe inflammation most notable at mucosal surfaces [2]. The antimicrobial activities of hLF include bacteriostasis by iron deprivation [7], bactericidal activity by destabilization of the cell-wall [8, 9] and antiviral activity by inhibition of viral infection [10]. The anti-inflammatory activities of hLF include inhibition of hydroxyl-radical formation by scavenging of iron [11], of mast cell tryptase activity by dissociation of the tryptase/heparin complex [12], of cytokine production [13] and of LPS activity [14, 15]. Besides down-regulation of immune reactions, hLF can also up-regulate immune responses by the activation of cells like monocytes/macrophages and NK cells [16]. These effects of hLF on cellular immunity likely are mediated by the binding of the molecule to cell-surface receptors and subsequent intracellular signaling pathways [17, 18]. Specific receptors for hLF have been found on a variety of cells including monocytes [19], lymphocytes [20], liver [21] and intestinal cells [22].

2. Applications of human lactoferrin in human healthcare

The diverse biological properties of hLF may allow for a wide variety of nutraceutical and pharmaceutical applications in human healthcare.

An interesting possibility would be to evaluate the use of hLF in the prevention or treatment of severe gastrointestinal disorders such as those occurring in patients with inflammatory bowel diseases or in patients receiving high-dose chemotherapy. These patients may benefit from the antimicrobial, anti-inflammatory and immunomodulatory activities of hLF, from its growth promotional effects on intestinal cells, from its probiotic effects e.g. through growth promotion of *Bifidobacterium* species, as well as from effects on iron uptake [2, 22-29]. These effects may also provide a basis for the application of hLF in clinical nutrition or infant formula.

Lactoferrin abolishing late phase airway responses (through inhibition of mast cell tryptase activity) in allergic sheep and decreasing pollen antigen-induced airway inflammation in a murine asthma model may provide a basis for evaluation the application of hLF in human allergic inflammation disorders [12, 30].

The strong antibiotic effects of hLF against *Klebsiella pneumoniae* and *Staphylococcus aureus* in mouse models ([31], Chapter 5), provide a basis for studies of the potential of hLF in treatment of patients infected with antibiotic-resistant bacteria such as methicillin-resistant *Staphylococcus aureus* (MRSA) which infections have become an increasing problem in hospitals [32].

Both hLF and bLF, obtained after fractionation of bovine milk whey, can be used in applications of LF in human health care. However, the use of bLF appears restricted to oral applications because of its immunogenicity and the molecule may be inferior to hLF in applications where interactions with

specific receptors are required. Furthermore, bLF is much more susceptible than hLF to proteolysis by digestive proteases such as trypsin ([33], Chapter 7). This higher susceptibility of bLF seems relevant when considering oral applications of lactoferrin where the protein has to survive the harsh environment of the gastrointestinal tract. However, for some oral applications of hLF, it might still be necessary to develop formulations that deliver the protein intact at inflamed sites of the gastrointestinal tract.

The limited availability of human milk and purified hLF have been a major hurdle for (clinical) studies on potential nutraceutical and pharmaceutical applications of hLF. To overcome this limitation, the feasibility of large-scale production of functional recombinant hLF (rhLF) was studied in a wide variety of expression systems such as mammalian cells [34, 35], fungi [36], yeast [37] and transgenic rice [38]. The use of transgenic cows is an attractive alternative for the production of large amounts of rhLF as one cow can produce annually more than 10,000 liters of milk. This thesis emphasizes on the production of rhLF in the milk of transgenic cows.

3. Expression of rhLF in the milk of transgenic cows

The generation of transgenic cows harbouring mammary gland-specific expression vectors based on regulatory elements from the bovine α S1-casein gene and a cDNA encoding for hLF has been described previously [39]. The expression levels of rhLF obtained in milk of transgenic cows, harbouring vectors in which the hLF cDNA was replaced by genomic sequences encoding for a natural occurring hLF variant, are described in Chapter 5. The expression of rhLF in milk of transgenic cows of line 8785 was about 2.5 g/l. Furthermore, expression levels were similar between founder and offspring, among offspring as well as between hormonally- and calving-induced milk and were stable throughout the lactation period of 280 days. The expression of rhLF, even at high levels, did not affect milk-parameters such as total milk output, cell counts, total protein, fat and lactose (Chapter 5, [40]). Thus, a few hundred hLF-transgenic cows will be sufficient to supply thousands of kilograms of rhLF annually.

4. Characterization of rhLF purified from the milk of transgenic cows

Recombinant hLF purified from the milk of transgenic cows appeared saturated with iron for about 8% (Chapter 5 and 9). This low degree of iron-saturation is similar to that of natural hLF and bLF from milk [34, 41] but contrasts to the iron-saturated rhLF preparations obtained from many expression systems including mammalian cells [34, 35], transgenic mice [42] and transgenic rice [38]. Thus rhLF from transgenic cow milk does not require desaturation to obtain preparations able to bind iron.

The methods and results of comparative studies of rhLF and natural hLF from human milk are summarized in Table 1. The results indicate that rhLF and natural hLF are equivalent as to the peptide back-bone, utilization of N-linked glycosylation sites, iron-binding and -release, protein structure, susceptibility towards trypsin and effects in various murine infection models. The only apparent difference resides in the composition of attached carbohydrates. The glycans of rhLF contained N-acetylgalactosamine next to galactose, which is typical for N-linked glycoproteins produced in bovine milk such as bLF [43], and contained less fucose and N-acetylneuraminic acid than in natural hLF (Chapter 5). Based on its monosaccharide composition and susceptibility to N-glycosidases rhLF is predicted to contain oligomannose- and/or hybrid-type glycans next to complex-type whereas only complex-type glycans are found on natural hLF (Chapter 5). Similar differences in N-linked glycosylation have been described previously for antithrombin III from human plasma and the milk of transgenic goats [44]. Differences in N-linked glycosylation between recombinant and natural proteins can be expected since the structures of attached glycans is species, tissue, cell-type and protein specific [45, 46].

The predicted N-linked glycosylation pattern of rhLF was confirmed by further structural analysis of the N-linked glycans, which analysis revealed the presence of at least 17 different carbohydrates (results not shown). Importantly, none of the deduced structures contained immunogenic epitopes such as the α -

Table 1 Comparative analysis of rhLF from transgenic cow milk and natural hLF from human milk

Property	Method	Result	Chapter
Peptide back-bone	DNA sequencing N-terminal protein sequence Deglycosylation and SDS-PAGE	Equivalent	5, 7
Utilization of N-linked glycosylation sites	SDS-PAGE	Equivalent	5, 7
N-linked glycosylation	Monosaccharide analysis Deglycosylation and SDS-PAGE	Complex-, hybrid-/mannose type in rhLF; complex type in natural hLF	5
Iron-binding and -release	Spectroscopy	Equivalent	5
Protein structure of iron-saturated LF	Crystallography	Equivalent	6
Coordination of iron- and carbonate ion in iron-saturated LF	Crystallography	Equivalent	6
Susceptibility to trypsin	Tryptic proteolysis and SDS-PAGE	Equivalent	7
Biological activity	Murine infection models	Equivalent	5

galactosyl epitope [47]. The absence of immunogenic carbohydrates, i.e. structures that may elicit immune responses, in the majority of glycans is particularly important when parenteral applications of rhLF are considered.

Human LF is rapidly cleared from the circulation by binding to negatively charged chondroitin sulphate proteoglycans abundantly present on parenchymal liver cells [48]. The presence of mannose-type glycans and the low degree of sialylation of rhLF might even enhance the molecule’s clearance by the liver through binding to the asialoglycoprotein- and the mannose-receptor [49]. However, pharmacological studies using intravenously injected radiolabeled rhLF and natural hLF showed similar $t_{1/2}$ values and biodistribution in multidrug resistant *S. aureus*-infected mice (Chapter 5) suggesting similar pharmacokinetics for both lactoferrins and that charge-related clearance is the predominant (fastest) clearance pathway. More importantly, intravenously administrated rhLF and natural hLF were equally effective in various murine infection models despite the differences in N-linked glycosylation (Chapter 5).

5. Large scale production of rhLF from transgenic milk

5.1 Purification development

Purification development resulted in procedures which appeared useful for large scale purification of rhLF from bovine milk. The steps for large scale purification of pharmaceutical- and food-grade rhLF (Chapter 5 and 9, respectively) are summarized in Table 2. For both preparations, the transgenic milk is first defatted by centrifugation followed by extraction of the lactoferrin fraction, containing rhLF and bLF, using cation-exchange chromatography on SP Sepharose. The purity of rhLF after SP Sepharose chromatography is considered sufficient, i.e. about 95%, for use in functional foods. To obtain pharmaceutical grade rhLF, the lactoferrin fraction is processed further to remove remaining bovine milk proteins like bLF. Recombinant hLF is separated from bLF by cation-exchange chromatography on MacroPrep High S Support which results in rhLF preparations containing less than 0.1% bLF (Chapter 5). If necessary, further separation of bLF can be achieved by e.g. hydrophobic interaction chromatography [50].

Table 2 Purification of rhLF from transgenic cow milk

Step	Method
1	Defatting of transgenic milk (~2.5 g rhLF/l) by centrifugation
2	Extraction of rhLF by cation-exchange chromatography
3	Concentration and buffer exchange of rhLF by ultra-filtration
4	Bioburden removal by micro-filtration

<i>Pharmaceutical-grade</i>		<i>Food-grade</i>	
5	Viral inactivation by solvent/detergent treatment	5	Freeze-drying of rhLF
6	Purification of rhLF by cation-exchange chromatography	6	Packaging and labelling
7	Concentration of rhLF by ultra-filtration		
8	Viral removal by nano-filtration		
9	Concentration and formulation of rhLF by ultra-filtration		
10	Bioburden removal by micro-filtration		
11	Vialing and labelling		

5.2. Analytical assay development

Various analytical methods have been developed for characterization of purified rhLF. These methods can also be used for release of rhLF batches for nutraceutical or pharmaceutical use and/or to demonstrate batch-to-batch consistency.

The identity and concentration of rhLF in milk of individual cows, milk pools and purified batches can be assessed using specific antibodies against hLF. The generation of ten distinct monoclonal antibodies (mAbs) against hLF is described in Chapter 3. Experiments with proteolytic hLF fragments, rhLF lacking the N-terminal stretch Gly1-Arg2-Arg3-Arg4-Arg5 and the recombinant hLF lobes (Chapter 3, [4]) indicated that five mAbs bound to conformational epitopes residing in the N-lobe, whereas the other five bound to C-lobe conformational epitopes. The mAbs were used in hLF-specific immunoassays (Chapter 3, [4]) and structure-function relationship studies [4]. Other methods developed and/or used in the characterization of rhLF are N-terminal sequencing, monosaccharide composition analysis, iron-binding and release assays (Chapter 5), crystal structure analysis (Chapter 6) and the tryptic susceptibility assay (Chapter 7). The tryptic susceptibility assay revealed a subtle difference, i.e. slightly altered degradation kinetics, between rhLF derived from the Rey cDNA [3] and natural hLF (Chapter 7), whereas other comparative analyses including *in vitro* and *in vivo* antigenicity, iron-binding and release and binding to several ligands did not reveal any difference [42].

Characterization of a biopharmaceutical also includes qualification and quantification of impurities. For rhLF from transgenic bovine milk, these impurities can be derived from the cow (e.g. milk proteins), from the purification process (e.g. viral inactivation chemicals) or relate to rhLF (e.g. degraded molecules). A robust analytical method for determining bovine milk and rhLF-related impurities in purified rhLF is described in Chapter 2. The method, employing cation-exchange chromatography on a Mono S column, discriminates between N-terminally intact hLF and hLF molecules lacking two or three N-terminal residues, lactoferrins from other species (e.g. bLF) as well as homologous and other whey proteins. The Mono S method can also discriminate between the two glycosylation variants of bLF (bLF A and B) which differ in N-linked glycosylation at Asn²⁸¹, a site utilized in bLF A but not in bLF B (Chapter 7). Besides the use of Mono S for detecting bLF, a specific quantitative ELISA has been developed for this molecule (Chapter 5) which allows for the quantification of traces of bLF in pharmaceutical-grade rhLF batches. A specific quantitative ELISA has also been developed for a novel bovine milk protein which co-eluted with rhLF on Mono S (Chapter 8). N-terminal sequence analysis of the novel glycoprotein of Mr 25,000 revealed it to represent the bovine homologue of human neutrophil gelatinase-associated lipocalin (hNGAL) and therefore the molecule was designated bovine neutrophil gelatinase-associated lipocalin (bNGAL).

5.3 Preclinical and clinical development

Studies of possible applications of hLF in human healthcare (see section 2) have become a real option through the availability of large quantities of rhLF from transgenic cow milk. Before starting clinical studies on potential applications, preclinical studies assessing the safety of the proposed medication have to be conducted. The safety of pharmaceutical-grade rhLF has been evaluated in various preclinical studies [51] and in a Phase I clinical study in healthy volunteers which revealed that intravenously administrated rhLF at 60 mg/kg was safe and well tolerated [52]. Similarly, the safety of food-grade rhLF has been evaluated in various preclinical studies [53]. An example of a preclinical study with food-grade rhLF is shown in Chapter 9. Three doses of rhLF (200, 600 and 2000 mg/kg body weight/day) and saline as a control were daily administrated to rats via oral gavage for at least 90 days and a large variety of parameters were monitored. The results revealed no treatment-related, toxicologically significant changes on the basis of which the no observed-adverse-effect level (NOAEL) could be determined on 2000 mg/kg body weight/day.

6. Conclusions

The use of recombinant proteins in human healthcare requires a validated protein production technology, thorough comparison of the physico-chemical and biological characteristics of the recombinant protein with the natural form and extensive preclinical and/or clinical testing to assess the safety and efficacy of the proposed nutraceutical or pharmaceutical. This thesis reports on the use of transgenic cows as protein production technology for recombinant hLF and describes the characterization and safety testing of the purified molecule.

The bovine mammary gland appeared to be an attractive vehicle for producing large amounts of rhLF as constant expression levels, in the gram per liter range, have been obtained without affecting normal milk parameters. Characterization of purified rhLF revealed that the molecule closely matches the structure of natural hLF from human milk except for a difference in glycosylation. The differential glycosylation did not result in difference between rhLF and natural hLF in any of the employed in vitro and in vivo assay systems. Furthermore, rhLF appeared safe and well tolerated in various preclinical studies and in a Phase I clinical study. Taken together, transgenic cows are a valuable platform for the production of rhLF because large quantities of the molecule are expressed, the recombinant molecule displays a structure and function comparable to natural hLF and appears safe for human use. In addition, the results with rhLF illustrate the potential of transgenic cows to produce other recombinant human proteins for therapeutic use.

References

1. Anderson BF, Baker HM, Norris GE, Rice DW & Baker EN (1989) Structure of human lactoferrin: crystallographic structure analysis and refinement at 2.8 Å resolution, *J Mol Biol* **209**, 711-734.
2. Nuijens JH, van Berkel PHC & Schanbacher FL (1996) Structure and biological actions of lactoferrin, *Journal of Mammary Gland Biology and Neoplasia* **1**, 285-295.
3. Rey MW, Woloshuk SL, de Boer HA & Pieper FR (1990) Complete nucleotide sequence of human mammary gland lactoferrin, *Nucleic Acids Res* **18**, 5288.
4. van Berkel PHC, Geerts MEJ, van Veen HA, Mericskay M, de Boer HA & Nuijens JH (1997) The N-terminal stretch Arg2 Arg3, Arg4 and Arg5 of human lactoferrin is essential for binding to heparin, bacterial lipopolysaccharide, human lysozyme and DNA, *Biochem J* **328**, 145-151.
5. Mann DM, Romm E & Migliorini M (1994) Delineation of the glycosaminoglycan-binding site in the human inflammatory response protein lactoferrin, *J Biol Chem* **269**, 23661-23667.
6. Wu HF, Monroe DM & Church FC (1995) Characterization of the glycosaminoglycan-binding region of lactoferrin, *Arch Biochem Biophys* **317**, 85-92.
7. Reiter B, Brock JH & Steel ED (1975) Inhibition of *Eschericia coli* by bovine colostrum and post-colostral milk. II. The bacteriostatic effect of lactoferrin on a serum-susceptible and serum-resistant strain of *E. coli.*, *Immunology* **28**, 83-95.
8. Ellison III RT & Giehl TJ (1991) Killing of gram-negative bacteria by lactoferrin and lysozyme, *J Clin Invest* **88**, 1080-1091.
9. Ellison III RT, Giehl TJ & La FF (1988) Damage of the outer membrane of enteric gram-negative bacteria by lactoferrin and transferrin, *Infect Immun* **56**, 2774-2781.
10. van der Strate BWA, Beljaars L, Molema G, Harmsen MC & Meijer DKF (2001) Antiviral activities of lactoferrin, *Antiviral Research* **52**, 225-239.
11. Aruoma OI & Halliwell B (1987) Superoxide-dependent and ascorbate-dependent formation of hydroxyl radicals from hydrogen peroxide in the presence of iron. Are lactoferrin and transferrin promoters of hydroxyl-radical generation? *Biochem J* **241**, 273-278.
12. Elrod KC, Moore WR, Abraham WM & Tanaka RD (1997) Lactoferrin, a potent tryptase inhibitor, abolishes late-phase airway responses in allergic sheep, *Am J Respir Crit Care Med* **156**, 375-381.

13. Zucali JR, Broxmeyer HE, Levy D & Morse C (1989) Lactoferrin decreases monocyte-induced fibroblast production of myeloid colony-stimulating activity by suppressing monocyte release of interleukin-1, *Blood* **74**, 1531-1536.
14. Lee WJ, Farmer JL, Hilty M & Kim YB (1998) The protective effects of lactoferrin feeding against endotoxin lethal shock in germfree piglets, *Infect Immun* **66**, 1421-1426.
15. Kruzel ML, Harari Y, Mailman D, Actor JK & Zimecki M (2002) Differential effects of prophylactic, concurrent and therapeutic lactoferrin treatment on LPS-induced inflammatory responses in mice, *Clin Exp Immunol* **130**, 25-31.
16. Legrand D, Ellass E, Carpentier M & Mazurier J (2005) Lactoferrin: a modulator of immune and inflammatory responses, *Cell Mol Life Sci* **62**, 2549-2559.
17. Haversen L, Ohlsson BG, Hahn-Zoric M, Hanson LA & Mattsby-Baltzer I (2002) Lactoferrin down-regulates the LPS-induced cytokine production in monocytic cells via NF-kappa B, *Cell Immunol* **220**, 83-95.
18. Dhennin-Duthille I, Masson M, Damiens E, Fillebeen C, Spik G & Mazurier J (2000) Lactoferrin upregulates the expression of CD4 antigen through the stimulation of the mitogen-activated protein kinase in the human lymphoblastic T Jurkat cell line, *J Cell Biochem* **79**, 583-593.
19. Birgens HS, Hansen NE, Karle H & Kristensen LO (1983) Receptor binding of lactoferrin by human monocytes, *Br J Haematol* **54**, 383-391.
20. Mazurier J, Legrand D, Hu WL, Montreuil J & Spik G (1989) Expression of human lactotransferrin receptors in phytohemagglutinin-stimulated human peripheral blood lymphocytes. Isolation of the receptors by antiligand-affinity chromatography, *Eur J Biochem* **179**, 481-487.
21. Ziere GJ, Bijsterbosch MK & van Berkel TJ (1993) Removal of 14 N-terminal amino acids of lactoferrin enhances its affinity for parenchymal liver cells and potentiates the inhibition of beta-very low density lipoprotein binding, *J Biol Chem* **268**, 27069-27075.
22. Suzuki YA, Shin K & Lonnerdal B (2001) Molecular cloning and functional expression of a human intestinal lactoferrin receptor, *Biochemistry* **40**, 15771-15779.
23. Ward PP, Paz E & Conneely OM (2005) Multifunctional roles of lactoferrin: a critical overview, *Cell Mol Life Sci* **62**, 2540-2548.
24. Togawa J, Nagase H, Tanaka K, Inamori M, Nakajima A, Ueno N, Saito T & Sekihara H (2002) Oral administration of lactoferrin reduces colitis in rats via modulation of the immune system and correction of cytokine imbalance, *J Gastroenterol Hepatol* **17**, 1291-1298.
25. Troost FJ, Saris WH & Brummer RJ (2003) Recombinant human lactoferrin ingestion attenuates indomethacin-induced enteropathy in vivo in healthy volunteers, *Eur J Clin Nutr* **57**, 1579-1585.
26. Nichols BL, McKee KS, Henry JF & Putman M (1987) Human lactoferrin stimulates thymidine incorporation into DNA of rat crypt cells, *Pediatr Res* **21**, 563-567.
27. Zhang P, Sawicki V, Lewis A, Hanson L, Nuijens JH & Neville MC (2001) Human lactoferrin in the milk of transgenic mice increases intestinal growth in ten-day-old suckling neonates, *Adv Exp Med Biol* **501**, 107-113.
28. Petschow BW & Talbott RD (1991) Response of bifidobacterium species to growth promoters in human and cow milk, *Pediatr Res* **29**, 208-213.
29. Picard C, Fioramonti J, Francois A, Robinson T, Neant F & Matuchansky C (2005) Review article: bifidobacteria as probiotic agents -- physiological effects and clinical benefits, *Aliment Pharmacol Ther* **22**, 495-512.
30. Kruzel ML, Bacsı A, Choudhury B, Sur S & Boldogh I (2006) Lactoferrin decreases pollen antigen-induced allergic airway inflammation in a murine model of asthma, *Immunology* **119**, 159-166.
31. Nibbering PH, Ravensbergen E, Welling MM, van Berkel LA, van Berkel PHC, Pauwels EKJ & Nuijens JH (2001) Human lactoferrin and peptides derived from its N-terminus are highly effective against infections with antibiotic resistant bacteria, *Infect Immun* **69**, 1469-1476.

32. Rice LB (2006) Antimicrobial resistance in gram-positive bacteria, *Am J Med* **119**, S11-19; discussion S62-70.
33. Brines RD, and Brock, J. H. (1983) The effect of trypsin and chymotrypsin on the in vitro antimicrobial and iron-binding properties of lactoferrin in human milk and bovine colostrum. Unusual resistance of human apolactoferrin to proteolytic digestion., *Biochim Biophys Acta* **759**, 229-235.
34. van Berkel PHC, Geerts MEJ, van Veen HA, Kooiman PM, Pieper F, de Boer HA & Nuijens JH (1995) Glycosylated and unglycosylated human lactoferrins can both bind iron and have identical affinities towards human lysozyme and bacterial lipopolysaccharide, but differ in their susceptibility towards tryptic proteolysis, *Biochem J* **312**, 107-114.
35. Stowell KM, Rado TA, Funk WD & Tweedie JW (1991) Expression of cloned human lactoferrin in baby-hamster kidney cells, *Biochem J* **276**, 349-355.
36. Ward PP, Lo J, Duke M, May GS, Headon DR & Conneely OM (1992) Production of biologically active recombinant human lactoferrin in *Aspergillus oryzae*, *Bio/Technology* **10**, 784-789.
37. Liang Q & Richardson T (1993) Expression and characterization of human lactoferrin in yeast *Saccharomyces cerevisiae*, *J Agric Food Chem* **41**, 1800-1807.
38. Nandi S, Suzuki YA, Huang J, Yalda D, Pham P, Wu L, G. B, Huang N & Lönnerdal B (2002) Expression of human lactoferrin in transgenic rice grains for the application in infant formula, *Plant Science* **163**, 713-722.
39. Krimpenfort P, Rademakers A, Eyestone W, van der Schans A, van der Broek S, Kooiman P, Kootwijk E, Platenburg G, Pieper F, Strijker R & de Boer HA (1991) Generation of transgenic dairy cattle using 'in vitro' embryo production, *Bio/Technology* **9**, 844-847.
40. Hyvonen P, Suojala L, Haaranen J, von Wright A & Pyorala S (2006) Human and bovine lactoferrins in the milk of recombinant human lactoferrin-transgenic dairy cows during lactation, *Biotechnol J* **1**, 410-412.
41. Kawakami H, Shinmoto H, Dosako S & Sogo Y (1987) One-step isolation of lactoferrin using immobilized monoclonal antibodies, *J Dairy Sci* **70**, 752-9.
42. Nuijens JH, van Berkel PH, Geerts ME, Hartevelt PP, de Boer HA, van Veen HA & Pieper FR (1997) Characterization of recombinant human lactoferrin secreted in milk of transgenic mice, *J Biol Chem* **272**, 8802-8807.
43. Van den Nieuwenhof IM, Schiphorst WE, Van Die I & Van den Eijnden DH (1999) Bovine mammary gland UDP-GalNAc:GlcNAc-beta-R beta1-->4-N-acetylgalactosaminyltransferase is glycoprotein hormone nonspecific and shows interaction with alpha-lactalbumin, *Glycobiology* **9**, 115-123.
44. Edmunds T, van Patten SM, Pollock J, Hanson E, Bernasconi R, Higgins E, Manavalan P, Ziomek C, Meade H, McPherson JM & Cole ES (1998) Transgenically produced human antithrombin: structural and functional comparison to human plasma-derived antithrombin, *Blood* **91**, 4561-4571.
45. James DC, Freedman RB, Hoare M, Ogonah Ow, Rooney BC, Larionov OA, Dobrovolsky VN, Lagutin OV & Jenkins N (1995) N-glycosylation of recombinant human interferin-gamma produced in different animal expression systems, *Bio/Technology* **13**, 592-596.
46. Opdenakker G, Rudd PM, Ponting CP & Dwek RA (1993) Concepts and principles of glycobiology, *FASEB J* **7**, 1330-1337.
47. Galili U, Wang L, LaTemple DC & Radic MZ (1999) The natural anti-Gal antibody, *Subcell Biochem* **32**, 79-106.
48. Ziere GJ, Kruijt JK, Bijsterbosch MK & van Berkel TJ (1996) Recognition of lactoferrin and aminopeptidase M-modified lactoferrin by the liver: involvement of proteoglycans and the remnant receptor, *Biochem J* **313**, 289-95.
49. Drickamer K (1991) Clearing up glycoprotein hormones, *Cell* **67**, 1029-1032.

50. Nuijens JH & van Veen HA (1999) Isolation van lactoferrin from milk, *Patent*, US5861491.
51. Koopman J, van Berkel P, Van Veen H, Geerts M, Diefenbach O, Leufkens P, Olson R, Mudumbi R, Walsh G & Nuijens J (1999) Pharmaceutical development of recombinant human lactoferrin, *4th International Conference on Lactoferrin: Structure, Function and Applications*, Sapporo, Japan (May 18-22, 1999), 56.
52. Ziere B, Van Veen H, Koopman J, Van Berkel P & Nuijens J (2001) Safety, tolerability and pharmacokinetics of intravenously administrated recombinant human lactoferrin in humans, *5th International Conference on Lactoferrin: Structure, Function and Applications*, Banff, Alberta Canada (May 4-9, 2001), 43.
53. Ziere B, van Veen H, Vietsch H, Salaheddine M, Nuijens J & de Loos F (2005) Production and safety of recombinant human lactoferrin, expressed in the milk of transgenic cows for nutraceutical applications, *7th International Conference on Lactoferrin: Structure, Function and Applications*, Honolulu, Hawaii USA (October 16-19, 2005), 34.

Samenvatting

1. Inleiding

Humaan lactoferrine (hLF) is een geglycosyleerd, ijzerbindend eiwit dat behoort tot de familie van de transferrines. Het eiwit komt voor in melk, traanvocht, speeksel en in bronchiale en intestinale afscheidingen. Tevens is het aanwezig in de specifieke granula van neutrofiële granulocyten. Humaan LF bestaat uit één keten van 692 aminozuren die in twee homologe lobben gevouwen is (zie figuur 1 van hoofdstuk 1). Elke lob kan één ijzerion binden tezamen met één carbonaation. Voorts bevat het N-terminale deel van het molecuul positief geladen domeinen die negatief geladen liganden zoals heparine en lipopolysaccharide (LPS) kunnen binden.

Uitgebreid in vitro en in vivo onderzoek heeft aangetoond dat hLF antimicrobiële en ontstekingsremmende eigenschappen heeft. Daarnaast is gevonden dat lactoferrine het immuunsysteem kan moduleren. Op basis van deze activiteiten wordt hLF beschouwd als een onderdeel van het aangeboren afweersysteem.

De antimicrobiële activiteiten van hLF berusten op remming van bacteriële groei door het wegvangen van ijzer en het verstoren van de celwandintegriteit. Lactoferrine kan ook virusinfecties remmen. De ontstekingsremmende activiteiten van hLF berusten op de remming van hydroxyradicaalvorming, cytokineproductie en tryptase-activiteit als ook het neutraliseren van LPS. Naast deze ontstekingsremmende eigenschappen kan hLF de afweerreactie van het lichaam bevorderen door het activeren van verscheidene typen witte bloedcellen, zoals monocyt/macrofagen en NK-cellen. De activering van deze immuuncellen door hLF is waarschijnlijk receptor-gemedieerd want receptoren voor hLF zijn gevonden op diverse soorten cellen zoals monocyt, lymfocyt, lever- en intestinale cellen.

2. Toepassingen van humaan lactoferrine in de gezondheidszorg

Door de verscheidenheid aan biologische activiteiten van hLF zijn diverse toepassingen denkbaar in de gezondheidszorg, zowel in de voedingsector als in de farmaceutische sector.

Een interessante toepassing van hLF voor onderzoek is de preventie of de behandeling van aandoeningen aan het maag-darmkanaal, zoals bij patiënten die lijden aan chronische darmontstekingen of patiënten die een chemotherapie ondergaan. Deze patiënten kunnen baat hebben bij de antimicrobiële, de ontstekingsremmende en de immunomodulatoire activiteiten van hLF. Verder is aangetoond dat hLF de groei van darmepitheelcellen stimuleert, probiotische effecten heeft, bijvoorbeeld stimulatie van de groei van *Bifidobacteria*, en mogelijk ook een rol speelt bij de opname van ijzer in de darm. Deze activiteiten van hLF kunnen ook als basis dienen voor de toepassing van het eiwit in klinische voedingen en babyvoedingen.

Een andere, mogelijke toepassing van hLF is het verminderen van symptomen bij patiënten die lijden aan allergische aandoeningen. Dit idee is gebaseerd op studies in diermodellen voor astma waaruit bleek dat hLF de zogenaamde late-fase ontstekingsreacties elimineerde (door remming van tryptase-activiteit) en de vorming van hydroxyradicalen reduceerde.

De sterke antibiotische effecten van hLF tegen *Klebsiella pneumoniae* en *Staphylococcus aureus* in muismodellen (hoofdstuk 5) vormen de basis voor studies naar de potentie van hLF voor behandeling van patiënten die geïnfecteerd zijn met antibiotica-resistente bacteriën waaronder de beruchte methicilline-resistente *Staphylococcus aureus* (MRSA) waarvan de bestrijding in ziekenhuizen momenteel erg moeilijk is.

Zowel hLF als runderlactoferrine (bLF) verkregen uit koemelk kan gebruikt worden voor toepassingen van LF in de gezondheidszorg. Echter, het gebruik van bLF is beperkt tot orale toepassingen omdat afweerreacties door het menselijk lichaam te verwachten zijn bij parenterale toepassingen. Daarnaast is bLF mogelijk inferieur aan hLF in toepassingen waarin interacties met specifieke receptoren in het menselijk lichaam van belang zijn. Bovendien is bLF veel gevoeliger voor het eiwitafbrekende enzym trypsine (hoofdstuk 7). Deze hogere gevoeligheid van bLF voor proteolyse door trypsine in vergelijking met hLF is relevant voor orale toepassingen, omdat trypsine deel uitmaakt van het arsenaal eiwitafbrekende enzymen die aanwezig zijn in het maag-darmkanaal. Voor sommige orale toepassingen van hLF kan het nodig zijn het eiwit te beschermen zodat het intact de maag en de (dunne) darm kan passeren.

De beperkte beschikbaarheid van humane melk heeft de productie van grote hoeveelheden hLF voor (klinische) studies naar potentiële nutraceutische en farmaceutische toepassingen gehinderd. Vanwege deze beperking is de haalbaarheid van productie van recombinant hLF (rhLF) onderzocht in diverse expressiesystemen, zoals zoogdiercellen, schimmels, gisten en planten. Het gebruik van transgene koeien die rhLF tot expressie brengen in de melk, is een aantrekkelijk alternatief voor de genoemde expressiesystemen, omdat één koe meer dan 10.000 liter melk per jaar kan geven en de melkklier een hoge eiwitproductiecapaciteit heeft (circa 300 kg per jaar). In dit proefschrift worden de resultaten beschreven van het onderzoek naar de expressie en karakterisatie van rhLF, geproduceerd in de melk van transgene koeien.

3. Expressie van rhLF in de melk van transgene koeien

In hoofdstuk 5 worden de expressieniveaus van rhLF in de melk van een aantal transgene koeien beschreven. Deze koeien zijn genetische gemodificeerd en daarmee drager geworden van een gen dat gebaseerd is op de regulerende elementen van het melk-specifieke runder- α S1-caseïnen en een genomische DNA-sequentie, coderend voor een natuurlijke hLF-variant. De expressie van rhLF in de melk van transgene koeien van lijn 8785 was ongeveer 2,5 gram per liter. Verder bleek de expressie van rhLF in de melk van de eerste generatie koeien vergelijkbaar te zijn met die van hun nakomelingen. De wijze van melkinductie (kunstmatige inductie met hormonen versus natuurlijke inductie door de geboorte van een kalf) had geen effect op de expressie van rhLF. Daarnaast bleek het expressieniveau stabiel over de gehele lactatieperiode (280 dagen). De expressie van rhLF had geen invloed op de hoeveelheid geproduceerde melk noch op het celgetal en de gehalten aan eiwit, vet en lactose. Evenmin zijn er veranderingen in gezondheid en gedrag van deze dieren waargenomen. Op grond van deze waarnemingen kan geconcludeerd worden dat productie van rhLF door lacterende transgene koeien een realistische manier is om duizenden kilo's rhLF per jaar te produceren ten bate van de gezondheidszorg, met gewoon veevoer als grondstof.

4. Karakterisatie van rhLF

Recombinant hLF dat gezuiverd was uit de melk van transgene koeien, bleek voor 8% verzadigd te zijn met ijzer (hoofdstuk 5 en 9). Dit percentage ijzerverzadiging is vergelijkbaar met dat van natuurlijk hLF en bLF. Het voordeel van een relatief laag percentage ijzerverzadiging is dat rhLF uit transgene koemelk niet gedesatureerd hoeft te worden om preparaten te verkrijgen die ijzer kunnen binden, in tegenstelling tot rhLF uit veel andere expressiesystemen.

In de hoofdstukken van dit proefschrift wordt het onderzoek beschreven dat gedaan is aan de karakterisering van rhLF uit transgene koemelk met natuurlijk hLF uit moedermelk als referentie. De resultaten van de verschillende studies alsmede de gebruikte technieken en referenties naar de hoofdstukken zijn samengevat in tabel 1 van hoofdstuk 10. De resultaten laten zien dat rhLF en natuurlijk hLF hetzelfde zijn met betrekking tot aminozuursequentie, bezetting van N-glycosyleringsplaatsen, ijzersaturatie en -desaturatie, kristalstructuur, gevoeligheid voor proteolyse door

trypsine en antibacteriële activiteit in enkele muismodellen. Het enig gevonden verschil tussen beide moleculen betreft de glycosylering. In vergelijking met het natuurlijke eiwit bevatten de suikerstructuren van rhLF minder fucose, minder sialzuur en naast galactose ook N-acetylgalactosamine. Verder hebben experimenten aangetoond dat rhLF naast een zogenaamde complex-type glycosylering, die alleen op natuurlijk hLF voorkomt, ook suikerstructuren heeft van het oligomannose- en/of van het hybride-type (hoofdstuk 5). Deze bevindingen zijn niet verrassend omdat de glycosylering niet alleen door het eiwit wordt bepaald maar ook door het diersoort, het weefsel en het type cel dat het eiwit produceert.

Het glycosyleringspatroon van rhLF werd bevestigd door verder onderzoek dat de aanwezigheid van tenminste zeventien verschillende suikerstructuren liet zien (resultaten niet gepubliceerd). Niet één van de zeventien suikerstructuren had immunogene epitopen, dat wil zeggen structuren die een afweerreactie kunnen bewerkstelligen, zoals de α -galactosylepitoop waartegen antistoffen circuleren in het menselijk lichaam. De afwezigheid van immunogene epitopen in het overgrote deel van de suikerstructuren is belangrijk bij parenterale toepassingen van rhLF.

Humaan LF wordt snel uit de circulatie geklaard door binding aan negatief geladen chondroïtinesulfaat-proteoglycanen die aanwezig zijn op parenchymale levercellen. De aanwezigheid van oligomannose-type glycosylering en de lage graad van sialylering zouden zelfs de klaring van rhLF door de lever nog kunnen versnellen door binding van het eiwit aan de mannose- en de asialoglycoproteïne-receptor. Echter, farmacologische studies in muismodellen met radioactief gelabeld rhLF en natuurlijk hLF toonden vergelijkbare halfwaardetijden en weefselverdeling aan (hoofdstuk 5) wat suggereert dat beide lactoferrines dezelfde farmacokinetiek hebben en dat lading-gerelateerde klaring de belangrijkste, en snelste, route van klaring van hLF uit de circulatie is. Belangrijker is echter dat, ondanks de verschillen in N-glycosylering, intraveneus toegediend rhLF en natuurlijk hLF even effectief waren in verschillende muismodellen die geïnfecteerd waren met *Klebsiella pneumoniae* en *Staphylococcus aureus* (hoofdstuk 5).

5. Productie van rhLF uit transgene melk op grote schaal

5.1 Ontwikkeling van zuiveringsmethoden voor rhLF

De methoden die ontwikkeld zijn voor het zuiveren van rhLF, zijn ook toepasbaar voor de productie van het eiwit op industriële schaal. De stappen die ontwikkeld zijn om van transgene melk tot gezuiverd rhLF te komen, zijn voor zowel het farmaceutische als het nutraceutische product samengevat in tabel 2 van hoofdstuk 10. Voor beide producten werd de melk eerst ontvet, gevolgd door extractie van de lactoferrinefractie (rhLF en bLF) met behulp van kationenwisselingschromatografie op SP Sepharose. De zuiverheid van rhLF na deze extractie is al voldoende, dat wil zeggen voor ongeveer 95%, voor toepassingen van rhLF in functionele voedingsmiddelen. Verder opwerken van het lactoferrineproduct door de resterende melkeiwitten zoals bLF te verwijderen, heeft geresulteerd in een rhLF-preparaat dat geschikt is voor farmaceutische toepassingen. De scheiding van rhLF en bLF is ook uitgevoerd met behulp van kationenwisselingschromatografie, echter nu op MacroPrep High S Support (MHPS). De chromatografie op MHPS resulteerde in rhLF-preparaten met minder dan 0,1% bLF. Indien nodig is verdere verwijdering van bLF mogelijk met bijvoorbeeld hydrofobe-interactiechromatografie.

5.2 Ontwikkeling van analysemethoden voor rhLF

Verscheidene methoden zijn ontwikkeld voor de karakterisatie van gezuiverd rhLF (tabel 1 van hoofdstuk 10). Deze methoden zijn ook geschikt voor kwaliteitscontrole van geproduceerde rhLF-preparaten.

De identiteit en concentratie van rhLF in de melk van transgene koeien, in tankmelk en in gezuiverde rhLF-preparaten kunnen bepaald worden met specifieke antistoffen tegen hLF. In hoofdstuk 3 is de generatie van tien verschillende monoclonale antistoffen tegen hLF beschreven. Experimenten met proteolytische hLF-fragmenten en de recombinant hLF-lobben (hun karakterisering is beschreven in

hoofdstuk 4) gaven aan dat vijf monoclonale antistoffen gericht waren tegen conformationele epitopen in de N-lob en de andere vijf tegen conformationele epitopen in de C-lob. De monoclonale antistoffen tegen hLF zijn gebruikt voor de ontwikkeling van specifieke immunochemische detectiemethoden (hoofdstuk 3) en in structuur-functieonderzoek van hLF.

Andere methoden, ontwikkeld en/of gebruikt voor karakterisatie van rhLF, zijn N-terminale sequentieanalyse, monosaccharide-compositieanalyse, ijzersaturatie en –desaturatie, kristalstructuur-analyse en gevoeligheid voor proteolyse door trypsine. Met trypsine werd een subtiel verschil gevonden in gevoeligheid voor proteolyse tussen natuurlijk hLF en rhLF afkomstig van een cDNA sequentie, die een cysteïne op aminozuurpositie 404 heeft in plaats van de natuurlijk voorkomende glycine. Uit eerder onderzoek was gebleken dat de glycine⁴⁰⁴→cysteïne-mutatie in hLF geen invloed had op de ijzersaturatie en –desaturatie noch op de binding aan verschillende liganden en de in vitro en in vivo antigeniciteit.

De karakterisatie van eiwitpreparaten voor toepassingen in de gezondheidszorg vereist ook de kwalificatie en kwantificatie van onzuiverheden. Voor rhLF uit transgene koemelk kunnen deze onzuiverheden komen uit de melk (bijvoorbeeld eiwitten), uit het zuiveringsproces (bijvoorbeeld gebruikte chemicaliën) of gerelateerd zijn aan rhLF (bijvoorbeeld afgebroken moleculen). Hoofdstuk 2 beschrijft een robuuste methode voor het bepalen van koemelk- en rhLF-gerelateerde onzuiverheden in rhLF-preparaten. De methode, die bestaat uit kationenwisselingschromatografie op een Mono-S kolom, maakt onderscheid tussen N-terminaal intact hLF en hLF-moleculen die twee of drie N-terminale aminozuren missen. Verder maakt de methode onderscheid tussen hLF en lactoferrines van andere diersoorten (bijvoorbeeld bLF), transferrines en melkeiwitten. De Mono-S methode kan ook onderscheid maken tussen twee glycosyleringsvarianten van bLF, bLF-A en bLF-B, die respectievelijk wel en niet geglycosyleerd zijn op Asn²⁸¹ (hoofdstuk 7). Naast de Mono-S methode voor kwalificatie en kwantificatie van bLF is er een specifieke ELISA ontwikkeld voor dit molecuul (hoofdstuk 5) die speciaal geschikt is voor het bepalen van sporen bLF in farmaceutische rhLF-preparaten. Een specifieke ELISA is ook ontwikkeld voor een niet eerder beschreven koemelkeiwit dat op Mono-S eenzelfde binding en elutie had als hLF (hoofdstuk 8). Met N-terminale sequentieanalyse is aangetoond dat dit eiwit behoort tot de familie van de lipocalines. De lipocalines zijn een functioneel diverse familie van kleine extracellulaire eiwitten die hydrofobe moleculen transporteren. Het nieuw gevonden eiwit werd vernoemd naar de humane homoloog die in eerste instantie, in complex met gelatinase, gevonden werd in neutrofiele granulocyten. Vandaar de naam ‘neutrophil gelatinase-associated lipocalin’ ofwel NGAL.

5.3 Preklinische en klinische ontwikkeling

Nu de productie van grote hoeveelheden van rhLF uit transgene koemelk mogelijk is, kan er gestart worden met onderzoek naar potentiële toepassingen van het eiwit in de gezondheidszorg. Voordat klinische studies naar potentiële toepassingen van start kunnen gaan, moet eerst de veiligheid van het rhLF-product getest worden. Diverse preklinische studies en vervolgens een Fase I klinische studie met gezonde vrijwilligers hebben aangetoond dat een intraveneuze toediening van farmaceutisch rhLF van 60 mg per kg lichaamsgewicht veilig is en goed verdragen wordt. Vergelijkbaar aan het farmaceutische product is de veiligheid van het nutraceutische rhLF-product onderzocht in preklinische studies. In hoofdstuk 9 wordt een preklinische studie met het nutraceutische product beschreven. Drie doseringen van rhLF (200, 600 en 2000 mg/kg lichaamsgewicht/dag) en fysiologische zout als controle werden dagelijks oraal toegediend aan ratten, voor een periode van 90 dagen, en een groot aantal gezondheidsparameters werden gemeten. Het onderzoek resulteerde in de conclusie dat het nutraceutische rhLF-product, in de drie geteste doseringen, veilig was en goed verdragen werd. Op basis van deze conclusie kon de NOAEL (no observed-adverse-effect level) bepaald worden op 2000 mg rhLF per kg lichaamsgewicht per dag.

6. Conclusies

Het toepassen van recombinante eiwitten in de gezondheidszorg vraagt om een gevalideerde productiemethode, een gedetailleerde vergelijking tussen het recombinante eiwit en de natuurlijke vorm en om uitgebreide studies naar de veiligheid en effectiviteit van de voorgestelde toepassing. Het gebruik van transgene koeien als eiwitproductietechnologie voor rhLF en de karakterisatie en veiligheid van het gezuiverde molecuul worden beschreven in dit proefschrift. De transgene koe is een aantrekkelijke en goedkope manier voor productie van grote hoeveelheden rhLF omdat constante expressieniveaus, in de gram per liter hoeveelheden, zijn verkregen in de melk zonder invloed op diverse gezondheidsparameters en normale melkparameters. Karakterisatie van het gezuiverde rhLF toont aan dat het molecuul vrijwel identiek is, in structuur en functie, aan natuurlijk hLF uit moedermelk. Verder blijkt uit de preklinische studies en uit onderzoek bij gezonde vrijwilligers (Fase I klinische studie) dat rhLF veilig is en goed verdragen wordt. Concluderend kan worden gesteld dat de transgene koe een waardevol platform is voor productie van rhLF voor toepassing in de gezondheidszorg. De resultaten met rhLF illustreren tevens het potentieel van transgene koeien voor productie van andere recombinante humane eiwitten voor therapeutische doeleinden.

Harrie van Veen is op 23 februari 1969 te Boskoop geboren. Hij behaalde in 1985 het Mavo-diploma aan de r.k. MAVO Don Bosco te Boskoop, gevolgd door het Havo-diploma in 1987 aan de Samenwerkingsschool voor HAVO-Atheneum te Waddinxveen. Aansluitend volgde hij de studie chemie aan de Leidse Hogeschool te Leiden. Als onderdeel van deze studie liep hij stage bij de vakgroep medische biotechnologie (Universiteit Leiden)/Pharming NV van prof.dr. H.A. de Boer, onder begeleiding van dr. J.H. Nuijens. Het diploma behaalde hij in juli 1991, waarna hij bij Pharming NV in dienst trad, eerst als biochemisch analist en later als wetenschappelijk medewerker. Het in dit proefschrift beschreven onderzoek werd uitgevoerd onder begeleiding van dr. J.H. Nuijens en dr. P.H.C. van Berkel.

