



Universiteit
Leiden
The Netherlands

Excavations at Tell Sabi Abyad, Northern Syria: A Regional Centre on the Assyrian Frontier

Akkermans, P.M.M.G.; Rossmeisl, I.

Citation

Akkermans, P. M. M. G., & Rossmeisl, I. (1990). Excavations at Tell Sabi Abyad, Northern Syria: A Regional Centre on the Assyrian Frontier. *Akkadica*, 66, 13-60. Retrieved from <https://hdl.handle.net/1887/9960>

Version: Not Applicable (or Unknown)

License: [Leiden University Non-exclusive license](#)

Downloaded from: <https://hdl.handle.net/1887/9960>

Note: To cite this publication please use the final published version (if applicable).

AKKADICA

Périodique bimestriel de
la Fondation Assyriologique
Georges Dossin, asbl.

Tweemaandelijks periodiek van
de Assyriologische Stichting
Georges Dossin, vzw.

Directeur L. DE MEYER - Secrétaire de rédaction / Redactiesecretaris D. HOMÈS-FREDERICQ

Secrétariat et siège social:
Musées Royaux d'Art et d'Histoire
Parc du Cinquantenaire 10,
B-1040 Bruxelles (Belgique)
Tél. 02/733.96.10 (entre 9 h. et 10 h.)

Secretariaat en maatschappelijke zetel:
Koninklijke Musea voor Kunst en Geschiedenis,
Jubelpark 10
B-1040 Brussel (België)
Tel. 02/733.96.10 (tussen 9 u. en 10 u.)

TABLE DES MATIERES / INHOUDSTAFEL

P. SANLAVILLE, Pays et paysages du Tigre et de l'Euphrate. Réflexions sur la Mésopotamie antique	1-12
P.M.M.G. AKKERMANS & I. ROSSMEISL, Excavations at Tell Sabi Abyad, Northern Syria : a Regional Centre on the Assyrian Frontier	13-60
LA XXXVI ^e RENCONTRE ASSYRIOLOGIQUE INTERNATIONALE DE XXXVI ^e INTERNATIONALE ASSYRIOLOGISCHE ONTMOETING (Gent - suite / vervolg)	61
RESUMES DES COMMUNICATIONS FAITES PAR DES BELGES SAMENVATTING VAN LEZINGEN GEHOUDEN DOOR BELGEN	61-63
D. HOMÈS-FREDERICQ & M. TANRET, Conspectus Librorum VIII	64-67
PERSONALIA	67
CALENDRIER / KALENDER	68-72

EXCAVATIONS AT TELL SABI ABYAD, NORTHERN SYRIA: A REGIONAL CENTRE ON THE ASSYRIAN FRONTIER

Peter M.M.G. Akkermans * and Inge Rossmeisl

A. INTRODUCTION

The second season of the University of Amsterdam excavation at Tell Sabi Abyad lasted from August 15 till November 4, 1988. Excavation at Tell Sabi Abyad, located in the upper Balikh valley of northern Syria (Fig. 1), was started in spring 1986. This first campaign showed that Sabi Abyad is a major prehistoric settlement, belonging to the later 6th millennium B.C. (Late Neolithic and Early Halaf periods). In addition, however, traces were found of Late Bronze Age occupation, dating in the 13th century B.C. (for a general introduction to the site and an account of the first season's results, see Akkermans 1987a, 1987b; Akkermans, ed., 1989). In 1988, excavation was continued in areas begun during the first season and, additionally, new trenches were opened in the northeastern and southeastern parts of the site as well as on top of the mound. Again, the emphasis was upon the investigation of the prehistoric strata, but Late Bronze Age (henceforth LBA) features were encountered in various squares. Moreover, LBA remains, closely related to those of Tell Sabi Abyad, were also unearthed this season in test trenches laid out at Khirbet esh-Shenef, situated about three kilometres south of Sabi Abyad. This preliminary report is entirely devoted to the LBA remains of Tell Sabi Abyad; the results of the prehistoric investigations will be reported elsewhere. The LBA material from Khirbet esh-Shenef is presented by K. Bartl (in press).

B. THE 1988 EXCAVATIONS

In a stratigraphic context, LBA features were uncovered in squares P11, P12 and Q12 in the southeastern part of Sabi Abyad, and in trenches J10 till J13 on top of the site (see Fig. 2a). Three LBA strata, each defined by architectural features, are distinguished, although not all building levels are equally represented in all areas of excavation. Thus, whereas for example in square P12 three strata are found, in the neighbouring square Q12 only two strata are present (here the topmost building phase is absent). Evidently some areas were used more intensively than others.

* A.E. van Giffen Instituut voor Prae- en Protohistorie (IPP, University of Amsterdam), Singel 453, 1012 WP Amsterdam, the Netherlands.

AKKADICA 66

Both in spatial and functional terms the southeastern areas of excavation and those on the summit of Sabi Abyad are largely different and will therefore be treated here separately. The various building levels are numbered in order of excavation, i.e. from the top to the base, but will be discussed here in order of accumulation, i.e. from the earliest to the latest.

B.1. Excavations in the southeastern area

Stratum 3

The lowest LBA building level in the southeastern area of Sabi Abyad was characterised by a large rectangular mud-brick building, only part of which was uncovered. The larger part of the stratum 3 house can probably be found in square P11 and particularly in square Q11. The latter area awaits excavation but P11 was partly uncovered. Here parts of the walls of the stratum 3 building were found but the associated floor has not yet been reached. The building was oriented NW-SE and built of rather large mud bricks measuring 38/39x39x12 cm. The walls were either 1,5 or 2 bricks (ca. 55-78 cm) wide and simply founded on earth. No foundation works were found. The westernmost wall, partly disturbed by an Islamic burial, was constructed of half-sized bricks, some of them clearly reused (traces of a white plaster were found between several bricks). The building was constructed on the north slope of the southeastern mound of Sabi Abyad. At present this north slope is almost completely hidden from view, but this year's excavation confirmed our earlier impression that Sabi Abyad is built up of various isolated mounds which have merged through time (see Akkermans, ed., 1989:11). The depressions between the various prehistoric mounds were still present in LBA times and used for settlement. Afterwards these depressions were largely filled with LBA erosion material, thus giving the site its present, rather flat and coherent appearance.

So far, the stratum 3 house consists of at least two rooms (A and B), connected by means of a doorway ca. 75 cm wide (Fig. 3). The present evidence suggests that the building was conceived and constructed at a single point in time, since the mud-brick threshold was part of the wall dividing rooms A and B (i.e. it belonged to the lowest layer of bricks of this wall). The floor in both rooms consisted of a whitish and hard-tamped mud layer 5-6 cm thick. A low mud-brick bench seems to be present in front of the eastern wall of room B. The exact dimensions of room B are unknown (part of it still awaits excavation), but the westernmost room (A) turned out to be a small but elongated area measuring ca. 5x2 m. In the northeastern corner of this room, next to the doorway, a small, more or less rectangular bin was found, the wall of which was built of mud bricks of half size. A similar but rounded bin construction was built against the outer

facade of the wall bordering room A to the west.

Interestingly enough, the floors in both rooms were littered with broken but restorable jars and pots as well as a number of complete bowls. Among these vessels a number of conical jar stoppers of clay appeared. In addition, two cuneiform tablets were found on the floor of room A (see the contribution by R. Jas, this volume). In both rooms the finds are concentrated near the doorway (Fig. 3). Most likely these rooms served for storage. No doubt, the finds represent an in-situ context, being the result of a rapid destruction of the building, due either to accident or warfare. No traces of fire were found.

After the collapse of the stratum 3 building occupation must have shifted, since hardly any attempts were made towards rebuilding of this specific area. In view of the present height of some of the walls unearthed (up to 65 cm), the ruins must partially have stood to a considerable height in later LBA times. Only room A seems to have been reused since here traces of a second mud floor were found, sealing the lower in-situ context. From this second floor, and against the northern wall, a pot burial was sunk (B3; see below) as well as a small sherd-plastered pit. It remains unknown whether the former room A was again roofed at this time or whether it was an open, perhaps basin-like area used for various domestic activities. In view of the burial we are inclined to see the latter option as the most likely. This view is also supported by the limited height (one or two bricks) of the southern and western walls formerly bordering room A when contrasted with the other walls, suggesting that these walls were largely levelled after the collapse of the stratum 3 building.

Apart from the house remains, only few other structures are ascribed to LBA stratum 3. In square P12, about one metre south of room A, the remains were found of a circular construction (M) about 155 cm in diameter. This structure was built of mud bricks, each row of bricks corbelling in above the lower one. The structure seems to be accessible through a narrow entrance from the west. The interior was covered with mud but no attempts were made to smoothen the exterior wall face by additional mud plastering, thus yielding a highly irregular exterior wall face. On the outside the bricks were solely covered by a thin white coating (probably gypsum) for decoration and/or consolidation. Most likely this structure served as an oven. Not only was the interior plaster touched by fire, but, moreover, ashes accumulated upon the floor, covered in turn by mud-brick debris and burnt brick fragments. Immediately next to this oven a shallow pit filled with ashy soil was found.

A more or less rectangular hearth or fireplace (L) was found in the southern half of square P12. This hearth measured ca. 75x80 cm and was constructed of mud bricks, partly set on their side, and reinforced, particularly along the base,

AKKADICA 66

by bands of mud. Whereas the exterior gave evidence of a thin white coating, the interior carried a mud plaster which showed traces of firing. In the centre a small pit filled with ashes was present, about 25 cm in diameter, 20 cm deep, and with the sides covered by sherds. Apparently this pit served as the actual place of fire. Next to this pit a shallow bowl was found. Immediately northeast of the hearth a circular sherd-lined pit similar to that found within the hearth was present, although of slightly larger dimensions (ca. 30 cm wide and 20 cm deep) and missing the ashes. When this fireplace finally went out of use for some reason or another, a rounded, "tannur"-like oven was raised immediately above it (stratum 2).

The western part of square P12 was heavily disturbed by pits of various dimensions and depths. Most interesting was a elongated trench along the west balk which perhaps represents a foundation trench of a wall, the mud bricks of which were removed for other purposes (bricks of older buildings were reused as shown by the west wall of room A; see above).

In square P11 a trial trench measuring 4.5x4.5 m was opened in order to track the house remains found in square P12. However, since work in P11 has not yet been completed, little can be said at present. Along the south section, parts of the north wall of room A were exposed; this wall is almost completely hidden in the balk between P11 and P12 (see Fig. 3). Associated with this wall are two other linear features, the nature of which is not yet clear. Although mud bricks were visible at several spots, it is doubtful whether these features represent true walls. In the southeast corner of trench P11 a small oven appeared, ca. 50 cm in diameter and preserved to a height of 47 cm. This oven was built up in coils and had a small ventilation hole at its north base. The oven was constructed upon a circle of baked clay fragments which may represent parts of an earlier but levelled oven. A small but complete jar was found in the area north of the oven, which thus far appears to be an open area.

In square Q12 the area south of the house complex was left open except for the digging of pit F. This rounded pit was about 1,45 m in diameter and over 80 cm deep. It was filled by loose, greenish soil. Interestingly enough, the interior west side of this pit was lined with boulders up to 30 cm in size as well as large, flat bases of pottery (tray fragments?), forming a small platform or step-like construction. This pit may have been used as a latrine, but in the absence of any soil analysis this has to remain speculative.

Stratum 2

Whereas the area formerly occupied by the stratum 3 house was largely left deserted, the space around this building was soon reshaped, thus giving evidence

of a lively habitation (Fig. 4). Oven M remained in use, although some repairs were carried out on its northwestern side. After some time, however, the oven seems to have fallen into disuse and was covered by a mud-brick wall, oriented NE-SE. At this time, the space represented by the excavated areas seems to have been used for open-air domestic activities solely. Permanent structures intended for housing are absent but will undoubtedly be found in the neighbouring and thus far unexcavated squares. Square Q12 is virtually devoid of architectural structures; only a small, rounded oven of the well-known "tannur"-type was found near the west balk. This oven had a diameter of ca. 40 cm and a wall thickness of 2.5 cm. It was preserved to a height of 18 cm. An opening for ventilation, measuring ca. 5.5x10 cm, was present at the base on the south side. The surface around this "tannur", gently sloping towards the southeast, was littered with pottery vessels (11 jars and bowls, the smaller ones still intact) as well as some other objects, viz. two cylindrically-shaped mortars of limestone and other stone, a bronze hook and a bone awl. Among these finds, and in an in-situ context, six beads of dentalia, carnelian and serpentine (?) appeared, as well as a scarab of limestone. These objects were longitudinally pierced and originally formed part of a chain. Associated with this chain a small but unpierced object of black hematite was found, half-round with a flat base, which may have served as a weight. The concomitant occurrence of the chain and the weight suggests that these objects were not simply discarded or lost, but deliberately deposited at this spot. In this respect, it is most interesting that at exactly the same spot but slightly deeper, a cremation burial was found. Perhaps these objects have to be considered as grave goods, intentionally laid down at a time when the burial pit containing the cremation was already largely filled in.

The cremation burial (B1) seems to have been sunk from stratum 2 into the lower levels. Chronologically, this burial is probably related to the pot inhumation (B3) sunk into the ruins of the stratum 3 building; apparently, the outer, uninhabited parts of the settlement at this time were used as burial grounds. In square P12, domestic activity seems to have been concentrated in the southern half of the excavated area. The northern part was probably of marginal importance, with earlier stratum 3 ruins still standing to a considerable height. Most striking is the oven complex surrounding wall J. The latter wall is oriented more or less E-W and built of mud bricks simply founded on earth. Wall J was constructed in two stages (probably divided by a short period of time only) as indicated by the recessed northern wall face. Whereas the western half of wall J is only one brick wide (ca. 38 cm), the additional, eastern part of wall J is widened along the southern face with a half brick (see Fig. 4). Perpendicular to wall J, two walls ran off to the south. Excavations carried out in 1986 in

square P13, however, indicated that these walls were of limited length only and used solely to bound and protect the ovens enclosed. Within the small enclosure, open from the south, at least three rounded "tannurs" are found (two of which were excavated this season, one other was found during the 1986 campaign; more ovens may be present, hidden from view, in the balk between squares P12-P13). The surface surrounding these ovens was covered with light grey ashes. North of wall J again three ovens are present, although here any enclosure is lacking. These ovens, too, represent small rounded or oval "tannurs", built up in coils and about 60 cm in diameter. At this time, the stratum 3 fireplace ~~E~~ went out of use and was replaced by an oval, "tannur"-like oven, raised immediately above it, thereby reusing part of the walls of the lower hearth. This oven measured ca. 80x50 cm.

Northeast of the ovens, a mud-brick platform three bricks wide and four bricks long (ca. 1.20x1.60 m) was present, preserved to a height of one brick only. The outer faces showed traces of a thin white coating. The function of this platform is unknown, but most likely it can be related to the ovens found nearby. West of this platform a wall is found, 2,5 bricks wide (ca. 95 cm), the role of which is enigmatic, too. This wall is fragmentarily preserved and cannot be directly associated with any other feature. The western part of square P12, along the balk, is heavily disturbed by pits of various dimensions.

Stratum 1

The topmost stratum of LBA occupation at Sabi Abyad is so far represented in square P12 by badly preserved wall remains (Wall A) and a pit, the larger part of which can be found in the neighbouring squares O13-O14, excavated in 1986. Traces of wall A appeared about 20 cm underneath the surface of the mound, and consisted of two rows of baked bricks (each brick measuring 30x30x10 cm), lined on both sides by cobbles varying in size between 15 and 30 cm. A pivot stone was found nearby although out of its proper context. The nature and function of this highly eroded wall A is not clear. The area surrounding this wall was characterised by mud-brick fragments and associated debris.

From this stratum a child burial (B2) had been sunk into the lower building level 2.

B.2. Excavations on top of the mound

On top of Sabi Abyad a stepped trench, two metres wide and oriented north-south, was laid out in order to set up a LBA stratigraphy and pottery sequence at the site (trenches J10-J13). As in the southeastern area, three main phases of occupation can be distinguished (strata 1-3).

Stratum 3

The earliest stratum consists of a hard, red surface, ca. 20 cm thick and covering the lower prehistoric levels. Apparently this red layer was intentionally brought up and served to create a flat and stable area for building. In trench J10 excavation arbitrarily stopped at the top of the stratum 3 levels, whereas in trenches J11 and the northern part of J12 so far no architectural features are associated with this surface. In the southern part of J12, however, parts of a wall (N) were found, two bricks wide and four layers high (mud bricks measured 38x38x12 cm) and oriented NE-SW. This wall divides two rooms, on the floors of which a number of complete or restorable vessels were found. These ceramics, apparently still in situ, comprise nipple and button-based goblets, bowls of various dimensions and large jars and pots. At this level excavation arbitrarily stopped, but a small test probe indicated that earlier LBA levels can be found below. At present, it is unclear whether this wall N is built immediately upon the red surface or whether this surface is spatially restricted to that part of the site afterwards used for erecting the "mansion" (see stratum 2).

Excavations were also carried out in trench J13 but here, apart from some wall fragments, no coherent architectural units appeared. Two complete bowls were found. The lowest level reached in trench J13 (at an elevation of 224,60 m) yielded mainly Halafian pottery, suggesting that here prehistoric layers were reached. No traces of the red surface of trenches J11/J12 were found.

Stratum 2

This stratum gave evidence of a huge building, constructed at the highest point of Sabi Abyad and overlooking the settlement and the surrounding fields. As a consequence of the limited size of our trenches, only a minor part of the building has been excavated so far (Fig. 5). The exact dimensions of the building are unknown at present, but, when we combine the excavation evidence with the contour map of Sabi Abyad, it is evident that the building may easily be as large as 50x50 m. The building was oriented NW-SE and constructed in a regular way. Thick mud-brick walls, each being between 2,5 and 2,75 m wide and partly preserved to a height of almost 3 m, ran NW-SE at intervals of 3,5 to 5 m, whereas perpendicular to them walls of the same size ran off to the north and the south. The walls were simply founded on earth and consisted of square mud bricks measuring 38x38x12 cm. Each wall was six or seven bricks wide. The wall faces were covered by a thick mud-plaster (up to 8 cm). At present, three rooms (areas 1-3) have partly been unearthed whereas another area (4) can be interpreted as an outside corridor along the building. Wall J may have bounded this corridor, whereas a small doorway found in wall J may

have given access to it. Despite the considerable height of the various walls no traces of a superstructure were found; the thickness of the various walls, however, suggests that originally an upper storey was present. A well-laid mud floor was encountered in all rooms. Interestingly enough, the northernmost room gave evidence of a violent fire, which blackened the walls and caused the deposition of a thick layer of burnt, almost sintered mud-brick debris and burnt wooden beams, originally perhaps part of the roof construction. Subsequently, a new floor was laid and the walls affected by fire were replastered. No traces of fire or repavement and replastering, however, were noted in the other rooms excavated. This obvious difference in room treatment was also perceptible when, after a period of unknown duration, the building definitely went out of use. Its walls collapsed and the southern rooms 2 and 3 were completely filled with fallen mud bricks and mud-brick fragments. These areas were virtually devoid of finds. In contrast, the northernmost room was filled with loose layers of alternately grey and brown, ashy soil, containing vast numbers of sherds as well as complete vessels. Only along the southern wall base some mud-brick debris was found, which, however, was covered by these grey-brown layers, thus suggesting that these layers were brought in after collapse of the building. The delapidated walls must have formed some kind of basin which seems to have been used as a dump of useless pottery and other debris. Apparently, LBA occupation at Sabi Abyad did not end with the desertion of the main building on top of the site. Another proof of continued settlement is given by the stratum 1 features of trench J12 (see below).

As to the function of the building, we can only speculate for the moment. Its huge circumference as well as the dimensions of the various walls demonstrate without doubt that it was more than a domestic unit. More likely it served as a fortress or mansion of a local ruler. In this respect the building may represent an economic or administrative centre.

An interesting small find came from the second floor of the northernmost room. Here, among a number of large but as yet unidentified animal bones, the sawn, left femur of an elephant (*Elephas maximus*) appeared. Most likely this bone fragment (clearly sawn off the thigh) represents slaughter offal, suggesting that at least in LBA times elephants were part of the natural environment of the Balikh area. Elephant remains were earlier reported from sites in western Syria and the Levant (Alalakh, Ras Shamra, Kamid el-Loz; at the latter site an almost identical sawn femur fragment appeared as at Sabi Abyad; see Bökönyi 1985, Fig. 3) and, most recently, along the Euphrates (Munbaqa; see e.g. Boessneck und von den Driesch 1986:150). From Egyptian sources we know that Thutmose III hunted elephants in the Euphrates valley in 1464 B.C., whereas Assyrian sources

reveal that Ashur-nasirpal II killed 30 elephants in this region around the first half of the 9th century (Zeuner 1963; Smith 1949).

Stratum 1

LBA occupation at Sabi Abyad did not end with the collapse of the huge building. In trench J12 the doorway of wall J was closed by flimsy slabs of mud-brick material. A new wall, one brick wide, was dug in halfway and set against the northern face of the earlier wall J. Against this newly formed broad wall several soil layers, alternately grey and brown in colour, were deposited, covering part of the stratum 2 "mansion". Associated with one of these soil layers is a small "tannur"-like oven, built up in coils and preserved to a height of 20 cm (the larger part of this oven is hidden in the east section). The deliberate dumping of pottery in the northernmost room of the "mansion" also points towards continuing occupation; perhaps this dump is contemporary with the architectural features found in trench J12.

B.3. Some chronological remarks

Both in the southeastern area and on the summit of Sabi Abyad three main phases of occupation are distinguished, each characterized by specific architectural features. Evidently, in the absence of any direct stratigraphic links between both areas of excavation, the succession of strata in the southeastern area cannot simply be put on a par with that on top of the site. LBA settlement at Sabi Abyad does not have any immediate predecessors at the site itself. After a flourishing period of occupation in the 6th millennium B.C., the site was deserted in the beginning of the 5th millennium and left to its fate for millennia to come. Somewhere in the 13th century B.C., as evidenced by the pottery, the small finds and the two cuneiform tablets, the site was reinhabited, but for a short time only. The present evidence suggests that LBA occupation at Sabi Abyad lasted less than a century, i.e. two or three generations. LBA settlement at Sabi Abyad seems to be the result of deliberate planning and organisation, and the settlement as a whole seems to have been conceived and raised within a short period of time. In this respect, at least the earliest strata of occupation in the various areas of excavation can probably be considered as being contemporary. Any temporal differences must be minimal. LBA settlement at Sabi Abyad was concentrated on the western part of the site; the easternmost areas (i.e. east of the Q-line on the grid; see Fig. 2a) must have been of marginal importance. The settlement covered at least an area of one hectare, but when taking the surface evidence into account it may easily be as large as two hectares (particularly the gently sloping southern and western slopes are abundantly covered with LBA sherds; both the 1986 and 1988 excavations have shown that the slopes were occupied).

C. THE LBA BURIALS

During the 1988 campaign at Sabi Abyad four graves, comprising eight individuals, were uncovered which can be definitely ascribed to the LBA, whereas for some other burials a LBA date is suspected. At present, four types of funerary treatment are perceptible at Sabi Abyad:

- pit inhumation
- pot inhumation
- mass interment
- cremation

In square P12, a child younger than two years was interred in a simple, oval pit measuring ca. 25x60 cm and sunk from stratum 1 into earlier layers (thereby destroying part of the stratum 2 wall J). The dead person was laid in a flexed position on the back. The body was oriented NE-SW (atlas to sacrum), with the head towards the southwest, facing north. Associated with this burial was a fragmentarily preserved bone bracelet, probably belonging to the left arm, as well as a string of beads around the neck. This necklace consisted of 35 beads, made of limestone, shell and an as yet unidentified kind of greenish stone. So far, this child inhumation is the only individual pit burial at Sabi Abyad which can be definitely ascribed to the LBA. Related burials, with the dead in a flexed position on the side, were found in 1986 on the northeastern mound of Sabi Abyad (see Akkermans 1987b:33; Geerlink 1989:295-99), whereas during the 1988 season six more graves appeared in this area. In the absence of any grave goods, however, the dating of these burials remains enigmatic. A LBA date has been suggested for these graves (*ibid.*), a view which is supported by the newly found child burial in square P12.

The second type of LBA burial treatment, the pot inhumation, is hitherto represented by one example only (B3 in square P12; see Figs. 15-16). This grave belongs to stratum 2 but, interestingly enough, was dug along the wall of room A, which was part of the lower, stratum 3 house in this area. It remains doubtful whether this pot burial represents a true intramural inhumation or should be considered as a grave constructed in a deserted part of the settlement; at present, we are inclined towards the latter option.

Burial B3 consisted of a pit, measuring about 70x50 cm, with a depth of 90 cm. In this pit a large burial vessel was laid on its side. In order to inter the dead person, the upper side of the burial urn had been deliberately smashed; after interment, the fragments of the urn as well as some fragments of another, incompletely preserved vessel were used to close the burial pot. The feet, which apparently stuck out, were supported by means of a small bowl placed upside

down. The burial pot contained the well-preserved remains of a child two or three years old. The body was laid on the back in a loosely flexed position, and oriented NW-SE, with the head towards the north, facing southeast. The legs were tightly contracted, the right leg resting against the left one. The arms were contracted, too, the lower arms resting upon the abdomen. Two pathologies were detected, viz. porotic hyperostosis and rickets. The latter was indicated by the legs which were bent more than usual, probably resulting from a vitamin D deficiency (which causes softening of the bones). Severe porotic hyperostosis was found on both parietals and the frontal bone. In these places the bone had become thickened and porous as a result of an expansion of the diploe bone of the skull. This expansion is caused by an increased red bloodcell production due to an iron deficiency anemia (Liesbeth Smits, pers. comm.). The dead child was well equipped with ornaments which most likely should not be considered as true funerary gifts but as personal belongings. The wrist of the right arm carried two bronze bracelets, whereas the legs were each provided with two bronze anklets. Around the neck, the child was wearing two strings of beads and pendants. One of these necklaces consisted of over 100 small, black (76), white (35) and red (2) disc-like beads of stone and shell. These beads were strung according to colour, i.e. all black ones were grouped, followed by a row of white beads; the latter were interwoven with the two red ones. The other necklace was wholly different and consisted of 13 perforated shells of varying size, two elongated beads of rock crystal, one rounded bead of unbaked clay, 1 bead of greyish stone and one red polished bead of stone (marble?). Finally, behind the child's head five flat squares of shell were found. These objects were 1,5-2 cm long and wide, and ca. 2 mm thick. All were perforated. Most likely these objects served as hair ornaments. Intriguing was the appearance of a small, rectangular piece of ochre upon the abdomen. This crumbly material cannot have had an ornamental function, and most likely was given to the dead child at interment.

In square R13, immediately underneath the tell surface, a mass burial was found, containing five individuals (Fig. 13b). The skeletal remains were in a bad state of preservation. The grave occupants were between 23 and 40 years old at the moment of death, and four of them were identified as male. The fifth could not be definitely ascribed to either sex, although the robust state of some of the bones suggests that this individual was male, too. The dead were buried in a large pit, about 1.80 m in diameter. Interestingly enough, this pit was originally not intended for burial; it was dug to serve other purposes and only at a time when it was already largely filled with soil and occupational debris it was chosen for interment. All individuals were oriented NW-SE, with the heads either towards the north (three individuals) or the south (two individuals).

Three of the dead lay in a contracted position, either on the back (one person) or on the side (two persons), the two others lay on the back in a supine position. The skeletal remains of the three individuals in the centre of the pit were partly overlapping or intermingled, one of the dead even lying on top of another. The orientation and position of the bones show that the dead were all buried at the same time, and, consequently, must have died more or less at the same moment. Climatic conditions in the Near East lead to a rapid decomposition of the corpse, thus necessitating interment within a short period after occurrence of death. The careless positioning of the dead as well as the nature of the burial pit suggest a hasty interment without any appropriate treatment or ritual discourse. No grave goods were found except a cylinder seal of stone, lying at the waist of the middle individual and originally perhaps being part of a belt or the like (Fig. 17a-b; see the section on small finds). The nature of this mass interment is not yet clear. The apparent absence of any ritual discourse, the choice of grave location, the careless positioning of the dead as well as the fact that we are dealing with males within a specific age group only, suggests that this mass burial is of an exceptional character, denying any tradition-bound rules or demands of burial behaviour. Although we may be dealing here with hastily buried victims of plague or famine, it seems more likely that the dead were victims of warfare or perhaps execution.

The last type of burial treatment so far recognized at Sabi Abyad is represented by the cremation found in square Q12. In an oval pit, having a diameter of about 75 cm and a depth of 60 cm and dug in from stratum 2, a rather small jar (Fig. 9, no. 20) was buried, containing the partly burnt remains of a female adult aged between 23-40 years. The burial vessel was in a slightly tilted position, with the opening towards the west. Evidently this cremation grave represents a secondary burial; the firing of the corpse, however, may have been performed at the same place since the upper part of the burial pit was red-burnt. Immediately next to the burial jar a ram skull was placed, which must still have been in the flesh when buried (as shown by the order and preservation of the bones). This skull was placed at a slightly higher elevation than the burial urn and outside the pit proper into which the vessel had been laid (thus giving the impression of being laid upon a kind of "platform" in the pit). Apart from the ram skull, no grave goods are directly associated with this cremation burial. However, at a slightly higher elevation, and immediately above the burial, a chain consisting of six beads and a scarab were found, as well as a weight of hematite. Perhaps these objects were intended as burial gifts, laid down when the grave was filled with soil. Moreover, a considerable number of pottery vessels was found on the surface from which the burial was sunk (cf. Fig. 4), but whether these

vessels are to be associated with the cremation is unknown. Whereas simple pit inhumations, particularly of children, may have taken place within family or close kin circles, the act of cremation of older members of a community may have attracted a wider public. It is to be recalled that the ram skull found in the grave must still have been in the flesh when buried; perhaps this animal was intentionally slaughtered for this occasion. In this sense, the vessels on the surface around the burial may result from ritual "feasting" or the like, and may afterwards have been discarded on the spot (for a similar suggestion on mid-2nd millennium burials from Terqa, see Buccellati and Kelly-Buccellati 1977:30).

The few LBA burials uncovered thus far at Sabi Abyad indicate an interesting variability in the treatment of the dead. Apart from the mass interment, which is no doubt of an exceptional nature, three types of formal burial behaviour are recognised. A true cemetery may have existed in the close vicinity of the site, but at least some of the dead, both children and adults, were buried within or at the margins of the settlement. What reasons underlie the choice of burial treatment is not yet clear. Simple pit graves and pot inhumations have a long history and are found throughout the second millennium (and before) in Mesopotamia and Syria. Cremation burials, however, hardly appear in earlier times in these regions. Whereas cremations are commonly found in second millennium Anatolia, in Syria cremations, although already present at the end of the second millennium, seem to constitute a mainly first millennium (Iron Age) feature of burial treatment. In view of the cemeteries at e.g. Hama or Carchemish, cremations are commonly associated with Hittite presence or influence (see Moorey 1980:6), but in the east, e.g. at Assur or Babylon, we find these graves in Neo-Assyrian times (Haller 1954:52ff; Reuther 1926:189).

D. THE LBA POTTERY

Thousands of sherds as well as a number of complete vessels were recovered from the LBA exposures at Sabi Abyad. About one third of the pottery sample can be considered to be diagnostic, i.e. these sherds represented either rims or bases. Decorated body fragments are virtually absent with the exception of some late Khabur painted sherds and two gray-polished Nuzi sherds with incised concentric circles inlaid with white paste. A detailed analysis of the LBA pottery is under way (Rossmeis, in preparation); here only some preliminary results are presented on the basis of 80 complete or reconstructible (from rim to base) vessels found on floors, in burials or in secondary deposits. Thus, 32 vessels were collected from the floors of the stratum 3 architecture in squares P12, Q12 and J12 (to avoid repetition, a selected sample is shown in Figs. 7-9, nos. 1-19). Two burial jars come from stratum 2 in squares P12 (Fig. 14a) and Q12 (Fig. 9, no. 20). The

other illustrated vessels were found in secondary contexts such as the room fill or "dump" in room 1 of trench J10 (Fig. 9, nos. 23-31; Fig. 10, nos. 32-42; Fig. 11, nos. 43-49).

Although the architectural features in the various areas and strata of excavation show a considerable variability, the recovered pottery is highly uniform, both in shape and technique of manufacture. The spectrum of shapes is restricted and points towards standardisation. Moreover, the various kinds of ceramics do not seem to be limited in distribution to a specific area or stratum.

Shape

The majority of the complete vessels are bowls varying in size from small and shallow to large and deep. In shape, however, these bowls show a considerable homogeneity. Commonly the rim is plain and thickened outwards. Only two vessels showed inward-thickened lips (Fig. 7, no. 9 and Fig. 10, no. 40). Most of the bowls are slightly carinated; only three bowls have a more or less straight wall (Fig. 7, nos. 8-9; Fig. 10, no. 40). Bases show but little variation, being either flat (Fig. 7, no. 10; Fig. 9, nos. 26 and 29; Fig. 10, no. 40) or showing concave disks (Fig. 7, nos. 1-2, 4). Occasionally some slightly developed ring bases occur (Fig. 10, nos. 36, 38 and 41).

Jars, all of rather large size, are less abundant. Various kinds of rims occur, viz. ribbon rims (Fig. 8, nos. 12, 15), everted and hardly outward-thickened rims (Fig. 8, no. 11; Fig. 9, no. 17) and flat, outward-thickened rims (Fig. 9, no. 20). Usually jars seem to have ring bases. Associated with the tall but narrow ribbon-rim jars a number of unbaked clay stoppers, conical in shape with a flat top, was found on the floors of the rooms of the stratum 3 building in square P12.

Within the limited sample studied, only four pots were present. These vessels have flat and more or less hammer-like rims, all turning obliquely inwards (Fig. 8, nos. 13-14; Fig. 11, nos. 48-49).

Goblets are present in various shapes (Fig. 9, nos. 18-19, 22; Fig. 11, nos. 43-44). Five complete ones were found, all having simple, plain rims and either nipple or button bases. These kinds of bases, commonly occurring at Sabi Abyad, seem to be limited in distribution to goblets. Goblets with the same overall shape may have different bases (cf. Fig. 11, nos. 43-44; whereas no. 43 has a ring or button-like base, no. 44 has a true nipple base).

So far, only three complete potstands were found, showing various shapes (Fig. 11, nos. 45-47). Whereas no. 45 has a truncated conical shape with prominently overhanging rims, nos. 46-47 have more or less straight walls with flat and outward-thickened rims.

Technological aspects

The pottery is wheelmade and mainly tempered by a combined use of either plant and lime or plant and fine sand. Vegetable inclusions together with both lime and sand are less common, whereas purely mineral-tempered vessels are rare. Most of the pottery is well-fired (dark cores, indicating incomplete oxidation, are largely absent). Interestingly enough, many of the bowls at Sabi Abyad show cracks or bursts, particularly around the interior base. Most likely these deficiencies resulted from uneven drying and water expansion during firing. It is suggested that, at least in the case of these bowls, manufacture was hasty and careless, but, moreover, that firing conditions were ill-controlled. The latter is also indicated by a number of warped bowls. Apparently we are dealing here with a rapidly and mass-produced kind of pottery, having but little intrinsic value. The fact that most intact vessels at Sabi Abyad represent this kind of bowls suggests that these bowls had a short effective lifetime and were easily discarded. In view of the cracks it seems that these bowls cannot have contained liquids but must have had a dry content.

All ceramics were wet-smoothed. Traces of slip or burnish were not found within the studied sample but both kinds of surface treatment do actually occur at Sabi Abyad (during the 1986 season of excavation a small number of slipped and occasionally burnished goblets was found; see Rossmesl 1989). Decoration is largely absent. In stratum 3 of square Q12 a carefully made pot with ridges was found (Fig. 8, no. 14). Two small ridges are present just underneath the rim whereas nearly halfway the body two larger ridges with grooves are found. A cremation jar (Fig. 9, no. 20) showed one groove high on the shoulder. The jar containing the child inhumation (B3) in square P12 has a horizontally incised band on the shoulder. Moreover, the zone between this incision and the rim is painted black. On the body below the incision a large rectangle was painted, perhaps having a symbolic signification within a religious or ideological framework (Fig. 14, no. 50).

Comparisons

In the Balikh valley, the closest parallels for the LBA pottery of Sabi Abyad were found during excavations at nearby Tell Hammam et-Turkman and Khirbet esh-Shenef. At the former site, the pottery ascribed to period VIII B (Smit 1988) shows some close resemblance to our ceramics, particularly with respect to the bowls. Khirbet esh-Shenef, sounded in 1988 within the scope of the archaeological work at Sabi Abyad, seems to represent an extremely small LBA settlement (probably containing only one or two houses), the pottery of which is virtually identical to that of Sabi Abyad (see Bartl, in press).

Further east, LBA II pottery is found at Tell Fakhariyah (Hrouda 1961), but, apart from the nipple-base goblets, these ceramics seem to be largely different from those of Sabi Abyad (especially in the shape of the pots and jars). Most interesting, however, are the comparisons with Tell Sheikh Hamad on the lower Khabur. This site, identified by textual evidence as the Assyrian governor's seat of Dur-katlimmu and dated, by the same texts, in the second half of the 13th century B.C., yielded a pottery assemblage virtually identical to that of Sabi Abyad (see Pfälzner 1986). All published shapes of Sheikh Hamad are paralleled by examples from Sabi Abyad. Only the materials used for tempering show some difference: whereas at Sheikh Hamad there seems to be a considerable number of solely plant-tempered ceramics, at Sabi Abyad temper materials mainly consist of vegetable inclusions in combination with mineral particles. Pfälzner (1986) has also published some of the so-called Middle Assyrian pottery found on the surface of tells Umm 'Aqrebe, Agaga and Ta'ban, and in excavation at Tell Barri, all of which show striking parallels to the ceramics of Sabi Abyad. Other comparisons, particularly regarding the nipple-base goblets, are found at sites like Tell Billa (Speiser 1933) and Mohammad Arab (Roaf 1983).

In the regions west of the Balikh valley, comparisons are hard to find at present, due to incomplete excavation reports (hardly anything of the pottery of, e.g., Tell Fray or Emar/Meskene, both dating in the 13th century B.C., has been published) and to the poor state of occupation at some sites (e.g. late 13th-century Munbaqa). It would be most interesting to learn more about the ceramics of Hittite-ruled western Syria. At Tell Fray, Middle Assyrian texts were found, suggesting relations to the east, whereas some connections with the Hittites are indicated by the find of a bulla impression, belonging to Hattusilis III and Puduhepa (Archi 1980). In the case of Munbaqa, the small finds (particularly the cylinder seals) point more towards western Syria, e.g. Alalakh II.

In view of the close resemblance to Sheikh Hamad, it seems that LBA occupation at Sabi Abyad largely dates from the second half of the 13th century. The small finds and the tablets found at Sabi Abyad confirm this view. Sabi Abyad, and probably the Balikh valley as a whole, seems to have been closely oriented towards eastern Syria and northern Iraq, dominated at this time by the Assyrians. Whereas at the eastern sites the presence of Assyrians is confirmed by textual evidence, it remains to be investigated whether this also holds for the Balikh region. However, on the basis of the two cuneiform tablets from Sabi Abyad, Jas (this volume) concludes that Assyrians were actually present at our site.

E. THE OTHER SMALL LBA FINDS

So far, only few small finds have come from the LBA strata of Sabi Abyad. Two cuneiform tablets were found on the floor of room A in square P12, whereas a third one, unfortunately heavily worn, appeared in the topsoil of the northeastern mound (see the contribution by R.Jas, this volume). Most of the finds, however, appeared in burials. The ornaments found in the various graves have already been mentioned before; here only some of these objects will be discussed in greater detail.

In association with a necklace, and probably as part of a burial gift (ascribed to the cremation burial in square Q12), a longitudinally perforated scarab was found, made of a soft white stone (Fig. 16, no. 59). The latter is interesting since scarabs are usually made of blue or green-glazed faience. Although found together with a necklace, the common way to wear a scarab is in a metal ring-setting. However, no traces of metal were discovered and perhaps this scarab was actually part of the necklace. The seal on the base shows a bull or lion and an enigmatic kind of tree. Two signs, perhaps representing the Egyptian hieroglyph for gold, are placed above the animal. On the basis of the calligraphy of the seal, this scarab clearly belongs to the LBA period. Most likely, it was locally made.

In the mass burial of square R13, and near the pelvis of a male, a cylinder seal was found (Fig. 17). This seal, probably made of serpentine, was longitudinally pierced and had a length of 42 mm. Execution of the seal was rather rough. It is not completely round, thus making it difficult to prepare a nice impression. Along one edge it is slightly damaged. Two main figures are visible: a male person with a shield and dagger in his hands confronts a bull kneeling on a mountain. The male person has all the hallmarks of a Hittite, holding in his right hand an eight-shaped shield (normally a shield is held on the left arm). Such shields are known from the Egyptian Qadesh reliefs of, e.g., Abu Simbel and the Ramesseum (Wreszinsky 1933, Pls. 168 and 92-99; Desroches-Noblecourt et al. 1971, Pl. IV), and recently a mould of an eight-shaped shield was excavated at Qantir in the Nile delta (Leclant 1985, 1986). The male person wears a short skirt with a broad belt, from which two tassels are falling down. His hairdress, on the other hand, has parallels in the Middle Assyrian glyptic. The bull is well-shaped with pronounced muscles on the flanks and in his neck. He is kneeling on a mountain in a rather static attitude. Since the hairdress (with a cap?) of the male person is in Middle Assyrian style, and the shield and the skirt are in Hittite style, it seems that this cylinder seal is of local derivation. On Middle Assyrian seals the skirt has the same length but the tassels are much longer (Moortgat 1941-42, Abb. 57ff). Bulls are rarely found on

Middle Assyrian seals and, when present, they are more vividly executed (*ibid.*, Abb. 68). The iconological meaning of the scene itself is more puzzling. A bull on a mountain might stand for the Hittite thunder god Teshub; however, no sign or attribute points in this direction. Moreover, it is most unlikely that a Hittite warrior is attacking his main god! Rather, one is reminded of the killing of the bull of heaven by the thunder god, a theme that occurs on Mesopotamian seals of the Early Bronze Age (e.g. British Museum seal 89089, see Boehmer 1965, Fig. 369) and, occasionally, on Syrian seals of the Middle Bronze Age (e.g. Parrot 1961:6, Fig. 8; Strommenger 1962, Fig. 179c). It symbolizes the divine intervention which puts an end to drought and causes the rain to fall (Frankfort 1939:126-27). The mountain is sometimes found on Hittite seals but appears more frequently on Middle Assyrian seals. Sometimes a tree is growing on such a mountain or animals are connected with it. Such a scene seems to have a more profane character. Perhaps the person designing our seal intermingled various themes from both the Hittite and Assyrian worlds.

An *impression* of a cylinder seal was found on one of the short sides of a cuneiform tablet from Sabi Abyad (SAB 88-T1; Fig. 16, no. 60). Only part of the seal was rolled, the impression having a height of only 18 mm. On the left, the head of a male can be seen. He wears a rather tall cap with two horizontal folds. The upper part of the cap is damaged by script signs as well as a horizontal line bounding the area of inscription; apparently the impression was made before the tablet was inscribed. A lock of hair falls out of his headdress in his neck. One of the lower arms is visible, stretched in front of the person. It is unclear whether the person is holding something in his hand. Under his hand, slightly to the right, the upper part of a star is perceptible. In the right upper corner part of a leg of what must be a lion is recognizable. This seal impression has excellent parallels with the Middle Assyrian seals. The same headdress of the male appears on a cylinder seal in the Metropolitan Museum in New York (Moortgat 1941-42, Abb. 9). The star is nearly omnipresent on Middle Assyrian seals (*ibid.*, Abb. 5, 8, 16, 39, 42). These seals often carry lions, too, the legs of which resemble our impression. Finally, the technique of drilling to indicate the claws is also paralleled by Middle Assyrian seals (*ibid.*, Abb. 4, 25, 30, 33). It is not clear whether the leg on our seal represents the fore or hind legs of the lion. Male figures on this kind of seals can stand both before or behind an animal (compare *ibid.*, Abb. 7-8 and 9). Most likely, this seal impression from Sabi Abyad, on the basis of the above-mentioned characteristics, can be dated in the second half of the 13th century, i.e. the reigns of Shalmaneser I or Tukulti-ninurta I.

The only example thus far of a human figurine (unfortunately fragmentarily preserved) was found in the debris layers or "dump" of room I in

trench J10. This male head is roughly shaped, the features simply being indicated by incisions or impressions (Fig. 16, no. 56). Thus, two small horizontal, incised lines represent the mouth and nose, whereas some other incisions indicate a cap and beard. The eyes are formed by two tiny impressions.

Metal objects are rare. Apart from the bronze bracelet and anklets found in burial B3 (Fig. 14, no. 54), a long bronze needle (Fig. 16, no. 58) was found in square P12, stratum 2, whereas a bronze pin with a curled-in top appeared in room 1 of trench J10 (Fig. 16, no. 57). It is remarkable that at a LBA site like Sabi Abyad only so few bronze objects appear. The only other bronze object found so far, stems from the 1986 excavation and takes the shape of an axe (Akkermans 1989, Fig. VIII.4., no.20).

F. DISCUSSION

During the 15th and early 14th centuries B.C., northern Syria was ruled by the Mitannian kings. The Balikh valley, too, was probably part of Mitanni, as indicated by the excavations at Tell Jidle and Ibn esh-Shehab (Mallowan 1946) and, more recently, at Tell Hammam et-Turkman (Van Loon 1985). At Jidle, level 2, traces were found of badly preserved domestic architecture, associated with so-called Nuzi ware. Similar features were uncovered at Ibn esh-Shehab. Mallowan (1946:132) suggested a date of ca. 1450- 1350 B.C. for these levels. At Tell Hammam et-Turkman, two phases of LBA occupation are recognised, termed Hammam VIII A and VIII B, but it is only the lower phase (VIII A) which can be related to Mallowan's findings. Hammam VIII A is characterised by a large palace or mansion, which, to judge by the scarce pottery found in it, can be dated in the Mitanni period (Van Loon 1985:26).

Around the middle of the 14th century Hittite expansion towards the east ultimately resulted in the fall of the Mitanni kingdom. In the Balikh valley, the collapse of Mitanni can perhaps be associated with the desertion of numerous settlements which seems to have taken place around this time. At present, we have no evidence that the abandonment of settlements is due to direct acts of violence or deliberate destruction; sites seem to have been simply deserted and left to their fate. Mallowan (1946:132) suggests that the scarcity of finds both at Jidle and Ibn esh-Shehab was due to the fact that the inhabitants collected their possessions and subsequently left. The same seems to hold true for Tell Hammam et-Turkman. Here the large residence was emptied of its contents and abandoned, but, to infer from the doorways blocked by mud bricks, apparently a return was envisaged. Restoration of power, however, did not take place and eventually the building fell into ruin. Whether Tell Hammam et-Turkman as a whole was deserted at this time is unknown, but at least a period of local erosion

of as yet unknown duration set in.

Evidently, the desertion of numerous settlements at the end of the 14th century is not an isolated phenomenon, but must have affected local society at all levels. The abandonment of the palace at Tell Hammam et-Turkman suggests that an end came to local institutions of power and authority, whereas economic relations, both intra- and intersite, must have been seriously disturbed, too. Simply speaking, it seems that fields were left untilled, trade centres disappeared and manufacturing centres collapsed. Necessarily the desertion of sites involved a movement of people, who must have either left the Balikh region to settle elsewhere or, perhaps more likely, returned to a nomadic way of life.

The later part of the LBA is, in a stratigraphic context, represented by Sabi Abyad and phase VIII B at Tell Hammam et-Turkman, and, in chronological terms, here equated with the 13th century B.C. There seems to be little doubt that LBA occupation at Sabi Abyad in its entirety dates to this period. At present, only few sites can be ascribed to this 13th century. A preliminary analysis of survey evidence suggests that, whereas at least 32 sites belong to the earlier part of the LBA (= Hammam VIII A), only 14 sites can be placed in its later stage (= Hammam VIII B and Sabi Abyad). We thus see a dramatic reduction of settlement density, accompanied by a shift in settlement location. Particularly the lower Balikh at this time seems to be virtually devoid of permanent settlement, but also in the upper Balikh region settlement was limited to a few sites only. Whereas in earlier, Hammam VIII A times also the undulating plain away from the river was inhabited, occupation now is restricted to the immediate surroundings of the Balikh and its major wadis. Moreover, most of the sites ascribed to the later LBA, such as Sabi Abyad, are newly founded.

In broad terms, the general picture seems to be one of discontinuity between the earlier, Hammam VIII A period and the later, Hammam VIII B/Sabi Abyad period. After a period of major socio-political disturbance and economic collapse, social conditions seem to stabilise again in the 13th century, thus enabling, although on a limited scale, a renewed development of settlement and society. Sabi Abyad seems to have played an important role in this new constellation.

The major features of the LBA settlement at Sabi Abyad can be summarised as follows:

- LBA occupation suddenly appears at Sabi Abyad, without having any immediate predecessors at the site. Thus the inhabitants of Sabi Abyad necessarily came from elsewhere, either from somewhere within the valley itself or from outside the area.
- LBA occupation at Sabi Abyad was of relatively short duration, and

probably lasted less than a century, i.e. two or three generations.

- Sabi Abyad seems to represent an economic and administrative-political centre, as shown by the huge building on top of the site, the presence of storage facilities, and the presence of administrative records. Sabi Abyad thus was more than a simple farming village or the like. This is also indicated by a rather rich burial like the child interment (B3) found in square P12, which may point towards an accumulation of wealth at Sabi Abyad.
- The establishment of this political-economic centre was performed within a short period of time; apparently, the newcomers at Sabi Abyad were invested with power.
- Sabi Abyad seems not to have been defended by means of military structures, if we leave the large building on top of the tell out of consideration. Apparently no direct threat was present, either because of an equilibrium in power in the region or because of protection by a more powerful institution.

The rise of Sabi Abyad to the status of a political- economic centre seems to have taken place at the expense of nearby Tell Hammam et-Turkman. At the latter site, the ruins of the period VIII A palace were covered, after a period of erosion, by a hard-packed loam layer and reoccupied. Only flimsy traces of domestic architecture are thus far associated with this second LBA phase, termed VIII B, at Tell Hammam et-Turkman. The present evidence suggests that Tell Hammam et-Turkman, for millennia the political and economic centre in this part of the Balikh valley, lost its leading position and was reduced to a settlement of secondary importance during the later stages of the LBA period. In view of the huge dimensions of Tell Hammam et- Turkman and the limited scale of the excavations carried out, it can be argued that the present evidence gives a distorted picture of 13th century occupation at the site, or, stated in other words, that Tell Hammam et-Turkman remained the major centre of occupation in the region. In that case, however, it seems unlikely that at Sabi Abyad, at a distance of only 3.5 km east of Tell Hammam et- Turkman, a contemporary, and no doubt competing, economic- political centre was founded. In our view, Sabi Abyad took over the leading role of Tell Hammam et-Turkman in the 13th century, the latter settlement now being dependent in economic and political respect upon the former. Apart from Tell Hammam et-Turkman, three very small later LBA sites, probably representing single farmsteads, are found in the immediate surroundings of Sabi Abyad, one of which, Khirbet esh-Shenef, was sounded during the 1988 campaign (see Bartl, in press).

Although at a more general level the function of Sabi Abyad is clear (viz.

as an economic-administrative centre), its exact nature is far from obvious. How to explain the sudden rise and fall of Sabi Abyad? And, perhaps even more important, how to interpret the role of Sabi Abyad, and consequently that of the Balikh valley as a whole, in a wider, interregional perspective? Although the current state of research hampers any definite conclusions, we may bring forward some suggestions.

The political-cultural framework of 13th-century northern Syria is poorly understood. Simply stated, it seems that, after the fall of Mitanni, western Syria, up to the Euphrates, is controlled by the Hittites, that the eastern-most part of Syria falls within the Assyrian realm, whereas the intermediate region, perhaps including the Balikh valley, is part of the kingdom of Hanigalbat. Assyrian texts clearly demonstrate that the kings of Assyria considered Hanigalbat as being part of their sphere of influence, thereby taking the Euphrates, and the Hittite stronghold of Carchemish, as the western border. It is doubtful whether Assyrian power in this region was firmly established; particularly during the first half of the 13th century it seems to be of a fluctuating and superficial nature, based upon weak vassal contracts with local elites and requiring constant military intervention and repression (see e.g. Wilhelm 1982:55ff). Direct textual references to the Balikh area are not known yet, but Harranu (modern Harran and situated about 60 km north of Sabi Abyad) is repeatedly mentioned, as well as the city of Nahur near Harran (Grayson 1972:58ff). Adad-narari I (ca. 1305-1274 B.C.) claims to have forced Shattuara, king of Hanigalbat, to become his vassal and to pay him a yearly tribute. Soon afterwards, however, Shattuara's son and heir to the throne, Uasashatta, revolted against the Assyrian king, although with little success. Adad-narari defeats Uasashatta and mentions, among others, the conquest of the city of Harran and its surroundings up to the bank of the Euphrates. Adad-narari pursued Uasashatta up to the city of Irridu, which has to be sought for in the region west or south of Harran, perhaps near Arslan Tash (Kessler 1980:65). It seems evident that at this time the Balikh valley, too, must have felt the Assyrian force, either directly (appearance of Assyrian troops) or indirectly (changing relations of power). It seems, however, that victory was not granted Adad-narari for long. Adad-narari's son, Shalmaneser I (1273-1244), was already forced in the first year of his reign to take up war against Hanigalbat. In literally the same words as his father, Shalmaneser then states to have reinstated Assyrian supremacy as far as the Euphrates, up to Carchemish (Grayson 1972:82-83). The strength of Assyrian power in this region, however, is enigmatic. Klengel (1970) suggests that throughout the 13th century an area east of the Euphrates was under Hittite influence. Shalmaneser's victory in Syria seems, however, to have decided the continuous struggle between the Hittites

and Assyrians for control of northern Syria in favor of Assyria (Munn-Rankin 1975:281) and may have led to more clearly demarcated boundaries of both the Assyrian and Hittite spheres of influence. Whether conditions were truly stable remains doubtful. Shalmaneser's successor, Tukulti-ninurta I, was forced, in the year of his accession to the throne, to wage war in Syria again. Significantly enough, however, he crossed the Euphrates in doing so and deported thousands of "Hittites" to Assur (Grayson 1972:118). Generally stated, Hittite political influence east of the Euphrates seems to have been limited, particularly in the second half of the 13th century (see Harrak 1987 for an extensive discussion on the Assyrian expansion in Syria).

Shalmaneser's war in Syria seems to have led to the annexation of Hanigalbat and Assyrian governors were appointed in several of Hanigalbat's cities. Although it seems that the Khabur region was the main area of Assyrian political expansion, the areas further west were definitely affected. At Tell Fakhariyah some legal documents were found, undoubtedly Assyrian, although there are no clues as to function or position of the persons mentioned. Further west, Harran and Tell Fray on the Euphrates seem to give evidence of a Middle Assyrian government seat (Matthiae 1980; Harrak 1987:195, 204). At this time, the Balikh valley, too, may have been more closely attached to the Assyrian empire. The changing Assyrian policy towards the outer regions has recently been discussed by Machinist (1982) who points out that during the 13th century "we can trace the shift of emphasis away from periodic raids now to more durable solutions: first, to reducing an area to vassalage, with loyalty oaths, regular tribute, and often corvee service imposed upon the local ruler and his people; then, to converting the area to a province under direct Assyrian supervision" (ibid.:78). Consolidation of Assyrian power in the outer provinces seems to have taken place under the reigns of Shalmaneser I and Tukulti-ninurta I, and it is exactly within this period that we find the most striking parallels (particularly regarding the ceramics) for Sabi Abyad, viz. at Tell Sheikh Hamad, the ancient Dur-katlimmu, on the Khabur.

The establishment of direct Assyrian control in the provinces involved considerable rearrangements of administration (Machinist 1982:82 ff; but see also Postgate 1983-84). Within the various regions, Assyrian power centred on an administrative capital or governor's seat, surrounded by *alanu* or towns of minor importance, villages and manors with their associated fields. The territorial range of these administrative units is vague, but when taking the lower Khabur as an example, it seems that the distance between governor's seats is extremely limited, viz. varying between 27 and 40 km (Pfälzner 1986). Apparently, the consolidation of Assyrian power involved the implantation of closely spaced

administrative centres, each of them being responsible for the maintenance of order, the organisation, storage and control of agricultural production, and the regular supply of taxes. Associated with the establishment of political-economic centres are large-scale movements, and deportations, of people, aimed at breaking local resistance and supplying the Assyrian heartland with labour forces (Machinist 1982:82). At the same time, the presence of native Assyrians, in the status of government officials, merchants or soldiers became more prominent in the provinces. Machinist (1982:83) suggests that these Assyrians not only came to rule but also to settle, thereby founding communities which were largely self-supporting and hardly integrated with the local population (see also Harrak 1987:203, who points out that during Shalmaneser's reign Hanigalbat witnessed "a series of administrative centers, purely Assyrian, implanted in the occupied land like islands in a sea of native Hurrians").

When we now return to the Balikh valley, it is not unlikely that the changing pattern of settlement in this region after the Hammam VIII A period is, at least partially, due to Assyrian policies. It may very well be that LBA settlement at Sabi Abyad was closely affiliated with the Assyrian governance system. Obviously, in the absence of direct textual evidence, we can neither prove nor deny the presence of Assyrians at Sabi Abyad (see, however, the contribution by Jas, this volume). The material assemblage itself gives no conclusive information in this direction at present. Although the pottery of Sabi Abyad is virtually identical to that found at Sheikh Hamad on the Khabur, identified by texts as the Assyrian governor's seat of Dur-katlimmu (Röllig 1978; Kühne 1978:16), we avoid any direct "pots and people" associations. Here we may point to the close relationship between Hammam VIII A and VIII B/Sabi Abyad pottery, the latter perhaps a local outgrowth of earlier phase VIII A developments (Smit 1988). Pfälzner (1986:168), on the contrary, suggests that the so-called Middle Assyrian pottery of Dur-katlimmu and related sites in the Khabur region is the result of Assyrian state-directed production. Moreover, he states (1986:173) that these ceramics are only found at Assyrian administrative centres, clearly to be distinguished from local, non-Assyrian communities. Although the manufacturing of ceramics at this time may be centrally organised, it is questionable whether this production is a prerogative of the Assyrian government only, and whether the pottery cannot be used by local populations, too. In the Balikh valley we find this "Middle Assyrian" pottery not only at economic-administrative centres like Sabi Abyad but also at extremely small sites like Khirbet esh-Shenef, representing single farms instead of administrative units.

The widespread distribution of Sabi Abyad-like ceramics, however, points towards the existence of a close network of communication between various

regions at this time. We find this pottery not only along the Khabur, e.g. at Sheikh Hamad, but even as far as Tell Mohammad 'Arab and Tell Billa in the east. It thus seems that the Balikh valley was not an isolated region outside the mainstream of cultural development, but, on the contrary, played an active role within this cultural framework. The concentration of settlement in the upper part of the Balikh valley suggests a close orientation towards the north, i.e. the region around Harran. Since the latter is claimed by the Assyrian kings as part of their territory, it seems reasonable to assume that in the 13th century the Balikh valley, too, was part of the Assyrian sphere of influence (thereby leaving the question aside whether Assyrians were actually present or not in the Balikh area). In this view, Sabi Abyad may represent the seat of a local ruler subordinate to the Assyrian king. To judge by the construction works at Sabi Abyad (e.g. the large building on top of the mound), the newcomers at Sabi Abyad were able to mobilise a considerable labour force. This is even more evident if we consider the fact that the settlement at Sabi Abyad, as a whole, arose within a short period of time only. Settlement at Sabi Abyad seems to be the result of deliberate planning and organisation. The desertion of sites towards the end of the 14th century suggests that direct territorial claims no longer held, and points towards changes in ownership and associated relationships of power and authority. This vacuum was filled in by settlement at Sabi Abyad and related sites. As pointed out before, Sabi Abyad is not an isolated settlement but the central part of a cluster of socially and economically related sites. A similar cluster can be found about 10 km north of Sabi Abyad, near Tell Jittal. Here we may predict the presence of a site similar to Sabi Abyad. Whether we are dealing here with a series of independent ruler's seats, or whether we are dealing with economic-administrative centres guided and protected by a "higher authority" (i.e. Assyria) remains enigmatic. At present, we are inclined towards the latter option, thereby relating the rise and fall of LBA Sabi Abyad to the establishment of Assyrian power in Hanigalbat during Shalmaneser's reign and its decline, somewhere in the 12th century B.C., after the death of Tukulti-ninurta I.

ACKNOWLEDGEMENTS

We wish to express our gratitude to the Directorate General of Antiquities and Museums of the Syrian Arab Republic for its continued assistance and encouragement; our thanks go to Dr. Ali Abu Assaf, Dr. Adnan Bounni, Mr. Murhaf al-Khalaf, Mr. Mohammad Muslim and Mr. Mohammad Maktash. We also acknowledge the support of the local administration in Raqqa (particularly Mr. Mohammad Abdul Hamid).

The excavations at Tell Sabi Abyad were directed by Peter M.M.G. Akkermans. Other members on the staff were Karin Bartl (FU, Berlin), Monica Dütting (IPP, Amsterdam), Peter Kranendonk (IPP), Marie LeMière (CNRS, Lyon), Miguel Molist (Universtitat Autònoma,

Barcelona), Mohammad Muslim (representative of the Department of Antiquities who also worked as a square supervisor), Hans Piena (IPP, Amsterdam), Inge Rossmeisl (AHI, Amsterdam), Miriam Teeuwisse (IPP, Amsterdam), Marc Verhoeven (IPP) and Maarten Wispelwey (IPP). The human skeletal remains were studied in the field by Miriam Teeuwisse, whereas Liesbeth Smits provided some highly valuable comments. Gert-Jan de Roller (BAI, Groningen) took care of the botanical remains in the field. Photographical work was done by Michiel Bootsman and Fred Gijbels. The drawings were made by Ben Claasz Coockson and Odette Haex prepared the figures. Bert Houben took care of the typesetting. We thank Diederik J.W. Meijer, director of the excavations at nearby Tell Hammam et-Turkman, for the cooperation and sharing of the facilities in the field. Last but not least, we thank Jesper Eidem (University of Copenhagen) and Claudine Vincente (Yale University) for their preliminary study of the two cuneiform tablets of Sabi Abyad.

The investigations at Tell Sabi Abyad were supported by the Foundation for Archaeological Research, which is subsidised by the Netherlands Organisation for Scientific Research (NWO). Further funding was provided by the Foundation for Anthropology and Prehistory in the Netherlands, the Albert Egges van Giffen Instituut voor Prae- en Protohistorie (IPP, Amsterdam), the Centre National de la Recherche Scientifique (CNRS, Lyon) and some private sponsors. The A.E. van Giffen Instituut voor Prae- en Protohistorie provided the facilities to prepare the present publication.

BIBLIOGRAPHY

AKKERMANS P.M.M.G.

1987a "Tell Sabi Abyad: Preliminary Report on the 1986 Excavations", *Akkadica* 52: 10-28.

1987b "A Late Neolithic and Early Halaf Village at Sabi Abyad, Northern Syria", *Paléorient* 13: 23-40.

1989 "The Other Small Finds of Tell Sabi Abyad", in: Peter M.M.G. Akkermans, Ed., *Excavations at Tell Sabi Abyad*, Oxford: BAR International Series 468, pp. 285-294.

AKKERMANS P.M.M.G., Ed.

1989 *Excavations at Tell Sabi Abyad - Prehistoric Investigations in the Balikh Valley, Northern Syria*. Oxford: BAR International Series 468.

ARCHI A.

1980 "Materiale epigrafico ittita da Tell Fray", *Studi Micenei ed Egeo-Anatolici* 22: 31.

BARTL K.

in press "Soundings at Khirbet esh-Shenef, A Late Bronze Age Settlement in the Balikh Valley, Syria", *Akkadica*.

BOEHMER R.M.

1965 *Die Entwicklung der Glyptik während der Akkad-Zeit*, Berlin.

BOESSNECK J. und VON DEN DRIESCH A.

1986 "Tierknochen- und Molluskenfunde aus Munbaqa", *Mitteilungen der Deutschen Orient-Gesellschaft* 118: 147-160.

AKKADICA 66

MALLOWAN M.E.L.

1946 "Excavations in the Balikh Valley, 1938", *Iraq* 8: 111-162.

MATTHIAE P.

1980 "Ittiti ed Assiri a Tell Fray: lo scavo di una città medio-siriana sull'Eufrate", *Studi Micenei ed Egeo-Anatolici* 22: 35-51.

MOOREY P.R.S.

1980 *Cemeteries of the 1st Millennium B.C. at Deve Hüyük*, Oxford: BAR International Series 87.

MOORTGAT A.

1941-42 "Assyrische Glyptik des 13. Jahrhunderts", *Zeitschrift für Assyriologie* 47: 50-88.

MUNN-RANKIN J.M.

1975 "Assyrian Military Power 1300-1200 B.C.", in: I.E.S. Edwards et al., Eds., *History of the Middle East and the Aegean Region c. 1380-1000 B.C.*, Cambridge: CUP, CAH 2, pp. 274-306.

PARROT A.

1961 "La glyptique de Mari à l'époque du palais", *Syria* 38:6.

PFÄLZNER P.

1986 Aspekte mittelassyrischer Keramikproduktion und Provinzverwaltung in 'Agiggebiet und am Unteren Habur, MA thesis, Frei Universität Berlin.

POSTGATE N.

1983-84 Review of P. Machinist, "Provincial Governance in Middle Assyria and Some New Texts from Yale", *Mesopotamia* 18-19: 229-233.

REUTHER O.

1926 *Die Innenstadt von Babylon*, WVDOG 47, Berlin.

ROAF M.

1983 "A Report on the Work of the British Archaeological Expedition in the Eski Mosul Dam Salvage Project from November 1982 - June 1983", *Sumer* 39: 68-94.

RÖLLIG W.

1978 "Dur-katlimmu", *Orientalia* N.S. 47: 419-430.

ROSSMEISL I.

1989 "Late Bronze Age Pottery of Tell Sabi Abyad", in: Peter M.M.G. Akkermans, Ed., *Excavations at Tell Sabi Abyad*, Oxford: BAR International Series 468, pp. 337-356.

SMIT F.

1988 "The Period VIII Pottery", in: Maurits N. van Loon, Ed., *Hammam et-Turkman*, Vol. I, Istanbul: Nederlands Historisch-Archeologisch Instituut, pp. 457-497.

SMITH S.

1949 *The Statue of Idri-mi*, London (Occasional Publications of the British Institute of Archaeology in Ankara 11).

BÖKÖNYI S.

- 1985 "Subfossil Elephant Remains from Southwestern Asia", *Paléorient* 11: 161-163.

BUCCELLATI G. and KELLY-BUCCELLATI M.

- 1977 "Terqa Preliminary Reports, No. 1: General Introduction and the Stratigraphic Record of the First Two Seasons", *Syro-Mesopotamian Studies* 1: 73-133.

DESROCHES-NOBLECOURT CHR., DONADONI S. and EDEL E.

- 1971 *Grand Temple d'Abou-Simbel, La Bataille de Kadach, description et inscriptions, dessins et photographies*, Le Caire, Pl.IV.

FRANKFORT H.

- 1939 *Cylinder Seals*, London: Macmillan.

GEERLINK J.

- 1989 "The Human Skeletal Remains of Tell Sabi Abyad", in: Peter M.M.G. Akkermans, Ed., *Excavations at Tell Sabi Abyad*, Oxford: BAR International Series 468, pp. 295-300.

GRAYSON A.K.

- 1972 *Assyrian Royal Inscriptions*, vol. 1, Wiesbaden: Otto Harrassowitz.

HALLER A.

- 1954 *Die Gräber und Gräfte von Assur*, WVDOG 65, Berlin.

HARRAK A.

- 1987 *Assyria and Hanigalbat*, Hildesheim: Georg Olms Verlag.

HROUDA B.

- 1961 "Tell Fecherije, Die Keramik", *Zeitschrift für Assyriologie* 54: 201-239.

KESSLER K.

- 1980 "Das Schicksal von Irridu unter Adad-Narari I", *Révue Assyriologique* 74: 61-66.

KLENGEL H.

- 1970 *Geschichte Syriens im 2. Jahrtausend v.u.Z.*, vol.3, Berlin: Akademie-Verlag.

KÜHNE H.

- 1978 "Vorläufiger Bericht über die erste Grabungskampagne auf dem Tall Seh Hamad am Unteren Habur", *Akkadica* 10: 16-23.

LECLANT J.

- 1985 "Fouilles et travaux en Egypte et au Soudan, 1983-1984", *Orientalia* 54: 347.
- 1986 "Fouilles et travaux en Egypte et au Soudan, 1984-1985", *Orientalia* 55: 246 and Tab. XIX (19- 20).

MACHINIST P.

- 1982 "Provincial Governance in Middle Assyria and Some New Texts from Yale", *Assur* 3: 65-101.

MACHULE D. et al.

- 1987 "Ausgrabungen in Tall Munbaqa 1985", *Mitteilungen der Deutschen Orient-Gesellschaft* 119: 73-134.

SPEISER E.

1933 "The Pottery of Tell Billa - A Preliminary Account", *Museums Journal* 23/3: 249-283.

STROMMINGER E.

1962 *Fünf Jahrtausende Mesopotamien*, München: Hirmer Verlag.

VAN LOON M.

1985 "Hammam et-Turkman on the Balikh: First Results of the University of Amsterdam's 1984 Excavation", *Akkadica* 44: 21-40.

WILHELM G.

1982 *Grundzüge der Geschichte und Kultur der Hurriter*, Darmstadt: Wissenschaftliche Buchgesellschaft.

WRESZINSKY W.

1935 *Atlas zur altaegyptischen Kulturgeschichte*, vol. 2, Pls. 92-99 and 168.

ZEUNER F.E.

1963 *A History of Domesticated Animals*, New York: Harper and Row.

CATALOGUE OF POTTERY AND SMALL FINDS

Fig. 7

1. SAB 88-P28. Plant and lime temper. Exterior cream, interior orange colour. Diameter 105 mm. Height 45 mm.
2. SAB 88-32. Plant and lime temper. Greenish colour. Diameter 82 mm. Height 30 mm.
3. SAB 88-P31. Plant and lime temper. Greenish colour. Diameter 140 mm. Height 43 mm.
4. SAB 88-P90. Plant, lime and fine sand temper. Cream colour. Diameter 140 mm. Height 52 mm.
5. SAB 88-P33. Plant and lime temper. Greenish colour (slightly warped). Diameter 195 mm. Height 62 mm.
6. SAB 88-P53. Plant and lime temper. Cream exterior, orange interior colour. Diameter 225 mm. Height 64 mm.
7. SAB 88-P92. Plant and lime temper. Cream colour. Diameter 210 mm. Height 72 mm.
8. SAB 88-P91. Plant and lime temper. Cream colour. Diameter 210 mm. Height 56 mm.
9. SAB 88-P54. Plant and lime temper. Cream colour. Dark, orange core. Diameter 240 mm. Height 75 mm.
10. SAB 88-P55. Plant, lime and fine sand temper. Greenish colour (warped). Diameter 140 mm. Height 50 mm.

Fig. 8

11. SAB 88-P93. Plant and lime temper. Cream colour. Dark, orange core. Diameter 150 mm. Height 360 mm.
12. SAB 88-P21. Plant and fine sand temper. Orange colour. Diameter 155 mm. Height 610 mm.
13. SAB 88-P20. Plant and fine sand temper. Orange colour. Diameter 265 mm. Height 219 mm.

AKKADICA 66

14. SAB 88-P37. Plant, lime and fine sand temper. Cream colour. Diameter 400 mm. Height 420 mm.
15. SAB 88-P35. Plant, fine sand and lime temper. Orange colour. Diameter 140 mm.
16. SAB 88-P36. Plant, fine sand and lime temper. Orange colour. Diameter base 100 mm.

Fig. 9

17. SAB 88-P78. Plant and lime temper. Cream colour. Dark, orange core. Diameter 150 mm. Height 365 mm.
18. SAB 88-P72. Plant and lime temper. Orange-cream colour. Diameter 90 mm. Height 102 mm.
19. SAB 88-P69. Plant and lime temper. Orange colour. Diameter 80 mm. Height 80 mm.
20. SAB 88-P16. Plant and fine sand temper. Buff colour. Diameter 138 mm. Height 420 mm. Burial vessel (cremation grave).
21. SAB 88-P19. Plant and lime temper. Orange colour. Diameter 145 mm. Height 49 mm.
22. SAB 88-P15. Plant, fine sand and lime temper. Cream colour. Diameter 67 mm. Height 106 mm.
23. SAB 88-P18. Plant and lime temper. Greenish colour (warped). Diameter 87 mm. Height 36 mm.
24. SAB 88-P6. Plant and fine sand temper. Orange colour. Diameter 85 mm. Height 35 mm.
25. SAB 88-P75. Plant and lime temper. Greenish colour (warped). Diameter 88 mm. Height 42 mm.
26. SAB 88-P43. Plant, fine sand and lime temper. Cream colour. Dark, orange core. Diameter 110 mm. Height 40 mm.
27. SAB 88-P4. Plant and lime temper. Exterior cream, interior buff colour. Diameter 95 mm. Height 30 mm.
28. SAB 88-P41. Plant and lime temper. Cream colour. Diameter 90 mm. Height 35 mm.
29. SAB 88-P1. Plant and lime temper. Cream colour. Diameter 90 mm. Height 32 mm.
30. SAB 88-P17. Plant and lime temper. Cream colour. Diameter 160 mm. Height 53 mm.
31. SAB 88-P2. Plant, fine sand and lime temper. Greenish - cream colour. Diameter 150 mm. Height 56 mm.

Fig. 10

32. SAB 88-P10. Plant and fine sand temper. Orange colour. Diameter 140 mm. Height 50 mm.
33. SAB 88-P47. Plant and lime temper. Cream exterior, orange interior colour. Grey core. Diameter 150 mm. Height 60 mm.
34. SAB 88-P22. Plant, fine sand and lime temper. Buff colour. Diameter 155 mm. Height 55 mm.
35. SAB 88-P44. Plant and lime temper. Orange colour. Grey core. Diameter 130 mm. Height 38 mm.
36. SAB 88-P3. Plant, fine sand and lime temper. Cream colour. Light-brown core. Diameter 135 mm. Height 46 mm.
37. SAB 88-P42. Plant and lime temper. Cream colour. Diameter 130 mm. Height 54 mm.
38. SAB 88-P7. Plant and fine sand temper. Cream colour. Orange core. Diameter 140 mm. Height 52 mm.
39. SAB 88-P45. Plant and lime temper. Greenish colour. Diameter 210 mm. Height 78 mm.

40. SAB 88-P52. Plant, fine sand and lime temper. Buff colour. Diameter 215 mm. Height 56 mm.
41. SAB 88-P79. Plant and lime temper. Orange colour. Grey core. Diameter 100 mm. Height 58 mm.
42. SAB 88-P46. Plant and lime temper. Orange colour. Diameter 342 mm. Height 131 mm.

Fig. 11

43. SAB 88-P5. Plant and lime temper. Orange colour. Diameter 90 mm. Height 95 mm.
44. SAB 88-P9. Plant and lime temper. Green colour (warped). Diameter 85 mm. Height 85 mm.
45. SAB 88-P38. Plant and lime temper. Cream colour. Diameter 91 - 114 mm. Height 167 mm.
46. SAB 88-P40. Plant and lime temper. Orange colour. Diameter 235 - 250 mm. Height 166 mm.
47. SAB 88-P63. Plant, fine sand and lime temper. Orange colour. Diameter 210 - 235 mm. Height 175 mm.
48. SAB 88-P13. Plant and lime temper. Greenish colour. Diameter 200 mm. Height 195 mm.
49. SAB 88-P48. Plant and lime temper. Cream colour. Greenish core. Diameter 260 mm. Height 210 mm.

Fig. 14

50. SAB 88-P58. Plant and lime temper. Buff colour. Diameter 193 mm. Height 535 mm. Burial vessel (B3).
51. SAB 88-B13/B18. Beads of shell and stone. Burial B3. National Museum Raqqa.
52. SAB 88-B19/B22. Stone beads. Burial B3. National Museum Raqqa.
53. SAB 88-I31. Shell hair ornaments. Burial B3. National Museum Raqqa.
54. SAB 88-M7. Bronze anklet. Burial B3. National Museum Raqqa.

Fig. 16

55. SAB 88-B1. Shell and stone beads. Cremation burial. National Museum Raqqa.
56. SAB 88-H1. Part of human figurine. Baked clay. Height 72 mm. Width 23 mm. Thickness 15 mm. National Museum Raqqa.
57. SAB 88-M1. Bronze pin. Height 64 mm. Diameter 5 mm.
58. SAB 88-M3. Bronze needle. Height 151 mm. Diameter 7 mm. National Museum Raqqa.
59. SAB 88-Z2. Scarab. Soft white stone. Length 17 mm. Width 15 mm. Height 7 mm. National Museum Raqqa.
60. SAB 88-T1. Seal impression on cuneiform tablet T1. Height 18 mm. National Museum Raqqa.

Fig. 17

61. SAB 88-Z3. Cylinder seal. Serpentine. Length 42 mm. Diameter 14 mm. Mass burial in square R13. National Museum Raqqa.æ

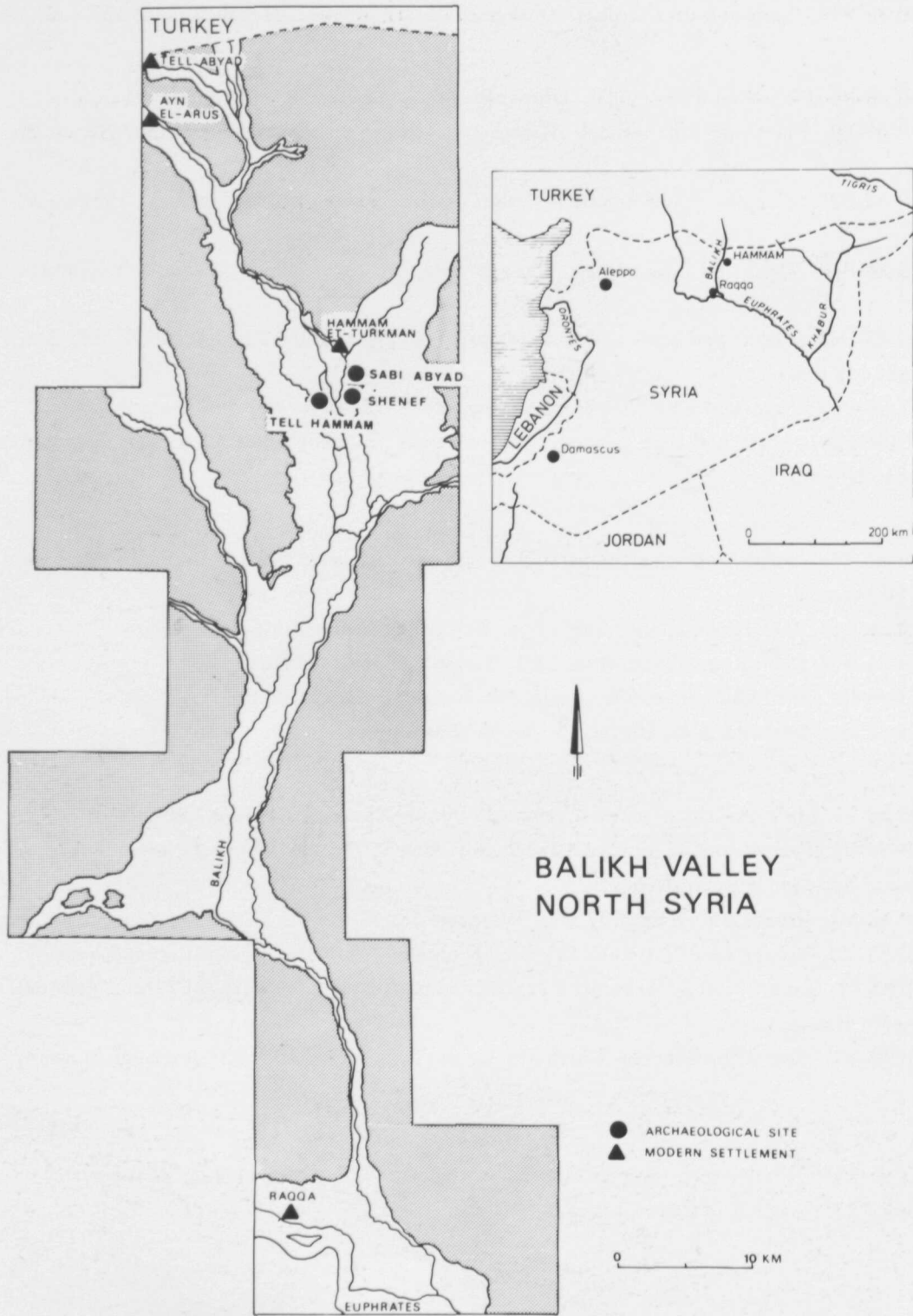

Fig. 1 Map of the Balikh valley with some of the sites mentioned in the text

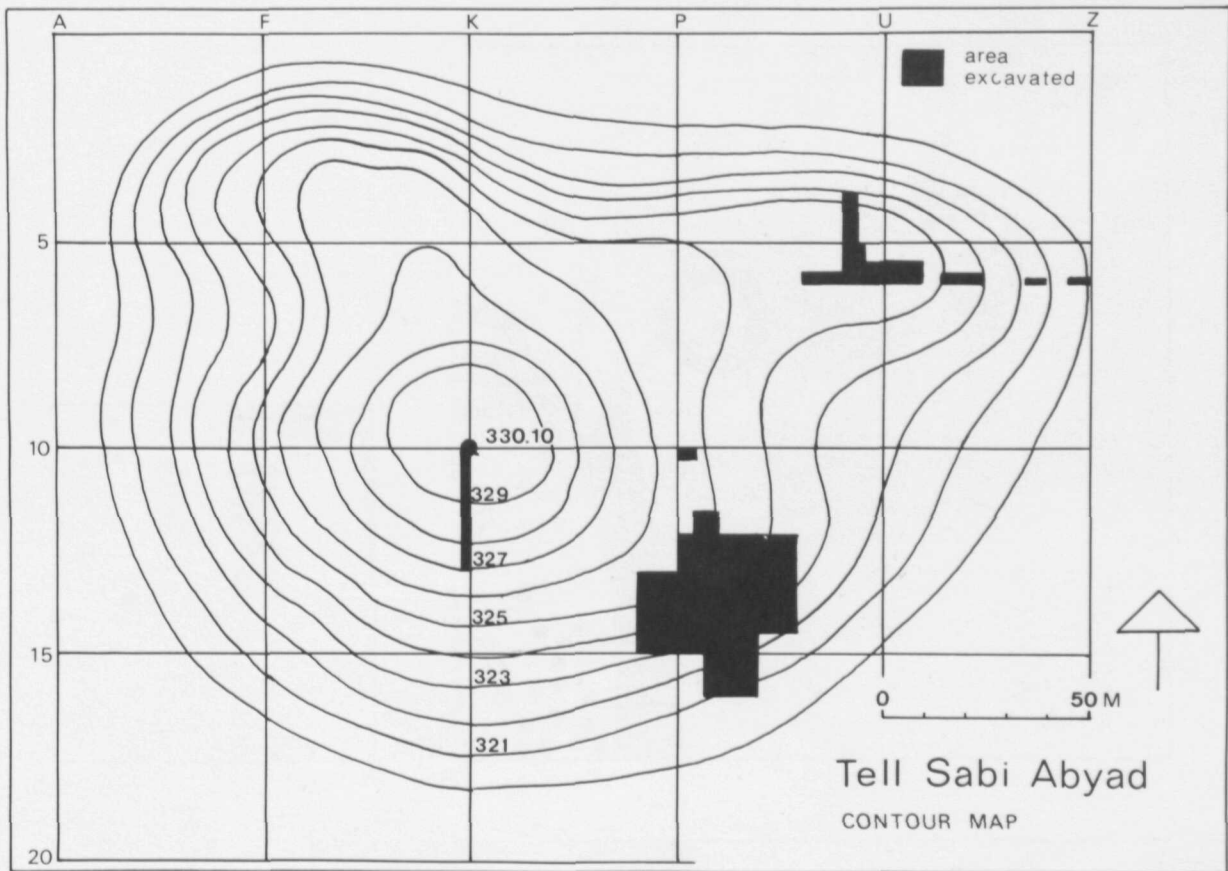

Fig.2a Plan of Tell Sabi Abyad



Fig. 2b View of Tell Sabi Abyad from the northeast

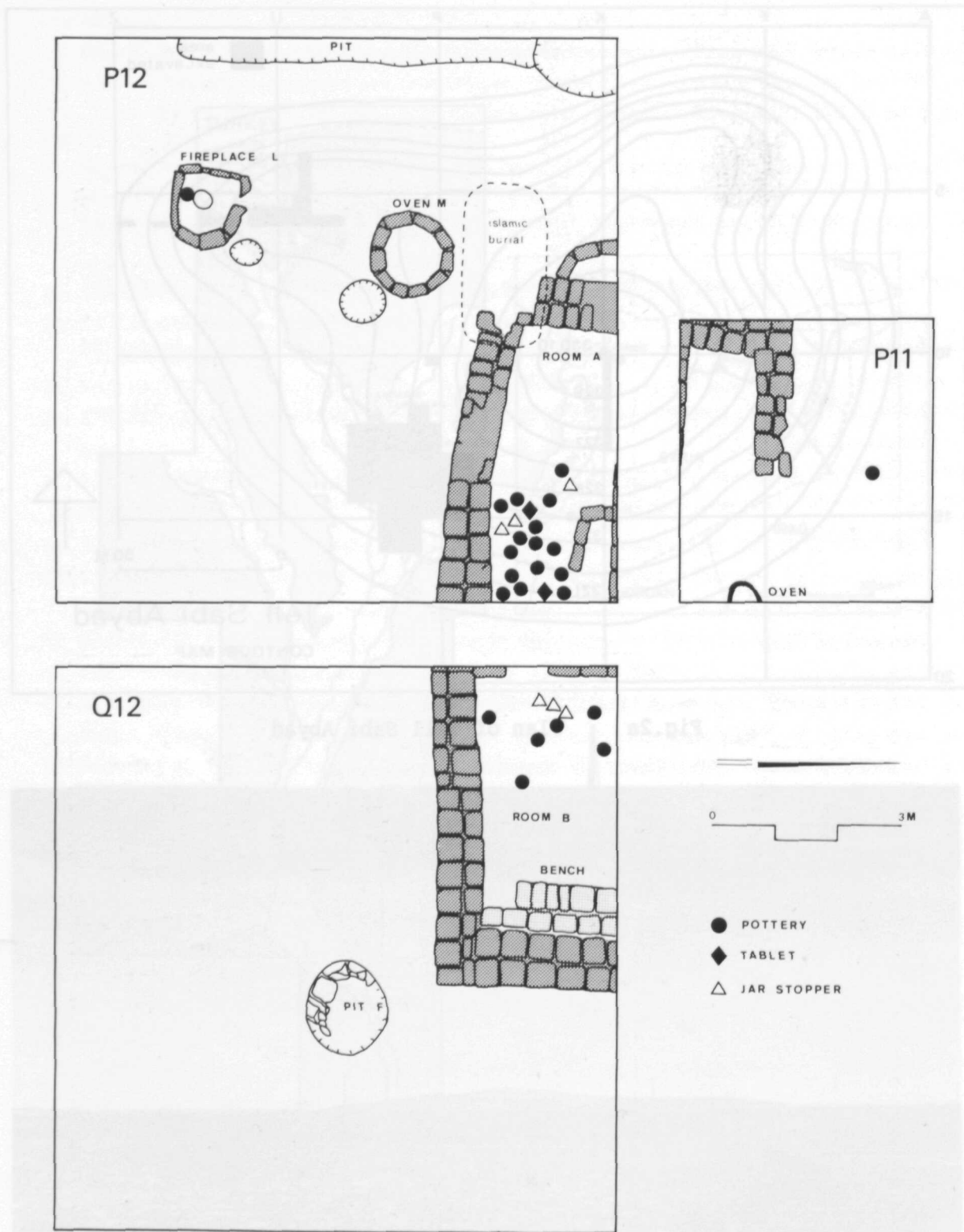

Fig. 3 Stratum 3 LBA architecture on the south-eastern mound

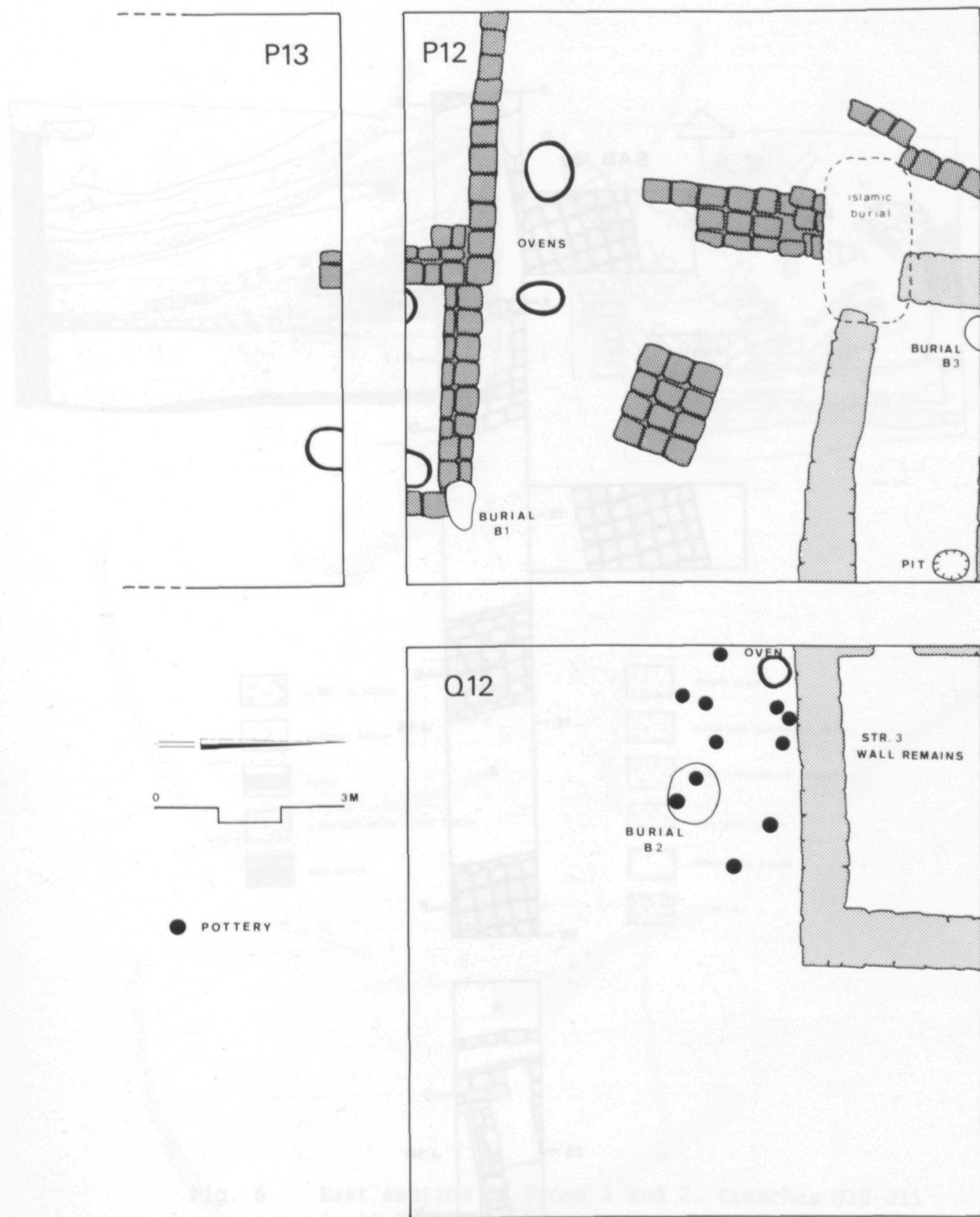
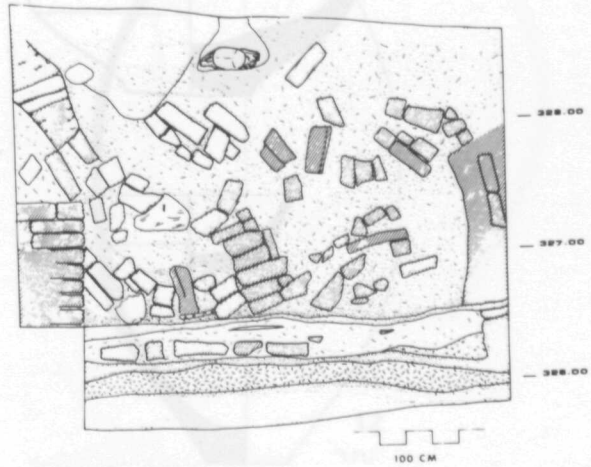
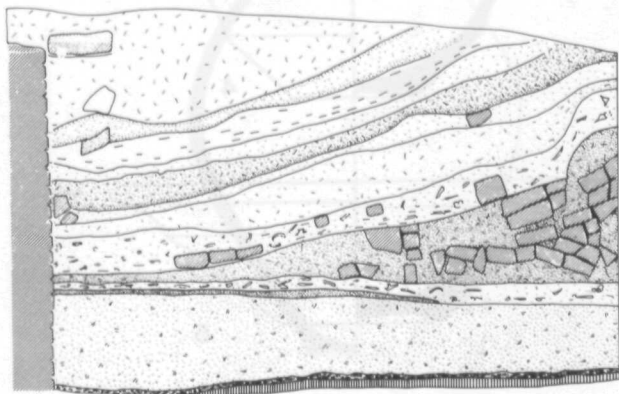







Fig. 4 Stratum 2 LBA architecture on the southeastern mound



Fig. 5 Monumental architecture on top of Sabi Abyad



-  BONE IN LAYER
-  POTTERY LAYER
-  FLOOR
-  LOAM AND WHITE-BURNT STRAW
-  MUD BRICK







-  BROWN LOAM
-  LOAM AND MUD-BRICK DEBRIS
-  BURNT MUD-BRICK DEBRIS
-  RED SOIL LAYER
-  GREY SOIL LAYER
-  CHARCOAL

Fig. 6 East section of Rooms 1 and 2, trenches J10-J11 (wall D in balk between rooms)

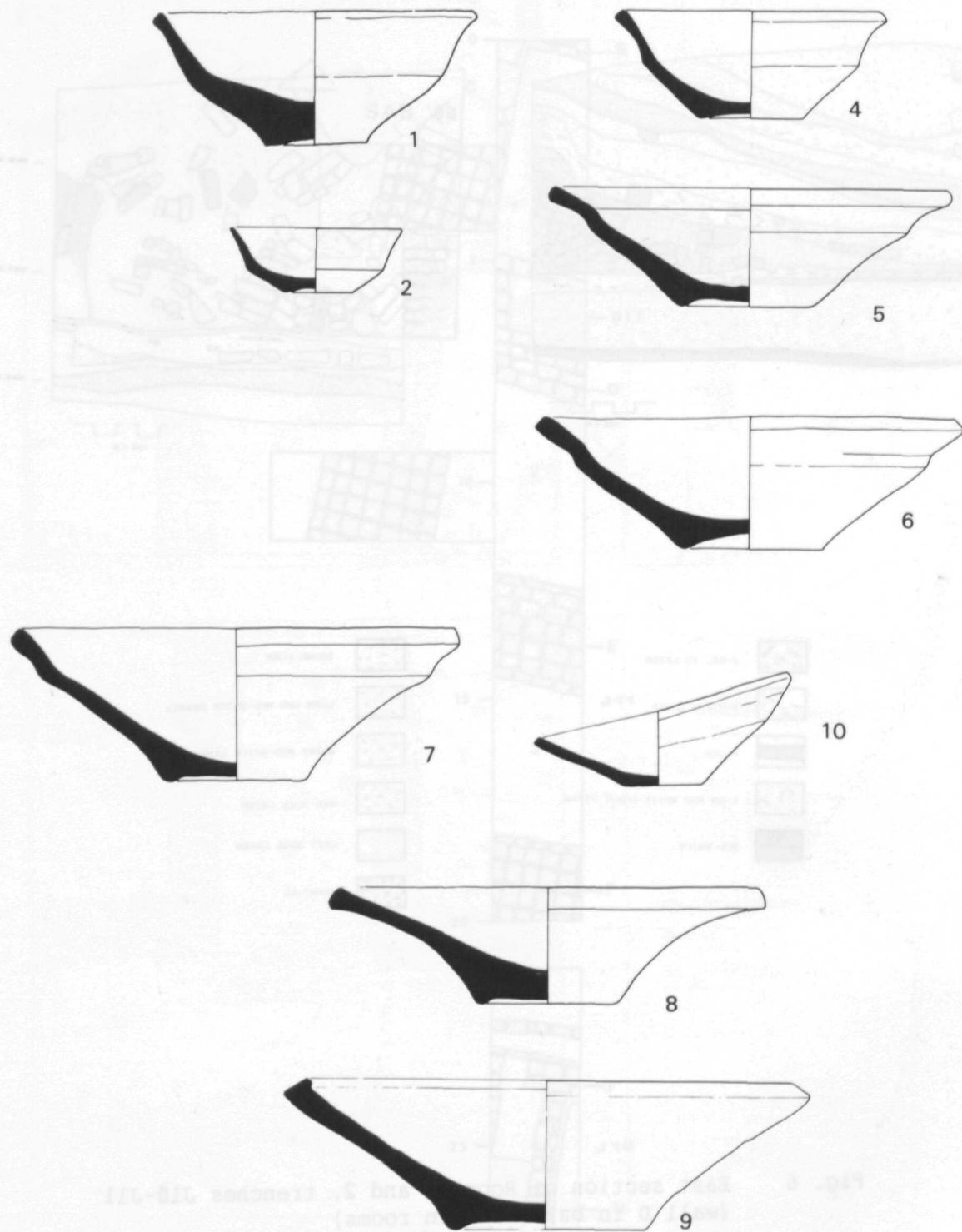

Fig. 7 Bowls found in-situ in sq. P12 and (No. 10) Q12, stratum 3 (scale 1:3)

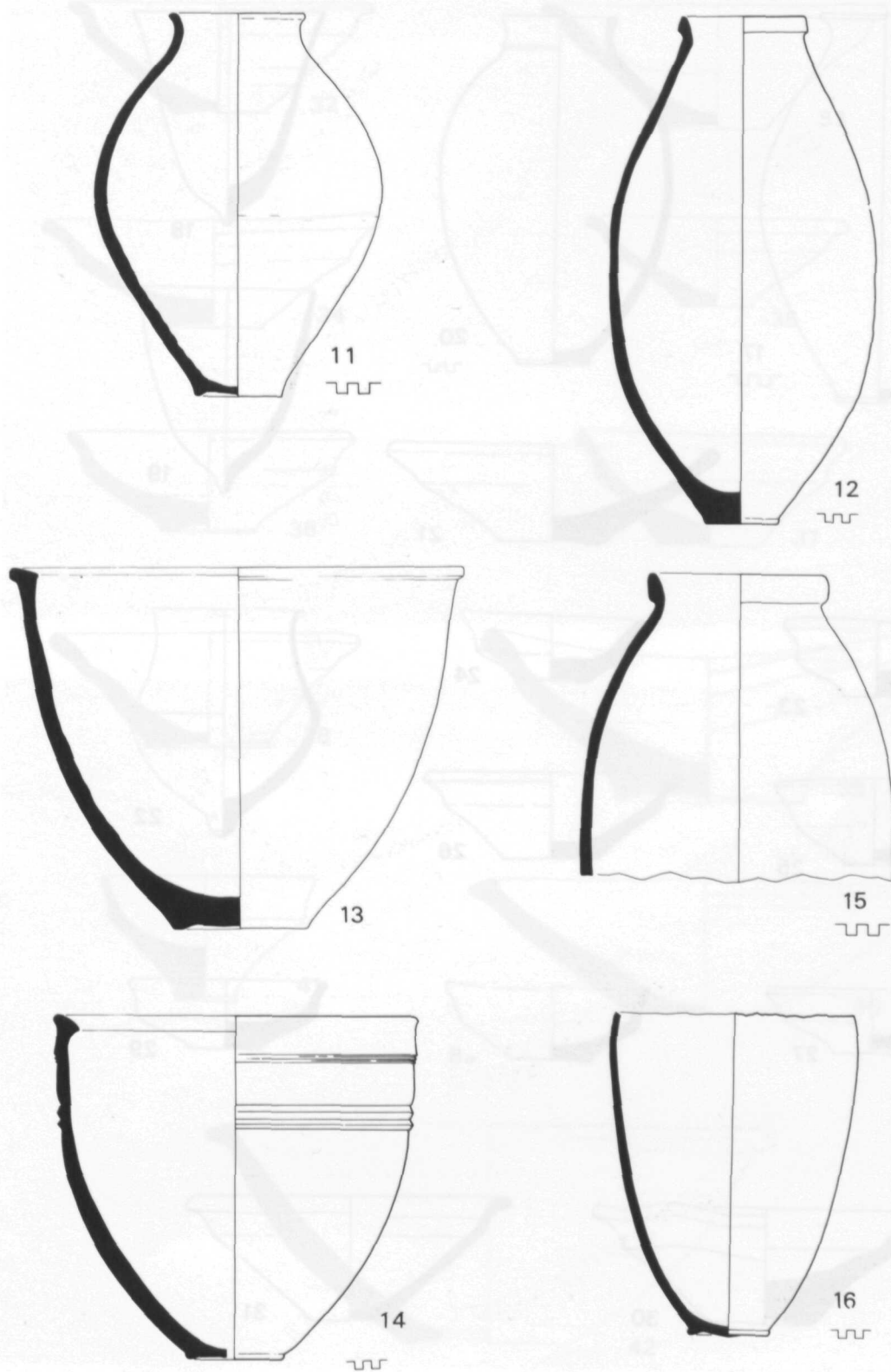

Fig. 8 Jars and pots found in-situ in sq. P12 and Q12, stratum 3
 (scale of no. 13 : 1:3, for others see measure balk)

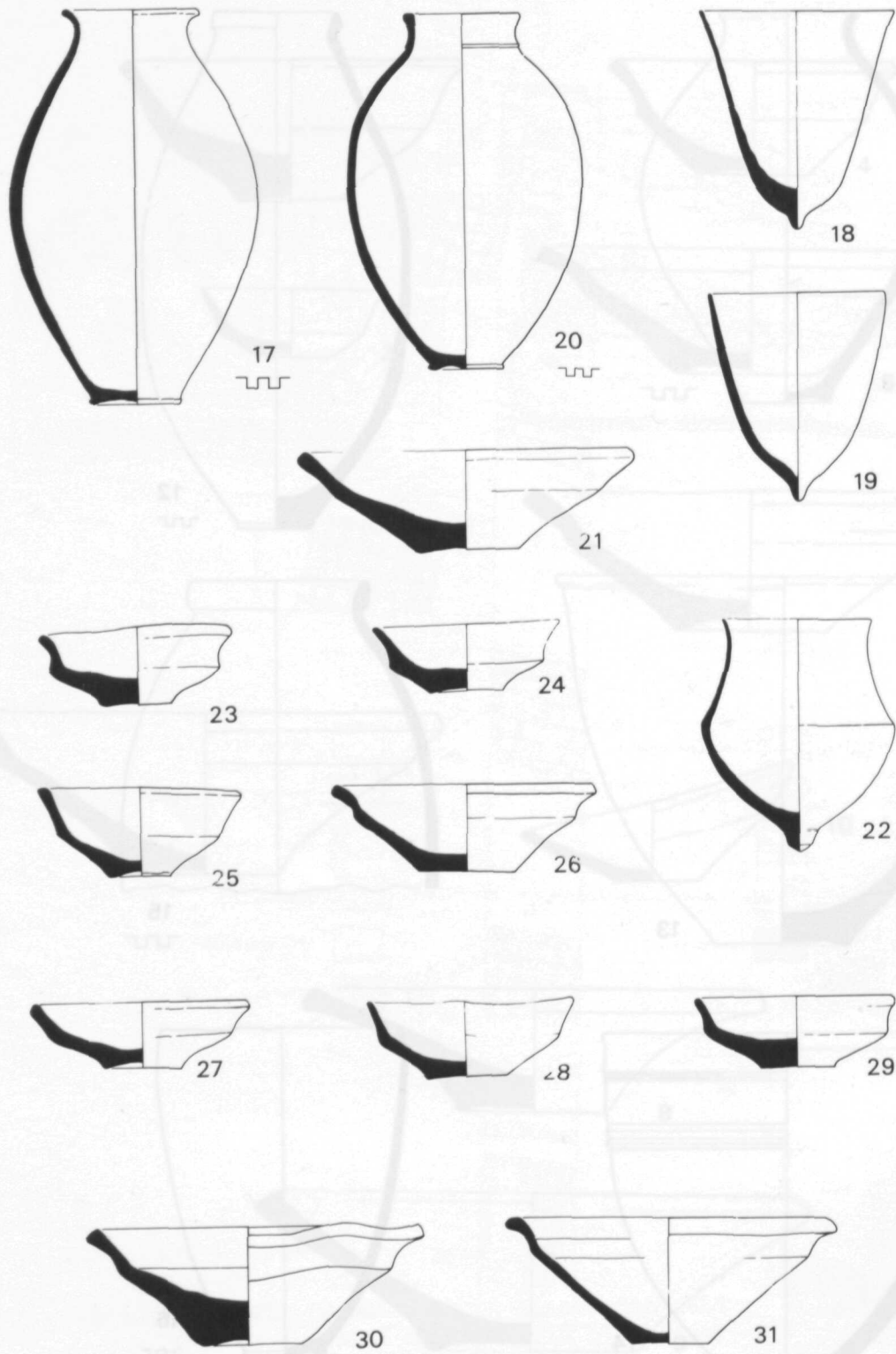

Fig. 9 LBA jars, bowls and goblets. Nos. 20-22 : cremation jar with associated bowl and goblet (scale 1:3, except nos. 17 and 20 : see measure balk)

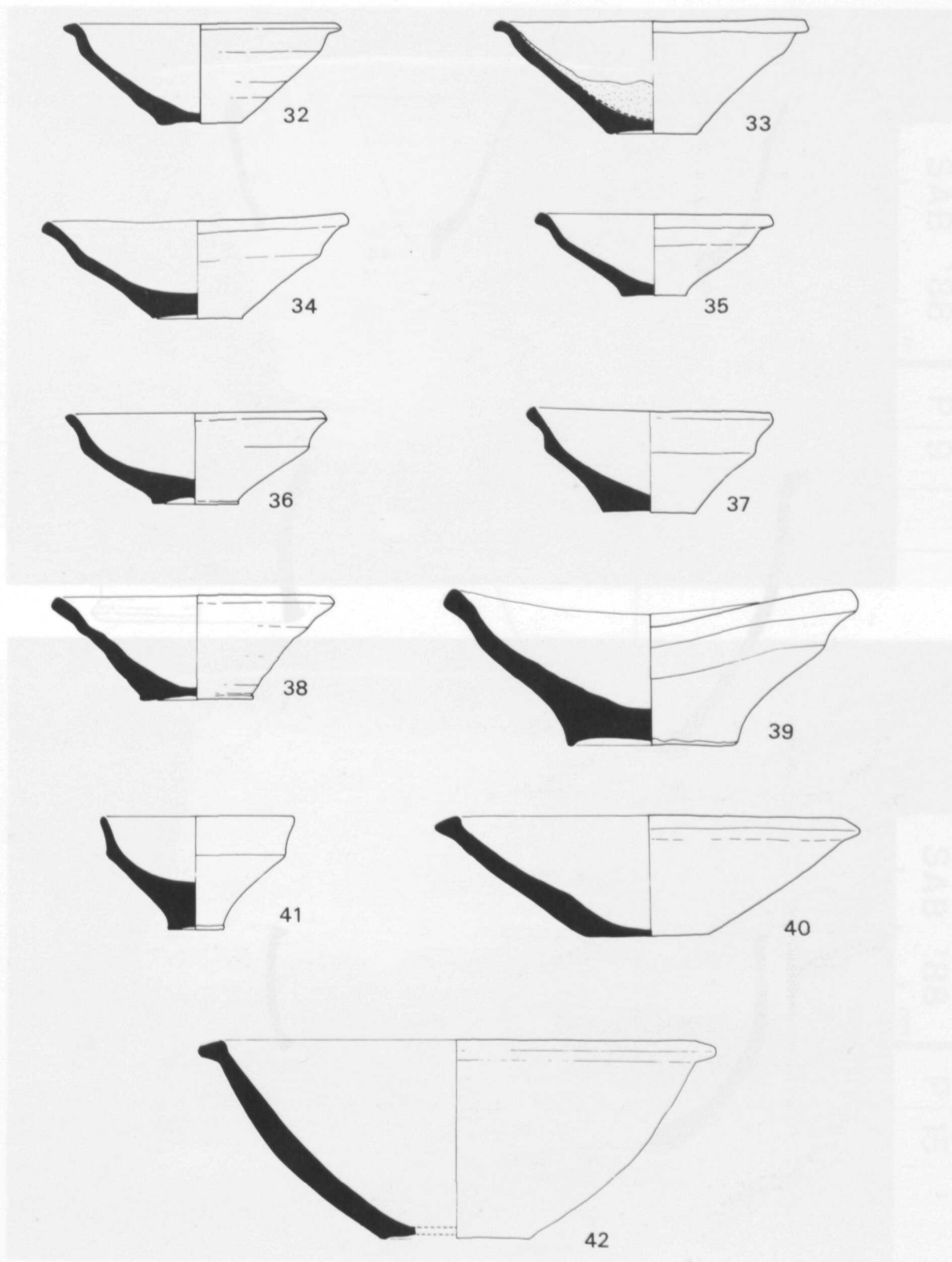

Fig. 10 LBA bowls (scale 1:3, no. 42 scale 1:4)

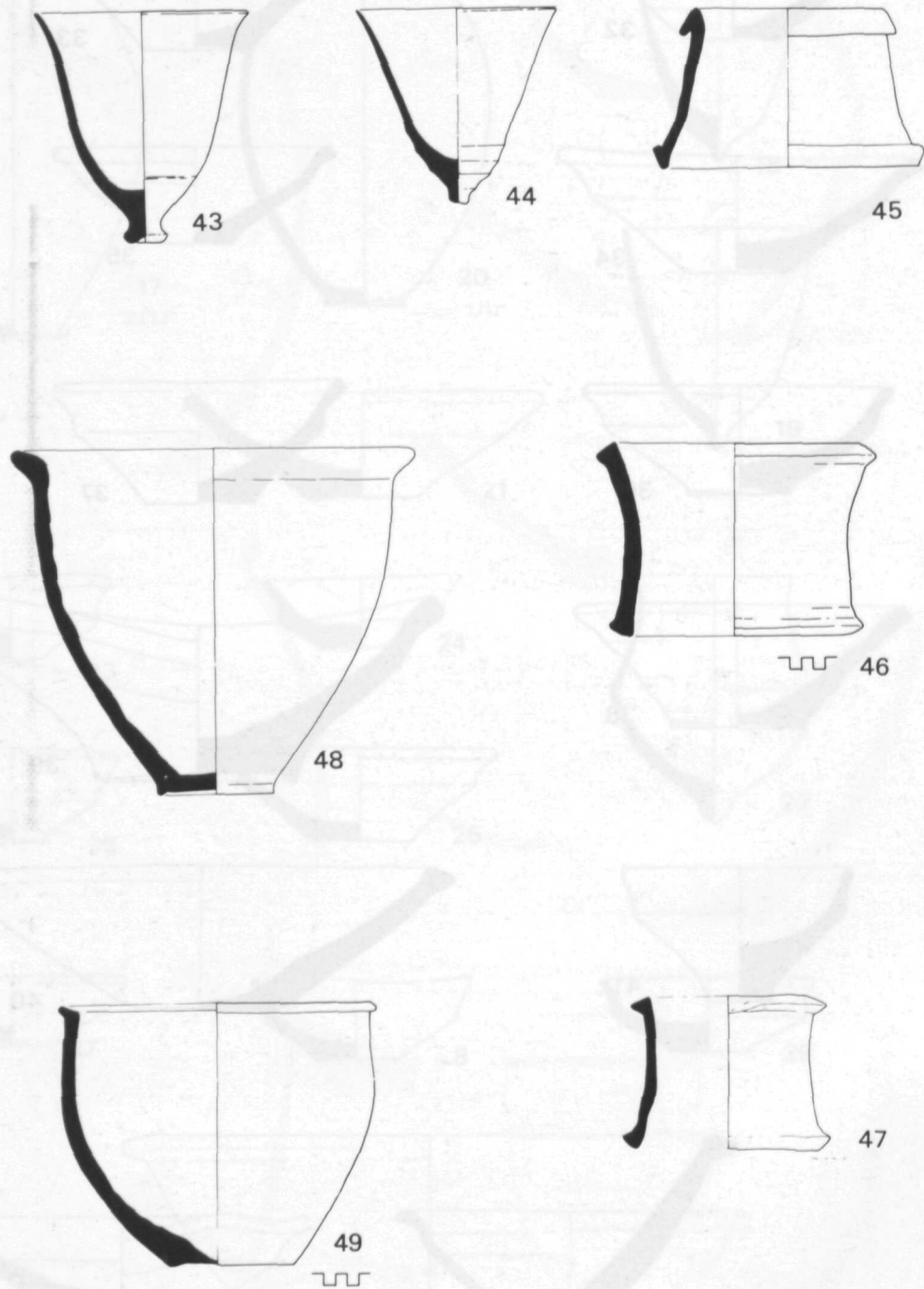

Fig. 11 LBA goblets, pots and pot stands (nos. 43-44 scale 1:3, no. 48 scale 1:4, others : see measure balk)

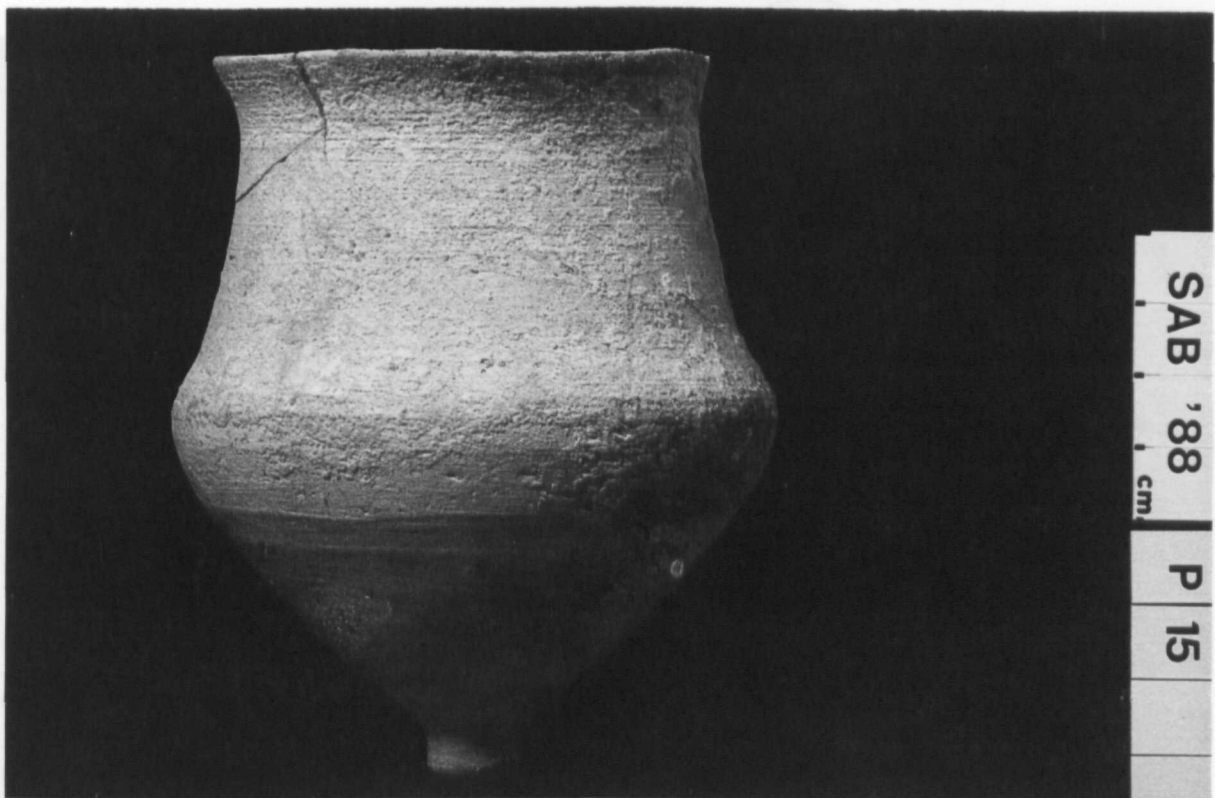
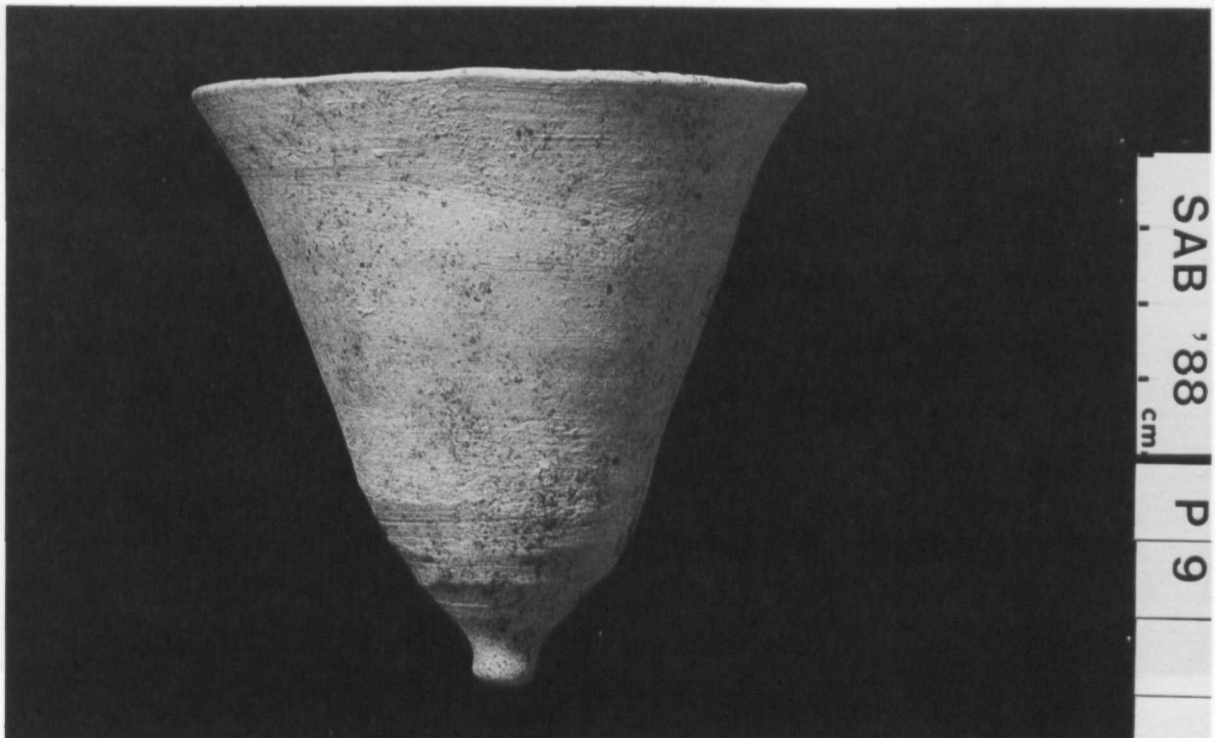
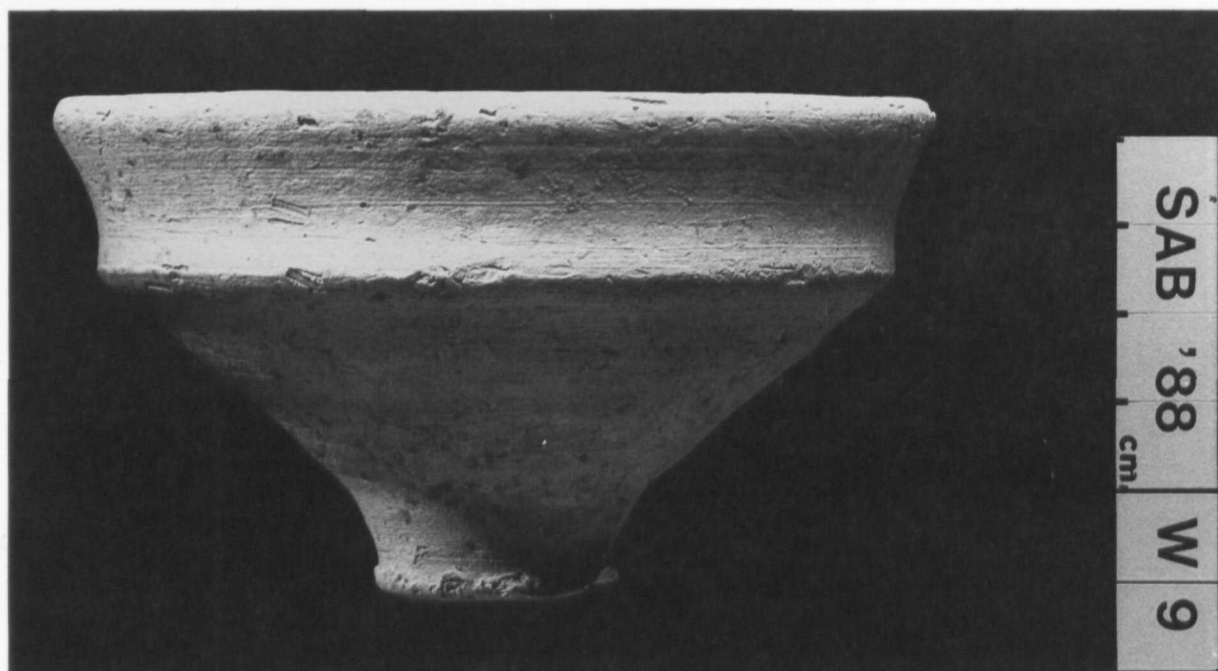

Fig. 12 LBA nipple-based goblets (cf. drawings Fig. 11, no. 44 and Fig. 9, no. 22)

Fig. 14 Burial jar and ornaments of child burial B3, sq. P12, stratum 2 (scale 1:3, except jar : see measure balk)



a



b

Fig. 13 a: LBA bowl (cf. drawing Fig. 10, no. 41)
b: LBA mass burial in sq. R13

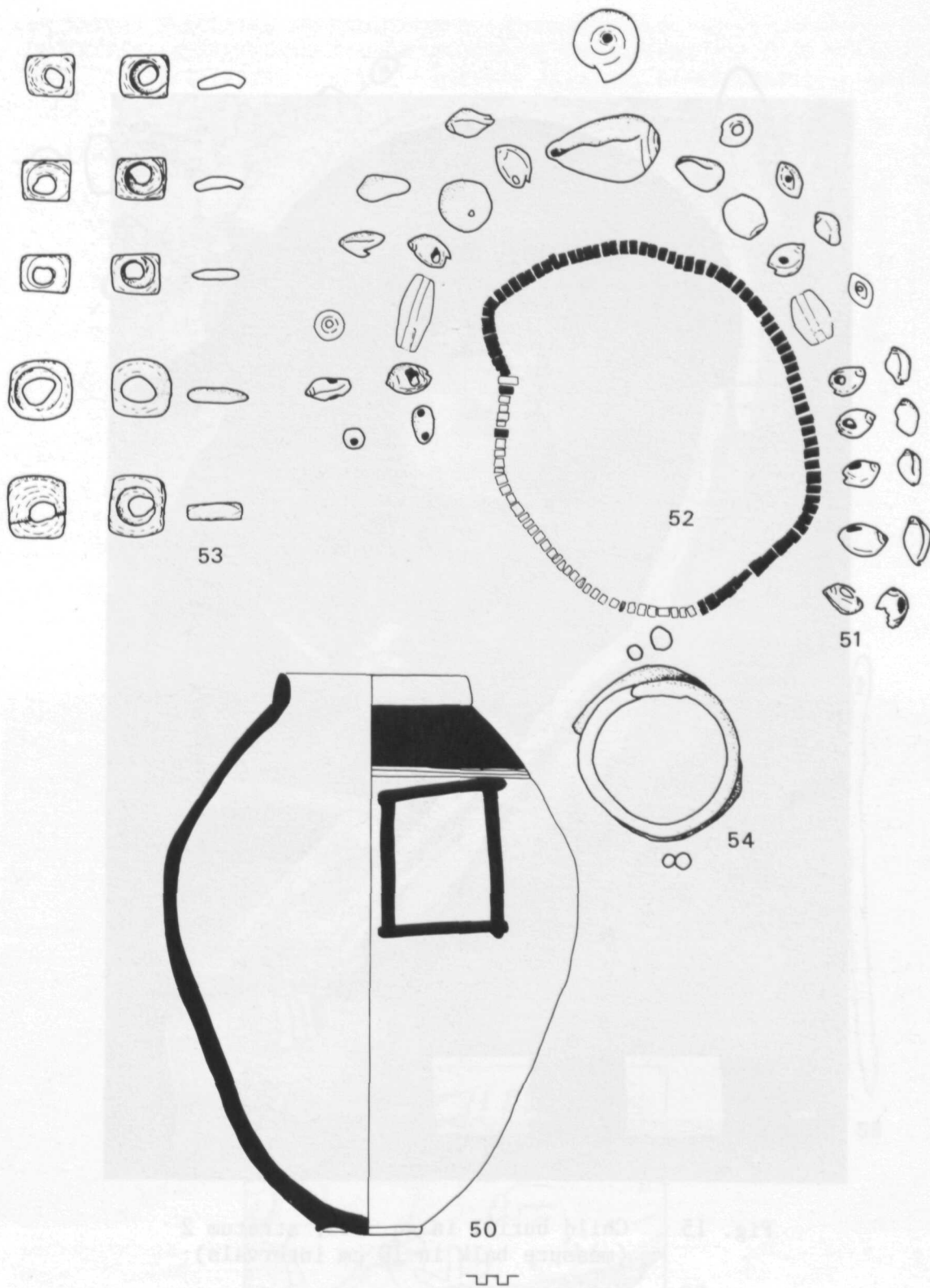
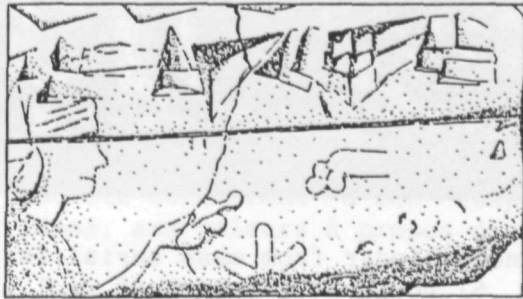
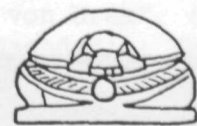
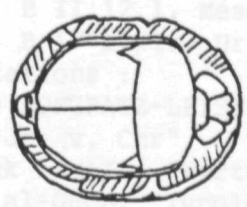
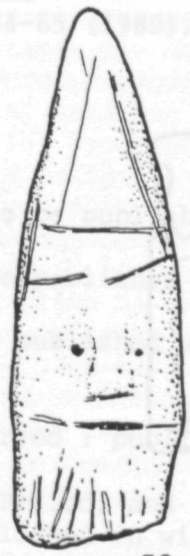
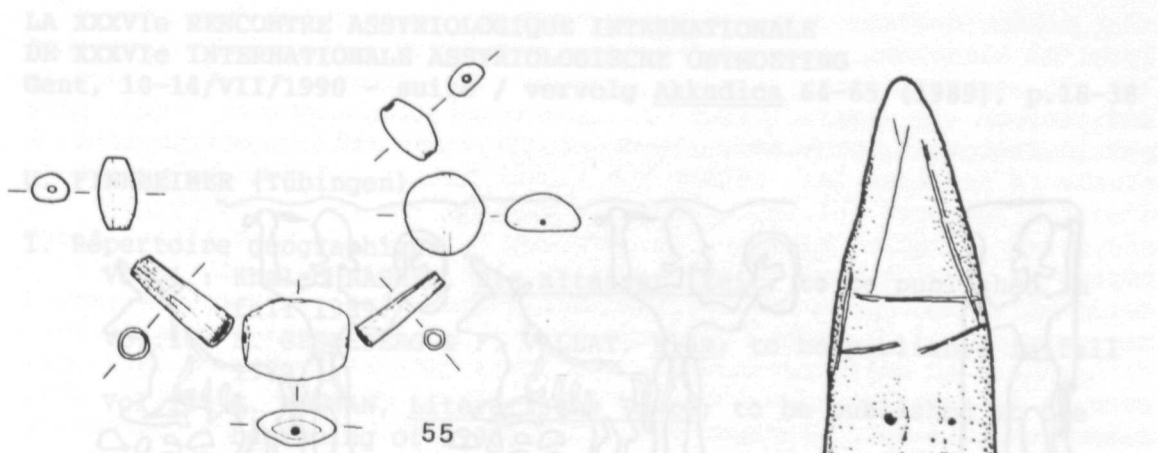

Fig. 14 Burial jar and ornaments of child burial B3, sq. P12, stratum 2 (scale 1:3, except jar : see measure balk)



Fig. 15 Child burial in sq. P12, stratum 2
(measure balk in 10 cm intervals)

Fig. 15 sq. P12, stratum 2 (cf. drawing Fig. 10, no. 41)
by LBA tomb burial (cf. drawing Fig. 10, no. 41)
Fig. 14 burial jar and ornaments of child burial 87, sq. P12
stratum 2 (scale 1:3, except jar; see measure balk)



LA XXXVI^e RENCONTRE ASSYRIOLOGIQUE INTERNATIONALE
 DE XXXVI^e INTERNATIONALE ASSYRIOLOGISCHE VEREINIGUNG
 Gent, 10-14/VII/1990 - *Journal de la Société de la Bible et de l'Archéologie* 1990, p. 18-38
 Tübingen (Tübingen)
 1. *Journal de la Société de la Bible et de l'Archéologie* 1990, p. 18-38
 Sheet 1-3 18. Iran, Chalcolithic Period, and
 Mesopotamia, Chaldean, and
 3. *Journal de la Société de la Bible et de l'Archéologie* 1990, p. 18-38
 "Götterpropheten" von Tadmor 1.
Journal de la Société de la Bible et de l'Archéologie 1990, p. 18-38
 "Survey" von Tadmor 1.

Fig. 16 LBA small finds (nos. 55, 57-58 scale 1:3, no. 56 scale 1:1, nos. 59-60 scale 2:1)



61

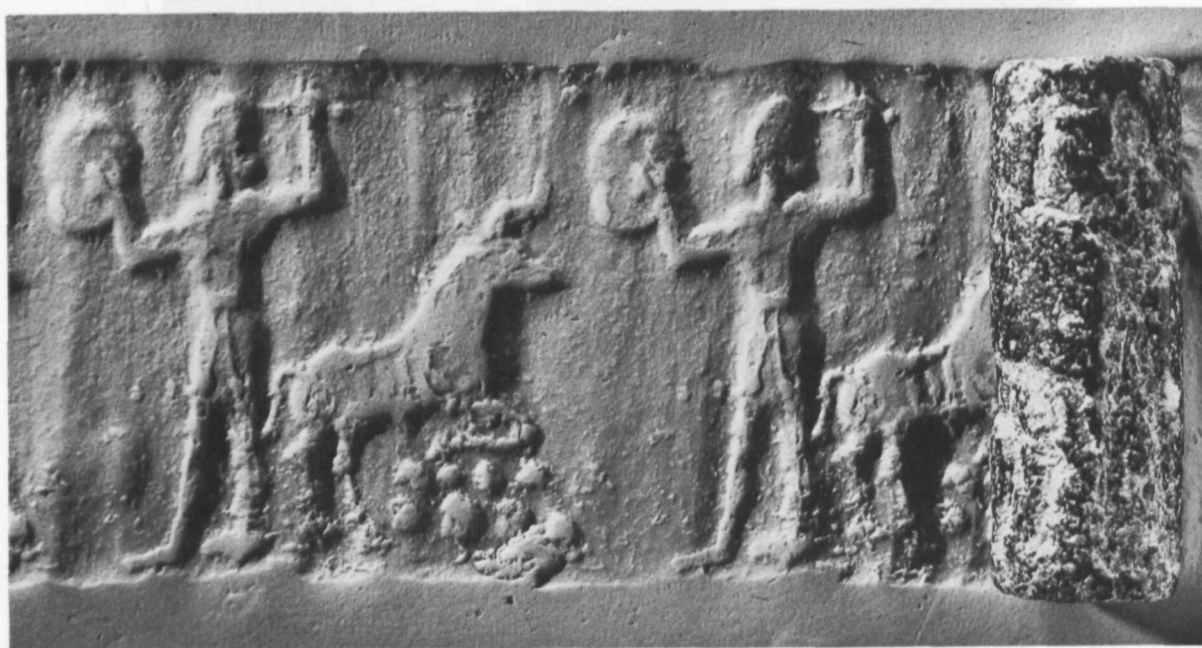

Fig. 17 Stone cylinder from mass burial in sq. R13
(no. 61 scale 1:1, length of seal 42 mm)